

TRANSIENT THERMAL PERFORMANCE PREDICTION METHOD FOR PARABOLIC TROUGH SOLAR COLLECTOR UNDER FLUCTUATING SOLAR RADIATION

Tohru Suwa, ShyeYunn Heng*

TAKASAGO Thermal/Environmental Systems Laboratory, Malaysia-Japan International Institute of Technology, Universiti Teknologi Malaysia, Kuala Lumpur

Article history

Received

14 June 2015

Received in revised form

13 December 2015

Accepted

18 January 2016

*Corresponding author
syheng4@live.utm.my

Graphical abstract

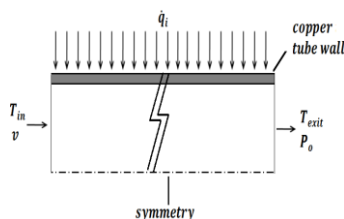

Abstract

As the effect of the global warming is becoming noticeable, the importance for environmental sustainability has been raised. Parabolic trough solar thermal collector system, which is one of the solutions to reduce the carbon dioxide emission, is a mature technology for electricity generation. Malaysia is a tropical country with long daytime, which makes suitable for solar thermal applications with parabolic trough solar thermal collectors. However, the high humidity causes the solar radiation to fluctuate. In order to simulate the solar thermal collectors' performance at an early design stage of solar thermal power generation systems, fast still accurate transient thermal performance prediction methods are required. Although multiple transient thermal simulation methodologies exist, they are not suited especially at an early design stage where quick but reasonably accurate thermal performance prediction is needed because of their long calculation time. In this paper, a transient thermal prediction method is developed to predict exit temperature of parabolic trough collectors under fluctuating solar radiation. The method is governed by simple summation operations and requires much less calculating time than the existing numerical methods. If the radiation heat loss at the parabolic trough collector tube surface is small, the working fluid temperature rise may be approximated as proportional to the receiving heat flux. The fluctuating solar radiation is considered as a series of heat flux pulses applied for a short period of time. The time dependent solar collector exit temperature is approximated by superimposing the exit temperature rise caused by each heat flux pulse. To demonstrate the capabilities of the proposed methodology, the solar collector exit temperature for one-day operation is predicted. The predicted solar collector exit temperature captures the trend of a finite element analysis result well. Still, the largest temperature difference is 38.8K and accuracy is not satisfactory. Currently, the accuracy of the proposed method is being improved. At the same time, its capabilities are being expanded.

Keywords: Concentrating solar power, solar parabolic trough collector, solar radiation fluctuation, thermal performance prediction, transient thermal analysis

© 2016 Penerbit UTM Press. All rights reserved

1.0 INTRODUCTION

The conventional power generation using fossil fuels has led to severe environmental problems as the human activities largely depend on electricity. More than 90% of electricity is generated using fossil fuel in Malaysia[1]. The electricity consumption of Malaysia

for air-conditioning shows a steady increase from 7,204 GWh in 1990 to 34,745 GWh in 2008. With the growing population, continuous increase of electricity consumption for air-conditioning is inevitable [2]. Renewable energy is one of the solutions for this fossil-fuel dependent energy situation. Concentrated solar power (CSP) technology is one of the renewable technologies to generate electricity[3, 4]. CSP has

been evolved over the past decades. Solar parabolic trough is one of the most promising CSP technologies. In the countries, such as US, Spain, Algeria, Italy, Egypt, United Arab Emirates and Thailand, solar parabolic trough power generation systems has been implemented. In addition, the solar parabolic trough power generation plants will be completed by 2015 in Mexico, India, Morocco, Chile, South Africa[3].

Parabolic trough collector tube which also called as receiver tube, absorbs heat energy by collecting the solar radiation to heat up the heat transfer fluid inside the collector tube. The heat energy accumulated by the heat transfer fluid is used to generate electricity [5]. The parabolic trough collector tube is the key component in solar parabolic trough systems[6]. Cheng et al. [7] developed steady state thermal model for parabolic trough collector. Lu et al. [8] established a heat transfer model for a parabolic trough collector with non-uniform radiation heat flux on collector's circumference. He et al. [9], Wirz et al. [10], and Hachicha et al. [11] employed optical model and finite volumemethod to analyze the heat transfer in a parabolic trough solar collector. Wang et al. [12] combined solar ray trace method and finite element method (FEM) to study the effect of a key operating parameter on a parabolic trough collector. Padilla et al. [5] implemented detailed radiation heat transfer analysis in the parabolic trough collector heat transfer model. In addition, Engineering Equation Solver was applied to analyze the steady state performance of a parabolic trough collector[13, 14]. Also, a mathematical model was developed to analyze the steady state heat transfer of a parabolic trough collector [15]. All of these studies analyze the performance of parabolic trough collector in the steady state conditions.

In Malaysia, the solar radiation fluctuates so much that the trend cannot be captured with 10-minute interval measurement. The solar radiation changes faster than thermal response time of the parabolic trough collector. Understanding the transient thermal behavior of the solar collector tubes is important to Malaysia as well as the areas where high solar radiation fluctuation is observed. Any changes in solar radiation will directly affect the working fluid temperature and impact on the entire performance of solar thermal systems. However, the transient thermal behavior for parabolic trough collector tubes has not been well known yet. Zaversky et al. [4] and Hirsch et al. [16] developed a Modelica-based transient parabolic trough collector model. The one-dimensional fluid flow was discretized into finite control volume and steady state temperature profile is applied in the control volume to analyze the transient thermal performance. The number of control volumes determines the calculation accuracy. Computational time increases proportionally to the

number of control volume. About one-week of calculation time is required to simulate one year parabolic trough collector operation by using 48 control volumes. Although there are several numerical simulation methods that are available for transient thermal analysis, it is not practical to perform numerical simulation using these existing methodologies because of their long computational time.

In this work, a method to predict the exit fluid temperature of a parabolic trough collector under fluctuating radiation is developed. The predicted temperature is compared with a finite element analysis result. The prediction method will be used for solar co-generation system shows in Figure 1. Solar parabolic trough collector concentrates the incoming solar radiation to heat the fluid flowing in the collector tube. The heated fluid is used to rotate the turbine and generate electricity by creating steam at a heat exchanger. The thermal storage in the system saves the excess thermal energy to generate electricity when the solar radiation is not available. The excessive heat from the steam turbine is used as the heat source for the adsorption refrigerator. At an early design stage of the solar co-generation systems, the system design will be optimized. In this optimization stage, the system performance will be predicted multiple times with different design variables. Different from the conventional fossil-fueled power generation systems, heat source power continuously changes: yearly, seasonally, daily, hourly, and minute wise with considerable fluctuation. As a result, the daily output of the co-generation system must be analyzed for one year or more when the performance of a design is evaluated. Large computational time would be required, when a conventional transient thermal analysis method is used for such analysis. The transient thermal performance prediction methodology developed in this research enables to evaluate solar parabolic trough transient thermal performance with much reduced calculation time and reasonable accuracy.

2.0 COLLECTOR TUBE EXIT TEMPERATURE PREDICTION METHODOLOGY

The collector tube is located at the focal line of the parabolic trough mirror. The solar radiation reached to the parabolic trough mirror is concentrated at the collector tube surface. The collected solar thermal energy is conducted to the working fluid inside the collector tube. The parabolic trough collector consists of an inner metal tube and an outer glass tube. The layer between the metal and glass tubes is

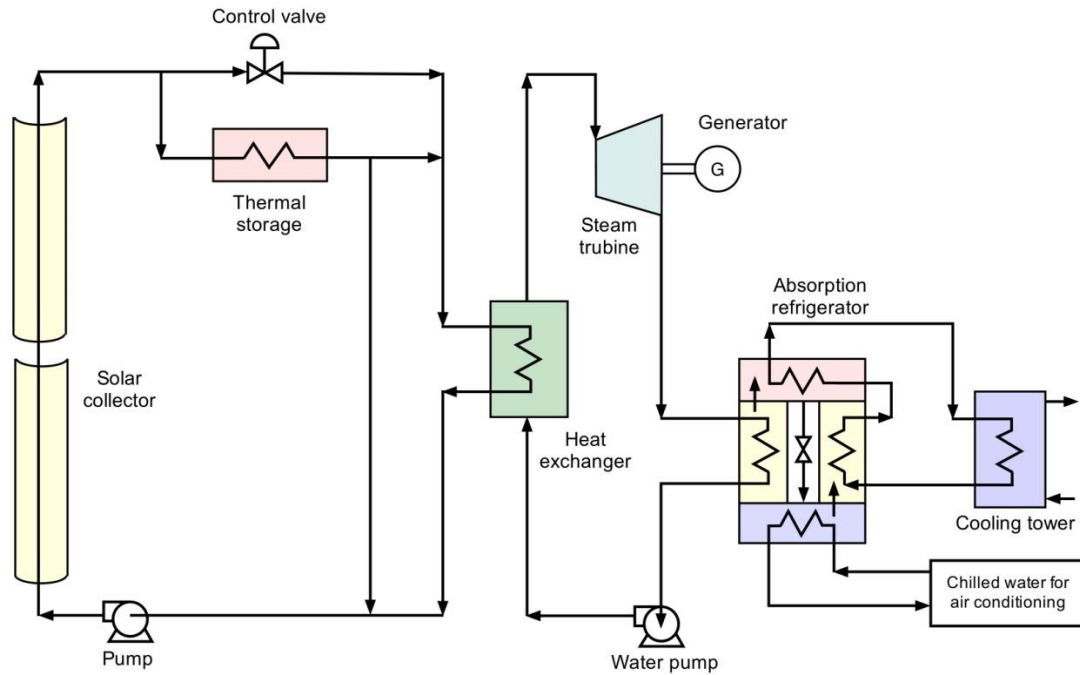

Figure 1 Schematic diagram of solar co-generation system

evacuated for reducing the convection heat loss [17]. The convection heat loss from the collector tube may be neglected because of this vacuum insulation layer. Solar radiation from concentrated parabolic trough mirror is approximated as uniform radiation around the tube circumference with the same total heat transfer rate. An axisymmetrical model for collector metal tube shown in Figure 2 is created using commercially available finite element method software [18].

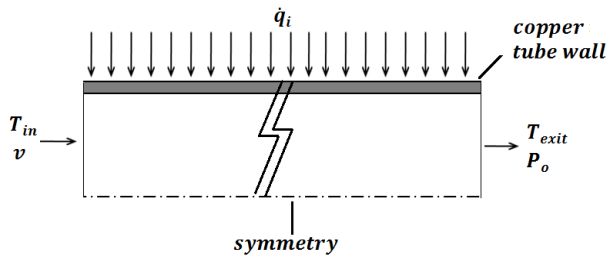

Figure 2 Axisymmetrical model of collector tube (not to scale)

When the thermal properties of the metal tube material and working fluid are approximated as constant, transient heat conduction and convection equations are linear equations. Because of this linearity, the temperature rise is proportional to the heat flux. Also, temperature rise caused by multiple heat flux pulses can be obtained by superimposing the temperature rise caused by each heat flux pulse. The fluctuating solar radiation can be considered as a series of heat flux pulses with different magnitude. The working fluid mean temperature at the exit of the collector tube at time t , $T_{predicted,t}$ may be calculated

as a summation of temperature rise caused by each heat flux pulse, stated in Eq. 1.

$$T_{predicted,t} = T_{in} + \sum_{i=1}^n \Delta T_{i,t} \quad (1)$$

where T_{in} is the inlet fluid temperature, $\Delta T_{i,t}$ is the exit working fluid temperature rise at time t caused by the i th heat flux pulse and n is the total number of the heat flux pulses. At each time step, the exit working fluid temperature is calculated by Eq. 1.

The metal tube, which exists between the outer surface boundary and the working fluid, stores heat energy temporary before it is conducted to the working fluid. The stored heat is calculated based on the temperature difference between the tube material and working fluid as in the next equation. The stored heat within the metal tube material is calculated as in Eq. 2.

$$q = mc\Delta T \quad (2)$$

Where q is the stored heat within the tube material during the current time step, m is the mass of the tube, c is the specific heat of the tube material, and ΔT is the tube temperature difference between the present and previous time steps. To compensate the temporary stored heat energy, q is subtracted from the heat pulse of the next time step.

Although the radiation heat loss was neglected in the superposition process, the radiation heat loss, Q_{loss} , is incorporated by reducing the predicted radiation heat loss from the heat pulse in the next time step.

Radiation heat loss from the tube outer surface is calculated as in Eq. 3.

$$Q_{loss} = \sigma \epsilon (T_{sur}^4 - T_{surr}^4) \quad (3)$$

Where σ is the Stefan-Boltzmann constant, ϵ is the emissivity of the collector tube outer surface, T_{sur} is the tube outer surface temperature and T_{surr} is the surrounding temperature.

Transient conjugate heat transfer analysis is performed to compute the exit temperature of collector tube cause by a single heat flux pulse. Physical size of collector and simulation parameter is presented in Table.1, which is partly adopted from Wang et al. [12]. The $k-\omega$ turbulence model is used in the fluid flow simulation. One-minute interval arbitrary heat flux distribution in this study is based on the global horizontal irradiation (GHI) measured at Universiti Teknologi Malaysia, Kuala Lumpur (longitude 101.72°E, latitude 3.17°N) with 10-minute interval. With a solar parabolic trough, only the direct normal irradiance (DNI) is concentrated. The DNI is calculated from the Eq. 4 using the measured GHI.

$$GHI = DNI * \cos(sza) + \text{diffuse radiation} \quad (4)$$

Diffuse radiation is assumed to be 30% of the GHI [19]. The solar zenith angle, sza is calculated from Eq. 5 and 6 [20].

$$\cos(sza) = \sin(lat) \cdot \sin(dec) + \cos(lat) \cdot \cos(dec) \cdot \cos(ha) \quad (5)$$

$$\begin{aligned} dec = & [0.006918 - 0.399912 \cos(\beta) \\ & + 0.070257 \sin(\beta) \\ - & 0.006758 \cos(2\beta) \\ + & 0.00907 \sin(2\beta) \\ - & 0.002697 \cos(3\beta) \\ + & 0.00148 \sin(3\beta)] \cdot (180/\pi) \end{aligned} \quad (6)$$

Where β is defined as $2\pi d/365$ radians, and d is the day of the year, ha is hour angle and lat is latitude of the location. The concentration ratio is calculated based on the area of collector aperture divided by area of collector aperture.

3.0 RESULTS AND DISCUSSIONS

Figure 3 shows the transient thermal response of the collector tube exit temperature for a constant heat flux. It takes about 400 seconds to reach the steady state condition. Since it is expected that the solar radiation fluctuates within less than 60 seconds. The solar radiation changes before the collector tube reaches to the steady state.

Figure 4 shows a heat flux pulse and the corresponding collector tube exit temperature. It takes more than 600 seconds for the fluid temperature to come back to the initial temperature. Figure 5 shows the heat flux on a typical day. The corresponding collector tube exit temperature

predicted by the proposed method is shown in Fig. 6, which capture the trend well when compared with a finite element analysis result. The exit temperature of

Table 1 Physical parameters of the collector (partly adopted from [12])

Description	Specification
Focal length	1.71 m
Aperture width	5.77 m
Concentration ratio	82
Collector material	Copper
Collector length	200 m
Collector inner diameter	0.065 m
Collector outer diameter	0.07 m
Collector emissivity	0.1
Working fluid	Therminol VP-1
Inlet temperature	298 K
Velocity	1.2 m/s
Boundary condition	Concentrated heat flux
Ambient temperature	303 K

Collector tube is highly dependent on solar radiation as originally expected. The predicted collector tube temperature tends to be higher than the finite element analysis result with the largest error of 38.8K, while the average error is 7K. The large discrepancy between the predicted temperature and finite element analysis result is located in the period where the heat flux is relatively high. It is expected that the major cause of this error is from the radiation heat loss where the tube material temperature is under estimated. Currently, the proposed methodology is being enhanced to improve the prediction accuracy. At the same time, an artificial neural network is being implemented to predict the temperature rise caused by a heat flux pulse.

In order to identify the performance of parabolic trough solar collectors at an early design stage, transient thermal simulation equivalent to at least one-year operation is required. It is not practical to perform the conventional transient thermal simulation because of the long computational time. Since the proposed methodology requires simple summation operations, it needs much less computational time than the conventional methods.

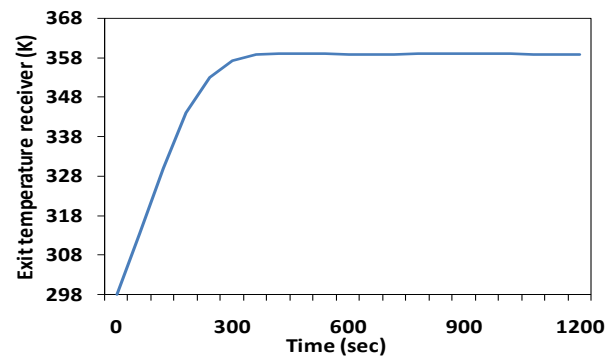

Figure 3 Thermal response for constant heat flux of 10000 W/m²

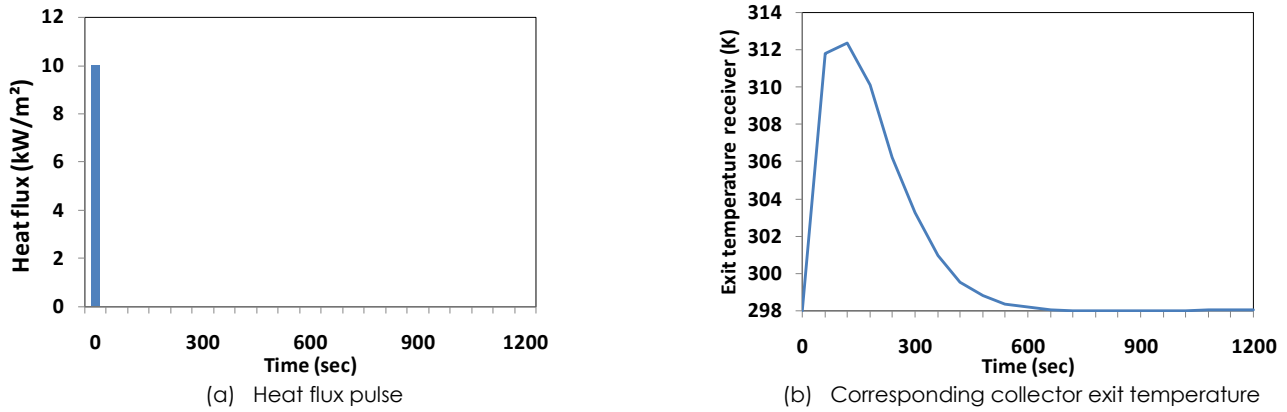

Figure 4 Heat flux pulse and corresponding collector exit temperature obtained by FEM analysis

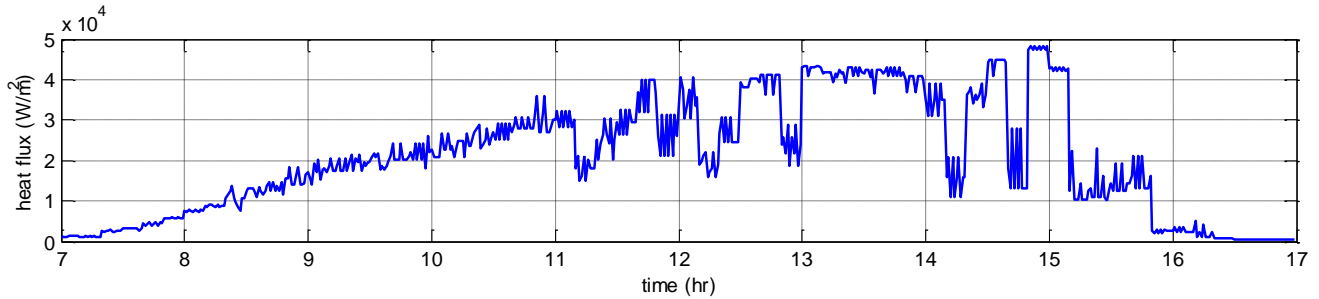

Figure 5 Fluctuating heat flux used for collector tube exit temperature prediction

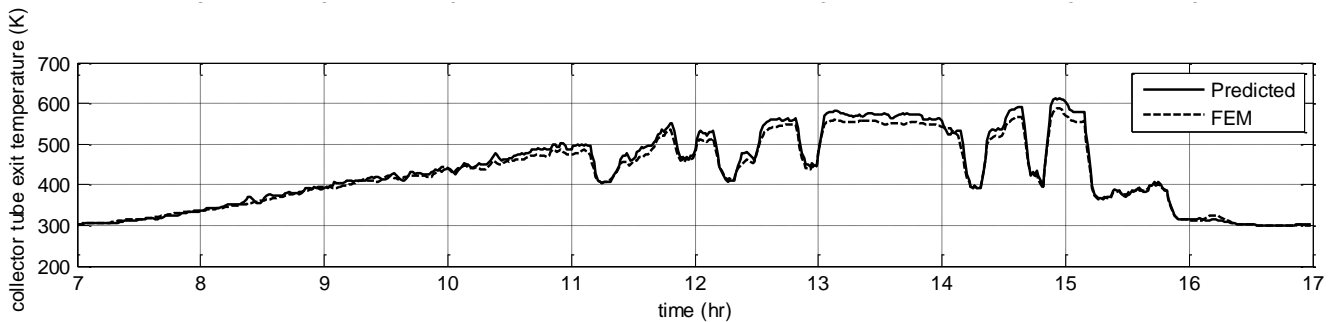

Figure 6 Predicted collector tube exit temperature compared with FEM result

4.0 CONCLUSION

A methodology to predict parabolic trough solar collector transient thermal performance is proposed. As the proposed methodology is based on the superposition principle where only simple vector operations are required, significant calculation time reduction is accomplished compared to the conventional transient thermal analysis methods. This methodology is intended to be used at an early design stage where a fast but reasonably accurate transient thermal performance prediction technique is needed. To demonstrate the capability of the proposed methodology, a solar collector tube exit temperature equivalent of one-day operation is predicted. The predicted result captures the trend well

when it is compared with a result from transient finite element analysis. Currently, the methodology is being improved to reduce the prediction error and increase the prediction capabilities.

Acknowledgement

The authors would like to express their appreciation to Takasago Thermal Engineering Co, Ltd., Japan, for providing financial support for this workthrough Takasago Education and Research Grant.

References

- [1] Mekhilef, S., Safari, A., Mustafa, W., Saidur, R., Omar, R. and Younis, M. 2012. Solar Energy In Malaysia: Current State And Prospects. *Renewable and Sustainable Energy Reviews*. 16: 386-396.
- [2] Shekarchian, M., Moghavvemi, M., Motasemi, F., Zarifi, F. and Mahlia, T. 2012. Energy And Fuel Consumption Forecast By Retrofitting Absorption Cooling In Malaysia From 2012 to 2025. *Renewable and Sustainable Energy Reviews*. 16: 6128-6141.
- [3] Baharoon D. A., Rahman H. A., Omar W. Z. W. and Fadhil S. O. 2015. Historical Development Of Concentrating Solar Power Technologies To Generate Clean Electricity Efficiently—A Review. *Renewable and Sustainable Energy Reviews*. 41: 996-1027.
- [4] Zaversky F., Medina R., García-Barberena J., Sánchez, M. and Astrain, D. 2013. Object-Oriented Modeling For The Transient Performance Simulation Of Parabolic Trough Collectors Using Molten Salt As Heat Transfer Fluid. *Solar Energy*. 95: 192-215.
- [5] Padilla R. V., Demirkaya G., Goswami D. Y., Stefanakos E. and Rahman, M. M. 2011. Heat Transfer Analysis Of Parabolic Trough Solar Receiver. *Applied Energy*. 88: 5097-5110.
- [6] Lei D., Li, Q., Wang Z., Li J. and Li J. 2013. An Experimental Study Of Thermal Characterization Of Parabolic Trough Receivers. *Energy Conversion and Management*. 69: 107-115.
- [7] Cheng Z.-D., He Y.-L. and Qiu Y. 2015. A Detailed Nonuniform Thermal Model Of A Parabolic Trough Solar Receiver With Two Halves And Two Inactive Ends. *Renewable Energy*. 74: 139-147.
- [8] Lu J. F., Ding J., Yang J. P. and Yang X. X. 2013. Nonuniform Heat Transfer Model And Performance Of Parabolic Trough Solar Receiver. *Energy*. 59: 666-675.
- [9] He Y.-L., Xiao J., Cheng Z.-D. and Tao, Y.-B. 2011. A MCRT and FVM Coupled Simulation Method For Energy Conversion Process In Parabolic Trough Solar Collector. *Renewable Energy*. 36: 976-985.
- [10] Wirz M., Roesle M. and Steinfeld A. 2012. Three-Dimensional Optical And Thermal Numerical Model Of Solar Tubular Receivers In Parabolic Trough Concentrators. *Journal of Solar Energy Engineering*. 134: 041012.
- [11] Hachicha A., Rodríguez I., Capdevila R. and Oliva A. 2013. Heat Transfer Analysis And Numerical Simulation Of A Parabolic Trough Solar Collector. *Applied energy*. 111: 581-592.
- [12] Wang Y., Liu Q., Lei J. and Jin H. 2015. Performance Analysis Of A Parabolic Trough Solar Collector With Non-Uniform Solar Flux Conditions. *International Journal of Heat and Mass Transfer*. 82: 236-249.
- [13] Ahmed M. H. 2014. Two Dimension Numerical Modeling of Receiver Tube Performance for Concentrated Solar Power Plant. *Energy Procedia*. 57: 551-560.
- [14] Yılmaz İ. H. and Söylemez M. S. 2014. Thermo-Mathematical Modeling Of Parabolic Trough Collector. *Energy Conversion and Management*. 88: 768-784.
- [15] Siqueira A. M. d. O., Gomes P. E. N., Torrezani L., Lucas E. O. and Pereira G. M. d. C. 2014. Heat Transfer Analysis and Modeling of a Parabolic Trough Solar Collector: An Analysis. *Energy Procedia*. 57: 401-410.
- [16] Hirsch T., Eck M. and Steinmann W. 2005. Simulation Of Transient Two-Phase Flow In Parabolic Trough Collectors Using Modelica. *Proceedings of the Fourth International Modelica Conference*. 403-412.
- [17] Forristall R. E. 2003. *Heat Transfer Analysis And Modeling Of A Parabolic Trough Solar Receiver implemented in engineering equation solver*. National Renewable Energy Laboratory.
- [18] COMSOL. 2015. Introduction to COMSOL Multiphysics 5.1. [Online].From: <http://cdn.comsol.com/documentation/5.1.0.180/IntroductionToCOMSOLMultiphysics.pdf>. [Accessed on 17 September 2015].
- [19] Ahmad M. H., Ossen D. R. and Chia S. L. 2004. Impact Of Solar Radiation On High-Rise Built Form In Tropical Climate.
- [20] Vignola F., Michalsky J. and Stoffel T. 2012. *Solar And Infrared Radiation Measurements*. CRC Press.