

## THE EFFECTS OF CONTINUOUS LIGHTING (CL) METHOD ON THE GROWTH DEVELOPMENT OF BRASSICA CHINENSIS FOR LED PLANT FACTORY IN WSN APPLICATION

Ahmad Nizar Harun\*, Robiah Ahmad, Norliza Mohamed

Razak School of Engineering and Advanced Technology,  
Universiti Teknologi Malaysia (UTM), 54100, Jalan Semarak,  
Kuala Lumpur, Malaysia

### Article history

Received

26 November 2015

Received in revised form

14 January 2016

Accepted

10 October 2016

\*Corresponding author  
nizar.harun@mimos.my

### Graphical abstract



### Abstract

This study was performed to investigate the best practise on using LED light for optimum growth of Brassica Chinensis and reduce turn around time at different kind of photoperiod study utilizing Wireless Sensor Network (WSN) technology as remote monitoring system. Growth performance of Brassica Chinensis under two different wavelengths (blue and red) 16:4 as light source has been used to determine plant growth performance and phytochemicals aspect of plant characteristics. Two experiments were conducted which is the pulse treatment (1 hour light and 1 hour dark) and continuous light (CL) photoperiod treatment in both trials. Observation such as leaves count, height, dry weight and chlorophyll I & II of both plants were analysed. It was noted that the CL photoperiod has significant effect on overall growth performance and remarkably lead to improve the efficiency of the plant factory. In order to reason on data and monitor the environmental parameters of the plant factory, an intelligent system using embedded system has been developed to automate the LED control and manipulation. The result shows that the system is stable and has referential significantly in the area of plant factory or indoor farming system.

**Keywords:** Indoor Farming, Plant Factory, Wireless Sensor Network, Continuous Lighting, LED Light Spectrum, Sensor, and Intelligent Control Farming

© 2016 Penerbit UTM Press. All rights reserved

## 1.0 INTRODUCTION

Optimization work to reduce turn around time to obtain optimum output in plant factory is a major challenge in many developing and underdeveloped countries, typically it was done in close environment. Problem associated with cultivation of vegetables crop under direct sunlight will eventually reduce its quality and indoor farming is the new approach to address this issue [1]. Close loop system approach or plant factory has been introduced recently to optimize the plant growth, increase yield and flowering control [2]. There is a continual interest in seeking new ways to manipulate plant growth and the concern about short day (SD) and long day (LD) plant was always taken into consideration before any experiment conducted. Typical of living organism has endogenous circadian clock that generates a circadian rhythm with periodically about 24 hour, which synchronized with external environment and regulate physiological process of the organism. In example, travelling to time

different zone from east to west which will caused the phenomena of "jet lag" is quite common whereby the circadian rhythm generated by endogenous circadian rhythm located in brain and resynchronized to different time zones for human [3]. In contrast, in plants the indigenous clock functions at the level of individual cell, the circadian rhythm regulates the timing of gene expression such as photosynthesis genes from early morning to noon [4].

The regulation of physiological processes by the endogenous circadian clock in plants is circadian resonance (CR) [5], which matches the periodicity of the plant circadian rhythm to the external light-dark cycle and thereby maximizes aerial weight [6]. The findings of that study not only demonstrated that the circadian clock affects plant growth, but that it may also be possible to exploit the circadian clock to control plant growth [7]. The studies on CR, changing the period of the light dark cycle by just 4 h reduced plant growth by approximately 50% [8], implying that precise control of the light environment is required for

CR generation. However, relatively few studies have examined the role of CR in plants other than *Arabidopsis thaliana*, and it is not known whether this role holds the potential to apply in other agricultural products or plants.

Wireless Sensor Networks (WSN's) are used in many areas and applications such as home security, disaster prevention, landslide monitoring, tsunami or hurricane monitoring and environmental monitoring [9]. WSN often used in project that needed network system with many sensors attached to wireless communication and powered by small battery. WSN has capability to self organized the network; consist of nodes, relay nodes and gateway. Relay node is used to extend the network, while gateway is deployed to increase the coverage of the network to wide area network (WAN) [10]. Moreover, WSN can be found in feedback and control system. For example WSN is used to monitor green house area in agriculture industries. WSN is architecture able to detect environmental data from various sensors, collect and process data locally or remotely and transmit the sensed information to a server [11].

Plant growth is strongly influenced by the light spectrum and duration, which refers to the wavelength reaching a plant's leaf surface [12]. Red (R) and blue (B) lights have the primary impact on plant development because they are the major wavelength that contribute energy for photosynthetic CO<sub>2</sub> assimilation in plants and widely produced by LED manufacturer for plant growth solution [13]. It is well known spectrum that have highest action in photosynthesis activities typically in respond to chlorophyll a and b. Combination of RB LED lights already proven to be an operational lighting source for producing vegetables and other species, including *Brassica Chinensis* in indoor farming's environments.

In this study, we tried to investigate the occurrence and effects of CR in *Brassica Chinensis*; the present study employed an artificial light, hydroponic culture system to accurately control the growing environment. The experiments utilized red and blue light LEDs as the light sources. In *Brassica Chinensis*, the effect of LED illumination has been demonstrated that the period of circadian rhythms tended to be at 24 h [14]. When considered in conjunction with CR characteristics, this shortening of the circadian rhythm suggests that plant growth could be increased using short period light dark cycles.

The objective of this study was to develop a method for stimulating the growth of *Brassica Chinensis* in the Plant Growth Chamber (PGC) using LEDs, and to find the relation between light environment and morphogenesis of the plant. The knowledge obtained will be used to design lighting technique to stimulate growth and develop a control technique for plant manipulation. With this knowledge, scientists have changed their positions to active and tried to induce expected consequences by imposing artificial light manipulation to plants using LED light. These artificial light manipulations include modern machine such as wireless sensor network (WSN), android base application and data acquisition to log and reason on data or decision support system (DSS) and by using big data analysis tools or similar approach, it can be also

able to do forecasting and prediction capability on plant growth rate performance.

## 2.0 METHODOLOGY

The system architecture used for this experiment was designed based on latest the art of technology.. Dash-7 radio has been selected to be the wireless sensor network services transporting data from sensor nodes utilising 433 Mhz frequency, which is suitable for indoor farming to overcome building-to-building penetration. The data will be broadcast via Bluetooth and able to pick-up easily by smart phone and also used as to trigger actuator and relay for feedback system. The overview of the system diagram of system is shown in Figure 1.

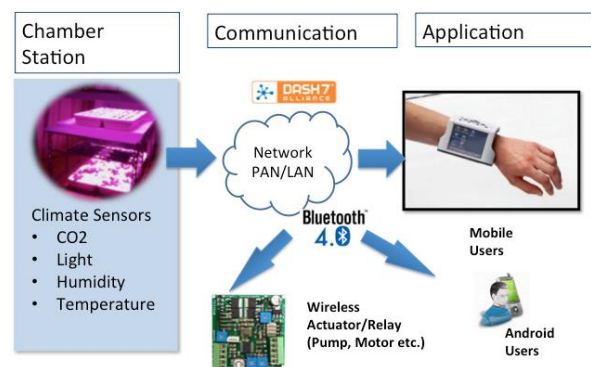

Figure 1 Block diagram of the system architecture

### 2.1 Monitoring and Control System Design

The main function of monitoring system design is to log and keep the data for analysis purpose and will be used to reason on data for data harvesting and data crunching exercise. 2 methods have been used to ensure the data is easily accessible. Android apps and Windows PC data logger has been developed for this purpose. The control system design, which consists of Controller Area Network (CAN) bus, a controller and actuator, will feedback to ensure the desired temperature and humidity is constant during the entire experiments. There are 4 main sub systems that have been developed in this experiment to cater for existing and future experiment to be conducted.

#### 2.1.1 Microcontroller Module:

The system used 2 microcontrollers (Atmega2560) located at main board and slave board. The main controller-1 is taking care the communication part while the Controller-2 is taking care the feedback system. Controller-1 and 2 is linked by UART channel to perform machine-to-machine communication. The whole block diagram of the hardware arrangement is shown in Figure 2.

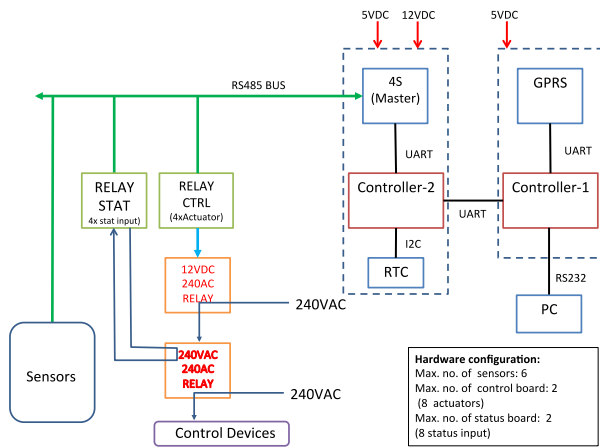

Figure 2 Block diagram of the system

2.1.2 Data Acquisition System

Android platform development using B4a using visual basic language has been chosen to perform data logging and remote monitoring. The data was transported to MySQL database using JSON protocol and was processed by PHP programme to process the incoming GPRS data string from sensors. The apps able to produce real time graph and data monitoring. The Android base application GUI shown in figure 3.

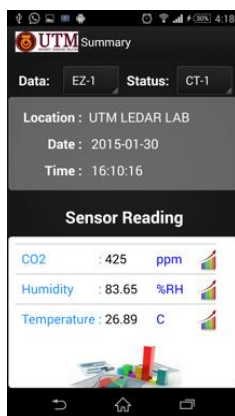

Figure 3 The Android base application for remote monitoring

2.1.3 Wireless Sensor Nodes

Sensor module consists of temperature, humidity, and CO<sub>2</sub> and Photosynthetically Active Radiation (PAR) sensors. The PAR light sensor can measure the spectral range of solar light from 400 to 700 nanometers. Data of each sensor is transmitted using Zigbee module in JSON format. The detail information on sensors used as below:

i) Sensor tip: Consist of read out IC (ROIC) to process analogue and digital sensors. The SPI bus was used to connect to nodes after the controller compensated the incoming raw data from sensors. Compensation is to ensure the drift and coloration with measured temperature was taken care. The Li-COR Li-190, an active radiation (PAR) quantum light sensor is of the sensors connected, the signal has been amplified by low noise amplifier to 5V signal before analogue input channel in microcontroller.

ii) Actuator Module: The system solid-state relay to cater for incoming 5V direct triggering from IO microcontroller without having voltage translator module in between. There are 4 outputs available triggered by address bus translated by secondary microprocessor. The actuator module and sensor tip have similar SPI interface and similar data protocol, differentiated by packet location only.

iii) Node: The node design was base on interchangeable tip approach consist of 2 parts, the daisy chain part and the wireless part. The daisy chain part includes CAN bus controller to extend the sensor tips capability to cascade up to 32 sensors tips and the wireless part consist of Zigbee module to send over data to control panel and later to internet cloud via http protocol. The node configuration diagram is shown in figure 4.

iv) Sensor Packet: The packet transmitted using a simple packet configuration from sensor nodes to gateway, shown in Table 1 without any encryption applied. In server site, the gateway will repacked and send the data via WiFi network or GSM modem based using server packet. Gateway will be also sending command via CAN bus to activate relay for feedback system.

Table 1 Sample packet use in communication

Transmission Mode	Sample Packet
Sensor Node to Gateway	"{TIP:EZ-1,Date:01062015,Time:205943,T:28.52C,H:73.63%,CO2:496ppm}" <sup>a</sup>
Gateway to Actuator Node	txtTipTimestamp=2015-06-01@20:59:43 &txtTipId=EZ-1 &txtTemp=28.52&txt Humid = 73.63% &txtCO2=496 <sup>b</sup>
Gateway to Server	"{TIP:AC11,Date:01062015,Time:205943,R1:0,R2:0,R3:1, R4:1}" <sup>c</sup>

<sup>a</sup>EZ-1: Sensor type, T: temperature, H: Humidity, CO2: Carbon Dioxide  
<sup>b</sup>EZ-1: Sensor type, Temp: Temperature, Humid: Humidity, CO2: Carbon Dioxide  
<sup>c</sup>AC-1: Actuator 1, R1: Relay 1, R2: Relay 2, R3: Relay 3, R4: Relay 4,

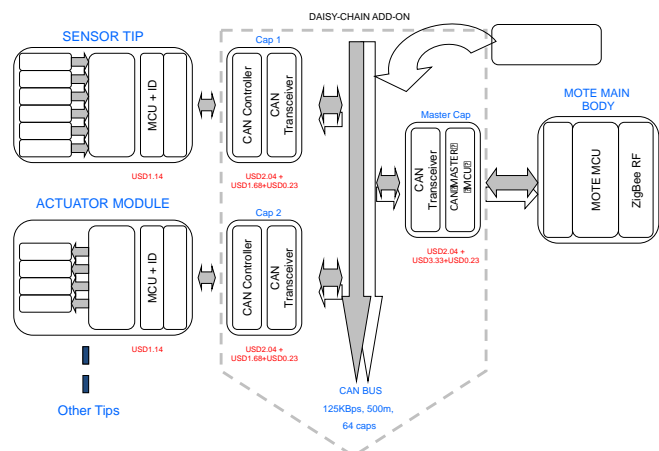

Figure 4 The nodes configuration

2.1.4 Data Sending Method

The data captured by sensors will be sending to server by https communication via Wi-Fi module (WiFly-Microchip Inc. USA) using serial bus communication

written in C++. The system will start the communication to established network with WiFly and later on try attempting to connect with server for 3 times before time out. The data saved in memory, which contents set of data, was sorted for ease of the decoding process afterward. This refers to putting the set of data into a predetermined order and will be posted to database after hand shaking established with PHP JSON converter. The function of the communication is shown in Routine 1.

**Routine 1** HTTP Post command to send data to server  
 void updateMiMist(unsigned char \* ip\_data, int ip\_data\_len)  
 {

```

char ret=0;
char cmd_retry = 0, server_retry=0;
boolean wifly_status=false, server_status=false;
int i;
Serial.print(F("\nPosting data to mi-mist server...\n"));
Serial2.print(F("\nPosting data to mi-mist server...\n"));
while (cmd_retry++ < 3) {
    if( sendWiflyCmd((unsigned char *)"$$$", "CMD", "ERR",
    7000) == 1) {
        wifly_status = true;
        delay(1000);
    }
    // CONFIG FOR SENSOR DATA STORAGE
    if( wifly_status) {
        while (server_retry++ < 3) {
            if( sendWiflyCmd((unsigned char *)"open 192.168.11.103
            3008 \r", "*OPEN*", "FAILED", 7000) == 1) {
                Serial2.print(F("\nConnect OK"));
                server_status = true; }
            if (server_status){
                Serial3.print(F("POST /weather HTTP/1.1\n"));
                Serial3.print(F("Host: 192.168.11.103\n"));
                Serial3.print(F("Connection: close\n"));
                Serial3.print(F("Content-Type: application/x-www-form-
                urlencoded\n"));
                Serial3.print(F("Content-Length: "));
                Serial3.print(ip_data_len);
                Serial3.print(F("\n\n"));
                for(i=0; i < ip_data_len; i++)Serial3.write(*(ip_data+i));
                server_retry = 4; //if successfuf, end retry
            }else {
                Serial2.print(F("\nConnect FAILED...retry="));
            }
            if(server_retry < 4) {
                Serial2.println(server_retry, DEC);
            }
        }
        cmd_retry = 4;
    }else {
        Serial2.print(F("\nWifly not responding...retry="));
    }
    if(cmd_retry < 4) {
        Serial2.println(cmd_retry, DEC);
    }
    }
    resetWDT();
    ret = sendWiflyCmd((unsigned char *)"exit\r", "EXIT", "",
    5000);
    Serial2.print(F("\nWifi send completed.));
    
```

**2.1.4 Light Source Module**

Two LED systems were used, namely: T1: 10 units of 20 W (12 hours light and 12 hours light off, the red/blue LED ratio is 16:4 and T2: 10 units of 20 W (24 hours light) the red/blue LED ratio is 16:4. The LED source has been configured by factory to optimum the photosynthesis

activities at peak level chl a (red spectrum at 460nm) and chl b (blue spectrum at 660nm). There are 20 LEDs in each row and 10 rows were used for this experiment with total power at 200W. The photoelectric parameter and operation hour of led is shown in Table 2.

**Table 2** Photoelectric parameter of led source

LED	Peak wavelength (nm)	Ratio	LED Power (W)	Operation Period (hour)
T-1 Red	460	16	160	12(1L/1D)
T-1 Blue	660	4	40	12(1L/1D)
T-2 Red	460	16	160	24(CL)
T-2 Blue	660	4	40	24(CL)

**2.2 Experimental Design**

Experiment was conducted in 2 separate chamber rooms, which is trial 1 (T1-Pulse light treatment) and trial (T2-Continuous light treatment), located at Universiti Technology of Malaysia, Jalan Semarak, Kuala Lumpur, Malaysia. The plant is hydroponically grown and no pesticides were used during the experiments. Special formulation was developed by Mardis Berhad which slightly high in Nitrate content to accommodate low intake in led plant growth chamber directly related to low temperature growing condition compared to typical sunlight condition. The formulation is shown in Table 3.

**Table 3** Fertilizer Formulations<sup>a</sup>

Entry	Catalysts	Weight	Unit
1	Mono-Potassium Phosphate <sup>c</sup>	4	Kg
2	Magnesium Sulphate <sup>c</sup>	6	Kg
3	Magnesium Nitrate <sup>c</sup>	3.7	Kg
4	Copper EDTA (Cu14%) <sup>c</sup>	35	g
5	Zinc EDTA (Zinc 14%) <sup>c</sup>	75	g
6	Manganese Sulphate (Mn 31%) <sup>c</sup>	30	g
7	HiBOR (B 19%) <sup>c</sup>	75	g
8	Sodium Molybdate (Mo 39%) <sup>c</sup>	4	g
9	Calcium Nitrate <sup>b</sup>	12.5	Kg
10	Ferrous EDTA <sup>b</sup>	90	g
11	Potassium Nitrate <sup>c</sup>	6	Kg

<sup>a</sup>Chemicals mixing were carried out at 25 °C and diluted in 100 liter of water

<sup>b</sup>Fertilizer elements which stored inside A storage before mixing and separated from storage B due calcium will interact with fertilizers B containing sulfates or phosphates.

<sup>c</sup>Minor elements which stored inside B storage before mixing

Seeds of *Brassica Chinensis* (F1 hybrid seed of Siew Pak Choy) were germinated in sponge cube (2.3cm x 2.5cm x 2.0) and hydroponically grown in dark room for 3 days and 4 days with RB 16:4 12 hour day light (no fertilizer, water only). The plant was transplanted to fertilizer tank after 7 days and were individually raised in plastic cup with hole, then mounted into a Styrofoam plate with eight holes, and placed in a container (52 cm x 40 cm x 11 cm) filled with above nutrient solution and hydroponically grown for 30 days in an environmentally controlled growth room. The temperature was at a constant 24°C under a light intensity of approximately 100  $\mu\text{mol m}^{-2} \text{s}^{-1}$  photon flux density (PFD), relative humidity at 60% and CO<sub>2</sub> level at 420ppm. Proper ventilation inside the chamber was done to maintain level of CO<sub>2</sub> and was observed periodically. The hydroponic nutrient (major and minor elements) solution was renewed every week and adjusted to pH 5.6 to 6 and an electrical conductivity of 2.5 mScm<sup>-1</sup>. The light duration was maintained at 12h (T1) and 24hr (T2) using LED light sources with Red and Blue RB (R: 660 ± 30 nm and blue (B: 430± 30nm) ratios. The air temperature (T), relative humidity (RH), and CO<sub>2</sub> levels for all treatments were respectively maintained. The plants were observed physically and were harvested after 30 days.

### 2.3 Light Recipes

Treatments with twenty four replicates consisted of two commercially available light sources: (1) RB LEDs with 1 hour light and 1 hour dark, (2) RB LEDs with Continuous Light (CL, as the control). All light LED lights were from Shenzhen Bysen Semiconductor Lighting Co. Ltd., China. The peak emissions of the B (450 nm) and R (620 nm) LEDs closely correspond with the absorption peaks of chlorophylls a and b, and the suitable wavelengths are at their respective concentrated photosynthetic efficiency [15]. The wavelength and spectral energy distribution recorded using LI-190 calibrated with spectroradiometer LI-COR1800 placed horizontally in the on the table at similar height at the plant canopy. The treatments differentiated by a 1/1-h light/dark and 24h light (CL) photoperiod and the same light intensity expressed as photosynthetic PFD of 100  $\mu\text{mol m}^{-2} \text{s}^{-1}$  which was measured daily above leaf area and no maintenance was perform to the distance of the LEDs to the plant height. Plants were harvested at 30 days after sowing (DAS).

### 2.4 Plant Growth Measurement

Measurements included physical, yields and Gas exchange. As a physical measurements plant height (PH) and no of leaf (NOL) were recorded during the growth while leaf area (LA) after harvesting *Brassica Chinensis* after 30 days. Total yields were measured by fresh weight (FW), dry weight (DW) and moisture content (MC). Plant tissue samples were dried in a drying oven for 48 h at 65°C before weighing. The LA (cm<sup>2</sup>) of every plant was measured by an LA meter (LI-3100, LI-COR). Survival rate was counted at the end of the experiment.

### 2.5 Chlorophyll (chl) Measurement

Chl were evaluated from the shoot FW samples (0.1 g) with 20 mL 80% acetone at 4°C overnight and determined by the methods of Porra et al.[16]. The sample was then keep in the bottle in the dark room until the leaf changes their colour to white. The supernatant was applied to determinate the absorbance of chl a and chl b in acetone, as measured with Optical density was measured with a UV 3101PC Scanning Spectrophotometer at 470 nm for chlorophyll a and at 645 nm for chlorophyll b [17]. Concentrations of chl a and chl b was determined from the following Equations 1 [14]:

$$\begin{aligned} \text{Total chlorophyll (mg/l)} &= 20.2 D_{645} + 0.02 D_{663} \\ \text{Chlorophyll a} &= 12.7 D_{663} + 2.69 D_{645} \\ \text{Chlorophyll b} &= 22.9 D_{645} + 0.02 D_{663} \end{aligned} \quad (\text{Equation 1})$$

### 2.6 Statistical Analysis

Photosynthetic responses were measured using a Portable Photosynthesis System Li-6400XT (LICOR, USA) whereby statistical analyses were performed with statistical tools and service solutions for Windows platform, version 16.0 (SPSS) [18]. All measurements and data were evaluated for significance by an analysis of variance (ANOVA) followed by the least significant difference (LSD) approach and test at the  $p < 0.05$  level [18,19].

## 3.0 RESULTS AND DISCUSSION

### 3.1 Survival Rate, Yield, Quality And Chlorophyll

Survival rate was observed for 30 days experiment, both trial showing no significant different at the end of the day and but total yields of 48 samples for *Brassica Chinensis* under CL were significantly higher than under Pulse and there are significant different among them. Results of the biomass measurement of *Brassica Chinensis* influenced by duration of light treatments are shown in Table 3. Plant showed significant growth responds to light duration with higher light exposure duration. FW and DW of the plants were the highest when grown under CL treatment. The NOL was also increased by 13% with the CL treatment associated to the Pulse control. The LA was also showing better performance in the CL treatment, which is 13% better than the Pulse treatment. In contrast, a typical appearance and morphology with vigorous roots of the *Brassica Chinensis* plants CL treatment were also observed. Plants growth under CL treatment observed big, directly related to PH with 11% improvement supported by the big root condition. However, plants that grown under Pulse have shown slightly increased in figure in moisture content compared to CL by calculating the mean of FW and DW data (% of FW/DW physical measurement) from Table 4.

Chl b content of *Brassica Chinensis* in all treatments was higher than the respective chl a contents. In addition, total chl shown under CL was higher than under Pulse and there are significant different among them.

3.2 Photosynthesis

Mean leaf photosynthesis periodic rate of *Brassica Chinensis* that been induced to CL in different photoperiod are shown in Figure 6. In addition, plants grown below CL increase in mean value of 5.09  $\mu\text{mol CO}_2\text{ m}^{-2}\text{ s}^{-1}$  compared to Pulse values of 4.34  $\mu\text{mol CO}_2\text{ m}^{-2}\text{ s}^{-1}$ . Leaf of plant exposed for both treatments indicates that there were significant ( $p < 0.05$ ) differences between the both treatments. On the other hand, the periodical mean leaf transpiration rate of *Brassica Chinensis* under CL and Pulse in contrast photoperiod is shown in Figure 6. Photosynthesis responses for CL pointed the higher rate transpiration rate when compared to Pulse. The results of the statistical comparison between mean of treatments for 30 days indicate that there were significant ( $p < 0.05$ ) differences between both treatments in weekly data recorded by Li-6400 data logger and can be exported to Microsoft Excel file.

The periodical means of leaf stomata conductance of *Brassica Chinensis* under two different treatments are showed in Figure 6. Figure value for plants grown under CL conditions state that it higher compared to Pulse. The stomata conductance values were relatively higher for plants under Pulse system, which also promotes higher photosynthesis activity of the plants irrespectively. Due to the impact of stomata opening this maintained and holds photosynthetic efficiency without much significant shift in photoperiod. The result of the statistical analysis of treatment means for 30 days in different photoperiodic revealed that there were significant ( $p < 0.05$ ) differences.

The periodical mean leaves of water use efficiency (WUE) for *Brassica Chinensis* under respective levels of photoperiods are shown in Figure 6. Data recorded for CL was higher in WUE values compared to Pulse lighting system, hence, evidence that photoperiod influenced the WUE of plants substantially. Moreover, plants that been exposed under CL system showed lower values of WUE 1.79 compared to Pulse with 1.51 at week 3 observation. The result from this comparison of treatment means for 30 days showed that that there were significant ( $p < 0.05$ ) differences between both treatments. In contrast both treatment were not having stress symptom such as burn mark due to heat stress or abnormal growth. The leaves were also maintaining good moisture at both treatments without any drop off during the exsperiment conducted.

**Table 4** Influence of treatment on FW, DW, LA, chl a, chl b, and total chl at 30 days after sowing<sup>a</sup>.

Parameter	Photoperiod 16:2 RB	
	Pulse	CL
FW (g)	62.71 <sup>a</sup>	88.55 <sup>b</sup>
DW (g)	31.11 <sup>a</sup>	47.02 <sup>b</sup>
MC (%)	50.39 <sup>a</sup>	46.90 <sup>b</sup>
PH (cm)	10.12 <sup>a</sup>	11.35 <sup>b</sup>
NOL	11.25 <sup>a</sup>	15.25 <sup>b</sup>
LA (cm <sup>2</sup> )	7.63 <sup>a</sup>	9.25 <sup>b</sup>
Chl a	4.20 <sup>a</sup>	4.61 <sup>b</sup>
Chl b	11.15 <sup>a</sup>	12.64 <sup>b</sup>

Total Chl	9.83 <sup>a</sup>	11.15 <sup>b</sup>
-----------	-------------------	--------------------

<sup>a</sup>Means of 144 plants sample of *Brassica Chinensis* a and b: shown significant different using LSD test at  $P < 0.05$  probability level.

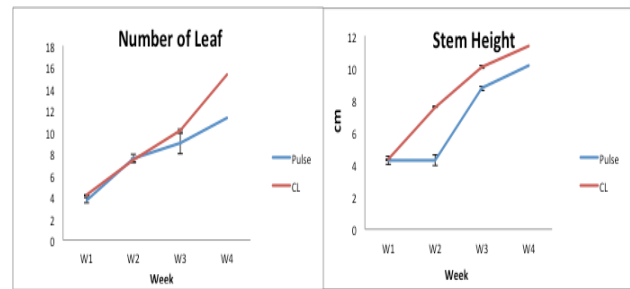

**Figure 5** The Photosynthesis measurement under RB (16:4) LED in different photoperiod was observed for 30 days. Data for *Brassica Chinensis* were hydroponically cultured represent the means  $\pm$  standard error of 8 replicate plants.

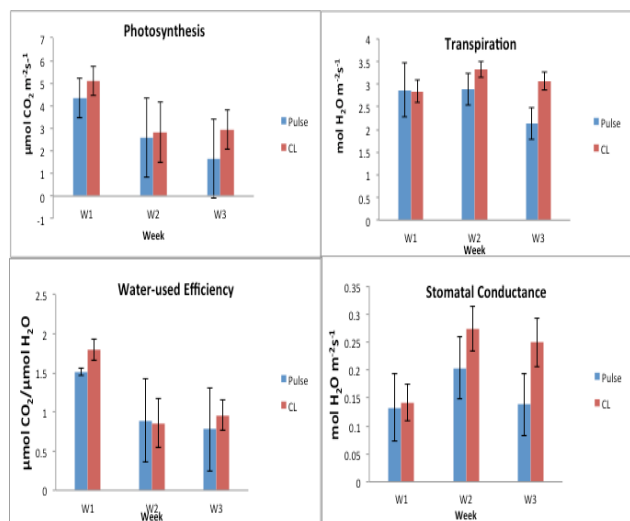
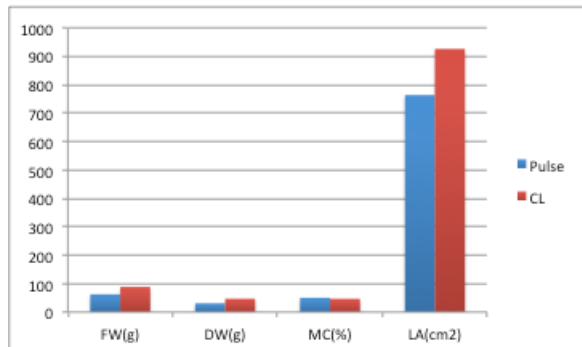

**Figure 6** The Gas Exchange was calculated under different treatments Pulse (T1) and CL (T2) for 30 days. Data for *Brassica Chinensis* were hydroponically cultured represent the means  $\pm$  standard error of 12 replicate plants.

Figure 6 shows the transpiration measurements under CL and Pulse in different photoperiod was observed for 30 days. Data for *Brassica Chinensis* were hydroponically cultured represent the means  $\pm$  standard error of 4 replicate plants. Mean leaf photosynthesis periodic rate of *Brassica Chinensis* that has been induced under RB LED is shown in Figure 6. Plants grown below both treatments were weekly increasing. Leaf of plant expose to both systems indicates that there were significant ( $p < 0.05$ ) differences between both treatments. The periodical means of leaf stomata conductance of *Brassica Chinensis* under two different treatments are presented in Figure 6. Stomata conductance for plants grown under CL conditions state that it higher compared to Pulse with in total mean values. The result of the statistical analysis of treatment means for 30 days in different treatment revealed that there were significant ( $p < 0.05$ ) differences.

The light intensity for both experiments was kept in the variable intensity condition at 100  $\mu\text{mol}^{-2}\text{s}^{-1}$  with climate control system that provide temperature

remain at 24°C and humidity at 60% RH until the end of the experiment. The CO<sub>2</sub> level inside the chamber also been monitored to ensure in enough CO<sub>2</sub> supply and fluctuated between 400 to 420ppm. The data received from wireless nodes were sent to cloud storage and viewable from Android Phone and Personal Computer.



**Figure 7** The physical measurement of Brassica Chinensis after 30 DAS

As shown in Figure 7, physical observation and condition of the plant was also recorded to understand the health of the crop every week and to record any abnormality found during the experiment. There was no abnormality found due to micro nutrient deficiency during the experiment. The biomass of *Brassica Chinensis* significantly increased with CL treatment compared to Pulse treatment directly related to enlarge LA. Exposure to CL light resulted high elongation and enhance the LA and biomass production. In the present experiments, CL treatment was shown to be inferior in physical measurement and gas exchange analysis, given new method to be introduced in plant factory. In theory, the plant growth of both trials should not be significant in results. Base on circadian rhythm theory, the hypothesis of plant is having photosynthesis from morning to noon has been concluded which is true for outdoor, however in our experimental trial in indoor farming the circadian rhythm is not being interrupted by an artificial light and study found that the circadian clock has no effect at all to *Brassica Chinensis* in indoor farming method.

#### 4.0 CONCLUSION

In agriculture industries, yield and turn around time are the two most significant criteria to be observed and optimized especially in plant factory whereby cost is the major constraint. Consumption of electricity, water and fertilizer need to be in optimum condition. The goal of our experiment is to develop a control system that able to stimulate, control and introduce new light apparatus with LEDs in plant factories. In the present study, we observed and investigated the effect of CL versus Pulse method that has proven able to reduce harvesting time in previous experiment conducted in 12hr day light system. Based on this study, it look like that the CL using RB 16:4 LEDs resulted in many good effects on plant growth and the increase of size and biomass for food production that may comply with indoor farming requirements for precise management

of crop production. Next stage, the research will be continued to study the significant output of having continuous lighting (CL) with high intensity to reduce turnaround time of harvesting time of *Brassica Chinensis*.

#### Acknowledgement

This research was supported by the Fundamental Research Grant Scheme Vot (4F144) and GUP Tier 1 Vot 04H55 by the Ministry of Higher Education (Malaysia). Gratitude also express to Razak School, Universiti Teknologi Malaysia Kuala Lumpur for providing place and equipment to complete the experiment and also technical support from Elite Scientific Instruments Sdn Bhd to complete this study using LI-COR Bioscience's technologies.

#### References

- [1] Okuda, N., Toriyama, K., Miya, Y., Yanagi, T., Yamaguchi, K., Tanaka. 2014. M.Effect Of End-Of-Day Light Irradiation Using LED Light Sources On The Growth Of Lettuce Under A High Temperature. *Environmental Control in Biology*, 52 (2): 73-77
- [2] T. Morimoto, Y. Hashimoto. 2000. AI Approaches To Identification And Control Of Total Plant Production Systems. *Control Engineering Practice*. 8(5): 555-567
- [3] Yamaguchi, Y., Suzuki, T., Mizoro, Y., Kori, H., Okada, K., Chen, Y., Fustin, J. M., Yamazaki, F., Mizuguchi, N., Zhang, J., Dong, X., Tsujimoto, G., Okuno, Y., Doi, M., Okamura, H. 2013. Mice Genetically Deficient In Vasopressin V1a And V1b Receptors Are Resistant To Jet Lag. *Science* 342: 8590.
- [4] Bredmose, Niels B. 1998. "Growth, Flowering, And Postharvest Performance Of Single-Stemmed Rose (*Rosa hybrida* L.) Plants In Response To Light Quantum Integral And Plant Population Density." *Journal of the American Society for Horticultural Science*. 123(4): 569-576.
- [5] Harmer, S. L., Hogenesch, J. B., Straume, M., Chang, H. S., Han. 2015. 53(1)
- [6] Nakamichi, N., Ito, S., Oyama, T., Yamashino, T., Kondo, T., Mizuno, T. 2004. Characterization Of Plant Circadian Rhythms By Employing *Arabidopsis* Cultured Cells With Bioluminescence Reporters. *Plant Cell Physiol*. 45: 57\_67.
- [7] Nakamichi, N., Kiba, T., Henriques, R., Mizuno, T., Chua, N. H., Sakakibara, H. 2010. Pseudo-Response Regula- Tors 9, 7, and 5 are transcriptional repressors in the *Arabidopsis* circadian clock. *Plant Cell*. 22: 594\_605.
- [8] Nakamichi, N., Kiba, T., Kamioka, M., Suzuki, T., Yamashino, T., Higashiyama, T., Sakakibara, H., Mizuno, T. 2012. Transcriptional repressor PRR5 directly regulates clock-output pathways. *Proc. Natl. Acad. Sci. U.S.A.* 109: 17123-17128.
- [9] Poppe, C., Sweere, U., Drumm-Herrel, H., Schäfer, E. 1998. The Blue Light Receptor Cryptochrome 1 Can Act Independently Of Phytochrome A And B in *Arabidopsis thaliana*. *Plant J*. 16: 465-471
- [10] Hashim, Norlezah, Mohd Amir Hafifi Abdul Razak, and Fakrulradzi Idris. 2015. "Home Security System Using Zigbee." *Jurnal Teknologi* 74(10): 29-34.
- [11] Zeb, Asim, AKM Muzahidul Islam, Sabariah Baharun, Nafees Mansoor, and Yoshiaki Katayama. 2015. "A Survey On Self-Organized Cluster-Based Wireless Sensor Network." *Jurnal Teknologi* 76(1): 347-356.
- [12] Yunus, Mohd Amri Md, Sallehuddin Ibrahim, Mohd Taufiq Md Khairi, and Mahdi Faramarzi. 2015. "The Application of WiFi-based Wireless Sensor Network (WSN) in Hill Slope Condition Monitoring." *Jurnal Teknologi* 73(3): 75-84.
- [13] Johkan, M., Shoji, K., Goto, F., Hashida, S., Yoshihara, T., 2010. Blue Light-Emitting Diode Light Irradiation Of Seedlings

- Improves Seedling Quality And Growth After Transplanting In Red Leaf Lettuce. *HortSci* 45: 1809-1814.
- [14] Cosgrove, D., 1981. Rapid suppression of growth by blue light. *Plant Physiol.* 67: 584-590.
- [15] McCree, K.J., 1972. The Action Spectra, Absorbance, And Quantum Yield Of Photosyn- Thesis In Crop Plants. *J. Agric. Meteorol.* 9: 191-196.
- [16] Porra et al. (1989) and Holm (1954), Johkan, M., Shoji, K., Goto, F., Hashida, S., Yoshihara, T., 2010. Blue Light-Emitting Diode Light Irradiation Of Seedlings Improves Seedling Quality And Growth After Transplanting In Red Leaf Lettuce. *HortSci.* 45: 1809-1814.
- [17] Lin, Kuan-Hung, et al. 2013. "The Effects Of Red, Blue, And White Light-Emitting Diodes On The Growth, Development, And Edible Quality Of Hydroponically Grown Lettuce (*Lactuca sativa* L. var. *capitata*)."*Scientia Horticulturae.* 150: 86-91.
- [18] Sivasangari A/P Jagatheeswaran. 2012, Assessing the quality of *Jatropha curcas* L. Seed As Planting Material In Sarawak. Transplanting In Red Leaf Lettuce. *HortSci* 45: 1809-1814.
- [19] Zhang YS, Huang X, Chen YF. 2009. Experimental course of plant physiology. Higher Education Press, Beijing (in Chinese).
- [20] Mckinney G. 1941. Absorption Of Light By Chlorophyll Solutions. *J Biol Chem.* 140: 315-322.