



**Mavrelou, Christoforos and Theotokatos, Gerasimos (2017) Modelling and parametric investigation of a large marine two-stroke dual fuel engine. In: The 11th International Symposium of Marine Engineering, 2017-10-15 - 2017-10-19. ,**

This version is available at <https://strathprints.strath.ac.uk/62276/>

**Strathprints** is designed to allow users to access the research output of the University of Strathclyde. Unless otherwise explicitly stated on the manuscript, Copyright © and Moral Rights for the papers on this site are retained by the individual authors and/or other copyright owners. Please check the manuscript for details of any other licences that may have been applied. You may not engage in further distribution of the material for any profitmaking activities or any commercial gain. You may freely distribute both the url (<https://strathprints.strath.ac.uk/>) and the content of this paper for research or private study, educational, or not-for-profit purposes without prior permission or charge.

Any correspondence concerning this service should be sent to the Strathprints administrator: [strathprints@strath.ac.uk](mailto:strathprints@strath.ac.uk)

# Modelling and Parametric Investigation of a Large Marine Two-Stroke Dual Fuel Engine

Christoforos Mavrelou\*, Gerasimos Theotokatos\*

\*Department of Naval Architecture, Ocean and Marine Engineering, University of Strathclyde,  
100 Montrose Street, Glasgow, G4 0LZ, Scotland, UK

This work deals with the modelling of a large marine two-stroke dual fuel engine of the low gas pressure concept by using the GT-Power™ software. Appropriate models were used to represent the engine processes including combustion, scavenging, heat transfer and friction whereas a knocking model was employed to characterise the engine unstable operation. The model was first validated against the manufacturer data and subsequently, the entire engine envelope in both operating modes was simulated. The derived results were used for analysing and discussing the engine performance and emissions as well as for comparing the two operating modes in terms of the turbocharger matching. In addition, parametric runs were performed and the results were used for identifying the settings that can further optimize the engine operation in the dual fuel mode in terms of CO<sub>2</sub> and NO<sub>x</sub> emissions trade-off.

Keywords: Marine two-stroke engines, simulation, dual fuel, premixed combustion, parametric investigation.

## 1. Introduction

As the environmental regulations have become more stringent, the marine dual fuel (DF) engines are attracting continuous interest from the shipping industry<sup>[1]</sup>. As a feasible solution, the marine engine manufacturers have developed DF versions of their engines operating in both diesel and DF modes.

Two different pathways have been followed by the major two-stroke engine manufacturers. These include the high-pressure direct injection of natural gas within the engine cylinders leading to the diffusive gas fuel combustion concept<sup>[2]</sup> and the low-pressure injection of the natural gas during the compression process resulting in a premixed combustion process<sup>[3-4]</sup>. In both cases, the investigation of the engine operation in both modes is expected to provide insights of the engine characteristics, performance and emissions as well as the turbocharger (T/C) matching, which has to accommodate the two different modes of operation.

Modelling techniques have been extensively used for analysing marine engines and ship propulsion systems. However, very few studies have been published focusing on marine DF engines

investigations. Examples of pertinent investigations dealing with the experimental and numerical analysis and settings optimisation for marine DF four-stroke engines as well as their control during fuel transitions were reported in <sup>[5-9]</sup>. However, a very limited number of studies for marine two-stroke DF engines has been presented so far.

In this respect, this work focuses on the investigation of a large two-stroke marine DF engine operating on the low-pressure concept. The engine model is set up in the GT-Power™ computational tool. Following the model validation, the engine operation in both modes and at various loads is investigated and the results are analysed for comparing the engine performance and emissions as well as discussing the turbocharger matching. Furthermore, parametric studies are carried out and the results are used to optimise the engine settings in DF operating mode.

## 2. Engine Modelling

### 2.1 Investigated Engine

In this work, the 5RT-flex50DF engine from WIN G&D<sup>[10]</sup> was investigated. This engine is a

camshaftless low-speed, two-stroke DF engine consisting of five cylinders connected in an in-line arrangement, one turbocharger unit and one air cooler unit. It employs a common rail diesel fuel injection system and gas injection at low pressure during each cylinder compression phase. The engine can operate in diesel mode by using heavy fuel oil or marine diesel/gas oil. In DF mode, natural gas is used as the main fuel while diesel fuel is utilized as pilot fuel in order to start the combustion process. When running in DF mode, the engine is fully compliant with the IMO Tier III NO<sub>x</sub> emission limits.

## 2.2 Model Set-up and Calibration

The GT-Power™ software<sup>[11]</sup>, which is a renowned OD/1D simulation program for engine modelling and analysis, was used. To set up the engine model, various components, and reference objects were selected and interconnected by using available connectors, so that the engine layout is represented in an adequate level.

Initially, the model for one-cylinder block was developed and validated both for the diesel and DF modes. Then the model was extended to cover the entire engine layout as shown in Fig. 1. The final engine model includes blocks for the cylinders, scavenging ports (SP), exhaust valves (EV), turbocharger (TC), air cooler (AC), auxiliary blower, waste gate (WG), exhaust pipes (EP) and receivers. Injector elements for the liquid (FI) and gas fuels (GI) as well as the pilot fuel (PI) are connected to each engine cylinder block.

To develop and calibrate the model for adequately predicting the engine performance and emission characteristics, various sets of input data were acquired and used. These included the engine geometry, the scavenging ports and exhaust valve profiles, the fuels injection timing, the compressor and turbine performance maps, the air cooler characteristics, the auxiliary blower characteristics and the waste gate valve geometry and measured parameters from engine trials.

For each model component, appropriate sub-models were selected and calibrated. For the engine cylinders, appropriate combustion, heat transfer, scavenging, friction, NO<sub>x</sub> emissions and knocking “sub-models” were identified and used.

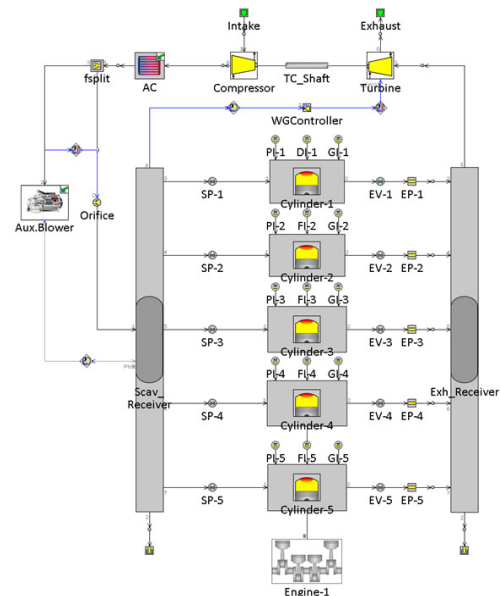

Fig.1 Engine model layout

The Woschni heat transfer model, calibrated for two-stroke engines, was used to calculate the in-cylinder gas to wall heat transfer coefficient, whilst a friction model was calibrated to adequately predict the friction mean effective pressure.

The combustion processes in the diesel and DF modes were modelled by using single or triple Wiebe functions, respectively. The three Wiebe functions correspond to the premixed pilot fuel combustion, the diffusive pilot fuel and the rapid burning of the gaseous fuel as well as the tail combustion of the cylinder contents<sup>[12]</sup>. The total fuel burning rate along with the fuels energy input is used for calculating the combustion heat release rate. The combustion model parameters were calibrated for 25%, 50%, 75% and 100% loads based on the pertinent information provided by the manufacturer.

The scavenging process was modelled by using a two-zone model which was set up by providing the relationship between the in-cylinder gas residual ratio and the residual ratio of the exhaust gas exiting the cylinder. As no data was available for approximating this relationship, it was estimated by modelling the diesel mode of one cylinder block by using an in-house simulation tool<sup>[13]</sup>.

To predict the NO<sub>x</sub> emissions, a two-zone (burned-unburned) model was used to represent the cylinder closed cycle and in this respect to calculate the burned zone temperature along with an extended Zeldovich mechanism<sup>[14]</sup>.

For evaluating the engine combustion stability, the Worret knocking criterion<sup>[11]</sup> was considered, according to which the probability of engine combustion to be characterised as stable or unstable is calculated. The model parameters were calibrated by modelling an engine operating point for which knocking was certainly expected, in specific by considering a retarded pilot injection timing resulting in start of combustion close to top dead centre. Subsequently, the calibrated model was used to characterize combustion in the investigated operating points.

In DF mode, the exhaust gas waste gate opening is controlled to adjust the combustion air to fuel equivalence ratio by regulating the scavenge air receiver pressure. By this means, combustion instabilities including knocking and misfiring are prevented. In addition, turbocharger overspeed at high engine loads can be avoided in diesel mode.

### 3. Results and Discussion

The engine operation under steady state conditions was examined by performing simulation runs in a load range from 25% to 100% of the maximum continuous rating (MCR) point. Constants calibration for the scavenging, knocking, NOx and AC heat transfer models was performed at the considered reference point of 75% load. Subsequently, the fine tuning of the model constants was carried out at this point for obtaining an adequate accuracy. The other investigated loads simulation and parametric runs were carried out by considering the models calibrated values of the reference point.

Table 1 Predictions percentage error

Engine Load (%MCR)	100	75	50	25
	Diesel mode – Error (%)			
Brake Power	-3.6%	-2.6%	-1.5%	-1.5%
Max. Pressure	-0.7%	-1.5%	-0.9%	-0.6%
Scav. Pressure	0.2%	1.3%	2.4%	0.6%
Exhaust Temp.	3.6%	3.2%	2.4%	2.6%
NOx	1.4%	0.06%	0.8%	1.4%
	Dual fuel mode – Error (%)			
Brake Power	-2.0%	-1.7%	-2.3%	-2.3%
Max. Pressure	1.0%	0.3%	1.5%	0.4%
Scav. Pressure	0.9%	0.9%	0.7%	0.4%
Exhaust Temp.	2.1%	1.8%	0.8%	2.2%
NOx	0.3%	-0.9%	0.8%	-1.5%

The percentage errors between the measured and predicted parameters are reported in Table 1. It can be inferred that the simulation results are of acceptable accuracy as the maximum error was around  $\pm 4\%$ . Therefore, the developed model can be considered a reliable tool for representing the engine steady state behaviour and hence, it can be used with fidelity for the engine parametric investigation.

A set of the derived simulation results including the engine performance parameters, NOx emissions, cylinder pressure and temperature diagrams as well as the compressor operating points on the compressor map is shown in Fig. 2. The engine power output and consequently the brake mean effective pressure (BMEP) were found to be similar in both diesel and DF modes. In the DF mode, the indicated mean effective pressure increases slightly due to the obtained higher in-cylinder pressures caused by the advanced start of combustion (as also inferred from the cylinder pressure and temperature diagrams), which is used in order to avoid knocking, and hence the friction mean effective pressure slightly increases.

Furthermore, both the turbocharger shaft speed and as a result the scavenge air receiver pressure are greater when the engine operates in diesel mode. This is owing to the opening of the waste gate bypass valve in the DF mode for controlling the combustion air-to-fuel ratio. However, the firing (maximum) pressure in the diesel mode is much lower (compared to maximum pressure obtained in the DF mode) as a result of the retarded start of combustion and the longer combustion duration.

From Fig. 2, it can be observed that the exhaust gas receiver temperature in the DF mode is greater (than the respective parameter in the diesel mode) for loads up to 75%, whereas it is less for loads above 75%. This is attributed to the fact that the exhaust gas receiver temperature is affected by the in-cylinder temperature at the exhaust valve opening (that is affected by the combustion heat release rate and air-fuel ratio) and the exhaust gas mass flow rate (influenced by the turbocharger speed and waste gate opening). In DF mode, the waste gate opening increases as the engine load reduces to match the targeted scavenge air receiver pressure, and as a result the air flow rate receives values lower than the respective ones in the diesel mode.

From the preceding, it can be inferred that the turbocharger performance characteristics will differ as the turbocharger speed, pressure ratio and flow rate are considerably reduced in the DF mode throughout the entire operating region due to the waste gate valve opening. In diesel mode, the operating point of the compressor is closer to the surging line when the engine operates at high engine loads close to 100%. However, the waste gate opening can prevent potential turbocharger overspeed. Despite the differences in the turbocharger components operation at the two engine operating modes, it can be concluded that the selected turbocharging unit effectively matches the engine as it provides sufficient air quantities with high efficiencies at all loads in both engine operating modes and provides sufficient surge margin.

The NO<sub>x</sub> emissions strongly depend (in fact, exponentially) on the in-cylinder temperature, pressure and trapped oxygen concentration, which are affected by the engine settings and the trapped air-fuel ratio. The maximum in-cylinder temperature and pressure values are greater in the DF mode; however due to the shorter combustion duration, the in-cylinder temperature and pressure reduce more rapidly compared to the diesel mode. This along with the DF lean premixed combustion implies that the NO<sub>x</sub> formation rate will effectively be less in the DF mode, compared to the diesel mode as also indicated from the results of Fig. 2.

Subsequently, a parametric study for optimising the engine settings in DF mode was performed with the aim of simultaneously reducing the NO<sub>x</sub> and CO<sub>2</sub> emissions. The latter are proportional to the engine brake specific energy consumption (BSEC) and inversely proportional to the engine brake efficiency. The following engine settings changes from their respective reference values were considered for each operating point and mode: pilot fuel injection timing (-3, 0 and +3 degrees CA), exhaust valve profile shift (-5, 0 and +5 degrees CA), scavenging air receiver pressure (-5%, 0% and +5%) and compression ratio (-5%, 0% and +5%). Consequently, 81 different parametric runs at each engine operating point were conducted. The combustion model considers a shift of the HRR (in each investigated load) according to the used injection timing whilst taking into account an

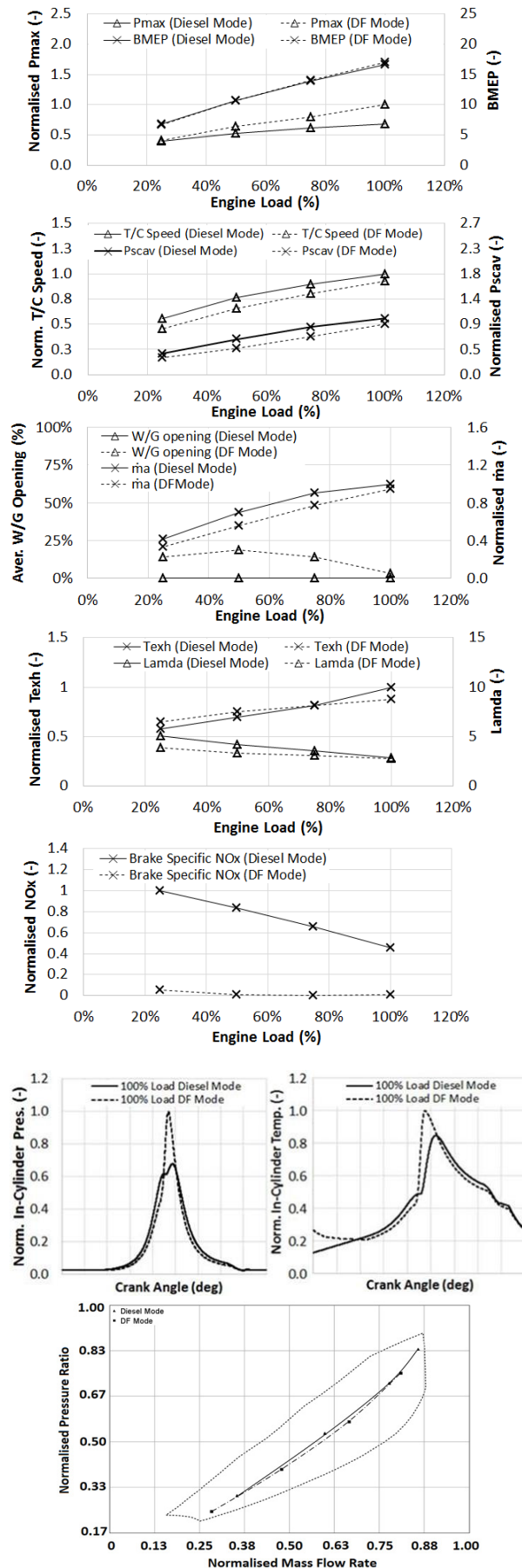

Fig.2 Simulation results at steady state conditions

appropriate ignition delay calculation. A subset of the derived results for the 75% load, which depicts the trade-off between the CO<sub>2</sub> and NO<sub>x</sub> emissions as well as the obtained cylinder maximum pressure along with its maximum permissible value, is depicted in Fig. 3. It was inferred that the greatest simultaneous reduction of CO<sub>2</sub> and NO<sub>x</sub> emissions is obtained for the reference value of the pilot fuel injection timing and therefore, it can be concluded that this parameter has been optimised by the engine manufacturer.

The exhaust valve profile retarding results in a longer expansion stroke and a shorter compression period leading to an increase of the brake power and the in-cylinder temperature; therefore, it marginally reduces the CO<sub>2</sub> emissions and slightly increases NO<sub>x</sub> emissions.

The boost pressure increase, which can be obtained by reducing the waste gate valve opening, results in greater turbocharger shaft speed and scavenging receiver pressure, which in consequence, provides more trapped air in the engine cylinders (leading to a leaner combustion) and a higher maximum pressure. As a result, both NO<sub>x</sub> and CO<sub>2</sub> emissions reduce at the expense of greater air-fuel ratio and maximum pressure; the former may result in combustion instability (knocking), whereas the latter can lead to greater engine cylinder components mechanical loading and wear or cylinder pressure above its permissible value.

The compression ratio increase results in greater maximum pressure and thus, in lower CO<sub>2</sub> (i.e. higher efficiency) and greater NO<sub>x</sub> emissions.

To derive the optimal engine settings, the estimated knocking probability as well as the maximum permissible cylinder pressure constraints was also taken into account as both knocking and the increased cylinder pressures can jeopardise the engine integrity. The maximum in-cylinder pressure value at 100% load was considered to be the permissible limit herein, as no information was provided with respect to the engine capability to withstand higher pressure values.

From the derived analysis it was found out that the optimisation of the 100% load is the more challenging as the maximum pressure exceeded in the majority of the investigated case the permissible value and the knocking probability was considerable.

However, these results are not presented herein due to the space limitation. In addition, engine operation at 100% load is not so frequent and therefore it was deemed that discussing the engine optimisation at 75% load is more essential.

In Fig. 3, four points with a favourable trade-off between CO<sub>2</sub> and NO<sub>x</sub> emissions were identified, the settings of which are presented in Table 2. These results indicate that adjusting the engine settings is a means of reducing the NO<sub>x</sub> and CO<sub>2</sub> emissions, whilst improving the engine brake efficiency. To select, however, the optimum settings, a compromise between the NO<sub>x</sub> and CO<sub>2</sub> emissions must be made. As the current engine is fully compliant with the IMO Tier III standards operating in DF mode, it is reasonable to assume that the final selection has to be in favour of reducing CO<sub>2</sub> emissions and consequently improving the engine efficiency. Therefore, point No. 4 is considered to provide a set of optimised settings at 75% load. By considering the other investigated engine load cases, the conducted parametric study indicated that simultaneous reduction of NO<sub>x</sub> and CO<sub>2</sub> emissions in the region of 1.5–4.8% can be obtained.

Table 2 Potential optimum settings for 75% load

Engine Settings			
No.	$\Delta EV$ (°CA)	$\Delta p_{scav}$ (%)	$\Delta \epsilon$ (%)
N/A			
1	0	5	0
2	5	5	0
3	0	5	5
4	5	5	5

Results					
No.	$\Delta NO_x$ (%)	$\Delta CO_2$ (%)	$\Delta P_b$ (%)	$\Delta p_{max}$ (%)	P(k)
N/A					
1	-7.17	-0.29	0.31	2.55	0
2	-6.79	-0.80	0.81	0.19	0
3	-2.93	-1.28	1.32	7.90	5
4	-1.38	-1.69	1.69	4.95	0

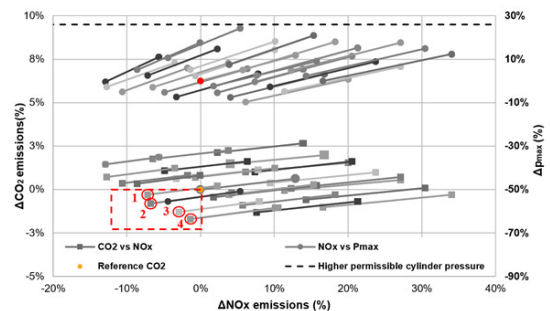

Fig.3 Parametric study results for 75% load

## 4. Conclusions

In the present study, a marine two-stroke DF engine was simulated in the GT-Power™ software to investigate its performance and emission characteristics in both diesel and DF mode as well as to further optimise the engine settings in terms of NO<sub>x</sub> and CO<sub>2</sub> emissions trade-off by conducting parametric runs. The main findings of this study are summarised as follows. The simulated results exhibited sufficient accuracy ( $\pm 4\%$  max. error), thus ensuring the fidelity of the developed 0D/1D engine model. The results analysis provided insights for the engine behaviour in both operating modes and revealed that the engine-turbocharger matching, although challenging, satisfies both operating modes. Finally, the parametric study results revealed that a simultaneous further reduction of NO<sub>x</sub> and CO<sub>2</sub> emissions can be obtained via appropriate selection of the engine settings.

However, an engine optimisation experimental verification is necessary to select the final engine settings. In this respect, the present study provides the basis for the engine optimisation and the results contributed to the better understanding of the interplay between engine settings and performance-emissions parameters.

## Acknowledgments

We would like to deeply thank Messrs. A. Kyrtatos, A. Tomazos, and G. Volkmar of WIN G&D for their trust, support and input, which made this work feasible. GT support is also greatly acknowledged.

## References

- [1] S. Adams, "LNG as ship fuel", The Future – Today, pp. 6-7, (2014)
- [2] S. Kindt and O. Sørensen, "MAN B&W Two-stroke Engines Latest design development within engine types", CIMAC Congress, (2016)
- [3] I. Nylund and M. Ott, "Development of a Dual Fuel technology for slow-speed engines", CIMAC Congress, (2013)
- [4] M. Spahni, A. Kyrtatos and R. D. Jong, "The New X Generation Low-Speed Engines from Wärtsilä", CIMAC Congress, (2013)

- [5] I. Nylund, "Field Experience with the Wartsila 50DF Dual-Fuel Engine", CIMAC Congress, (2007)
- [6] N. Boeckhoff, G. Heider and P. Hagl, "Operational experience of the 51/60 DF from MAN Diesel", CIMAC Congress, (2010)
- [7] H. Mohr and T. Baufeld, "Improvement of Dual-Fuel-Engine Technology for Current & Future Applications", CIMAC Congress, (2013)
- [8] E. J. Sixel, J. Hiltner and Rickert, C., "Use of 1-D simulation tools with a physical combustion model for the development of Diesel-Gas or DF engines", CIMAC Congress, (2016)
- [9] R. Ishibashi, D. Tsuru, "An optical investigation of combustion process of a direct high-pressure injection of natural gas", J Mar Sci Technol, DOI 10.1007/s00773-016-0422-x, (2016)
- [10] Winterthur Gas & Diesel, "5RT-flex50DF Engine Operation Manual", (2015)
- [11] Gamma Technologies, "GT-SUITE Manual", (2016)
- [12] G.A. Karim, "Dual-Fuel engines", CRC Press, Taylor & Francis Group, (2015)
- [13] C. Guan, G. Theotokatos, H. Chen, "Analysis of two stroke marine diesel engine operation including turbocharger cut-out by using a zero-dimensional model", Energies, 8(6), 5738-5764, (2015)
- [14] G.P. Merker, C. Schwarz, G. Stiesch, and F. Otto, "Simulating Combustion", Springer, (2006)

## Nomenclature

$CA$	: Crank angle [degrees]
$\dot{m}$	: Mass flow rate[kg/s]
$p$	: pressure [bar]
$P$	: Power [kW]
$P(k)$	: probability of knocking [%]
$T$	: Temperature [K]
$\Delta$	: Change [-]
$\varepsilon$	: Compression Ratio [-]
subscript	
$a$	: air
$b$	: brake
$exh$	: exhaust gas
$max$	: maximum
$scav$	: scavenging