



**Reguera Castillo, Luis and Roscoe, Andrew (2017) Experimental stability assessment of converter-dominated electrical grids. In: 16th Wind Integration Workshop, 2017-10-25 - 2017-10-27. ,**

This version is available at <https://strathprints.strath.ac.uk/62229/>

**Strathprints** is designed to allow users to access the research output of the University of Strathclyde. Unless otherwise explicitly stated on the manuscript, Copyright © and Moral Rights for the papers on this site are retained by the individual authors and/or other copyright owners. Please check the manuscript for details of any other licences that may have been applied. You may not engage in further distribution of the material for any profitmaking activities or any commercial gain. You may freely distribute both the url (<https://strathprints.strath.ac.uk/>) and the content of this paper for research or private study, educational, or not-for-profit purposes without prior permission or charge.

Any correspondence concerning this service should be sent to the Strathprints administrator: [strathprints@strath.ac.uk](mailto:strathprints@strath.ac.uk)

# Experimental Stability Assessment of Converter-Dominated Electrical Grids

Luis Reguera Castillo, *Member, IEEE*, and Dr. Andrew Roscoe, *Senior Member, IEEE*

**Abstract**—With the increased deployment of renewable energy devices into power systems, more converters controlled by the standard D-Q axis Current Injection (DQCI) theory have been connected to the grid, displacing synchronous generators in the process. Due to the nature of the DQCI strategy, these converters cannot impose a reference voltage and frequency. A study in the simulation environment has been done in [7] where it is shown that, for a certain limit of DQCI converters connected to the grid (or level of penetration of converters), system-wide stability can be compromised. This work presents an experimental equivalent study. It is shown that the main contributor to the system stability and the level of penetration for DQCI-controlled converters is not the active power injected by synchronous generators, but the nominal power of the generators. An alternative converter control strategy which transforms the converter into a real voltage source of energy is tested experimentally on this paper; it is shown that the use of a combination of both algorithms in large electrical grids can provide a robust grid based purely on converters.

**Index Terms**—grid building converter, microgrid, VSM, voltage source converters, 100% converter-based grid.

## I. INTRODUCTION

WITH the growth of renewable generation into the electrical grid, fossil fuel plants are being replaced mainly by wind, tidal and solar generators. This change inherently represents a progression in the dynamics of the electric system, moving from a synchronous generator-based to a converter-based network, where both systems have to work together in a stable manner. With the increasing number of D-Q axis Current Injection (DQCI) converters installed, stability problems have progressively arisen and countries with a high level of converter-penetration - such as Ireland[1], UK[2] and Spain[3] - have begun to face the technical difficulties that entails high percentages of converter interfaced generation such as; loss of inertia, increase of the Rate of Change of Frequency (RoCoF), etc. However, these are just symptoms of a system based more and more in power sources that do not contribute much to the grid stability.

The DQCI strategy weaknesses are mainly two: First, it needs a Phase-Locked-Loop (PLL) system to get the synchronization with the grid. Since the PLL uses the measured voltages to provide the necessary time reference for the converter it can not impose a reference of angle, it only can follow it. Thus, it cannot contribute to the angle stability; Second weakness of the DQCI control is caused by its main variable of control, the output current. Thanks to the standard vectorial control, the active ( $P_{ref}$ ) and reactive ( $Q_{ref}$ ) power injected on the grid are controlled using the voltage measured at the Point of Common Coupling (PCC). Once  $P_{ref}$  and  $Q_{ref}$  are controlled, outer loops can be created to control the

PCC voltage [5] [6]. Since this control has been designed in cascade, it is evident that, effectively, outer loops will have to use the inner one to set their references. As result, regardless of the outer loops, the main control reference is always the output current and, therefore, converters controlled with this strategy have a similar behavior to a current source with limited voltage regulation capability. In combination, both weaknesses make DQCI converters not able to contribute enough to the angle nor voltage stability.

If there is only a minimum proportion of DQCI converters into the energy mix, stability problems are negligible since the remaining generators can compensate regulating more the grid angle and the voltage magnitude to balance the system. Naturally, this leads to the following question: how much power can be dispatched through DQCI-controlled converters before system stability is compromised? An attempt to answer this question is presented in [7] using a simple power system comprising a synchronous generator and a DQCI-controlled converter. However, as the authors note, the limit depends on large number of parameters including (but not limited to) the nominal power of the grid elements, the regulators gains which set the converter dynamics and the transmission line characteristics (such as impedance). To overcome stability issues, a solution involving the creation of what is called ‘grid-forming nodes’ was developed [8]. These nodes are voltage sources at strategic points of the network that can guarantee the pursued voltage stiffness whilst the converters in the vicinity can follow it to inject the energy produced into the grid in a proper manner. It was shown that the presence of these nodes into the system allowed greater penetration of converter-connected generation than would be possible with only DQCI-controlled converters. Nonetheless, these results were confined to simulations only.

### A. Alternatives to the standard DQCI control

There are several alternative control algorithms which take inspiration from the principles of operation of a synchronous machine, some more so than others. The so-called VISMA control algorithm (developed in [9]) controls the output current using as core logic the well known swing equation. In [10], the algorithm is refined such that it behaves as a voltage source. The performance of VISMA under islanding scenarios was assessed in [11].

A solution termed as ‘Synchronverter’ was presented in [12] and [13]; in this controller, a full mathematical model of a synchronous generator is implemented as the control logic for the converter. That is, internal variables featured include

virtual fluxes, virtual torques, virtual damping windings etc. Accordingly, the controller's objective is to mimic exactly the behavior of a synchronous machine. Consequently, the converter adopts the disadvantages of a synchronous machine in addition the advantages.

Zhang et al in [14]-[16] proposes only emulating the principle of synchronization found in synchronous machines; that is, synchronization is achieved through power flow considerations. Accordingly, the control system was termed 'Power Synchronization Control'. Through this approach, there is no need for the PLL. However, although robust, this solution still lacks on transforming the converter into a source of robust positive sequence voltage.

Finally, the last technique to review in this paper is the so-called Virtual Synchronous Machine Zero Inertia (VSM0H), explained in [17], and chosen for the assessment in this paper. This control strategy provides a true voltage source to the grid by imposing the magnitude and angle of the converter's driving voltage. Using droop controllers and boxcar filters, this technique controls the active power through the driving voltage angle whilst, on the other side, the reactive power is controlled by the driving voltage magnitude. The main advantage of the VSM0H algorithm is the simple but effective operation in terms of performance against challenging scenarios [7][17][18] without using any PLL for synchronization.

In this paper, a representative scenario of a converter-dominated grid is assessed, moving the work previously done in simulation to the lab. The standard DQCI algorithm and the chosen VSM0H technique will be object of analysis in a converter dominated grid, including its feasibility and a power quality analysis. The definition of the maximum power installed in a grid based on converters or level of penetration will be discussed including a explanation about its different definitions. Finally, a maximum level of penetration will be obtained for both algorithms proving the suitability of each one of them depending on the grid scenario.

### B. Definition of level of penetration

The level of penetration is a key parameter within converter-dominated electrical grids. It tries to encapsulate the idea of how much demand is being fed with converters connected to the grid allowing a robust and feasible operation. However, as it will be shown later, this idea can be difficult to express in a single parameter since the particularities of big interconnected grid can be too many to be condensed in a single number. Thus, several definitions of this parameter will be explained as following.

The most straightforward definition of this parameter can be obtained dividing the total power installed in the system in two groups, one for all the generators based on converter systems and another for the ones based on synchronous generators. If the power of each group is combined, it is possible to find a percentage or  $LoP$ . This is explained in equation (1):

$$LoP(\%) = \frac{\sum |P_{Conv}|}{\sum |P_{Conv}| + \sum P_{SG}} \quad (1)$$

where  $P_{Conv}$  is the total active power provided by converters installed in the system,  $P_{SG}$  is the total active power

provided by synchronous generators or generators not-based in converters.

However, this research topic involves the study of large power systems, much more intricate and complicated than the ones studied and simplified here. Such systems have many particularities in a electric market that evolve to, each time more, larger and more interconnected systems that exchange energy using high power rated connections. Although these connections can be done also in AC, usually they are done in DC due to its higher transmission capacity [19]. Thus, a formula that would take into account this particularity can be expressed as follows:

$$LoP_{exp}(\%) = \frac{\sum P_{Conv} + HVDC_{Imports}}{Demand + HVDC_{Exports}} \quad (2)$$

where  $P_{Conv}$  is the power injected based in converters,  $HVDC_{Imports}$  is the contribution of power generation from external systems,  $HVDC_{Exports}$  is the power exported to another systems and  $Demand$  is the total demand of the system, in watts, regardless of the energy origin necessary to provide it.

On the other side, as the grid progresses towards a converter dominated system, it is more obvious the need of nodal references in the system that solve the local instability due to absence of voltage regulation. Thus, due to the shortage of synchronous generators (or voltage sources in simpler point of view), systems where the primary source of power will be based on converters will need stiff sources of voltage, also called grid-building nodes. Hence, in a future scenario where converter systems will be the primary source of energy, the level of penetration can be redefined as a parameter to quantize the total power of systems that impose a reference of voltage and angle compared to the ones that do not. (3) encapsulates this information.

$$LoP_{dqCI}(\%) = \frac{\sum P_{DQCI}}{\sum P_{DQCI} + \sum S_{SG} + \sum S_{GBN}} \quad (3)$$

where  $P_{DQCI}$  is the aggregated active power injected or removed from the system such as; energy storage devices or HVDC systems but always based on DQCI converters,  $S_{SG}$  is the aggregated nominal power connected into the system based on real synchronous systems, and  $S_{GBN}$  is the aggregated rated power of all the grid building converters whether it is based on the VSM0H technology or any algorithm that are connected to the grid.

For the context of this paper, (1) is the most consistent and coherent formula. However, from a holistic point of view, this definition may not comprehend all the information. Hence, the three definitions will be used on the ongoing experiments to show the differences between them.

## II. EXPERIMENTAL SETUP

The system to be assessed is presented in Fig. 1. It represents a schematic of a converter-dominated network. It consists of a synchronous generator of 2.2 kVA which represents the aggregate of the remaining synchronous generation, a loadbank of 10 kW, and a tailor made converter of 10 kVA

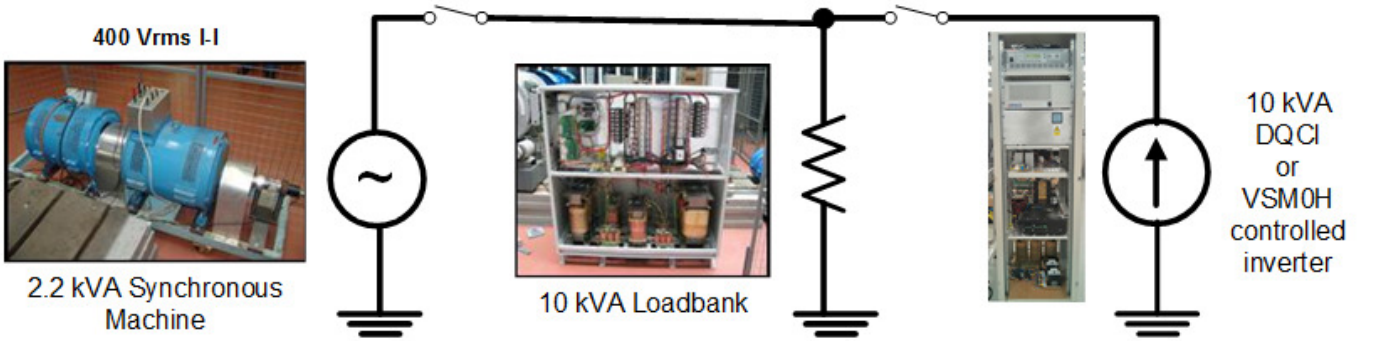

Fig. 1: Schematic diagram of the assessed system

representing the aggregate of the converter-connected generation. As it can be seen, the power rating of the converter system is much higher than the synchronous set.

This synchronous machine allows the injection of power, grid-connected or islanding, but it needs to be switched off and on again to change between operation modes. The control logic of the converter can be completely changed maintaining all the hardware installed on it thanks to the dSPACE box built inside of it.

Regarding to the data extraction, all the signals referring to the converter and the load are taken from tailor-made boards based on LEM sensors connected to the dSPACE box. Thus, the signals are sampled at the same frequency as the control logic (5kHz). However, the signals referred to the synchronous set are taken from current and voltage transducers connected along the microgrid to an external computer that processes all the measurements. These signals are sampled at 1500 Hz but then they are filtered and down-sampled to 500 Hz.

### III. EXPERIMENTS

Two experiments have been conducted during this paper comparing the performance against different events of the standard DQCI algorithm and the VSM0H technique.

#### A. Level of Penetration experiment

It is straightforward to think that, if a DQCI converter needs an external voltage to obtain a synchronization reference, there must be a minimum of energy coming from traditional generators, needed in the system, in order to allow a stable injection of power from the converters. However, as it will be demonstrated later in this experiment, it is the nominal power of the regulating devices what can potentially compromise the system stability. This experiment explores which is the maximum power dispatched from converters controlled with the standard DQCI or VSM0H control strategy, if there is any limit, reducing the number of variables to the minimum.

The process done to produce the results is as follows. First, the synchronous set is started in islanded mode building its own voltage and frequency. Then, the loadbank is connected with a load of approximately 700 W. The synchronous set satisfies this demand easily since it is significantly lower than the 2.2 kVA that can produce. Following, the converter is connected to both systems and it is commanded to inject 500

W. This liberates the synchronous set and now it only has to inject 200 W of power to satisfy the total load of 700 W. Then, the demand is increased to 1200 W. Automatically, the synchronous set reacts, injecting a total of 700 W whilst the converter remains injecting 500 W. Later, a new step in the converter active power reference is executed injecting a total of 1000 W. This, again liberates the synchronous set from injecting power and the process is continued until the system becomes unstable, or the maximum load has been reached in the loadbank.

The process explained before has been done for the two algorithms studied on this paper, one where the converter was controlled using the standard DQCI control, and another where the VSM0H was used. Fig. 2 is an excerpt of the steady state conditions obtained on this scenario. As it can be extracted from the results, both control strategies have reached the maximum level of power on the loadbank with stable conditions. Here, the same signals are shown for the two cases, DQCI on the left and VSM0H on the right. From top to bottom, it is represented the voltage for every phase ( $V_{abc}$ ), its Total Harmonic Distortion (THD) in percentage, the imbalance between phases in percentage, and the total contribution of each generator to the load of approximately 10 kW,  $P_{gen}$  for the synchronous set and  $P_{conv}$  for the converter.

As it can be observed, in both cases, the converter is contributing in almost its totality, to the load supply. Both scenarios represent a stable grid where the power quality has not affected to the load; THD lower than 5% and the unbalance between phases less than 3% in both cases. These conditions would fulfill the most common grid codes in Europe (see [20] as example).

Applying the equations explained in section I-B, the table I shows the levels of penetration obtained for the different equations.

Level of Penetration obtained			
	$LoP$	$LoP_{exp}$	$LoP_{dqcl}$
DQCI	97 %	97 %	81.6 %
VSM0H	99.3%	99.3%	0 %

TABLE I: Results obtained using (1-3)

Since there is no HVDC on this experiment,  $LoP$  and  $LoP_{exp}$  provide identical results. Both formulas obtain a result

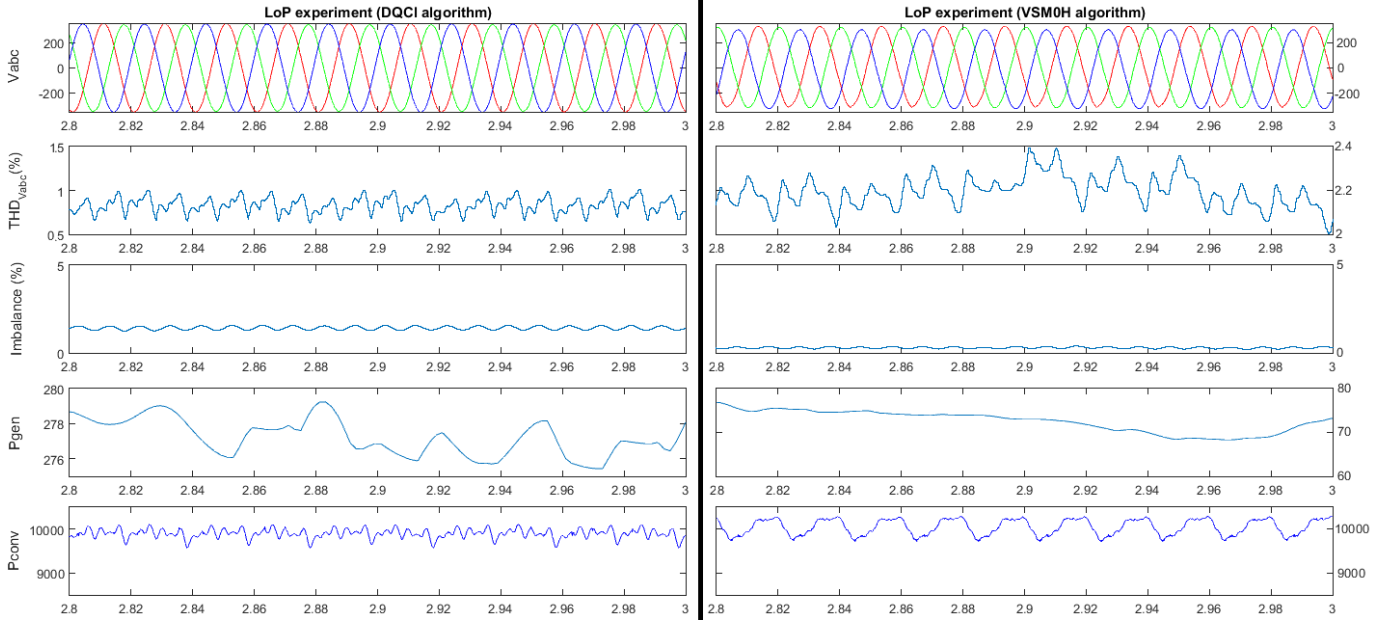

Fig. 2: Level of Penetration experiment

very close to 100% without affecting to the power quality at the load. This means that, in order to get a stable system, the active power generation is not the main contributor to the stability of the system; it is the natural regulation capability of the synchronous generator which, imposing a voltage and a frequency reference, provides the stability to the system. Furthermore, if the converter is capable of imposing a voltage and frequency in the same manner as synchronous machine do, converters could be directly replaced by synchronous machines without affecting to the stability nor the power quality of the system, and allowing the possibility of a true 100% converter-based system.

Consequently, a correct definition of level of penetration has to take into account, not the active power injection from the synchronous generator, but the regulation capability of the machines, i.e. the nominal power of the machine connected. This is better encapsulated in the definition of  $LoP_{dqcl}$  which reduces the level of penetration to 81%. However, this formula gives an inconsistent value of 0% for the VSMOH since there is no DQCI generation at that point.

In order to test the cited dependence of the nominal power of the synchronous generation to the stability, a new experiment is conducted where the synchronous set is disconnected from the system for both algorithms.

### B. Lost of mains experiment

The results from this experiment are shown in Fig. 3 for both algorithms. The scenario is the same as the one explained in the previous experiment. From top to bottom the following signals are plotted: the load voltage ( $V_{abc}$ ), the currents supplied by the converter ( $I_{abc_{conv}}$ ), the currents supplied by the synchronous generator ( $I_{abc_{gen}}$ ), the active power supplied from the converter and generator ( $P_{conv}$  and  $P_{gen}$ ) drawn in dark and light blue respectively, and finally the frequency obtained from the converter PLL.

For the DQCI algorithm (signals on the left), the experiment begins with both generators (converter and generator) connected to the microgrid, and feeding in conjunction a load of approximately 3.5 kW; 3 kW supplied by the converter and only 0.5 kW by the synchronous generator. At approximately 7.3 sec the synchronous set is disconnected from the system leaving the converter isolated with the load. Initially, the converter reacts properly and, after an initial overshoot in  $P_{conv}$  the reference remains to the previous value before the fault. However, as it was mentioned before, it is only the converter the one that is producing the voltage signal at the load. Thus, the converter is producing and measuring the grid voltage in order to obtain its own synchronization reference. Eventually, this creates a great uncertainty in the resultant effect since, the outcome of the control logic (the voltage created by the converter) is also the input of the system (the PLL needs this signal to create the synchronization reference necessary to drive the converter). This uncertainty gives as result a fast random increase or decrease of the grid frequency. For the case plotted here, from the moment when synchronous generators disconnects, frequency continues decreasing until approximately 7.7 sec. When the frequency goes lower than 45 Hz, the protection by underfrequency enters into action disconnecting the converter from the system.

It is worth remarking that the event can not be fixed if droop slopes are added to the control logic. If so, against the drop in frequency, the converter would react injecting more active power executing primary regulation. However, from the moment the synchronous generator is disconnected of the system, it is only the converter and the load the ones that remain in the grid. Therefore, the power synchronization mechanism which underpins the primary regulation is not valid anymore and an increase in  $P_{conv}$  would only provoke an increment of the converter output current, increasing with it the load voltage. The opposite effect can be observable on



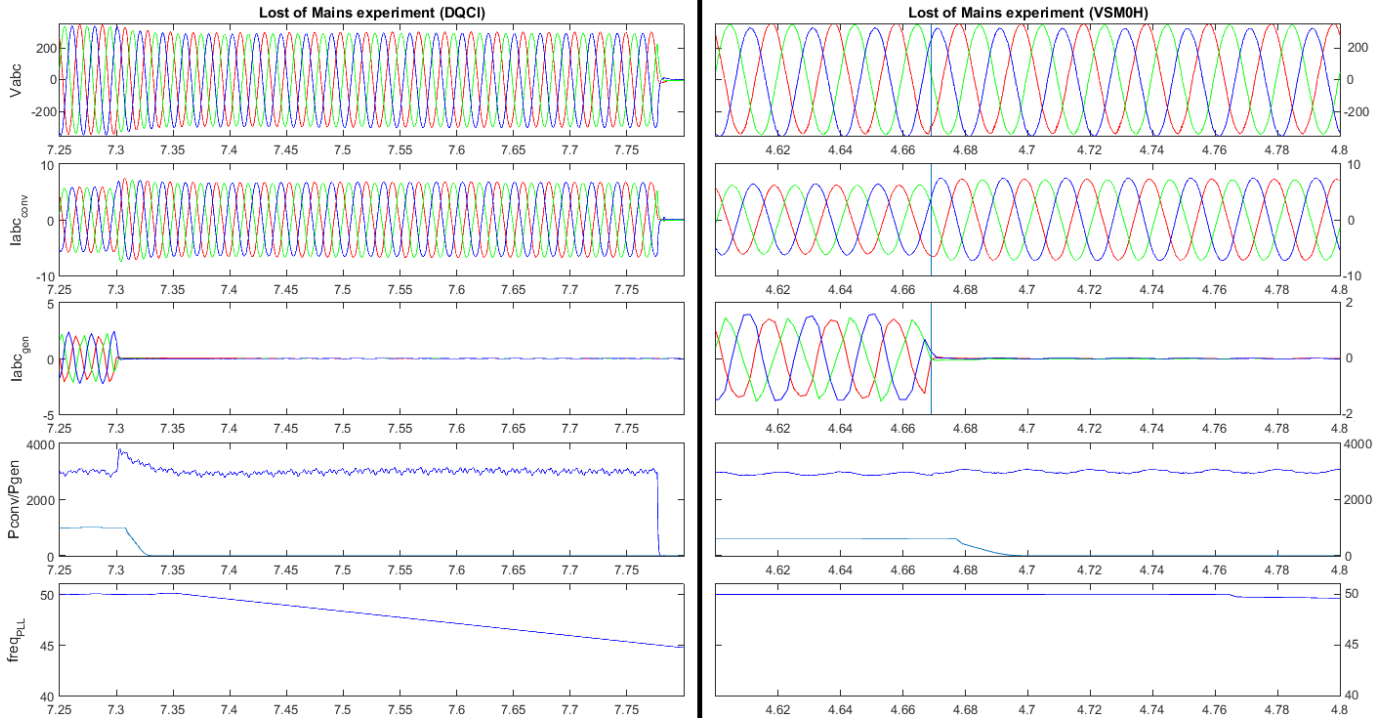

Fig. 3: Lost of Mains experiment

the load voltage when the synchronous generator disconnects. From that moment, the voltage reduces slightly due to the absence of synchronous generator current.

With similar conditions the experiment is repeated for the VSM0H algorithm. Here, at approximately 4.67 sec, the generator disconnects, letting the converter isolated. In this case, since VSM0H is also a voltage source, it can impose a reference of voltage and frequency, and when the machine disconnects, only an almost unnoticeable oscillation is observed on the load voltage (a thin blue line has been plotted to be observed in detail). Moreover, now, in order to maintain the voltage between its terminals, the converter reacts naturally increasing the output current and providing the one previously supplied by the synchronous generator.

It is important to remark that from the moment the converter is the only generator and is able to supply the load, the system is being fed by exclusively converter systems, achieving with it a true and feasible  $LoP$  of 100%. The power quality has not been affected and the differences of voltage pre and post-fault are almost none, proving that a converter controlled with VSM0H can build its own grid if it is necessary.

The DQCI experiment has proved that the regulating capability of the synchronous generators is necessary in grids where converters are controlled exclusively by the DQCI strategy. On the other hand, the VSM0H experiment has proved that converters controlled with this strategy, or any other that makes the inverter to behave as a real voltage source, can replace entirely synchronous machines in terms of regulation capabilities.

### C. Discussion

From the results obtained in the first experiment it can be observed that an almost 100 % converter-based production can be achieved with the standard DQCI algorithm as well as with VSM0H. However, from the second experiment can be observed that some synchronous generation has to be always connected to impose a reference of frequency and voltage. From the first experiment it also can be extracted that the stability and the power quality of the grid remains unaffected by the lack of active power generated by the synchronous machine. Therefore, there is no connection between the active power generated by synchronous machines and the level of penetration limits nor the limit when the power quality at the load is compromised. It is the nominal power of the machines connected to the grid what provides this limit, since this will indicate how much capability the grid has to compensate diversions of voltage and frequency out of the nominal values. Thus, a correct definition of level of penetration must take into account, not the active power generated by synchronous generators ( $P_{gen}$ ), but the nominal power of the machines connected to the grid ( $S_{gen}$ ) whether they are actually injecting power or not.

However, converters controlled using algorithms such as VSM0H can provide these regulation capabilities and this is so due to the fact that they behave as true voltage sources which can impose a reference of voltage and frequency in the same manner as synchronous generators do.

Regarding to the Level of Penetration definition, it seems that for the case analyzed on this paper the definition  $LoP$  and  $LoP_{exp}$  are the most consistent but they do not take into account the cited dependence between the nominal power gen-

erated by synchronous generation and the level of penetration. On the other hand, although for this particular case the formula  $LoP_{dqcl}$  provides wrong results for the grid building node algorithms (see table I for VSMOH), it does envelope the cited dependence. A new formula which collects the cited relation and combines the previous ones is presented here:

$$LoP(\%) = \frac{\sum |P_{DQCI}| + \sum |P_{GBN}|}{\sum |P_{DQCI}| + \sum S_{SG} + \sum S_{GBN}} \quad (4)$$

Eq (4) adds a new term  $P_{GBN}$  on the numerator since, although these systems regulate as synchronous machines do, physically, they are converter-connected generation too. Also, incorporating the absolute value of the active power terms, HVDC systems which import or export energy can be added on the terms  $P_{DQCI}$  or  $P_{GBN}$ , depending how these systems are controlled. This formula provides consistent results of level of penetration for large or small systems taking into account the particularities of large interconnected grids.

#### IV. CONCLUSION

A representative experiment of a converter-dominated network has been built in a microgrid. A new definition of level of penetration which takes into account the particularities of a large interconnected system has been defined.

It also has been proven that there is no dependence between the active power generation provided by synchronous machines and the level of penetration, it is the nominal power of the machines connected what really affects into this parameter and limits the amount of converter generation connected to the grid. It also has been proven that this regulating machines can be completely replaced by converters which behave as voltage sources, such as VSMOH, without affecting to the stability nor the power quality of the load, opening the possibility to large interconnected systems based fully on converters.

#### REFERENCES

[1] EirGrid: 'DS3 Enhanced Performance Monitoring : Frequency Transient Analysis', EirGrid, 2013.

[2] National Grid: 'Frequency Changes during Large Disturbances and their Impact on the Total System', National Grid, Proposal for consultation, 2013.

[3] Spanish Electricity System 2016 Report - Summary. Red elctrica de Espaa, 2016.

[4] P. Kundur et al., "Definition and classification of power system stability IEEE/CIGRE joint task force on stability terms and definitions," in IEEE Transactions on Power Systems, vol. 19, no. 3, pp. 1387-1401, Aug. 2004.

[5] Remus Teodorescu; Marco Liserre; Pedro Rodriguez, "Grid Converter Structures for Wind Turbine Systems," in Grid Converters for Photovoltaic and Wind Power Systems , 1, Wiley-IEEE Press, 2011, pp.123-143

[6] Amirnaser Yazdani; Reza Iravani, "Controlled-Frequency VSC System," in Voltage-Sourced Converters in Power Systems:Modeling, Control, and Applications , 1, Wiley-IEEE Press, 2010, pp.541

[7] M. Yu, A. J. Roscoe, A. Dyko, C. D. Booth, R. Ierna, et al., "Instantaneous Penetration Level Limits of Non-Synchronous Generation in the British Power System," IET Renewable Power Generation, 2016.

[8] R. Ierna, J. Zhu, H. Urdal, A.J. Roscoe, M. Yu, et al., "Effects of VSM Converter Control on Penetration Limits of Non-Synchronous Generation in the GB Power System," 15th Wind Integration Workshop, At Vienna, Austria.

[9] H. P. Beck and R. Hesse, "Virtual synchronous machine," 2007 9th International Conference on Electrical Power Quality and Utilisation, Barcelona, 2007, pp. 1-6.

[10] Y. Chen, R. Hesse, D. Turschner and H. P. Beck, "Comparison of methods for implementing virtual synchronous machine on inverters," 2012 International Conference on Renewable Energies and Power Quality (ICREPQ), Santiago de Compostela, 2012.

[11] Y. Chen, R. Hesse, D. Turschner and H. P. Beck, "Investigation of the Virtual Synchronous Machine in the island mode," 2012 3rd IEEE PES Innovative Smart Grid Technologies Europe (ISGT Europe), Berlin, 2012, pp. 1-6.

[12] Q. C. Zhong and G. Weiss, "Synchronverters: Inverters That Mimic Synchronous Generators," in IEEE Transactions on Industrial Electronics, vol. 58, no. 4, pp. 1259-1267, April 2011.

[13] Q. C. Zhong, G. C. Konstantopoulos, B. Ren, and M. Krstic, "Improved Synchronverters with Bounded Frequency and Voltage for Smart Grid Integration," IEEE Transactions on Smart Grid, 2016.

[14] L. D. Zhang, L. Harnefors, and H. P. Nee, "Power-Synchronization Control of Grid-Connected Voltage-Source Converters," IEEE Transactions on Power Systems, vol. 25, pp. 809-820, May 2010

[15] L. D. Zhang, L. Harnefors, and H. P. Nee, "Modeling and Control of VSC-HVDC links connected to island systems" IEEE Transactions on Power Systems. May 2011

[16] L. D. Zhang, L. Harnefors, and H. P. Nee, "Interconnection of Two very weak AC Systems by VSC-HVDC Links Using Power-Synchronization Control" IEEE Transactions on Power Systems, vol. 26, February 2011

[17] M. Yu et al., "Use of an inertia-less Virtual Synchronous Machine within future power networks with high penetrations of converters," 2016 Power Systems Computation Conference (PSCC), Genoa, 2016, pp. 1-7.

[18] A.J. Roscoe et al, "A VSM (Virtual Synchronous Machine) Converter Control Model Suitable for RMS Studies for Resolving System Operator / Owner Challenges" 2016 15th Wind Integration Workshop, Vienna, Austria

[19] Thomas Ackermann. Wind Power in Power Systems. 2nd edition. Wiley 2012. Chapter 22. pp. 480-508

[20] National Grid codes: <http://www2.nationalgrid.com/uk/industry-information/electricity-codes/grid-code/the-grid-code/> (accessed Aug 2017)

#### APPENDIX: PARAMETERS OF THE SYSTEM

2.2 kVA Generator Parameters	
Line-Line Voltage	400 V
Frequency	50Hz
Speed	1500 rpm
Xd	1.836 pu
Xd'	0.09 pu
Xd''	0.01 pu
Xq	0.7016 pu
Xq''	0.01
Coefficient of inertia	0.9
Pole Pairs	2
Stator Resistance	0.01244 pu
Friction Factor	0.02742 pu
Converter Parameters	
DC power source	600V, 25A
Nominal power of the converter	10kVA
Input Resistance for DC bus discharging	10 kΩ
Input Capacitor	2.2 μF
IGBT's $I_{rms,max}, V_{ce,max}$	25A, 1200V
Main inductor filter	3 mH
Capacitor filter	8.8 μF
LC Resonance frequency damping resistor	22 Ω
Antiwindup resistor	100 Ω
Output Transformer (Connected after the converter filter)	230 / 400 Vrms 1-1 10KVA Delta-Star connected
Sampling and logic frequency	5 kHz
PI regulators for output current loop (DQCI)	3.706 + 872.1/s
PI regulators for DC currents removal block (VSMOH algorithm)	0.08845 + 1.07/s
Loadbank parameters	
Maximum active power	9728 W
Maximum power factor	± 0.8