

Development of a test method for assessing laceration injury risk of individual cleats during game-relevant loading conditions

OUDSHOORN, Bodil <<http://orcid.org/0000-0001-5081-4078>>, DRISCOLL, Heather, DUNN, Marcus <<http://orcid.org/0000-0003-3368-8131>>, SENIOR, Terry <<http://orcid.org/0000-0002-3049-5724>> and JAMES, David <<http://orcid.org/0000-0002-1135-626X>>

Available from Sheffield Hallam University Research Archive (SHURA) at:

<http://shura.shu.ac.uk/17444/>

This document is the author deposited version. You are advised to consult the publisher's version if you wish to cite from it.

Published version

OUDSHOORN, Bodil, DRISCOLL, Heather, DUNN, Marcus, SENIOR, Terry and JAMES, David (2017). Development of a test method for assessing laceration injury risk of individual cleats during game-relevant loading conditions. *Footwear Science*, 10 (1), 1-10.

Copyright and re-use policy

See <http://shura.shu.ac.uk/information.html>

Development of a test method for assessing laceration injury risk of individual cleats during game-relevant loading conditions

Professional rugby union players experience an injury once every 10 matches, and up to 23% of these injuries are skin lacerations. Current regulations to assess laceration injury risk of cleated footwear involve two optional mechanical tests for manufacturers; a drop test and a pendulum test. However, there is limited rationale for these tests and associated impact parameters. A questionnaire among 191 rugby players showed that the ruck is the most prevalent game scenario in which skin laceration injuries occur. During the ruck, laceration injuries result from stamping movements by players wearing cleated footwear. A biomechanical study was conducted to obtain game-relevant impact parameters of stamping in the ruck. Eight participants were asked to perform ten stamps on an anthropomorphic test device. Kinetic and kinematic data were clustered – identifying two distinct phases of the stamp motion – providing test parameters for mechanical assessment of skin laceration risk. A two-phase mechanical test was designed to quantify laceration injury risk of individual cleats. Phase one represents initial impact and phase two represents the subsequent raking motion as observed in the biomechanical study. Each phase is based on the impact parameters of observed stamping impacts. The developed test method has the potential to be adapted as an international standard for assessing laceration injury risk of cleated footwear. Future research is required to assess the repeatability of this method and its sensitivity to laceration injury.

Keywords: biomechanics, rugby, impact testing, mechanical testing, injury risk

1. Introduction

In field sports, cleats are worn to increase traction on the field. Cleated footwear has previously been associated with metatarsal injuries (Ford et al., 2006; Queen et al., 2008) and anterior cruciate ligament (ACL) injuries (Lehner, Dießl, Chang, & Senner, 2013; Twomey, Connell, Petrass, & Otago, 2013). However, Hall & Riou (2004) cited several severe laceration injuries which were thought to be caused by cleated footwear. In 2008, a cleated footwear manufacturer was sued by a soccer player after he sustained

a laceration to the head, blaming the cleat design for the severity of his injury (Dennehy, 2008). A recent study surveying 191 rugby union players found that 71% of players had experienced at least one substantial laceration injury (defined as hindering play and / or leaving the pitch) caused by cleats during their rugby career (Oudshoorn, Driscoll, Dunn, & James, 2016a). Overall, approximately 5% of the injuries in rugby union are lacerations or skin injuries (Oudshoorn, Driscoll, Kilner, Dunn, & James, 2017a). This is similar to association football, where lacerations account for 4% of all injuries sustained during a game (van den Eijnde, Peppelman, Lamers, van de Kerkhof, & van Erp, 2014). Laceration injuries sustained by players frequently require stitching and expose players to risk of infections (Gibbs, 1993; van den Eijnde et al., 2014).

Traction is dependent on the ground surface as well as the soleplate of the shoe; sports played on different surfaces will require different outsole designs to attain optimal traction. Generally, softer surfaces should be played with longer cleats compared to harder surfaces. In rugby union natural grass is the dominant playing surface, but artificial turf is also allowed under Regulation 22 (World Rugby, 2015b) and its use is becoming increasingly common. Both surfaces allow cleat penetration. Traditionally, shoes in rugby union are equipped with rounded aluminum screw-in cleats. Bladed cleats were introduced in 1994 and are commonly made out of a single plastic molded sole plate; the elongated profile of blades gives rise to their name. Figure 1 shows a variety of cleat shapes that are commonly used in rugby union, depending on playing position requirements, pitch conditions and personal preference (Oudshoorn et al., 2016a).

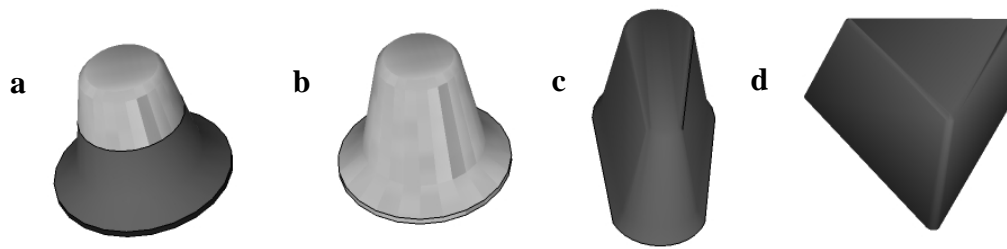

Figure 1: Different cleat designs commonly used in rugby; (a) combined material rounded cleat, (b) aluminum rounded cleat, (c) bladed cleat, and (d) triangular cleat.

Cleat regulations in field sports are implemented to control the cleat's laceration injury risk. In American football, the American Football League proscribes a minimum diameter for bladed and conical cleat shapes (Goodell, 2015); however, the regulation does not require manufacturers to assess laceration risk through a mechanical test. The Fédération Internationale de Football Association (FIFA), governing body of association football, currently does not regulate what type of cleats are worn. Footwear checks performed by the referee prior to the match should identify 'dangerous' cleats. FIFA's regulations do not mention any mechanical test method to assess the laceration injury risk of cleated footwear, though laceration injuries occur with a similar frequency to rugby union (van den Eijnde et al., 2014). An overarching regulation for field sports using similar footwear is desirable.

In rugby union, the design of cleats is regulated by the sport's international governing body, World Rugby (Dublin, Ireland). In World Rugby's clothing and footwear regulations (World Rugby, 2015a), two performance tests are described to assess the laceration injury risk of individual cleats. Although published in World Rugby's regulations, these tests are currently optional for manufacturers. The test parameters have not been validated to replicate injurious scenarios of rugby play. The first laceration risk test, Test A, aims to replicate skin raking or glancing of the cleat

(Figure 2). Test A describes a single cleat attached to the end of a pendulum arm, being raked over a skin simulant; however, neither impact mass nor impact velocity is specified. The second laceration risk test, Test B, aims to replicate a stamping movement by a vertical impact of the cleat into a skin and deformable muscle simulant (Figure 2); impact mass and drop height are defined within Test B. Both Test A and Test B require a skin simulant to assess cleat damage. Human skin is loading rate dependent (Chanda & Unnikrishnan, 2016), meaning that with a constant impact energy, varying impact velocity and mass will influence the material response. Therefore, game-representative impact conditions during mechanical tests are essential when analyzing damage to skin simulants caused by cleats.

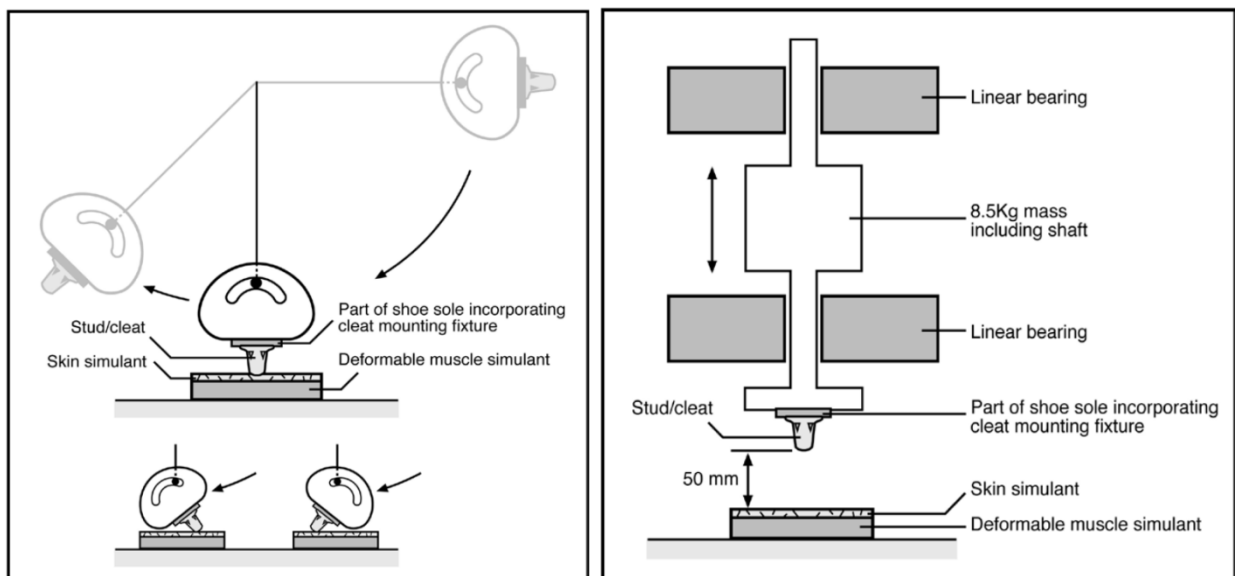

Figure 2: Test A (left) and Test B (right) for cleated footwear, as described in World Rugby's Regulation 12 (World Rugby, 2015a). Image reprinted with permission from World Rugby.

Mechanisms of the target injury, such as injury loads, must be well understood when developing mechanical tests for sports equipment (McIntosh, 2012; Odenwald, 2006). To date, no research has been published on the biomechanics of cleat-skin

interaction in rugby union. Stamping in the ruck has previously been identified as the most common game scenario causing laceration injuries resulting from cleat-skin interactions in rugby union (Oudshoorn et al., 2016a). Stamping in the ruck is a purposeful movement where a player brings their foot heavily down onto an opponent lying on the floor. The kinetics and kinematics of this movement must be identified to inform the design of a representative cleat-skin interaction test.

Previously, biomechanical information has been used to inform the development of mechanical test devices. Grund, Senner, & Gruber (2007) developed a test method to assess non-contact ACL injury risk under game-relevant loading conditions by converting broadcast footage of ACL injuries in a three-dimensional human segment model. Due to the non-contact nature of the injuries and knowledge on body measures of the injured player, estimates could be made on cleat-turf traction forces. Stamping in the ruck is a movement where foot contact is often obscured from the camera view by surrounding players; furthermore, force estimates are limited by player-to-player interactions during the impact. Therefore broadcast footage cannot be used to obtain biomechanical information on stamping during the ruck. Although less representable than a field study, lab-based biomechanical studies allow for measurement of foot kinetics and kinematics. Clarke, Carre, Damm, & Dixon (2013) developed a test method to investigate shoe-surface traction in tennis courts using ground reaction forces obtained during a laboratory-based biomechanical study. The study showed that complex dynamic changes occur during shoe-surface contact, and direct measurements of both kinetic and kinematic data was fundamental for developing a mechanical test with relevant loading conditions.

The purpose of this research was to identify appropriate impact parameters for a test method to assess the laceration injury risk associated with individual cleats, and to translate these parameters into a representative, cost-effective and realistic design.

2. Design requirements

2.1 Acquiring impact parameters

To inform design requirements of a mechanical test to assess laceration injury risk of cleats, the kinetics and kinematics of stamping during the ruck was investigated. For this study, eight participants (mean \pm standard deviation (SD): age: 27.1 ± 4.4 years; stature: 174.1 ± 5.1 cm; mass: 76.2 ± 8.2 kg) were recruited; all procedures were approved by the Health and Wellbeing Ethics committee of Sheffield Hallam University. Participants were asked to form a one-versus-one rucking formation and perform ten stamps on an anthropomorphic test device (ATD, Hybrid III, 50th percentile male, Humanetics Innovative Solutions, Plymouth, USA) used as a surrogate player (Figure 3).



Figure 3: Two participants in a one-on-one rucking formation with the participant performing a trial.

Two time-synchronized high speed (100 Hz) cameras (Phantom Miro Lab 320, Vision Research, Wayne, USA) were used to obtain three-dimensional motion kinematics of the foot. Inbound velocity of the foot (\vec{v}_i , direction and magnitude) was calculated for each trial. Cleat angle θ (Figure 4) was calculated following a previously described method (Driscoll, Kirk, Holmes, Koerger, & Haake, 2009). More details on this study design and the analysis of the initial impact phase was previously published (Oudshoorn, Driscoll, Dunn, & James, 2017b). Subsequent raking velocity (\vec{v}_r) was calculated for selected trials. Two pressure sensors (sample rate 750 Hz, Tekscan, F-scan, 3000E 'Sport') were used to measure pressure between cleats and the ATD. Following a custom calibration method (Oudshoorn, Driscoll, Dunn, & James, 2016b), pressure values were converted to force (N).

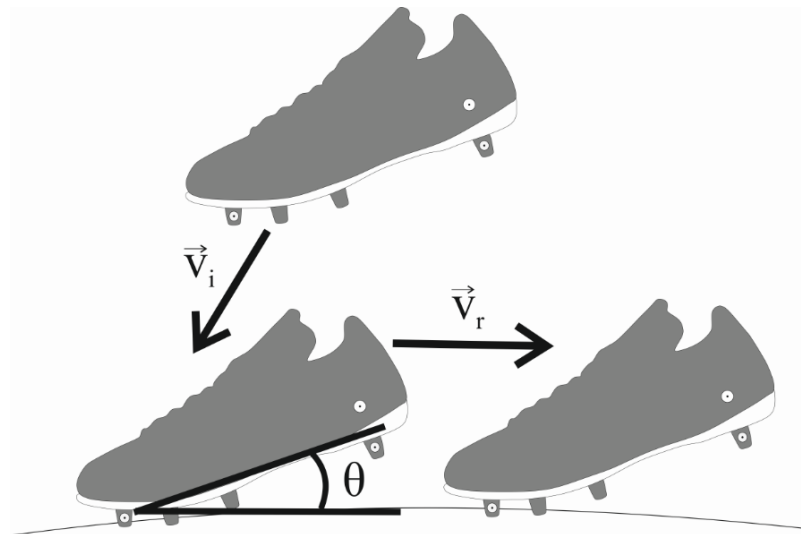

Figure 4: Movement of the foot during stamping in the ruck, with \vec{v}_i as inbound velocity of the foot, \vec{v}_r as raking velocity of the foot and θ as cleat angle.

2.2. Phase one: initial impact

The stamping impacts that were observed during the biomechanical study could be split into two phases; an initial impact phase and a subsequent raking motion phase. Four

impact parameters from the initial impact phase were calculated that influence the test device's design; impact mass, inbound velocity magnitude, inbound velocity angle, and cleat orientation angle. The effective mass of the impact (m_i) is derived from cleat force over time (Fdt) by using Equation (1) (adapted from Neto, Silva, Marzullo, Bolander, & Bir, 2012):

$$m_i = \frac{\int_{t_1}^{t_2} F dt}{\Delta v} \quad (1)$$

With t_1 being time at first impact; t_2 time at which foot velocity is reaches approximately 0, and Δv the foot velocity difference between t_0 and t_1 . Impact energy of each stamp was calculated using impact mass and inbound velocity. Inbound foot velocity of all trials (mean \pm SD) was $4.3 \pm 1.2 \text{ m s}^{-1}$ oriented at $44^\circ \pm 15.3^\circ$ to the global vertical. Peak individual cleat force was $221 \pm 59 \text{ N}$. Data of all eight participants were clustered based on impact energy. Four clusters with varying combinations of test parameters were identified (Table 1). Each cluster characterizes different movement solutions.

Table 1: Results of rugby stamping impacts, organized into four clusters (mean \pm SD of 20 stamps). Each cluster represents a different movement approach, used as a set of impacts parameters of the developed test method.

Cluster	Impact mass	Inbound velocity	Inbound velocity angle	Cleat angle	Resulting impact energy
A	$1.5 \pm 0.6 \text{ kg}$	$2.9 \pm 0.5 \text{ m s}^{-1}$	$29 \pm 13^\circ$	$7 \pm 12^\circ$	6.3 J
B	$0.8 \pm 0.2 \text{ kg}$	$4.8 \pm 0.5 \text{ m s}^{-1}$	$48 \pm 13^\circ$	$18 \pm 11^\circ$	9.2 J
C	$1.7 \pm 0.5 \text{ kg}$	$3.7 \pm 0.8 \text{ m s}^{-1}$	$45 \pm 13^\circ$	$11 \pm 16^\circ$	11.6 J
D	$0.9 \pm 0.3 \text{ kg}$	$5.4 \pm 0.7 \text{ m s}^{-1}$	$54 \pm 10^\circ$	$2 \pm 8^\circ$	13.1 J

2.3. Phase two: raking motion

In 53% of all trials, a raking motion was observed after initial foot impact. To identify test parameters from the raking motion for the second phase of the test method, a representative trial was selected. Identification of the representative trial was based on cleat force data (all trials), filtered with a 4th order bi-directional Butterworth filter (cut-off frequency: 50Hz) and time-synchronized based on a force threshold (30 N). The initial impact phase was defined as the first 47 ms post impact, and raking phase as the following 82 ms. The mean of all time-synchronized trials during the raking phase was calculated. A trial with mean cleat force during raking phase closest to mean cleat force during raking of all trials was chosen as the representative trial. Mean (\pm SD) cleat force of all trials during the raking phase was 137.6 ± 39.0 N; mean cleat force of participant 4, trial 9 was 136.8 ± 13.5 N. Figure 5 shows the force transient of the selected trial.

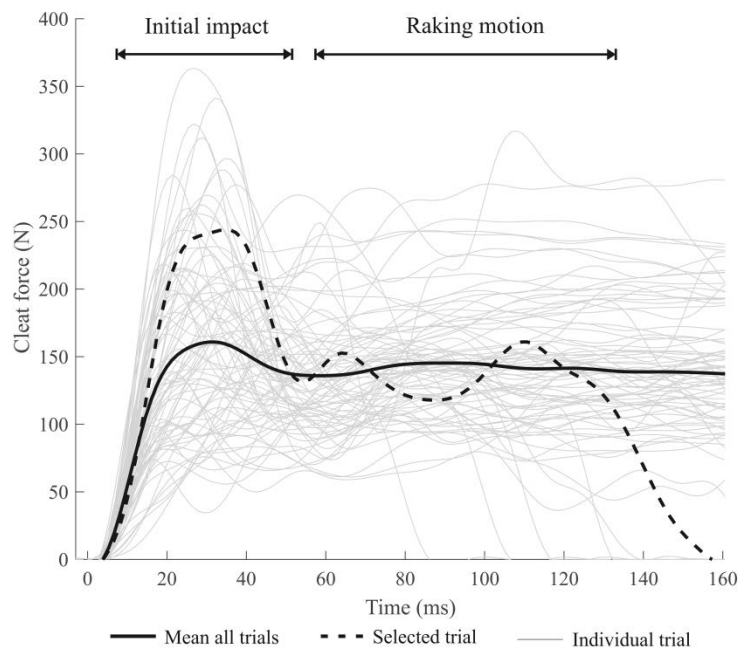

Figure 5: Selection of a representative trial. Average raking phase of selected trial (136.8 ± 13.5 N) is similar to average of all raking phases (137.6 ± 39.0 N).

The foot markers of the representative trial were manually identified from high speed video footage for 166 frames after first impact, giving a velocity trace for 166 ms. At the end of the raking phase ($t = 129$ ms), a horizontal foot velocity of 0.93 m s^{-1} was reached. The vertical velocity stayed approximately zero after initial impact. Foot displacement during the raking phase was 52 mm.

2.4. Test device demands and constraints

The developed test method must produce a quantifiable measure of laceration injury risk for individual cleats, resulting from game-relevant loading conditions. In order for the test method to be adapted as an international standard, it must be unambiguous and relatively simple such that third parties can build their own version of the test device. Build costs for the test device should be minimized as to make it more accessible to a larger number of test houses and research centers. To implement the test method as an international standard, the outcome measures need to be clear and easy to interpret. The test method should be able to provide pass and fail criteria such as described in World Rugby's current regulations for cleated footwear (World Rugby, 2015a). The biomechanics of cleat laceration injuries in other sports - such as soccer and American football - have not yet been investigated; therefore the test device should be suitably adaptable to simulate the variety of test parameters as required by different sports. This adaptability will be paramount in developing an overarching laceration risk regulation for sports using cleated footwear.

3. Mechanical test design

3.1. Test one: initial impact

Replicating the initial impact phase of stamping motions requires a combination of

independently changeable settings from the test device (Table 1). Various designs were explored to comply with the required flexibility of settings whilst maintaining a simple, repeatable test device. A sliding impactor was causing high friction on its bearings, therefore limiting the inbound velocity it could produce. A vertical drop hammer with a changeable, inclined impact surface caused large off-axis loading on the drop hammer and this limited the lifespan of the test device. The proposed pendulum design (Figure 6) can set the required impact parameters (Table 1) independently. The circular bearings reduce friction compared to a sliding impactor and avoid the off-axis loading of a drop hammer. The design has four adjustable settings;

- (1) Impact mass, adjusted by weights (0.2 kg intervals, range: 0.8 to 2.0 kg)
- (2) Inbound velocity, adjusted by release height (range: 0 to 5.4 m s⁻¹)
- (3) Inbound velocity angle, adjusted by changing the pivot point (three options: 30°, 45° and 60°)
- (4) Cleat angle, adjusted by cleat attachment (5° intervals, range -10° to 30°)

After each impact, the skin simulant tray will be removed from the first test and moved to the second test.

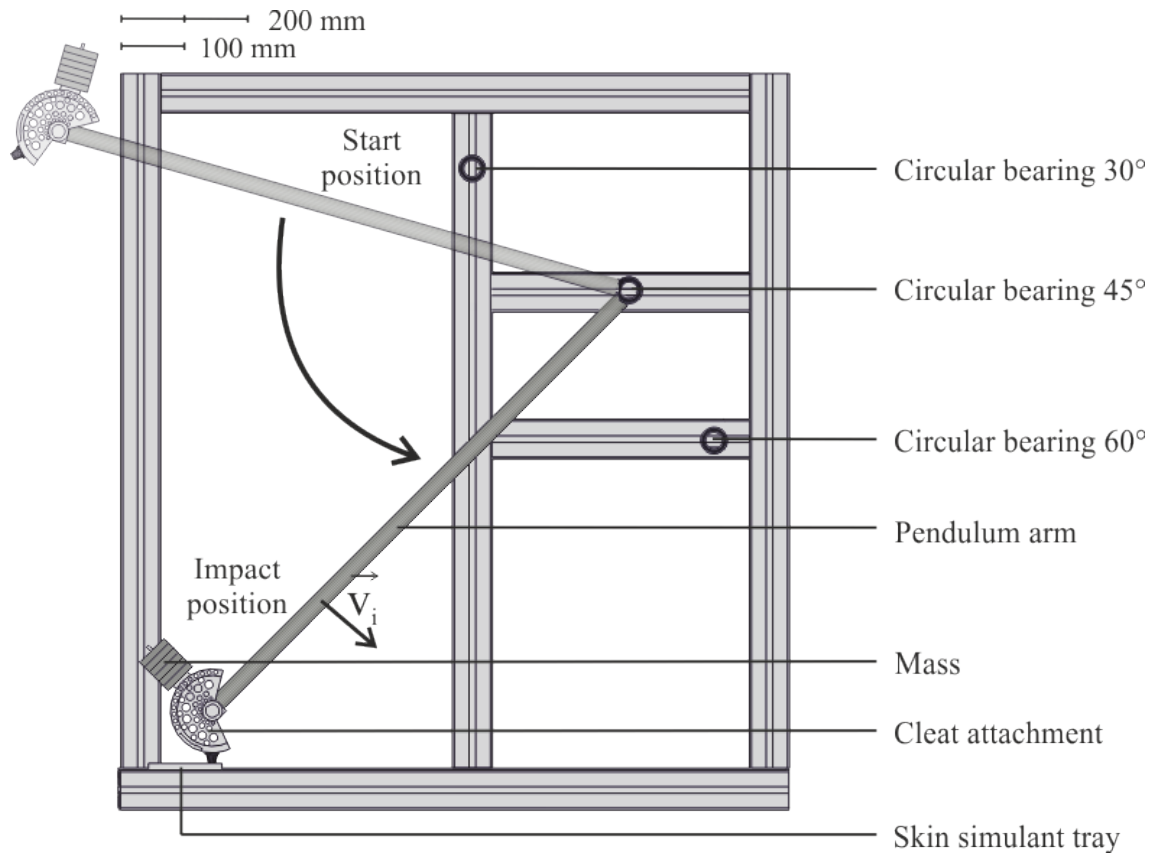

Figure 6: Schematic of test device design for phase one.

3.2. Test two: raking motion

Analysis of the representative trial showed that mean cleat force during the raking phase is 137 N. This force was exerted whilst accelerating from 0 to 0.93 m s^{-1} and raking a distance of 52 mm. The second test phase replicates the cleat force and velocity profile of the representative trial as defined in section 2.3. For exerting a cleat force of 137 N, a system where a cleat presses on the skin simulant through the use of pushing weights (14.0 kg) attached to linear bearings was developed (Figure 7).

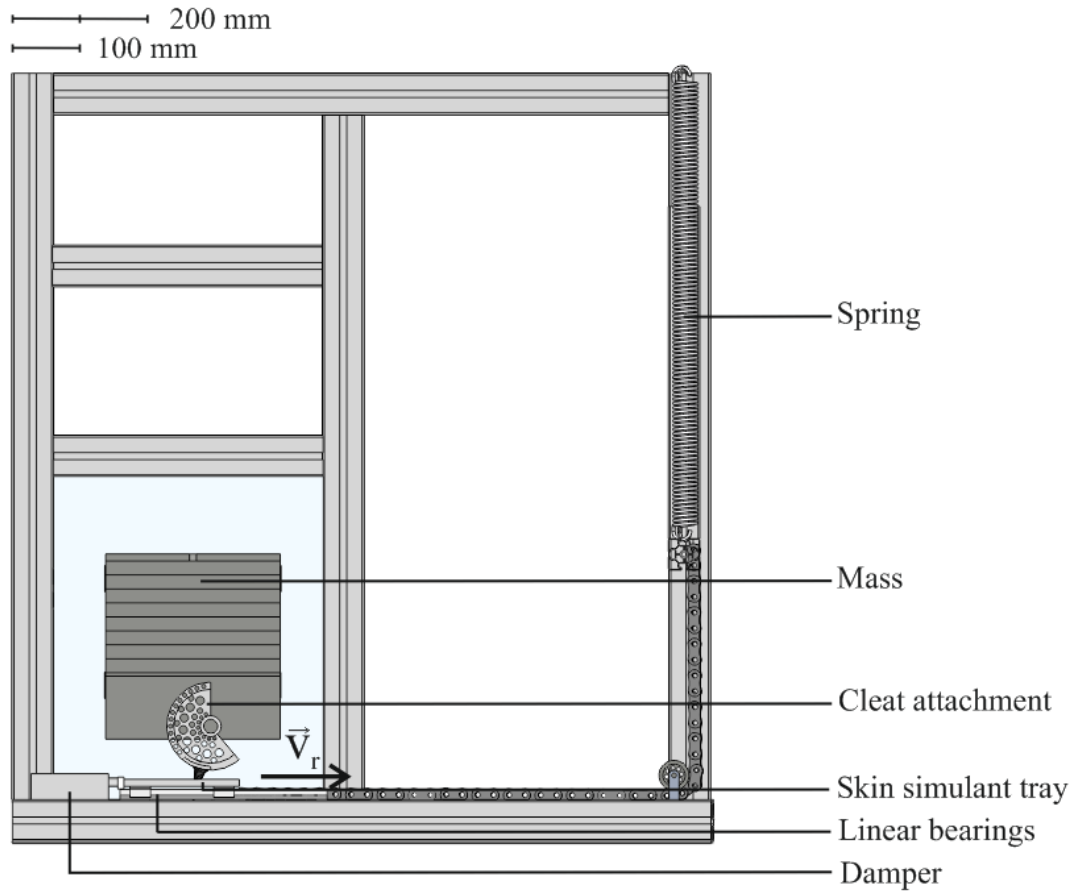

Figure 7: Schematic of test device design for phase two.

Motorized, gravity driven and spring-damper system design solutions were considered to move the skin simulant tray in a way that matches the raking velocity profile. In the final design, a spring-damper solution was used, balancing associated costs with flexibility of the design and consistency across test devices. In the raking test device, the skin simulant and its tray can slide over low friction bearings. The proposed test device design accelerates the skin simulant tray rather than the cleat. To achieve this, a spring-damper system is put under tension, and when released the skin simulant tray moves in the direction shown (Figure 7). In the representative trial, end velocity of

the raking phase (v_{re}) was 0.93 m s^{-1} ; this velocity was reached after 52 mm raking distance (Δx). This means that the raking time of the test (Δt) would be (Equation 2);

$$\Delta t = \frac{\frac{v_{re} - v_{r0}}{2}}{\Delta x} \quad (2)$$

With v_{r0} being starting velocity of skin simulant tray ($v_{r0} = 0 \text{ m s}^{-1}$), giving $\Delta t = 0.11 \text{ s}$.

The acceleration (a_{sim}) of the simulant tray which is subsequently needed in the raking test device is defined by (Equation 3);

$$a_{sim} = \frac{v_{re} - v_{r0}}{\Delta t} \quad (3)$$

Where a_{sim} is 8.3 m s^{-2} with $\Delta t = 0.11 \text{ s}$. The pushing weights, cleat attachment and cleat together weigh 14 kg; replicating the mean cleat force (137 N) during the raking phase.

This normal load (F_n) will cause a frictional force between the cleat and skin simulant.

The expected friction force (F_f) between cleat-simulant interfaces is dependent on choosing a skin simulant with an appropriate friction coefficient. The coefficient of friction (c_f) between two materials can be calculated using Equation (4);

$$c_f = \frac{F_f}{F_n} \quad (4)$$

The dynamic coefficient of friction of human skin to aluminum rounded tip skin is 0.42 ± 0.14 (mean \pm SD) (Zhang & Mak, 1999). With 137 N normal load and dynamic friction coefficient 0.42, expected friction force during the raking phase is 57 N (Equation 4). When ignoring friction in the system, the springs need to pull with at least 57 N to accelerate the simulant tray during the raking phase. The proposed raking test device design can vary cleat angle similar to the initial impact pendulum design.

3.3 Interpretation of results

Each simulant in the test method is used for one test repeat. A three-dimensional (3D) optical scanning system (Artec Space Spider, Artec 3D, Luxembourg, Luxembourg) with point accuracy of up to 0.05 mm and resolution of up to 1.5 mm is used to provide a baseline and post-impact scan of each skin simulant (Figure 8). The skin simulants are impacted and raked with both mechanical tests before they are analyzed. Skin simulant damage of an individual cleat is measured by determining laceration wound volume, defined as the difference between baseline and post-impact scan of each skin simulant, reported in mm³. Secondary geometric measures such as laceration surface area, laceration perimeter, laceration length (defined as longest axis along laceration edges) and laceration width (defined as longest axis perpendicular to laceration length axis) are also obtained.

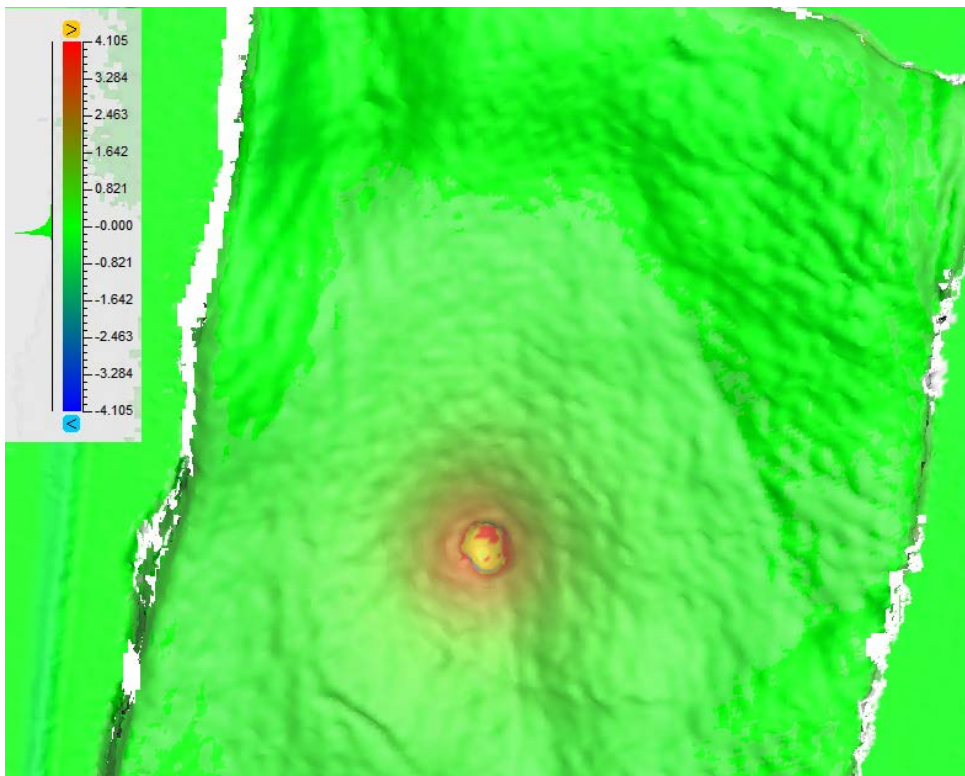

Figure 8: Example of a difference map created from a baseline and post-impact 3D scan of a skin simulant.

4. Discussion

This study set out to identify impact parameters for a test method assessing laceration injury risk associated with individual cleats, and to translate these parameters into a representative, cost-effective and realistic design. A biomechanical investigation of rugby stamping impacts showed that participants employed different movement solutions. Four impact parameter clusters were identified and used to develop the first test device, which replicates the initial impact phase of a stamping in the ruck. A representative trial was selected to inform the design of the second test device, replicating the raking phase of stamping impacts. Together these two test devices and form a new test method to assess the laceration injury risk of cleated footwear under game-relevant loading conditions.

The current cleated footwear tests, published in the World Rugby regulations (World Rugby, 2015a), have previously been found unrepresentative of impacts causing laceration injuries during a rugby game (Oudshoorn et al., 2017b). This study showed that Test B in the current regulations has an impact energy of 4.2 J, which is 2.1 J lower than the lowest impact energy in phase one of our proposed test method and 8.9 J lower than its highest impact energy. The proposed test method has a lower impact mass (0.8 - 2.0 kg) than current regulations proscribe (8.5 kg). Its higher impact energy results from larger inbound velocities in the proposed test method (2.9 - 5.4 m s⁻¹) compared to the current test (1.0 m s⁻¹). No comparisons could be made between the proposed test method and Test A in World Rugby's regulations, since inbound velocity and impact mass are not defined for Test A. Mechanical test devices allow for comparison of results measured at different times and places, therefore making them suitable to be implemented as part of regulations or standards (Odenwald, 2006). World Rugby's current test methods for assessing laceration injury risk of cleated footwear has not been

based on biomechanically acquired parameters, though previous research has shown this is of importance when developing mechanical tests (Clarke et al., 2013; McIntosh, 2012; Odenwald, 2006).

A number of limitations should be recognized when interpreting the results of this research. Although the developed test method aims to replicate stamping impacts as closely as possible, replicating the full range of dynamic changes in actual biomechanical impacts is a tremendous task (Clarke et al., 2013). Therefore, a clustering approach and a selected trial were used to obtain impact parameters informing the test designs. Further, the validity and repeatability of the proposed test method is influenced by the skin simulant used in conjunction with the test. To date, synthetic skin simulant materials which are affordable and fully replicate the mechanical behavior of human skin (e.g. frictional properties, breaking loads, hardness shore) are difficult to obtain. Biological simulants such as porcine skin are commonly used for their relative similarity to human skin (Falland-Cheung, Pittar, Tong, & Waddell, 2015). Porcine skin is easy to obtain and affordable; but using biological simulants can be unhygienic, the tissue degrades quickly and it is highly variable. The developed test method replicates real-world rugby laceration injury scenarios as closely as possible. Nevertheless, the results of this test method should be interpreted using a 'comparator cleat', as previously described in Regulation 12 (World Rugby, 2015a), since the outcome measure cannot be interpreted as an absolute prediction of wound size.

Future studies are needed to identify the most suitable skin simulant to use and to investigate the skin injury threshold levels associated with the new test method. The outcome measure of the developed test method is currently based on wound size (area, volume). Classifying each wound in accordance with a skin tear classification system

such as STAR (Carville et al., 2007) could prove useful for the interpretation of the test results and should be considered in future research. The developed test method has the potential to be adapted as an international standard for assessing laceration injury risk of cleats in rugby union. The test method has integrated adaptability for a wider range of impact parameters than were needed to replicate rugby stamping impacts.

Biomechanical parameters of cleat laceration injury scenarios in other sports (e.g. association football, American football) still need to be investigated. With modifications, the test method could be adopted across field sports where laceration injury risk of cleats is of importance.

5. Conclusion

In this research, a test method was developed which assesses the laceration injury risk of individual cleats. Game-relevant loading conditions of laceration injury scenarios needed to be obtained to inform the test method. Kinetics and kinematics of eight participants stamping in a rucking scenario were investigated. A two-phase test approach was developed based on the observed stamping impacts; an initial impact phase where velocity, cleat angle and impacting mass were replicated, and a raking phase where cleat force and acceleration of the foot were reproduced. The developed test method has the potential to be adapted for regulations or standards regarding laceration injury risk of cleated footwear, and it has been designed to give reproducible results across test centers and in future. Future research can use this method to quantify the laceration injury risk of individual cleat designs.

Disclosure statement

No potential conflict of interest was reported by the authors.

Funding

This research received no specific grant from any funding agency in the public, commercial, or not-for-profit sectors.

6. References

- Carville, K., Lewin, G., Newall, N., Haslehurst, P., Michael, R., Santamaria, N., & Roberts, P. (2007). STAR: a consensus for skin tear classification. *Primary Intention: The Australian Journal of Wound Management*, 15(1), 18–27.
- Chanda, A., & Unnikrishnan, V. (2016). Human Tissue Simulants for Study of Traumatic Brain Injury (TBI). *American Society for Composites Thirty-First Technical Conference*.
- Clarke, J., Carre, M. J., Damm, L., & Dixon, S. (2013). The development of an apparatus to understand the traction developed at the shoe-surface interface in tennis. *Proceedings of the Institution of Mechanical Engineers, Part P: Journal of Sports Engineering and Technology*, 227(3), 149–160.
<https://doi.org/10.1177/1754337112469500>
- Dennehy, G. (2008). *Dennehy -v- Adidas [Ireland] ltd*.
- Driscoll, H. F., Kirk, B., Holmes, C., Koerger, H., & Haake, S. (2009). Tracking of foot movement during sprinting in studded footwear. *Footwear Science*, 3(Supp 1), S51–S53. <https://doi.org/http://dx.doi.org/10.1080/19424280.2011.575820>
- Falland-Cheung, L., Pittar, N., Tong, D., & Waddell, J. N. (2015). Investigation of dental materials as skin simulants for forensic skin/skull/brain model impact testing. *Forensic Science, Medicine, and Pathology*, 11(4), 552–557.
<https://doi.org/10.1007/s12024-015-9718-0>
- Ford, K. R., Manson, N. A., Evans, B. J., Myer, G. D., Gwin, R. C., Heidt, R. S., & Hewett, T. E. (2006). Comparison of in-shoe foot loading patterns on natural grass and synthetic turf. *Journal of Science and Medicine in Sport*, 9(6), 433–40.
<https://doi.org/10.1016/j.jsams.2006.03.019>
- Gibbs, N. (1993). Injuries in professional rugby league prospective study of the South Sydney Rugby League Football Club. *American Journal of Sports Medicine*, 21(5),

696–700.

- Goodell, R. (2015). Official Playing Rules of the National Football League. *National Football League*.
- Grund, T., Senner, V., & Gruber, K. (2007). Development of a test device for testing soccer boots under game-relevant high-risk loading conditions. *Sports Engineering, 10*, 55–63. <https://doi.org/10.1007/BF02844202>
- Hall, M. J., & Riou, P. (2004). Football blades: a cause for concern. *British Journal of Sports Medicine, 38*(5), 642–644. <https://doi.org/10.1136/bjism.2004.012245>
- Lehner, S., Dießl, C., Chang, D., & Senner, V. (2013). Optimization of a Foot Model for the Evaluation of the Injury Risk during Cutting Movements in Football. *Procedia Engineering, 60*, 325–330. <https://doi.org/10.1016/j.proeng.2013.07.010>
- McIntosh, A. (2012). Biomechanical considerations in the design of equipment to prevent sports injury. *Proceedings of the Institution of Mechanical Engineers, Part P: Journal of Sports Engineering and Technology, 226*(3–4), 193–199. <https://doi.org/10.1177/1754337111431024>
- Neto, O. P., Silva, J. H., Marzullo, A. C. D. M., Bolander, R. P., & Bir, C. A. (2012). The effect of hand dominance on martial arts strikes. *Human Movement Science, 31*(4), 824–33. <https://doi.org/10.1016/j.humov.2011.07.016>
- Odenwald, S. (2006). Test Methods in the Development of Sports Equipment. In *The Engineering of Sport 6* (pp. 301–306).
- Oudshoorn, B. Y., Driscoll, H. F., Dunn, M., & James, D. (2016a). Causation Events of Stud Laceration Injuries in Rugby Union. *Procedia Engineering, 147*, 496–500. <https://doi.org/10.1016/j.proeng.2016.06.227>
- Oudshoorn, B. Y., Driscoll, H. F., Dunn, M., & James, D. (2016b). Pressure Sensor Calibration for Measuring Stud-player Impacts. *Procedia Engineering, 147*, 688–693. <https://doi.org/10.1016/j.proeng.2016.06.273>
- Oudshoorn, B. Y., Driscoll, H. F., Dunn, M., & James, D. (2017). Kinetic and kinematic analysis of stamping impacts during simulated rucking in rugby union. *Journal of Sports Sciences, In press*, 1–6. <https://doi.org/10.1080/02640414.2017.1346273>
- Oudshoorn, B. Y., Driscoll, H., Kilner, K., Dunn, M., & James, D. (2017). Prevalence

of laceration injuries in professional and amateur rugby union: a systematic review and meta-analysis. *BMJ Open Sport & Exercise Medicine*, 3(1), e000239.

<https://doi.org/10.1136/bmjsem-2017-000239>

Queen, R. M., Charnock, B. L., Garrett, W. E., Hardaker, W. M., Sims, E. L., & Moorman, C. T. (2008). A comparison of cleat types during two football-specific tasks on FieldTurf. *British Journal of Sports Medicine*, 42(4), 278–84; discussion 284. <https://doi.org/10.1136/bjsem.2007.036517>

Twomey, D. M., Connell, M., Petrass, L., & Otago, L. (2013). The effect of stud configuration on rotational traction using the studded boot apparatus. *Sports Engineering*, 16(1), 21–27. <https://doi.org/10.1007/s12283-012-0100-0>

van den Eijnde, W. A. J., Peppelman, M., Lamers, E. A. D., van de Kerkhof, P. C. M., & van Erp, P. E. J. (2014). Understanding the Acute Skin Injury Mechanism Caused by Player-Surface Contact During Soccer: A Survey and Systematic Review. *Orthopaedic Journal of Sports Medicine*, 2(5), 1–8. <https://doi.org/10.1177/2325967114533482>

World Rugby. (2015a). *Regulation 12. Provisions relating to players' dress*. Dublin.

World Rugby. (2015b). *Regulation 22 . Standard Relating To the Use of Artificial Playing Surfaces*. Dublin.

Zhang, M., & Mak, A. F. T. (1999). In vivo friction properties of human skin. *Prosthetics and Orthotics International*, 23(2), 135–141. <https://doi.org/10.3109/03093649909071625>