



# Software Defined Platforms for Visible Light Communication: State of Art and New Possibilities

Antonio Costanzo, Valeria Loscrì, Sandra Costanzo

## ► To cite this version:

Antonio Costanzo, Valeria Loscrì, Sandra Costanzo. Software Defined Platforms for Visible Light Communication: State of Art and New Possibilities. IEEE Communications Society Multimedia Communications Technical Committee (ComSoc MMTC) E-Letter, IEEE, 2017, 12 (3), pp.14-18. hal-01590267

HAL Id: hal-01590267

<https://hal.archives-ouvertes.fr/hal-01590267>

Submitted on 31 Oct 2017

**HAL** is a multi-disciplinary open access archive for the deposit and dissemination of scientific research documents, whether they are published or not. The documents may come from teaching and research institutions in France or abroad, or from public or private research centers.

L'archive ouverte pluridisciplinaire **HAL**, est destinée au dépôt et à la diffusion de documents scientifiques de niveau recherche, publiés ou non, émanant des établissements d'enseignement et de recherche français ou étrangers, des laboratoires publics ou privés.

# Software Defined Platforms for Visible Light Communication:

## State of Art and New Possibilities

Costanzo A.<sup>1</sup>, Loscri V.<sup>1</sup>, Costanzo S.<sup>2</sup>

<sup>1</sup>*FUN - Future Ubiquitous Network, Inria Lille - Nord Europe, France*

<sup>2</sup>*DIMES, University of Calabria, Italy*  
*valeria.loscri@inria.fr*

### 1. Introduction

The requirement of connected devices exponentially increases day by day as well as the bandwidth needed for novel applications. As a consequence of this, radio frequency spectrum becomes more and more crowded, thus leading to serious limitations in the diffusion of novel technologies when considering challenging environments such as hospitals and airplanes, where EM interferences are particularly unwanted. The integration of Visible Light Communication (VLC) in the existing infrastructures could provide a valid tool to address these issues. In this context, Software Defined concepts could significantly simplify the integration process, leading to the development of low cost and flexible architectures. To this end, Universal Software Radio Peripheral (USRP), designed and commercialized by Ettus Company and National Instruments, is emerging as a comparatively low cost hardware platform for software defined architectures, allowing rapid prototyping and test bed validations. The aim of the present work is to exploit the current literature in the framework of Software Defined Systems based on USRP platform for VLC purposes, while briefly highlighting some useful potentialities for the development of solid and flexible architectures.

### 2. Visible Light Communication: from Photophone to Software Defined VLC

The adoption of visible light for message transmission is one of the most ancient and intuitive techniques adopted in long distance communications. In the Roman Empire, a system of mirrors and shutters located on apposite towers was employed for communicating messages up to 20 km. The first modern communication in the visible spectrum, however, dates back to 1880, when Charles Sumner Tanter and Alexander Graham Bell invented the photophone. This device allowed speech transmission through the adoption of a light beam modulated by switching concavity and convexity of a reflecting screen [1]. In the first decade of 20<sup>th</sup> century, the German Siemens & Halske Company improved modulation using carbon arc lamps and provided commercial units for German Navy, while British Almerly adopted high infrared sensitive molybdenite cells. Before the second world war, many governments (Italy, Germany, US, Japan) attempted to develop optical wireless communication for military purposes. Then, advances in radio frequency communication and, further, the adoption of low loss optical fibers, caused a progressive decrease of interest in free space VLC. Due to the exponential increase of bandwidth needed by novel applications and the overpopulation of RF spectrum, in the last fifteen years, this topic has gained a new interest in the scientific community. The first significant work, addressing a visible light communication through a white Light Emitting Diode (LED), and discussing the main requirements of the devices, was done in 2003 at University of Keyo, Japan [2], while significant studies have been carried out by Haas et al. [3, 4]. Further, according to the rapid diffusion of efficient and low cost LED's, many authors started to deal with different aspects characterizing visible light communication, especially with respect to modulation and dimming support, until a first standardization of the physical and MAC layer, ratified by IEEE (802.15.7) and included in Wireless Personal Area Networks [5]. However, since novel advances are frequently addressed in last years, new standards should be provided. Nowadays, research in VLC follows two main directions: the first one implies an advance in the design of hardware components used for transmitting and receiving the optical signal (led, photodiodes, driving circuits, amplifiers etc.), with the aim to enlarge the bandwidth of the RF front-end and to allow the possibility of using a larger part of the huge unlicensed electromagnetic spectrum in the visible light frequencies (770THz-400THz). A second way, instead, mainly deals with a practical and low-cost integration of VLC elements into existing infrastructures. With reference to this latter scenario, the development of a solid Software Defined paradigm for VLC seems to be an attractive field in the improvement of this technology. As most of the signal operations are performed by software, low cost hardware could be used and an easier interface with other communication paradigms could be allowed for a practical integration in the existing infrastructures. An interesting low cost platform (OPEN VLC) based on a Beagle Bone Black module, has been recently developed by Wang et al. [6]. The platform, composed of a simple optical front-end, a set of essential medium access primitives and a basic interaction with internet protocols, allows a transmission up to 1 meter with a rate of 12.5 Kbit/s in its basic configuration. Despite the slow rate and the limited

communication distance, this architecture could be extended in order to be available for various applications, such as the passive ambient light recognizer described in [7]. An interesting preliminary work, employing the software defined platform USRP is provided in [8], where GNU Radio open source library is employed for signal processing and two simple applications (a chat service and a video download) are developed. The same authors provided a detailed description of the system in [9], where the standard 802.15.7 PHY I is achieved with a data transmission of 100kbit/s. An audio streaming transmission with similar performances is designed in [10]. In both cases, OOK modulation is adopted. Preliminary studies and a proof of concept on OFDM and PPM modulation using USRP platform and MatLab elaboration are provided in [11], while in [12] the same authors developed a driver topology able to drive an array of LEDs using a RPO-OFDM signal coming from USRP. A deeper investigation about Software Defined systems for VLC using USRP platform is provided in the next section.

### 3. Visible Light Communication through Universal Software Radio Peripheral

The first Universal Software Defined Radio, initially proposed by Ettus in 2006 [13], was obtained from USB2 interface. It owned a 30 MHz instantaneous bandwidth and it was well integrated into GNU Radio, an open source framework developed in the same period [14]. This transceiver, however, does not allow an easy design for a compact device; moreover, a full adaptability of the software code on the fly for different scenarios can be roughly achieved [15]. The second generation USRP (NI2920, NI2921 and NI2922), currently adopted in most of recent implementations, is provided by Gigabit Ethernet interface, owning a 50 MHz instantaneous bandwidth and easily interfaced through commercial software such as MatLab or LabView. It is also equipped with advanced FPGA, with an SD card for stand-alone operations. The main components of this architecture are shown in the block diagram of Fig. 1 [16].

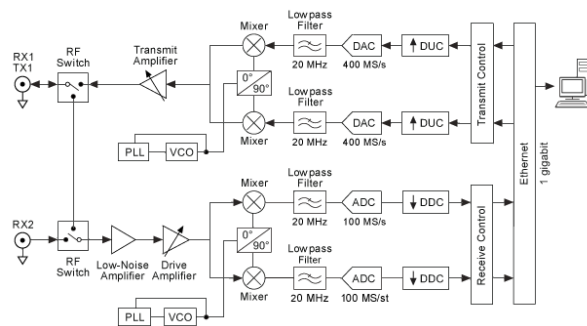

Figure 1. USRP NI2920 Architecture

Clock generation and synchronization, AD and DA conversions, host processor interfacing, and power regulation are provided in the motherboard, while operations such as amplifying, filtering, up and down conversion are implemented in the RF front end, or eventually in modular daughterboards, selected for the specific applications. Since a visible light source is typically incoherent and intensity modulation with direct detection (IM/DD) is mainly used, a low frequency or band-base daughterboard may be employed [10], such as the LFTX NI device [16], whose operative range ranges from DC up to 30 MHz, thus covering the entire bandwidth of most commercial LEDs. In terms of dedicated hardware, only the optical Rx and Tx front-ends are required, instead of antennas used in radio or radar applications [15], while most of the operations are directly performed and controlled on the fly by software. This aspect is particularly important to easily adapting existing signal modulation schemes to VLC transmission. Feeding and amplifying stage, led driving circuitry and the led itself in transmission, the photodiode and the trans-impedance amplifying in the receiver front end, could be chosen in order to find the appropriate trade-off between costs and performances. So, using the USRP and off-the-shelf components, it is possible to achieve reasonable results in terms of data rate, bit error rate and maximum transmission distance, as shown in Fig. 2 for the USRP based Software Defined VLC platforms described in the previous section.

	Modulation Scheme	Software Platform	Maximum Data Rate	Maximum Distance	BER
[9]	OOK / VPPM	GNU Radio Flexicom	100 kbit/s (1m)	4m	$10^{-4}$
[10]	OOK / VPPM	LabView	266kbit/s	1m	$10^{-3}$
[12]	RPO-OFDM	Matlab-Simulink	400Ksps	< 1m	$10^{-3}$

Figure 2. Performance of Software Defined VLC using USRP NI2920 Architecture

Results achieved in [9, 10, 12] prove the possibility of using a Software Defined System for short and medium range applications which do not require very high rate, thus avoiding the need of expensive dedicated hardware, and providing a flexible simple architecture. Since multiple USRPs could be connected to obtain a MIMO system, some authors recently considered also this scenario. An interesting paper deals with the possibility of using multiple USRP schemes for a full duplex OFDM link [17], while a 2x2 MIMO Software Defined VLC is addressed in [18]. These two-latter works demonstrate how a software defined platform could be expanded to achieve a more sophisticated and performing architecture. Many other several advantages can be provided by USRP, which are not yet addressed in current architectures, such as for example the possibility of adapting on the fly the equalization based on a bit error rate indicator. Another interesting aspect could be the possibility of regulating in real time the minimum transmitting power necessary for closing the VLC link within a dynamic environment. In the context of LI-FI paradigm, in fact, where the same lamp will be used for both lighting and providing signal communication, a software defined control of transmitted power could be useful for implementing a switchable modulation scheme allowing to provide a very low light intensity without turning off the link when high levels of environmental illumination are not required. Considering the nonlinearity of the optical components, different new adaptive techniques could be employed for limiting distortion, and various typologies of software defined filtering could be addressed, especially for future outdoor applications, such as in vehicular network applications. The possibility of designing a RF-VLC hybrid communication systems, using a USRP for a radio frequency communication and another one for the visible light link, could be an interesting issue for many applications, such as indoor geo-localization, Wi-Fi performance improving, or other future scenarios where the coexistence of VLC and RF link, or an adaptive handover between them, could be employed. A possible basic architecture is proposed in Fig. 3.

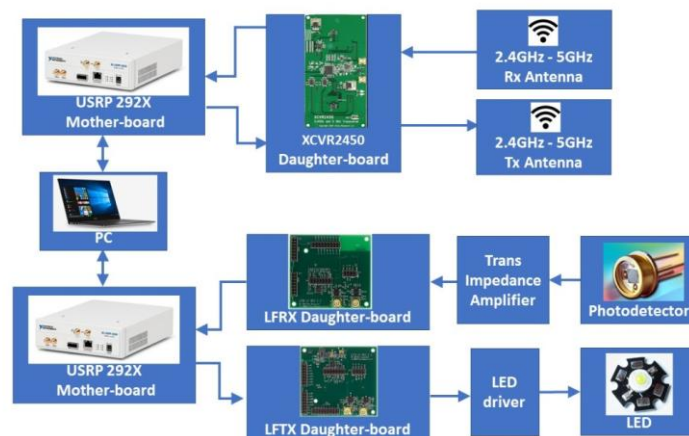

Figure 3. Hybrid Software Defined VLC – Wi-Fi using USRP NI292x Device

In this basic example, a XCVR2450 transceiver daughterboard is used for interfacing the dual band RF front-end covering Wi-Fi ranges and performing up-down conversion, filtering and amplification. Two baseband daughterboards, a LFRX in the receiving VLC path and a LFTX in the transmitting VLC path, are employed for filtering and other signal conditioning. Clock generation and synchronization, ADCs, DACs, and power regulation are performed independently by the two motherboards, through a centralized software coordination. The scheme proposed in Fig. 3 could be considered as a basic architecture for easily implementing a test bed for novel algorithms which employ both directional broadcast VLC channels and omnidirectional Wi-Fi links, recently proposed in literature [19,20] for providing additional capacity and reducing contentions in a crowded environment. Even if a proof of concept of a hybrid RF-VLC link has been addressed in [21], no software defined platform, for the best of our knowledge, has yet been considered with this aim. Providing a flexible and generic platform, however, could significantly speed up the development of novel applications using both VLC and RF links; a hybrid system, for instance, could be used for providing a reliable internet access point in running subway cars. A VLC broadcast channel, in fact, could be provided in each car, while Wi-Fi link could be still used in uplink. Since there is not a significant light interference between different cars, there could be an efficient frequency reuse allowing the system to work even in a crowded environment. Similar systems could be used in rail tunnels and similar environment. Other interesting applications could be developed in the field of indoor positioning, where an adaptive handover between Radio Frequency and VLC channels could be performed to benefit from the accuracy of the optical link where the environmental conditions are conducive, and switching in real time to RF localization where optical link fails. Similar ideas could be also developed in the field

of aviation, underwater communications, hospitals and healthcare, where a Software Defined flexible platform like the one briefly discussed in this work could significantly speed up both experimental tests and the development of real systems.

#### 4. Conclusions

A brief survey on Software Defined Visible Light Communication systems, based on USRP platform, has been outlined in this work. Some considerations about possible future applications of the above platform in the framework of Visible Light Communication scenarios have been discussed, and a basic example, showing a Hybrid VLC-LIFI architecture, has been provided. Based on the architecture we have considered in this work, we envisaged different potential future directions that could impose VLC as an effective communication technology in coexistence with other classical communication technologies based on RF signals.

#### 5. Acknowledgements

This work was partially supported by CPER DATA and by “21<sup>ème</sup> Fonds Unique Interministériel”, in the framework of the “Store Connect” project.

#### References

- [1] A. G. Bell, “The Photophone”, *Journal of the Franklin Institute*, vol. 110, issue 4, pp. 237-248, 1880
- [2] T. Komine, M. Nakagawa, “Fundamental Analysis for Visible-Light Communication System using LED Lights”, *IEEE Transactions on Consumer Electronics*, Vol. 50, No. 1, 2004
- [3] M. Z. Afgani, H. Haas, H. Elgala, and D. Knipp, *Visible Light Communication Using OFDM, Testbeds and Research Infrastructures for the Development of Networks and Communities*, 2006.
- [4] H. Elgala, R. Mesleh, and H. Haas, “Indoor broadcasting via white LEDs and OFDM,” *IEEE Trans. Consumer Electron.*, vol. 55, no. 3, pp. 1127–1134 (2009).
- [5] S. Rajagopal, R. D. Roberts, and L. Sang-Kyu, “IEEE 802.15.7 Visible Light Communication: Modulation Schemes and Dimming Support,” *IEEE Commun. Mag.*, vol. 50, no. 3, pp. 72–82, 2012
- [6] Q. Wang, D. Giustiniano, D. Puccinelli, “OpenVLC: Software-Defined Visible Light Embedded Networks”, *IEEE Wireless Communications*, April 2015
- [7] Q. Wang, M. Zuniga, D. Giustiniano. "Passive Communication with Ambient Light", *ACM CoNEXT*, 2016
- [8] C. G. Gavrincea, J. Baranda, P. Henarejos, Rapid prototyping of standard-compliant visible light communications system, *IEEE Communications Magazine*, Vol. 52, Issue 7, July 2014
- [9] J. Baranda, P. Henarejos, C. G. Gavrincea, “An SDR Implementation of a Visible Light Communication System Based on the IEEE 802.15.7 Standard”, *20th International Conference on Telecommunications*, Casablanca, 2013
- [10] W. Hussain, H. Fatih Ugurdag, M. Uysal, “Software Defined VLC System: Implementation and Performance Evaluation”, *4th International Workshop on Optical Wireless Communications (IWOW)*, 2015
- [11] Thomas D.C. Little and Hany Elgala, “Adaptation of OFDM under Visible Light Communications and Illumination Constraints”, *48<sup>th</sup> Conference on Signal, Systems and Computers*, 2014.
- [12] A. Mirvakili, V. J. Koomson, M. Rahaim, H. Elgala, T.D.C. Little, “Wireless Access Test-bed through Visible Light and Dimming Compatible OFDM”, *Wireless Communication and Networking (WCNC)*, 2015.
- [13] Ettus Research, a National Instruments Company, <https://www.ettus.com/>
- [14] Eugene Grayver, *Implementing Software Defined Radio*, Ed. Springer, pp. 145-146, 2013.
- [15] S. Costanzo, F. Spadafora, A. Borgia, O.H. Moreno, A. Costanzo, G. di Massa, “High Resolution Software Defined Radar System for Target Detection”, *Advances in Information Systems and Technologies*, pp 997-1005, 2013.
- [16] NI USRP-2920, NI USRP-2921 National Instruments Data-sheet, <http://www.ni.com>
- [17] W. Zhou, G. Villemaud, T. Risset.” Full Duplex Prototype of OFDM on GNURadio and USRPs”, *IEEE Radio Wireless Symposium*, Newport Beach, United States, 2014.
- [18] P. Deng, M. Cavehrad, “Adaptive Real-Time Software Defined MIMO Visible Light Communications using Spatial Multiplexing and Spatial Diversity”, *Wireless for Space and Extreme Environments*, 2016.
- [19] M. B. Rahaim, A. M. Vegni, T. D. C. Little, A Hybrid Radio Frequency and Broadcast Visible Light Communication System, *2nd IEEE Workshop on Optical Wireless Communications*, 2011.
- [20] X. Li, R. Zhang, L. Hanzo, “Cooperative Load Balancing in Hybrid Visible Light Communications and WiFi”, *IEEE Transactions on Communications*, Vol. 63 Issue: 4, pp. 1319-1329, 2015.
- [21] S. Shao, A. Khreishah, M. Ayyash, M. B. Rahaim, H. Elgala, V. Jungnickel, D. Schulz, T. D. C. Little, “Design of a visible-light-communication enhanced WiFi system”, *IEEE/OSA Journal of Optical Communications and Networking*, Vol. 7, Issue 10, pp. 960-973, 2015.