

NON-INVASIVE ELECTROMAGNETIC WAVE
SENSOR FOR FLOW MEASUREMENT AND
BIPHASE APPLICATION

CHEEN SEAN OON

A thesis submitted in partial fulfillment of the
requirements of Liverpool John Moores University for
the degree of Doctor of Philosophy

This research programme was carried out in
collaboration with University of Malaya.

FEBRUARY 2017

ABSTRACT

Multiphase flow measurement is important in chemical processing, water treatment and oil & gas industry. The multiphase flow sensor proposed in this research utilizes the resonant frequencies that occur inside a cavity and the differences in the permittivity of the measures phases. By measuring this response over the range of discrete frequencies the sample can be characterised. Polar material like water has relatively high permittivity ($\epsilon_r = 81$), while non-polar material such as oil and gas have low permittivity value ($\epsilon_r = 2.2-2.5$) and ($\epsilon_r = 1$) respectively. Hence, a small change in the water fraction may result in a comparatively large frequency shift. In this research, the electromagnetic cylindrical cavity sensor system successfully demonstrated its capability to analyze various fractions of water-gas mixture. The results were consistent in the case of both the static and dynamic flow. The statistical analysis of the captured data showed a linear relationship of the amplitude data with the change in the water fractions. It was also found that the technique was independent of the temperature change. The system was able to successfully detect the stratified, wavy, elongated bubbles and homogeneous flow regimes. The electromagnetic rectangular cavity sensor system is introduced to pick up the tiny shifts in the permittivity when the low permittivity material is used or temperature changes. The microwave sensor system is able to detect water-air fraction, water-oil fraction, oil-air fraction and water temperature. The novel solution of the combination of both cylindrical and rectangular sensor system demonstrates the ability to detect both high and low permittivity changes. These dual-cavity sensor cavity systems have been able to detect water level, flow regime and temperature in the pipe. It also demonstrates that microwave sensors based on the principle of changing permittivity can replace conventional measurement techniques.

ACKNOWLEDGEMENTS

Here I express my sincere gratitude to my supervisors, Professor Ahmed Al-Shamma'a, Associate Professor Kazi Md Salim Newaz, Professor Andrew Shaw, Dr Ahmad Badarudin and Dr Stephen Wylie for their visionary guidance, insightful advices and genuine supports during my Dual-PhD study, without which this thesis would not have been accomplished to its least content.

I would like to acknowledge the contribution of University of Malaya and Liverpool John Moores University in successfully jointly offered Dual-PhD program.

Thanks to Institute of Graduate Studies, University of Malaya who provide managerial support and aid during my PhD study. The Faculty of Engineering, University of Malaya play an important role in providing laboratory facilities and work space for my research.

The help and support provided by the staff and management team from the Department of the Built Environment is highly appreciated, especially the Radio Frequency & Microwave (RFM) group at Liverpool John Moores University in providing the laboratory facilities and conducting this research.

TABLE OF CONTENTS

ABSTRACT	ii
ACKNOWLEDGEMENTS	iii
TABLE OF CONTENTS	iv
LIST OF FIGURES	vi
LIST OF TABLES	ix
LIST OF ABBREVIATION	x
LIST OF APPENDICES	xi
CHAPTER 1: INTRODUCTION	1
1.1 Background of research	1
1.2 Problem statement	6
1.3 Significance of Research	12
1.4 Project aims and objectives	15
1.5 Scope and limitation of the study	16
1.6 Organization of thesis	17
CHAPTER 2: LITERATURE REVIEW	18
2.1 Introduction	18
2.2 Multiphase flow detection	18
2.3 Multiphase flow calculation	25
2.4 Electromagnetic waves propagation	27
2.5 Electromagnetic wave resonance cavity	29
2.6 Boundary conditions in waveguides	33
2.7 Microwaves sensor basic	35
2.8 Microwave Waveguides	38
2.9 Microwave sensors application/potential	42
2.10 Current available electromagnetic wave sensor	47
2.10.1 Attenuation sensor	47
2.10.2 Phase shift sensor	48
2.10.3 Transmission sensor	49
2.10.4 Reflection sensor	50
2.11 Summary	51
CHAPTER 3: METHODOLOGY	52
3.1 Introduction	52
3.2 Experimental setup	53
3.2.1 Microwave cavity	54
3.2.2 Static experiment and real time measurement	55

3.3	Labview software application	56
3.4	Samples tested and measurements procedure	57
3.5	Temperature effect study	60
3.6	Comsol simulation	61
3.6.1	Simulation using different level of water	61
3.7	Two phase flow experimental and real time measurement	64
3.8	Rectangular sensor cavity system	67
3.9	Summary	70
CHAPTER 4: RESULTS AND DISCUSSION		71
4.1	Introduction	71
4.2	Microwave spectrum analysis of the results	71
4.3	Statistical analysis of repeatability and amplitude change	77
4.4	Static Experiment	79
4.5	Temperature effect study	81
4.6	Two Phase flow Experiment	83
4.7	Wavy and elongated bubbles flow measurement and detection	87
4.8	Homogeneous flow measurement and detection	90
4.9	Dual Cavity sensor system	92
4.10	Summary	97
CHAPTER 5: CONCLUSION AND FUTURE WORK		98
5.1	Conclusion	98
5.1.1	Objective achieved	100
5.2	Recommendation	101
5.3	Future work	102
REFERENCES		103
LIST OF PUBLICATIONS AND PAPER PRESENTED		112
APPENDIX		117

LIST OF FIGURES

Figure 1.1	Microchannel heat sink	3
Figure 1.2	Various morphologies under slug flow conditions	4
Figure 1.3	A generic model of multiphase flow diagram for horizontal pipe	5
Figure 1.4	Multiphase flow meters application in multiple wells	8
Figure 1.5	Conventional multiphase flow measurement utilizing phase separators	9
Figure 1.6	Online multiphase flow measurement	9
Figure 1.7	Flow regimes effect on real measurement (true concentration = 25%)	11
Figure 2.1	Electromagnetic waves propagation in free space. The wave propagates in the x direction. and E and H are transverse.	27
Figure 2.2	Rectangular waveguide (a) and Cylindrical waveguide (b).	28
Figure 2.3	E field boundary condition. It meets boundary conditions.	33
Figure 2.4	E field boundary condition. It does not meet boundary conditions.	34
Figure 2.5	H field meets the boundary conditions.	34
Figure 2.6	Rectangular waveguide with internal dimension a and b.	39
Figure 2.7	Cylindrical waveguide with inner radius, r.	39
Figure 2.8	(TE_{10}) mode field configurations in rectangular waveguide.	40
Figure 2.9	Dominate mode (TE_{11}) field configuration in circular waveguide.	40
Figure 2.10	The basic geometrical configuration of a transmission sensor.	49
Figure 3.1	Electromagnetic wave cavity sensor development flow chat	52
Figure 3.2	Schematic diagram of the resonant cavity with pipeline	53
Figure 3.3	Cylindrical microwave cavity resonator with embedded antennas	54
Figure 3.4	Experimental setup of the measurement system showing the cavity, VNA, cables and connectors	55
Figure 3.5	Offline front panel display	56
Figure 3.6	The working principle of the electromagnetic microwave sensor flow chat	59
Figure 3.7	Partially filled horizontal cylinder	61
Figure 3.8	Schematic diagram of 60% of water in the pipe (front view).	62
Figure 3.9	Schematic diagram of 60% of water in the pipe (3D view).	63
Figure 3.10	Two phase flow experimental setup	64
Figure 3.11	Two phase flow experiment setup (Full View)	64
Figure 3.12	Schematic diagram of the two-phase flow experiment setup.	65
Figure 3.13	Rectangular sensor cavity design.	67
Figure 4.1	S_{21} (dB) measurements of the frequency response of water-air fractions using microwaves at 5-5.7 GHz	72
Figure 4.2	S_{21} (dB) measurements of the frequency response of water-oil fractions using microwaves at 5-5.7 GHz	73
Figure 4.3	Graph of the frequency shift for each of the water-air and water-oil volume fractions change	74
Figure 4.4	Electrical field intensity inside the cylindrical cavity.	75

Figure 4.5	Comparison of resonant frequency between experimental and simulation results	76
Figure 4.6	Average amplitude for each percentage of water with standard deviation error bars.	77
Figure 4.7	Relationship between the change in the volume fraction of water and amplitude in two phase systems	78
Figure 4.8	Graph of S_{21} (dB) versus frequency for different percentage of water.	79
Figure 4.9	Graph of Percentage of water versus S_{21} (dB)	80
Figure 4.10	Online front panel reading for different percentage of water.	80
Figure 4.11	Graph of S_{21} (dB) versus the frequency at different temperatures for 100% water.	82
Figure 4.12	Experimental of 20% of water flowing in the pipe.	83
Figure 4.13	Experimental of 80% of water flowing in the pipe.	84
Figure 4.14	Graph of S_{21} (dB) versus frequency for different percentage of flowing water.	85
Figure 4.15	Graph of Percentage of water versus power (dB).	86
Figure 4.16	Snapshot of the wavy flow.	87
Figure 4.17	Graph of the percentage of water versus time for the wavy flow.	87
Figure 4.18	Snapshot of the elongated bubbles flow.	88
Figure 4.19	Graph of the percentage of water versus time for the elongated bubbles flow.	88
Figure 4.20	Combination of stratified, wavy and elongated flow result.	89
Figure 4.21	Snapshot of the Homogeneous flow produced with different air input.	91
Figure 4.22	Graph of determination of the homogeneous flow type with varying air input using microwave response parameter S_{21} .	91
Figure 4.23	Graph of S_{21} versus frequency for different percentage of oil.	93
Figure 4.24	Graph of frequency shift versus oil fraction increment.	94
Figure 4.25	Graph of S_{21} versus frequency for different temperature.	94
Figure 4.26	Graph of frequency shift versus temperature change.	95
Figure 5.1	Dual microwave sensor cavity system.	99
Figure 1	Multiphase flow metering system measurement for the relative volumetric proportions and temperature	149
Figure 2	Apparatus utilized for relative volumetric proportions and temperature detection	150
Figure 3	Flowchart of the relative volumetric proportion measurement	151
Figure 4	Comparison of water-air fractions in the fluid mixture	152
Figure 5	Comparison of resonant frequency between experimental and simulation results	153
Figure 6	Graph of S_{21} versus frequency at different temperature for 100% water	154
Figure 7	Graph of frequency shift versus oil fraction increment	155
Figure 8	Graph of frequency shift versus temperature change	156
Figure 9	Cylindrical cavity 3D view	157

Figure 10	Cylindrical cavity front view	158
Figure 11	Cylindrical cavity top view	159
Figure 12	Cylindrical cavity side view	160
Figure 13	Rectangular cavity 3D view	161
Figure 14	Rectangular cavity front view	162
Figure 15	Rectangular cavity top view	163
Figure 16	Rectangular cavity side view	164
Figure 17	Antenna 3D view	165
Figure 18	Antenna front view	166
Figure 19	Antenna side view	167
Figure 20	Dual microwave cavity sensor 3D view	168
Figure 21	Dual microwave cavity sensor front view	169
Figure 22	Dual microwave cavity sensor back view	170
Figure 23	Dual microwave cavity sensor side view	171
Figure 24	Labview data record front panel	172
Figure 25	Data record block diagram (first half)	173
Figure 26	Data record block diagram (second half)	174
Figure 27	Labview data record and control front panel	175
Figure 28	Data record and control block diagram (first half)	176
Figure 29	Data record and control block diagram (second half)	177

LIST OF TABLES

Table 3.1	List of two phase system of water-air and water-oil tested for the monitoring and analysis of the volume fractions	57
Table 3.2	Analysis of the water sample to monitor the change in temperature and its impact on the microwave response frequency/amplitude	60
Table 3.3	Height of water in different percentage of water.	62
Table 3.4	List of two phase system of oil-air tested for the monitoring and analysis of the volume fractions	68
Table 3.5	List of temperature of fully filled pipe for the temperature detection	69
Table 4.1	Analysis of the water sample to monitor the change in temperature and its impact on the microwave response frequency/amplitude	81
Table 4.2	List of two phase system of oil-air tested for the monitoring and analysis of the volume fractions	92
Table 4.3	Average frequency and standard deviation for each temperature	95

LIST OF ABBREVIATION

ANN	Artificial Neural Network.
LJMU	Liverpool John Moores University.
MPM	Multiphase Flow Meter.
NMR	Nuclear Magnetic Resonance.
RFM	Radio Frequency & Microwave.
TE	Transverse Electric.
TM	Transverse Magnetic.
VNA	Vector Network Analyzer.
WLR	Water-in-liquid Ratio.

LIST OF APPENDICES

APPENDIX A Award	118
APPENDIX B Patent	119
APPENDIX C Dual Microwave Cavity Drawing	157
APPENDIX D Labview	172

CHAPTER 1: INTRODUCTION

1.1 Background of research

Multiphase flow is a real world phenomenon exists in many engineering industries like petroleum, chemical processing, petroleum and even in nature, like living organism. The interaction between different phases and their highly complicated and random movement, hence, the flow distribution and multiphase flow mixture is widely studied for engineering application. The pattern of the flow is defined as the major feature of the multiphase flow and the flow distribution. When both liquid and gas mixture is flowing inside a pipe, many flow patterns can be identified depending on the velocity of each flowing liquid, a typical flowing regime can include stratified, homogeneous, slug, elongated bubbles and annular flow. The energy and mass transport mechanism varies for different kind of flow regimes. It is vital to recognise the flow pattern in order to understand the physical phenomena and the mechanism of multiphase flow. Flow regimes are one of the most important aspects affecting accuracy of the multiphase flow measurement especially for the phase fraction and flow rate. Consequently, it is of great scientific and technological importance to research and develop methods of sensing multiphase flow regime.

Numerous flow patterns of gas-liquid stratified and gas-liquid slug flow occurs in the chemical, civil, oil and gas, nuclear and water treatment industries. The flows can be characterized by observing sequence of elongated bubbles surrounded by liquid flows that may contain tiny bubbles inside the fluid. This phenomenon can be separated into two groups, terrain and hydrodynamic slugging. The terrain slugging is the result of changing of flow line topography which contributes to a local rise and fall in the flow. The hydrodynamic slugging is the normal slugging pattern often happening in straight fluid flow. Due to its transient and intermittent behaviour, it is very hard to accurately predict the flow characteristics. Hence, reliable sensor is crucial for the safety, operations

and cost efficient design of industrial facilities.

Slug flow occupies the biggest share of all the in flow-pattern maps particularly the upward inclination pipe. Over the past few decades, huge attention has been focusing on slug flow characteristics study inside flowing pipelines. Researchers were highly interested in hydrodynamic characteristics such as slug liquid hold-up, slug length distributions, slug frequency and translational velocity (the study of interface velocity between liquid slug and bubble). Other slug or chunk flow related studies were focused on higher liquid viscosities (Gokcal et al., 2009). The period flow of the liquid slugs and the alterations in the flow velocities of different phases of fluid makes the research of slug or chunk flow interesting and challenging.

For horizontal and slight incline or decline pipeline systems, slug flow and elongated bubbled flow are among the frequently reported flow-pattern in industrial application as well as academia. The turbulence level in the flowing liquid slug is the major different between these two flow regimes. For the slug flow pattern, particularly for low viscosity fluidic system, the liquid slug-body turbulence level is relatively high which means it creates a recirculation zone at the front of the slug. The recirculation zone forces the gas entrainment into the liquid slug-body. In contrast, for the case of elongated bubble flow-pattern, the low turbulence level in the liquid slug-body zone result in no gas entrainment. As far as constant superficial liquid velocity, geometric and fluid properties are concerned, slug flow happens at comparatively high superficial gas velocity compared to the elongated bubbles flow pattern (Kesana et al., 2017).

Multiphase flow is also important in heat transfer. Heat transfer inside microchannels under the conditions of phase change received increasing attention due to the ongoing trend of miniaturization of various engineering and industrial applications, for instance fuel cells, heat transfer electronics, green energy technologies and many other applications. Figure 1.1 shows the heat sink using microchannel technology.

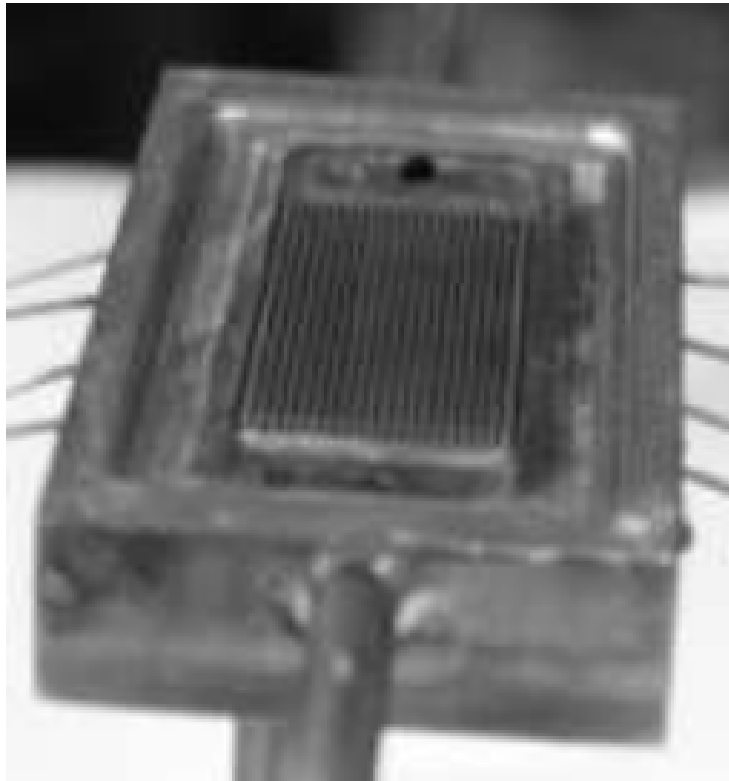

Figure 1.1. Microchannel heat sink

The permittivity of a nominally homogeneous mixture depends upon the volumetric ratio of the constituent materials and upon the permittivity of the individual components. Microwave instruments exploit this fact to analyze the properties of substances or the composition of mixtures by measuring and analyzing various attributes of a microwave signal or set of signals that depend directly upon the permittivity of the substance or mixture. For example, instruments in a variety of configurations are available which measure the attenuation or phase shift of signals that are transmitted through an unknown mixture.

Two-phase stratified flows are vital in many industrial applications, for example horizontal heat exchanger, industrial pipelines and fluid storage tanks. Flow characteristics such as the measurement flow regimes, pressure drops and flow rates have been the subject of interest of engineering as well as researches around the world. (Taitel & Dukler, 1976) introduce flow maps which forecast the transitions between different flow regimes

inside horizontal pipes. Special attention is given to the study of wavy flow, elongated bubble flow, slug flow and smooth stratified flow regimes. Figure 1.2 shows the many morphologies under slug flow conditions (Höhne & Mehlhoop, 2014).

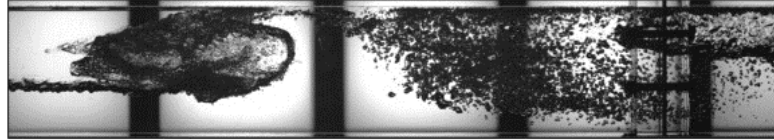

Figure 1.2. Various morphologies under slug flow conditions

Characteristically, free surfaces manifest such as two phase stratified flow, wavy flow, slug flow in horizontally flow domain where liquid and gas are divided by the force of gravity. The numerical simulation of slug flow regime is a very sensitive case study for the modelling setup due to interfacial friction quality of the model with respect to the momentum transfer. Many geometrical and multidimensional numerical models were developed to simulate stratified flows inside a horizontal pipe. All these methods, in principle are able to capture accurately most of the physics in the stratified flow condition. On the other hand, they were unable to capture all the morphological formation for instance droplets and small bubbles due to the grid size are not sufficiently small in the modelling.

It is observed that various flow regimes are formed as a result of the physical distribution of the fluid phases in a pipeline section (Amdal et al., 1995). The flow regimes are formed due to the magnitude of the force acting on the fluid. The flow regimes could be significantly influenced by the varying degrees of forces such as surface tension, oil, gas and water flow rates and properties, the pipe diameter and pipe inclination can also significantly influence. In horizontal and near horizontal pipe geometry configuration of the general flow regime of streams can be classified as: stratified, elongated bubbles, bubbles, wavy, slug, mist and annular flow. Figure 1.3 depicts these flow regimes for horizontal pipeline geometry as a function of superficial liquid (oil and or water) and gas velocities. The main mechanisms of formation these flow regimes are classified into three effects:

1. Transient: this effect happen in the event of alterations of system boundaries because of the changes in the flow loop introduced by system control, for instance the opening and closing of valve.
2. Geometry: alteration in the pipe line geometry or inclination has been considered in this effect. The pipelines could be installed in vertical, horizontal, inclined or declined position.
3. Hydrodynamic: consists of fluid properties, fluid flow rate or both.

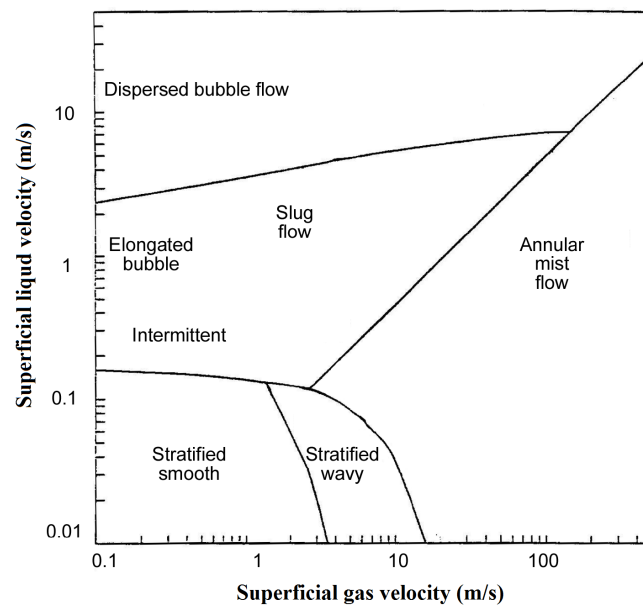

Figure 1.3. A generic model of multiphase flow diagram for horizontal pipe

1.2 Problem statement

Various Multiphase Flow Meter (MPM)s for measuring the mixture of different fluids, for instance, water-oil mixture are currently available on the market today. Many of the MPMs are based on radioactive radiation technology, others are capacitance and electromagnetic wave based sensors. Generally, radioactive sensors are not very suitable owing to environmental and safety issues posed by the radiation and also security concerns. The capacitive based sensor detects the permittivity two phase flow at low frequency compared to the microwave sensor. Owing to their complex array construction, capacitive sensors can be very slow to measure the fluid fraction compared to other competing technologies. Moreover, it is sensitive to the fluid temperature change. The capacitive sensor likewise needs a complex design utilizing a dielectric material as a protection to avoid direct contact between flow fluid and the electrodes. Ultrasonic sensor is a relatively new technology in multiphase flow measurement, however, resolution, repeatability and sensitive temperature changes make it not so popular in industrial applications. On the other hand, the above identified problems were not synonymous with the microwave sensors.

It is crucial to measure gas or liquid fraction, phase velocities and the Water-in-liquid Ratio (WLR), in order to acquire the production flow rates of oil and water. Several MPMs have been designed and developed by companies and research organizations, utilizing various measurement technologies. Although those MPMs are commercially available, there are number of challenging problems yet to be solved, for instance, different flow regimes, changes in the fluid properties and sensitivity of the measurement of phase-fraction.

The product of an oil and gas reservoir consists of a mixture of oil, gas, and water. During the oil extraction, gas and water are produced as by-products as a natural phe-

nomenon, which occurs in the petroleum field. In order to maximize the amount of oil that can be retrieved, water and gas are often injected at various locations into the well. Thus, monitoring and measuring the output of oil, gas and water mixture are crucial requirements. The information not only can be used to optimize both the operation and transportation management but to enhance the quality of production as well (Al-Hajeri et al., 2009).

Increased offshore exploration and production of the oil and gas industry lead to the transportation of fluids over relatively long distances. Usually, the fluid consists of water which already existed in the stratum. The percentage of water often increases during the production life of a well (X.-X. Xu, 2007). Many wells are still considered to have economic production even if the percentage of water in liquid phase exceeds 90% (Hewitt, 1997b). The presence of water must be taken into consideration when designing and predicting the flow behaviour in both wells and pipelines.

Conventionally, the flow rates of well production were measured by first separating the phases and measuring the output of each separated fluid by conventional single phase MPM. The drawback of this conventional technique is it takes several hours to determine the flow rates for every single well and for well production control, while there might be ten or more wells to be monitored in the oil fields. Furthermore, the water-oil-gas separators are maintenance intensive and expensive (Wang et al., 1998).

MPM offers one of the alternatives to replace the utilization of conventional separators. In the oil and gas industry, generally, it is recognized that MPMs could greatly benefit the production allocation, monitoring, reservoir management, well testing and layout of production facilities (Thorn et al., 1997). Figure 1.4 shows the offshore oil and gas production that involve several adjacent wells (Al-Kizwini et al., 2013). The data captured during the production of these wells can help in estimating the performance of each individual well. The data gathered can be used as a reference to locate anomalies

during production, for example water or gas breakthrough in a production well.

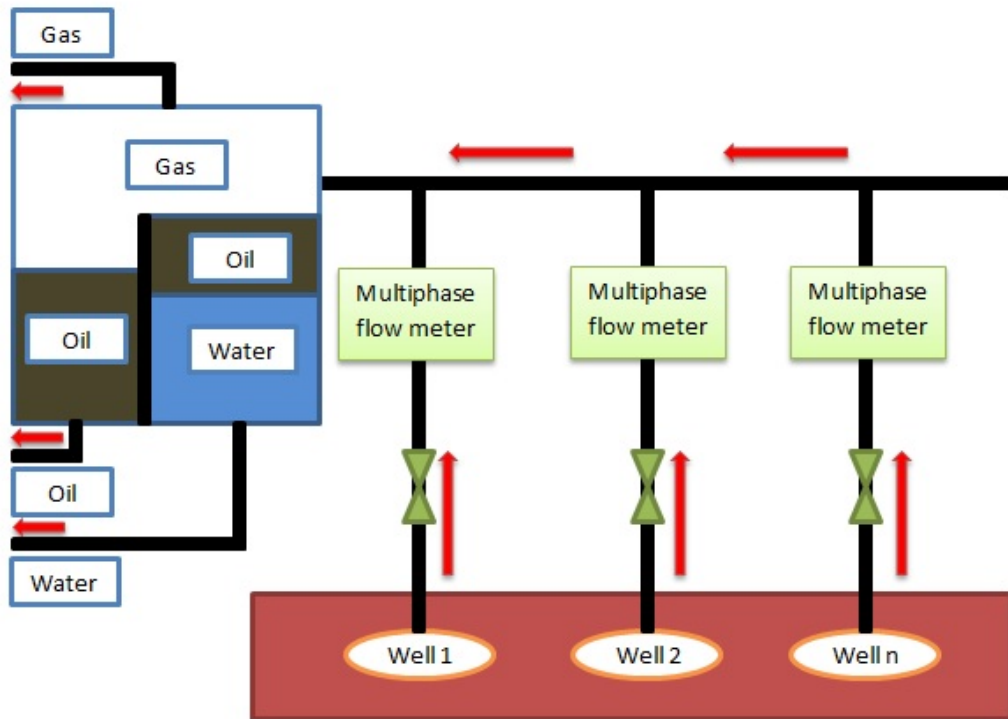

Figure 1.4. Multiphase flow meters application in multiple wells

Another drawback of conventional multiphase flow measurement is the utilization of phase separators in a complicated network of pipelines which also occupy valuable spaces. Figures 1.5 and 1.6 show the Conventional Multiphase flow measurement utilizing phase separators and Online Multiphase flow measurement respectively (Amdal et al., n.d.). The MPM can be installed and used in the same way as the test separator. It will cut down on the number of unnecessary pipeline and simplify the piping network. Moreover, MPM responds more quickly to the change in the well fluids which also needs less time to stabilize.

Petroleum resources are finite and becoming ever more elusive. As oil reserves are depleted over time, efficient management of existing reservoirs is becoming even more important. For the purposes of reservoir management, the oil and gas industry needs a multiphase flow meter which is compact and capable of measuring the flow rates con-

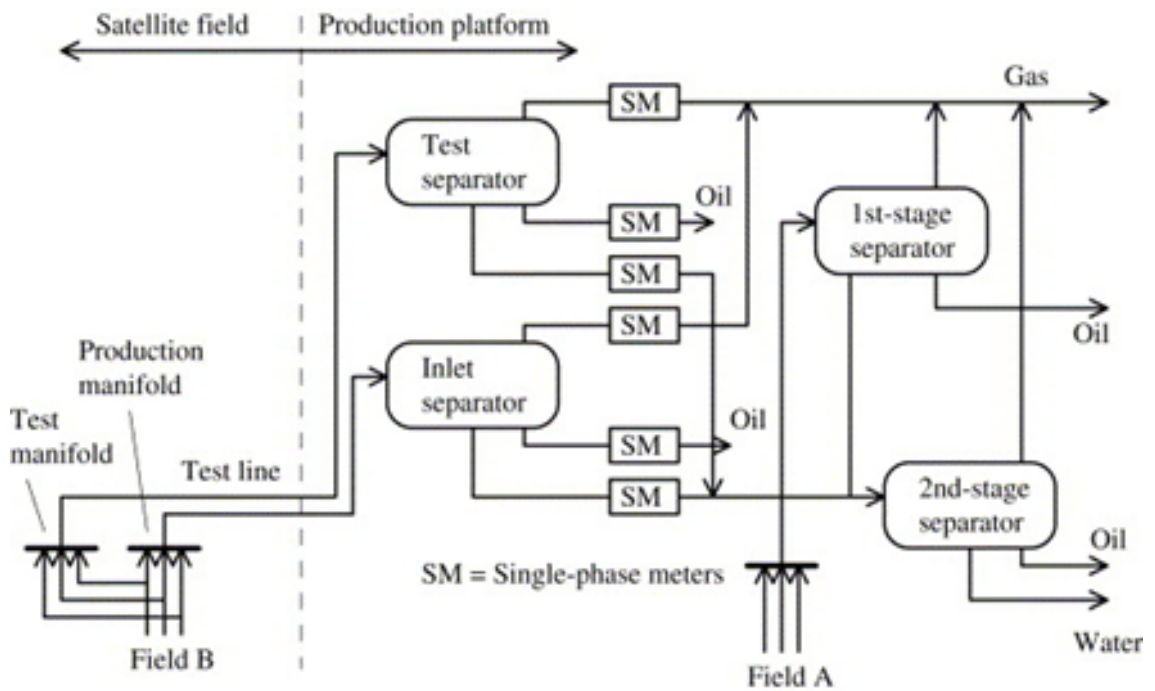

Figure 1.5. Conventional multiphase flow measurement utilizing phase separators

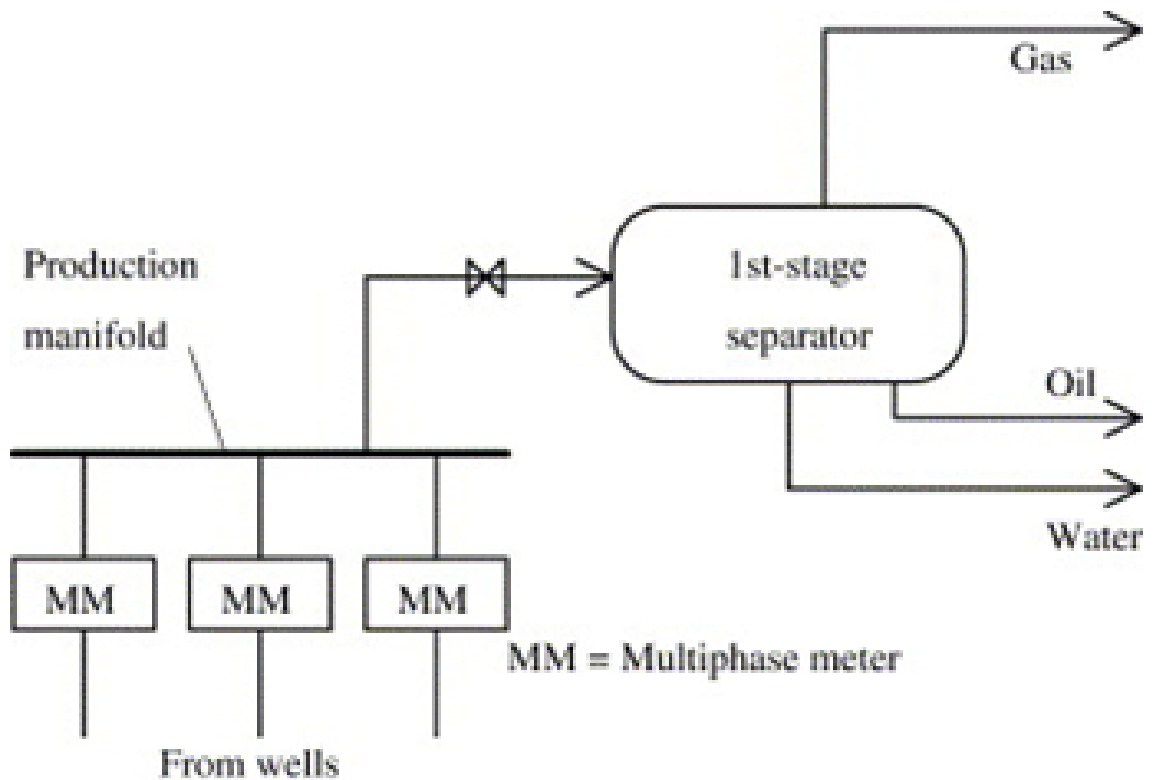
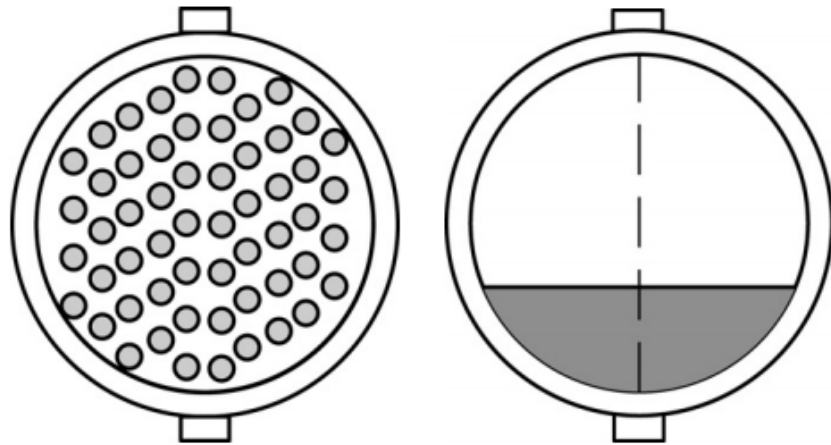

Figure 1.6. Online multiphase flow measurement

tinuously within about 5-10% error (Ashton et al., 1994). Overall, the measurements at the collecting platform are normally the mixture of product from several wells, as a result production data from each individual well are missing. Many researchers in various fields developed different types of measurement techniques for extracted multiphase flow which

involve the γ -ray radiation (Roach & Watt, 1996), process tomography and impedance techniques (Dykesteen et al., 1985), which are expensive, inaccurate and hazardous to health.

Another major problem faced by current available MPMs is flow regime dependent. Figure 1.7 shows three cases of oil-gas flow regimes with the oil volume fraction of 25%. However, the readings obtained with three different flow regimes, which were annular, homogeneous and stratified flow regimes, by using a conventional calibrated MPM for homogeneous flow volume fraction were inaccurate (Ismail et al., 2005). Therefore, flow regimes will add to considerable errors due to the localised sensing path. Thus, the conventional MPM is only limited to a range of flow regimes (quasi-homogeneous or homogeneous flow). Flow regime independent measurements are considered vital for down hole flow measurement for multilateral wells, inclined or horizontal due to the flow regimes tending to stratify or becoming other types of flow regimes that are difficult to measure with the currently available MPMs (Hammer & Johansen, 1997).



(a) Homogeneous
(measured concentration =25%).

(b) Stratified (measured concentration=30%).

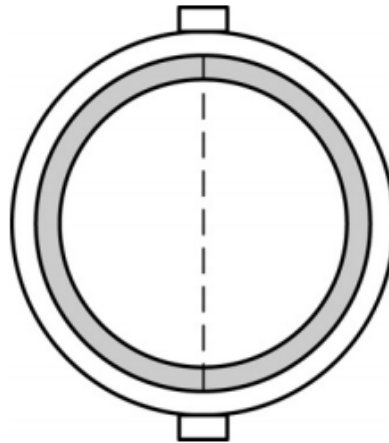

(c) Annular (measured concentration=13.4%).

Figure 1.7. Flow regimes effect on real measurement (true concentration = 25%)

1.3 Significance of Research

During the oil extraction, water and gas are produced as by-products. To maximise the production of oil from a reservoir, water and gas are often injected into the well. Water is used to maintain the pressure whereas the gas is used to reduce the viscosity of the oil. To enhance the production and optimise the process it is crucial to monitor the output of the mixture of water, oil and gas. The monitoring also helps to improve the operational and transportation management (Al-Hajeri et al., 2009; Alhajeri, 2010). Water naturally occurs in the stratum and the percentage of water often increases with the production life of a well (X.-X. Xu, 2007). The water fraction also increases as the well is flooded with water. Many wells are still considered to be economic if the percentage of water in the liquid phase is more than 90% (Hewitt, 1997a). It is, therefore, important to consider the presence of water when predicting and designing a method to monitor flow behaviour in both pipelines and wells. In recent years, a numbers of studies have been published on water, oil and gas flow in pipes (De Castro et al., 2012; J.-y. Xu et al., 2008; Rodriguez & Oliemans, 2006; Hapanowicz, 2008).

Conventionally, single phase monitoring techniques are utilised to measure the flow rates of well fluids by separating the mixture. The drawback is the time needed, which can take up to several hours, to obtain the flow rate of each well because each phase has to be separated before measuring it. The complexity of this technique increases when it comes down to monitoring up to 10 or more wells in the oil field which could be substantially time consuming and inconvenient. In addition, the oil-water-gas separators are expensive and maintenance-intensive (Wang et al., 1998).

One alternative to replace the water-oil-gas separators is the utilization of MPMs. It is acknowledged that MPMs could bring benefits to the oil and gas industry in terms of layout of production facilities, reservoir management, regular monitoring, production al-

location and well testing (Thorn et al., 1997). Ideally MPMs should be accurate, reliable, non-intrusive, compact and capable of measuring the flow rates continuously to within 5-10% of error (Ashton et al., 1994). The data captured during the production of these wells can help in estimating the performance of each individual well. The data gathered can also be used to locate a production anomaly, for instance, a gas or water breakthrough in the production well (Al-Kizwini et al., 2013).

One of the solutions for the above problem is to provide non-intrusive and intrusive methods for detecting the fluid constituents in a fluid mixture passing through a tube. The design employs a pair of cavity sensors for performing non-intrusive measurement of fluid compositions, volume fractions and temperature in real-time. The objective of this novel design sensors is to enhance the robustness of the real time measurement of oil well streams, to provide a low-cost MPM solution and to continuously monitor the two phase flow.

The research team at Radio Frequency & Microwave (RFM) of Liverpool John Moores University (LJMU) focus on microwave sensing research. This research group conduct experiment and investigation into many kinds of microwave sensor for industrial applications. The research team at RFM Group had previously attempted the use of electromagnetic wave sensors for two-phase flow monitoring. Al-Kizwini studied the water-gas mixture using low electromagnetic wave frequency between 240MHz and 330MHz (Alhajeri, 2010; Al-Kizwini et al., 2013). However, there were certain drawbacks in the study, these were:

1. Low repeatability of the results.
2. Lack of information on the temperature dependence
3. Lack of information on the monitoring of two phase fluid flows, i.e. water-air and oil-water.

4. The antennas were in contact with water that may cause rust and error in measurements.

This experimental study extended the work carried out by Al-Kizwini to address the above aspects as well as to make the measurements more reliable, accurate and repeatable. An electromagnetic wave cavity sensor was designed and used to measure the fractions of two phase water-air and oil-water stratified flows in the pipe. The outer cavity was left empty whereas the pipe inside was filled with the two phase fluids. To measure the former, i.e. water-air mixture, water was added in the pipe in various percentages to air. In the latter case, water in various percentages to oil was added in the pipe. Any scientific measurements and monitoring system needs to be reliable and repeatable. Hence, measurements were carried out at higher frequencies, more specifically in the microwave region, in contrast to previous research to address the repeat-ability. The measurements were also carried out at a range of temperatures in the case of the water-air phase system to study the impact of temperature change on the microwave measurements. It is important to mention that this study only focused on one type of flow, i.e. stratified. Further research work is needed to measure other flow types using this technique. The new knowledge will contribute to the team and microwave sensor community the understanding of multiphase flow detection and temperature effect under different kinds of flow regimes.

1.4 Project aims and objectives

This research was set up to develop a novel non-intrusive sensor that can detect in real time the two phase flow regimes under continuous flow condition. The main feature of this sensor is to have the capability to monitor the flow regimes continuously without touching the flowing fluid inside the pipe so it gives live data of what is the fraction of different fluids for chemical and oil and gas industry for production monitoring proposes. Other features of the developed sensor are that it should be simple, require little maintenance and robust that would minimize the running cost. This aim was met by applying the following objectives:

1. Test an experimental sensor under static and stratified condition (water-air and water-oil).
2. Determine the effect of temperature on the above measurements and devise a method to negate the temperature effect.
3. Design an experimental rig for testing the sensor under continuous flow conditions with different flow regimes.
4. Run Comsol simulations to compare the experimental results and determine the validity of the experiment.
5. Design an experimental sensor for low permittivity fluid under stratified condition (oil-air).

1.5 Scope and limitation of the study

The scope of study in this report will include, but not be limited to fundamental studies with substantial analysis on the non-invasive multiphase flow detection in the chemical, water treatment and oil and gas industries. These include studies on the microwave cavity sensor to detect static conditions with two stratified phases (water-air and water-oil), the effect of temperature of the fluids, different flow regimes detection and run simulation to verify the results. These are the crucial information for the multiphase flow measurement in industry applications. As mentioned, variable parameters used are the frequency of the microwave generated, size and type of the resonant cavity and flow condition that the laboratory facilities can generate. The approach for this research will be devised based on publications from the past researches. Results obtained in the experiment will be verified using the simulation results obtained from Comsol simulation package. To solve the problem during the investigation, new ideas and designs will be introduced. The scope will not involve oil and gas standard parameters due to safety and cost involved and only focus on laboratory scale of experiment. The temperature involved in the study will be limited to less than the boiling point of water. It is hope that the results and knowledge from this research will provide better understanding and contribute to the development of multiphase flow sensor and related areas.

1.6 Organization of thesis

Chapter 1 explains about research background, problem statement, project description, research objectives and scope. This will provide a general overview for the research project. Moreover, it will also explain how relevant and significant the research is in the current industry.

Chapter 2 contains a literature review made from various journals, publications, conference papers and articles on the field area. Emphasis is on, but not limited to the application of non-invasive multiphase flow detection in the chemical, water treatment and oil and gas industries. Basic principles of microwave, advantages and disadvantages of microwave cavity sensor are among the fundamental issues discussed.

Chapter 3 is dedicated to the methodology used for this research. The parameters and design experiment are discussed in detail in this section. This chapter will discuss the methodology on how to use this technology for the non-invasive sensing of two phase flow. A series of experiments is planned and conducted to validate the usability of the design.

Chapter 4 details results and discussion obtained from experiments and simulations. The response of the frequency to the changes of fluid fraction is identified and shown in this section. Comsol simulation is carried out to verify the results. A novel solution of incorporating a rectangular cavity to the system to pick up the tiny shift of the frequency will be implemented. Selected cases will be chosen for comparison between static and stratified flow for validation purpose.

Chapter 5 concludes overall findings for the project and significance of the results. This chapter will also explain whether or not all research objectives drawn in Chapter 1 have been achieved, there are three sections in this chapter, conclusion, recommendations and future works.

CHAPTER 2: LITERATURE REVIEW

2.1 Introduction

This chapter contains a literature review made from various journal, publications, conference papers and articles on the field area. Emphasis is on, but not limited to, the application of non-invasive multiphase flow detection in the chemical, water treatment and oil and gas industries. Basic principles of microwave, and advantages and disadvantages of microwave cavity sensors are among the fundamental issues discussed.

2.2 Multiphase flow detection

Two-phase flows are commonly encountered in various engineering applications such as chemical industry, heat exchangers, oil and gas industry, rocketry, nuclear engineering and food production (Thorn et al., 2012; Huh et al., 2009). Out of these, the liquid-gas flow is one of the most common types of flow. As the interaction takes place between the gas and the liquid during the flow process, the distribution and the shape of the interface of two-phase flow changes (Rao et al., 2011) The characterization of the behaviour of gas-liquid flow is very important for the sake of understanding the measurements as well as the chemical processes associated with it. Thus, multiphase flow measurement before processing within the pipeline for the purpose of production is essential for safety and efficiency (Dukler & Hubbard, 1975).

The product of an oil and gas reservoir consists of a mixture of oil, gas, and water. During the oil extraction, gas and water are produced as by-products as a natural phenomenon, which occurs in the petroleum field. In order to maximize the amount of oil that can be retrieved, water and gas are often injected at various locations into the well. Thus, monitoring and measuring the output of oil, gas and water mixture are crucial. The information not only can be used to optimize both the operation and transportation management but also to enhance the quality of production (Al-Hajeri et al., 2009).

Single phase flow is well characterized by turbulence, velocity profile and the boundary layer whereas these are not suitable to describe the multiphase flows phenomenon (Corneliussen et al., 2005). Generally, MPMs are designated according to flow regimes. These flows could be either horizontal, vertical or incline orientations. Flow regimes are heavily influenced by their constituent transport properties (surface tension, density and viscosity), the orientation and the flow-line geometry and individual phase flow rates (Thorn et al., 2012). In order to determine phase fractions and achieve efficient operation of the multiphase flow systems, the requirement to identify the flow regimes in multiphase flow is vital (Arvoh et al., 2012). In the recent past scientists have developed several mechanisms to classify flow regimes according to the topological similarities. Typical two phase flow in horizontal pipes is classified into elongated bubble, annular, slug, wavy and stratified flow pattern, whereas the flow of liquid-gas in vertical direction is classified into the flow regimes churn, annular, bubbly and slug flow (Falcone et al., 2009). To study two phase flow the different regimes are required to be identified from the sensor signals of the flow by using a pattern recognition technique.

Different techniques have been applied for analysis of two phase flow. The advantages of the non-radioactive MPM over MPM techniques involving radioactive sensors have been discussed by some authors (Arora, 2009). Considering cost involvement the non-radioactive MPMs do not use radioactive elements so they are much cheaper to construct. Also an additional advantage is that, the operational cost is very much less compared to the radioactive instrumentation due to the enormous expenditure associated with environmental, health and safety requirements for the latter. Furthermore, non-radioactive MPM do not require specialized packaging and the procedure for customs clearance is much simpler, thus the expenditure of exporting and importing are substantially lower. As for applications for mobile non-radioactive MPMs, they are applicable for well testing and during the fluid drilling phase for early production checks. None of the special

safety requirements associated with radioactive MPMs is needed.

Multiphase flows characterized by the use of the impedance technique were studied as early as the 1960s (Falcone et al., 2009); they were also used in characterization of commercial MPMs (Goncalves et al., 2011) and (Scheers, 2001). Flow pattern measurement using the impedance methods is very sensitive to the flow pattern inside the channel (Falcone et al., 2009) and is affected by the phase inversion problem, for example, a change from capacitance to conductance has appeared when the flow change from oil to water is continuous. On the top of that, this electrodes operates on direct contact with the flow (this is an invasive method of approach), which in some cases may lead to difficulties for the instrument production and in some other cases it will distort the true reading. A system for overall flow rate measurement combining differential pressure cone meter and conductance-ring sensors for phase fraction detection was introduced by the researchers(Tan et al., 2013). The system was introduced for the application of the measurement for water–oil flows, whereas the authors also claimed that the introduced methodology could be further used for gas–liquid two-phase flows. However, for these flows no experimental data are generated and presented yet. The instantaneous void fraction distribution in pipe flow could be determined by the wire-mesh impedance technique (Prasser et al., 1998) and (Da Silva, 2008). This technique is considered as simple, high temporal resolution and low cost when it is compared to other imaging systems, although it operates though intrusion, which is restricted to the laboratory environment. This technique is still safer, cheaper and faster than radiation based tomographic techniques. With reference to the Electrical Capacitance Tomography, this can also be readily digitized and automated. Nonetheless, its spatial resolution is inferior to that of nuclear based tomography and it is also subject to the phase inversion problem (Falcone et al., 2009).

Poette and Reynier have investigated a comparison of non-intrusive techniques for three-dimensional mapping of multiphase flows occurring during tank sloshing (Poette &

Reynier, 2014). Considering applications, this can assure propeller feeding during flight and manoeuvres of launchers and satellites which is a major issue. Electrical and ultrasonic tomography was given particular attention as both of them have a similar nature, for instance non-invasive, non-intrusive, fast, simple and low cost to operate, and suitable for real time measurements. Later acoustic attenuation of sound wave signals was used to measure the void fraction of bubbly water–air flows, a semi-empirical model of the interaction of the sound wave with the two-phase flow was developed for the flow investigation.

Theoretical and experimental investigations on the feasibility of using acoustic resonant spectroscopy was performed by (Chen et al., 2010) to measure the gas volume fraction of liquid-gas flows. In their experimental investigation a cylindrical cavity with open ends was allowed to be immersed in transformer oil through which air was bubbled; a hydrophone was used to capture their effect on the resonant amplitude and resonant frequency of the assembly.

When the air bubbles are even below 0.1% of the size of cylindrical cavity then they are capable of causing a prominent resonant frequency shift; in this investigation this shift was observed at its maximum when the bubbles were located in the middle of the cavity. In this investigation both the resonant frequency and resonant amplitude were investigated which decreased dramatically with the increasing of gas flow rate, thus decreasing the sensitivity of the technique. The electromagnetic wave sensing technology utilizes the resonant frequencies that occur in a cylindrical cavity and monitor the changes in the permittivity of the measured phases to differentiate between the volume fractions of different fluids and flow regimes, which is proven successful (C. Oon et al., 2016; C. S. Oon et al., 2016).

A comprehensive investigation was performed on the application of pressure fluctuations of statistical analyzes for characterization and two-phase flow signals. Several

pressure transducers were used to pick-up the two-phase flow signals and were analyzed for features extraction using power spectral density to generate input parameters for the neural network (Santhosh & Roy, 2012; Xie et al., 2004; Sun & Zhang, 2007). In order to classify flow regime, other sensor signals have been utilizing statistical moment of analysis, for example radioactive images and conductance probe (Sunde et al., 2005; Hernandez et al., 2006). It is concluded that the pattern identification of flow regimes using pressure signals for real time online flow regime identification is fast enough (Xie et al., 2004; Santhosh & Roy, 2012). However, in these cases the transducers introduced are the invasive type of sensors. The requirement for a non-invasive technique for two phase flow regime classification for instance ultrasound or γ -ray is becoming important. On the basis of the review of the methods of the flow regime classification, it is shown that the techniques used earlier were empirical models or mechanistic models. The multiphase flow patterns in these investigations were identified by using equations governing the physics of the fluid developed from the mechanistic models. In this process the flow patterns are identified by using these models with the disadvantage in fact that the components of the flow are required to be examined independently (Ozbayoglu & Ozbayoglu, 2009).

Continuous wave ultrasound signals are used in Ultrasound Doppler Flow Sensors, which potentially achieve non-invasive flow velocity measurement. The existing medical ultrasound system uses the techniques of continuous wave ultrasound. This techniques utilize frequency shift phenomena representing the flow velocities that could be used to develop methods for predicting flow regimes (Übeyli & Güler, 2005). This technique can be used in application of Continuous Wave Doppler Ultrasound velocity measurement of two-phase flow in pipes. In multiphase flow measurement, (Kouamé et al., 2003) present an application of Continuous Wave Doppler Ultrasound velocity measurement to two-phase flow in pipes. They proposed the use of the frequency resolution techniques to overcome the hindrance to the velocity profile measurement by the presence of coloured

noise, which introduces a significant obstacle to the classical frequency estimators. It was observed that the Pulse echo ultrasound techniques have limited liquid velocity information due to the restriction on the maximum measurable velocity in two-phase flow measurement by using pulse wave ultrasound in the Nyquist criterion. (Evans & McDicken, 2000). It is noted that the characteristics of the reflected wave are being influenced by the shape and size of the interface of the ultrasound wave length (Murai et al., 2010).

(Abbagoni & Yeung, 2016) investigates the feasibility of using a clamp-on instrument for flow regime identification of two-phase flow using an ultrasonic Doppler sensor and Artificial Neural Network (ANN), which could record and process the ultrasonic signals reflected from the two-phase flow. A non-linear mapping between input and output variables and the cross-correlation among these variables are provided by ANNs which could be an alternative tool for automatic identification of flow patterns (Figueiredo et al., 2016). Due to fast responses and simplification the ANNs are often preferred over statistical methods of pattern recognition. (Mi et al., 2001). Moreover, the ANNs have good performance on pattern recognition due to their efficiency and learning algorithms (Jain et al., 2000). Therefore considering the flow regime classification, ANN has advantages over other analytical tools like the expert system and clustering.

Normally for two phase flow, the phase fraction in liquid is measured with a two-phase flow meter where the gas fraction is passed through a gas flow meter and the liquid through the liquid flow meter. After separate flow measurement the two streams are then recombined together to pass through a specific process. Thus the fully two-phase separation system has the advantages such as high accuracy and the suitability for all types of flow. The phase fractions in water-oil flow are commonly measured by two methods such as γ -ray and electric impedance methods in the industries. The hazard of radiation has limited the application of γ -ray method, however, the performance is stable. The electrical impedance across two capacitance plates, develops the electric impedance

technique which is a function of the ratio of the two fraction. There is a limitation of developing electric impedance technique which short circuit will occur when the high electrical conductivity material such as the water concentration in the fluid is high. With development of new methods, including microwave attenuation and infrared absorption were introduced to address the problem of the limitation of water-cut range (Qu et al., 2013).

Detail and specific data of flowing products from a well is needed for trouble free processing. Thus it is necessary to measure directly or indirectly the phase velocities, water-in-liquid ratio and liquid or gas fraction to estimate the production flow rates of oil, produced water and gases. Several companies and research organizations have introduced different measurement technologies for developing a number of MPMs to overcome this challenge. Nowadays, many challenges are yet to address, for instance the effect of fluid properties and multiphase flow regimes of phase-fraction measurements even though the MPMs are commercially used. Thus in the attempt at improving the robustness of real time measurement for crude oil production or well streams; the multiphase flow measurement is still an ongoing research topic with a motive to monitor continuous production of each individual oil well in a group of wells and to provide a low-cost MPMs solution, which is especially needed for monitoring the marginal-field production. (Li et al., 2013). In the present research for measuring the fraction of two phase water-gas stratified flow in the pipe an electromagnetic cavity sensor is used where the outer cavity is filled with air and the water is allowed to flow inside the pipe without disturbance. From the hazard point of view it has high safety features and it is a non-ionizing technique utilizing low power output and the microwave is contained in the cavity.

2.3 Multiphase flow calculation

The mass flow rate of a system is the measurement of the mass of fluid or fluids passing through a single point in a system per unit of time. The mass flow rate and the volumetric flow rate can be related as shown in equation 2.1.

$$\dot{m} = \rho \dot{V} \quad (2.1)$$

Where \dot{m} is the mass flow rate, ρ is the density of the fluid and \dot{V} is the volume flow rate.

If the volumetric flow rate is in cubic metres per second and the density is in kg per cubic metre, Equation 2.1 results in mass flow rate measured in kg per second. Other common units for measurement of mass flow rate include pounds per hours and pounds per second. Replacing the velocity in equation 2.1 with the appropriate terms from equation 2.4 can be used to calculate the mass flow rate directly.

$$\dot{m} = \rho A v \quad (2.2)$$

Where \dot{m} is the mass flow rate, ρ is the density of the fluid, A is the area and v is the velocity of the flowing fluid.

Three phases in a pipeline could be measured by different methods to express the quantities of each phase. The primary information required by the user of a three phase flow instrument are the volumetric flow rate and or mass flow rate of the oil, water and gas components in the flow (Amdal et al., 1995). Thus the direct measurements of each of these quantities are the objectives of the application of the ideal three phase flow meter. Generally, the use of a direct volumetric flow or mass flow instrument cannot measure separately each individual three phases of the flow. The alternative to direct volumetric flow rate measurement is the use of an inferential measurement technique which requires

the density, cross sectional fraction and superficial or phase velocity of each phase in order to calculate each component of the mixture volumetric and mass flow rates. Equations 2.3 and 2.4 represents the volumetric flow rates Q of each phases and the mixture flow rate respectively.

$$Q_w = A\alpha v_w; Q_o = A\beta v_o; Q_g = A\gamma v_g \quad (2.3)$$

$$Q_t = Q_w + Q_o + Q_g \quad (2.4)$$

where Q is the volumetric flow rate, the α , β and γ are the water, oil and gas phase fractions, the v_w , v_o and v_g are the superficial velocities of the water, oil and gas phases in the flowing fluid and A is the cross sectional area of the pipe. The flow velocity of one phase is defined as superficial phase velocity, assuming the phase (water, oil and gas) filled up the pipe. The phase mass flow rate M of each phase and the total mass flow rate can be calculated as:

$$M_w = Q_w \rho_w; M_o = Q_o \rho_o; M_g = Q_g \rho_g \quad (2.5)$$

$$M_t = M_w + M_o + M_g \quad (2.6)$$

where M is the mass flow rate, Q is the volumetric flow rate and ρ_w , ρ_o and ρ_g are the density of the water, oil and gas fractions.

2.4 Electromagnetic waves propagation

Figure 2.1 shows the electromagnetic waves in free space. The electric and magnetic fields oscillating in phase and perpendicular to the direction in which the wave travels, they are also oscillating perpendicular to each other and in phase. The amplitude of the electric and magnetic fields oscillate simultaneously between positive maximum and negative minimum amplitude along the propagation direction.

The electromagnetic waves in free space is presented in Figure 2.1. It is seen that the electric and magnetic fields are in phase, mutually perpendicular, and also perpendicular to the direction in which the wave travels. The electric and magnetic fields oscillate together between the highest positive and the lowest negative values along the direction of propagation. The electromagnetic waves travel at the speed of light in the free space, which relates the wavelength to the propagation frequency of the wave.

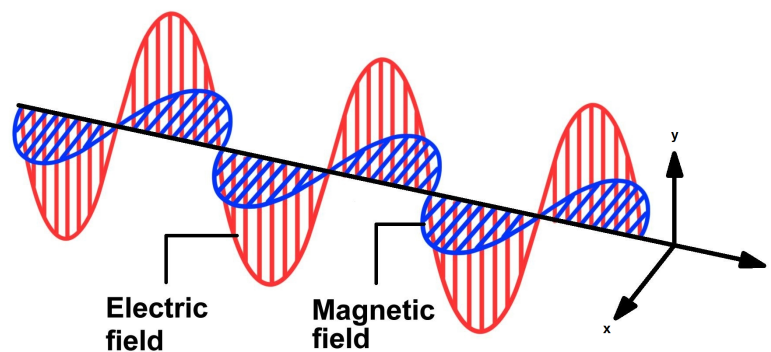

Figure 2.1. Electromagnetic waves propagation in free space. The wave propagates in the x direction, and E and H are transverse.

In communication systems radar operation the free space electromagnetic waves are widely used. In general the electromagnetic waves need to be transmitted from one location and be received at another location. The microwave sensors are designed for industrial applications, where the microwave signals have to be connected or coupled from the source to the system.

For efficient signal transmission the electromagnetic energy must be transmitted in an efficient manner from the source to the sensors with minimal attenuation. In building

the setup, waveguide and coaxial transmission line are the two commonly used microwave devices. At the microwave frequencies, each devices offer advantages and disadvantages. On the other hand, the waveguides have the advantages of high power handling capability and low loss, but have large size and narrow bandwidth. On the other hand, coaxial cable could be used advantageously for the large bandwidth and small sizes but has high attenuation and limited power handling capability. Figure 2.2 presents the shapes of rectangular and circular cross section waveguides. It is to be noted that the shape and material of each types of these devices vary according to the required applications (Connor, 1972). A cylindrical cavity resonator could be made by the use of a cylindrical waveguide with shorted ends, for installation of a microwave sensor for measuring the flowing material components in a pipeline, containing flow of water, oil and gas components.

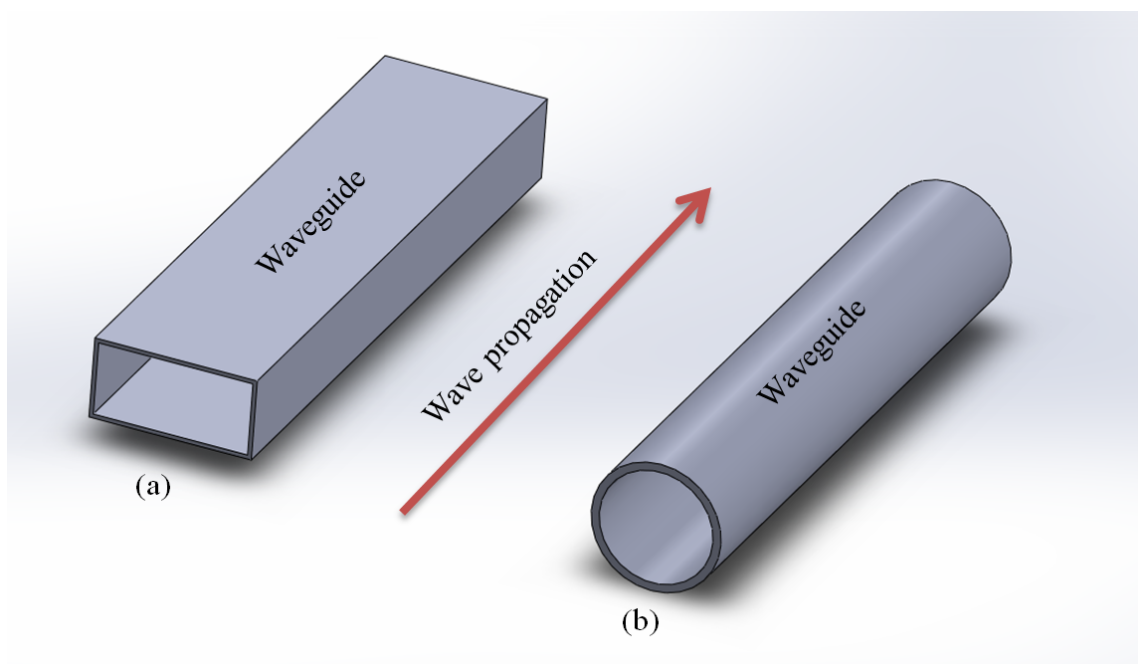

Figure 2.2. Rectangular waveguide (a) and Cylindrical waveguide (b).

2.5 Electromagnetic wave resonance cavity

The process of microwave analysis and monitoring is based on the material interaction with microwaves (Bjarnadottir et al., 2015). It could be presumed that the unique signal spectrums in the form of reflection coefficient (S_{11}) and transmission coefficient (S_{21}) based on the parameters such as conductivity and permittivity could be provided by the broadband microwave analysis of the material. Conductivity is represented by the ability of the materials to conduct electric current. On the other hand the effect of a dielectric medium on the applied electric field is the permittivity, a complex value. The material's ability determines the polarisation in response to the applied field and the mechanism of the total electric field reduction inside the material. There are two main parameters being accounted for by these properties, i.e. dielectric constant and dielectric loss of the material (Ateeq, Senouci, et al., 2012; Mason, Wylie, et al., 2014).

Dielectric constant (ϵ'): It is noted that the alternating polarisation inside the material appears when the EMW passes through the material. It has been observed that some of the energy is stored and the rest is being released slowly causing a reduction in the velocity of the wave. This phenomenon provides support in identifying materials with different dielectric constant values.

Dielectric loss (ϵ''): It determines the reduction in the applied EMW's magnitude. Under the influence of the electric field the molecules begin to rotate and produce friction causing the energy loss which reduces the magnitude of the wave.

Change of any kind in the material's concentration, percentage, type, etc. will likely change its permittivity which causes the change in the microwave response when the material interacts with the microwaves. Thus the material can be characterised by measuring this response over the range of discrete frequencies. Water is considered as a polar molecule due to the charge separation that exists between the hydrogen and oxygen atoms

and due to this it has relatively high permittivity ($\epsilon_r=81$, at 15°C). Hence, a comparatively large frequency shift could be obtained for a small change in water fraction. On the other hand, gases have low permittivity values approximately ($\epsilon_r=1$). Non-polar materials such as oil have low permittivity value ($\epsilon_r=2.2$ to 2.5) (Mason, Wylie, et al., 2014; S. Wylie et al., 2006).

Depending on the dimensions of the cavity and permittivity of the fluid flowing through the cavity the electromagnetic wave resonance cavity resonates at certain frequencies. When an electric and magnetic fields forms a standing wave then the resonance occurs. Various combinations of standing waves may exist inside the cavity. Thus various electromagnetic wave resonance modes possibly can occur inside a particular cavity. The fundamental modes for cylindrical cavities are the TM_{010} , TE_{111} and TE_{011} modes. The Transverse Magnetic (TM) Mode and the Transverse Electric (TE) Mode have electric and magnetic components respectively in the propagation direction. It is reported that when an electromagnetic wave resonance cavity oscillation is applied then each of the modes show its own resonant frequency, with a quality factor Q associated with it which is in fact inversely proportional to the power dissipated in the cavity. When fluid is exposed to EM irradiation it alters the velocity of the signal, attenuates, or reflects it.

Consider a cavity when it is excited at an appropriate EM frequency by some means for example, via a small antenna placed inside it. Depending on the dimensions of the cavity and the dielectric properties of the fluid, the resonant modes occur inside the cavity when the electric or magnetic components of the EM signal form standing waves. Equations 1 and 2 can be applied to calculate the resonant frequencies for TE_{nml} and TM_{nml} modes in a cylindrical and rectangular cavities respectively.

$$f_{nml} = \frac{c}{2\pi\sqrt{\mu_r\epsilon_r}} \left[\left(\frac{p_{nm}}{b} \right)^2 + \left(\frac{l\pi}{d} \right)^2 \right]^{\frac{1}{2}} \quad (2.7)$$

where c is the velocity of light, ϵ_r is the relative permittivity of the material, μ_r is the relative permeability of the material, b is the radius of the cavity, d is the depth of the cavity and P_{nm} is the m^{th} root of the Bessel function of the n^{th} order.

$$f_{nml} = \frac{c}{2\pi\sqrt{\mu_r\epsilon_r}} \sqrt{\left(\frac{m\lambda}{a} \right)^2 + \left(\frac{n\lambda}{b} \right)^2 + \left(\frac{l\pi}{d} \right)^2} \quad (2.8)$$

where c is the velocity of light, μ_r is the relative permeability, ϵ_r is the relative permittivity, P_{nm} is the Bessel function of the n^{th} order for the TE or TM modes of a rectangular cavity, a is the width of the cavity, b is the height of the cavity and d is the depth.

For the purposes of transmission and reception of electromagnetic energy, any number of antennas may be placed within the cavity, however one and two ports (thus, one or two antennas) cavities are involved in the most typical configurations. Using a Vector Network Analyzer (VNA) in a one port configuration it is possible to measure the power which is reflected back from the cavity as a result of microwaves interaction with the material and this phenomenon is often referred to as a S_{11} parameter/signal. However, S_{11} measurements provide most effective results only for near field or close contact. Thus the power is transmitted through the cavity in a two port configuration i.e. microwaves are inserted in the cavity to interact with the material and then the signals are received on the other end by a receiver antenna. The received signal named as S_{21} parameter/signal is then forwarded to the VNA. Since the material under test sits in the centre of the cavity, S_{21} is the better option (Mason et al., 2016).

In order to transmit the microwaves inside and to monitor its resonant behaviour a coupling structure or an antenna is required. To experience least interaction with the fields

inside, the antenna should be relatively small. A pair of loop antennas was used for the purpose of monitoring the S_{21} signal. Considering other options such as patch antenna may not be suitable because they can only measure the S_{11} (reflected signal), the recorded results of which in the previous study were not promising.

With reference to the variable permittivity inside the pipeline and the air in the outer cavity, the resonant modes of the cavity do not change all at the same rate with respect to the permittivity, as they would if the entire cavity were filled by a homogeneous material. It has been observed that some modes would interact more with the central portion of the cavity containing the pipe so it would be more sensitive to changes in the pipeline permittivity than that of other modes.

2.6 Boundary conditions in waveguides

The electromagnetic waves propagation inside a waveguide or cavity resonators different from the electromagnetic waves propagation in free space. The waveguide confines the electromagnetic wave propagation inside a metallic enclosure, it has physical limits. In order to enable the energy to travel through a waveguide or cavity resonator, there are two boundary conditions. The first boundary condition is the electric field has to be perpendicular to the metallic conductor as shown in Figure 2.3. In other word the electric field cannot exist parallel to a metallic conductor, as illustrated in Figure 2.4.

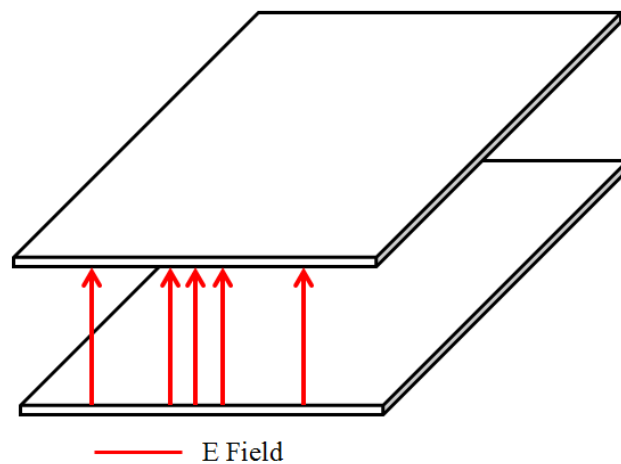

Figure 2.3. E field boundary condition. It meets boundary conditions.

The second boundary condition refers to figure 2.5 where an alternating magnetic field exists in an enclosure where it forms closed loops, is perpendicular to the electric field and is parallel to the metallic conductors.

E field induces current flow and that produces an H field, where both the fields always coexist at the same time inside a waveguide or cavity resonators. In other words, the system satisfies both the boundary conditions simultaneously, since neither field can exist alone.

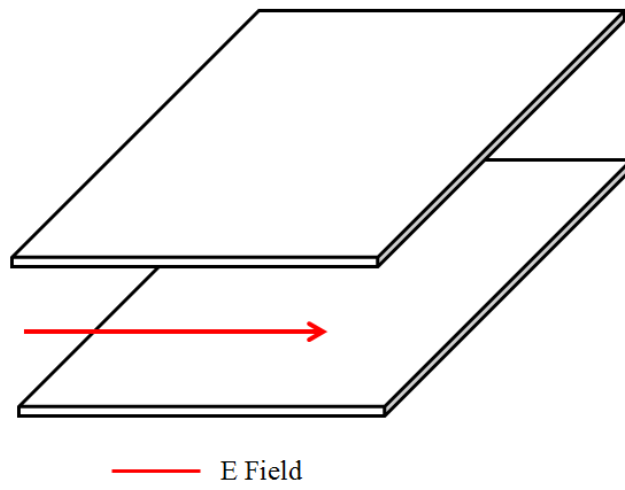

Figure 2.4. E field boundary condition. It does not meet boundary conditions.

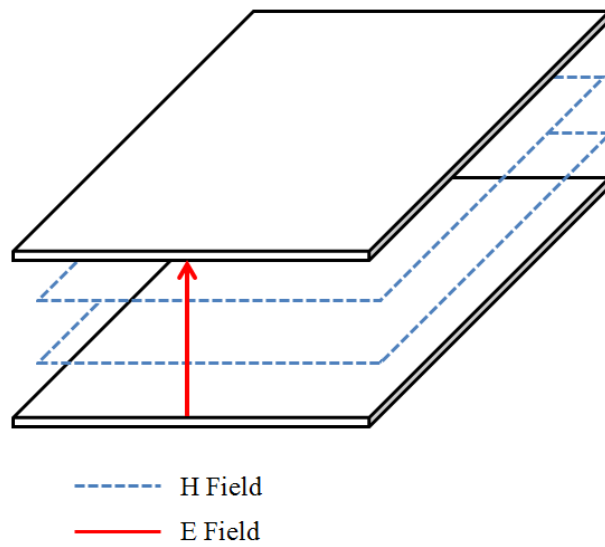

Figure 2.5. H field meets the boundary conditions.

2.7 Microwaves sensor basic

In the wake of the industrial revolution, the automation of applied processes has come up with an incredible need for sensors. Different problems are being solved by different types of sensors (Thorn et al., 1997). The electromagnetic wave sensors operating at microwave frequencies are based on the principle of interaction of signals with the medium material. Hence the type of interaction generated could be in the form of amplitude attenuation, phase shift as reported by some researchers (Nyfors & Vainikainen, 1989). Depending upon the measurement technique and interactions, the Microwave sensors can be divided into groups. Research on resonance cavity or waveguide sensors, transmission sensors, reflection sensors, etc. are used for measuring water, oil and gas flowing in a pipe (Nyfors & Vainikainen, 1989). Another group of sensors are the radiometers sensor, radar sensor and topographic sensor developed to measure physical quantities for instance solid material properties, movement, shape and distance. The measurement of material with microwave sensors are based on the relative permittivity and permeability which are completely determined by the interaction between microwave signal and the medium of material. Equations 2.9 and 2.10 represent the relative permittivity and relative permeability respectively.

$$\epsilon_r = \epsilon' - j\epsilon'' \quad (2.9)$$

Where ϵ' is the real part of the permittivity, j is the imaginary unit and ϵ'' is the imaginary part of the permittivity.

$$\mu_r = \mu' - j\mu'' \quad (2.10)$$

Where μ' is the real part of the permeability, j is the imaginary unit and μ'' is the imaginary part of the permeability.

The real part of the relative permittivity has been specifically considered in this thesis as the interaction (resonant frequency) effect of the microwave signal, unless otherwise stated, $\epsilon''=0$, and $\mu_r=1$. As different materials have different permittivity, a mixture of permittivity depends on the relatively large component of permittivity as well. In other words, depending upon the permittivity of the mixed materials, the measurement of the applied microwave properties can provide information about the material taken under investigation. Hence, in general the total permittivity for two components is 100% for a simple case. In this case, if there is one unknown permittivity of the components then it could be possible to evaluate from the total and the known permittivities of the composite material. Therefore, it is possible to deduce the composition using one measurement which is the resonant frequency. When there are more than two components in the mixture, the identification become complicated, for instance the mixture of water, oil and gas mixture. For this type of flow measurement the multiphase flow sensor or three phase meter is needed, where different kinds of technology is used to detect or measure the components of a mixture in a three phase flow system (Thorn et al., 1997; Kolev, 2005).

The simplicity of the process is the advantage of the microwave sensor, but the sensitivity of the reflections in many different components in the system pose the main problem, for example the interaction between the material and electromagnetic wave depends on the flow regime and the dielectric windows. There are ripples formed on the frequency response in the system caused by the reflections and the amplitude is much more affected than the phase. Measuring only one microwave parameter by the sensor could provide higher accuracy, it can be achieved better by using measuring the signal phase shift measurement compare to the amplitude of attenuation measurement (Klein, 1981).

When the small losses fluid is flowing inside the pipe compare to the reflections from the pipe walls, it will also experience strong effect on both the phase and the amplitude (Brodwin & Benway, 1980). The errors are substantial if the measurement is taken on

one single frequency as it moves the cut off frequency of the applied frequency mode.

2.8 Microwave Waveguides

Guided electromagnetic energy at microwave frequencies can be obtained by waveguides or resonance cavities which can be recognized as hollow conducting pipes. Copper, brass, or aluminium, are used to make waveguides and they can be employed to construct either rectangular or cylindrical cross section. In this case the lower operating frequency limit is governed by the physical dimensions of the waveguides.

A single conductor constitutes the waveguides; therefore, they can only support transverse electric TE and transverse magnetic TM waves, which are also characterized by the longitudinal magnetic or electric field components respectively. This type of transmission method has the drawback of the relation between the physical size of the waveguide and the wavelength of the electromagnetic wave (Colline, 1992). The relationship requirement reveals that the width of a waveguide must be approximately half of the wavelength at the frequency of the wave to be transported. Thus a waveguide for use at 1 MHz would be about 150 metres wide. Thus it has become impractical to use waveguides at low frequencies. Figures 2.6 and 2.7 predicts, the cylindrical and the rectangular waveguides respectively with internal dimensions.

TE and TM waves but not the TEM waves could be propagated by the rectangular and cylindrical waveguides. This phenomenon refers to the fact that a unique voltage cannot be defined since there is only one conductor. Thus various possible solutions for both the TE and TM waves are available; so the subscripts are used to complete the description of the field pattern in the mode to be transmitted. In case of the rectangular waveguide, the number of half waves in the a dimension represent the first subscript and the number of half waves in the b dimension represent the second subscript. Figure 2.8 depicts the TE_{10} mode field configurations in the rectangular waveguide. The first subscript is considered 1 as there is only one half wave pattern across the, a dimension.

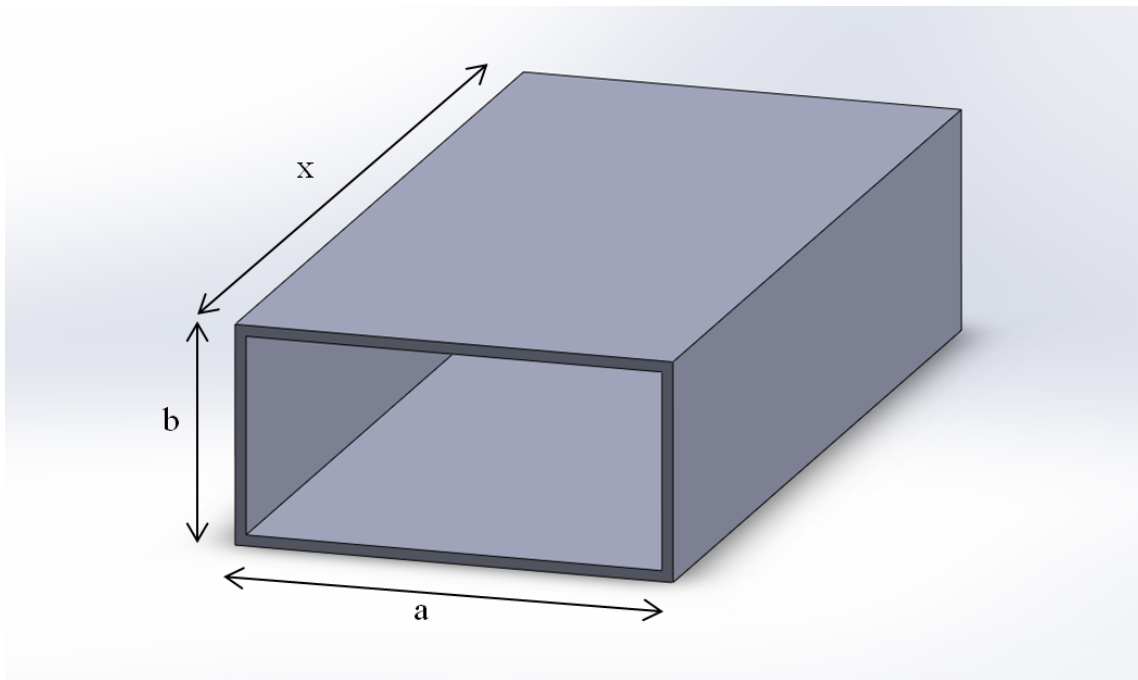

Figure 2.6. Rectangular waveguide with internal dimension a and b.

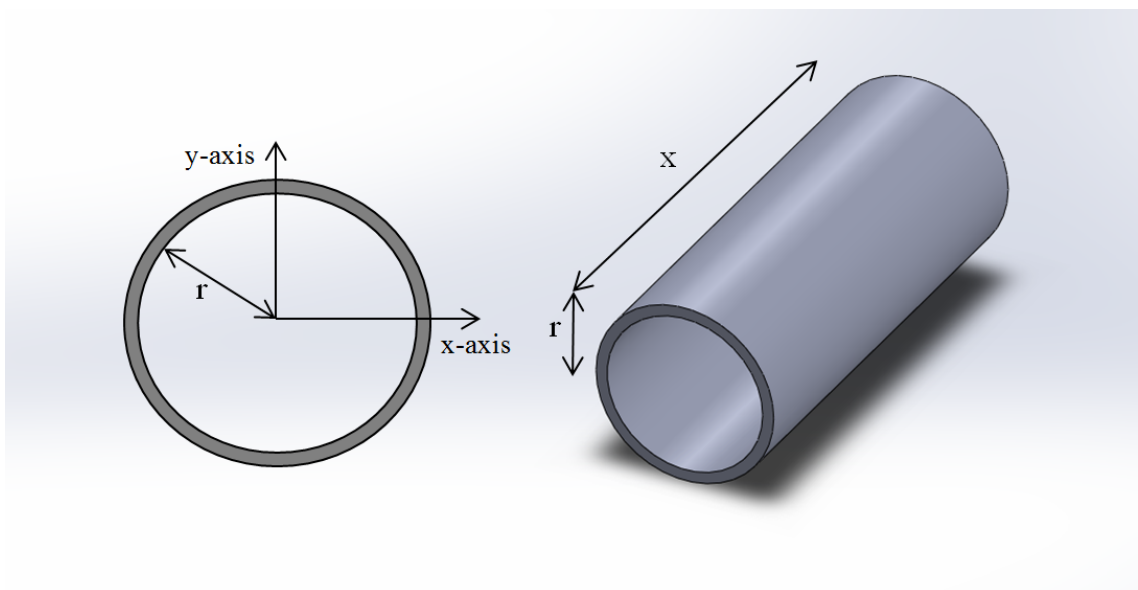

Figure 2.7. Cylindrical waveguide with inner radius, r.

Across the, b dimension there are no E-field patterns as well, so the second subscript could be denoted 0. However, TE_{10} represents the complete mode description of the dominant mode in rectangular waveguides.

The subscripts have a different meaning for a circular waveguide. The first subscript represents the number of full-wave around the circumference of the waveguide. The second subscript represent the number of half-wave patterns across the diameter. In

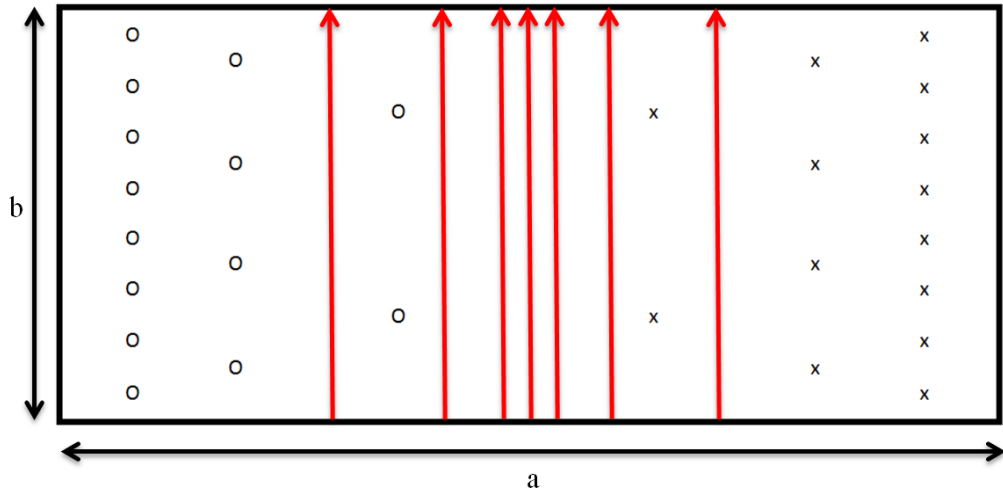

Figure 2.8. (TE_{10}) mode field configurations in rectangular waveguide.

the circular waveguide shown in Figure 2.9, it could be reported that the E field is perpendicular to the length of the waveguide with no E lines parallel to the direction of wave propagation.

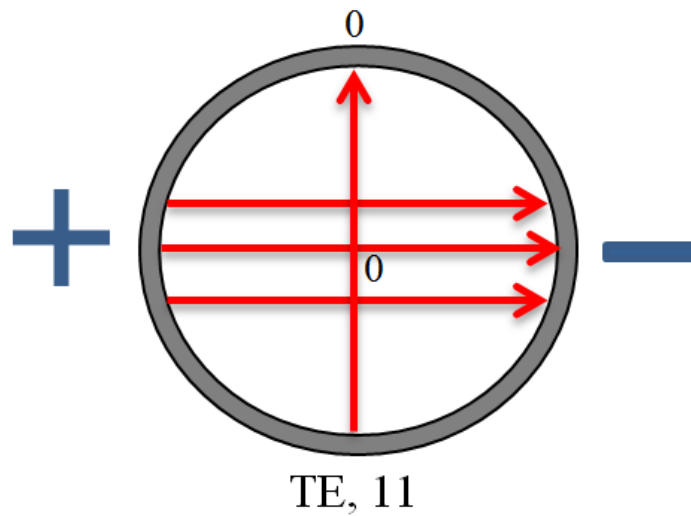

Figure 2.9. Dominate mode (TE_{11}) field configuration in circular waveguide.

Therefore, while operating in the TE mode it must be classified. If the E line pattern is following a counter clockwise direction starting from the top, the E lines move from zero, through maximum positive or the tail of arrows (9 o'clock) and then back to zero, it continues through the maximum negative or the head of arrows (3 o'clock), and returns

back to zero again. Here the first subscript is 1 because this is one full wave. For the horizontal direction across the diameter, the E lines go from zero through maximum and then back to zero, making a half wave. It is represented by 1 for the second subscript. Therefore, TE_{11} is used to describe the dominant mode in circular waveguides. A similar procedure can be used to identify different modes for both circular and rectangular waveguides.

Based on the desired mode of operation and the frequencies the dimension for a waveguide is chosen to be operated at a given wavelength. It is noted that the set dimensions are based on the cut off frequency in waveguide standard design of the fundamental mode. The cut off frequency of a waveguide is defined as the lowest frequency below which the energy will not radiate in a waveguide. In that stage a lower frequency will attenuate rather than propagating.

2.9 Microwave sensors application/potential

Sensors operating within microwave frequencies or microwaves sensors are broadly utilized in commercial and industrial sectors; they are also widely studied by researches around the world. The use of microwave sensor include water quality monitoring (Korostynska, Ortoneda-Pedrola, et al., 2014; Korostynska et al., 2013; Korostynska, Mason, Ortoneda-Pedrola, & Al-Shammaa, 2014), medical applications (Lu et al., 2009; Dei et al., 2009; Fok et al., 2015; Korostynska, Mason, & Al-Shamma'a, 2014; Blakey et al., 2013; Mason et al., 2013) and structural analysis (Adous et al., 2006; Ali et al., 2015). Quality classification of fresh (Castro-Giráldez, Aristoy, et al., 2010; Castro-Giráldez, Botella, et al., 2010) and cured meats (Fulladosa et al., 2013; Bjarnadottir et al., 2015) using microwave sensors is also extensively studied.

One researcher from Liverpool John Moores University, O. Korostynska proposed that no currently available sensor system today can fully address the customers' requirements. The sensor is required to detect the composition of water solutions to the desired resolution in real time, plus there is the need for system mobility and cost effectiveness. Consequently, novel real-time monitoring methods are essential. One method highly capable of meeting these requirements is based on the microwave sensing technology (Korostynska, Ortoneda-Pedrola, et al., 2014).

Microwave sensors offer robust and real-time non-invasive method of materials analysis. The researchers have shown that the sensor can take on many physical forms, including planar structures (Korostynska et al., 2013; Mason et al., 2013), fluidic devices (Blakey et al., 2013) and resonant cavities (Mason, Korostynska, et al., 2014), It is highly adaptable to different working environment and versatile sensing applications. Moreover, it is fairly inexpensive to generate and detect microwave signals using currently available technology; it is featured in the many wireless communications devices for example

tablets, portable computers and smart phones. Microwave sensors are particularly attractive for the meat industry, given the needs for high-resolution drip loss detection with low cost devices, which is expensive using the current technologies like γ -ray and X-ray. In addition, the microwave technique is non-ionizing, uses less power than modern wireless communication devices which is no more than 10 mW. Consequently, it is considered safe to be used in food production facilities without the risk of radiation leaks (Adous et al., 2006).

Ateeq, Senouci, et al. (2012) studied the optimum detection of bitumen using the frequency range between 0.25 to 3.20 GHz. According to his study, the higher frequency range can be used depending upon the microwave response and physical properties of the materials. Microwave can penetrate dielectric materials, for example, glass, plastics, composite materials (a few centimetres thick) and ceramics (Wellock & Walmsley, 2004). Therefore, interaction of Microwave with bitumen samples needs the thorough understanding of both its thermal and physical properties. It is thought best to use cavity resonators which can contain the whole sample for analysis (Scheffler, 2004).

Recently in the water treatment industry, many technologies have been developed to detect nutrient level in real time to avoid environmental pollution and hefty fine by the authority. Al-Dasoqi uses two cavity microwave sensor to detect high and low concentration of Phosphorus and Nitrogen in waste water treatment plant. To detect high concentration liquid (≥ 24 mg/L of dissolved phosphorus), the sample was introduced into the centre of the cylindrical cavity in 15ml Polypropylene tubes. For low concentration liquid detection (≥ 5 mg/L of phosphorus and ≥ 2 mg/L of nitrogen), the sample was introduced into the centre of rectangular cavity in Nuclear Magnetic Resonance (NMR) tube. The combination of these two cavities sensor solved the high and low concentrate nutrient detection. On the other hand, the major disadvantage is that two different sampling tubes have to be used for the detection. The samples also have to be physically taken by human

and put inside the sampling tubes which require trained personal to avoid contamination and error during the process (Al-Dasoqi, 2012).

Mason, Korostynska, et al. (2014) proposed a rapid microwave detection method based on the interaction of electromagnetic waves and a material. Microwaves are common in sensing applications such as waste water monitoring (Al-Dasoqi et al., 2011) and oil pipeline monitoring (S. R. Wylie et al., 2006; Al-Hajeri et al., 2009) because of their response to the different dielectric properties of materials. In another study, activated carbons filter ages over time due to the exposure to atmospheric conditions and reaction with various gases including toxic ones. Consequently, the amount of the activated carbon will decline, hence the dielectric properties of the material changes. This phenomenon can be detected through measurement of microwave power transmitted through and reflected from an activated carbon sample. Microwave measurement methods have been demonstrated to offer excellent speed and precision; moreover, the applications of it are versatile enough to adapt to a wide range of filter sizes and configurations.

Microwaves are widely utilized for material characterization because the electromagnetic wave transmitted through or reflected by a medium highly depends on the dielectric properties of the material, and the electromagnetic wave easily propagates through low-loss dielectrics material (Mukhopadhyay et al., 2013). The signal is distorted when interacting with the medium, and this appears in the form of compression or broadening of the pulse, specifically water, which reaches its maximum at or approximate to the resonant frequencies (Georgiadou et al., 2006).

(Kapilevich & Litvak, 2007) reported that a cavity resonator utilized microwave for accurate measurements of organic (alcohol, sugar) and inorganic ($KMnO_4$, $NaCl$) water solutions concentrations. Particularly, the resolution of the sensor to detect $NaCl$ was $0.4 \text{ dB (mgml}^{-1}\text{)}^{-1}$ for concentration between 0–1%. The concentrations of other water solutions were able to be detected as well, however, its resolution are highly depends on

the type of chemical.

Planar printed patterns electromagnetic sensors have been getting attention in recent years due to their, flat profile, low weight and versatility. It can be designed to suit specific applications, addition to cost-efficiency and reliability. The manufacturing process is easy and common similar to that of the printed circuit board production. By changing the micro-strip line feed configuration, their impedance can be matched to the input line (Korostynska et al., 2013).

A broadband 433MHz bow-tie antenna is conducted by Abdou et al. (2013) in air and water with wireless sensor. The antennas are connected to transceivers and form a Wireless Sensor Network underwater application. The bow-tie antenna was designed and constructed in laboratory with the aid of simulations. Many experiments were conducted to avoid airborne transmission using isolated transmitter from electronics. The bow-tie antenna (using 433MHz frequency) has proven its feasibility for underwater use.

Communication via electromagnetic waves has been marginalized due to attenuation at high frequencies. The velocity of electromagnetic wave is $3 \times 10^7 m/s$, it offers many benefits over conventional acoustic methods, better transmission across boundaries and data rate including bandwidth. Attenuation is the major hindrance in underwater radio wave propagation. But (Abdou, Shaw, Cullen, et al., 2011) demonstrated theoretically and experimentally that electromagnetic wave can propagate in the water at certain distances in relatively low frequency bands. In order to deploy underwater Wireless Sensor Network electromagnetic wave communications, many experiments were conducted by (Abdou, Shaw, Mason, et al., 2011) using custom made radio transceivers. Loop antennas were used in (Abdou et al., 2012), (Shaw et al., 2006) and other researchers due to their directional behaviour, they are highly sensitive to magnetic fields thus they are more suitable for seawater.

Microwave sensor technology even though in its early stages has been utilized in

many research and industrial applications including the water industry or multiphase flow monitoring (S. Wylie et al., 2006; C. Oon et al., 2016), glucose concentration monitoring (Bababjanyan et al., 2010), food industry (Muradov et al., 2016) water level measurements, characterisation of construction materials and material moisture contents (Ateeq, Senouci, et al., 2012; Ateeq, Wylie, et al., 2012) and healthcare industry (Blakey et al., 2012).

2.10 Current available electromagnetic wave sensor

The electromagnetic wave sensors operating at microwave frequencies are based on the principle of interaction of signals with the medium material. Hence the type of interaction generated could be in the form of amplitude attenuation or phase shift, depending upon the measurement technique and interactions. There are phase shift sensor, attenuation sensor, transmission sensor, reflection sensors, etc. used for measuring water, oil and gas in a flowing pipe.

2.10.1 Attenuation sensor

On the other hand, based on an open ends hollow cavity or waveguide (Hasted, 1973; Basrawi et al., 1999) the Roxar phase component sensor was manufactured. In this sensor the electromagnetic waves are transmitted into a particular flowing mixture which at a characteristic frequency, resonates to produce distinct peak amplitude. The generated peak is directly proportional to and corresponds with the phase fraction or component, e. g. water content (Gaisford, 2001). It can also be said that the mixture components produce different and distinct peak amplitudes at the resonance state. This difference appears due to their different dielectric constants. On the other hand, the developed peaks are captured and translated directly as a phase component measurement in the mixture. This sensor is only accurate for low loss media measurement, which is the major limitation in this case. A loss in signal simply means there is oil in the fluid. This is due to the fact that the water in the fluid absorbs energy too fast for resonance to occur (Basrawi et al., 1999; Gaisford, 2001).

2.10.2 Phase shift sensor

Based on the measurement of phase shifts and a microwave resonance cavity of coaxial configuration (waveguide), the electromagnetic wave sensor Agar is commercially used (Scott et al., 1993; Mehdizadeh et al., 1995). As a measure of the component in a mixture it can measure the phase shift of the applied electromagnetic wave signal as per permittivity of the constituents of the mixture. Here the transmitting signal is applied from one side and the transmitted signal is received by two antennas at the other side at a distance from the source antenna. Then the phase shift between the received signals is used for calculation of (with regard to the transmitted signal) the difference as a measure of the phase components in the mixture.

The damping effect of electromagnetic waves signals at microwave frequency by water and oil for various measurement cause the different degree of attenuation. For water medium the attenuation of microwave amplitude is quite substantial (Scott et al., 1993). The energy loss during transmitting and receiving of microwave signal between transmitter and receiver is clearly observed.

The major problem faced using this technique is the fluid is in contact with the transmitter which dominates the readings (Agar, 1992). If the fluid is immiscible as it is with water-oil mixture then the effect on microwave signal is serious. False reading could appear in this system because of the uneven distribution of the fluid particles result in the energy loss and phase change. In this system the transmitter and the receivers are required to intrude into the flow channel (Mehdizadeh et al., 1995; Agar, 1992). The drawback of this method is wear and tears and replacement of the antennas from time to time in this system. Also, the antenna surface needs to be cleaned due to fluid clogged which incurred higher operational cost and downtime. As this approach required intensive maintenance, it would not be applicable in a remote environment.

2.10.3 Transmission sensor

Figure 2.10. depicts a transmission sensor. This sensor is built of two dielectric windows fitted symmetrically on either sides of a metal pipe with a transmitting antenna and a receiving antenna. The material flowing in the pipeline between the antennas (Klein, 1981) is being penetrated by the microwave signals. The amplitude and the frequency shift of the signal are affected by the permittivity of the flowing fluid or liquids. The transmission sensor is easy to construct, however, it is highly sensitive to the flow regime. Also, the antenna in contact with the flowing liquid may cause rust and deposition on the antenna.

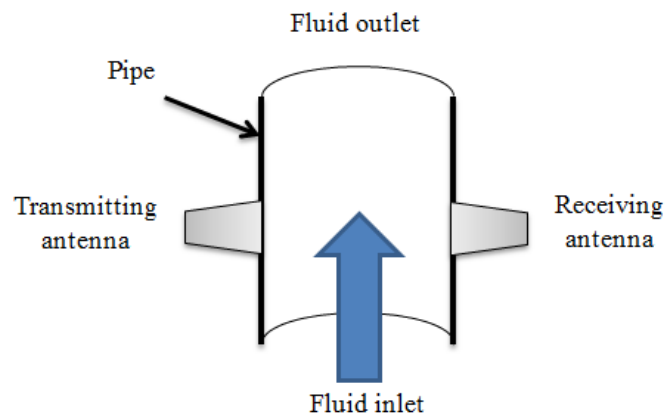

Figure 2.10. The basic geometrical configuration of a transmission sensor.

2.10.4 Reflection sensor

Measuring the reflection coefficient for a wave reflected at the end of a transmission line is the basic of a reflection sensor. In this system the fringing field at the end gets in contact with the flowing material that affects the magnitude and phase of the reflection coefficient (Stuchly & Stuchly, 1999; Colpitts et al., 1992).

The open ended coaxial sensor measures with the fringing field at the front surface of the sensor. In this system a small fraction of the mass flowing in the pipe could be measured. Generally, the reflection sensor is not suitable for applications in the oil and gas industry, but it may be suitable for emulsions of water and oil with little liquid drop size as the presence of a small volume affects the measurement.

2.11 Summary

Microwave spectroscopy utilizes the transmission, absorption, reflection and scattering of electromagnetic waves to study and analyze samples, molecules and materials. Since microwave (operating frequency between 300MHz to 300GHz) are highly related to the changes of the molecule's rotational energy, the geometrical structure of the molecule plays an important role. Thus, microwave spectroscopy can be used to identify the rotational spectra of the molecules acquired from the interaction between microwave with molecules of liquid, gas, solid and suspension. Higher frequency detection can be used depending on the material responses to electromagnetic waves interaction and its physical properties. Dielectric materials are penetrable by electromagnetic waves, such as ceramics, composite materials, plastics and glass up to a few centimetres thick. Thus, the interaction between the samples and electromagnetic waves needs the understanding and knowledge of the material's thermal and physical properties. According to the literature review, it is best to utilize cavity resonators in which the fluids or sample can pass through the center of the cavity for analysis and measurement.

The current research work uses electromagnetic waves sensors, operating at microwave frequency to measure the phase components (for instance oil and water mixture) are based on microwave resonant cavity or waveguide technologies. When microwave signals are applied at a characteristic frequency to a mixture of flow in a pipeline then the resonance and properties of these signals (amplitude or phase shift) are affected by the flow permittivity and then it could be measured and used as an estimate of phase components in the mixture.

CHAPTER 3: METHODOLOGY

3.1 Introduction

The previous chapter explained the details of current available technology of multiphase flow sensors and the theory of microwave sensors. This chapter will discuss the methodology on how to use this technology for the non-invasive sensing of two phase flow. A series of experiments is planned and conducted to validate the usability of the design. A novel approach is also introduced to solve the low permittivity detection. A flow chat is included to briefly explain the process of design and experiment. The figure 3.1 shows the flow chat for electromagnetic wave cavity sensor development.

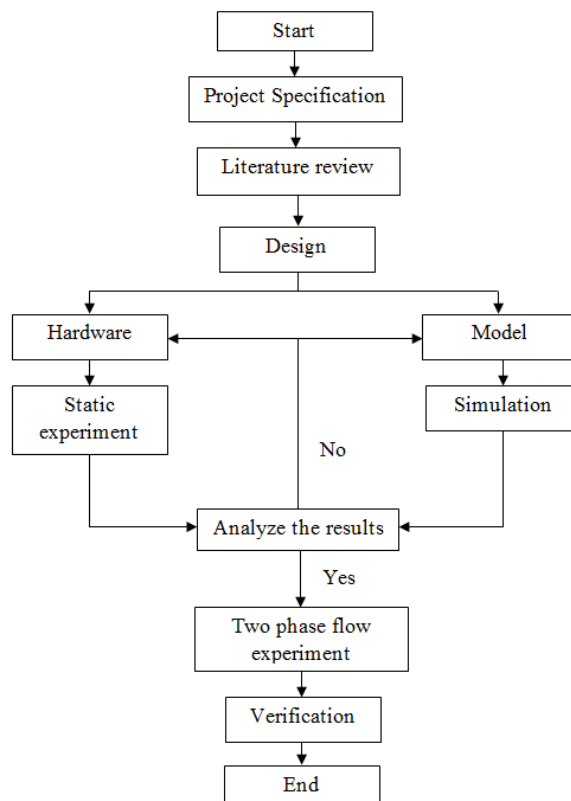

Figure 3.1. Electromagnetic wave cavity sensor development flow chat

3.2 Experimental setup

In this experimental study, the cylindrical cavity utilized had its diameter larger than the pipeline and is open at both ends. This design allowed the pipeline to appear continuous. The schematic diagram of the cavity along with the pipeline and the embedded coupling structures/antennas is shown in Figure 3.2. The non-intrusive design of the cavity allowed the antennas to be placed at the appropriate locations on the cavity. It also enabled the excitation of the resonant frequency for the analysis of water-air and water-oil fractions in the pipeline. The design of the cavity allowed the pipeline to be kept isolated and the antennas to be protected from the fluid. Although, the technique is robust and instantaneous, the limitation of this electromagnetic cavity sensor is that the pipe carrying the fluid should be non-conductive material to allow the penetration of microwaves through the pipe at higher frequencies.

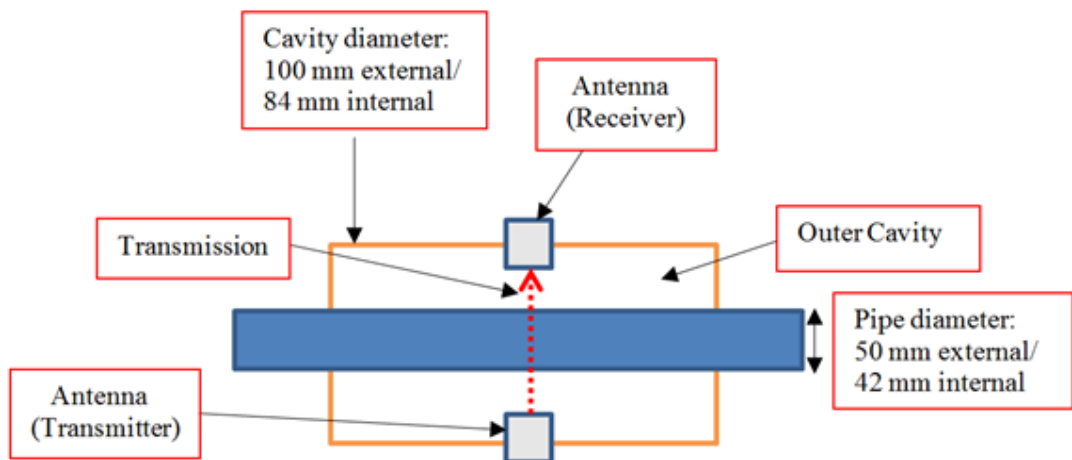

Figure 3.2. Schematic diagram of the resonant cavity with pipeline

3.2.1 Microwave cavity

The resonant cavity used is shown in Figure 3.3. It has an outer radius of 50 mm and a length of = 300 mm. The PVC pipeline inside the cavity has an outer radius of 25 mm. The outer cavity is made from brass. Antennas are attached to each side of the cavity as shown in Figure 3.3.

The non-intrusive design of the cavity enabled the outer pipe to be kept empty and the inner pipe filled with water-air and/or water-oil fractions. The mode at which measurements were taken only interacted with the central portion of the cavity where the PVC pipe sits and was sensitive to the permittivity changes in the pipe due to change in the fractions.

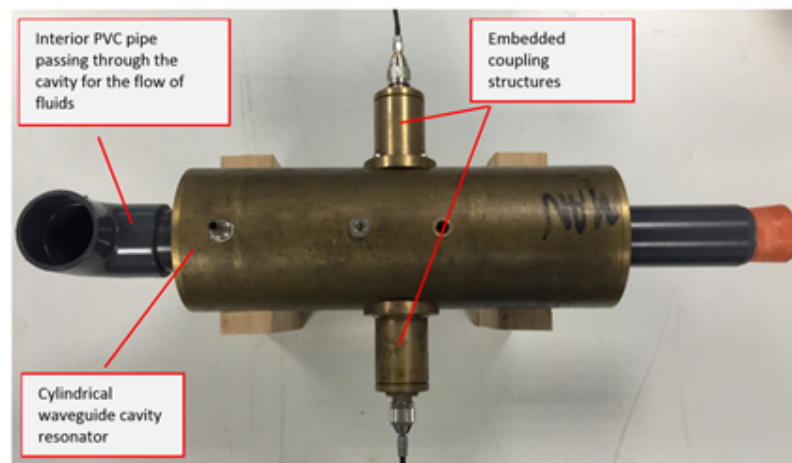

Figure 3.3. Cylindrical microwave cavity resonator with embedded antennas

3.2.2 Static experiment and real time measurement

The experimental setup of the measurement system is shown in Figure 3.4. The setup consists of Rodhe and Schwarz Vector Network Analyzer (VNA) model ZVL-6 with a frequency range of 9 kHz -6 GHz, an online data processing computer with LabVIEW display to capture and analyze the data, the cylindrical resonant cavity along with loop antennas embedded on both sides, a PVC pipe passing through the cavity, cables and connectors. The input power used to launch the microwave inside the cavity was 0 dBm and 4000 data points were selected for each measurement. Two antennas were used to monitor the resonant frequencies so that the measurements can be obtained.

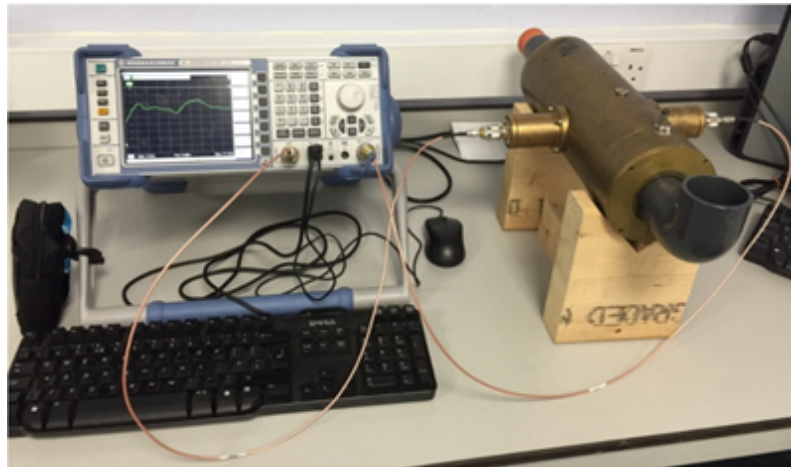

Figure 3.4. Experimental setup of the measurement system showing the cavity, VNA, cables and connectors

The experiment is conducted by measuring the volume of fully filled water in the pipe which is 740ml. Water was then added to the empty pipe in increments of 148ml of water, each representing a 20% increase in water fraction. The data was captured during testing of the prototype sensor, when the percentages volume of water-gas mixtures increased from 0-100% in the pipeline.

3.3 Labview software application

A Labview software application was designed to enable the system to display real time results and an equation was introduced in the data processing. Figure 3.5 shows the system front panel offline screen shots for real time water or air fraction detection.

The research team at RFM Group of Liverpool John Moores University had previously attempted the use of Electromagnetic Wave sensors for measuring and monitoring purposes. A data base is created to store all data collected and compared with the real time measurement in order to obtain the results. The drawback of this approach is a huge data storage space and a large amount of iteration is needed to perform the task. An innovative approach to overcome these problems is by modelling all the data collected using a mathematical interpretation. Instead of storing all the data, the new approach identifies the interested points and represents them using a mathematical equation. The new approach uses shorter time, less computational power and substantially reduces the error of comparing the stored data and newly obtained data.

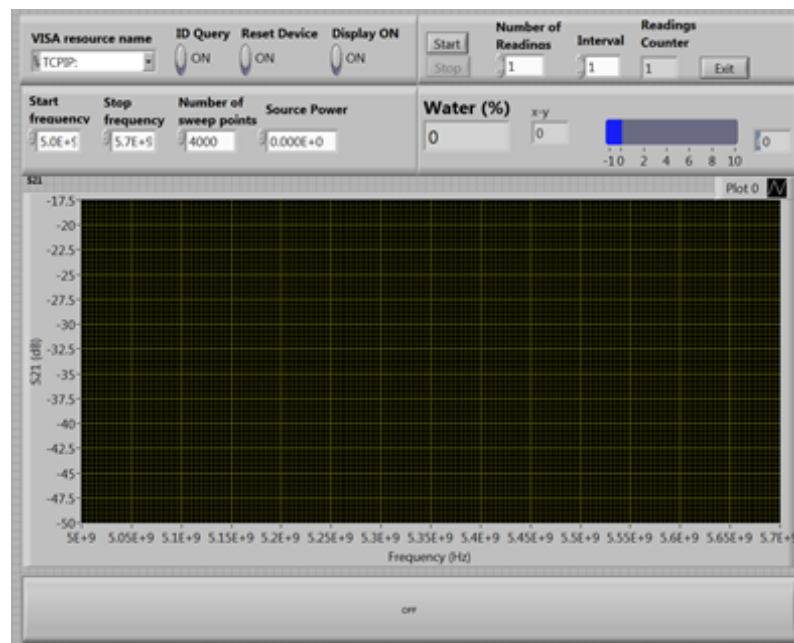

Figure 3.5. Offline front panel display

3.4 Samples tested and measurements procedure

For the first phase of the research, only static water-air and water-oil were tested. The analysis of the temperature impact on the water sample was used to establish and demonstrate the independence of the temperature of water on the microwave frequency response. The consistent output of this technique to the temperature change was useful to demonstrate the effectiveness of the microwave analysis technique not only at the room but also at higher temperatures. This study could be extended further in the future work to include two phase fractions and the temperature impact on them. The samples analyzed for the percentage of the volume fraction between water-air and water-oil is shown in Table 3.1.

Table 3.1. List of two phase system of water-air and water-oil tested for the monitoring and analysis of the volume fractions

Sample type	Volume fraction (%)		Temperature (°C)
	Air fraction	Water fraction	
water-air (two phase)	0	100	20
	20	80	20
	40	60	20
	60	40	20
	80	20	20
	100	0	20
Sample type	Oil fraction	Water fraction	Temperature (°C)
water-oil (two phase)	0	100	20
	20	80	20
	40	60	20
	60	40	20
	80	20	20
	100	0	20

The sample of the fractions of water-air and water-oil were analyzed at a constant room temperature of 20°C. This was maintained easily because the tests were carried out in a temperature controlled environment with a thermostat fitted in the room to constantly monitor and control the temperature.

The measurements of the change in the volume fraction of two phase systems were first conducted over the full range of the spectrum between 9 kHz and 6 GHz. However, it

was found that the frequency below 5 GHz did not correspond to the changes in percentage of water. The results of the frequency response were also not consistent with change in the fraction percentage. The frequencies above 5.7 GHz were eliminated because of the ambiguous microwave response as well as to avoid the multi modes and complexities in the data analysis in the later stage. The measurements were taken between 5-5.7 GHz with the cylindrical cavity operating in $_{124}$ mode. The experimentation was conducted by measuring the volume fraction of water required to fill the PVC pipe that was equal to 740 ml. The volume was then divided by 5 to get the amount of volume fraction increase each time in the pipe which equalled 148 ml. The measurement was first taken with the empty pipe, i.e. filled with 100% of air. Afterwards, as worked out, each 148ml of water was added into the pipe representing 20% increase in the water fraction and in proportion 20% decrease in the air fraction. The data was captured and recorded in real-time using LabVIEW program designed to display the microwave response curves. The percentage of the volume of water was increased from 0-100% in the pipeline. Likewise, a similar procedure was repeated with water-oil volume fractions with oil starting at 0% and water at 100%, i.e. 740 ml. The percentage of water was decreased and oil increased by 20% and measurements taken for each of the percentage increase till the pipe was filled with 100% oil. The measurements were repeated five times to check the consistency in the response pattern. The repetition of the measurements of fractions along with the standard deviation were calculated.

The figure 3.6 flow chat below shows the working principle of the electromagnetic microwave sensor for two phase flow detection.

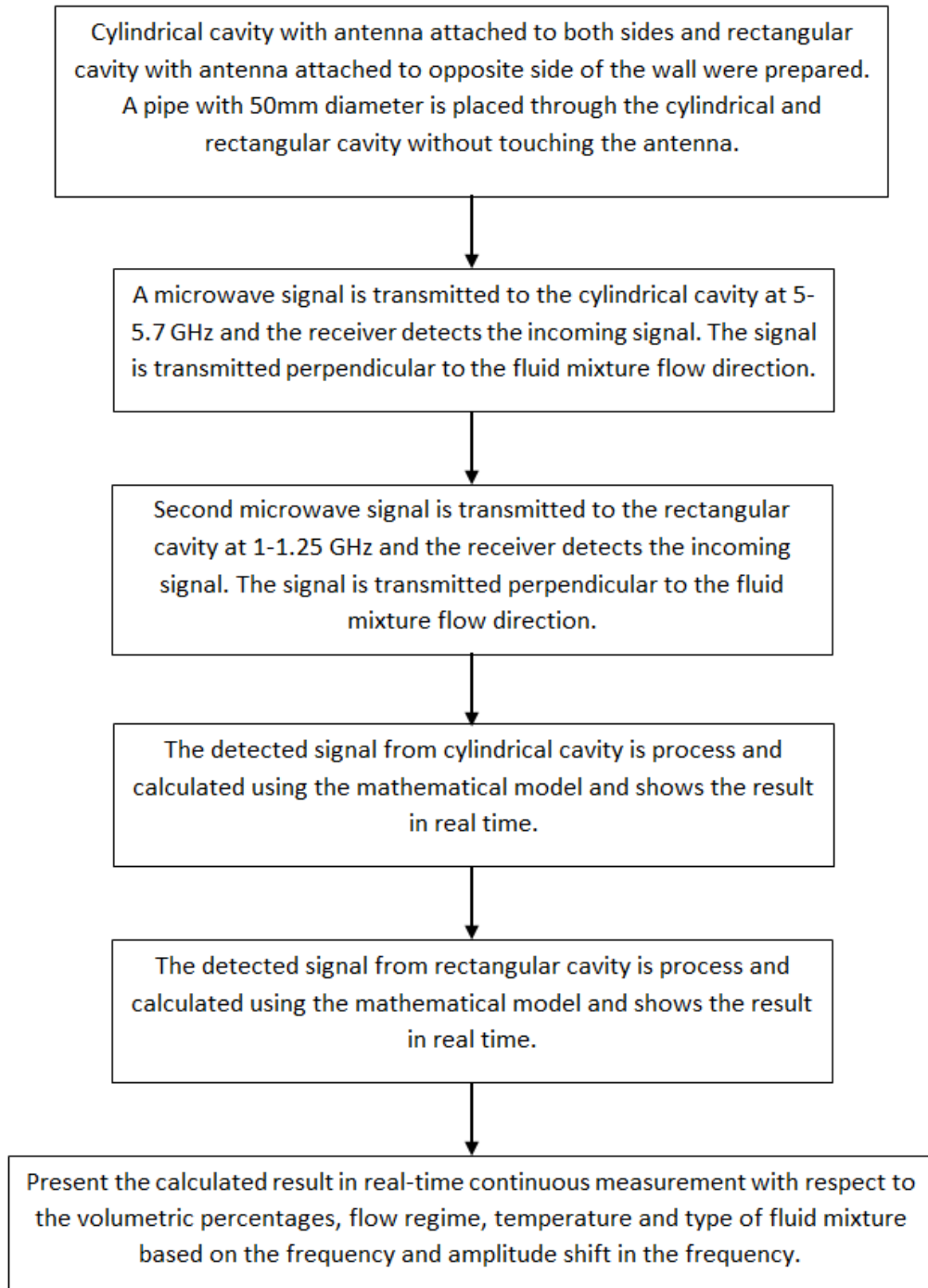

Figure 3.6. The working principle of the electromagnetic microwave sensor flow chat

3.5 Temperature effect study

In the temperature dependent study of water, the pipe was filled with 100% of boiling water and the microwave response was captured and recorded. The temperature of water was monitored and recorded using a laboratory thermometer. The accuracy of thermometers is 0.5°C. The interval of the data recording was set manually corresponding to the temperature drop (approximately every 10°C). This was done because the permittivity of polar materials, including water, is a function of temperature. The permittivity of water reduces with temperature, so resonant modes will occur at higher frequencies when the water is hot. As the changing permittivity causes the modes to change frequency at different rates, however, they will overlap and this causes some frequency ranges to appear to be more (or less) sensitive to temperature than the individual modes would be. The sample of water tested along with the temperature parameter is shown in Table 3.2.

Table 3.2. Analysis of the water sample to monitor the change in temperature and its impact on the microwave response frequency/amplitude

Sample type	Volume fraction(%)	Temperature (°C)
Water sample	100	28
	100	30
	100	41
	100	49
	100	58
	100	68
	100	74
	100	83

3.6 Comsol simulation

COMSOL 5.1 simulation package was used to simulate for the resonant frequency inside the cylindrical cavity. Radio Frequency physic was used for the simulation. All the dimensions were drawn according to the experimental setup. The height of water level was calculated according to the percentages utilized in the experiment. The frequency was set between 5-5.7 GHz with 100 points to reduce the number of computational iterations.

The design of the measurement system must be feasible and applicable in the real world environment. The design has to be modified to maximize the accuracy of the result. Computational simulations will cut down the cost and time of fabricating different experimental cavity designs. The percentage of water is represented by using a circular section of the pipe.

3.6.1 Simulation using different level of water

The level of water was calculated using the Equation 3.1. Figure 3.7 shows the partially filled horizontal cylinder divided into sectors for calculations. The calculated level of water in different percentages is shown in table 1. The water level obtained is then used to define the different water level in the simulations. Figure 3.8 and 3.9 represent 60% of water in the pipe.

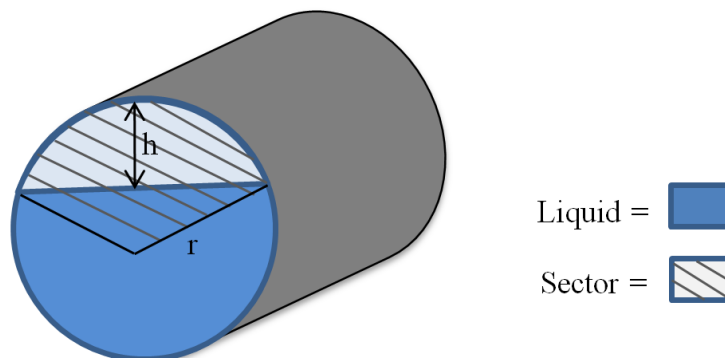

Figure 3.7. Partially filled horizontal cylinder

$$A_L = \pi r^2 - r^2 \cos^{-1} \left(\frac{r-h}{r} \right) + (r-h) \sqrt{r^2 - h^2} \quad (3.1)$$

Where A_L is the area of the liquid, r is the radius of pipe and h is the distance from the top of the pipe to the surface of the liquid.

Table 3.3. Height of water in different percentage of water.

Percentage of water (%)	Height (mm)
0	0
20	13.85
40	17.69
60	24.31
80	31.33
100	42.00

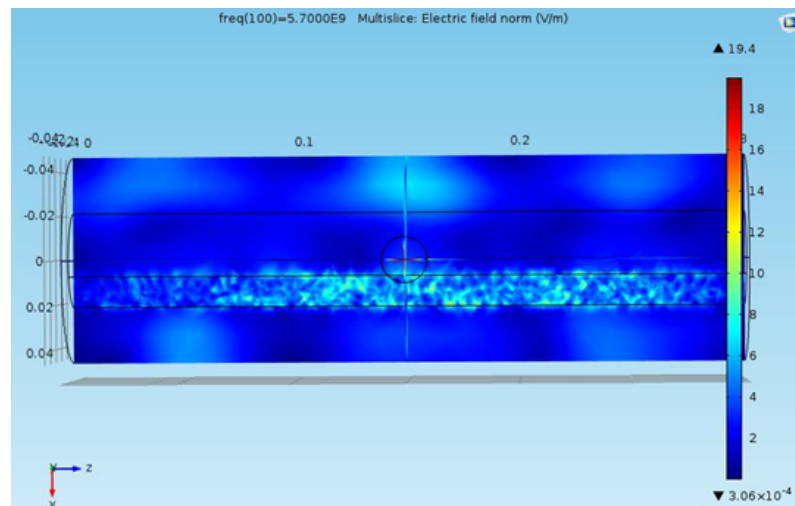

Figure 3.8. Schematic diagram of 60% of water in the pipe (front view).

It is important the simulation is carried out to verify the results due to the complexity and high order of resonant modes occurring inside the electromagnetic wave cavity sensor. By utilizing this technology, we will be able to understand what is happening inside the resonant cavity while the microwave resonate inside the cavity. Also, the result will help to verify the accuracy of the sensor compare to the experimental results.

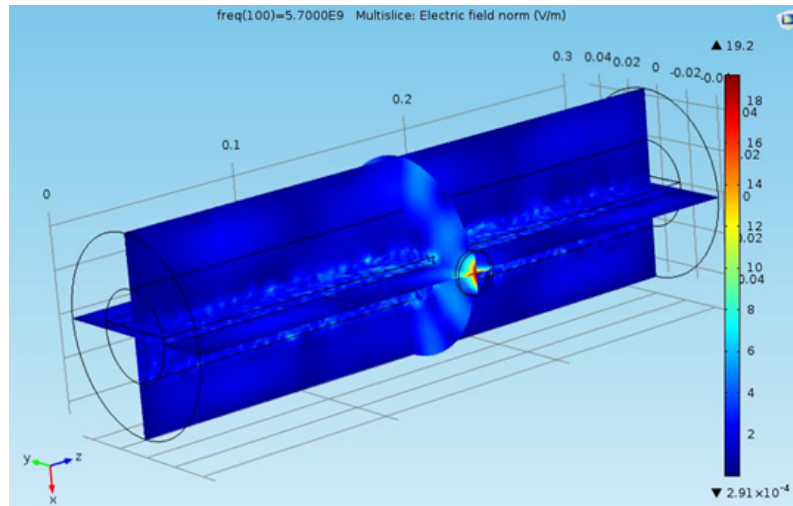

Figure 3.9. Schematic diagram of 60% of water in the pipe (3D view).

3.7 Two phase flow experimental and real time measurement

The sensor prototype set up is shown in Figures 3.10 and 3.11. An experimental test rig has been constructed and water is pumped through the pipe. The clear pipe before and after the cavity allows the water level to be measured using a transparent ruler, and the water volume fraction to be determined. The flow rate of the water is controlled using the controller built in the pump.

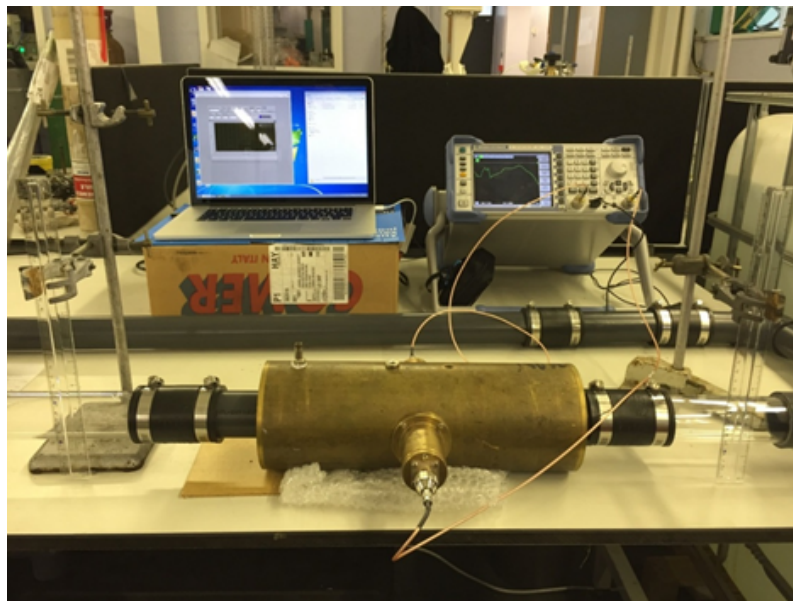

Figure 3.10. Two phase flow experimental setup

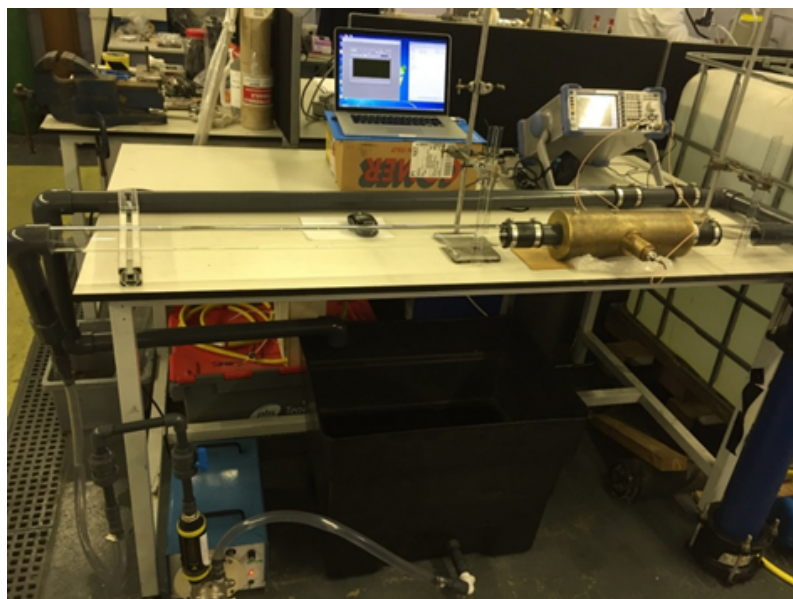

Figure 3.11. Two phase flow experiment setup (Full View)

This prototype uses the R&S Network Analyzer (ZVL 9 kHz -13.6 GHz), and it

consists of the Microwave Cavity System, Online Data processing computer (laptop computer), the loop antenna (transmitting and receiving antenna), and a PVC pipe. The frequency range is set from 5 GHz to 5.7 GHz with a 17kHz resolution (4000 points over 700 MHz of frequency). It captured the data during testing of the prototype sensor, when the percentage volume of water-gas mixtures was increased from 0-100% in the pipeline, in steps of 20%.

To visualize the flow before entering, and after coming out of the cavity sensor, acrylic pipe was connected to both ends of the PVC pipe. The diameter of the pipe was 50mm. The whole setup for the flow measurements consisted of the water tank, cavity sensor, PVC pipe, acrylic pipe, air pump, flow meter and a pump. The setup is shown in figure 3.12. The water flow rate and air flow rate is set to produce stratified, wavy, elongated and homogeneous flow. Then, the sensor is put in place to measure/detect the flow regime.

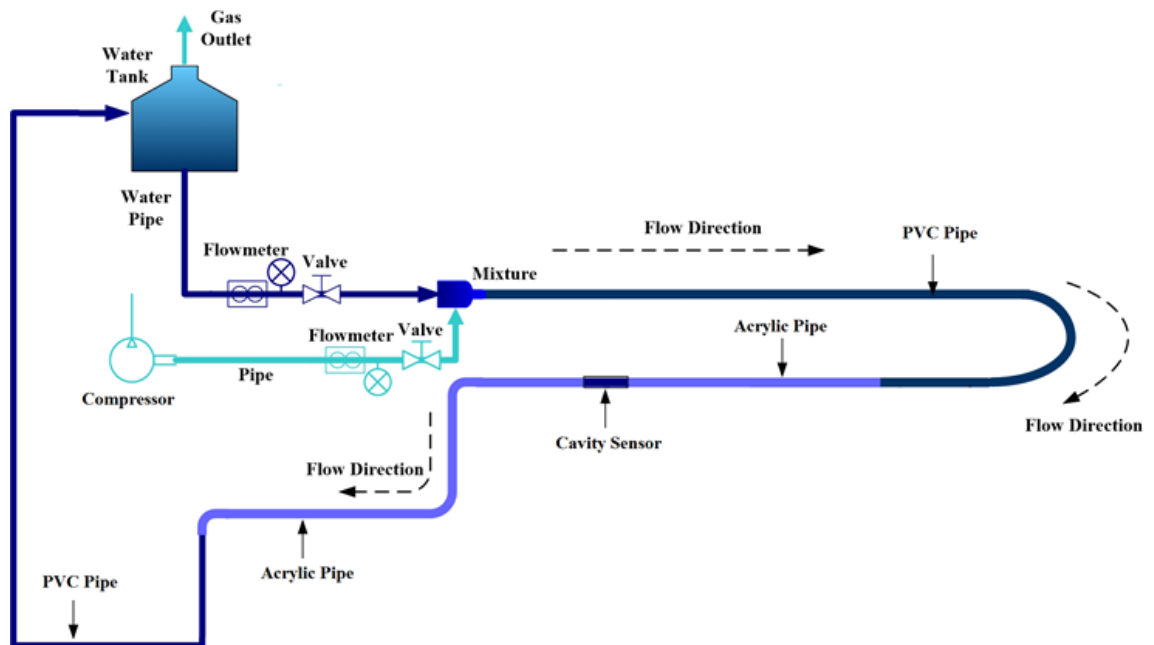

Figure 3.12. Schematic diagram of the two-phase flow experiment setup.

The flow experiment is carried out by first filling the water tank with 70% of water. The water pump is then switched on and the desired flow rate is adjusted by referring to

the flow meter. After that, the air compressor is turned on. The air valve opens slowly to introduce air to the system. The air flow rate is adjusted to the desired flow rate and is selected by referring to the air flow meter. When the water air mixture is returned to the tank, the air escapes to the environment and the water is recirculated back to the system.

3.8 Rectangular sensor cavity system

As we know any change in the material's concentration, percentage, type, etc. will change its permittivity that causes the change in the microwave response when the material interacts with it. By measuring this response over the range of discrete frequencies the material can be characterised. Water, for example, has relatively high permittivity. Hence, a small change in water fraction may result in comparatively large frequency shift. This can be detected using a cylindrical cavity operating at 5-5.7 GHz frequency. On the other hand, a non-polar material such as oil or gas also has low permittivity. This tiny change in the permittivity is hardly detected by the cylindrical cavity sensor. To address this problem, a newly designed rectangular cavity sensor is added to the system to pick up the tiny shifts in the permittivity as shown in Figure 3.13. It is a complement to the cylindrical cavity's function.

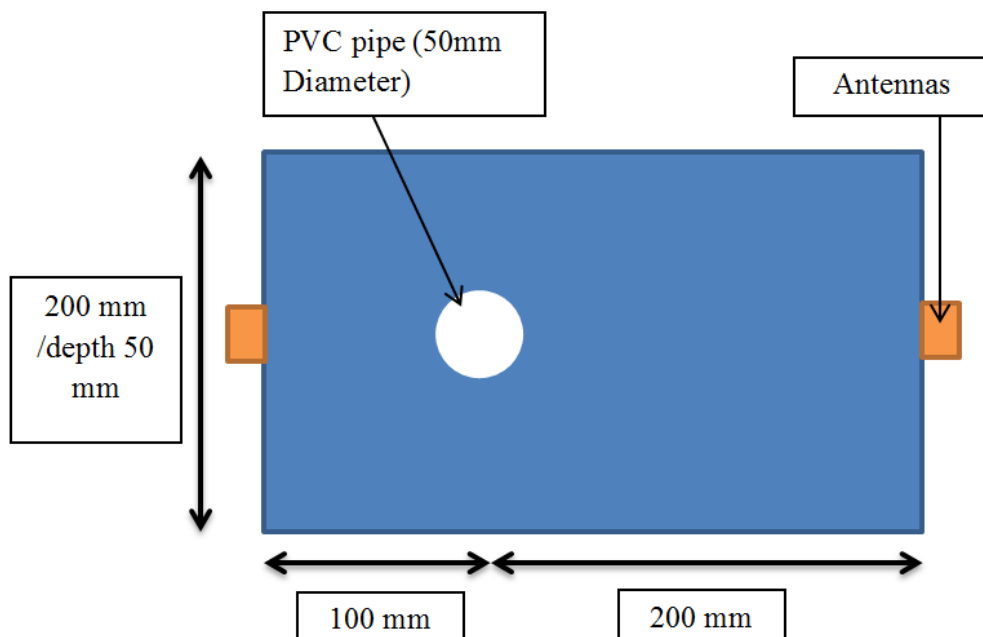

Figure 3.13. Rectangular sensor cavity design.

The experimental detection of oil-gas was tested using a 50mm diameter PVC pipe in a rectangular cavity sensor, and conducted using 20% fraction increment of oil from

0% to 100% of oil. For better understanding of the different fraction of oil-air, the samples analyzed for the percentage of the volume fraction between oil and air is shown in Table 3.4. The experiment for the monitoring and analysis of the volume fractions was repeated three times and the average value was calculated.

Table 3.4. List of two phase system of oil-air tested for the monitoring and analysis of the volume fractions

Sample type	Volume fraction (%)		Temperature (°C)
	Oil Fraction	Air fraction	
Oil-air (two phase)	0	100	20
	20	80	20
	40	60	20
	60	40	20
	80	20	20
	100	0	20

An interesting phenomenon was observed during the experiment of oil-air liquid fraction. The little changes in the permeability can be detected using the rectangular cavity. An experiment was carried out to detect the temperature changes using 100% water fully filled pipe. The pipe was filled using 100°C water and the heat in the water was dissipated to the environment via conduction and convection while the data was taken. The data was recorded for every drop of 5°C. For better understanding of the different temperature of water-air analysis, the samples analyzed for the temperature of the fully filled pipe with water are shown in Table 3.5. A temperature probe was inserted inside the pipe away from the cavity to measure the water temperature. The experiment was repeated three times and the average temperature was calculated.

Error is a measure of the reliability and the accuracy of the data obtained in an experiment. It is vital to be able to calculate and estimate the experimental error. For this research work, the margin of error for this experiment should be less than 5-10% as mentioned in the literature review.

Table 3.5. List of temperature of fully filled pipe for the temperature detection

Sample type	Volume fraction (%)		Temperature (°C)
	Water Fraction	Air fraction	
Water-air	100	0	40
	100	0	45
	100	0	50
	100	0	55
	100	0	60
	100	0	65
	100	0	70
	100	0	75
	100	0	80
	100	0	85

3.9 Summary

The present invention relates to a multiphase flow metering system, a microwave transmitting and receiving antenna and an associated method for measuring the relative fluid fraction and temperature of fluid mixture passing through a pipe. The present research work utilizes a non-intrusive microwave sensor detection method to determine the fluid fraction and temperature of two phase flow inside a pipe.

The permittivity (or dielectric constant) in the fluid mixture passing through the pipe causes shifts in the frequencies and amplitude, which can be measured using a receiving loop antenna to detect the changes in the permittivity. The changes in the permittivity can be the different phases or the changes between the volume fractions of the fluid mixture.

In this research, the electromagnetic sensor cylindrical cavity system is used to analyze various fractions of water-air mixture. The results were compared to check for consistency for both the case of static and dynamic flow. The statistical analysis of the captured data is observed and modelled using mathematical interpretation to relate the relationship between the amplitude data with the changes in the water-air fractions. Then, a temperature independent study is carried out to check for the effect of temperature measuring fluid. The system will also be tested for stratified, wavy, elongated bubbles and homogeneous flow regimes detection.

While the cylindrical cavity sensor is used to be detect the water level independent to the temperature change. The electromagnetic rectangular cavity sensor system is developed to pick up the tiny shifts in the permittivity when the low permittivity material is used or temperature changes. The microwave sensor system is also tested for water-air fraction, water-oil fraction, oil-air fraction and water temperature detection.

CHAPTER 4: RESULTS AND DISCUSSION

4.1 Introduction

This chapter details results and discussion obtained from experiments and simulations. The response of the frequency to the changes of fluid fraction is identified and shown in this section. To validate the results of the cylindrical cavity sensor, Comsol simulation is carried out to verify the results. A temperature independent study is also conducted to study the effect of fluid temperature to the sensors. Then, an experiment test rig is set up to study the detection of different flow regimes. It is concluded that the system is able to identify different flow regimes. The problem of detecting low permittivity arises when the detection of oil and gas fraction is carried out. A novel solution of incorporating a rectangular cavity to the system is used to pick up the tiny shift of the frequency. Selected cases will be chosen for comparison between static and stratified flow for validation purposes.

4.2 Microwave spectrum analysis of the results

Figure 4.1 shows the comparison of water-air fractions as in Table 3.1 and discussed in the previous section. The highlighted area in the figure demonstrate a shift in the frequency and change in the amplitude (peak of the curve) of samples when the ratio of the volume fraction of air decreases from 100-0% and water increase from 0-100%. Analysis of Figure 4.1 shows that:

- The frequency of the microwave response curve decreases and shifts to the left from 5.496 GHz to 5.470 GHz as the increase in the water fraction takes place in five steps of 20% each. It equates to a total shift of approximately 25.5 MHz. Keeping into consideration the sensitivity of the technique, the shift is significant.
- In addition to the frequency shift, a significant change in the amplitude was also

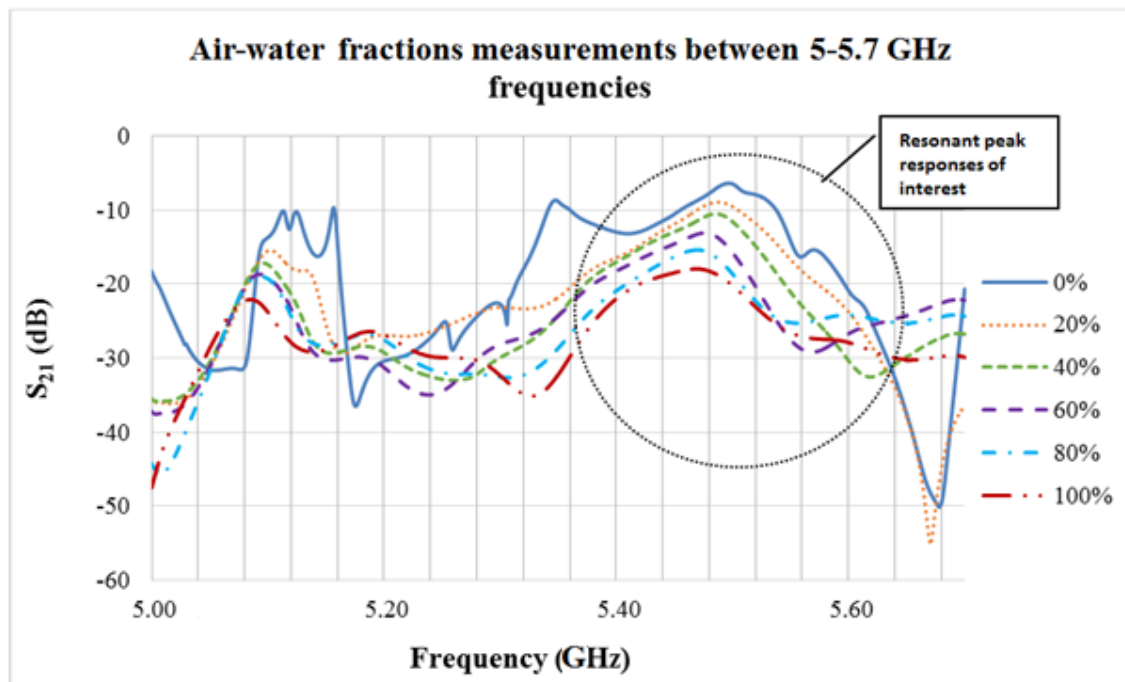

Figure 4.1. S_{21} (dB) measurements of the frequency response of water-air fractions using microwaves at 5-5.7 GHz

observed as in Figure 4.1. The amplitude decreases as the percentage of the water increase and air decreases. The overall decrease in the amplitude from 100% air to 100% water is approximately -11.2789 dB.

- Collectively it is demonstrated that both the shift in the frequency and change in the amplitude can be used to distinguish the increase/decrease in the volume fractions of water and gas in two phase flows.
- The results of the frequency shift and amplitude follow a specific pattern throughout the measurements showing the consistency of the microwave measurement technique.

A second set of measurements was carried out to monitor the change in the volume fraction of water-oil. The fractions of two phase fluid of water-oil analyzed are shown in Table 1. The similar sample design was used whereby the measurements started with 100% of oil and 0% of water in the pipe. The ratio was then changed in 20% step changes with decreases in the oil and increases in the water up to the point where the whole pipe

was filled with 100% of water with no oil left. The result of the measurements is shown in Figure 4.2. The highlighted area of Figure 4.2 demonstrates the same pattern as in Figure 4.1 whereby:

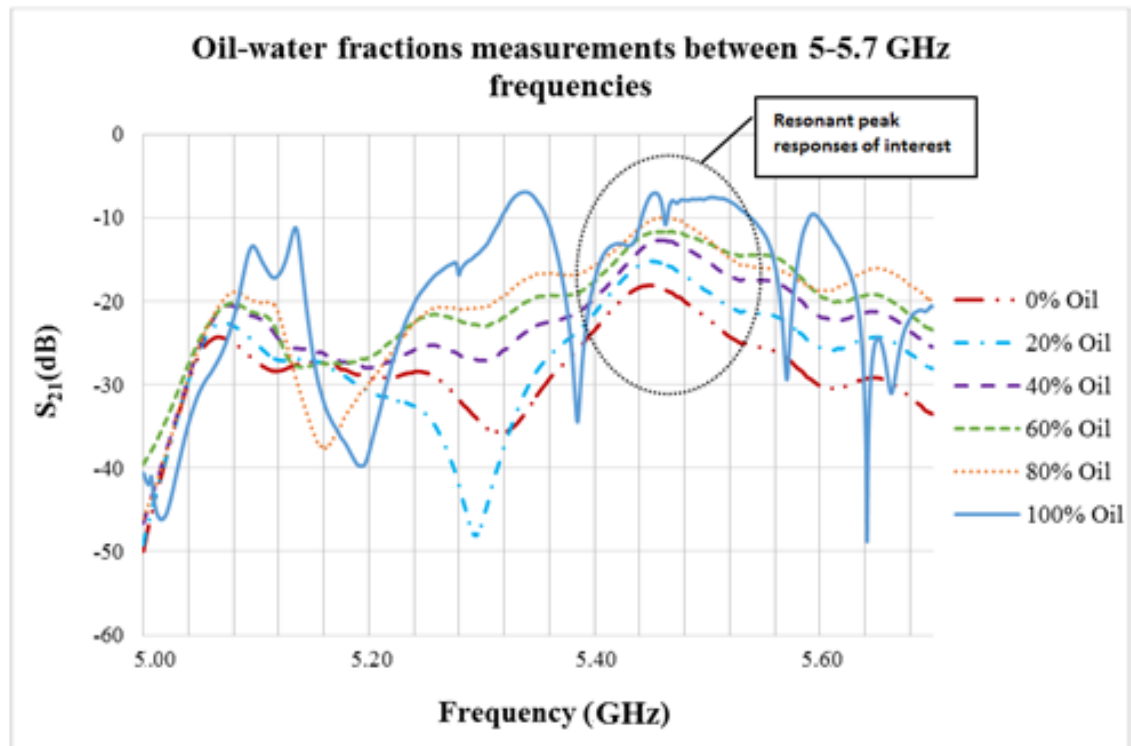

Figure 4.2. S_{21} (dB) measurements of the frequency response of water-oil fractions using microwaves at 5-5.7 GHz

- A continuous shift in the frequency to the left (decrease) is observed when the percentage of water is increased and oil is decreased. The shift observed is from 5.504 GHz for 100% oil to 5.449 GHz for 100% water. This totals to a significant 54.6 MHz shift.
- As in Figure 4.1, the amplitude also changes from high to low with increases in the percentage of water fraction. The total decrease in the amplitude was recorded to be -10.562 dB.
- Both the amplitude change and frequency shift could be used to analyze and monitor the fraction percentage of the oil-air two phase systems. The results are very

consistent in terms of changes in both the frequency and amplitude. The measurements were also repeated 5 times to check the accuracy and repeat-ability of the results.

It was also important to analyze the changes between each of the 20% fraction change of both water-air and water-oil flows. The frequency shift and amplitude change profile was plotted for each of the water-air and water-oil fractions and is shown in Figure 4.2. The results of the frequency plot in Figure 4.3 show that there is a measureable frequency shift for each of the fraction percent changes. The frequency decreases when the water fraction increases to 100% in both water-air and water-oil two phase flows.

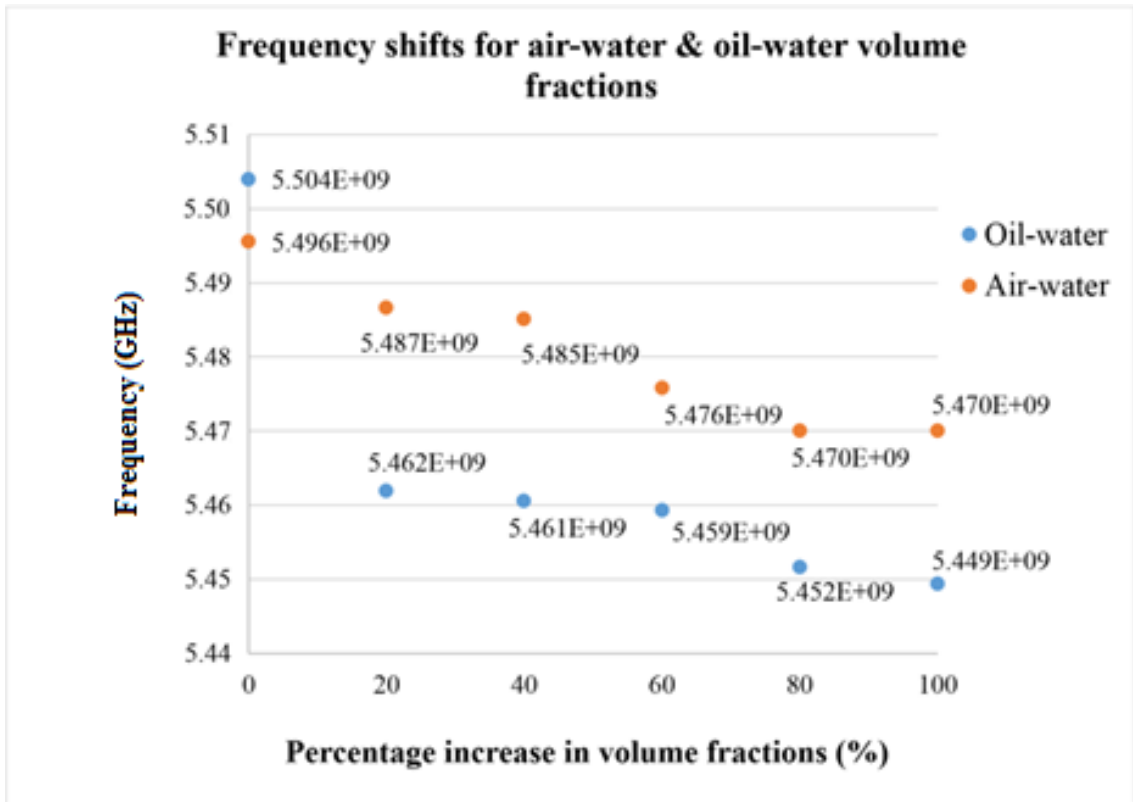

Figure 4.3. Graph of the frequency shift for each of the water-air and water-oil volume fractions change

A common phenomenon was a shift to the right with a decrease in the water percentage in the fractions. This showed a decrease in the dielectric properties of the mix. There was a prominent change in the amplitude in the case of both the water-air and water-oil fractions. From the results, reduction in the amplitude can be linked to the increase in the

water fraction percentage in proportion to both the air and oil. Since, water is “lossy” in nature, the experimental results obtained supported this theoretical fact.

Figure 4.4 shows the COMSOL simulation 3D view of the electric field inside the cylindrical cavity for 0% of water (filled with air) for illustration purposes.

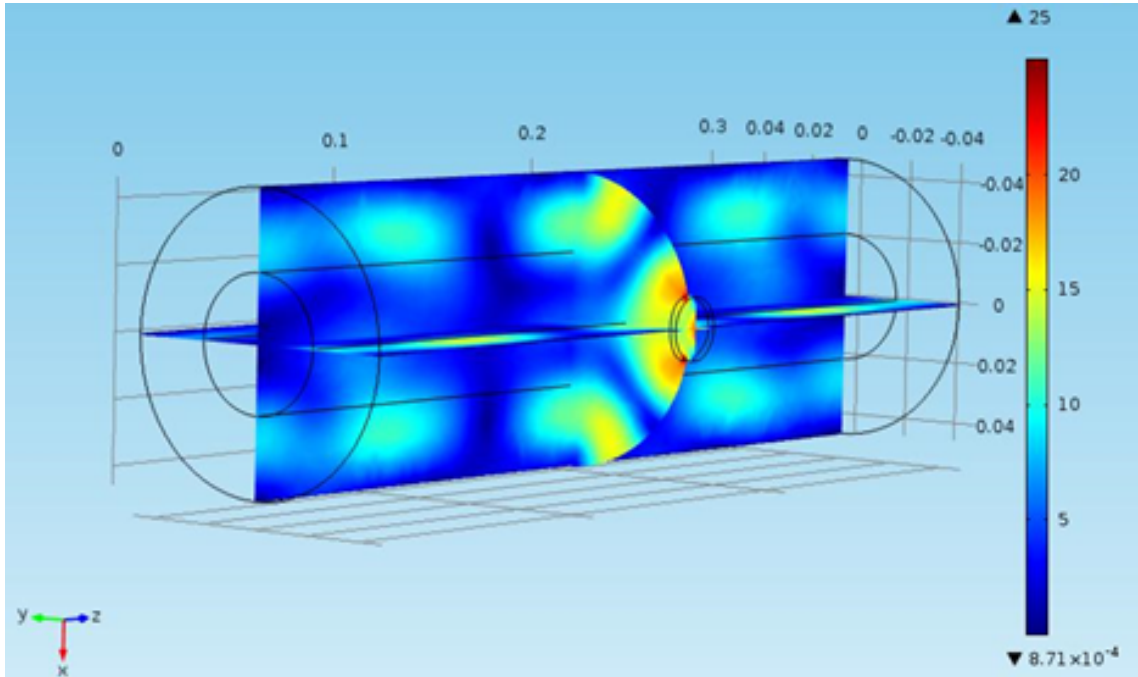

Figure 4.4. Electrical field intensity inside the cylindrical cavity.

Figure 4.5 shows the comparison between the experimental and simulation results. Only water-air fraction was simulated in this research to illustrate the accuracy of experimental analysis in comparison to the simulated results. The resonant frequency of each percentage of water from the experimental results was obtained and compared with the simulated results. Both the results show a drop in frequency when the percentage of water increases. The average error between the experiment and simulation result is 13MHz. It can be observed that the noticeable errors were 0% and 100% of water inside the pipe, the error were 34MHz and 17MHz respectively. It is due to tiny amount of water present or the pipe was not completely dry for 0% of water. For the 100% water, it is cause by tiny air bubbles trapped inside the pipe when it is fully filled. Overall, both of the experiment and simulation results shows similar trend.

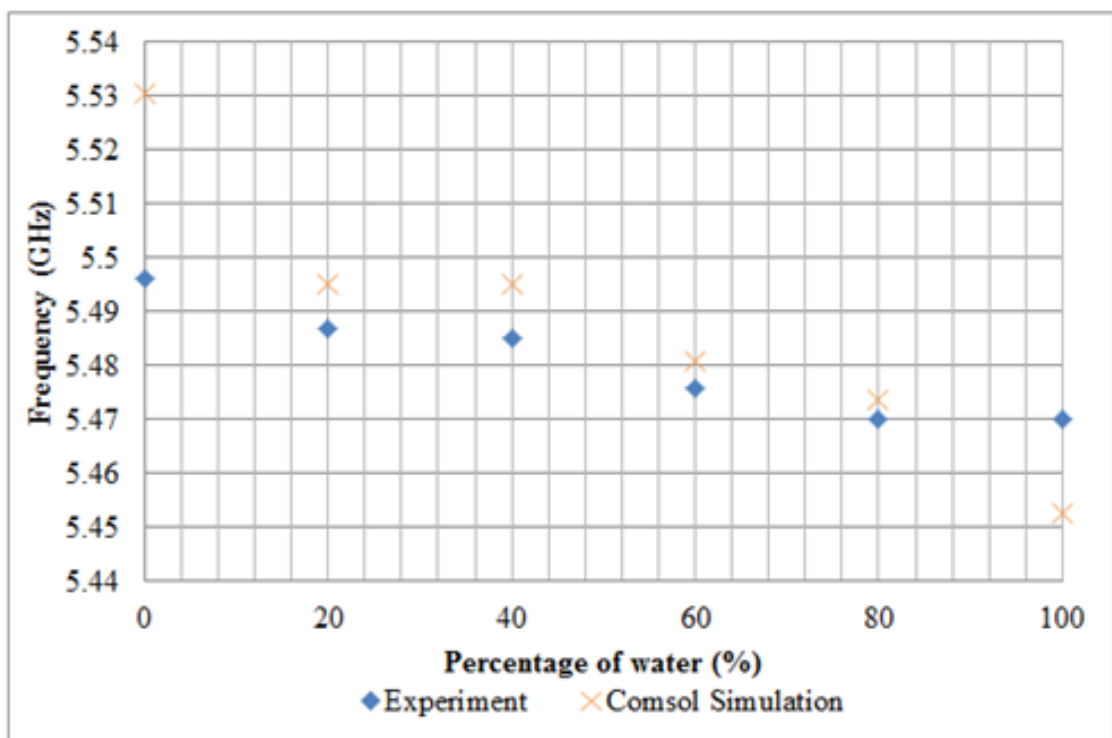

Figure 4.5. Comparison of resonant frequency between experimental and simulation results

4.3 Statistical analysis of repeatability and amplitude change

To address the repeatability, experimental measurements of both the water-air and water-oil fractions were repeated five times at different times. The data was then used to calculate the average amplitude and standard deviation as shown in Figure 4.6. The major errors are observed at 0% of water for water-oil and 100% of water for water-air. These errors may be due to the air bubbles that may be trapped inside the oil or water when fully filled.

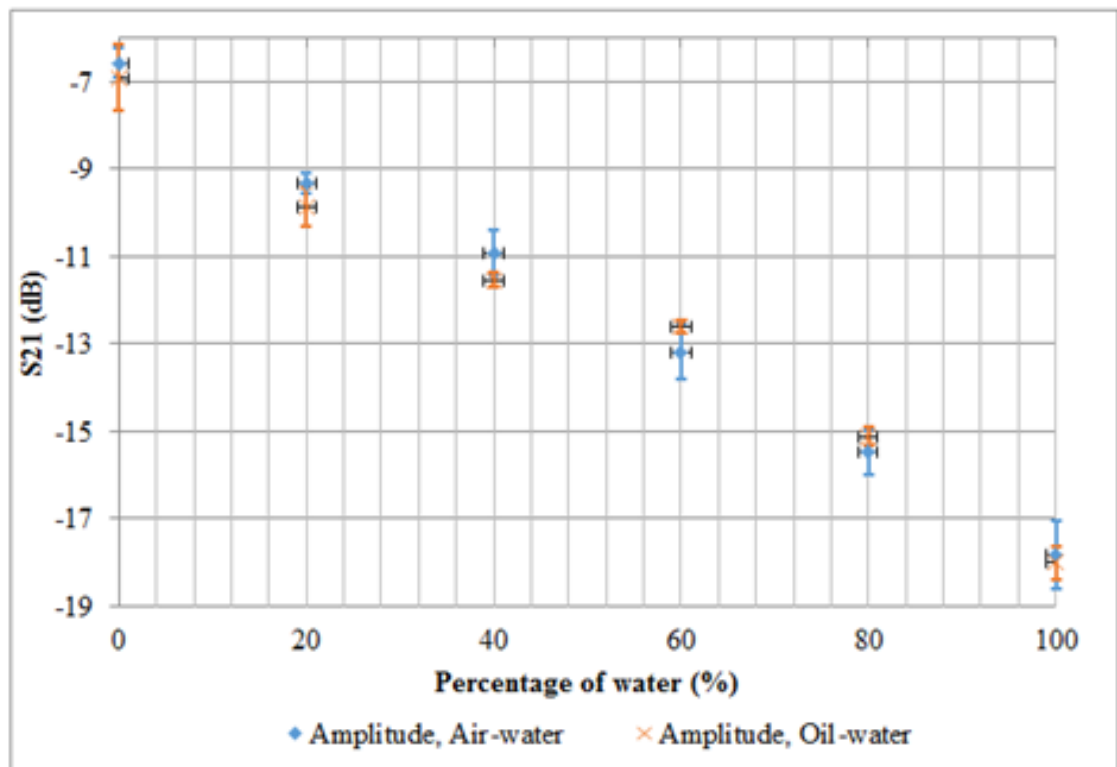

Figure 4.6. Average amplitude for each percentage of water with standard deviation error bars.

It can also be observed that a slightly higher error was noticed at 0% and 100% water fraction in the mix. This could be attributed to the instrumentation and measurement error. However, most of the response of microwaves to the material (mix) was consistent. The accuracy presented in the measurement technique shows that it can be further developed for industrial scale analysis.

The output from the microwave responses in section 4.2 shows that the amplitudes

obtained can be modeled accurately using a linear equation and could be presented as a function of change in the water fraction percentage. Figure 4.7 shows the linear relationship of the amplitude change to the fraction change of water in two phase system. It can be observed that the microwave signal amplitude decreases proportionally with the increase in the percentage of water. The plotted data shows a linear relationship between the volume fraction of water and amplitude of microwave signal captured.

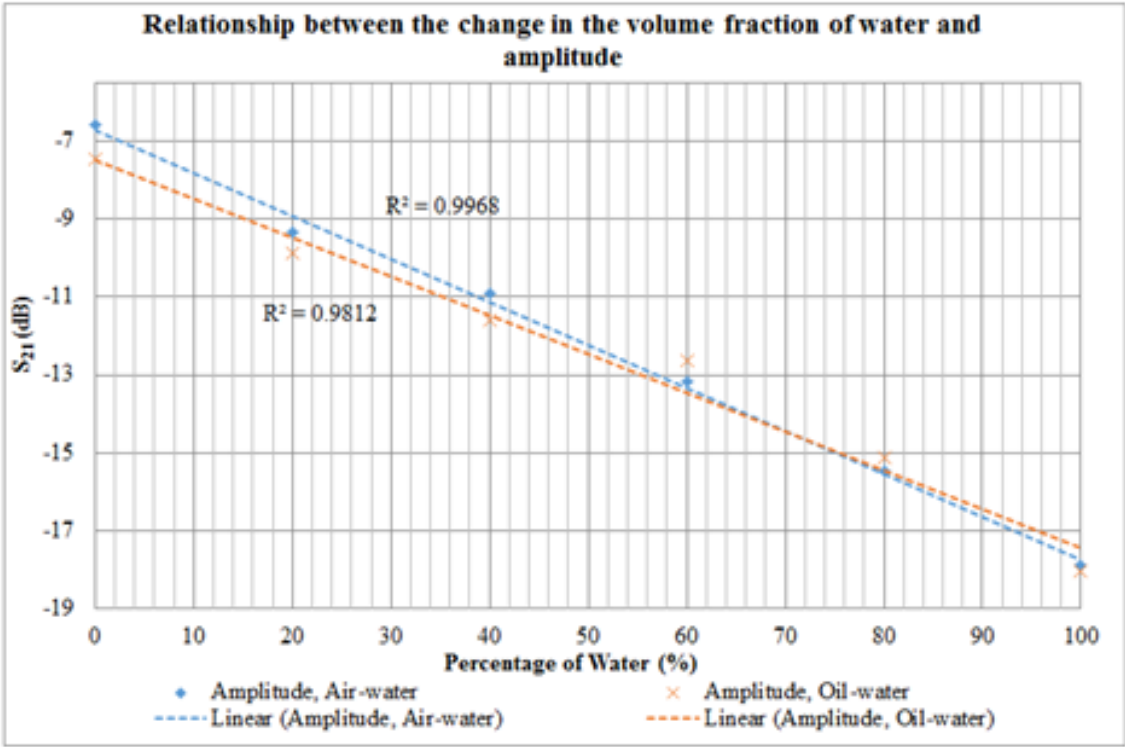

Figure 4.7. Relationship between the change in the volume fraction of water and amplitude in two phase systems

A linear fit of the response of the microwave interaction with the water-air and water-oil fractions showed that each of the 20% change in the water fractions can be modelled accurately and predicted if required. This could be helpful in the further development of the sensor system and intelligent analysis software tool to predict and detect in real-time various types of two phase water-air and water-oil fractions.

4.4 Static Experiment

Figure 4.8 shows the S_{21} spectra in the range 5GHz to 5.7GHz as the percentage volume of water in the pipeline increased from 0-100%. This frequency, specifically around 5.5GHz, was identified as suitable for further investigation due to its steady change with water fraction and its insensitivity to temperature. The total frequency shift for this peak, between 0% water to 100% water in the pipeline, is 300 MHz. It can be observed that the maximum amplitude for each of the percentages drops steadily from 0% to 100% and shifts to the left. The resonant frequencies in this range means that the maximum amplitude can be accurately modelled using a linear equation which is a function of the water fraction.

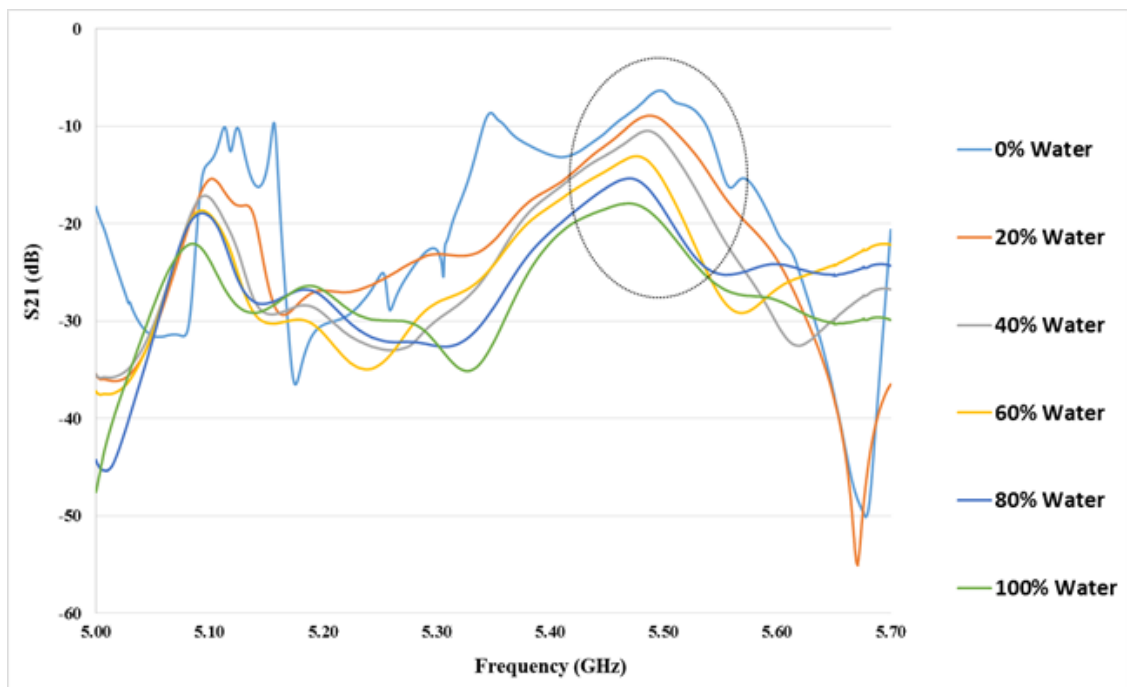

Figure 4.8. Graph of S_{21} (dB) versus frequency for different percentage of water.

Figure 4.9, shows how the detected microwave amplitude decreases proportionally with the increase in the percentage of water. The maximum error calculated from the equation to the data acquired is less than 5%.

Figure 4.10 shows the system front panel using Labview software. This research software application was designed to enable the system to display and save the data in

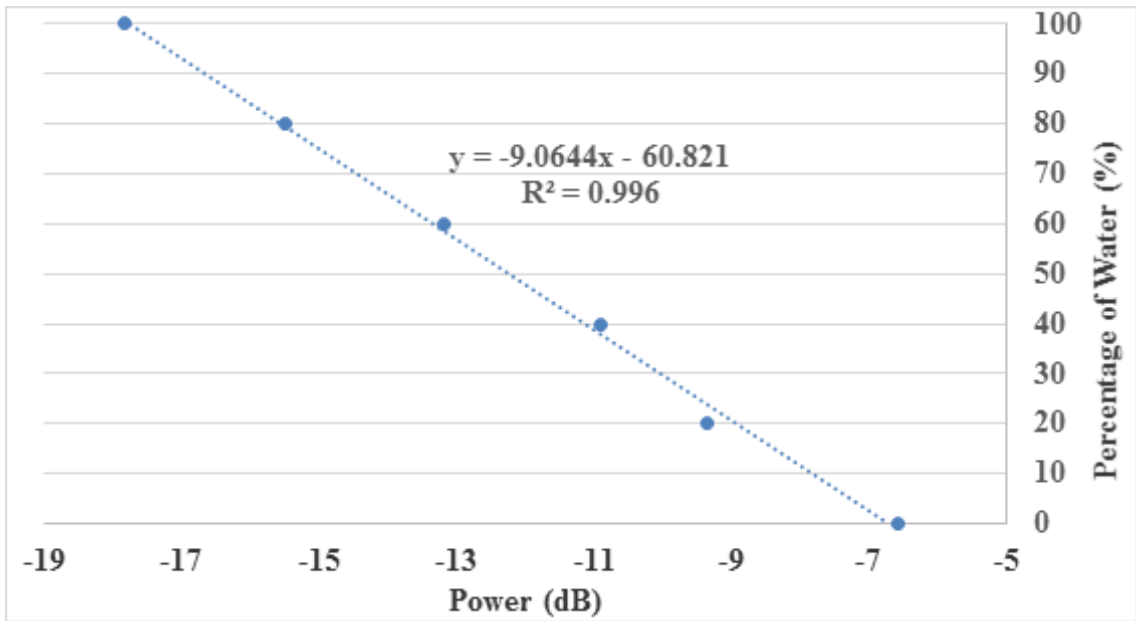

Figure 4.9. Graph of Percentage of water versus S_{21} (dB)

real time. The system was connected and tested in real time.

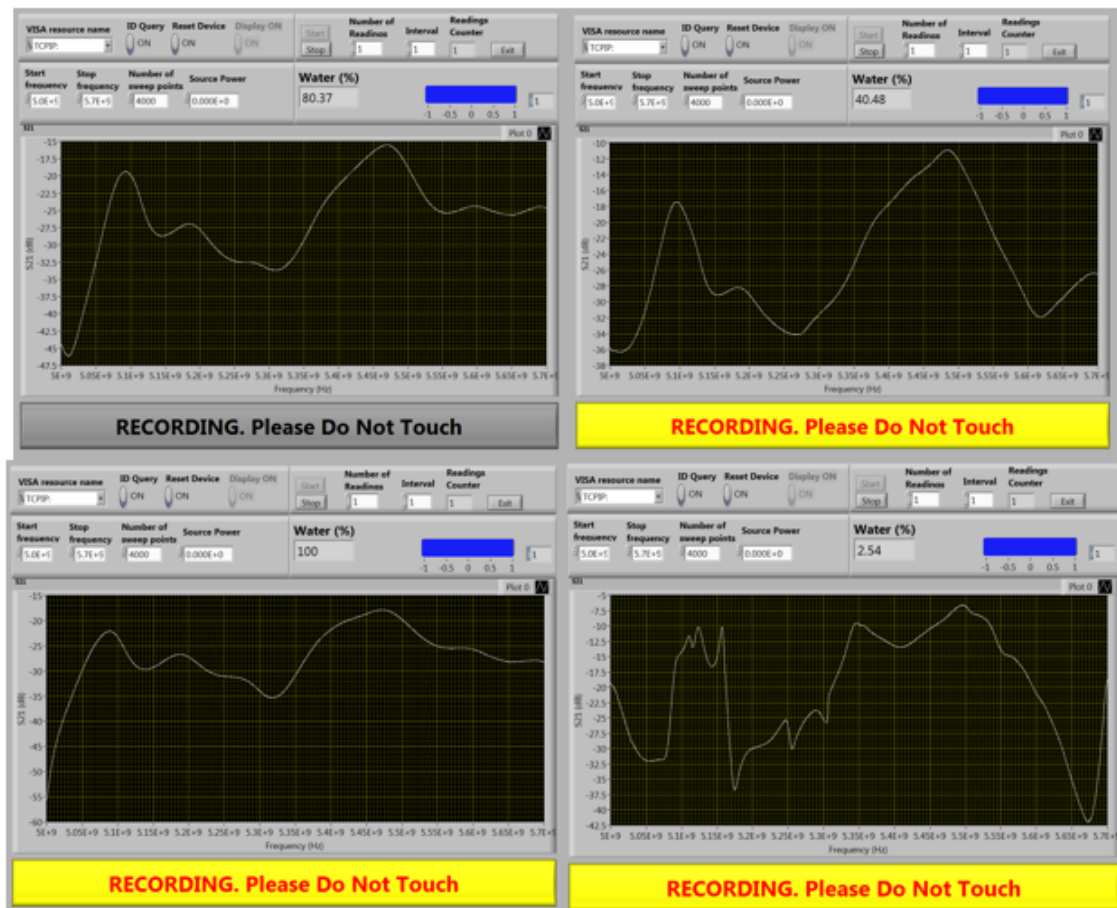

Figure 4.10. Online front panel reading for different percentage of water.

4.5 Temperature effect study

Another analysis was on a water filled pipe to monitor if the change in temperature affects the microwave response curves. This was to monitor the temperature dependence of the microwave measurement technique. The results of the captured data corresponding to the temperature of water were listed in Table 4.1.

Table 4.1. Analysis of the water sample to monitor the change in temperature and its impact on the microwave response frequency/amplitude

Sample type	Volume fraction(%)	Temperature (°C)
Water sample	100	28
	100	30
	100	41
	100	49
	100	58
	100	68
	100	74
	100	83

Figure 4.11 shows the frequency and amplitude of 100% water in the pipe with different temperatures. It shows that no frequency shift is observed down to the temperature of 28°C. The temperature of the water was varied between 83°C and 28°C and this has negligible effect on the accuracy of the system, despite the permittivity of water changing with the temperature. The reason behind the phenomenon is the different overlapping modes negating the affect.

Furthermore, the results were promising with no shift in the resonant peak observed with temperature decrease. This potentially shows the independence of the microwave measurement technique despite the changing permittivity of water when heated. It is important in terms of the industrial applications because the measurements could be carried out in real-time without the two phase mix dependence on the important factors such as temperature. This however needs to be verified for smaller changes in the temperature through a temperature controlled data recording tool. The temperature dependence also need to be verified for the three phase systems and more complex percentages of mix.

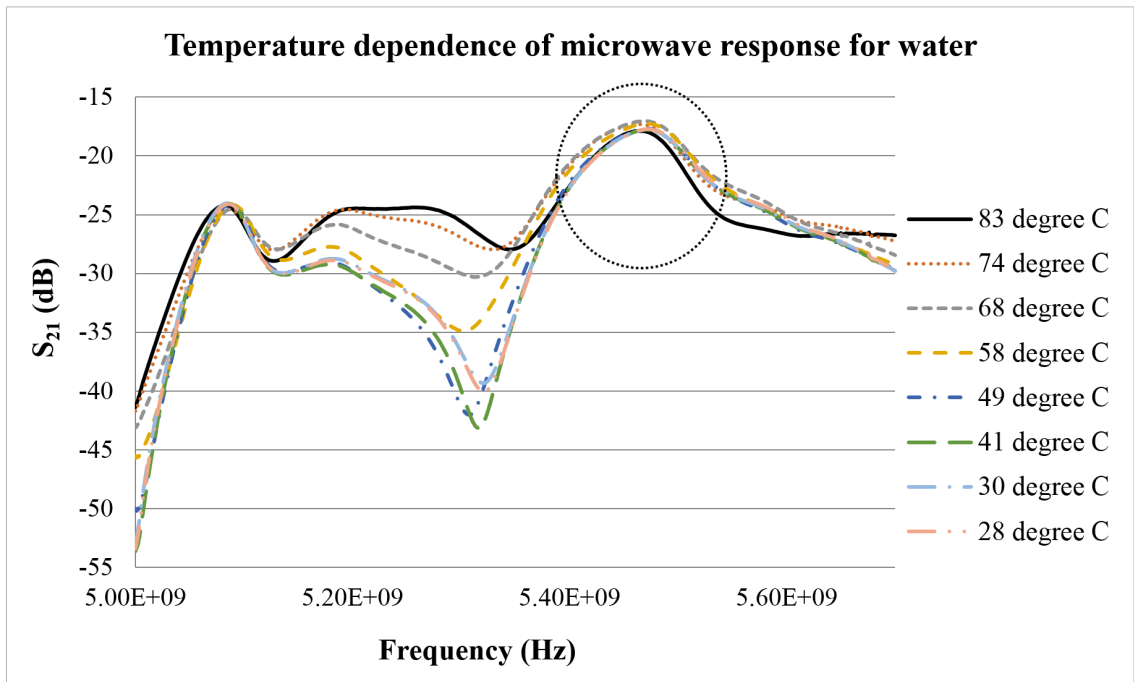

Figure 4.11. Graph of S_{21} (dB) versus the frequency at different temperatures for 100% water.

The results shows the system is able to detect the water level independence of the temperature change between 83°C and 28°C and it has negligible effect on the accuracy of the system.

4.6 Two Phase flow Experiment

Figures 4.12 and 4.13 represent experiments for 20% and 80% of water respectively. The system captures the data and display it using Labview software. The system was automated, using National Instrumentation (NI) devices by monitoring the maximum amplitude shift. Due to the flowing water, it is difficult to measure the percentage or volume of water in the pipe precisely. Parallax error may also contribute to the measurement. The error in the flowing water was slightly higher than 5% in this experiment.

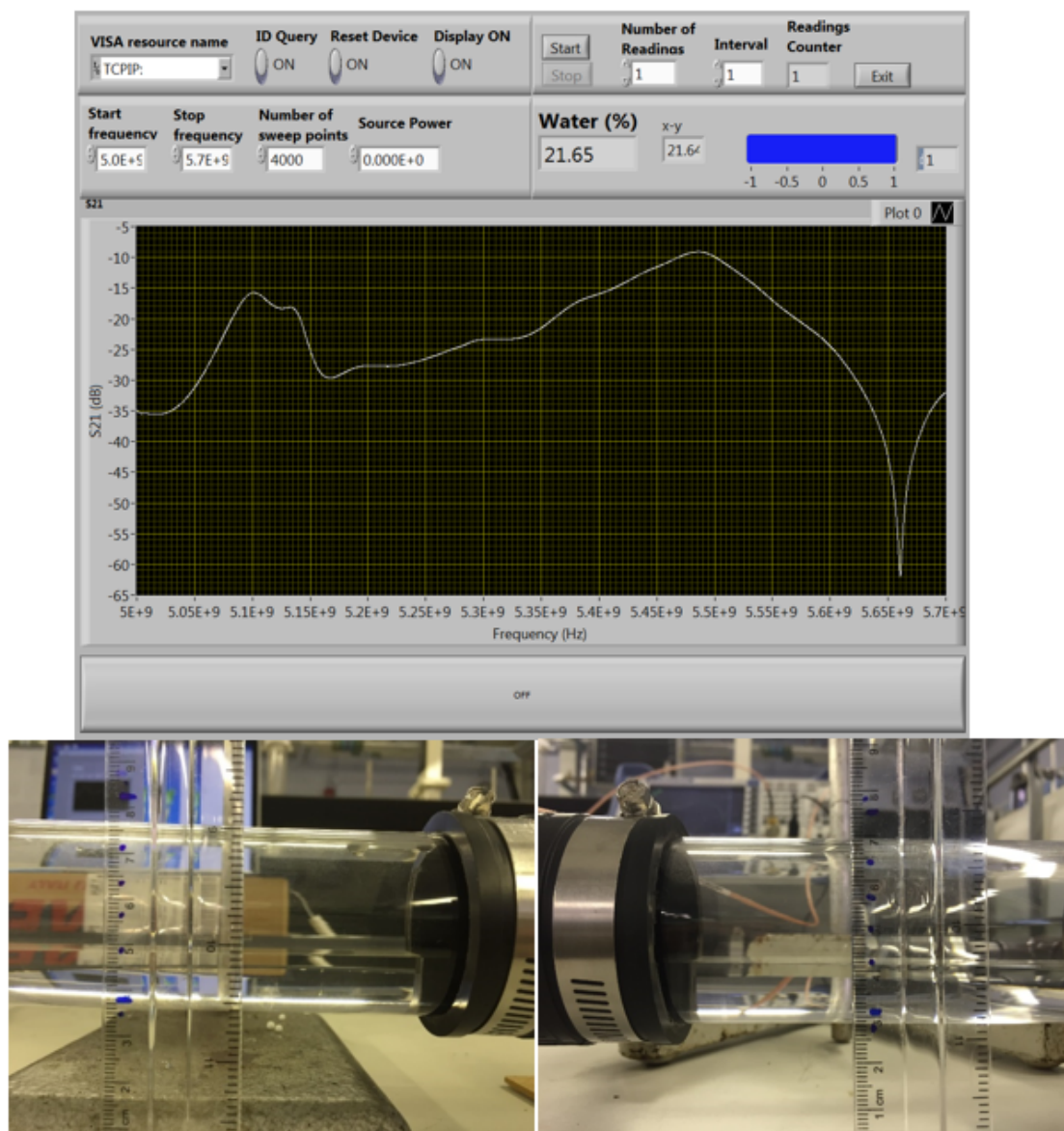

Figure 4.12. Experimental of 20% of water flowing in the pipe.

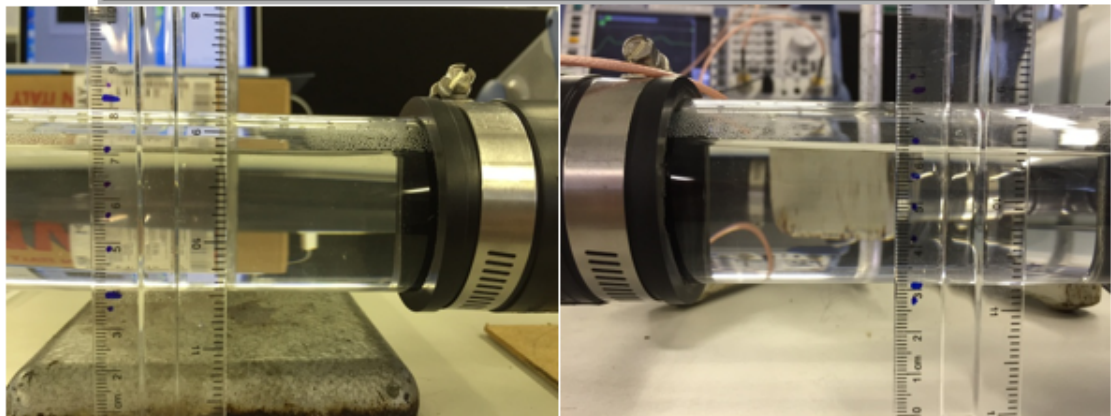
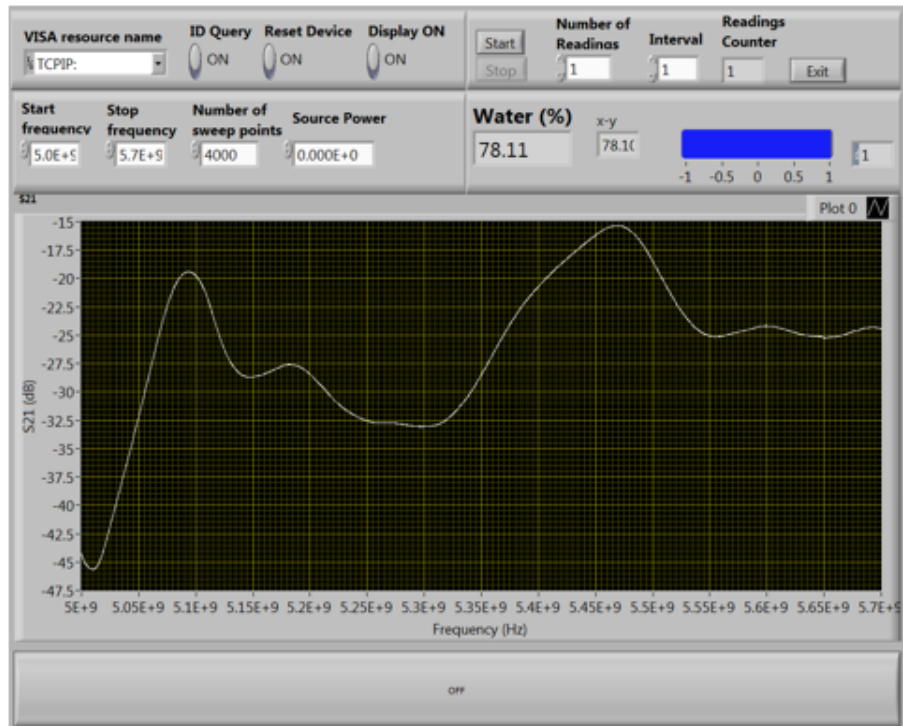

Figure 4.13. Experimental of 80% of water flowing in the pipe.

Figure 4.14 shows how the mode peaks changed as the percentage volume of water in the pipeline increased from 0-100%. The peak decreased by about 2.2 dB as the percentage of water increased by 20%. These phenomena can be represented using a linear equation.

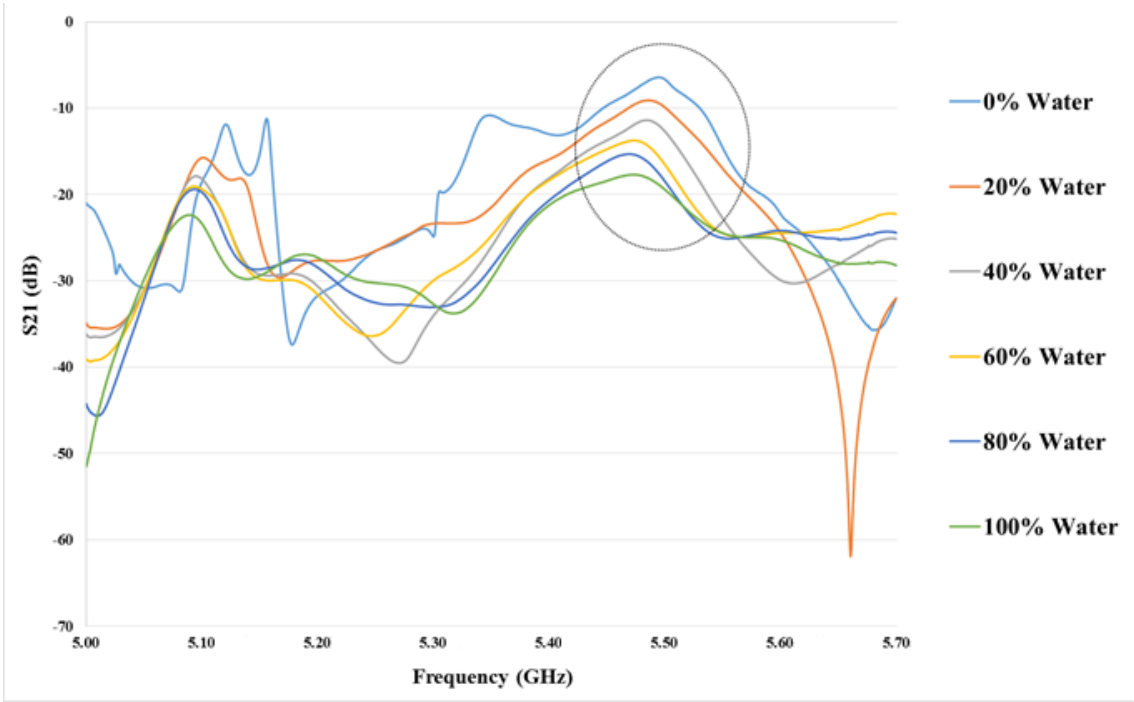

Figure 4.14. Graph of S₂₁ (dB) versus frequency for different percentage of flowing water.

Figure 4.15 shows the peak value of each percentage of static and flowing water in the pipe. The movement of water does not affect the spectrum. Both static and flowing water produce almost the same result. It can be concluded that, the electromagnetic wave cavity sensor used in the experiment in this research has successfully detected the water fraction (stratified flow) inside the pipe in real time.

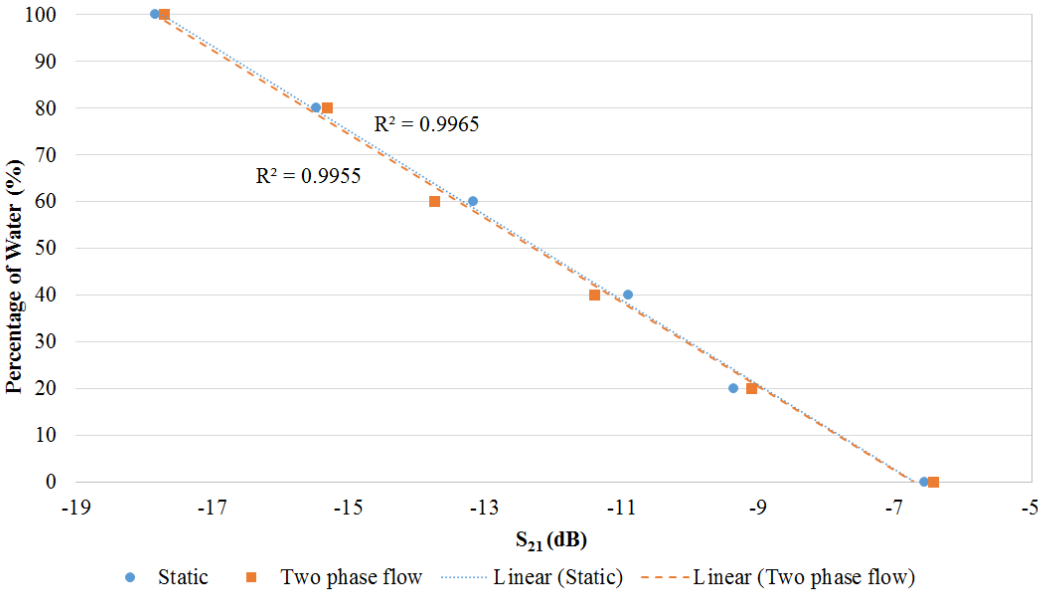

Figure 4.15. Graph of Percentage of water versus power (dB).

The results show the system is able to detect both static and dynamic flow of two phase flow. The movement of water does not affect the sensor detection and analysis of the result. It can be concluded that, the electromagnetic wave cavity sensor used in the experiment in this research has successfully detected in real time the two phase stratified flow inside the pipe.

4.7 Wavy and elongated bubbles flow measurement and detection

Figure 4.16 shows the snapshot of the wavy flow during the experiment. The flow rate of water was set to 8 L/min whereas the air input was set at 1.4 Nm³/hr. The continuous wave was observed as a result traveling along the pipe. Figure 4.17 shows the maximum and minimum level of water flowing inside the pipe over time. The amplitude oscillation is observed to be approximately 50-55% indicating the wavy flow.



Figure 4.16. Snapshot of the wavy flow.

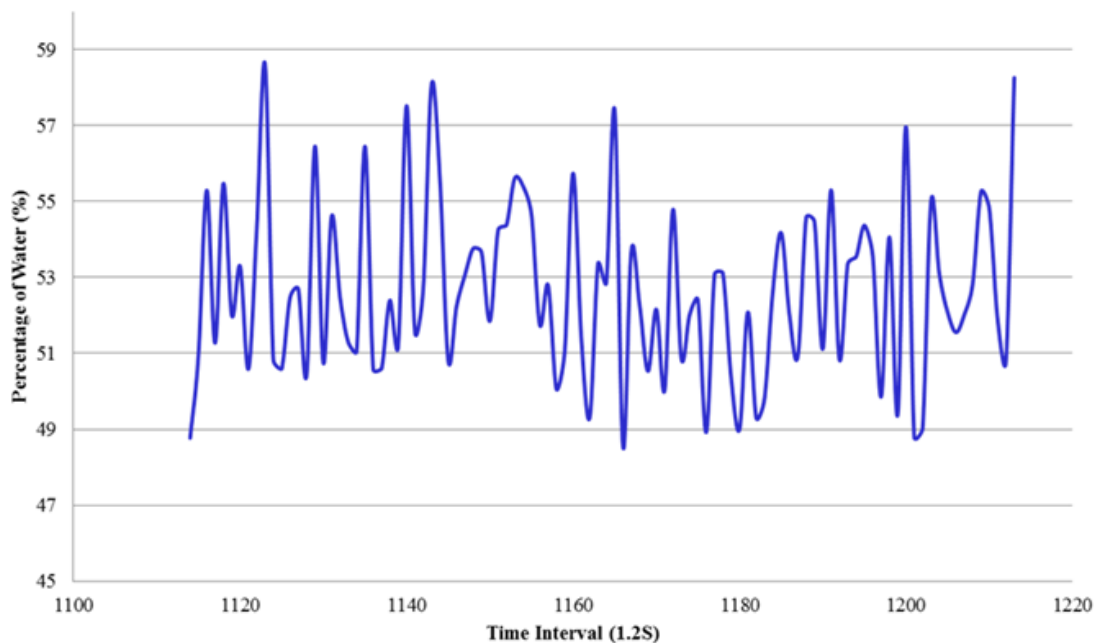

Figure 4.17. Graph of the percentage of water versus time for the wavy flow.

Similarly, figure 4.18 shows the snapshot of the elongated bubbles flow produced during the experiment. The water flow rate was set to 18 L/min and the amount of air was fixed at 1.5 Nm³/hr. As a result, continuous elongated bubbles flow was observed traveling along the pipe. Figure 4.19 shows the maximum and minimum level of water flowing through the pipe over the period of measurements. The amplitude oscillation was significantly different in comparison to the wavy flow and was recorded approximately between 50-100% indicating the elongated bubbles flow.



Figure 4.18. Snapshot of the elongated bubbles flow.

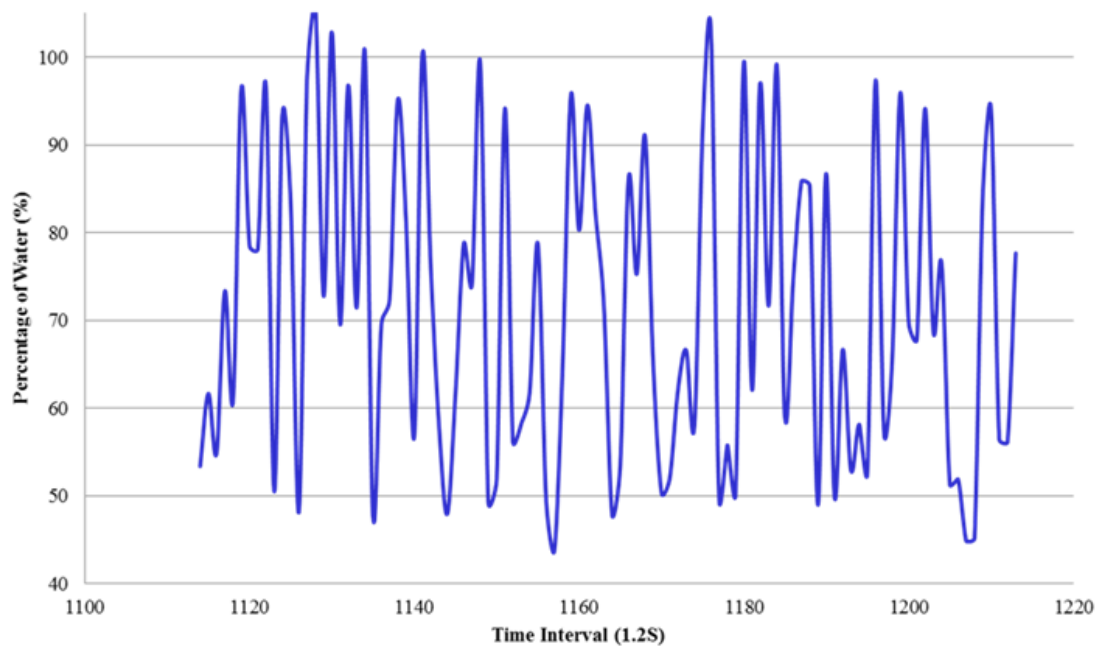

Figure 4.19. Graph of the percentage of water versus time for the elongated bubbles flow.

Overall, the combination of stratified, wavy and elongated bubbles flow results were shown in figure 4.20. By analyzing the result of each flow characteristic, the data can be used to identify what type of flow in real time. This method is quick and simple to be utilized for laboratory and industry application. In order to process the data, software like Labview, Matlab, C programming and etc. can be programmed to capture, process and display the data in real time.

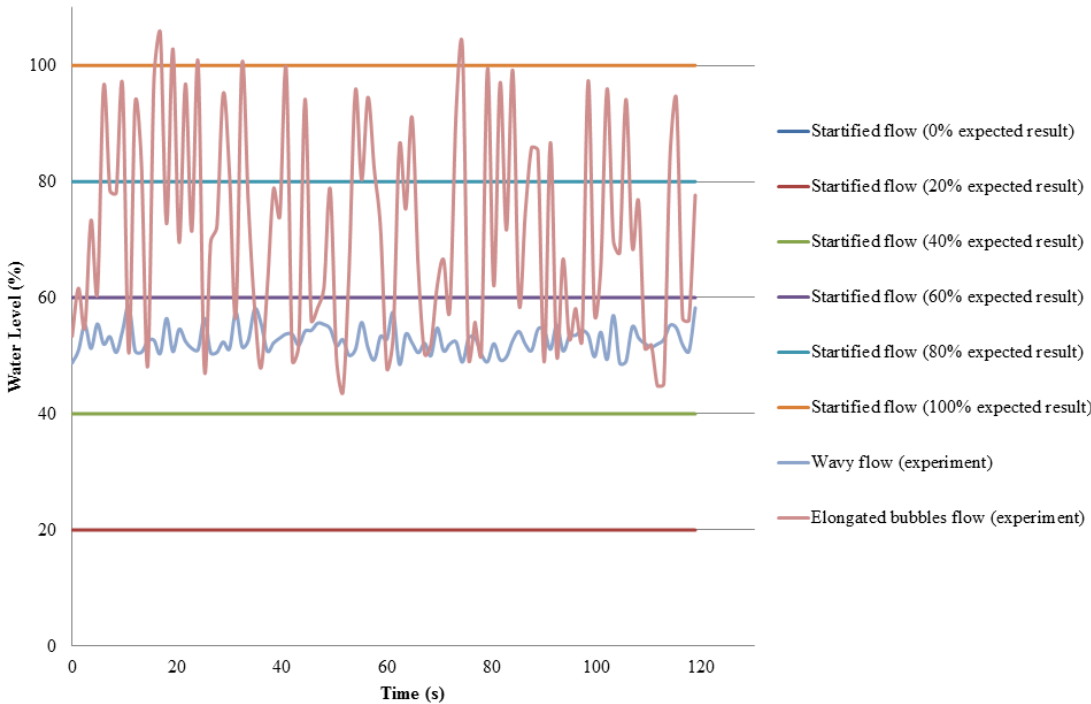

Figure 4.20. Combination of stratified, wavy and elongated flow result.

This study demonstrate the effectiveness of microwave sensing techniques in the analysis of many types of flows including wavy and elongated bubbles flow. The results show substantial evidence to demonstrate the suitability of using microwave sensors in the analysis of wavy and elongated bubbles flow with different air input.

4.8 Homogeneous flow measurement and detection

In order to create a homogeneous flow, the test section was changed to vertical setup. Figure 4.21 shows the homogeneous flow regime before entering the cavity sensor. The water flow rate was set to 56 L/min and air input was varied between 0, approximate 0.2 Nm³/hr, 1 Nm³/hr and 2 Nm³/hr. The water and air flow meter were used in the experiment. The difference in the air input affects the number and size of bubbles flowing inside the pipe. Tiny bubbles can be observed at low air flow rate and vice versa. Figure 4.22 show the results of the microwave response to varying homogeneous flow types inside the pipe with changing air input. The measurements of S_{21} parameters (transmission co-efficient) were taken between 5-5.7 GHz frequency range. It can be observed that the microwave response peaks of the minimum points (highlighted in figure 4.22) shift to the right when the air input increases. There is also a reduction in the amplitude with the increase in the air input. The curves obtained can be processed further using sophisticated analysis techniques such as neural network to determine air or water fraction in a two phase system (Kntor & Plik, 2016; OConnor et al., 2012). In such a case, the shift in the frequency as well as the minimum point obtained (amplitude value) can be potentially used to estimate the rate of air input.

This study demonstrate the effectiveness of microwave sensing techniques in the analysis of many types of flows including homogeneous flow. The results show substantial evidence to demonstrate the suitability of using microwave sensors in the analysis of Homogeneous flow with different air input.

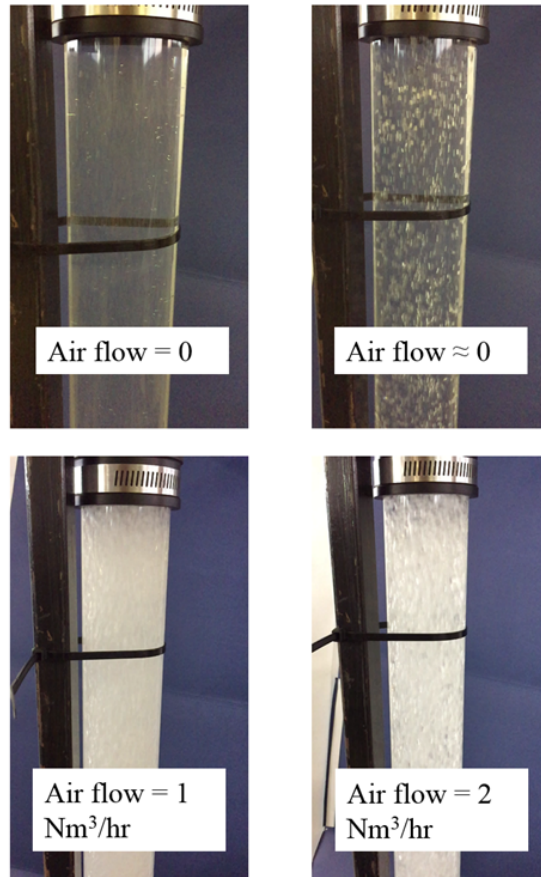

Figure 4.21. Snapshot of the Homogeneous flow produced with different air input.

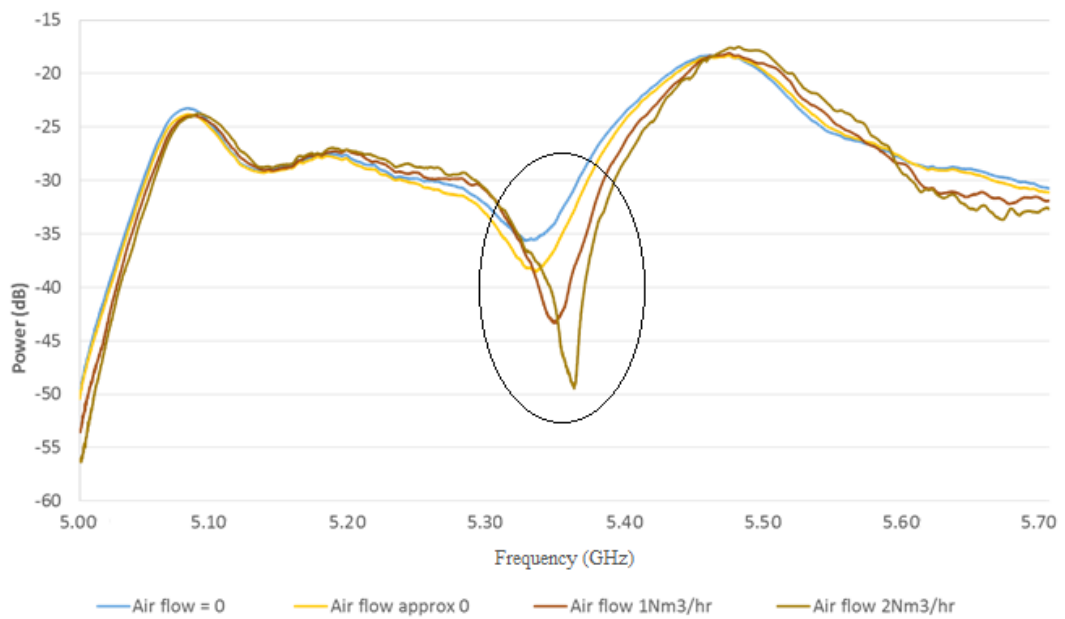

Figure 4.22. Graph of determination of the homogeneous flow type with varying air input using microwave response parameter S_{21} .

4.9 Dual Cavity sensor system

An experiment is conducted to monitor the change in the volume fraction of oil-air using rectangular cavity. The fractions of two phase fluid of oil-air analyzed are shown in Table 4.2.

Table 4.2. List of two phase system of oil-air tested for the monitoring and analysis of the volume fractions

Sample type	Volume fraction (%)		Temperature (°C)
	Oil Fraction	Air fraction	
Oil-air (two phase)	0	100	20
	20	80	20
	40	60	20
	60	40	20
	80	20	20
	100	0	20

The similar sample design was used whereby the measurements started with 0% of oil and 100% of air in the pipe. The ratio was then changed in 20% step changes with increases in the oil and decreases in the air up to the point where the whole pipe was filled with 100% of oil with no air left. The result of the measurements is shown in figure 4.23 and the observations are as follows:

- The third resonant frequency mode is chosen as the reference due to the obvious frequency shift and its consistency.
- A continuous shift in the frequency to the left (decrease) is observed when the percentage of oil is increased and air is decreased. The shift observed is from 1.042 GHz for 100% oil to 1.027 GHz for 100% air. This totals to a 15 MHz shift.
- Collectively it is demonstrated that both the shift in the frequency and change in the amplitude can be used to distinguish the increase/decrease in the volume fractions of water and gas in two phase flows.

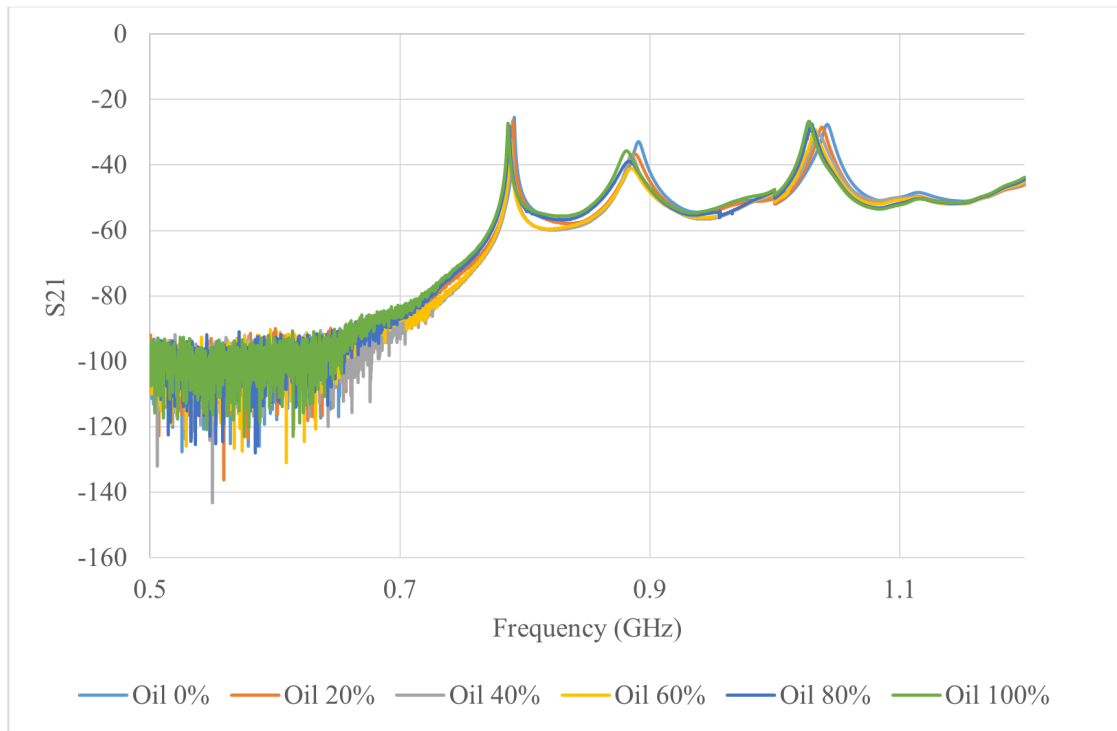

Figure 4.23. Graph of S_{21} versus frequency for different percentage of oil.

- The frequency shift could be used to analyze and monitor the fraction percentage of the oil-air two phase systems. The repeat-ability of the frequency is plotted in Figure 4.24. The results were highly repeatable and very consistent in terms of changes in the frequency.
- The frequency decreases consistently when the oil fraction increases from 0% to 100% in this case, it can be represented using a linear function.

Following the experiment of the low permittivity detection method. Another experiment is conducted to investigate the temperature detection of water temperature using a rectangular cavity. The results of the measurements is shown in Figure 4.25 and the observations are as follows:

- The fourth resonant frequency mode is chosen as the reference due to the obvious frequency shift and its consistency.
- A continuous shift in the frequency to the left (decrease) is observed when the

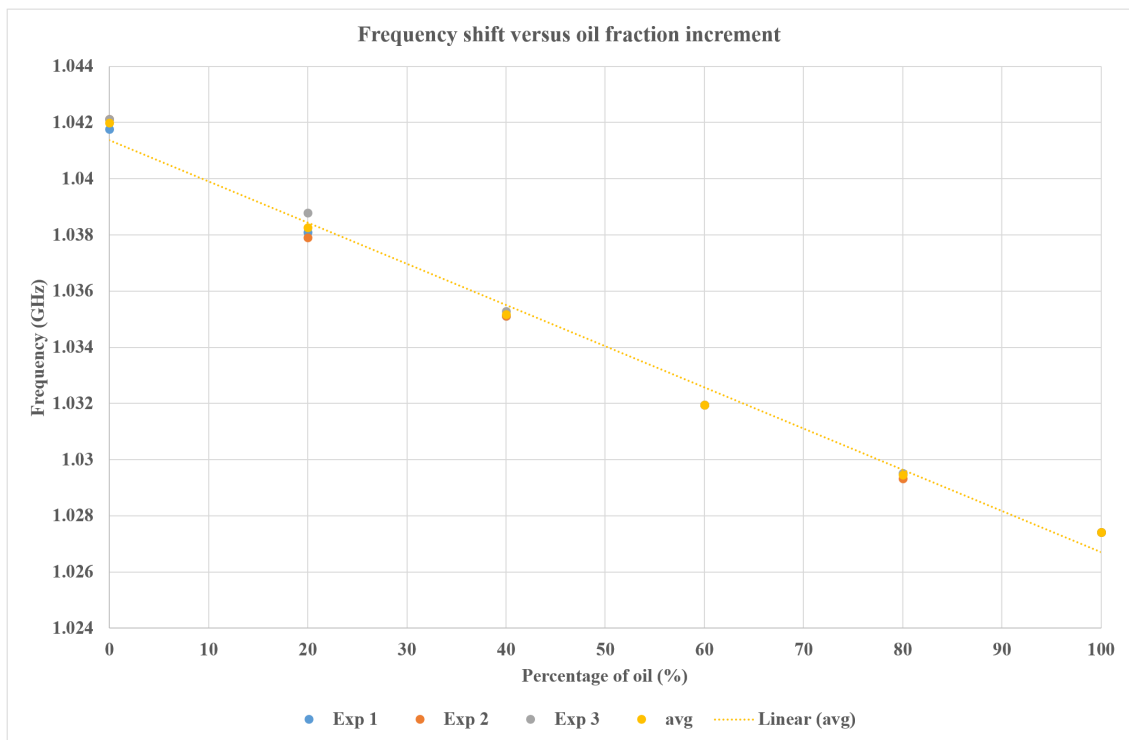

Figure 4.24. Graph of frequency shift versus oil fraction increment.

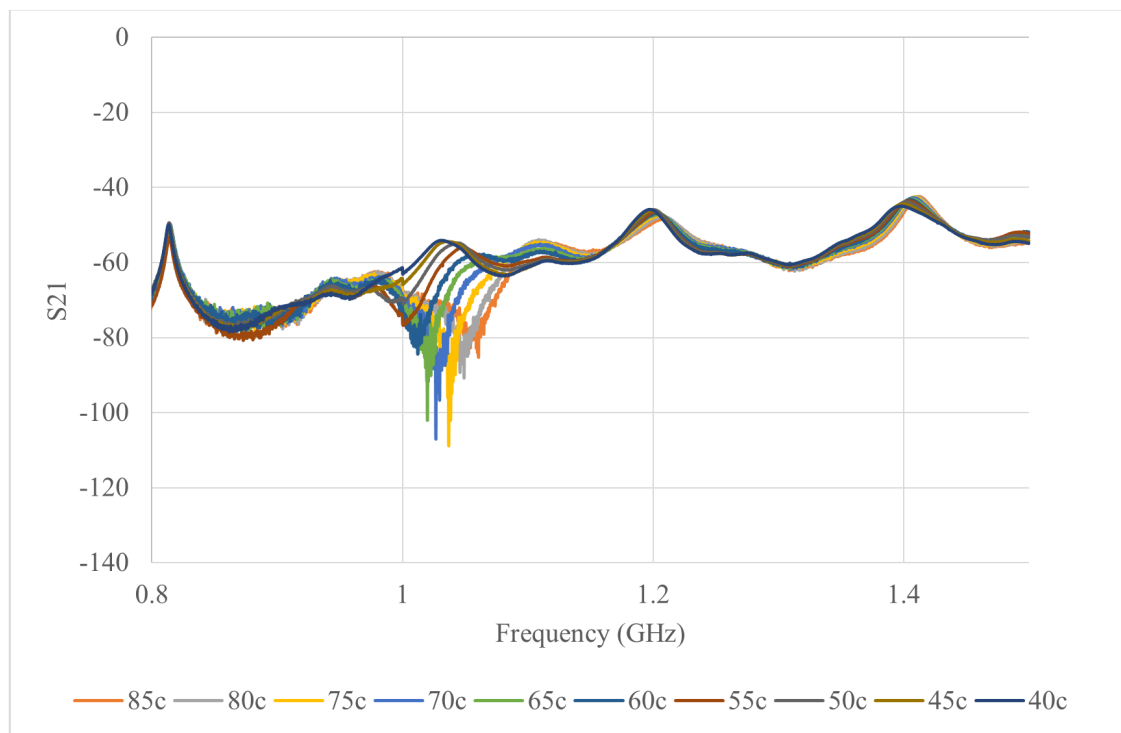

Figure 4.25. Graph of S_{21} versus frequency for different temperature.

temperature is decreased. The shift observed is from 1.209 GHz for 85°C to 1.197 GHz for 40°C. This totals to a 12 MHz shift.

- The frequency shift could be used to detect and monitor the temperature of the

water in the systems. The repeat-ability of the frequency is plotted in Figure 4.26. The results were fairly repeatable and consistent as shown in table 4.3. The average standard deviation of the data is 0.965 MHz which is relatively low.

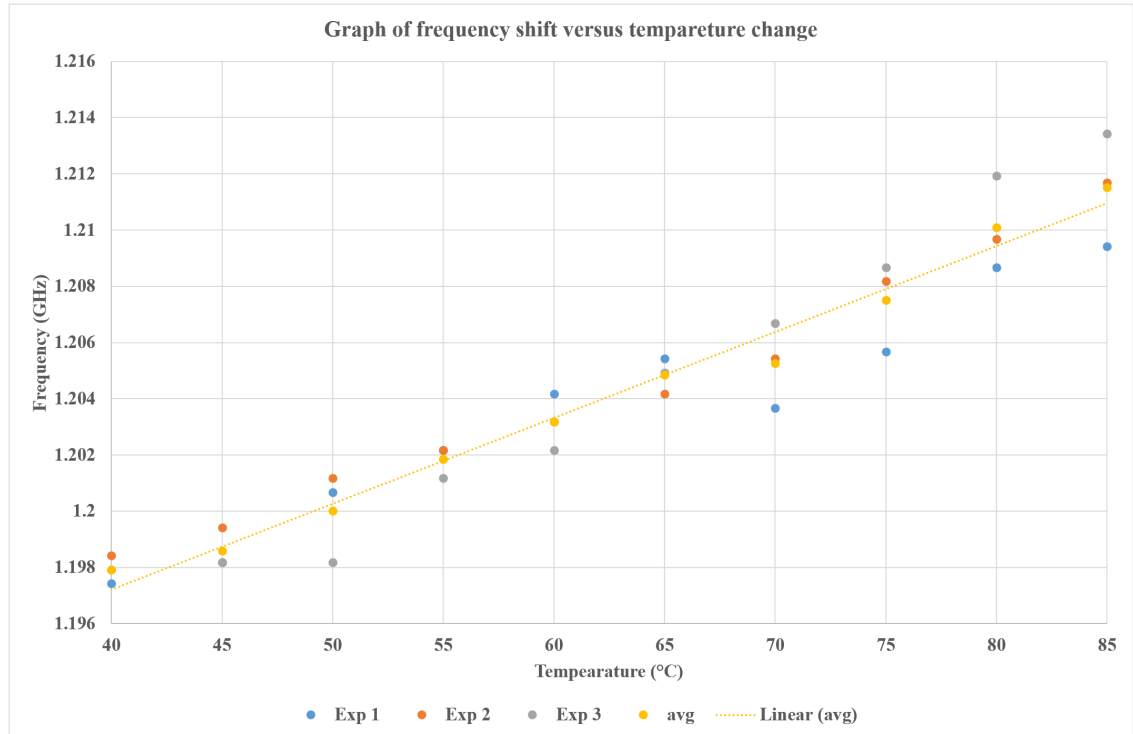

Figure 4.26. Graph of frequency shift versus temperature change.

Table 4.3. Average frequency and standard deviation for each temperature

Temperature (°C)	Average (GHz)	Standard Deviation (MHz)
85	1.211	1.638
80	1.21	1.359
75	1.208	1.313
70	1.205	1.231
65	1.205	0.514
60	1.203	0.471
55	1.202	0.471
50	1.2	1.313
45	1.199	0.589
40	1.198	0.408

- The frequency increases consistently when the temperature increases from 40°C to 85°C in this case, it can be represented using a linear function.

The electromagnetic wave cylindrical cavity sensor demonstrated the ability to detect the high permittivity change, for instance the changes in water level. The electro-

magnetic wave rectangular cavity sensor system is introduced to pick up the tiny shifts in the permittivity when the low permittivity material is used or temperature changes. The microwave sensor system is able to detect water-air fraction, water-oil fraction, oil-air fraction and water temperature.

4.10 Summary

The electromagnetic waves ranging from 5GHz up to 5.7GHz for cylindrical cavity sensor and 1GHz to 1.25GHz for rectangular cavity have been used to analyze the two phase fluid fraction in a pipeline. Labview software is utilized to capture and process the data, and display the results in real time. The temperature independent study have been carried out and shown not to affect the accuracy of the system, despite the permittivity of the water changing. This is assumed to be due to the different overlapping modes negating the affect. While the cylindrical cavity sensor is used to detect the water level independent to the temperature change. The rectangular cavity sensor is responsible for picking up the tiny shifts in the permittivity when the temperature change or low permittivity material is used. The microwave sensor system is able to detect water-air fraction, water-oil fraction, oil-air fraction and water temperature.

Overall, the novel solution of the combination of both cylindrical and rectangular sensor systems demonstrates the ability to detect both high and low permittivity changes. These dual-cavity sensor cavity systems have been able to detect water level, flow regime and temperature in the pipe. This research demonstrates the suitability of using microwave sensors in the analysis of two phase systems. It also demonstrate that microwave sensors based on the principle of changing permittivity can replace conventional measurement techniques.

CHAPTER 5: CONCLUSION AND FUTURE WORK

5.1 Conclusion

An electromagnetic sensor cavity have been developed to detect multiphase flow in this research. It is shown that the cylindrical cavity with the electromagnetic waves ranging from 5 GHz to 5.7 GHz was able to detect two phase stratified flow systems of water, air-water and oil-water in a pipeline. The change in the permittivity of the fluids was used to differentiate between the changing volume fractions of water, oil and gas.

In order to analysis and interpret the data efficiently, an innovative approach is introduced by modelling all the data collected using an mathematical interpretation. Labview software was selected to capture and analyze the data for real time monitoring. Instead of storing all the data, the new approach identified the interested points and represented them using a mathematical equation. The new approach uses shorter time, less computational power and substantially reduces the error of comparing the stored data and newly obtained data.

The sensor also successfully demonstrated its capability to analyze various fractions of gas-water mix. The results were consistent in the case of both the static and dynamic flow. The statistical analysis of the captured data showed a linear relationship of the amplitude data with the change in the water fractions. It was also found that the technique was independent of the temperature change. The change in the temperature didn't affect the accuracy of the system despite the permittivity of the water changing. The system was able to successfully detect the stratified, wavy, elongated bubbles and homogeneous flow regimes. Based on the results obtained it is recommended that the microwave based sensors have a potential to accurately determine various parameters in the case of flow regime measurements. The sensor and the technique can be developed further as a stable and reliable option for the industry.

While the cylindrical cavity sensor is used to detect the water level independent of the temperature change the rectangular cavity sensor is introduced to pick up the tiny shifts in the permittivity when the temperature change or low permittivity material is used. The microwave sensor system is able to detect water-air fraction, water-oil fraction, oil-air fraction and water temperature.

Overall, the novel solution of combination of both cylindrical and rectangular sensor systems demonstrates the ability to detect both high and low permittivity changes. These dual-cavity sensor cavities as shown in figure 5.1 have been able to detect water level, flow regime and temperature in the pipe. This research demonstrates the suitability of using microwave sensors in the analysis of two phase systems. It also demonstrates that microwave sensors based on the principle of changing permittivity can replace conventional measurement techniques.

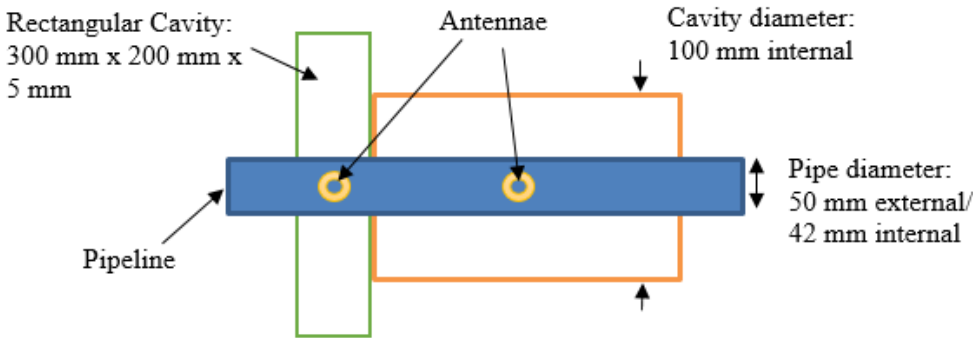

Figure 5.1. Dual microwave sensor cavity system.

5.1.1 Objective achieved

The aims of the present research work conducted were based on the objective proposed. A total of five objectives have been devised for this research work. Based on the results and analysis from the data collected, the following conclusion have been made.

- The sensor is successfully tested in static and stratified condition (water-air and water-oil) and the results obtained is almost identical, the flowing fluid does not affect the two phase detection.
- The effect of temperature on the above measurements were limited, it is found that the temperature does not effect the peak of the amplitude and frequency at 5-5.7GHz especially for 100% water inside the pipe.
- An experimental test rig is constructed for continuous two phase flow detection, is is concluded that the sensor is able to detect different flow regimes.
- Comsol simulations is conducted to compare the experimental and simulations results, both the experimental and simulations results exhibit the same trend and the errors were within acceptable range.
- An novel approach by introducing a rectangular sensor for low permitivity detection is carried out and experimented. The sensor was tested under stratified condition (oil-air) and the system was able to detect low permitivity change. Further testing shows the system can also be use to detect the water temperature in real time.

Finally, all the objectives proposed have been achieved, however, more experiments are needed to carry out in the future for improvement and commercialize purposes.

5.2 Recommendation

The current study only focuses on the laboratory scale of experimental set up. Further study using industrial standards is recommended. The dual microwave cavity sensor demonstrated the ability to detect both high permittivity change and tiny shifts in the permittivity when the temperature change or low permittivity material is used. It is recommended that the system is tested for industrial applications. Although the scale will affect the frequency range, the cavities can be redesigned to suit the industrial piping standard. Microwave cavity sensor method is also recommended for commercial application for two phase flow detection. It is a viable detection technique given its superiority in terms of cost, simplicity and real time analysis compared to the conventional approach.

Further research is required to establish the validity that dual microwave cavity sensors are robust and highly suitable for industrial application. It is also recommended to compare this with the existing flow meter in industrial scale to demonstrate that the invention is superior to the conventional flow meter as this will impact on the demand and marketability of this product.

One of the major problems faced by today's water treatment industry is how to detect low concentrations of nutrients in real time before discharge to the environment. This technology is vital for the industry to avoid environmental pollution and hefty fine. Present research is highly applicable to solve the problem in water treatment industry; the system is capable of detecting low and high permittivity change. The treated water can run continuous through the pipe and the detection can be carried out in real time and no human intervention is required. Further study using dual microwave cavity sensor in this area is highly recommended.

5.3 Future work

On the basis of this experimental study, future work is recommended to fulfill the industrial requirements. Hence, it is recommended that:

- A detailed temperature study of both the two phase and three phase systems is required. This is to evidence the temperature dependence of the technique as well as to verify the claim made in this research work. This can also include fractions in various uneven percentages to replicate the real-world conditions where the percentages of the water-air-oil can vary in the mix.
- An intelligent software system is recommended to be built in the future study. The database would capture all the spectra to match the measurements in later stage and to verify the accuracy, repeatability and versatility of the sensing system.
- A standard operation procedure is to be proposed to address the limitations in the current study in terms of measurements and to remove any anomalies and errors in the measurements. For instance, wet gas is easily found in oil and gas production, the system should be calibrated to detect both the wet and dry gas.
- It is also important to relate more complex properties of the two or three phase fractions to the spectra obtained. Three phase flow experimental set up should be used to analyze the accuracy of present Dual Microwave cavity sensor.

REFERENCES

- Abbagoni, B. M., & Yeung, H. (2016). Non-invasive classification of gas–liquid two-phase horizontal flow regimes using an ultrasonic doppler sensor and a neural network. *Measurement Science and Technology*, 27(8), 084002.
- Abdou, A., Shaw, A., Cullen, J., Wylie, S., Mason, A., & Al-Shamma, A. (2011). *A review of underwater em wave propagation to investigate the development of a through water wsn. 6th built environment and natural environment*. LJMU.
- Abdou, A., Shaw, A., Mason, A., Al-Shamma'a, A., Cullen, J., & Wylie, S. (2011). Electromagnetic (em) wave propagation for the development of an underwater wireless sensor network (wsn). In *Sensors, 2011 ieee* (pp. 1571–1574).
- Abdou, A., Shaw, A., Mason, A., Al-Shamma'a, A., Cullen, J., Wylie, S., & Diallo, M. (2013). A matched bow-tie antenna at 433mhz for use in underwater wireless sensor networks. In *Journal of physics: Conference series* (Vol. 450, p. 012048).
- Abdou, A., Shaw, A., Mason, A., Wylie, S., & Cullen, J. (2012). Antennas experiment, design and simulation for underwater em wave propagation at ism frequency bands. *Built Environment and Natural Environment*, 1–6.
- Adous, M., Qufflec, P., & Laguerre, L. (2006). Coaxial/cylindrical transition line for broadband permittivity measurement of civil engineering materials. *Measurement Science and Technology*, 17(8), 2241. Retrieved from <http://stacks.iop.org/0957-0233/17/i=8/a=026>
- Agar, J. (1992, March 31). *Oil/water measurement*. Google Patents. (US Patent 5,101,163)
- Al-Dasoqi, N. (2012). *The development of an online real time sensor for determining nutrient concentration level in wastewater* (Unpublished doctoral dissertation). Liverpool John Moores University.
- Al-Dasoqi, N., Mason, A., Alkhaddar, R., Shaw, A., & Al-Shamma'a, A. (2011). Real-time non-destructive microwave sensor for nutrient monitoring in wastewater treatment. *Journal of Physics: Conference Series*, 307(1), 012043. Retrieved from <http://stacks.iop.org/1742-6596/307/i=1/a=012043>
- Al-Hajeri, S., Wylie, S., Shaw, A., & Al-Shamma'a, A. (2009). Real time em waves monitoring system for oil industry three phase flow measurement. In *Journal of physics: Conference series* (Vol. 178, p. 012030).
- Alhajeri, S. H. H. (2010). *Online electromagnetic wave monitoring system for petroleum industry applications* (Unpublished doctoral dissertation). Liverpool John Moores University.
- Ali, A., Hu, B., & Ramahi, O. (2015). Intelligent detection of cracks in metallic surfaces using a waveguide sensor loaded with metamaterial elements. *Sensors*, 15(5), 11402. Retrieved from <http://www.mdpi.com/1424-8220/15/5/11402> doi: 10.3390/

- Al-Kizwini, M., Wylie, S., Al-Khafaji, D., & Al-Shammaa, A. (2013). The monitoring of the two phase flow-annular flow type regime using microwave sensor technique. *Measurement*, 46(1), 45–51.
- Amdal, J., Danielsen, H., Dykesteen, E., Flolo, D., Grendstad, J., Hide, H., . . . Torkildsen, B. (1995). Handbook of multiphase metering. *The Norwegian Society for Oil and Gas Measurement, Oslo, Norway*.
- Amdal, J., Danielsen, H., Dykesteen, E., Flolo, D., Grendstal, J., Hide, H., . . . Torkildsen, B. (n.d.). *Handbook of multiphase metering, 2004*.
- Arora, R. (2009). Production well testing using non-radioactive multiphase flow meters. *Exploration & Production*, 7(1), 86–89.
- Arvoh, B. K., Hoffmann, R., & Halstensen, M. (2012). Estimation of volume fractions and flow regime identification in multiphase flow based on gamma measurements and multivariate calibration. *Flow Measurement and Instrumentation*, 23(1), 56–65.
- Ashton, S., Cutmore, N., Roach, G., Watt, J., Zastawny, H., McEwan, A., et al. (1994). Development and trial of microwave techniques for measurement of multiphase flow of oil, water and gas. In *Spe asia pacific oil and gas conference*.
- Ateeq, M., Senouci, A., Al-Nageim, H., & Al-Shammaa, A. (2012). Microwave spectroscopy for the analysis of absorption properties of treated waste rubber aggregates. *Journal of Hazardous, Toxic, and Radioactive Waste*, 16(4), 334–342.
- Ateeq, M., Wylie, S., Al-Shammaa, A., & Al-Nageim, H. (2012). Microwave spectroscopy: a potential technique to analyse bitumen dielectric and physical properties. *Measurement Science and Technology*, 23(8), 085503.
- Bababjanyan, A., Melikyan, H., Kim, S., Kim, J., K, Lee, & Friedman, B. (2010). Real-time noninvasive measurement of glucose concentration using a microwave biosensor. *Journal of Sensors*, 2010, 7. Retrieved from <http://www.sciencedirect.com/science/article/pii/S0924424716302151> doi: <http://dx.doi:10.1155/2010/452163>
- Basrawi, Y. F., et al. (1999). Crude and hydrocarbon measurement technologies. In *Spe annual technical conference and exhibition*.
- Bjarnadottir, S., Lunde, K., Alvseike, O., Mason, A., & Al-Shamma'a, A. (2015). Assessing quality parameters in dry-cured ham using microwave spectroscopy. *Meat science*, 108, 109–114.
- Blakey, R., Korostynska, O., Mason, A., & Al-Shammaa, A. (2012). Real-time microwave based sensing method for vegetable oil type verification. *Procedia Engineering*, 47, 623–626.
- Blakey, R., Nakouti, I., Korostynska, O., Mason, A., & Al-Shamma'a, A. (2013, Dec).

Real-time monitoring of pseudomonas aeruginosa concentration using a novel electromagnetic sensors microfluidic cell structure. *IEEE Transactions on Biomedical Engineering*, 60(12), 3291-3297. doi: 10.1109/TBME.2013.2268277

Brodwin, M., & Benway, J. (1980). Experimental evaluation of a microwave transmission moisture sensor. *J. Microwave Power*, 15(4), 267–276.

Castro-Giráldez, M., Aristoy, M.-C., Toldrá, F., & Fito, P. (2010). Microwave dielectric spectroscopy for the determination of pork meat quality. *Food research international*, 43(10), 2369–2377.

Castro-Giráldez, M., Botella, P., Toldrá, F., & Fito, P. (2010). Low-frequency dielectric spectrum to determine pork meat quality. *Innovative Food Science & Emerging Technologies*, 11(2), 376–386.

Chen, D., Wang, X., Che, C., Cong, J., Xu, D., & Wang, X. (2010). A transient method for measuring the gas volume fraction in a mixed gas-liquid flow using acoustic resonance spectroscopy. *Science China Physics, Mechanics and Astronomy*, 53(8), 1412–1418.

Colline, R. E. (1992). Foundation for microwave engineering. *McGraw Hill, New York*.

Colpitts, B., Pelletier, Y., & Cogswell, S. (1992). Complex permittivity measurements of the colorado potato beetle using coaxial probe techniques. *Journal of Microwave Power and Electromagnetic Energy*, 27(3), 175–182.

Connor, F. R. (1972). *Signals*. Hodder Arnold.

Corneliussen, S., Couput, J., Dahl, E., Dykestee, E., Frøysa, K., Malde, E., . . . Tunheim, H. (2005). *Handbook of multiphase flow metering, revision 2*. Oslo: Norwegian Society for Oil and Gas Measurement (NFOGM) and The Norwegian Society of Chartered Technical and Scientific Professionals (Tekna).

Da Silva, M. J. (2008). Impedance sensors for fast multiphase flow measurement and imaging.

De Castro, M. S., Pereira, C. C., Dos Santos, J. N., & Rodriguez, O. M. (2012). Geometrical and kinematic properties of interfacial waves in stratified oil–water flow in inclined pipe. *Experimental Thermal and Fluid Science*, 37, 171–178.

Dei, D., Grazzini, G., Luzi, G., Pieraccini, M., Atzeni, C., Boncinelli, S., . . . Lo Dico, J. (2009). Non-contact detection of breathing using a microwave sensor. *Sensors*, 9(4), 2574. Retrieved from <http://www.mdpi.com/1424-8220/9/4/2574> doi: 10.3390/s90402574

Dukler, A. E., & Hubbard, M. G. (1975). A model for gas-liquid slug flow in horizontal and near horizontal tubes. *Industrial & Engineering Chemistry Fundamentals*, 14(4), 337–347.

Dykestee, E., Hallanger, A., Hammer, E., Samnoy, E., & Thorn, R. (1985). Non-intrusive three-component ratio measurement using an impedance sensor. *Journal of*

Physics E: Scientific Instruments, 18(6), 540.

- Evans, D. H., & McDicken, W. N. (2000). *Doppler ultrasound: physics, instrumentation and signal processing*. John Wiley & Sons.
- Falcone, G., Hewitt, G., & Alimonti, C. (2009). *Multiphase flow metering: principles and applications* (Vol. 54). Elsevier.
- Figueiredo, M., Goncalves, J., Nakashima, A., Fileti, A., & Carvalho, R. (2016). The use of an ultrasonic technique and neural networks for identification of the flow pattern and measurement of the gas volume fraction in multiphase flows. *Experimental Thermal and Fluid Science*, 70, 29–50.
- Fok, M., Bashir, M., Fraser, H., Strouther, N., & Mason, A. (2015). A novel microwave sensor to detect specific biomarkers in human cerebrospinal fluid and their relationship to cellular ischemia during thoracoabdominal aortic aneurysm repair. *Journal of Medical Systems*, 39(4), 1–5. Retrieved from <http://dx.doi.org/10.1007/s10916-015-0208-4> doi: 10.1007/s10916-015-0208-4
- Fulladosa, E., Duran-Montg, P., Serra, X., Picouet, P., Schimmer, O., & Gou, P. (2013). Estimation of dry-cured ham composition using dielectric time domain reflectometry. *Meat Science*, 93(4), 873 - 879. Retrieved from <http://www.sciencedirect.com/science/article/pii/S030917401200410X> doi: <http://dx.doi.org/10.1016/j.meatsci.2012.12.002>
- Gaisford, G. S. (2001, February 6). *Emulsion composition monitor*. Google Patents. (US Patent 6,182,504)
- Georgiadou, E., Panagopoulos, A., & Kanellopoulos, J. (2006). Millimeter wave pulse propagation through distorted raindrops for los fixed wireless access channels. *Journal of Electromagnetic Waves and Applications*, 20(9), 1235–1248.
- Gokcal, B., Al-Sarkhi, A. S., Sarica, C., et al. (2009). Effects of high oil viscosity on drift velocity for horizontal and upward inclined pipes. *SPE Projects, Facilities & Construction*, 4(02), 32–40.
- Goncalves, J., Paiva, T., Abud, J., Carvalho, R., Venturini, O., et al. (2011). Development of a multiphase flow metering procedure based on the ultrasonic technique. In *15th international conference on multiphase production technology*.
- Hammer, E. A., & Johansen, G. A. (1997). Process tomography in the oil industry: state of the art and future possibilities. *Measurement and Control*, 30(7), 212–216.
- Hapanowicz, J. (2008). Slip between the phases in two-phase water–oil flow in a horizontal pipe. *International Journal of Multiphase Flow*, 34(6), 559–566.
- Hasted, J. B. (1973). *Aqueous dielectrics*. Chapman and Hall.
- Hernandez, L., Julia, J., Chiva, S., Paranjape, S., & Ishii, M. (2006). Fast classification of two-phase flow regimes based on conductivity signals and artificial neural networks. *Measurement Science and Technology*, 17(6), 1511.

- Hewitt, G. (1997a). Gas-liquid-liquid flow: A phase too far? In *Bhr group conference series publication* (Vol. 24, pp. 215–240).
- Hewitt, G. (1997b). Keynote speech: " gas-liquid-liquid flow: a phase too far. In *Proceedings bhr conference multiphase* (Vol. 97, pp. 215–239).
- Höhne, T., & Mehlhoop, J.-P. (2014). Validation of closure models for interfacial drag and turbulence in numerical simulations of horizontal stratified gas–liquid flows. *International Journal of Multiphase Flow*, 62, 1–16.
- Huh, D., Kuo, C., Grotberg, J., & Takayama, S. (2009). Gas–liquid two-phase flow patterns in rectangular polymeric microchannels: effect of surface wetting properties. *New journal of physics*, 11(7), 075034.
- Ismail, I., Gamio, J., Bukhari, S. A., & Yang, W. (2005). Tomography for multi-phase flow measurement in the oil industry. *Flow Measurement and Instrumentation*, 16(2), 145–155.
- Jain, A. K., Duin, R. P. W., & Mao, J. (2000). Statistical pattern recognition: A review. *IEEE Transactions on pattern analysis and machine intelligence*, 22(1), 4–37.
- Kapilevich, B., & Litvak, B. (2007). Microwave sensor for accurate measurements of water solution concentrations. In *2007 asia-pacific microwave conference* (pp. 1–4).
- Kesana, N. R., Parsi, M., Vieira, R. E., Azzopardi, B., Schleicher, E., McLaury, B. S., . . . Hampel, U. (2017). Visualization of gas-liquid multiphase pseudo-slug flow using wire-mesh sensor. *Journal of Natural Gas Science and Engineering*.
- Klein, A. (1981). Microwave determination of moisture in coal. comparison of attenuation and phase measurement. *Journal of Microwave Power*, 16(3&4), 289–304.
- Kolev, N. I. (2005). *Multiphase flow dynamics: Fundamentals*. Springer.
- Korostynska, O., Mason, A., & Al-Shamma'a, A. (2014). Microwave sensors for the non-invasive monitoring of industrial and medical applications. *Sensor Review*, 34(2), 182-191. Retrieved from <http://dx.doi.org/10.1108/SR-11-2012-725> doi: 10.1108/SR-11-2012-725
- Korostynska, O., Mason, A., & Al-Shammaa, A. I. (2013). Flexible microwave sensors for real-time analysis of water contaminants. *Journal of Electromagnetic Waves and Applications*, 27(16), 2075–2089.
- Korostynska, O., Mason, A., Ortoneda-Pedrola, M., & Al-Shammaa, A. (2014). Electromagnetic wave sensing of no 3 and cod concentrations for real-time environmental and industrial monitoring. *Sensors and Actuators B: Chemical*, 198, 49–54.
- Korostynska, O., Ortoneda-Pedrola, M., Mason, A., & Al-Shamma'a, A. I. (2014). Flexible electromagnetic wave sensor operating at ghz frequencies for instantaneous concentration measurements of nacl, kcl, mncl₂ and cucl solutions. *Measurement Science and Technology*, 25(6), 065105. Retrieved from <http://stacks.iop.org/>

- Kouamé, D., Girault, J.-M., Remenieras, J.-P., Chemla, J.-P., & Lethiecq, M. (2003). High resolution processing techniques for ultrasound doppler velocimetry in the presence of colored noise. ii. multiplephase pipe-flow velocity measurement. *IEEE transactions on ultrasonics, ferroelectrics, and frequency control*, 50(3), 267–278.
- Kntor, Z., & Plik, Z. (2016). Artificial neural network assisted compact inductive distance sensor. *Procedia Engineering*, 168(Supplement C), 23 - 26. Retrieved from <http://www.sciencedirect.com/science/article/pii/S1877705816334300> (Proceedings of the 30th anniversary Eurosensors Conference Eurosensors 2016, 4-7. September 2016, Budapest, Hungary) doi: <https://doi.org/10.1016/j.proeng.2016.11.121>
- Li, Y., Yang, W., Xie, C.-g., Huang, S., Wu, Z., Tsamakidis, D., & Lenn, C. (2013). Gas/oil/water flow measurement by electrical capacitance tomography. *Measurement Science and Technology*, 24(7), 074001.
- Lu, G., Yang, F., Tian, Y., Jing, X., & Wang, J. (2009). Contact-free measurement of heart rate variability via a microwave sensor. *Sensors*, 9(12), 9572. Retrieved from <http://www.mdpi.com/1424-8220/9/12/9572> doi: 10.3390/s91209572
- Mason, A., Abdullah, B., Muradov, M., Korostynska, O., Al-Shammaa, A., Bjarnadottir, S. G., ... Alvseike, O. (2016). Theoretical basis and application for measuring pork loin drip loss using microwave spectroscopy. *Sensors*, 16(2), 182.
- Mason, A., Korostynska, O., Ortoneda-Pedrola, M., Shaw, A., & Al-Shamma'a, A. (2013). A resonant co-planar sensor at microwave frequencies for biomedical applications. *Sensors and Actuators A: Physical*, 202, 170 - 175. Retrieved from <http://www.sciencedirect.com/science/article/pii/S0924424713001799> (Selected Papers from the 26th European Conference on Solid-State Transducers Krakow, Poland, 9-12 September 2012) doi: <http://dx.doi.org/10.1016/j.sna.2013.04.015>
- Mason, A., Korostynska, O., Wylie, S., & Al-Shamma'a, A. (2014). Non-destructive evaluation of an activated carbon using microwaves to determine residual life. *Carbon*, 67, 1 - 9. Retrieved from <http://www.sciencedirect.com/science/article/pii/S0008622312005404> doi: <http://dx.doi.org/10.1016/j.carbon.2012.06.034>
- Mason, A., Wylie, S., Korostynska, O., Cordova-Lopez, L., & Al-Shammaa, A. (2014). Flexible e-textile sensors for real-time health monitoring at microwave frequencies. *International Journal on Smart Sensing and Intelligent Systems*, 7(1), 31–47.
- Mehdizadeh, P., Farchy, D., et al. (1995). Multi-phase flow metering using dissimilar flow sensors: theory and field trial results. In *Middle east oil show*.
- Mi, Y., Ishii, M., & Tsoukalas, L. (2001). Flow regime identification methodology with neural networks and two-phase flow models. *Nuclear Engineering and Design*, 204(1), 87–100.
- Mukhopadhyay, S. C., Mason, A., et al. (2013). *Smart sensors for real-time water quality monitoring*. Springer.

- Muradov, M., Cullen, J., & Mason, A. (2016). Real-time monitoring of meat drying process using electromagnetic wave sensors. In *Next generation sensors and systems* (pp. 221–233). Springer.
- Murai, Y., Tasaka, Y., Nambu, Y., Takeda, Y., et al. (2010). Ultrasonic detection of moving interfaces in gas–liquid two-phase flow. *Flow Measurement and Instrumentation*, 21(3), 356–366.
- Nyfors, E., & Vainikainen, P. (1989). *Industrial microwave sensors*. Artech House Publishers.
- Oon, C., Ateeq, M., Shaw, A., Al-Shammaa, A., Kazi, S., & Badarudin, A. (2016). Experimental study on a feasibility of using electromagnetic wave cylindrical cavity sensor to monitor the percentage of water fraction in a two phase system. *Sensors and Actuators A: Physical*, 245, 140–149.
- Oon, C. S., Ateeq, M., Shaw, A., Wylie, S., Al-Shammaa, A., & Kazi, S. N. (2016). Detection of the gas–liquid two-phase flow regimes using non-intrusive microwave cylindrical cavity sensor. *Journal of Electromagnetic Waves and Applications*, 1–15.
- Ozbayoglu, E., & Ozbayoglu, M. (2009). Estimating flow patterns and frictional pressure losses of two-phase fluids in horizontal wellbores using artificial neural networks. *Petroleum Science and Technology*, 27(2), 135–149.
- OConnor, E., Smeaton, A. F., OConnor, N. E., & Regan, F. (2012). A neural network approach to smarter sensor networks for water quality monitoring. *Sensors*, 12(4), 4605–4632. Retrieved from <http://www.mdpi.com/1424-8220/12/4/4605> doi: 10.3390/s120404605
- Poette, C., & Reynier, P. (2014). Evaluation of 3d mapping experimental non-intrusive methods for multiphase flows. *The International Journal of Multiphysics*, 8(1), 69–90.
- Prasser, H.-M., Böttger, A., & Zschau, J. (1998). A new electrode-mesh tomograph for gas–liquid flows. *Flow measurement and instrumentation*, 9(2), 111–119.
- Qu, Z., Zhao, Q., & Meng, Y. (2013). Online measurement of water concentration of oil–water mixtures in the flow of pipeline by using eddy current method. *Measurement Science and Technology*, 24(12), 125304.
- Rao, Y., Wang, S., Zhou, S., Yu, Y., & Wei, M. (2011). Reviewed of gas-liquid two-phase flow pattern in level and inclined tube. In *Computational and information sciences (iccis), 2011 international conference on* (pp. 563–566).
- Roach, G., & Watt, J. (1996). Current status of development of the csiro gamma-ray multiphase flow meter. In *Proc. 14th north sea flow measurement workshop*.
- Rodriguez, O., & Oliemans, R. (2006). Experimental study on oil–water flow in horizontal and slightly inclined pipes. *International Journal of Multiphase Flow*, 32(3), 323–343.

- Santhosh, K., & Roy, B. (2012). An intelligent flow measurement technique using ultrasonic flow meter with optimized neural network. *International Journal of Control and Automation*, 5(4), 185–195.
- Scheers, A. (2001). Multi-phase flow metering... on it's way from nursing to mature technology. *Shell report*.
- Scheffler, M. (2004). Broadband microwave spectroscopy on correlated electrons.
- Scott, B., Cregger, B., Shortes, S., et al. (1993). Technology for full-range water-cut measurements. In *Offshore technology conference*.
- Shaw, A., Wylie, S., Toal, D., et al. (2006). Experimental investigations of electromagnetic wave propagation in seawater. In *2006 european microwave conference* (pp. 572–575).
- Stuchly, S., & Stuchly, M. (1999). Coaxial line reflection method for measuring dielectric properties at radio and microwave frequencies, a review. *IEEE Trans. Instrum. Meas.*, 29(3), 1640–1648.
- Sun, Z., & Zhang, H. (2007). Neural networks approach for prediction of gas–liquid two-phase flow pattern based on frequency domain analysis of vortex flowmeter signals. *Measurement Science and Technology*, 19(1), 015401.
- Sunde, C., Avdic, S., & Pázsit, I. (2005). Classification of two-phase flow regimes via image analysis and a neuro-wavelet approach. *Progress in Nuclear Energy*, 46(3), 348–358.
- Taitel, Y., & Dukler, A. (1976). A model for predicting flow regime transitions in horizontal and near horizontal gas-liquid flow. *AIChE Journal*, 22(1), 47–55.
- Tan, C., Wu, H., & Dong, F. (2013). Horizontal oil–water two-phase flow measurement with information fusion of conductance ring sensor and cone meter. *Flow Measurement and Instrumentation*, 34, 83–90.
- Thorn, R., Johansen, G., & Hammer, E. (1997). Recent developments in three-phase flow measurement. *Measurement Science and Technology*, 8(7), 691.
- Thorn, R., Johansen, G., & Hjertaker, B. (2012). Three-phase flow measurement in the petroleum industry. *Measurement Science and Technology*, 24(1), 012003.
- Übeyli, E. D., & Güler, İ. (2005). Improving medical diagnostic accuracy of ultrasound doppler signals by combining neural network models. *Computers in Biology and Medicine*, 35(6), 533–554.
- Wang, H., Priestman, G., Beck, S., & Boucher, R. (1998). A remote measuring flow meter for petroleum and other industrial applications. *Measurement Science and Technology*, 9(5), 779.
- Wellock, R., & Walmsley, A. D. (2004). Applications of microwave spectroscopy in process analysis. *Spectroscopy Europe*, 16(4), 23–26.

- Wylie, S., Shaw, A., & Al-Shamma'a, A. (2006). Rf sensor for multiphase flow measurement through an oil pipeline. This paper was presented at the 13th international conference on sensors and held in Chatham, Kent, on 6–7 September 2005. *Measurement Science and Technology*, 17(8), 2141.
- Wylie, S. R., Shaw, A., & Al-Shamma'a, A. I. (2006). Rf sensor for multiphase flow measurement through an oil pipeline. *Measurement Science and Technology*, 17(8), 2141. Retrieved from <http://stacks.iop.org/0957-0233/17/i=8/a=013>
- Xie, T., Ghiaasiaan, S., & Karrila, S. (2004). Artificial neural network approach for flow regime classification in gas–liquid–fiber flows based on frequency domain analysis of pressure signals. *Chemical Engineering Science*, 59(11), 2241–2251.
- Xu, J.-y., Wu, Y.-x., Feng, F.-f., Chang, Y., & Li, D.-h. (2008). Experimental investigation on the slip between oil and water in horizontal pipes. *Experimental Thermal and Fluid Science*, 33(1), 178–183.
- Xu, X.-X. (2007). Study on oil–water two-phase flow in horizontal pipelines. *Journal of Petroleum Science and Engineering*, 59(1), 43–58.

LIST OF PUBLICATIONS AND PAPER PRESENTED

Journal Publication

- 1 C. S. Oon, M. Ateeq, A. Shaw, S. Wylie, A. Al-Shamma'a, S. N. Kazi. Detection of the Gas-Liquid Two-Phase Flow Regimes Using Non-intrusive Microwave Cylindrical Cavity Sensor. *Journal of electromagnetic waves & applications*, Volume 30, Issue 17, November 2016, Pages 2241-2255.
- 2 C.S. Oon, M. Ateeq, A. Shaw, A. Al-Shamma'a, S.N. Kazi, A. Badarudin. Experimental study on a feasibility of using electromagnetic wave cylindrical cavity sensor to monitor the percentage of water fraction in a two phase system. *Sensors and Actuators A: Physical*, Volume 245, 1 July 2016, Pages 140–149
- 3 C.S. Oon, A. Al-Shamma'a, S.N. Kazi, B.T. Chew, A. Badarudin, E. Sadeghinezhad. Simulation of heat transfer to separation Air flow in a concentric pipe. *International Communications in Heat and Mass Transfer*, Volume 57, October 2014, Pages 48-52.
- 4 C.S.Oon, A. Badarudin, S.N. Kazi, M. Fadhli. Simulation of Heat Transfer to Turbulent Nanofluid Flow in an Annular Passage. *Advanced Materials Research*, Volume 925, 2014 Pages 625-629.
- 5 E. Sadeghinezhad, M Mehrali, S.T. Latibari, M. Mehrali, S. N. Kazi, C.S. Oon, H.S.C. Metselaar. Experimental Investigation of Convective Heat Transfer Using Graphene Nanoplatelet Based Nanofluids under Turbulent Flow Conditions. *Industrial & Engineering Chemistry. Research.*, 2014, Volume 53, Issue 31, Pages 12455–12465
- 6 Emad Sadeghinezhad, Salim N. Kazi, Ahmad Badarudin, Hussein Togun, Mohd N.M. Zubir, Cheen S. Oon, Samira Gharehkhani. Sustainability and environmental impact

- of ethanol as a biofuel, *Reviews in Chemical Engineering*. Volume 30, Issue 1, Pages 51–72.
- 7 E. Sadeghinezhad, S.N. Kazi, A. Badarudin, C.S. Oon, M.N.M. Zubir, Mohammad Mehrli. A comprehensive review of bio-diesel as alternative fuel for compression ignition engines. *Renewable and Sustainable Energy Reviews*, Volume 28, December 2013, Pages 410–424.
 - 8 Ahmad Badarudin Mohamad Badry, Yin-Jen Lee, Wen-Tong Chong, Nik-Nazri Nik-Ghazali, Cheen-Sean Oon, Kazi Salim Newaz. Numerical analysis of the effect of vortex control mechanism on longitudinal aerodynamics of lifting body. *Aerospace Science and Technology*, Volume 30, Issue 1, October 2013, Pages 232–238.
 - 9 C.S. Oon, Hussein Togun, S.N. Kazi, A. Badarudin, E. Sadeghinezhad. Computational simulation of heat transfer to separation fluid flow in an annular passage. *International Communications in Heat and Mass Transfer*, Volume 46, August 2013, Pages 92-96.
 - 10 W.T. Chong, K.C. Pan, S.C. Poh, A. Fazlizan, C.S. Oon, A. Badarudin, N. Nik-Ghazali. Performance investigation of a power augmented vertical axis wind turbine for urban high-rise application. *Renewable Energy*, Volume 51, March 2013, Pages 388-397.
 - 11 E. Sadeghinezhad, S.N. Kazi, A. Badarudin, C.S. Oon, M.N.M. Zubir, Mohammad Mehrli. A comprehensive review of bio-diesel as alternative fuel for compression ignition engines. *Renewable and Sustainable Energy Reviews*, Volume 28, December 2013, Pages 410-424.
 - 12 C.S. Oon, Hussein Togun, S.N. Kazi, A. Badarudin, M.N.M. Zubir, E. Sadeghinezhad. Numerical simulation of heat transfer to separation air flow in an annular pipe. *Intern-*

tional Communications in Heat and Mass Transfer, Volume 39, Issue 8, October 2012,
Pages 1176-1180.

Conference Publication

- 1 Experiment Verification of Fluid Fraction and Temperature Detection Using Cylindrical and Rectangular Microwave Cavity Sensor System. Faculty Research Week 2016, Liverpool, UK, 9-13 May 2016. (Oral Presentation)
- 2 Electromagnetic Wave Sensor for Multiphase Flow Measurement in the Oil and Gas Industry. Bean Conference 2014, Liverpool John Moores University, UK, 18 June 2014. (Poster Presentation)
- 3 Comsol Conference 2014 Cambridge, University of Cambridge, UK, 17-19 September 2014 (Participate)
- 4 Numerical Simulation of Heat Transfer to Separation TiO₂/Water Nanofluids flow in an Asymmetric Abrupt Expansion. Experimental Fluid Mechanics 2014, Cesky Krumlov, Czech Republic. 18-21 November 2014. (Poster Presentation)
- 5 Electromagnetic Wave Sensor for Temperature Independent Multiphase Flow Measurement. Faculty Research Week 2015, Liverpool John Moores University, UK, 15-19 June 2015. (Oral and Poster Presentation)
- 6 Numerical Simulation of Heat transfer to TiO₂-water nanofluid flow in a double-tube counter flow heat exchanger. International Conference on Clean Energy 2014. Istanbul Turkey. 8-12 June 2014. (Oral Presentation)
- 7 Numerical Investigation of Heat Transfer to Fully Developed Turbulent Air Flow in a Concentric Pipe. Fifth International Conference on Computational Intelligence, Modelling and Simulation (CIMSIM 2013, IEEE Proceeding). Seoul, South Korea. 24-26 September 2013. (Oral Presentation)

- 8 Simulation of Heat Transfer to Turbulent Nanofluid Flow in an Annular Passage. Joint International Conference on Nanoscience, Engineering and Management (BOND21). Penang, Malaysia. 19-21 August 2013. (Oral Presentation)
- 9 Simulation of Heat Transfer to Turbulent Air Flow in an Annular Passage. 2nd International Conference on Mechanical, Automotive and Aerospace Engineering (ICMAAE 2013) Kuala Lumpur, Malaysia. 2-4 July 2013. (Oral Presentation)
- 10 Numerical Simulation and Experiment of a Lifting Body with Leading-edge Rotating Cylinder. International Conference on Mechanical, Materials and Mechatronics Engineering (ICMMME 2013). Madrid, Spain. 28-29 March 2013. (Oral Presentation)
- 11 A Computational Simulation of Heat Transfer to Separation Air Flow in a Concentric Pipe. International Conference on Applications and Design in Mechanical Engineering (ICADME). Penang, Malaysia. 27-28 February 2012. (Oral Presentation)
- 12 Vertical axis wind turbine with omni-directional-guide-vane for urban high rise application. International Conference of WREC-Asia & SuDBE2011, Chongqing, China. 28-31 October 2011.
- 13 Exhaust Air and Wind Energy Recovery system for Clean Energy Generation. Proceedings of International Conference on Environment and Industrial Innovation (ISI Proceedings). Kuala Lumpur. 4-5 June 2011.

Appendices

APPENDIX A AWARD

Award

- 1 Associate Fellow of The Higher Education Academy (UK Professional Standards Framework for teaching and learning support in higher education) 2015
- 2 Dual-Phd Scholarship 2013
- 3 Gold Medal Award – Malaysia Technology Expo 2011
- 4 University of Malaya Fellowship Scheme (Skim Biasiswazah) 2011

APPENDIX B PATENT

Patent: Dual Microwave Cavity Sensor System

Title of Invention: Dual Microwave Cavity Sensor System

Application Status: Pending Filing

FIELD OF THE INVENTION

The present invention relates to a multiphase flow metering system for measuring of the mixture proportions within fluids. More particularly, the present invention relates to a multiphase flow metering system, an apparatus and measuring method for continuous, real-time measurement of the mixture proportions within fluids.

BACKGROUND OF THE INVENTION

Several meters for measuring of the mixture proportions within fluids, such as, water contents in oil, are available on the market today. Some of these meters are based on the use of radioactive radiation, some of them are capacitive and some are based on use of microwaves. Radioactive sensors are not acceptable or rather controversial in many environments due to the health hazard represented by the radiation, and the required security precautions. Sufficient accuracy also represents a problem in radioactive sensors as the radiation is most sensible for variations in density, and the difference in density between water and oil is rather low. The capacitive meters detect the permittivity of the mixture of fluids at a frequency much lower than the frequency regularly used in sensors based upon microwaves. Such sensors are rather sensitive for different coatings as a large increase of the impedance will be the result of even a thin coating. The capacitive sensors also require a relatively complex design using a dielectric internal protection in the sensor to avoid direct contact between the electrodes and the fluid or the liquid, which is to be measured. The above problems are not involved with the microwave sensors.

The electrical permittivity of a nominally homogeneous mixture depends upon the volumetric ratio of the constituent materials and upon the permittivity of the individual components. Microwave instruments exploit this fact to analyze the properties of substances or the composition of mixtures by measuring and analyzing various attributes of a microwave signal or set of signals that depend directly upon the permittivity of the substance or mixture. For example, instruments in a variety of configurations are available which measure the attenuation or phase shift of signals that are transmitted through an unknown mixture.

It is crucial to measure gas or liquid fraction, phase velocities and the water-in-liquid ratio (WLR), in order to acquire the production flow rates of oil and water. Several

Multi Phase Flow Meters (MPFMs) have been designed and developed by companies and research organizations, utilizing various measurement technologies. Although those MPFMs are commercially available, there are number of challenging problems yet to be solved, for instance, different flow regimes, changes in the fluid properties and sensitivity of the measurement of phase-fraction.

U.S. Pat. No. US 5083089 A issued to Spatial Dynamics, Ltd discloses an apparatus and associated measuring method for monitoring the dielectric constants of the fluid ingredients in a heterogeneous mixture flowing through a conduit and thereby measuring the relative volume of each of the constituents of the mixture. The apparatus includes a microwave source generating microwaves at a predetermined frequency along an axis and a measuring means for measuring the reflected microwave along that axis. The apparatus further includes a transmitter/receiver lens, which is a part of the microwave source, capable of radiating microwave energy at a predetermined frequency along the above said axis and also capable of measuring the reflected microwaves along the axis. The apparatus further includes a cylindrical cavity surrounding the conduit through which the fluid mixture passes. The reflected microwaves from the heterogeneous fluid mixture passing through the conduit are received by the microwave energy receiver and is analyzed, which in the end provides a volumetric ratio between the oil and water constituents of the fluid mixture passing through the conduit.

Another prior art EP 1082606 B1 titled “Microwave fluid sensor and a method for using same”, issued to Multi-Fluid Asa discloses a microwave sensor capable of measuring relative portions of fluids in a fluid mixture passing through a tube having radially extending, conducting internal fins along an axis of the tube. The length of the tube is utilized as a part of the sensor. A number of sensor probes are also provided in the tube for transmitting electromagnetic energy in the microwave region into the sensor and for receiving the microwave energy from the sensor. The sensor employs a resonant frequency

below a cut-off frequency of the tube to measure the contents in the tube. The method of measuring the relative proportions of the constituents of the fluid mixture passing through the tube includes the steps of determining the resonant frequency of the microwave signals generated by the sensor and calculating the permittivity of the fluid constituents from the resonant frequency. The measured permittivity is then compared with standard permittivity of known fluids and then analyzed to determine the relative proportions of the constituents.

Another prior art WO 2007129901 A1 titled “Method and Apparatus for Measuring the Conductivity of the Water Fraction of a Wet Gas” issued to Arnstein Wee discloses a method and apparatus for determining the water conductivity of a multi-component mixture of gas and one or more liquid containing water in a pipe is proposed. The proposed method includes the steps of performing electromagnetic measurements at least two measurement frequencies, within the range of within the range of 1 MHz to 10000 MHz, in a pipe near the pipe wall at a first cross-sectional location where the mixture predominantly contains gas and at a second cross-sectional location where the mixture predominantly contains liquid. The method further includes the steps of determining the temperature of the multi-component mixture and determining the conductivity of the water in the in the multi-component mixture based on an empirically determined relationship between the measurements performed is the above two steps and the conductivity of pure water.

The above cited prior arts provides non-intrusive and intrusive methods for detecting the fluid constituents in a fluid mixture passing through a tube. However none of the above cited prior arts employ a pair of cavity sensors for performing non-intrusive measurement of fluid compositions, volume fractions and temperature in real-time. The objective of this invention is to enhance the robustness of the real time measurement of oil well streams, to provide a low-cost MPFM solution and to continuously monitor the production of each well.

SUMMARY OF THE INVENTION

The present invention relates to a multiphase flow metering system for measuring the relative volumetric proportions and temperature of a number of constituents present in a fluid mixture passing through a pipe. The multiphase flow metering system includes an apparatus non-intrusively placed around the pipe carrying the fluid mixture. The apparatus includes a cylindrical cavity structure longitudinally and coaxially placed around the pipe carrying the fluid mixture. The cylindrical cavity structure has a pair of open ends and a diameter larger than the diameter of the pipe and is longitudinally placed around the pipe carrying the fluid mixture. The cylindrical cavity structure includes a first microwave sensor system having a first loop antenna placed on an inner wall of the cylindrical cavity structure and a first electronic means capable of generating microwave signals at a first predetermined frequency. The apparatus further includes a rectangular cavity structure vertically placed across the pipe. The rectangular cavity structure includes a second microwave sensor system having a second loop antenna placed on an inner wall of the rectangular cavity structure and a second electronic means or platform capable of generating electromagnetic signals at a second predetermined frequency. Each of the first loop antenna connected to the first electronic means and the second loop antenna connected to the second electronic means are configured to operate in a two port configuration, i.e. capable of transmission and reception of signals, to transmit and receive the microwave signs within the apparatus. The microwave signals transmitted by the first loop antenna at the first predetermined frequency within the cylindrical cavity structure passes through the constituents of the fluid mixture flowing through the pipe and gets a shift in frequency caused by the difference in permittivity of the constituents present in the fluid mixture. Similarly, the microwave signals transmitted by the second loop antenna at the second predetermined frequency within the rectangular cavity structure passes through

the constituents of the fluid mixture flowing through the pipe and gets a slight shift in frequency caused by the difference in permittivity and temperature variation of the constituents present in the fluid mixture. The attenuated and reflected microwave signals with shifts in frequency from its first predetermined frequency and the second predetermined frequency are detected by the first loop antenna and the second loop antenna, both operating in two-port configuration, respectively. A computer system running a frequency analysis and multiphase flow metering application analyzes the outputs from the first microwave sensor system and the second microwave sensor system to identify the relative volumetric proportion of the constituents in the fluid mixture passing through the pipe in real-time.

Other main features of the present multiphase flow metering system and method are discussed below. The present invention is designed to fulfill the below and other additional features as detailed in the following claims section and detailed description section of the invention.

A primary feature of the invention is to provide a multiphase flow metering system capable of measuring the relative volumetric concentrations of a number of constituents in a fluid mixture passing through a pipe in real-time, continuously.

Another feature of the invention is to provide an apparatus having rectangular and cylindrical cavities capable of non-intrusively placing around the pipe carrying the fluid mixture.

Another feature of the invention is to provide an apparatus having a cylindrical cavity structure longitudinally and coaxially placed around the pipe carrying the fluid mixture.

Another feature of the invention is to provide an apparatus having a rectangular cavity structure vertically placed across the pipe carrying the fluid mixture.

Another feature of the invention is to provide an apparatus having a cylindrical cavity structure with a loop antenna operating in a two-port configuration non-intrusively placed

around the pipe carrying the fluid mixture.

Another feature of the invention is to provide an apparatus having a rectangular cavity structure with a loop antenna operating in a two-port configuration non-intrusively placed across the pipe carrying the fluid mixture.

Another feature of the invention is to provide an apparatus having a cylindrical cavity structure and a rectangular cavity structure capable of creating resonant electromagnetic waves along and across the pipe carrying the fluid mixture.

Another feature of the invention is to provide a computer system running a frequency analysis and multiphase flow metering application to analyze the shift in frequency to determine the relative volumetric proportions and temperature of the constituents in the fluid mixture, in real-time.

Another feature of the invention is to provide a computer system running a frequency analysis and multiphase flow metering application to continually display the relative volumetric proportions of the constituents in the fluid mixture passing through a pipe.

Another feature of the invention is to provide a multiphase flow metering system capable of determining the relative volumetric proportions including water-air fraction, water-oil fraction and oil-air fraction in the fluid mixture having the constituents in form of water, air and oil.

DETAIL DESCRIPTION OF THE INVENTION

The present invention relates to a multiphase flow metering system, a microwave radiating and receiving apparatus and an associated method for measuring the relative volumetric proportions and temperature of a number of constituents present in a fluid mixture passing through a pipe. The present multiphase flow metering system utilizes a non-intrusive microwave sensing method for determining the relative volumetric proportions and temperature of the constituents present in a fluid mixture flowing through a pipe. Further, the present non-intrusive microwave sensing method utilizes the resonant frequencies of microwave signals occurring in an enclosed cavity when microwave signals of a desired frequency are radiated into the cavity. The present multiphase flow metering system and associated measuring method makes use of the fact that the frequency of microwave signals, when passed through a polarizing or dielectric material, changes depending on the permittivity of the material. The apparatus used in the present multiphase flow metering system generates microwave signals at desired frequencies and transmits the microwave signals through the constituents present in the fluid mixture passing through the pipe. The microwave signals within a selected range of frequencies, when generated inside the cavity creates resonance at a particular frequency, and these resonating microwave signals are non-intrusively passed through the constituents present in the fluid mixture passing through the pipe. The permittivity changes in the constituents present in the fluid mixture passing through the pipe causes shifts in the resonant frequencies, which are measured using a receiver antenna or a loop antenna to recognize the changes in the permittivity of the measured phases and differentiate between the volume fractions of the constituents present in the fluid mixture. The present system, apparatus and method can be used for determining the volume fractions of different types of constituents, such as, but not limited to, water, air and oil, present in the fluid mixture obtained from oil drilling

operations. Further the present system, apparatus and method can also be employed for non-intrusive real-time continuous measurement of constituents, such as, but not limited to, water, air and oil, present in the fluid mixture obtained from oil drilling operations, while it is passing through the pipe.

Referring to the figure 1 is a schematic diagram showing a multiphase flow metering system (100) for measuring the relative volumetric proportions and temperature of a number of constituents present in a fluid mixture passing through a pipe (118), according to a preferred embodiment of the present invention. The multiphase flow metering system (100) for measuring the relative volumetric proportions the constituents in the fluid mixture passing through the pipe (118) includes an apparatus (102) non-intrusively placed around the pipe (118) carrying the fluid mixture. The apparatus (102) includes a cylindrical cavity structure (104) longitudinally and coaxially placed around the pipe (118) carrying the fluid mixture. The cylindrical cavity structure (104) has a pair of open ends and a diameter larger than the diameter of the pipe (118) and is longitudinally placed around the pipe (118) carrying the fluid mixture. In a preferred embodiment, the cylindrical cavity structure (104) includes a first microwave sensor system (108) having a first loop antenna (114) placed on an inner wall of the cylindrical cavity structure (104) and a first electronic means or platform not shown capable of generating electromagnetic signals at a first predetermined frequency. The apparatus (102) further includes a rectangular cavity structure (106) vertically placed across the pipe (118). In a preferred embodiment, the rectangular cavity structure (106) includes a second microwave sensor system (110) having a second loop antenna (116) placed on an inner wall of the rectangular cavity structure (106) and a second electronic means or platform not shown capable of generating electromagnetic signals at a second predetermined frequency. Each of the first loop antenna (114) connected to the first electronic means and the second loop antenna (116) connected to the second electronic means are configured to operate in a two port config-

uration, i.e. capable of transmission and reception of signals, to transmit and receive the microwave signs within the apparatus (102).

The microwave signals generated by the first electronic means and transmitted by the first loop antenna (114), at the first predetermined frequency within the cylindrical cavity structure (104), passes through the constituents of the fluid mixture flowing through the pipe (118) and gets a shift in frequency caused by the difference in permittivity of the constituents present in the fluid mixture. Similarly, the microwave signals generated by the second electronic means and transmitted by the second loop antenna (116), at the second predetermined frequency within the rectangular cavity structure (106), passes through the constituents of the fluid mixture flowing through the pipe (118) and gets a shift in frequency caused by the difference in permittivity of the constituents present in the fluid mixture. The attenuated and reflected microwave signals with shifts in frequency from its first predetermined frequency and the second predetermined frequency are detected by the first loop antenna (114) and the second loop antenna (116), both operating in two-port configuration, respectively. The present multiphase flow metering system (100) further includes a computer system (120) running a frequency analysis and multiphase flow metering application analyzes the outputs from the first microwave sensor system (108) and the second microwave sensor system (110). The frequency analysis and multiphase flow metering application compares the first predetermined frequency of the microwave signals generated by the first loop antenna (114) and transmitted inside cylindrical cavity structure (104) and the shift in the frequency of the reflected or received microwave signals and the second predetermined frequency of the microwave signals generated by the second loop antenna (116) and transmitted inside the rectangular cavity structure (106) and the shift in the frequency of the reflected or received microwave signals to identify the relative volumetric proportion of the constituents in the fluid mixture passing through a pipe (118). The present multiphase flow metering system (100) measures and analyzes

the shift in frequency of the microwave signals passing through the constituents present in the fluid mixture to determine the relative volumetric proportions and a temperature of the constituents in the fluid mixture in real-time.

Referring to the figure 2 is a schematic diagram showing the apparatus (102) utilized for determining the relative volumetric proportions and temperature of the constituents present in the fluid mixture passing through a pipe (118), according to a preferred embodiment of the present invention. The apparatus (102) includes the cylindrical cavity structure (104) having the pair of open ends configured to be longitudinally and coaxially placed around the pipe (118), which is having a smaller diameter, carrying the fluid mixture. The coaxially placed cylindrical cavity structure (104) guides the microwave signals generated by the first microwave sensor system (108) at the first predetermined frequency in a longitudinal direction along the axis of the pipe (118). The cylindrical cavity structure (104) includes the first microwave sensor system (108) placed, non-intrusively, within the inner walls of the cylindrical cavity structure (104) for generating and transmitting the microwave signals at the first predetermined frequency within the cylindrical cavity structure (104) through the constituents present in the fluid mixture passing through the pipe (118). The first microwave sensor system (108) also acts as the receiver for receiving the reflected microwave signals at a first altered frequency. The apparatus (102) also includes the rectangular cavity structure (106) placed vertically across the pipe (118) carrying the fluid mixture. The rectangular cavity structure (106) guides the microwave signals generated by the second microwave sensor system (110) at the second predetermined frequency in a transverse direction across the pipe (118). The rectangular cavity structure (106) includes the second microwave sensor system (110), which is non-intrusively placed, within the inner walls of the cylindrical cavity structure (104) for generating and transmitting the microwave signals at the second predetermined frequency within the rectangular cavity structure (106) through the constituents present in the fluid mixture passing through the

pipe (118). The second microwave sensor system (110) also acts as a receiver for receiving the reflected microwave signals at a second altered frequency. The shift in frequency of the microwave signals from the first predetermined frequency to the first altered frequency and from the second predetermined frequency to the second altered frequency are analyzed using the frequency analysis and multiphase flow metering application running on the computer system (120), which is in communication with the first microwave sensor system (108) and the second microwave sensor system (110), to determine the relative volumetric proportions and the temperature of the constituents in the fluid mixture.

In a preferred embodiment of the present invention, the first microwave sensor system (108) includes the first electronic means or an electronic board capable of generating the microwave signals at the first predetermined frequency, which is selected between a frequency range of 5-5.7 GHz, and the first loop antenna (114) connected to the first electronic means capable of transmitting the microwave signals at the first predetermined frequency, through the constituents in the fluid mixture, both placed on the inner walls of the cylindrical cavity structure (104). The first loop antenna (114) is configured to operate in a two-port configuration and is capable of transmitting the microwave signals at the first predetermined frequency and receiving the reflected microwave signals, which are passed through the constituents in the fluid mixture, at the first altered frequency. In some other instances, the first electronic means or an electronic board of the first microwave sensor system (108) is placed outside the cylindrical cavity structure (104). However, in all these instances, the first microwave sensor system (108) involving the first electronic means and the first loop antenna (114) is non-intrusively or non-invasively placed outside the pipe (118) carrying the fluid mixture.

Similarly in a preferred embodiment of the present invention, the second microwave sensor system (110) includes the second electronic means or an electronic board capable of generating the microwave signals at the second predetermined frequency, which is

selected between a frequency range of 1-1.25GHz, and the second loop antenna (116) connected to the second electronic means capable of transmitting the microwave signals at the second predetermined frequency through the constituents in the fluid mixture, both placed on the inner walls of the rectangular cavity structure (106). The second loop antenna (116) is also configured to operate in a two-port configuration and is capable of transmitting the microwave signals at the second predetermined frequency and receiving the reflected microwave signals, which are passed through the constituents in the fluid mixture, at the second altered frequency. In some other instances, the second electronic means or an electronic board of the second microwave sensor system (110) is placed outside the rectangular cavity structure (106). However, in all these instances, the second microwave sensor system (110) involving the first electronic means and the second loop antenna (116) is non-intrusively or non-invasively placed outside the pipe (118) carrying the fluid mixture. In some other embodiment, the first microwave sensor system (108) and the second microwave sensor system (110) shares a common electronic means or electronic board for generating microwave signals in the first predetermined frequency and the second predetermined frequency.

In a preferred embodiment of the present invention, the first loop antenna (114) is placed on the inner wall of the cylindrical cavity structure (104) to create resonance at a resonant frequency, within 5-5.7 GHz range, for monitoring changes in permittivity of each of the constituents in the fluid mixture. Similarly, the second loop antenna (116) is placed on the inner wall of the rectangular cavity structure (106) to create resonance at a resonant frequency, within 1-1.25GHz ranges, for monitoring slight variations in permittivity and a change in temperature of each of the constituents in the fluid mixture. The present multiphase flow metering system (100) and the apparatus (102) enables real-time continuous measurements of the relative volumetric proportions of the constituents in the fluid mixture passing through the pipe (118). In some instances, the present multiphase

flow metering system (100) and the apparatus (102) also enables real-time continuous measurements of the temperature of one or more constituents in the fluid mixture passing through the pipe (118). The present multiphase flow metering system (100) and apparatus (102) has a wide range of applications, including in oil drilling, where the apparatus (102) can be employed to determine the relative volumetric proportions including water-air fraction, water-oil fraction and oil-air fraction in the oil-water mixture flowing through the oil extracting pipe (118). Several other modifications to the present multiphase flow metering system (100) and the apparatus (102) can be made without departing from the scope of the claims of the present disclosure. However all such modifications are covered under the present disclosure for the multiphase flow metering system (100) and the apparatus (102).

Referring to the figure 3 shows a flowchart of a method of measuring the relative volumetric proportion of the constituents in the fluid mixture passing through the pipe (118), according to an embodiment of the present invention. The present method of measuring the relative volumetric proportion of the constituents in the fluid mixture passing through the pipe (118) includes the steps of providing the apparatus (102) having the cylindrical cavity structure (104) with the first microwave sensor system (108) non-intrusively placed around the pipe (118) and the rectangular cavity structure (106) with the second microwave sensor system (110) non-intrusively placed across the pipe (118), as in block 200. Once the apparatus (102) is properly placed, non-intrusively around the pipe (118) carrying the fluid mixture, the users can manually or remotely instruct the first microwave sensor system (108) to transmit the microwave signals at the first predetermined frequency, which is anywhere from 5-5.7 GHz frequency range in a longitudinal direction through the fluid mixture, as in block 202. In a preferred embodiment of the present invention, the first loop antenna (114) associated with the first microwave sensor system (108) creates resonance inside the cylindrical cavity structure (104) at a first resonant fre-

quency, which is a value within 5-5.7 GHz. Similarly, the second microwave sensor system (110) transmit the microwave signals at the second predetermined frequency selected from 1-1.25GHz frequency range across the pipe (118) carrying the fluid mixture, as in block 204. In a preferred embodiment of the present invention, the second loop antenna (116) associated with the second microwave sensor system (110) creates resonance at a second resonant frequency within 1-1.25GHz. In a preferred embodiment of the present invention, both the first microwave sensor system (108) comprising the first loop antenna (114) and the second microwave sensor system (110) comprising the second loop antenna (116) operates in a two port configuration, capable of transmitting the microwave signals through the constituents in the fluid mixture and receiving the reflected signals. Now as in block 206, the reflected microwave signals at the first altered frequency are received using the first loop antenna (114) of the first microwave sensor system (108). And the reflected microwave signals at the second altered frequency are received using the second loop antenna (116) of the second microwave sensor system (110), as in block 208. Now as in block 210, the shift in frequency in the first altered frequency and the second altered frequency from the first resonant frequency and the second resonant frequency, respectively, is automatically calculated in real-time using the frequency analysis and multiphase flow metering application running on the computer system (120), such as a central server in communication with the first and second microwave sensor systems (108, 110). Then the real-time continuous measurements of the relative volumetric proportions of the constituents and the temperature of the constituents in the fluid mixture, based on the shift in frequency, is provided to the users via a user interface of the frequency analysis and multiphase flow metering application running on the computer system (120), as in block 212,

The following sections discuss the field analysis process and the relative volumetric concentrations of the constituents in a fluid mixture obtained by analyzing of the mi-

crowave signals using the present multiphase flow metering system (100), according to one or more embodiment of the present invention.

The principle of real-time continuous monitoring the relative volumetric concentrations of the constituents in the fluid mixture passing through a pipe (118), such as the one's used in hydrocarbon excavation, using the microwave sensors, is based on the interaction of electromagnetic, EM, waves. When a fluid mixture sample is exposed to the EM irradiation, it alters the velocity of the signal, attenuates, or reflects it. If the electromagnetic, EM, waves is directed into a hollow structure with conducting walls i.e., a cavity, it will resonate when it is excited at an appropriate EM frequency. In order to generate the electromagnetic waves at resonant frequency within the cavity, such as the cylindrical and rectangular cavity structures (104, 106) used in the present system (100), for example, a small antenna placed inside it. In one or more embodiment of the present invention, as discussed above, the antennas placed inside the cylindrical and rectangular cavity structures (104, 106) are the first loop antenna (114) and the second loop antenna (116), respectively, each operating in a two port configuration capable of transmitting and receiving the electromagnetic signals, i.e. the electromagnetic signals in the microwave region. The resonant modes occur inside the cylindrical and rectangular cavity structures (104, 106) or any type of cavity when the electric or magnetic components of the EM signal form standing wave pattern, which is dependent on the dimensions of the cavity and the dielectric properties of the constituents of the test sample, i.e. the fluid mixture. The resonant frequency for TE_{nml} mode in a rectangular waveguide, which is created inside the rectangular cavity structure (106), can be calculated using Equation:

$$f_{nml} = \frac{c}{2\pi\sqrt{\mu_r\epsilon_r}} \left[\left(\frac{p_{nm}}{b} \right)^2 + \left(\frac{l\pi}{d} \right)^2 \right]^{\frac{1}{2}} \quad (1)$$

where ϵ_r is the relative permittivity of the material, μ_r is the relative permeability of

the material, c is the velocity of light, d is the depth of the cavity, P_{mn} is the m^{th} root of the Bessel function of the n^{th} order and b is the radius of the cavity.

$$f_{mnl} = \frac{c}{2\pi\sqrt{\mu_r\epsilon_r}} \sqrt{\left(\frac{m\lambda}{a}\right)^2 + \left(\frac{n\lambda}{b}\right)^2 + \left(\frac{l\pi}{d}\right)^2} \quad (2)$$

where c is the velocity of light, μ_r is the relative permeability, ϵ_r is the relative permittivity, p_{nm} is the Bessel function of the n th order for the TE or TM modes of a rectangular cavity, a is the width of the cavity, b is the height of the cavity, d is the depth of the cavity.

The main principle of microwave analysis and monitoring, according to present invention, is based on the material interaction, i.e. the interaction of the constituents of the fluid mixture with microwave signals. According to one or more embodiment of the present invention, the broadband microwave analysis of the constituents of the fluid mixture provides unique signal spectrums in the form of reflection coefficient (S_{11}) and transmission coefficient (S_{21}) based on the parameters such as conductivity and permittivity of each of the constituents in the fluid mixture. Conductivity is defined as the material's ability to conduct electric current. Permittivity is a complex value that measures the effect of a dielectric medium, such as the constituents in the fluid mixture, on the applied electric field. This is determined by the constituents' ability to polarize in response to the applied field and how the total electric field is reduced inside the material inside the cavity. The above properties accounts for two main parameters, such as the dielectric constant and dielectric loss of the constituents. The dielectric constant accounts for the energy stored inside the constituents on the application of EM waves whereas the dielectric loss represents any losses of energy when polarizing the constituents.

Any change in the constituents' concentration, percentage, type, etc. changes its permittivity that causes the change in the microwave response when the constituents interact

with it. The present apparatus (102) and the multiphase flow metering system (100) can be used to measure the response over the range of discrete frequencies the material can be characterized. Water, for example, is a polar molecule due to the charge separation that exists between the hydrogen and oxygen atoms. As a result, it has relatively high permittivity ($\epsilon_r = 81$, at 15°C). This can be detected using the cylindrical cavity structure (104) operating at 5-5.7 GHz frequency. Hence, a small change in water fraction may result in comparatively large frequency shift. On the other hand, gases have low permittivity values approximately equal to ($\epsilon_r = 1$). Non-polar materials such as oil have low permittivity value ($\epsilon_r = 2.2$ to 2.5). This tiny change in the permittivity is hardly detected by the first microwave sensor system (108) installed in the cylindrical cavity structure (104). The second microwave sensor system (110), of the present multiphase flow metering system (100), with the second loop antenna (116) placed on the inner wall of the rectangular cavity structure (106) picks up these tiny shifts in the permittivity when the temperature change or low permittivity material is used.

The following description shows the actual experimental data obtained by using the present multiphase flow metering system (100), according to an embodiment of the present invention.

The measurements of the change in the volume fraction of two-phase systems, using the present multiphase flow metering system (100), is first conducted over the full range of spectrum between 9 kHz and 6 GHz. However, it is then found that the frequency below 5 GHz has a high noise and do not correspond to the changes in percentage of water. The results of the frequency response are also not consistent with change in the fraction percentage. The frequencies above 5.7 GHz are eliminated because of the ambiguous microwave response as well as to avoid the multi modes and complexities in the data analysis in the later stage. The following measurements were taken between 5-5.7 GHz with the cylindrical cavity structure (104) operating in TE_{124} mode. The experimentation

is conducted by measuring the volume fraction of water required to fill the PVC pipe (118), which is preset to value equal to 740 ml. The volume is then divided by 5 to get the amount of volume fraction increase each time in the pipe (118), which equaled to 148 ml. The measurements are first taken with the empty pipe (118), i.e. filled with 100% of air. Afterwards, each 148ml of water is added into the pipe (118) representing 20% increase in the water fraction and in proportion 20% decrease in the air fraction. The LabVIEW program designed to display the microwave spectra is used to capture and record the data in real-time. The percentage of the volume of water is increased from 0-100% in the pipeline (118). Likewise, similar procedure was repeated with oil-water volume fractions with oil starting at 0% and water at 100%, i.e. 740 ml. The percentage of water is decreased and oil increased by 20% and measurements taken for each of the percentage increase till the pipe (118) is filled with 100% oil. Same measurement technique is applied using the rectangular cavity structure (106) operating in TE₁₁₃ mode. The measurements are taken between 1-1.25 GHz.

The sensors are designed such that the cavity diameter is larger than the pipeline (118) and open at both ends. This design allowed the pipeline (118) to appear continuous as shown in the figure 2. This non-intrusive design allows the first loop antenna (114) and the second loop antenna (116), which were used to excite the resonant modes, to be separate from the fluid and the pipeline (118). This also allows both the pipeline (118) to be clean with the cavity and the first loop antenna (114) and the second loop antenna (116) in place and protected from the flowing fluid within the pipe (118).

After setting up the system (100) as discussed above, a temperature independent study of the cylindrical cavity structure (104) is conducted. In the temperature dependent study of water in the cylindrical cavity structure (104), the pipe (118) is filled with 100% of water at 83°C and the microwave signal response is captured and recorded as discussed above. The variation of resonant frequency with drop in temperature is recorded.

The interval of the data recording is set manually corresponding to the temperature drop, approximately every 10°C. The data is digitally controlled in an actual measuring environment and recorded to enable real-time measurements.

Referring to the figure 4 shows the comparison of water-air fractions as discussed in the previous paragraphs. The highlighted section in the figure demonstrate a shift in the frequency and change in the amplitude of samples when the ratio of the volume fraction of air decreases from 100-0% and water increase from 0-100%. Analysis of the figure 4 shows that:

- The frequency of the microwave response curve decreases and shifts to the left from 5.496 GHz to 5.470 GHz as the increase in the water fraction takes place in five steps of 20% each. It equates to a total shift of approximately 25.5 MHz. Keeping into consideration the sensitivity of the technique the shift is significant.
- In addition to the frequency shift, a significant change in the amplitude is also observed as in the figure 4. The amplitude decreases as the percentage of the water increase and air decreases. The overall decrease in the amplitude from 100% air to 100% water is approximately -11.2789 dB.

The changes between each of the 20% fraction change of both water-air and water-oil flows are also analyzed. The frequency shift and amplitude change profile was plotted for each of the air-water and oil-water fractions and is shown in the figure 5. The results of the frequency plot in the figure 5 shows that there is a measurable frequency shift for each of the fraction percent change. The frequency decreases when the water fraction increases to 100% in both water-air and water-oil two phase flows. The figure 5 shows the comparison between the experimental and simulation results. The frequency corresponding to the maximum amplitude of each percentage of water is obtained and compared

between experimental and simulation results. Both the results show drop in frequency when the percentage of water increases.

The third set of analysis is conducted on water filled pipe (118) to monitor if the change in temperature affects the microwave response curves. This is to monitor the temperature dependence of microwave measurement technique. The figure 6 shows the frequency and amplitude of 100% water in the pipe (118) with different temperatures. It shows that no frequency shift is observed up to the temperature of 280C. The temperature of the water is varied between 83°C and 28°C and this has been seen not affecting the accuracy, despite the permittivity of water changing with the temperature. This is assumed to be due to the different overlapping modes negating the affect, as in adjacent frequency ranges if it is found that the affect is obvious.

The detection of oil-gas is then tested using the second microwave sensor system (110) in the rectangular cavity structure (106). The changes in peak frequency each of the 20% fraction increment of oil is plotted, as shown in the figure 7. The experiment is repeated three times and the average value is calculated. The results of the frequency plot in the figure 7 shows that there is a measureable frequency shift for each of the fraction percent change. The frequency decreases when the oil fraction increases to 100% in this case, it can be represented using a linear function.

During the experiment of oil-gas liquid fraction, little changes in the permeability can be detected using the rectangular cavity structure (106). An experiment was carried out to detect the temperature changes using 100% water fully filled pipe (118). The pipe (118) is filled using hot boiling water and it is left to cold down while the data was taken. A temperature probe was inserted inside the pipe away from the cavity to measure the water temperature. The experiment is repeated for three times and the average temperature is calculated, the results are plotted shown in figure 8. The results show that there is a measureable frequency shift for each 5°C, it can be represent as a linear function. The

frequency decreases when the water cool from 85°C to 40°C.

In the above experiments and comparisons, the electromagnetic waves ranging from 5GHz up to 5.7GHz for the first microwave sensor system (108) and 1GHz to 1.25GHz for the second microwave sensor system (110) have been used to analyze the two phase fluid fraction in a pipeline (118). Labview software, which functions as the frequency analysis and multiphase flow metering application, is utilized to capture and process the data, and display the results in real time. The first microwave sensor system (108) of the cylindrical cavity structure (104) is used to detect the water level independent to the temperature change. The second microwave sensor system (110) of the rectangular cavity structure (106) picks up the tiny shifts in the permittivity when the temperature change or low permittivity material is used. Hence the present multiphase flow metering system (100) utilizing the apparatus (102) involving the cylindrical cavity structure (104) and the rectangular cavity structure (106) is able to detect water/air fraction, water/oil fraction, oil/air fraction and water temperature.

Further, it should be noted that the steps described in the method of use can be carried out in many different orders according to user preference. Upon reading this specification, it should be appreciated that, under appropriate circumstances, considering such issues as design preference, user preferences, marketing preferences, cost, structural requirements, available materials, technological advances, etc., other methods of use arrangements such as, for example, different orders within above-mentioned list, elimination or addition of certain steps, including or excluding certain maintenance steps, etc., may be sufficient.

The foregoing description of the preferred embodiment of the present invention has been presented for the purpose of illustration and description. It is not intended to be exhaustive or to limit the invention to the precise form disclosed. Many modifications and variations are possible in light of the above teachings. It is intended that the scope of the present invention not be limited by this detailed description, but by the claims and the

equivalents to the claims appended hereto.

WE CLAIM

1. A multiphase flow metering system (100) for measuring at least one relative volumetric proportion of a plurality of constituents in a fluid mixture passing through a pipe (118) comprising: an apparatus (102) non-intrusively placed around the pipe (118) carrying the fluid mixture, wherein the apparatus (102) includes: a cylindrical cavity structure (104) having a first microwave sensor system (108); a rectangular cavity structure (106) having a second microwave sensor system (110); and a computer system (120) running a frequency analysis and multiphase flow metering application for analyzing at least once output from the first microwave sensor system (108) and the second microwave sensor system (110); characterized in that at least one shift in frequency of a plurality of microwave signals passed through the plurality of constituents are analyzed to determine the relative volumetric proportions and at least one temperature of the plurality of constituents in the fluid mixture.
2. The multiphase flow metering system (100) of claim 1, wherein the cylindrical cavity structure (104) is longitudinally and coaxially placed around the pipe (118) and the rectangular cavity structure (106) is vertically placed across the pipe (118).
3. The multiphase flow metering system (100) of claim 1, wherein the first microwave sensor system (108) includes a first loop antenna (114) placed on an inner wall of the cylindrical cavity structure (104), the first loop antenna (114) being capable of operating in a two port configuration for: transmitting a plurality of microwave signals through the fluid mixture at a first predetermined frequency selected from 5-5.7 GHz frequency range; and receiving a plurality of reflected microwave signals at a first altered frequency.
4. The multiphase flow metering system (100) of claim 1, wherein the second microwave sensor system (110) includes a second loop antenna (116) placed on an

inner wall of the rectangular cavity structure (106), the second loop antenna (116) being capable of operating in a two port configuration for: transmitting a plurality of microwave signals through the fluid mixture at a second predetermined frequency selected from 1-1.25 GHz frequency range; and, receiving a plurality of reflected microwave signals at a first altered frequency.

5. The multiphase flow metering system (100) of claim 3, wherein the first loop antenna placed on the inner wall of the cylindrical cavity structure (104) creates resonance at a resonant frequency within the first predetermined frequency of 5-5.7 GHz for monitoring changes in permittivity of each of the constituents in the fluid mixture.
6. The multiphase flow metering system (100) of claim 4, wherein the second loop antenna placed on an inner wall of the rectangular cavity structure (106) creates resonance at a resonant frequency within the second predetermined frequency of 1-1.25GHz for monitoring slight variations in permittivity with a change in temperature of each of the constituents in the fluid mixture.
7. The multiphase flow metering system (100) of claim 1, wherein the computer system (120) running the frequency analysis and multiphase flow metering application analyzes the shift in the first altered frequency and the second altered frequency to enable real-time continuous measurements of the relative volumetric proportions of the plurality of constituents in the fluid mixture and temperature of the at least one constituent in the fluid mixture passing through the pipe (118).
8. The multiphase flow metering system (100) of claim 1 is capable of determining the relative volumetric proportions including water-air fraction, water-oil fraction and oil-air fraction in the fluid mixture having the constituents in form of water, air

and oil.

9. A method of measuring at least one relative volumetric proportion of a plurality of constituents in a fluid mixture passing through a pipe (118) comprising the steps of: providing an apparatus (102) having a cylindrical cavity structure (104) with a first microwave sensor system (108) non-intrusively placed around the pipe (118) and a rectangular cavity structure (106) with a second microwave sensor system (110) non-intrusively placed across the pipe (118); instructing the first microwave sensor system (108) to transmit a plurality of microwave signals at a first predetermined frequency selected from 5-5.7 GHz frequency range in a longitudinal direction through the fluid mixture, wherein the first microwave sensor system (108) creates resonance at a first resonant frequency within 5-5.7 GHz; instructing the second microwave sensor system (110) to transmit a plurality of microwave signals at a second predetermined frequency selected from 1-1.25GHz frequency range across the pipe (118) carrying the fluid mixture, wherein the second microwave sensor system (110) creates resonance at a second resonant frequency within 1-1.25GHz; receiving a plurality of reflected microwave signals using the first microwave sensor system (108) at a first altered frequency; receiving a plurality of reflected microwave signals using the second microwave sensor system (110) at a second altered frequency; calculating a shift in frequency in the first altered frequency and the second altered frequency from the first resonant frequency and the second resonant frequency, respectively, using a frequency analysis and multiphase flow metering application; and presenting real-time continuous measurements of the relative volumetric proportions of the plurality of constituents in the fluid mixture and temperature of the at least one constituent in the fluid mixture based on the shift in frequency.

10. The method of claim 9, wherein the first microwave sensor system (108) includes a first loop antenna (114) and the second microwave sensor system (110) includes a second loop antenna (116) operating in a two port configuration.

BRIEF DESCRIPTION OF THE DRAWINGS

These and other features, aspects, and advantages of the present invention will become better understood, when the following detailed description is read with reference to the accompanying drawings in which like characters represent like parts throughout the drawings, wherein:

1. Figure 1 is a schematic diagram showing a multiphase flow metering system for measuring the relative volumetric proportions and temperature of a number of constituents present in a fluid mixture passing through a pipe, according to a preferred embodiment of the present invention.
2. Figure 2 is a schematic diagram showing the apparatus utilized for determining the relative volumetric proportions and temperature of the constituents present in the fluid mixture passing through a pipe, according to a preferred embodiment of the present invention.
3. Figure 3 shows a flowchart of a method of measuring the relative volumetric proportion of the constituents in the fluid mixture passing through the pipe, according to an embodiment of the present invention.
4. Figure 4 shows the comparison of air-water fractions in the fluid mixture passing through the pipe, according to an embodiment of the present invention.
5. Figure 5 shows comparison of resonant frequency between experimental and simulation results and shows the frequency shift and amplitude change profile for each of the air-water and oil-water fractions, according to an embodiment of the present invention.
6. Figure 6 is a graph of S_{21} versus frequency at different temperature, which shows the frequency and amplitude of 100% water in the pipe with different temperatures,

according to an embodiment of the present invention.

7. Figure 7 is a graph of frequency shift versus oil fraction increment that shows the changes in peak frequency each of the 20% fraction increment of oil during the detection of gas/oil using the second microwave sensor system in the rectangular cavity structure, according to an embodiment of the present invention.
8. Figure 8 is a graph of frequency shift versus temperature change, in 100% water fully filled pipe, according to an embodiment of the present invention.

ABSTRACT

A MULTIPHASE FLOW METERING SYSTEM FOR MEASURING CONSTITUENTS IN A FLUID MIXTURE

The present invention relates to a multiphase flow metering system (100) and apparatus (102) for measuring the relative volumetric proportions and temperature of constituents in a fluid mixture passing through a pipe (118). The apparatus (102) includes a cylindrical cavity structure (104) having a first microwave sensor system (108) with a first loop antenna (114) is coaxially placed around the pipe (118) and a rectangular cavity structure (106) having a second microwave sensor system (110) with a second loop antenna (116) is vertically placed across the pipe (118). The first and the second microwave sensor system (108, 110), both placed external to the pipe (118), transmits microwave signals at a first and a second predetermined resonant frequencies. A computer system (120) analyzes the shifts in frequencies, based on the permittivity and temperature of the constituents, to identify the relative volumetric proportion of the constituents in real-time.

Most Illustrative Figure: Figure 1

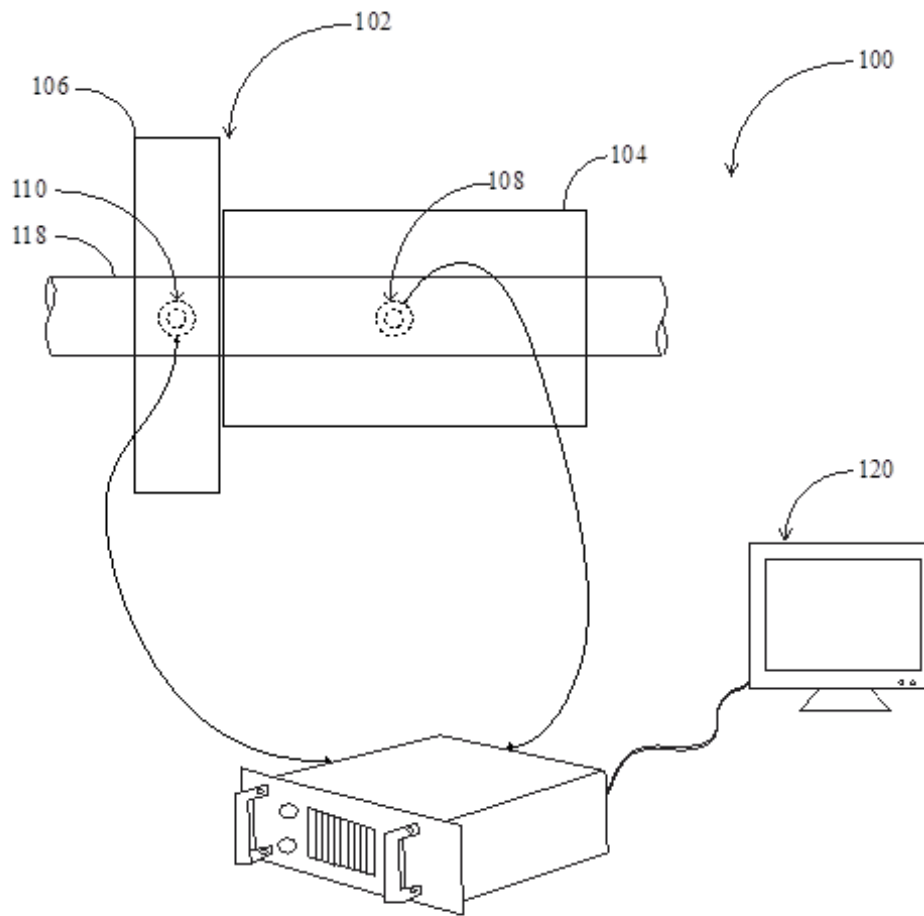

Figure 1. Multiphase flow metering system measurement for the relative volumetric proportions and temperature

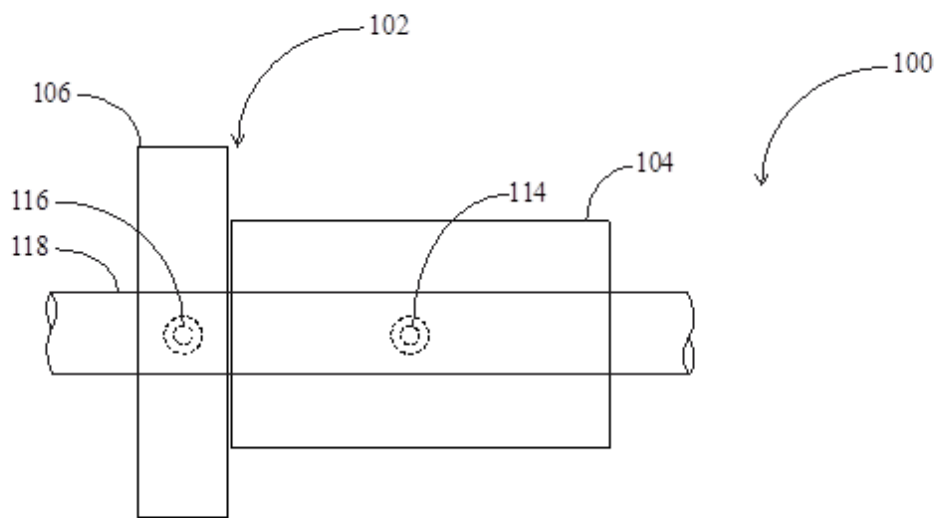

Figure 2. Apparatus utilized for relative volumetric proportions and temperature detection

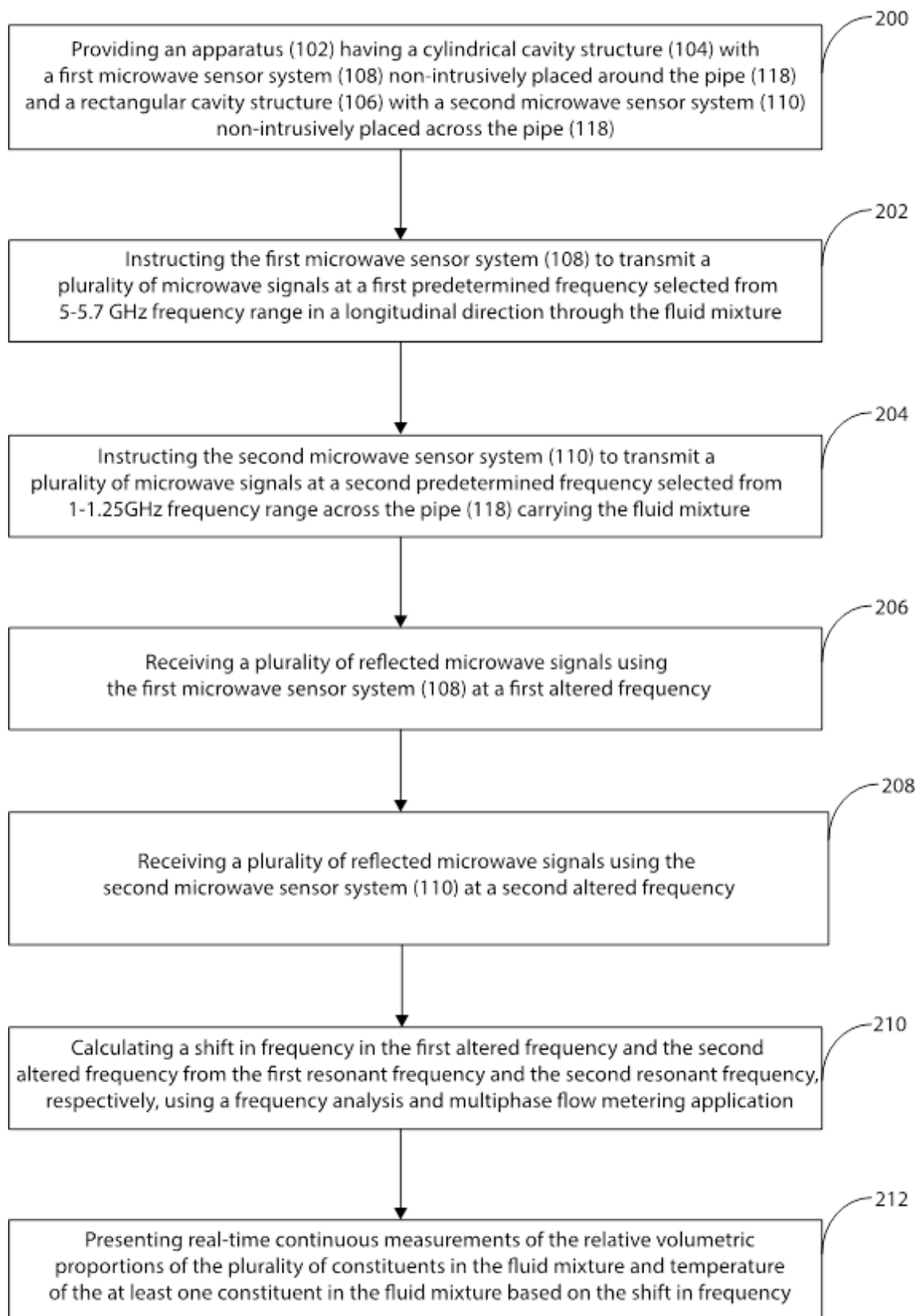

Figure 3. Flowchart of the relative volumetric proportion measurement

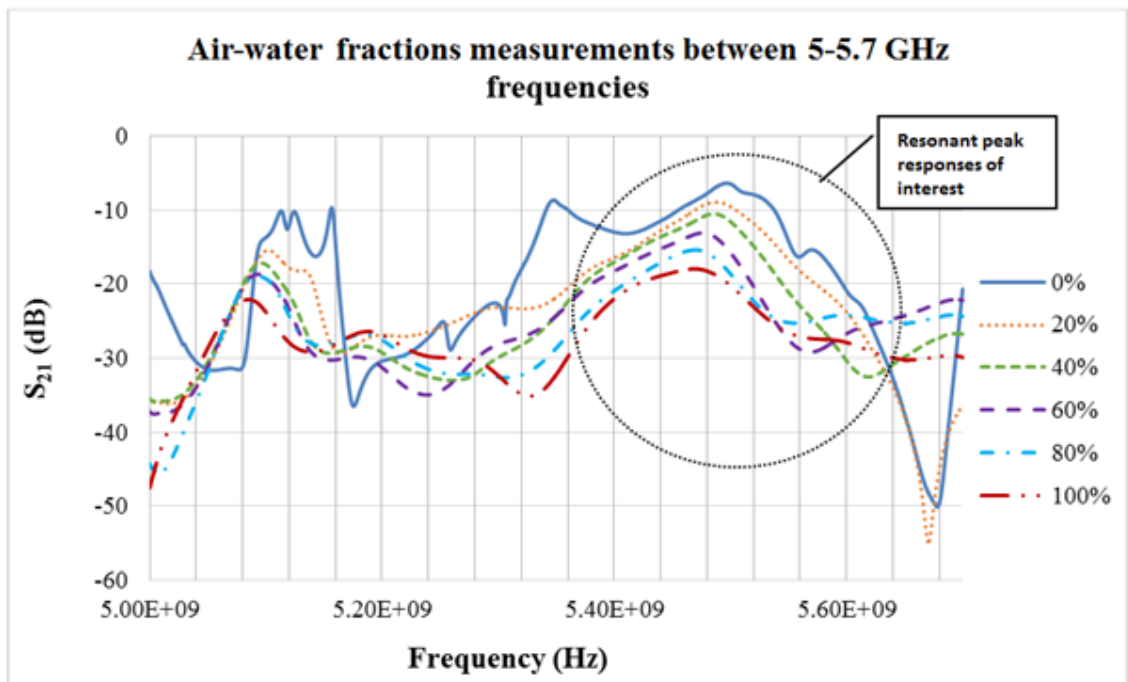

Figure 4. Comparison of water-air fractions in the fluid mixture

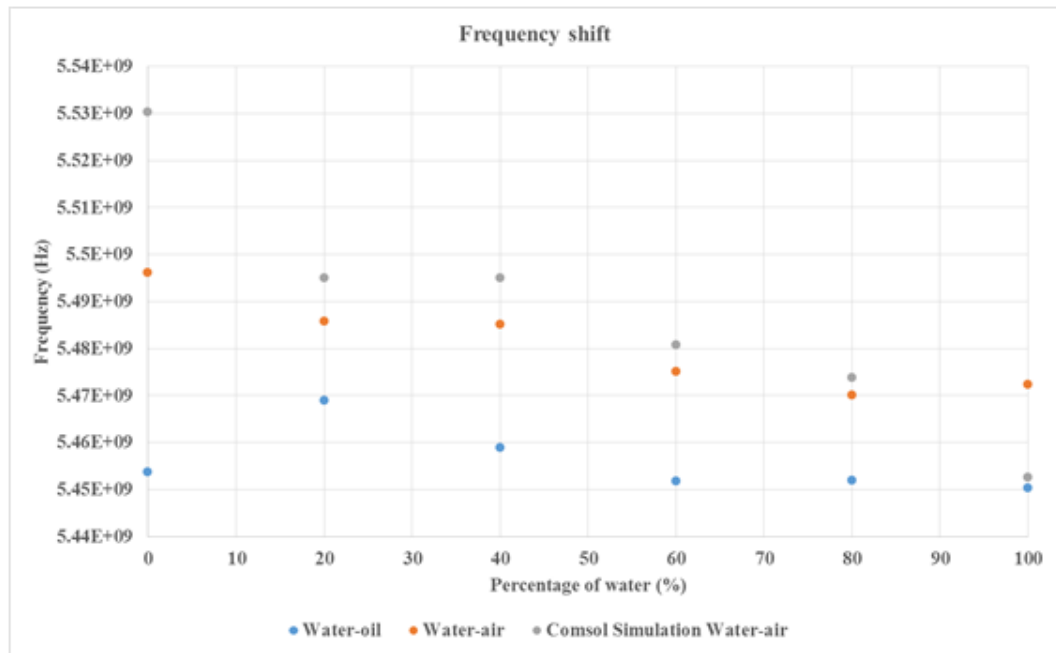

Figure 5. Comparison of resonant frequency between experimental and simulation results

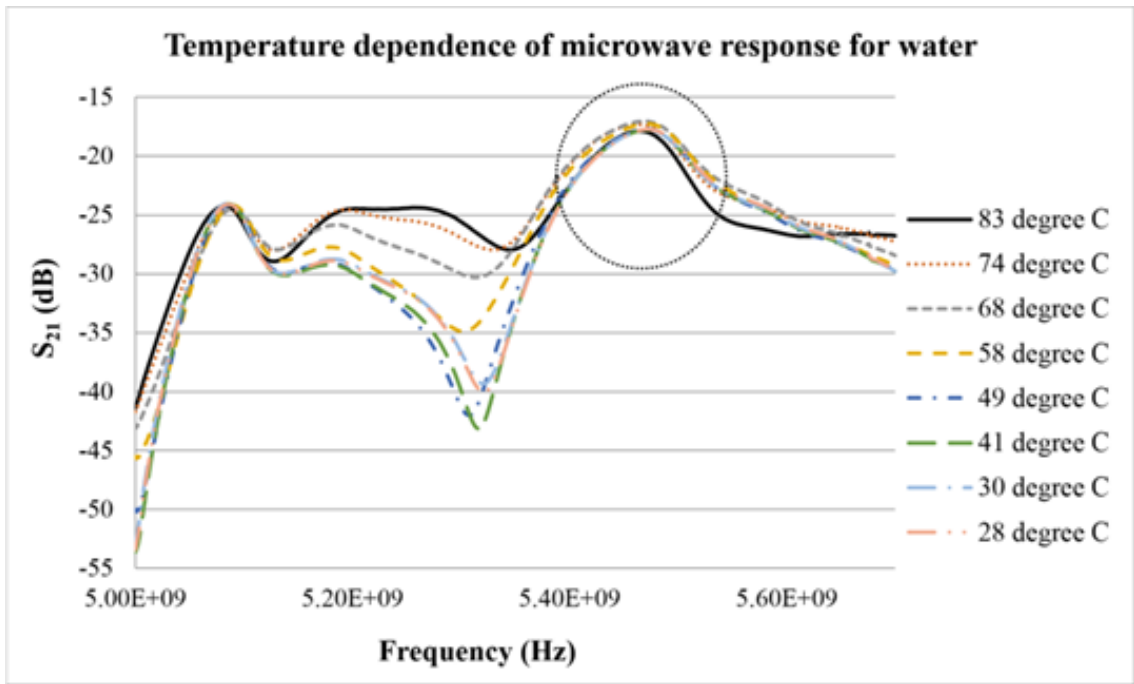

Figure 6. Graph of S_{21} versus frequency at different temperature for 100% water

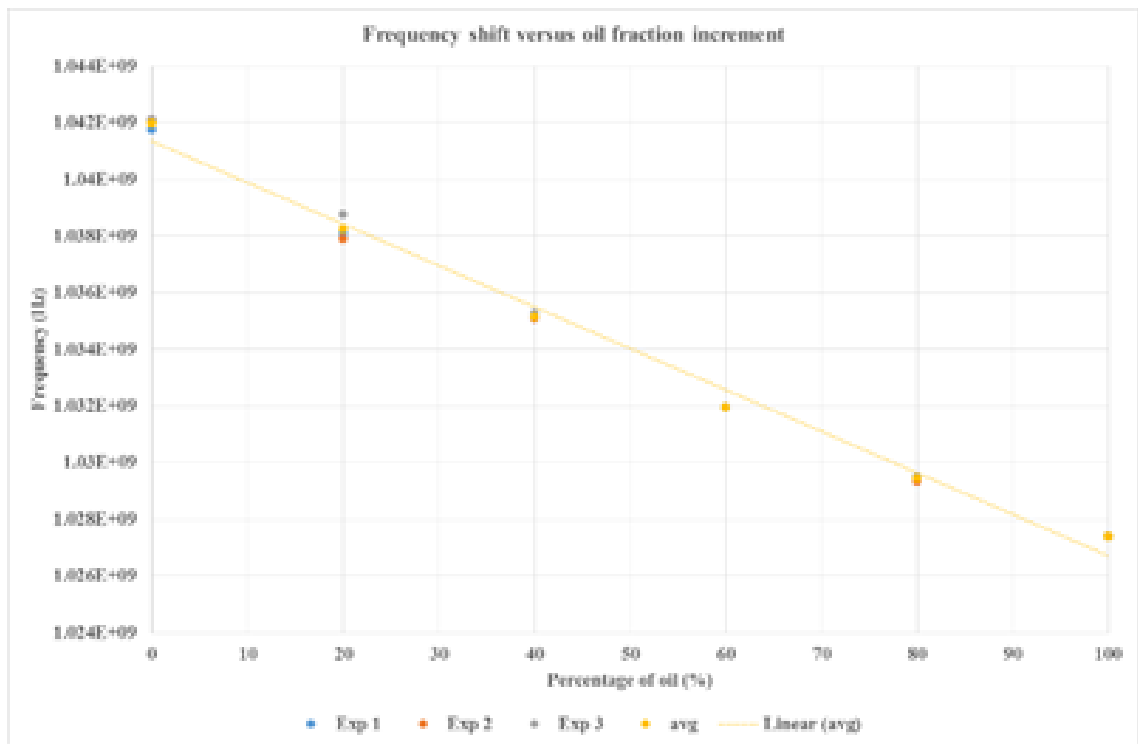

Figure 7. Graph of frequency shift versus oil fraction increment

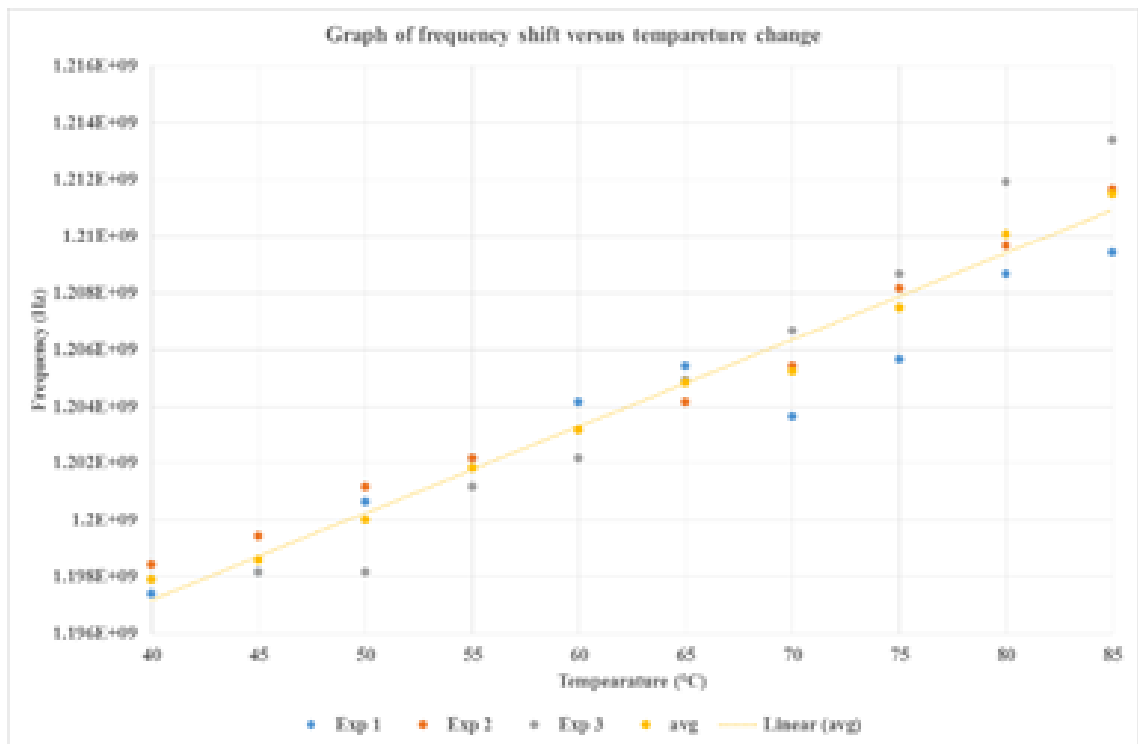

Figure 8. Graph of frequency shift versus temperature change

APPENDIX C DUAL MICROWAVE CAVITY DRAWING

Cylindrical cavity 3D view

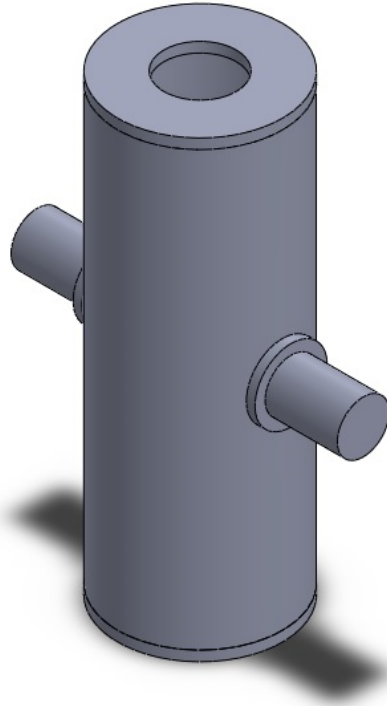

Figure 9. Cylindrical cavity 3D view

Cylindrical cavity front view

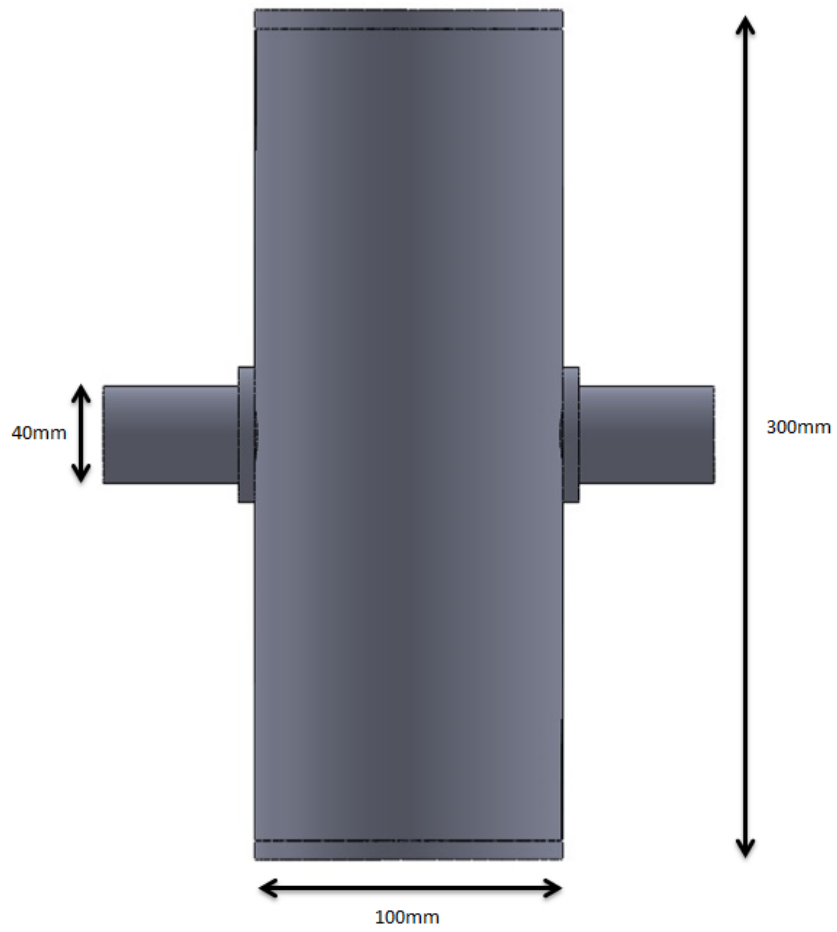

Figure 10. Cylindrical cavity front view

Cylindrical cavity top view

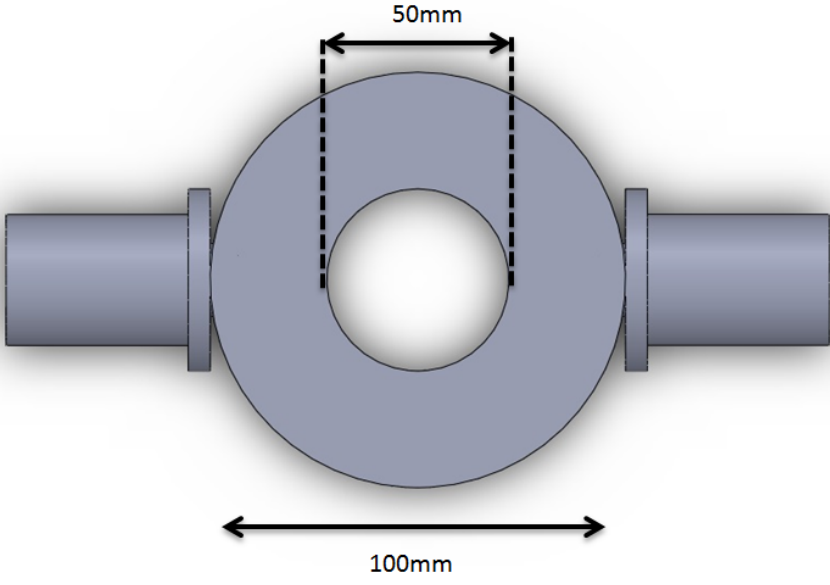

Figure 11. Cylindrical cavity top view

Cylindrical cavity side view

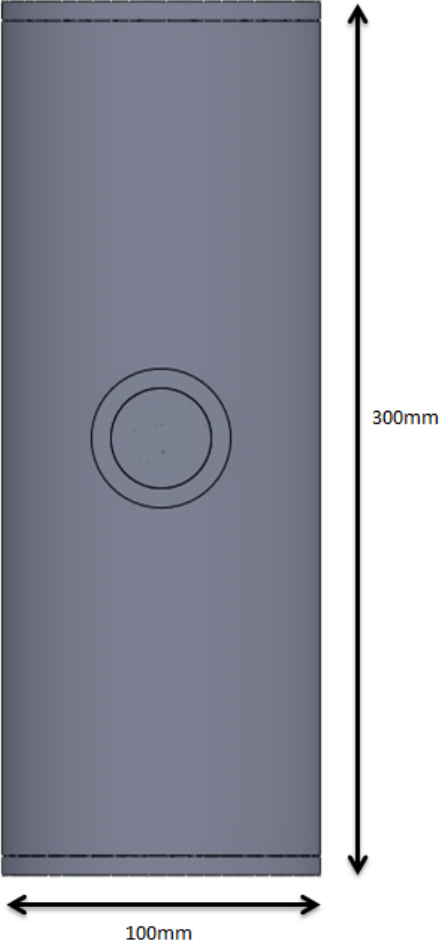

Figure 12. Cylindrical cavity side view

Rectangular cavity 3D view

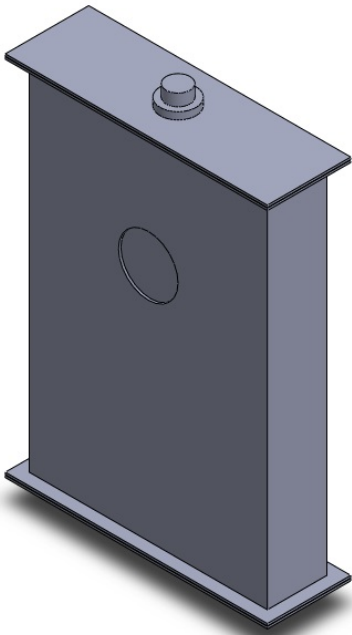

Figure 13. Rectangular cavity 3D view

Rectangular cavity front view

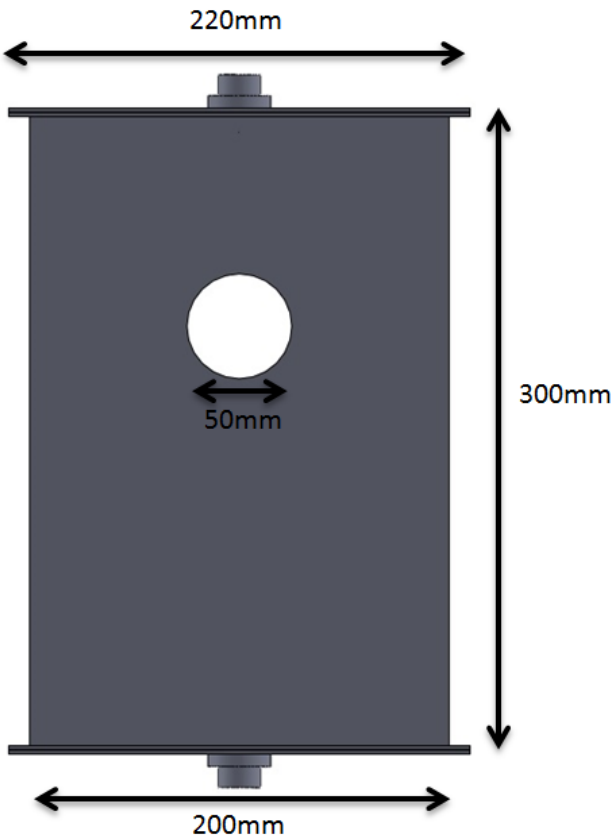

Figure 14. Rectangular cavity front view

Rectangular cavity top view

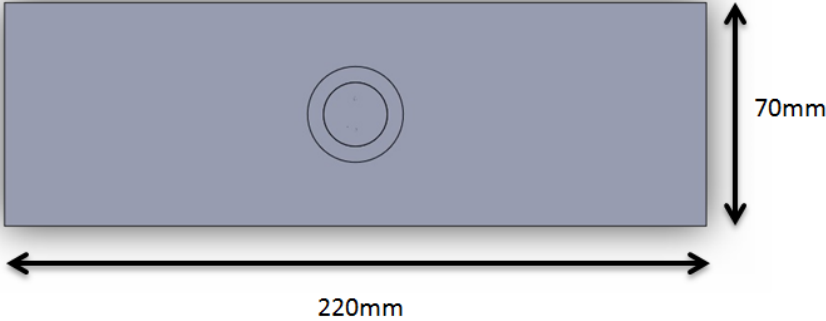

Figure 15. Rectangular cavity top view

Rectangular cavity side view

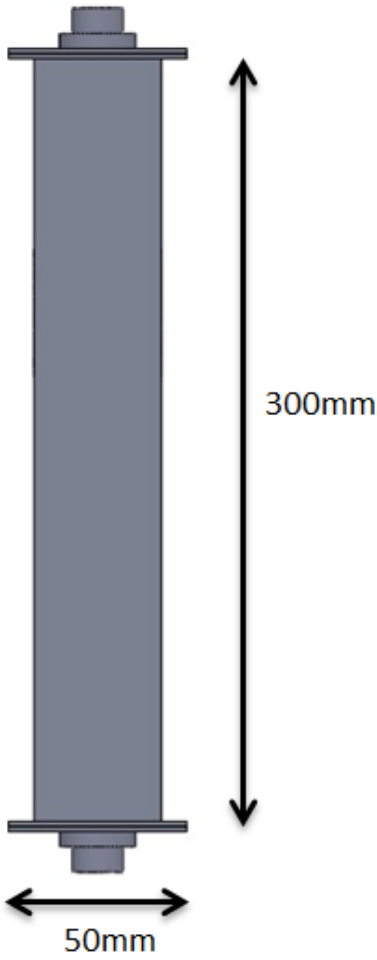

Figure 16. Rectangular cavity side view

Antenna 3D view

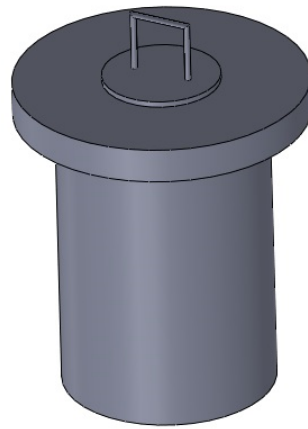

Figure 17. Antenna 3D view

Antenna front view



Figure 18. Antenna front view

Antenna side view

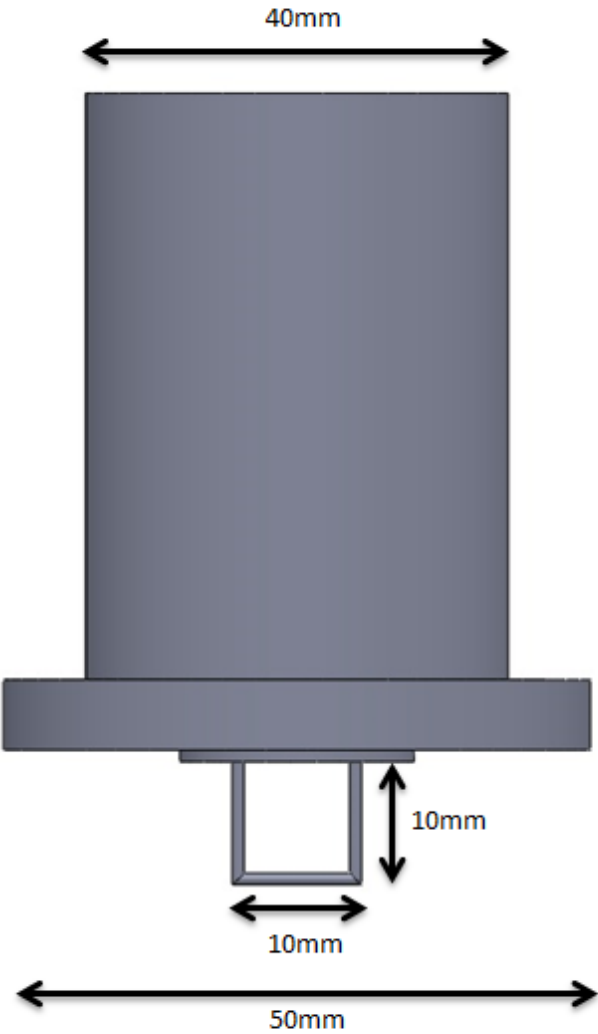

Figure 19. Antenna side view

Dual microwave cavity sensor 3D view

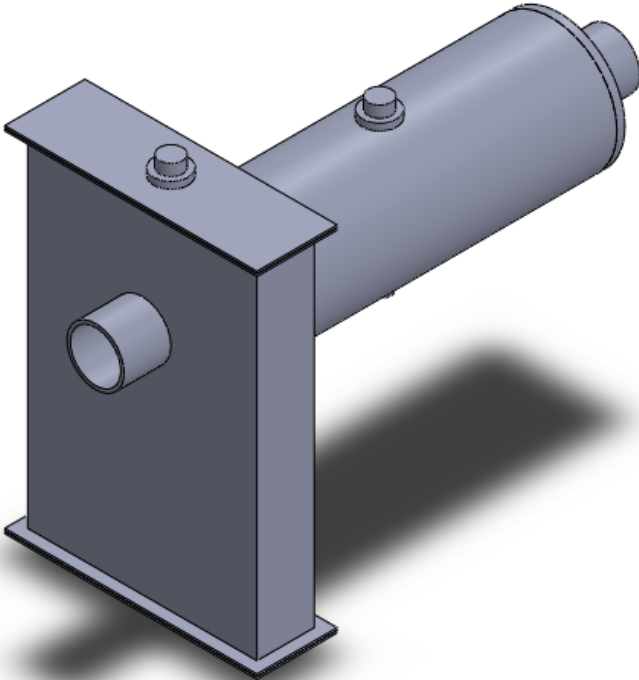

Figure 20. Dual microwave cavity sensor 3D view

Dual microwave cavity sensor front view

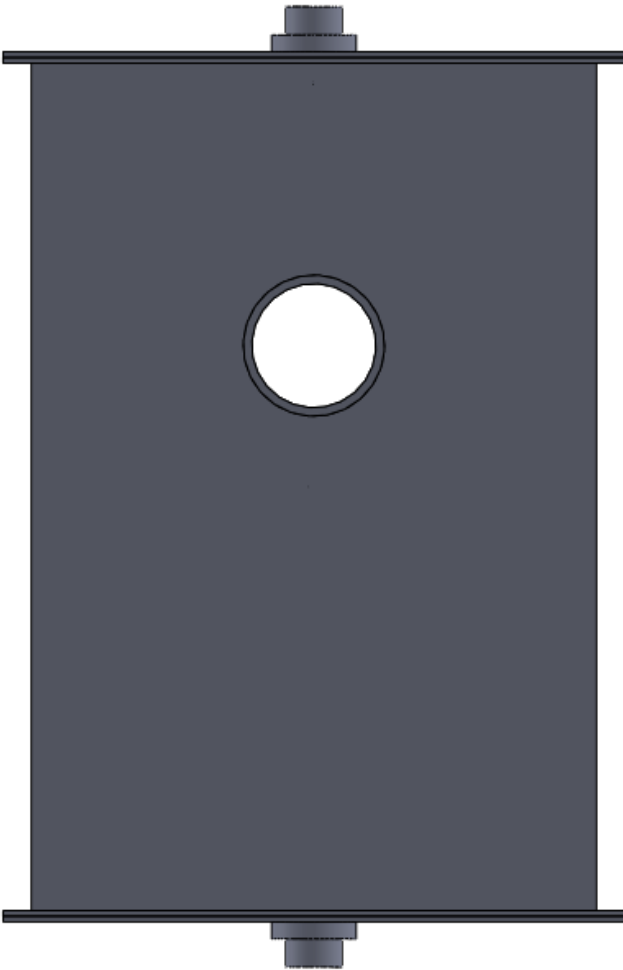

Figure 21. Dual microwave cavity sensor front view

Dual microwave cavity sensor back view

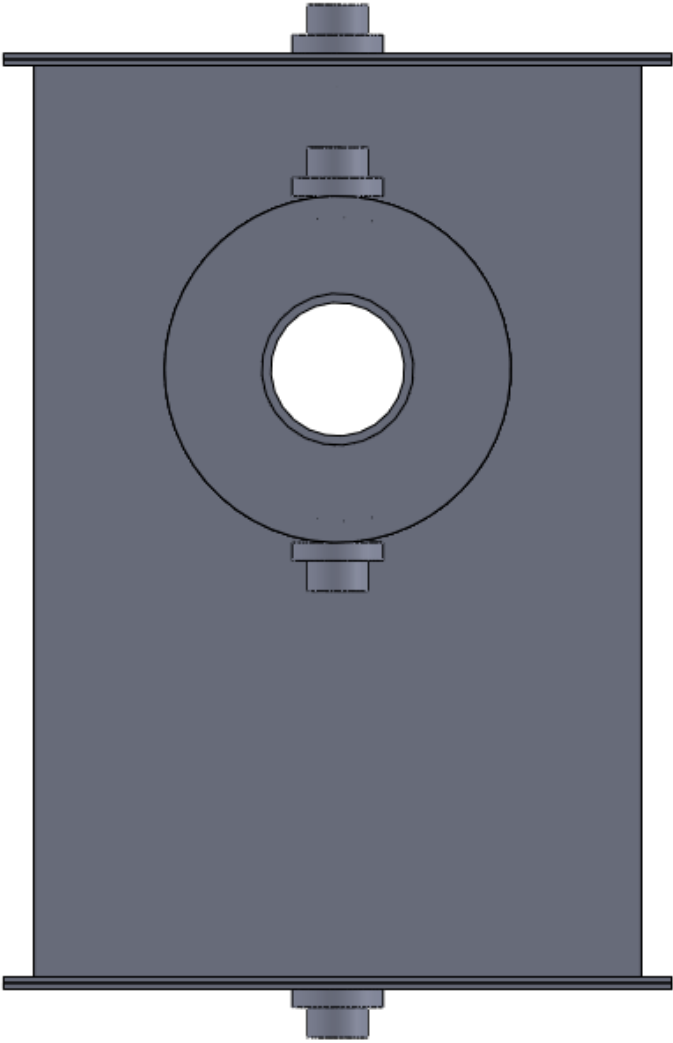

Figure 22. Dual microwave cavity sensor back view

Dual microwave cavity sensor side view

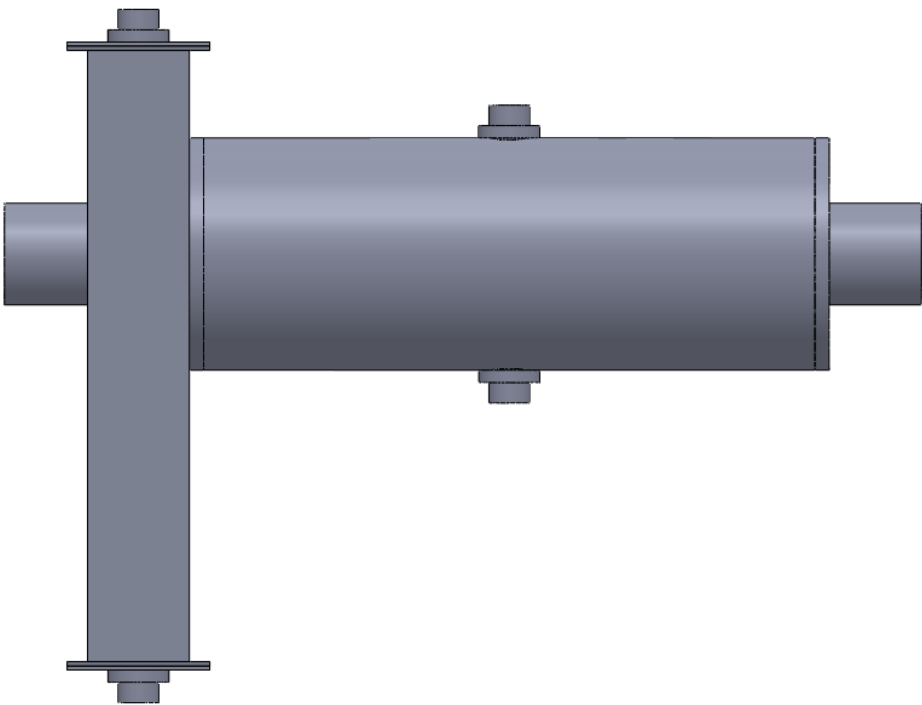

Figure 23. Dual microwave cavity sensor side view

APPENDIX D LABVIEW

Labview data record front panel

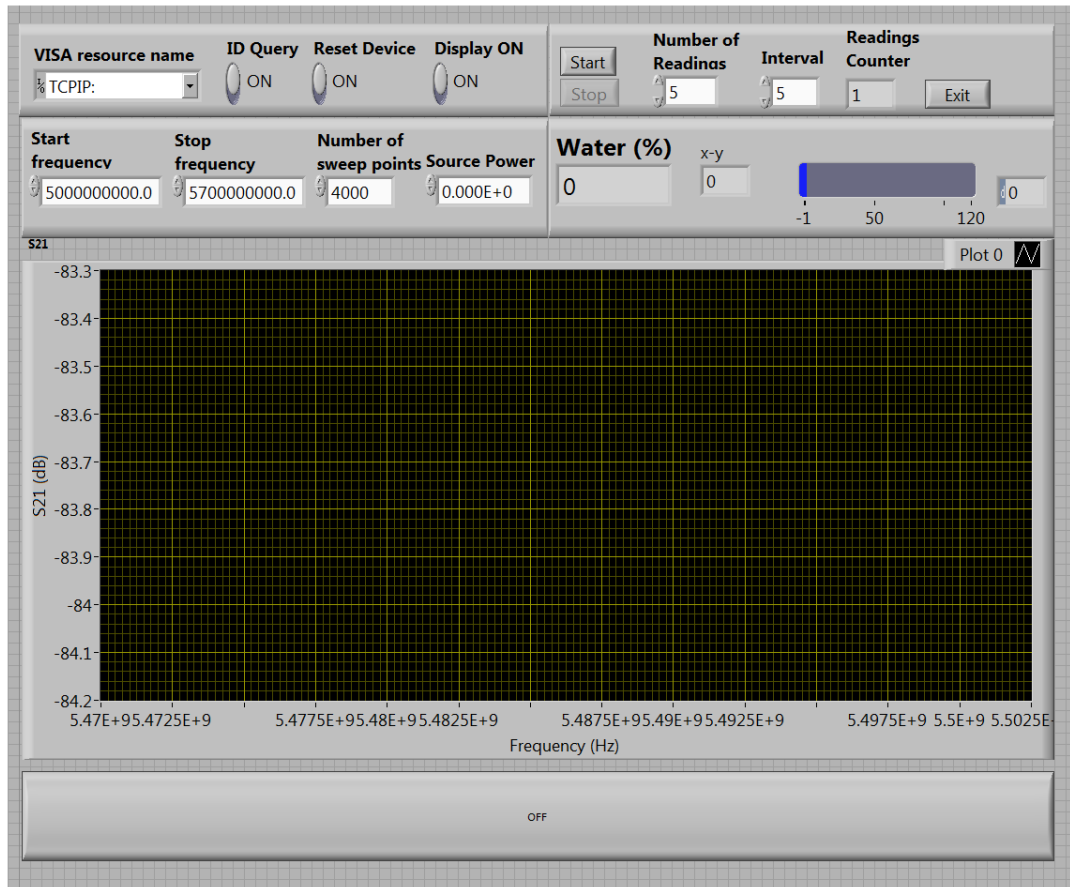

Figure 24. Labview data record front panel

Data record block diagram (first half)

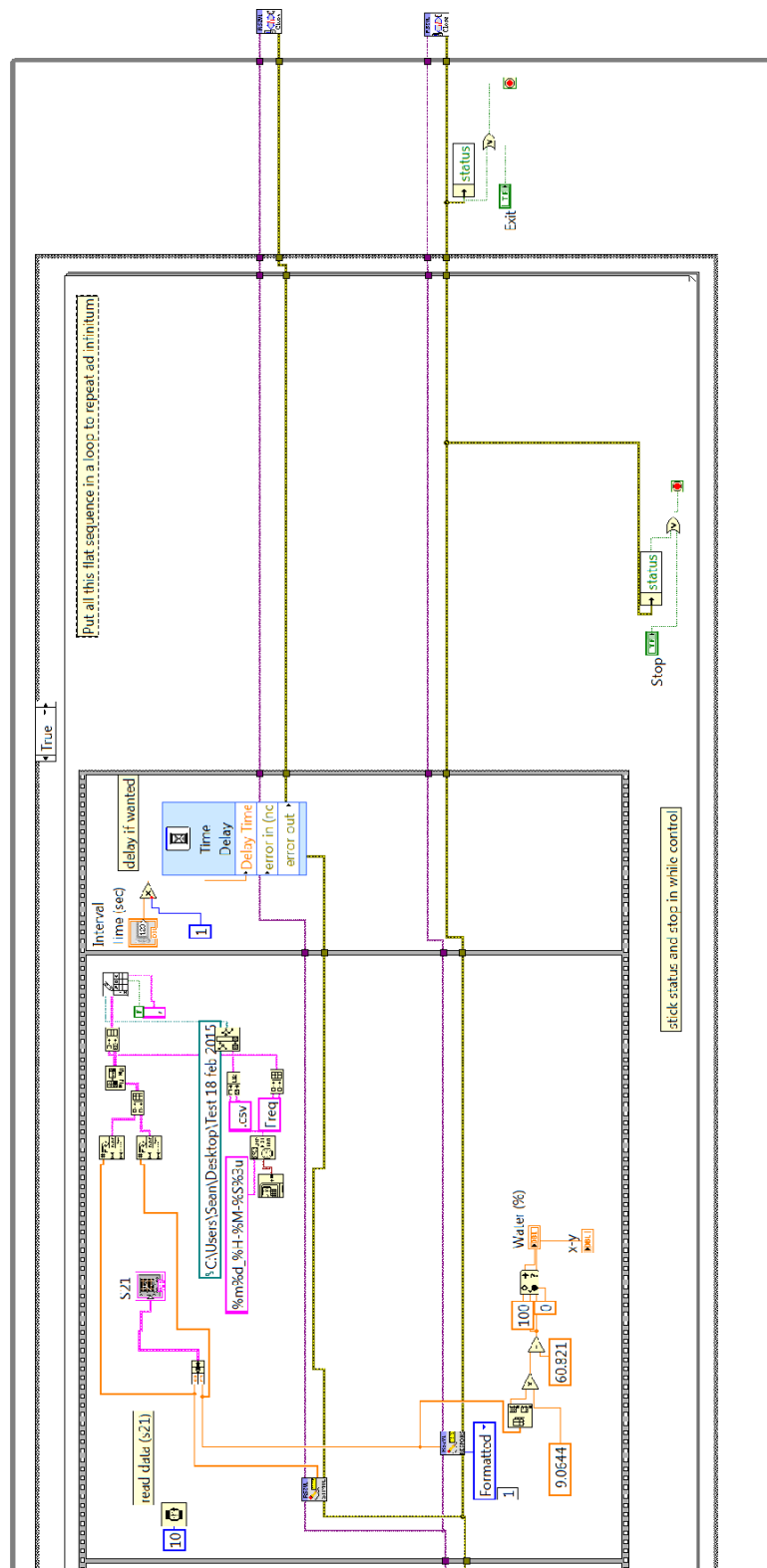

Figure 25. Data record block diagram (first half)

Data record block diagram (second half)

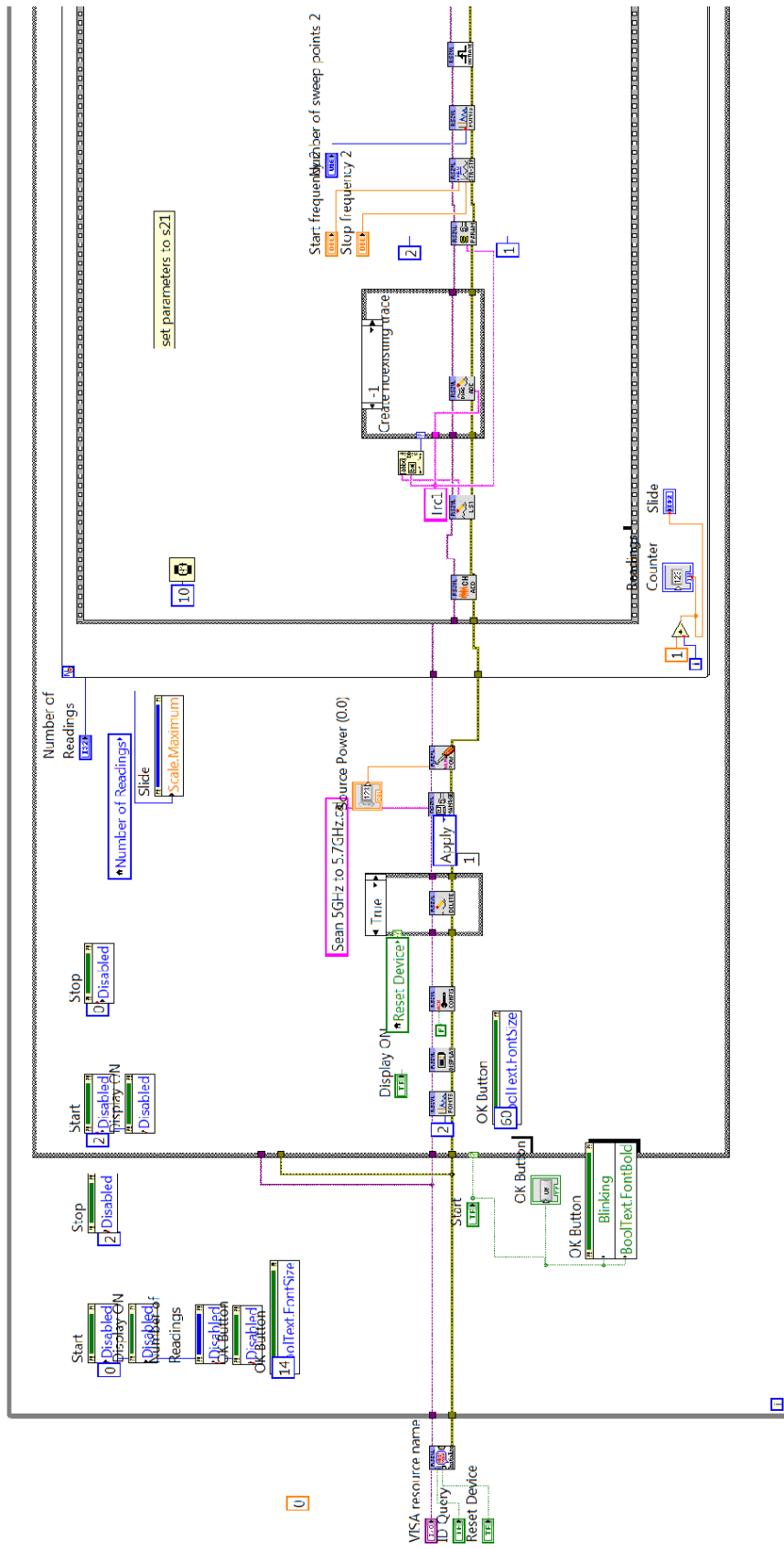

Figure 26. Data record block diagram (second half)

Labview data record and control front panel

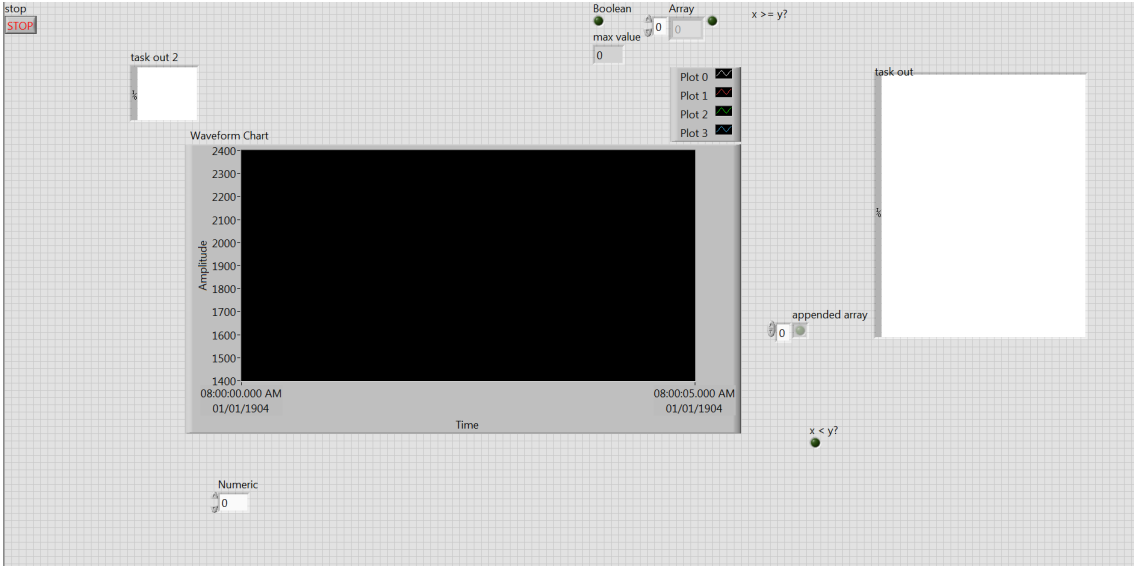

Figure 27. Labview data record and control front panel

Data record and control block diagram (first half)

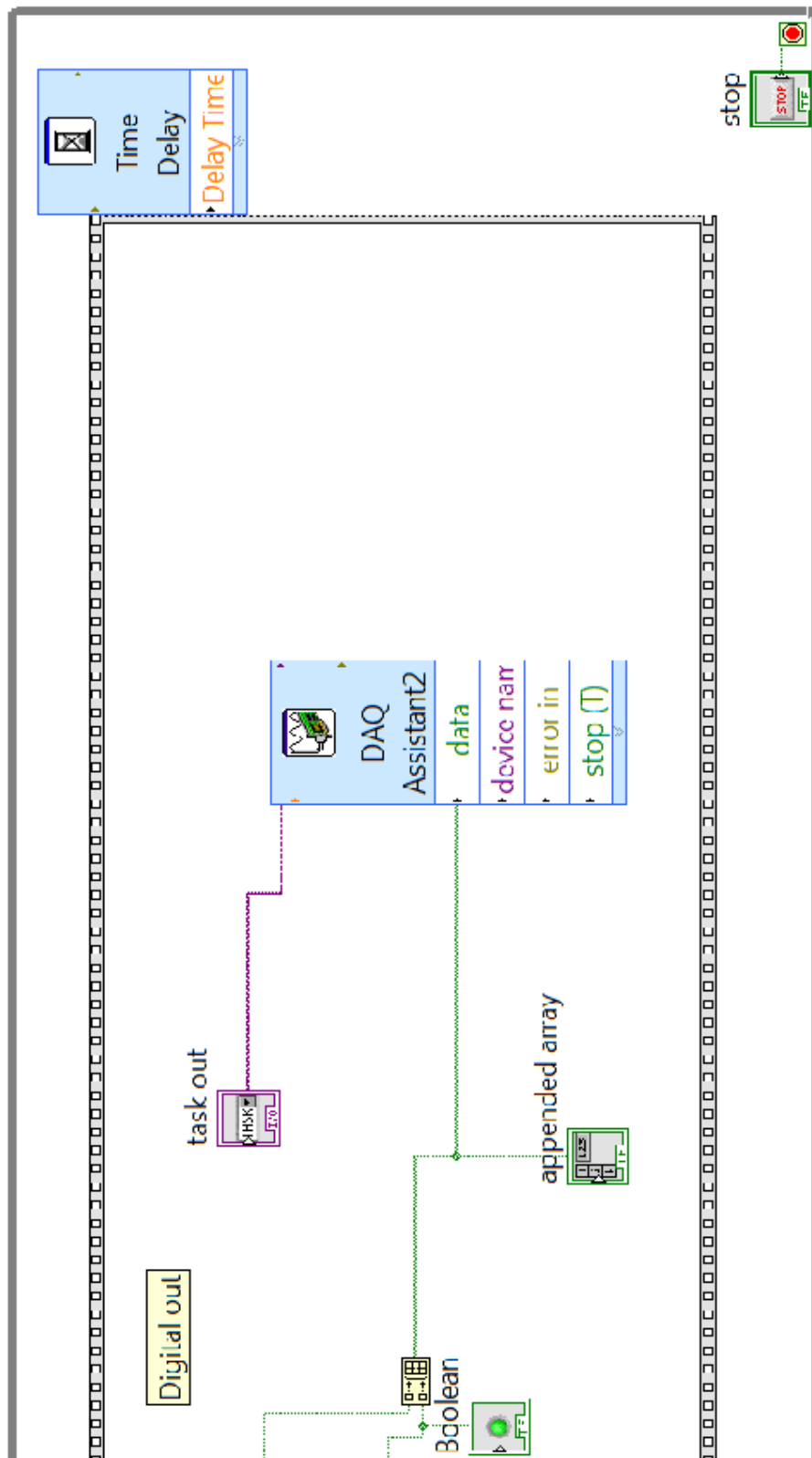

Figure 28. Data record and control block diagram (first half)

Data record and control block diagram (second half)

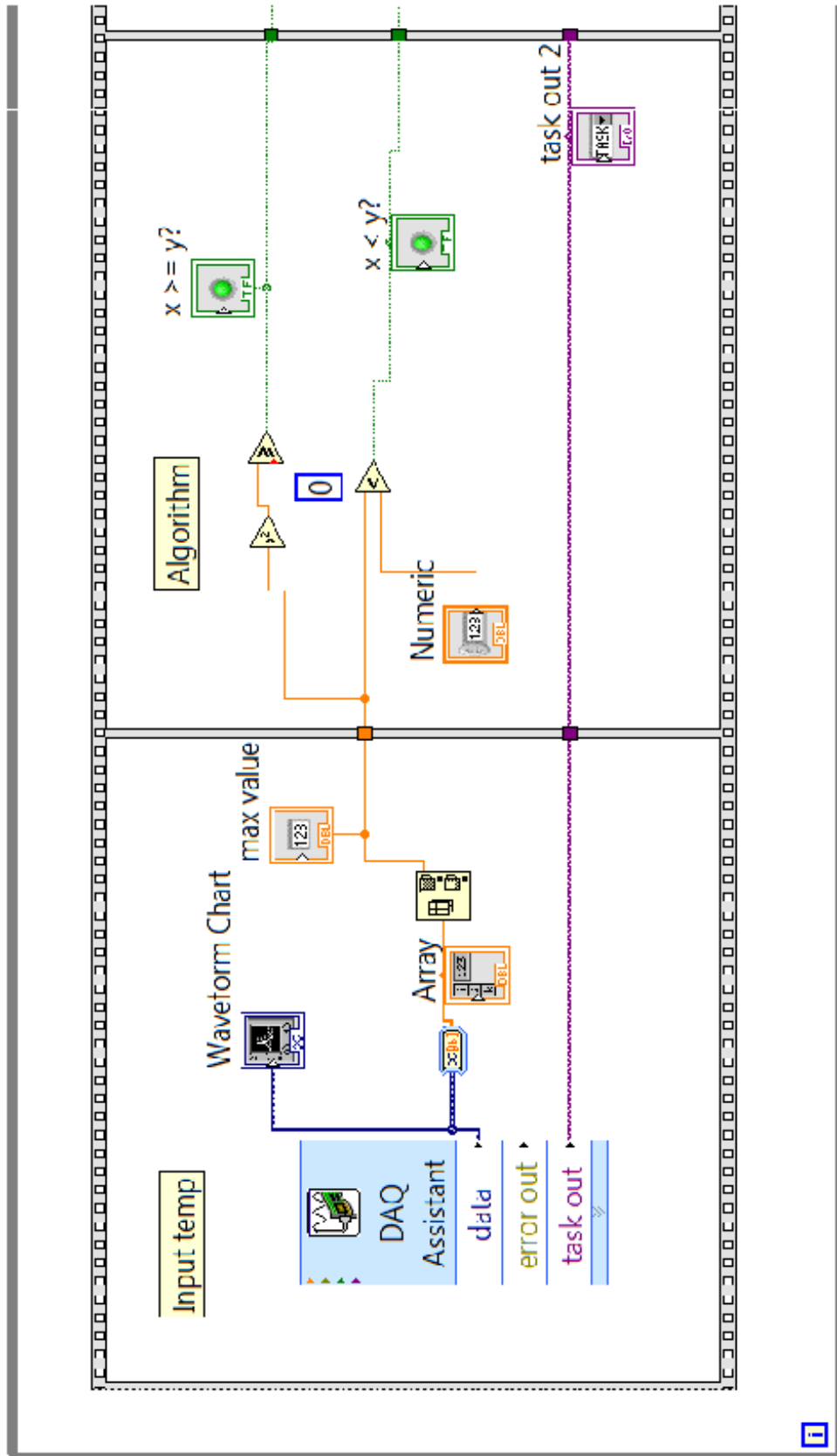

Figure 29. Data record and control block diagram (second half)