

STATISTICAL ANALYSIS OF IMPACT FORCES AND PERMANENT DEFORMATIONS OF FUEL ASSEMBLY SPACER GRIDS IN THE CONTEXT OF SEISMIC FRAGILITY

Manuel Pellissetti¹, Hannes Keßler², Frédéric Laudarin³, Domenico Altieri⁴, Andrii Nykyforchyn⁵, Edoardo Patelli⁶ and Jens-Uwe Klügel⁷

¹ Probabilistic Safety Analyst, AREVA GmbH, Germany

² Structural Analyst, AREVA GmbH, Germany

³ Structural Analyst, AREVA SAS, France

⁴ Doctoral candidate, University of Liverpool, United Kingdom

⁵ Senior Engineer, Kernkraftwerk Gösgen-Däniken, Switzerland

⁶ Lecturer, University of Liverpool, United Kingdom

⁷ Director Safety Department, Kernkraftwerk Gösgen-Däniken, Switzerland

ABSTRACT

Different criteria are used in different countries for the seismic design verification of fuel assembly spacer grids (FASG). One criterion is to limit the maximum impact forces experienced by the FASG. Another criterion is to limit the permanent deformation of the FASG. The intent of both criteria is to ensure that during or after the seismic event the reactor trip via control rod insertion is not compromised by an excessive deformation of the fuel assemblies and that the subcriticality of the core is preserved.

Irrespective of which of the two above mentioned physical quantities is used in the design verification, in the context of seismic fragility analysis both represent the demand variable, to be compared with the capacity variable (i.e. the buckling strength and the acceptable permanent deformation, respectively).

In this contribution a statistical analysis is presented separately for the permanent FASG deformations and for the maximum impact forces. The statistical analysis relates to the nuclear power plant at Gösgen (Switzerland) and is based on the ten most demanding acceleration time histories from a sample of 30 seismic ground motion scenarios according to the PEGASOS hazard study.

The analysis extends the conclusions presented in our paper at SMiRT23 and shows that – for a **given, fixed level** of the structural response variability - the **cumulative** variability of the seismic capacity strongly depends on the tolerable level of permanent deformation of the FASG.

INTRODUCTION

The seismic robustness of fuel assembly spacer grids (FASG) is a topic of considerable safety significance. A related paper was presented at the last SMiRT conference, see Pellissetti et. al. (2015)¹, including a fragility analysis of the FASG. The pertinent safety criterion consisted in a limited permanent inelastic deformation of the FASG. A key result of that paper is that the variability of the seismic capacity of the FASG is much smaller than the variability of a.) the corresponding probabilistic floor response spectra and b.) the capacity of those sub-components for which no permanent deformation was admissible.

In the present paper the predecessor study is extended to further investigate how the variability of the seismic capacity is affected i.) by the **amount** of the permissible permanent deformation and ii.) by the use of a different failure criterion used for FASG, namely the maximum impact force.

The analysis presented both in the predecessor study and in this paper relates to the nuclear power plant (NPP) at Gösgen, Switzerland, with a three-loop pressurized-water-reactor (PWR).

FRAGILITY MODELING

¹ The study presented therein will be henceforth referred to as the “predecessor study”.

The objective of fragility analysis is to estimate the actual seismic capacity of constructions, i.e. the highest level of seismic excitation that the construction can sustain without violating predefined criteria. The most widely used model for the seismic capacity (see Kennedy and Ravindra (1984)) is given by,

$$A = \bar{A} \varepsilon_R \varepsilon_U$$

where \bar{A} is the median of the seismic capacity, while ε_R (randomness) and ε_U (uncertainty) are log-normally distributed with unit median and logarithmic standard deviations of β_R and β_U , respectively. Applying fragility analysis in combination with structural dynamics the following expression is useful,

$$A = a_{ref} \cdot F$$

where a_{ref} is the (deterministic) value of the PGA adopted in the seismic analysis; the scaling factor F is the maximum scalar, by which the design ground motion can be multiplied without producing failure. The most widely used approach for estimating the parameters of the seismic fragility model (\bar{A} , β_R , β_U) is the so-called **separation of variables** approach. It consists in breaking down the scaling (safety) factor F into a product of “partial” factors:

$$F = F_S F_\mu F_{RS}$$

where F_S is the strength factor, F_μ is the inelastic energy absorption factor and F_{RS} is the structural response factor. The structural response factor is further broken down into several sub-factors influencing the response variability:

$$F_{RS} = F_{SA} F_{GMI} F_\delta F_M F_{MC} F_{ECC} F_{SSI}$$

The factors on the right refer to ground motion incoherence, damping, modeling, mode combination, earthquake component combination and soil-structure interaction.

Conceptually, in order to estimate the logarithmic standard deviations of the individual scaling factors $\beta_{i,R}$ and $\beta_{i,U}$ it is necessary to perform an additional calculation of the (cumulative) scaling factor F , in which all model variables are median centered, with the exception of the input variables corresponding to the analyzed partial safety factor. The latter ones are instead perturbed by a multiple κ of their standard deviation (to the unfavourable side). The resulting partial safety factor is denoted here as $F_{\kappa\sigma_i}$.

The variability parameter (either randomness or uncertainty) of the analyzed safety factor is then:

$$\beta_i = \frac{1}{|\kappa|} \ln \left| \frac{F_{\kappa\sigma_i}}{\bar{F}} \right|$$

The logarithmic standard deviations of the individual safety factors are combined using SRSS (square root of sum of squares), leading to the parameters β_R and β_U of the cumulative safety factor F .

STRUCTURAL DYNAMICS AND PROBABILISTIC MODELING

Analysed structures and components

The analysis presented in this paper is based on similar models and a similar set of excitation time histories as in the predecessor study. More specifically, the seismic response time histories are the result of the consistent propagation of ground motion time histories through a sequence of dedicated structural models (see also Figure 1 below):

- a) 3D-model of the reactor building, including soil structure interaction (analysis code: SASSI)
- b) 2D-model of the RPV, the RPV internals and the CRDM (analysis code: CESHOCK)
- c) 2D-model of the fuel assemblies (analysis code: KWUSTOSS)

For a description of these models the reader is referred to the predecessor study. Since the RPV internals and the fuel assembly models are 2-D, each dynamic analysis with the 3-D building model results in **two sets of excitations** for the subsequent RPV internals and fuel assembly analyses.

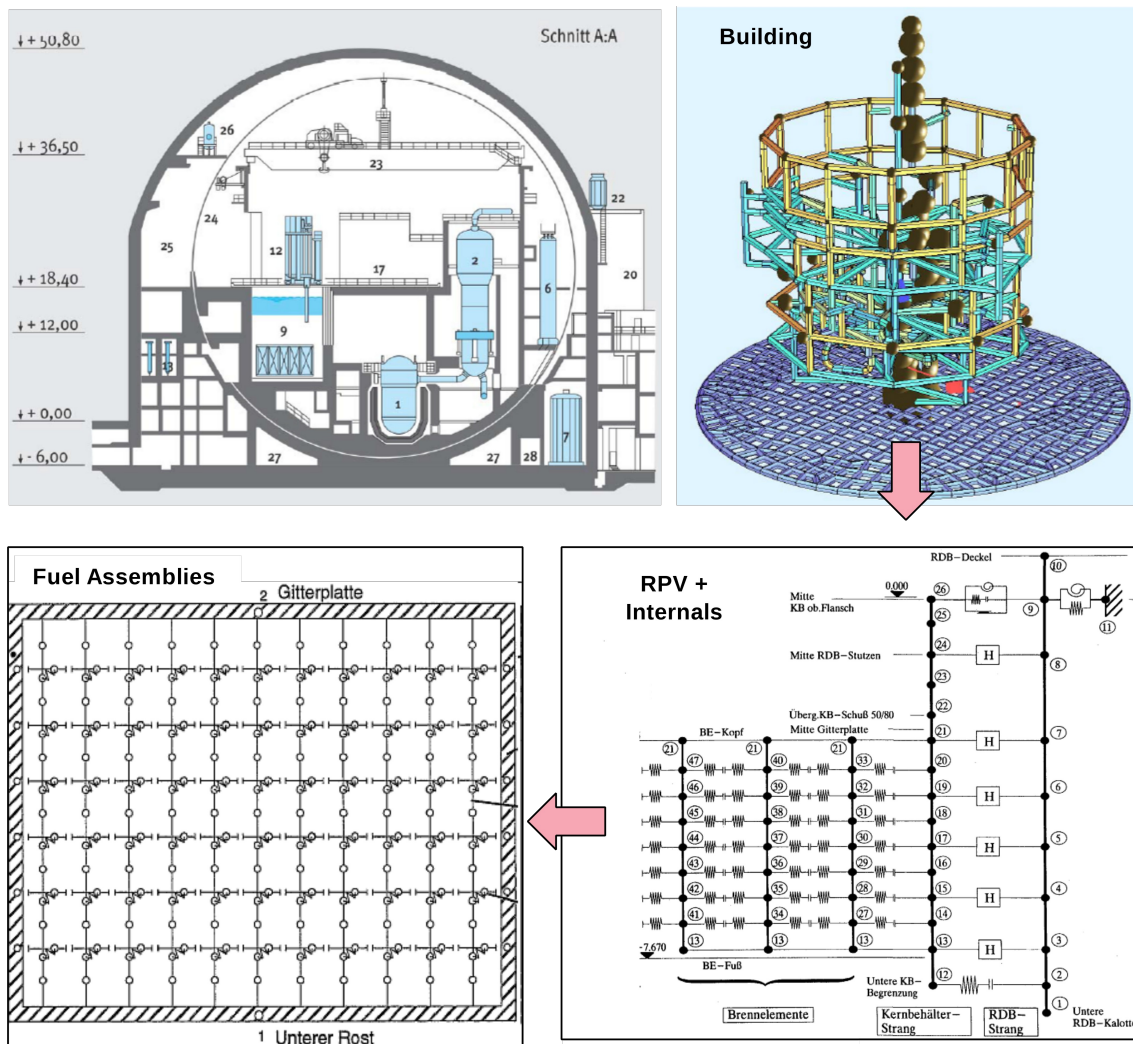

Figure 1. Section view of the reactor building at Gösgen (top left) and models used for the propagation of seismic loads to the fuel assemblies

CASAC Model

The above described sequence of models is used to study the seismic fragility for the failure criterion “permanent deformation”. For the alternative failure criterion “impact force”, the fuel assemblies (step c in the above sequence) are modeled and analysed with the analysis code “CASAC”.

The utilized row models (see Figure 1) are composed of:

- linear beams with shear strain (Timoshenko) representing the fuel assembly shear/bending,
- linear spring elements
- spring elements with gap opening (non-linear) for managing impacts between fuel assemblies and with core shrouds

The linear spring elements model the impact properties of fuel assemblies in case of one-sided impacts. When the gaps are closed (occurrence of impact) the interaction is elastic (no plastic FASG deformation). The properties of the beam elements are based on a linearization of the static non-linear response of the non-irradiated fuel assembly in reactor conditions. This one-beam representation implies that the skeleton and the fuel rod bundles dynamics are alike. The beam nodes are located at the FASG positions. Stiffness and inertial properties of the beams are homogeneous. The beams are clamped to the core plates.

Three types of linear viscous damping are introduced in the model. Modal damping is used for the beam elements, defined by damping ratios associated with the first modes of interest of the fuel assemblies. The higher modes are damped with a Rayleigh damping model proportional to stiffness. The spring elements integrate linear dampers that are used to model the impact damping properties.

The loading consists of time histories defining the motion of the rigid core plates and the shroud. Except from their small deformations, the shroud is synchronized with the lower core plate.

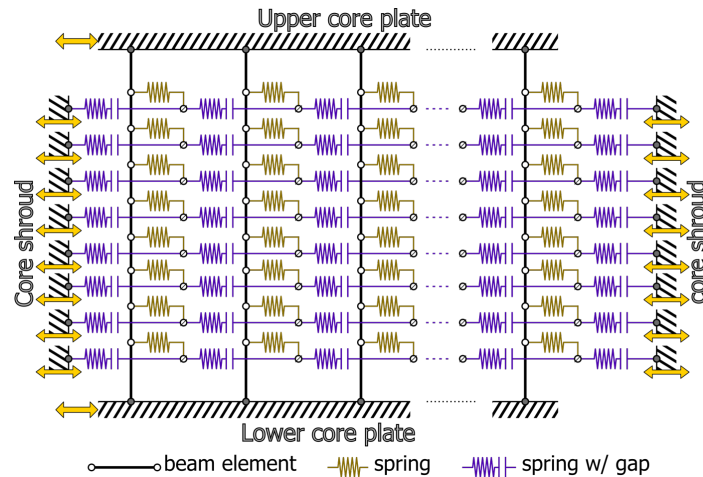

Figure 1. Fuel assembly row models implemented in CASAC

Seismic excitation

The ground motion time histories correspond to the mean uniform hazard spectra (UHS) at $10^{-4}/a$ for the Gösgen site according to PEGASOS².

Probabilistic modeling

The probabilistic modeling is unchanged with respect to the predecessor study³. A sample of 30 random ground motion time history sets⁴ is propagated through the analysis chain described above.

FAILURE CRITERION “PERMANENT DEFORMATION”

Analysis Objective

The previous study revealed strongly decreased variability of the FASG capacity. It was concluded that the underlying reason is that the failure criterion is a.) defined in terms of a maximum allowable permanent deformation (4 mm) and b.) evaluated by a non-linear dynamic analysis, accounting for the elasto-plastic behaviour of the FASG.

One of the objectives of the present study is thus to corroborate this conclusion by showing the dependence of the variability on the magnitude of the allowable permanent deformation (4 mm).

The objective of the present section is thus twofold: 1.) quantify the dependence between scaling factor and permanent deformation for each set of time histories; 2.) to identify the limiting scaling factor for different levels of admissible permanent deformation, using the dependence quantified in step 1.

Selection of the ten most demanding fuel assembly excitations

To reduce the computational effort, a sub-sample of size ten is derived from the overall sample of 60 sets of excitation time histories⁵. The criterion governing this selection is the maximum impact force occurring

² Acronym for “Probabilistische Erdbebengefährdungsanalyse für die KKW-Standorte in der Schweiz”, i.e. the probabilistic seismic hazard analysis (PSHA) for Swiss nuclear power plant (NPP) sites.

³ Refer to pg. 3 in Pellissetti et. al. (2015).

⁴ Each set consists of three ground acceleration time histories (two horizontal and one vertical).

⁵ Recall that each of the 30 analyses with the 3-D building model results in two sets of excitations for the subsequent RPV internals and fuel assembly analyses, because the RPV internals and the fuel assembly models are 2-D.

during a single time history analysis, based on an **elastic** KWUSTOSS analysis⁶. The ten sets of time histories which lead to the largest maximum impact force are considered to be the most demanding fuel assembly excitations. **The subsequent analysis is performed only with this sub-sample of size ten.**

Dependence between scaling factor and permanent deformation

For one of the preserved excitation time history sets⁷ the following Figure 3 shows the dependence between the scaling factor, applied to each of these time histories, and the permanent deformation.

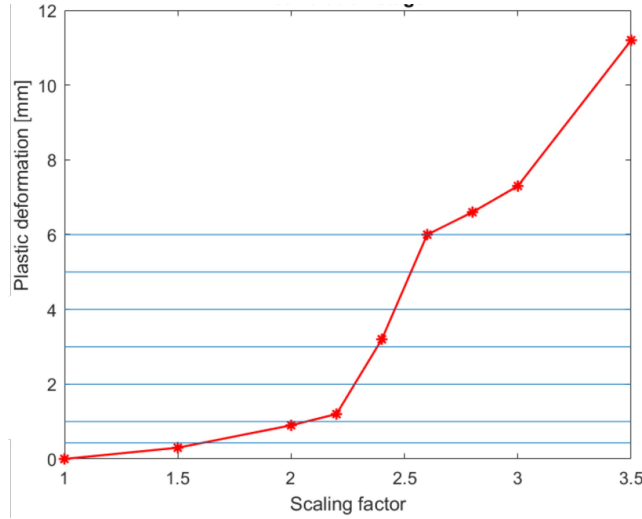

Figure 3. Scaling factor vs. plastic (permanent) deformation

The markers indicate the scaling factors for which the corresponding permanent deformation has been computed explicitly using KWUSTOSS. The linear interpolation between the markers is subsequently used to estimate the **capacity scaling factor**, for various levels of the **admissible** permanent deformation. These levels are indicated by the blue horizontal lines in the above figure. The lowest of the considered admissible permanent deformation values is 0.43 mm and corresponds - in analogy to the uniaxial yield strength definition of $R_{p,0.2}$ - to an inelastic spacer grid deformation in load direction of 0.2 % of the spacer grid width. The capacity scaling factor is defined as the maximum scalar by which the excitation time history can be scaled without violating the failure criterion, i.e. without exceeding the admissible permanent deformation (the scalar is incremented in steps of 0.1).

Distribution fitting for different levels of tolerable permanent deformation

The following Figure 4 contains the (log-normal) probability plots for different levels of the admissible permanent deformation, ranging from 0.43 mm to 5 mm. The green triangles indicate the limiting scaling factors obtained for the ten most demanding sets of time histories. These are assumed to be the ten smallest scaling factors. A log-normal distribution is fitted, using the smallest and the largest of the ten scaling factors as estimates for the 1.67- and 16.7-percentiles (1/60 and 10/60, respectively), denoted as $F_{1.67\%}$ and $F_{16.7\%}$.

More specifically, the parameters of the LN-approximation of the scaling factors are estimated as:

$$\beta = \frac{1}{|u_{16.7\%} - u_{1.67\%}|} \ln \left| \frac{F_{16.7\%}}{F_{1.67\%}} \right| = \frac{1}{1.16} \ln \left| \frac{F_{16.7\%}}{F_{1.67\%}} \right| \quad \overset{u}{F} = F_{1.67\%} \exp(\beta \cdot |u_{1.67\%}|)$$

⁶ For this analysis, the contact elements in KWUSTOSS are specified to remain elastic.

⁷ For each analysis case, i.e. a set of three acceleration time histories (two horizontal and one vertical) at the ground, the excitation of the fuel assembly model is defined by several time histories (top, bottom, core shroud).

In the above equations, $u_{1.67\%}$ and $u_{16.7\%}$ are the corresponding fractiles of the standard normal distribution, i.e. -2.13 and -0.97, respectively.

The probability paper plots in Figure 4 indicate that the assumption of log-normality is reasonable. For illustrative purposes, a full synthetic sample of size 60 (violet crosses), randomly generated with the estimated LN-parameters, is plotted as well for each of the considered levels of the admissible permanent deformation.

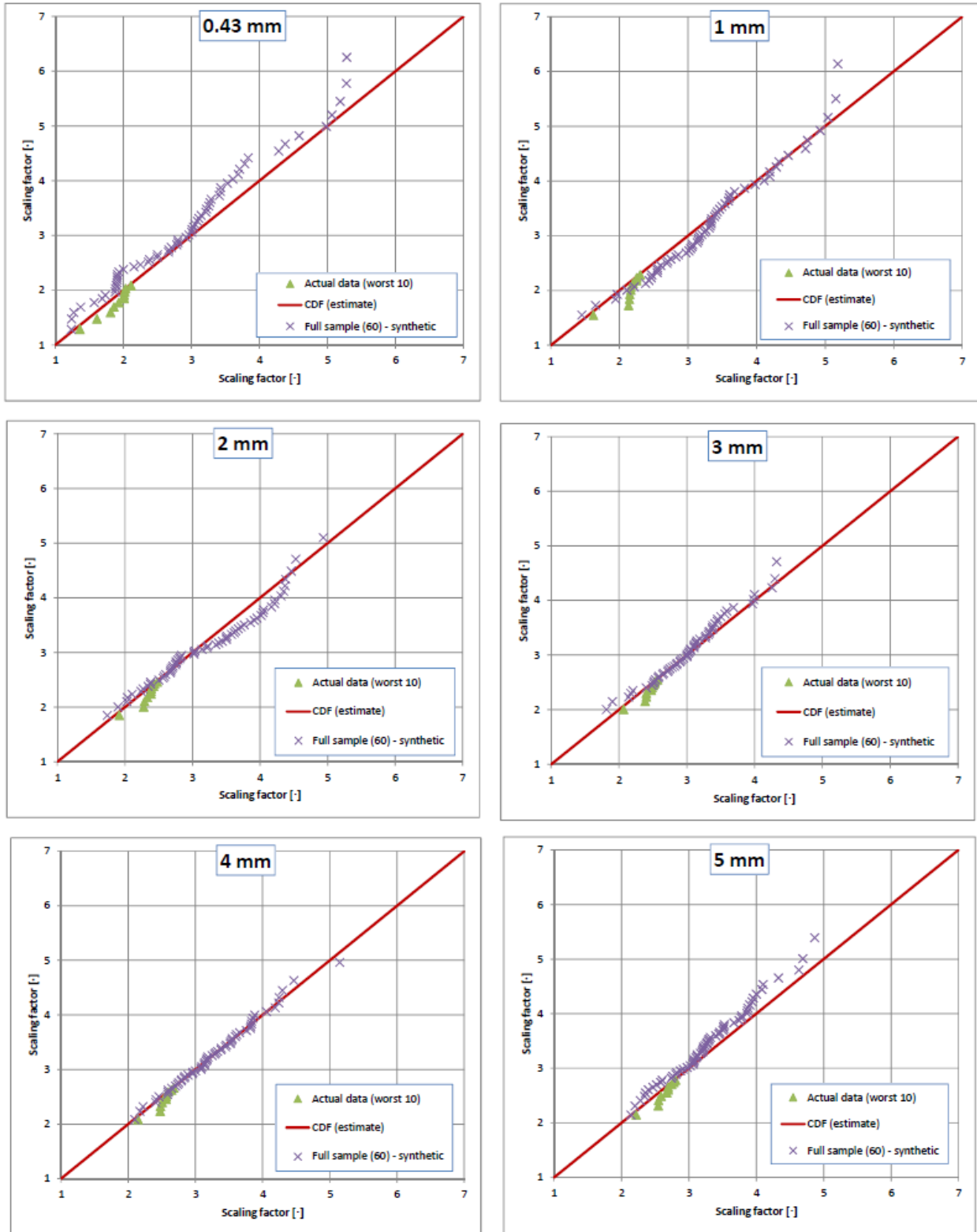

Figure 4. Probability paper plot of capacity scaling factors fitted with log-normal distribution

FAILURE CRITERION “IMPACT FORCE”

Analysis Objective

The results presented in the previous section apply to the case in which the failure criterion is defined in terms of the permanent deformation. As mentioned before, another failure criterion that is widely used in design and evaluation of FASG is defined in terms of impact forces.

The objective of the present section is to quantify the variability of the impact force for the **same** set of **excitations** as those underlying the data in the previous section⁸.

Impact force time histories

In the top left part of the following Figure 5 the occurrence of impacts and the magnitude of the corresponding impact forces (unit: Newton) is shown as a function of time, for the first of the ten considered time histories⁹. Each of the vertical beams indicates an impact between any pair of grids or between one of the two grids on the edge with the core shroud. Qualitatively, we firstly observe that impacts occur in clusters; e.g. the first major cluster occurs shortly before $t = 2$ s. Clearly, the impacts propagate (domino effect). Secondly, the impact clusters form two distinct phases; the transition can be located shortly after $t = 4$ s. The second phase is more intense, in terms of impact forces.

On the right hand side of Figure 5, the impact force time histories of **all the ten time histories** considered in the present study are **concatenated** in a single plot. This figure confirms the qualitative feature of the first time history that the impacts occur in two phases, with the second phase being more intense. Indeed, for each of the ten time histories, the overall maximum impact force occurs during the second phase.

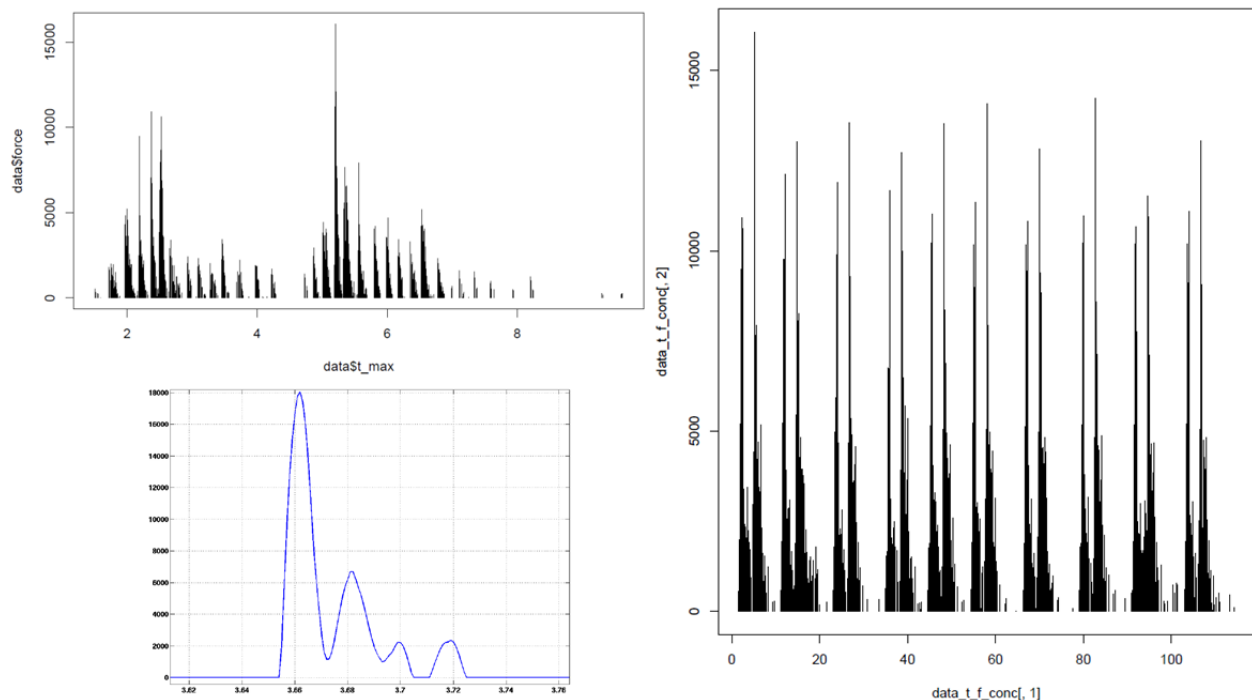

Figure 5. Top left: impact forces (any FASG) during a single time history (7-row model). Bottom left: zoomed view on the time-dependent contact force (specific FASG). Right: concatenation of impact forces (any FASG) for ten time histories

The diagram in the lower left of Figure 5 has the purpose to elucidate the precise meaning of “one individual impact”, by giving a zoomed view of the contact force evolution during a very short time

⁸ Note that the **models/analysis codes** used to compute the permanent deformation (→ KWUSTOSS) and the impact forces (→ CASAC) are different (see pg. 3).

⁹ This type of plot is denoted as „impact force time history“ in the sequel.

interval. Each time contact is lost, a new „impact“ starts; in the shown case there are two impacts, a prolonged one with three local peaks and a shorter one with a single, small peak. The plots in Figure 5 refer to the 7-row model (recall pg. 3).

Distribution fitting for maximum impact forces

In the following Figure 6 the (log-normal) probability plots of the maximum impact forces are shown for a 7-row and a 17-row model. Similar to the fitting results for the scaling factors (failure criterion “permanent deformation”) in Figure 4, the data give no indication that the log-normal approximation should be discarded¹⁰.

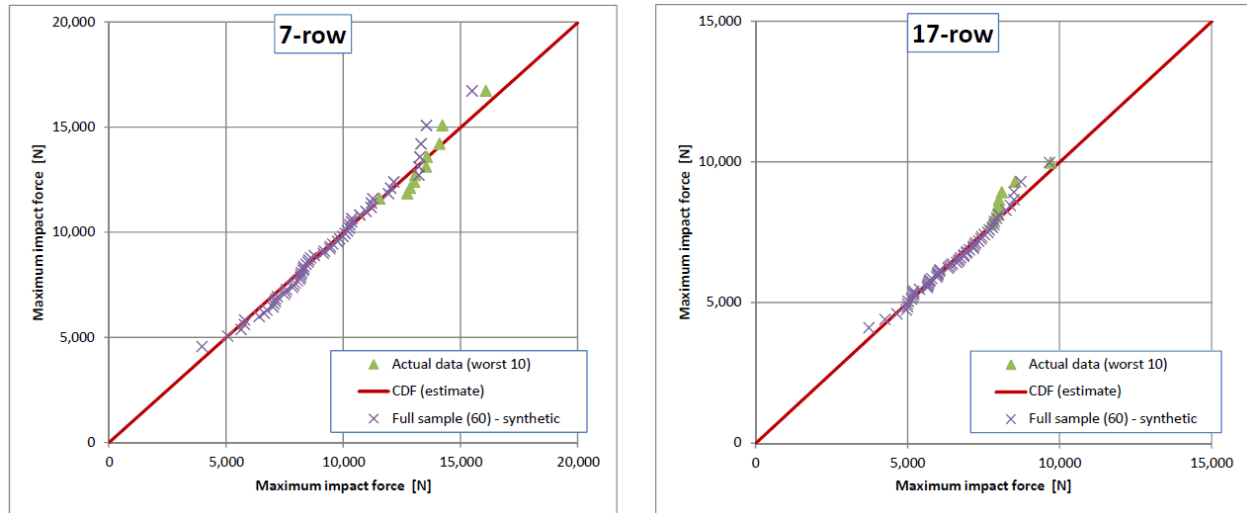

Figure 6. Probability paper plot of maximum impact forces fitted with log-normal distribution

DEPENDENCE OF THE VARIABILITY PARAMETER ON THE FAILURE CRITERION AND ON THE LEVEL OF THE ADMISSIBLE PLASTIC DEFORMATION

In the following Figure 7 the dependence of the variability parameter β (of the seismic capacity) on the **level** of the admissible plastic deformation is shown by the blue curves. The variability of the maximum impact force is indicated by the dashed red line; the variability of the 7-row model is shown, since the corresponding impact forces are significantly larger than those of the 17-row model (and hence the 7-row configuration would be governing).

The left part of the figure shows the variability parameters obtained by using the smallest and the largest scaling factor for each of the considered levels of admissible permanent deformation, i.e. by fitting the LN-distribution to the (approximate) $F_{1.67\%}$ and $F_{16.7\%}$, according to the expression on pg. 5.

Having observed in Figure 4 that in most cases the smallest scaling factor (\rightarrow approximate $F_{1.67\%}$) somewhat resembles an outlier, an alternative parameter fitting has been performed using the second smallest scaling factor instead, i.e. using the (approximate) $F_{3.3\%}$ and $F_{16.7\%}$. The resulting β are shown in the right part of the figure below.

In both cases, starting from the $R_{p,0.2}$ value (recall pg. 5) at 0.43 mm, there is a clear trend that as the admissible permanent deformation increases the variability of the scaling factor (and hence of the capacity) **strongly drops**. The magnitude of the drop is about a factor of two (left plot) to three (right plot). A moderate, but relatively insignificant, “rebound” of the variability can be observed for the two largest considered levels of admissible permanent deformation (5 and 6 mm).

The variability of the maximum impact force is significantly lower than the β corresponding to the $R_{p,0.2}$ value (around 0.38) in the left plot. However, for the alternative fitting (lowest scaling factor discarded) the variability of the maximum impact force agrees well with the β corresponding to the $R_{p,0.2}$ value.

¹⁰ This result is in line with earlier quantitative studies indicating that the log-normal model and the (generalized) extreme value model fit similarly well.

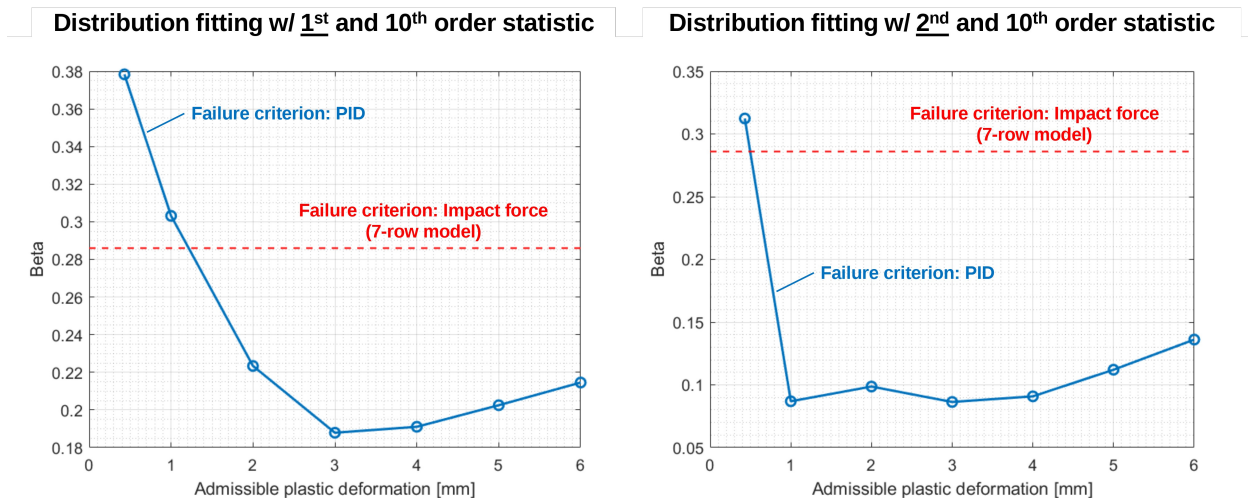

Figure 7. Dependence of β on the level of the admissible plastic deformation

CONCLUSIONS

The above analysis extends the conclusions presented in our paper at the previous SMiRT and shows that – for a **given, fixed level** of the structural response variability - the **cumulative** variability of the seismic capacity strongly depends on the tolerable level of permanent deformation of the FASG.

As the level of admissible permanent deformation increases with respect to the $R_{p,0.2}$ value (onset of inelastic deformation), the variability of the cumulative variability parameter β strongly drops. The magnitude of the drop is about a factor of two to three.

In the context of fragility analysis for NPP, for selected components – namely those with high risk relevance – it might be worthwhile to evaluate whether a similar reduction of the cumulative variability parameter β applies, provided that (limited) permanent deformation can be tolerated for the governing failure mode and the component exhibits sufficient ductility for this failure mode.

REFERENCES

- Pellisetti, M., Nykyforchyn, A., Rangelow, P., Schramm, K., Keßler, H., Klügel, J.-U. (2015). “Seismic Robustness of Reactor Trip via Control Rod Insertion at Increased Seismic Hazard Estimates,” *Transactions Structural Mechanics in Reactor Technology (SMiRT23)*, Manchester, United Kingdom.
- Kennedy, R.P. and Ravindra, M.K. (1984). “Seismic fragilities for nuclear power plant risk studies”. *Nuclear Engineering and Design*. 79, 47-68.