

## Green Applications of Carbon Nanostructures produced by Plasma Techniques

Marquidia Pacheco<sup>1</sup>, Joel Pacheco<sup>1</sup>, Ricardo Valdivia<sup>1</sup>, Alfredo Santana<sup>2</sup>, Xin Tu<sup>3</sup>, Doroteo Mendoza<sup>1,4</sup>, Hilda Frias<sup>1</sup>, Lourdes Medina<sup>1,2</sup>, Jaime Macias<sup>1,2</sup>

<sup>1</sup>Instituto Nacional de Investigaciones Nucleares, Carretera México-Toluca, Ocoyoacac. MEX.

<sup>2</sup>Instituto Tecnológico y de Estudios Superiores de Monterrey, Campus Toluca, MEX.

<sup>3</sup>Department of Electrical Engineering and Electronics, University of Liverpool, L69 3GJ, UK.

<sup>4</sup>Instituto de Investigaciones en Materiales, UNAM, CDMX, MEX

### ABSTRACT

The study of several types of plasma reactors used to obtain carbon nanostructures (CNS) is realized in the Laboratory of Plasma Applications. To obtain carbon nanotubes (CNT) thermal plasma was used and carbon nanofibers (CNF) were obtained with glow discharge. Optical emission spectroscopy was applied to correlate some plasma parameters with CNS growth. Several analytical techniques are used to study CNS obtained by both plasma techniques.

In this work, we present results concerning the use of CNS as harmful gases traps and some results of a CNT based supercapacitor prototype are also depicted.

Experimental results here detailed, show the capacity of CNF to absorb nitrogen oxides (NO<sub>x</sub>), sulfur dioxide (SO<sub>2</sub>) and, at less proportion, carbon dioxide (CO<sub>2</sub>).

CNF films were obtained by electrophoretic deposition technique and by adding CNT ink; preliminary results showed a capacitance value of 2.69 F/g. This value remains still low compared to some supercapacitors, therefore additional work has to be done in order to improve the capacitance value.

**Keywords:** Carbon nanostructures synthesis by plasma techniques, harmful gases adsorption, supercapacitors production.

### INTRODUCTION

Nowadays, carbon nanostructures already have a huge diversity of commercial applications like composites in bicycles in winning Tour de France, ship hull coated with antifouling CNT paint, printed CNT transistors on polymer film, spacecraft's shields [1] and even to prevent dental caries [2] and as cigarette filters [3]. Applications of CNF can also be observed on environmental applications to develop oxidative removal of NO from flue gas [4] and as promising anodes for sodium-ion batteries [5], for example.

In the following sections we mention other examples concerning the use of CNS on pollution treatment and to store energy.

#### *Carbon nanostructures on pollution prevention*

Nanotechnology could play a key role on the efficiently use of raw materials, energy and water and to reduce or to eliminate creation of waste. For example, nanostructure-based home

lighting could reduce energy consumption by 10% in the United States and would ultimately reduce carbon emissions by some 200 million tons per year [6].

An additional example is the use of carbon nanotubes in computer displays; they may further diminish the environmental impacts by eliminating toxic heavy metals and drastically reducing material and energy use requirements, while providing enhanced performance for consumer needs [7].

### ***Carbon nanostructures on water treatment***

In 2015, around 663 million people worldwide still used unimproved drinking water sources [8]. As a particular example, wastewater discharges containing an oversupply of nutrients like nitrogen and phosphorous, induce the eutrophication of water bodies, developing cyanobacteria that, in turn, produce dangerous toxins (i.e microcystin) [9]. The accidental ingestion of these toxins could produce symptoms like abdominal pain, nausea, vomiting, diarrhea, headache, atypical pneumonia and elevated liver enzymes [10].

Consequently, it is urgent to implement water treatment in affected areas; recent advances in nanotechnology could provide a solution in developing next –generation water supply systems. For example, concerning organic molecules removal, CNT have higher efficiency than activated carbon because the  $\pi$  electron rich CNT surface allows  $\pi$ - $\pi$  interactions with organic molecules [11]. CNF could also be used to remove phenols from polluted water [12] certainly due to physical properties as high surface area, fine diameter and porous structure. These properties allow CNS to be used as filters on bacterial removal [13, 14] and viral pathogens removal from water [15, 16, 17,18]; this could be explained by the fact that CNT cause physical perturbation of the membrane cell and disruption of specific microbial processes [19]. Other studies [20, 21] report promising results of heavy metal removal with CNT; the adsorption of these metals is mainly effectuated through electrostatic attraction and chemical bonding [22].

Other examples of applications of nanotechnology in water and wastewater treatment could be found in [23, 24, 25, 26]. From the researches briefly described here, authors emphasize about the development of additional studies for immobilization of nanomaterials before the application of this technology in drinking water treatment.

### ***Carbon nanostructures on air pollution treatment.***

In 2012, an estimated of 3.7 million deaths worldwide were attributable to ambient air pollution; 3 % of these deaths were children under the age of five years [27]. CNS could also contribute to diminish air pollution by adsorbing toxic gases like nitrogen oxides (NO<sub>x</sub>), carbon dioxide (CO<sub>2</sub>) and volatile organic compounds (VOCs).

The adsorption of NO<sub>x</sub> on activated carbon fibers at room temperature was reported in detail elsewhere [28]. Regarding the capture of CO<sub>2</sub> by CNT, the performance of its adsorption increases with the augmentation in relative humidity at low temperatures. The CO<sub>2</sub> adsorption is enhanced when CNT are modified or combined with chemical solutions like polyethyleneimine or ethylene diamine [29]. Others studies show the superiority of CNT over activated carbon on the adsorption of dioxins [30] and even over activated carbon and  $\gamma$ -Alumina [29].

## ***Carbon nanostructures applied in energy storage and renewable energy***

Energy storage is an important issue for economic and ecological plans [31]. Actually, in the power generation industry, distribution and supply systems occur only in one direction: from power plants to consumers, which often involves significant energy losses with emissions of toxic compounds, mainly greenhouse gases [9, 32].

Between 2012 and 2040, an increase of 48% worldwide consumption of marketed energy is expected [33]. The energy storage capacity in the world was about 125 GW in 2008. This capacity represents 3% of all electricity produced that year (3900GW) [34, 35]. The storage capacity required to solve the charge and discharge cycles is around 8% [36]. This means that there is a significant deficit on energy storage lied with financial losses and a substantial footprint on the environment.

Energy storage becomes transcendent in generators working, for economic reasons, at full capacity, as in nuclear industry [37], as well as new sources of renewable energy [38]. The greatest potential for carbonaceous nanomaterials for applications lies in solar energy applications, fuel cells and supercapacitors.

Thin films of CNTs (single walled nanotubes) are studied because their low cost, high conductivity, flexible and transparent anode replacement on photovoltaic architectures [39]. For fuel cells, the use of CNT as a catalytic support could reduce Pt consumption by 70% compared to black carbon [40].

Actually, new ways to store energy are being explored, as example, carbon nanostructures due to their high surface area, can convert capacitors (low storage capacity with quick charge/discharge) to supercapacitors which combine the advantages of capacitors and batteries (high storage capacity with quick charge/discharge) [41, 42, 43]. Capacitance in electrodes obtained from natural sources is difficult to measure, due to oxygen functional groups present on the carbon surface [44]. Concerning gels and cryogels with carbon they have a significant surface area, good conductivity and high energy density [45], however the cost of production is high, consequently now some studies are performed to substitute, as an example, the resorcinol [46].

There exists a large variety of supercapacitors based on carbon as is well reported in [47]. Concerning the use of carbon nanostructures as supercapacitors, there is a significant progress as demonstrated in [43, 48, 49, 50]. However, existing research requires focusing on the improvement of storage capacity, lifetime, safety, size, operation and maintenance requirements and costs of synthesis [51].

## ***Synthesis of carbon nanostructures by means of plasma techniques***

To produce CNS several techniques are generally used: the chemical vapor deposition (CVD) [52], and some based plasma techniques as laser-ablation [53] and electric arc discharge [54]. These systems normally involves gas phase processes; however experiments under other atmospheres like liquid nitrogen or water have also been tested [55, 56, 57, 58] obtaining comparable results than “traditional” techniques.

Other plasma methods comprise plasma enhanced chemical vapor deposition (PECVD), microwave plasma CVD (MPECVD) and glow discharges. CVD requires temperature range

around 700–1000 °C, discarding the use of some substrate materials (glass, some polymers). Plasma energy replaces some of the heat energy, allowing gas dissociation and nanotube formation to take place at lower temperatures; for example, MPECVD reaches 200°C [59] and PECVD around 600-700°C [60]; an additional advantage of PECVD is that electric field aligns the nanotubes during growth [61]. The duration of CNS deposition on CVD technique is long and sometimes goes beyond some hours. The use of plasmas considerably diminishes time to 20-150 minutes for MPECVD [51], 45s to 10min for PECVD [62] and 3-4 minutes for electric arc and glow arc discharges [63].

In this case, the article focuses on environmental applications of CNS, their synthesis by plasma techniques and some results of toxic gases adsorption and the assembly of a preliminary supercapacitor prototype.

## EXPERIMENTAL DETAILS

### *CNS synthesis by plasma*

To avoid the formation of compounds rather than CNS, an inert gas has to be used; in this case, the reactor was filled with helium at 600mbar. The plasma is created between two vertically aligned graphite electrodes when the electric current passes through. At the lower position, the anode contains a catalytic mixture (1%at Ni, 3.2%at Y, 95.8%at C) that ionizes in the plasma. CNS are formed at the plasma periphery and are deposited at the upper electrode and on the walls of the plasma reactor.

Plasmas with different physical properties (density of ions and molecules, temperatures) could be obtained by varying the electronic characteristics of power source. In this article, results obtained from the study of a glow-AC electric arc and DC electric arc discharges will be reported. The schema of the plasma reactor for both plasmas used is exemplified in Figure 1.

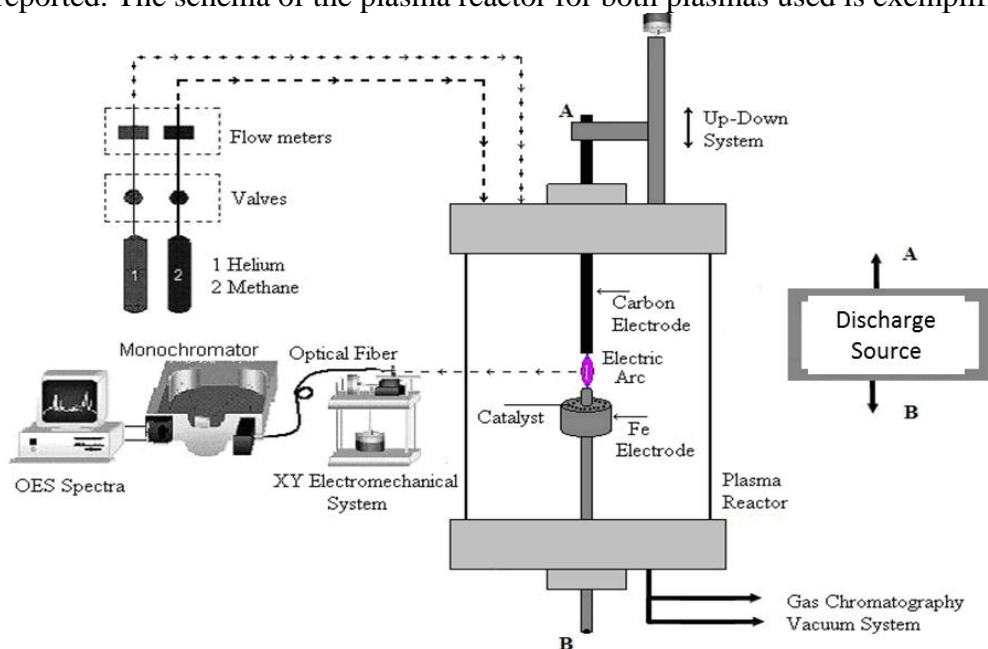

**Figure 1.** Plasma reactor used to synthesize CNS

The DC electric arc is obtained at 30V and 80A, whereas the ignition of the glow discharge (i.e non-thermal plasma or not in thermodynamic equilibrium) occurs at approximately 500 V peak and 10 mA at 40KkHz. After the warm-up of electrodes, a mixture gas (He at 0.3 L/min, CH<sub>4</sub> at 0.1 L/min) is added until atmospheric pressure is reached. While pressure increases, voltage drops to 50V and current increases to 1A. Finally, the glow-to-arc transition is completed by adjusting the operating frequency at 45-kHz until a steady discharge is obtained.

For plasmas in departure from local thermal equilibrium, the rotational, vibrational and excitation temperatures from electrons can differ from those of the heavy species temperatures. Taking into account the relation between the rotational and translational states, the rotational temperature is derived generally from the temperature of heavy particles. Then, the temperature of heavy particles can be obtained from the measurement of the rotational temperature using the Swan band situated at 516.61nm [64]. The Swan Band of molecule C<sub>2</sub> was discovered in 1856 when studies were carried out on flames containing carbon components. Since then, this technique has been applied by numerous researchers for the determination of temperatures, the calculus of these parameters are described elsewhere [65]. In this case, for OES analysis, a Jobin Ivon monochromator iHR 550 with a focal length of 550 mm and a resolution of 0.025 nm was used.

After the plasma is extinguished the carbonaceous product is collected from the electrodes and the soot-like deposit from the reactor wall; then it was purified with toluene during 5 min, the solvent is evaporated slowly. The product obtained is exposed to ultrasonic treatment in iso-propilic alcohol for 10 minutes and finally it was analyzed by scanning electronic microscopy (SEM) and transmission electronic microscopy (TEM).

### ***Gas adsorption by CNS***

CNS obtained by plasma techniques are placed into a stainless steel container, between a cellulose acetate fiber and a millipore membrane. Different concentrations of nitrogen oxides (NO<sub>x</sub>), sulfur dioxide (SO<sub>2</sub>) and carbon dioxide (CO<sub>2</sub>) gases sparely flow through the container and a gas analyzer (PG250 Horiba) monitors their concentrations (see Figure 2).

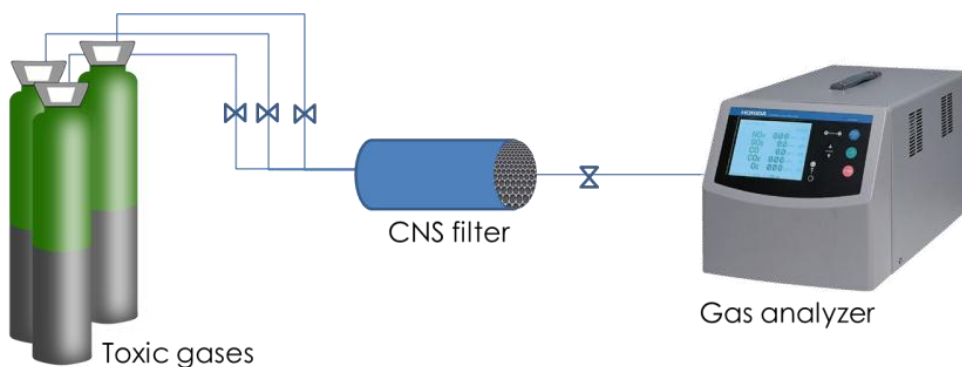

**Figure 2.** Filter with CNS to adsorb toxic gases.

The energy activation was calculated in order to know the sorption mechanism of toxic gases  
 By following the equation 1 (first order kinetics adsorption) is possible to obtain this energy:

$$\ln(-\ln(1-\alpha)) = \ln \left[ \frac{A}{\beta} \frac{RT^2}{E_a^{des}} \right] - \frac{E_a^{des}}{R} \left[ \frac{1}{T} \right] \dots \dots \dots (1)$$

Where,

$T$ : temperature

$R = 8.134 \text{ J/mol-K}$ ,

$A$ : pre-exponential factor ( $\text{s}^{-1}$ )

$\beta$ : heating velocity (K/min)

$E_a^{des}$  : energy activation

$\alpha$  is the weight loss in function of  $T$

### ***Supercapacitor assembly with CNS***

Two methods were used to deposit CNS on aluminum foils that would be serving as electrodes in the supercapacitor: the electrophoretic deposition and by adding a CNT ink.

The electrophoretic deposition technique has advantages as short formation time and simple apparatus [66]; this technique would be then used in this work to deposit CNS on substrates.

A DC voltage of 11V is applied between two parallel copper electrodes. The electrodes are immersed in a solution of CNT and KOH at 1M (i.e Figure 3). The time of electrodeposition was 11 minutes.

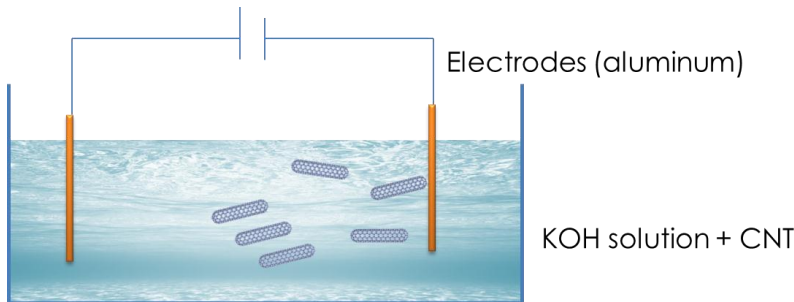

**Figure 3.** Electrophoretic deposition of carbon nanotubes.

The second method to deposit CNS into aluminum foils is by simply adding CNS ink prepared by mixing 50mg of polyvinylpyrrolidone (PVP) in 100ml of ethanol. Then, CNT were added to the solution and this mixture was submitted to ultrasound for 3 hours [67].

The electrodes, obtained from both methods described before, are placed on a dielectric (porous acetate) and a 1M solution of KOH is used as electrolyte solution. Electrodes and porous acetate are imbibed with the electrolyte solution. The role of the porous acetate is to allow the transit of charged particles. The total weight of this system is 0.112g. The capacitance is measured with a specific multimeter (Figure 4).

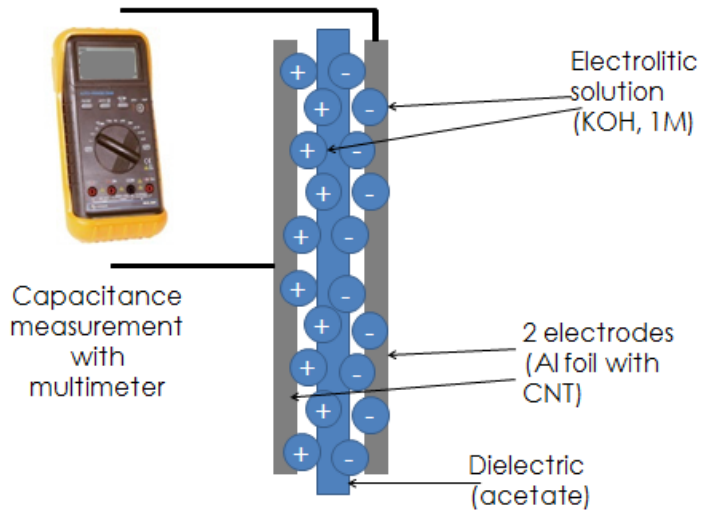

**Figure 4.** Supercapacitor prototype.

## DISCUSSION

Products obtained with two plasma techniques described before are quite different. In the glow-AC discharge the main product obtained is accumulated in both electrodes whereas in a DC electric arc the product is only deposited on the cathode. It is worth to note that the main product accumulation is formed in both electrodes because of the alternative current in glow-AC discharge.

### *Characterization of CNS by Electronic microscopy*

Micrographs obtained from SEM study shown carbon nanofibers (CNF) of 80nm width obtained with the glow-AC discharge (Figure 5). Concerning the synthesis with a DC electric arc reactor, CNT were the most representative morphology (Figure 6).

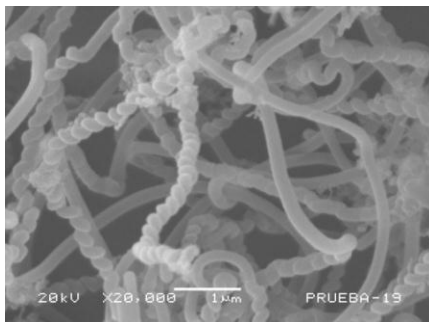

**Figure 5.** CNF obtained with a glow-AC electric arc technique.  
(bar dimension 1µm)

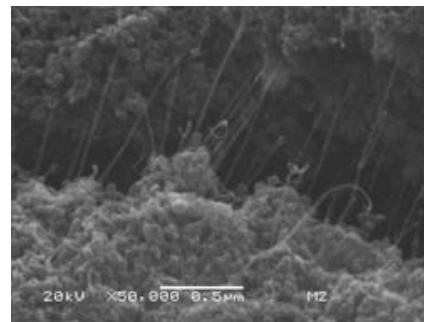
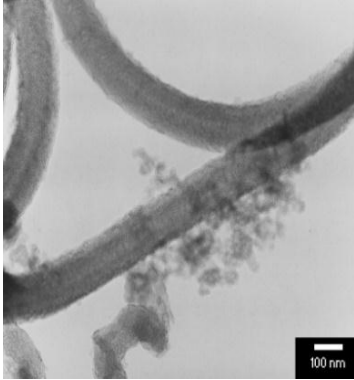

**Figure 6.** CNT obtained with a DC electric arc technique.  
(bar dimension 0.5µm)

TEM micrographs confirm crowded CNF when glow-AC discharge is used. CNF diameters vary from 30nm to 200nm. Figure 7 shows a CNF with diameter of about 120nm; [68]

obtained similar morphological structure, using a plasma reactor with twelve-phase alternating current discharge and 3 kW of power.

CNTs of around 3nm diameter are obtained with the DC electric arc method as can be appreciated on TEM micrograph (figure 8), similar results were obtained in Mansour [69].



**Figure 7.** CNF obtained with a glow-AC electric arc technique. (scale bar 100nm)

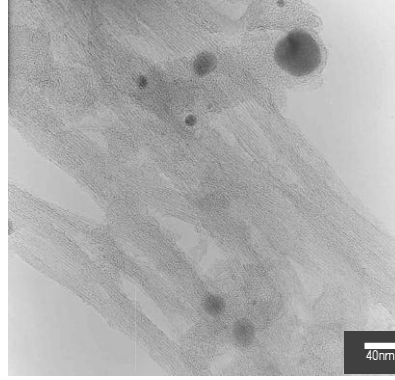

**Figure 8.** CNT obtained with a DC electric arc technique. (scale bar 40nm)

#### ***Characterization of physical properties of plasma by optical emission spectroscopy***

Temperature values of around 4800K are obtained in a *glow-AC electric arc* technique. This is enough temperature to accomplish the sublimation of the catalysts, the carbon and the methane. Unfortunately, the diagnostic cannot be prolonged until the final of the experiments, because dusty plasma rapidly fills out the reactor, and consequently, the spectral lines could not be clearly distinguished from the background, leading to a relatively large uncertainty under these conditions [63].

Temperatures profiles and  $C_2$  densities obtained in a *DC electric arc* are respectively depicted in figures 9 and 10. By comparing the results with respect to graphite anode, both the temperature level and temperature gradients decrease when using (Ni/Y) catalysts (see figure 9b).

This could be explained because the electric conductivity in plasma augments in presence of metals and then heat losses in plasma by electrical conductivity augments.

$C_2$  densities profiles are more homogeneous when catalysts are present (figure 10b); gradients of these profiles are less marked compared to plasma formed when no catalysts are used (figure 10a) [70].



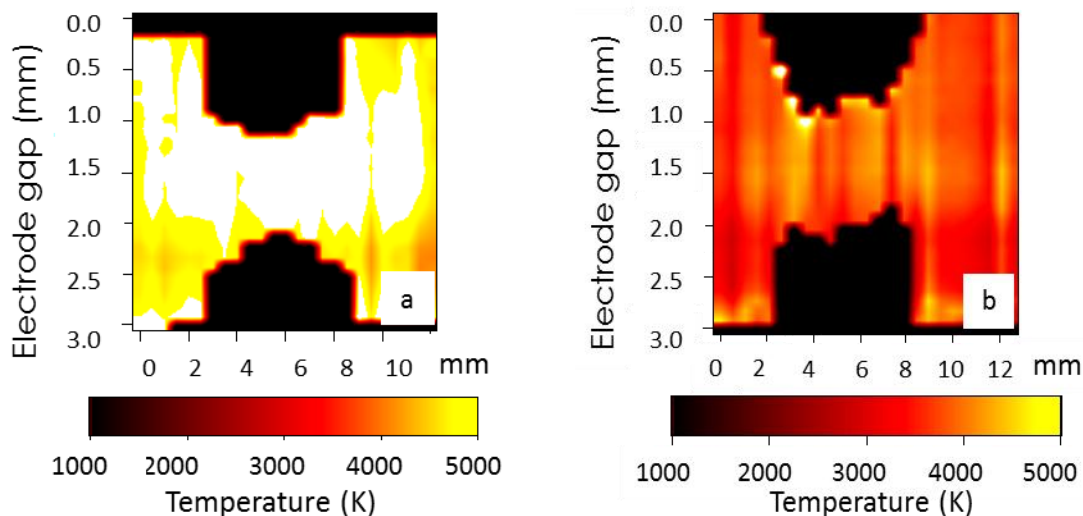

**Figure 9.** Temperature distribution in a DC electric arc around electrodes. (a) Temperature when graphite anode is used (without catalysts) and (b) Temperature when doped anode is used (Ni/Y)

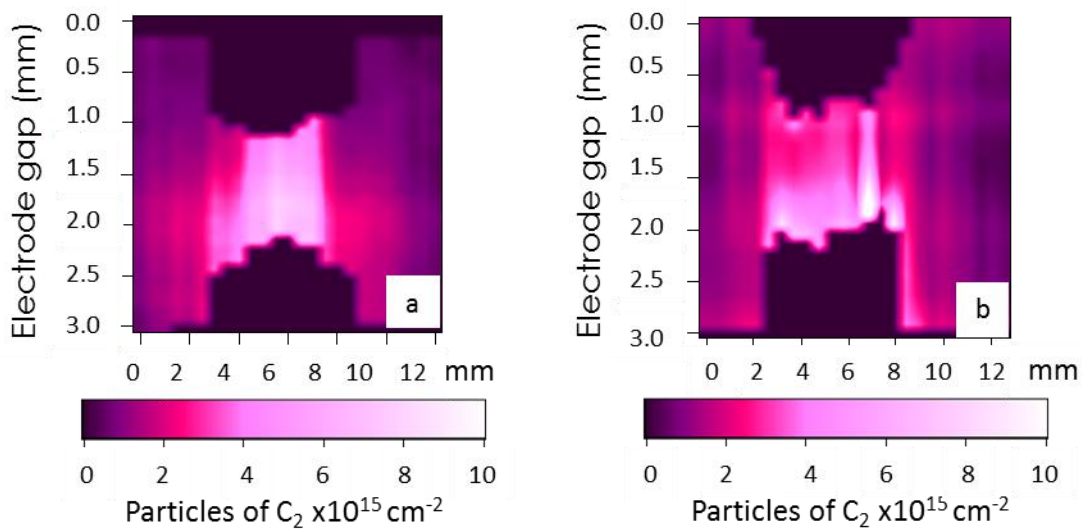

**Figure 10.** C<sub>2</sub> density distribution in a DC electric arc. (a) C<sub>2</sub> density when graphite anode is used (without catalysts), (b) C<sub>2</sub> density when doped anode is used (Ni/Y)

### *Adsorption of gases with CNF*

The energy of activation ( $E_a^{\text{des}}$ ) of CNF used to adsorb several gases was calculated following the equation 1 and was reported in Table I.

**Table I.** Activation Energy of CNF [63,71]

Analyzed sample	$E_a^{des}$ (kJ/mol)
Only CNF	15.173
CNF with NO <sub>x</sub>	109.345
CNF with SO <sub>2</sub>	13.437
CNF with CO <sub>2</sub>	40.964

The relatively low values of activation energy suggest a physical absorption. These results are similar to values obtained by some others authors (for CNS the energy activation is in the range of 10 KJ/mol-100KJ/mol [72,73,74]). The advantage of the physical adsorption is that toxic gases could be removed from CNF fluid bed by employing physical means such as a pressure camera.

The adsorption rate of studied gases is summarized on Table II. As it could be seen NO<sub>x</sub> and SO<sub>2</sub> are adsorbed in a superior rate than CO<sub>2</sub>, possibly because they are polar molecules [75].

**Table II.** Adsorption rate of several gases by CNF [71].

Gas	Initial concentration (ppm)	Final concentration (ppm)	Adsorption rate (%)
SO <sub>2</sub>	154	134.75	12.5
NO <sub>x</sub>	300	36.9	87.7
CO <sub>2</sub>	6800	6596	3.7

### *Supercapacitor assembly with CNS*

Both methods depicted on experimental description section were utilized. On figures 11 and 12 are respectively represented the deposition of CNT on copper foil and the thickness of the ink layer.

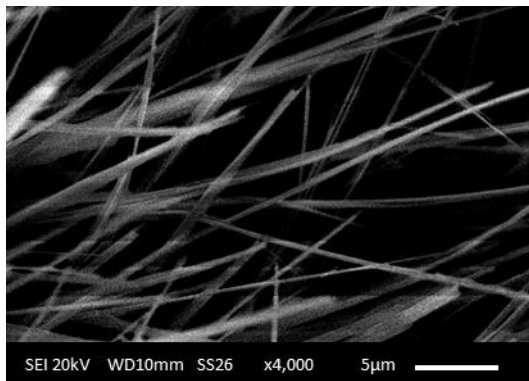

**Figure 11.** Deposition of CNT on aluminum (scale bar 5µm)

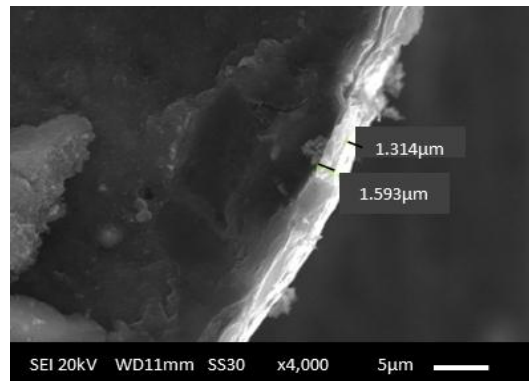

**Figure 12.** Thickness of the ink layer (scale bar 5µm)

Results obtained with CNS ink are only reported here; specifically a capacitance value of 2.69 F/g was obtained. This value remains low compared with results obtained by other authors, i.e., 20.31 F/g [59] and 20-100F/g using activated carbon [76].

## CONCLUSIONS

From the results here presented, it can be appreciated that low gradients of temperatures and C<sub>2</sub> densities would induce better yield of nanotubes production. The use of Ni/Y as catalyst enhances the production of carbon nanostructures.

Promising results to adsorb toxic gases using raw nanotubes were reported, however it is necessary to improve our prototype of supercapacitor, by adding, for example, a different electrolyte solution and by changing the dielectric barrier with a more porous material.

Preliminary results suggests that nanotechnology could play a key role on the efficiently use of raw materials, energy and water and, finally, to reduce toxic gases emissions.

## ACKNOWLEDGMENTS

The authors would like to thank the economic support given by CONACyT-SENER 245225 and to the project AM608 ININ. Technical support provided by Fidel Ramos, Miguel Duran, Miguel Hidalgo, Ivan Zuñiga, Osiel Hernandez, Karen Sánchez and Alfonso Romero, is also recognized.

## REFERENCES

- 1 M. F. De Volder, S. H. Tawfick, R. H. Baughman, A. J. Hart. *Science*. 339, 535 (2013).
- 2 T. Akasaka, F. Watari. *Acta biomaterialia*. 5, 607 (2009).
- 3 Z. Chen, L. Zhang, Y. Tang, Z. Jia. *Applied Surface Science*. 252, 2933 (2006).
- 4 Mochida, I., Kawabuchi, Y., Kawano, S., Matsumura, Y., & Yoshikawa, M. *Fuel*, 76(6), 543-548. (1997).
- 5 Zhao, P. Y., Zhang, J., Li, Q., & Wang, C. Y. *Journal of Power Sources*, 334, 170-178. (2016).
- 6 Daniel L. Schodek, P.Ferreira, M. F. Ashby, *Nanomaterials, Nanotechnologies and Design: An Introduction for Engineers and Architects*, edited by Butterworth-Heinemann. China, 2009, p. 560.
- 7 T. Masciangioli, W.X. Zhang. *Environmental science & technology*. 37, 102A (2003).
- 8 UNICEF and World Health Organization in Progress on sanitation and drinking water 2015, edited by A. Grojec 2015, p.80
- 9 G.A. Codd, L.F. Morrison, J.S. Metcalf. *Toxicology and applied pharmacology*, 203, 264 (2005).
- 10 W.W. Carmichael, G.L. Boyer. *Harmful Algae*, 54, 194 (2016).
- 11 Haisheng Chen, Yulong Ding, Toby Peters and Ferdinand Berger, Patent No. 2 643 742 (30 Ago 2007)
- 12 Yadav, A., Teja, A. K., & Verma, N. J. *Environ.Chem. Eng.*, 4(2), 1504-1513. (2016).
- 13 A. Srivastava, O. N. Srivastava, S. Talapatra, R. Vajtai, P. M.Ajayan. *Nat. Mater.* 3, 610 (2004).
- 14 S.P. Patole, P.S. Alegaonkar, H.C. Lee, J.B. Yoo. *Carbon*, 46, 1987 (2008).
- 15 A. S Brady-Estevez, S. Kang, M. Elimelech. *Small*, 4, 481 (2008).
- 16 C. D. Vecitis, M. H. Schnoor, M. S. Rahaman, J. D Schiffman, M. Elimelech. *Environmental science & technology*, 45, 3672 (2011).
- 17 S. T. Mostafavi, M. R. Mehrnia, A.M. Rashidi. *Desalination*, 238, 271 (2009).
- 18 H. Yan, G. Pan, H. Zou, X. Li, H. Chen. *Chinese Science Bulletin*, 49, 1694 (2004).
- 19 C.D. Vecitis, K.R. Zodrow, S. Kang, M. Elimelech. *ACS nano*, 4, 5471 (2010).
- 20 N. M. Mubarak, J. N. Sahu, E. C.Abdullah, N. S. Jayakumar. *Separation & Purification Reviews*. 43, 311 (2014).
- 21 M. S. Nasser, M. Khraisheh, M. A. Atieh. *Separation and Purification Technology*. 157, 141 (2016).
- 22 G. P. Rao, C. Lu, F. Su. *Separation and Purification Technology*, 58, 224 (2007).
- 23 X. Qu, P.J. Alvarez, Q. Li. *Water research*, 47, 3931 (2013).
- 24 V.K. Upadhyayula, S. Deng, M.C. Mitchell, G.B. Smith. *Science of the Total Environment*, 408, 1 (2009).

- 25 M. Mauter, M. Elimelech, *Environmental Science & Technology*, 42, 5843 (2008).
- 26 V. Thavasi, G. Singh, S. Ramakrishna. *Energy & Environmental Science*, 1, 205 (2008).
- 27 World Health Organization: Ambient (Outdoor) Air Quality and Health Fact sheet No. 313 (2014a).
- 28 I. Mochida, Y. Kawabuchi, S. Kawano, Y. Matsumura, M. Yoshikawa. *Fuel* 76, 543 (1997).
- 29 I.S. Yunus, Harwin, A. Kurniawan, D. Adityawarman, A. Indarto. *Environmental, Technology Reviews*, 1, 136 (2012).
- 30 R.Q. Long, R.T. Yang. *Amer. Chem. Soc.* 123, 2058 (2001).
- 31 R. Walawalkar, J. Apt, R. Mancini. *Energy Policy*, 5, 2558 (2007).
- 32 P. Denholm, T. Holloway. *Environmental Science & Technology*, 39, 9016 (2005).
- 33 U.S. Energy Information Administration, Report No. DOE/EIA-0484, 2016.
- 34 H. Ibrahim, A. Ilinca, J. Perron. *Renewable Sustainable Energy Rev.* 12, 1221 (2008).
- 35 K. Bilen, O. Ozyurt, K. Bakirci, S. Karsli, S. Erdogan, M. Yilmaz, O. ComakII. *Renewable Sustainable Energy Rev.* 12, 1529 (2008).
- 36 H. Chen, Y. Cong, W. Yang, C. Tan, Y. Li, Y. Ding. *Prog. Nat. Sci.* 19, 291 (2009).
- 37 L.G. Chen, J.L. Zheng, F.R. Sun. *Energy Convers Manage* 4, 2393 (2003).
- 38 M. Beaudin, H. Zareipour, A. Schellenberglabe, W. Rosehart. *Energy for Sustainable Development* 14, 302 (2010).
- 39 P. Aurelien, U. Husnu Emrah, K. Alokik, M. Steve, C. Manish. *Appl. Phys. Lett.* 87, 203511 (2005).
- 40 T. Matsumoto, T. Komatsu, K. Arai, T. Yamazaki, M. Kijima, H. Shimizu, J. Nakamura. *Chemical Communications*, 7, 840 (2004).
- 41 G.X. Wang, J.Ahn, J. Yao, M. Lindsay, H.K. Liu, S.X. Dou, Preparation and characterization of carbon nanotubes for energy storage, *Journal of Power Sources* 119–121 (2003) 16–23
- 42 H.Choi, S.Jung, J.Seo, D. Chang,L.Daic, J.Baek, Graphene for energy conversion and storage in fuel cells and supercapacitors, *Nano Energy* (2012) 1, 534–551
- 43 H. Zhan, J. Xiao, Z. Nie, X. Li, C. Wang, J. Zhang, J. Liu, *Current Opinion in Chem. Engineering*, 2, 151 (2013).
- 44 Q.Gao PhD Thesis, Optimizing carbon/carbon supercapacitors in aqueous and organic electrolytes, Université d'Orleans 2013 p38
- 45 A. Garcia, P. Miles, T. Centeno, J. Rojo. Uniaxially oriented carbon monoliths as supercapacitor electrodes, *Electrochemical Acta* 55 (2010) 8539-8544
- 46 A. Szczurek, G. Amaral, V. Fierro, A. Pizzi, A. Celzard, The use of tannin to prepare carbon gels. Part II. Carbon cryogels. *Carbon* 49 (2011) 2785-2794.
- 47 S. Candelaria, Y. Shao, W. Zhou, X. Li, J. Xiao, J.Zhang, Y. Wang, J. Liu, J. Li, G. Cao. *Nano Energy*, 1, 195 (2012).
- 48 E. Frackowiak, F. Beguin. *Carbon*, 40, 1775 (2002).
- 49 C. Du, N. Pan. *Nanotechnology Law & Business*, 569 (2007)
- 50 D. Cott, M. Verheijen, O. Richard, I. Radu, S. De Gendt, S.van Elshocht, P. Vereecken. *Carbon*, 58, 59 (2013).
- 51 J. Baker, *Energy Policy* 36, 4368 (2008).
- 52 Z.P. Huang, J.W. Xu, Z.F. Ren, J.H. Wang, M.P. Siegal, P.N. Provencio. *Applied physics letters*, 73, 3845 (1998).
- 53 A. Thess, R. Lee, P. Nikolaev, H. Dai. *Science*, 273, 483 (1996).
- 54 C. Journet, W.K. Maser, P. Bernier, A. Loiseau, M.L. De La Chapelle, D.L.S. Lefrant, J.E. Fischer. *Nature*, 388, 756 (1997).
- 55 M. Ishigami, J. Cumings, A. Zettl, S. Chen. *Chemical Physics Letters*, 319, 457 (2000).
- 56 H. Lange, M. Sioda, A. Huczko, Y. Zhu, H.W. Kroto, D.R.M. Walton. *Carbon*, 41, 1617 (2003).
- 57 R. Smajda, J.C. Andresen, M. Duchamp, R. Meunier, S. Casimirius, K. Hernadi, A. Magrez. *Physica status solidi (b)*, 246, 2457 (2009).

- 58 S.P. Patole, P.S. Alegaonkar, H.C. Lee, J.B. Yoo. *Carbon*, 46, 1987 (2008).
- 59 R. Kar, N.N. Patel, N. Chand, R.K. Shilpa, R.O. Dusane, D.S. Patil, S. Sinha. *Carbon*, 106, 233 (2016).
- 60 M.S. Bell, K.B. Teo, R.G. Lacerda, W.I. Milne, D.B. Hash, M. Meyyappan. *Pure and applied chemistry*, 78, 1117 (2006).
- 61 K. B. K. Teo, M. Chhowalla, G. A. J. Amaratunga, W. I. Milne, G. Pirio, P. Legagneux, F. Wyczisk, J. Olivier, D. Pribat. *J. Vac. Sci. Technol. B*, 20, 116 (2002).
- 62 N. Yusoff, N.H. Saad, M. Nabipoor, S. Sulaiman, D. Bien, C. Sheng. *Advanced Materials Research Journals*, 938, 58 (2013).
- 63 M.Pacheco, J. Pacheco, R. Valdivia in *Synthesis of Carbon Nanofibers by a Glow-arc Discharge*, edited by Ashok Kumar (INTECH Open Access Publisher, 2010), p. 438.
- 64 M.J. Pacheco, PhD. Thesis, Université Paul Sabatier, 2003.
- 65 H. Lange, A. Huczko, M. Sioda, M. Pacheco, M. Razafinimanana, A. Gleizes. *Plasma Chemistry and Plasma Processing*, 22, 523 (2002).
- 66 C. Du, N. Pan. *Journal of Power Sources*, 160, 1487 (2006).
- 67 C. Alvarado, Eng. Thesis, Universidad Nacional Autónoma de México, 2010.
- 68 T. Matsuura, K. Taniguchi, T. Watanabe. *Thin Solid Films*, 515, 4240 (2007).
- 69 A. Mansour, M. Razafinimanana, M. Monthieux, M. Pacheco, A. Gleizes. *Carbon*, 45, 1651 (2007).
- 70 M. Monthieux, M. Pacheco, H. Allouche, M. Razafinimanana, N. Caprais, L. Donnadieu, A. Gleizes. *American Institute of Physics Conference Proceedings*, 633, 182 (2002).
- 71 N. Estrada, PhD. Thesis, Instituto Tecnológico de Toluca, 2011.
- 72 J.A. Juanico, MSc. Thesis, Universidad Autónoma Metropolitana, 2004.
- 73 J.Y. Lee, H.L. Lee, S. Kim. *Materials Science Forum*, 475, 2463 (2005).
- 74 C.H. Wu. *Journal of Hazardous Materials*, 144, 93 (2007).
- 75 R. García, Lic. Thesis, Instituto Tecnológico de Toluca, (2011)
- 76 E. Frackowiak, F. Beguin,. *Carbon*, 39, 937 (2001)