

A new method of passive modifications for partial frequency assignment of general structures

Roberto Belotti¹, Huajiang Ouyang², Dario Richiedei^{1*}

¹Dipartimento di Tecnica e Gestione dei Sistemi Industriali,

Università degli Studi di Padova, Stradella S. Nicola 3, Vicenza 36100, Italy

²School of Engineering, University of Liverpool, the Quadrangle, L69 3GH, Liverpool, U.K.

ABSTRACT.

The assignment of a subset of natural frequencies to vibrating systems can be conveniently achieved by means of suitable structural modifications. It has been observed that such an approach usually leads to the undesired change of the unassigned natural frequencies, which is a phenomenon known as frequency spill-over. Such an issue has been dealt with in the literature only in simple specific cases.

In this paper, a new and general method is proposed that aims to assign a subset of natural frequencies with low spill-over. The optimal structural modifications are determined through a three-step procedure that considers both the prescribed eigenvalues and the feasibility constraints, assuring that the obtained solution is physically realizable. The proposed method is therefore applicable to very general vibrating systems, such as those obtained through the finite element method.

The numerical difficulties that may occur as a result of employing the method are also carefully addressed. Finally, the capabilities of the method are validated in three test-cases in which both lumped and distributed parameters are modified to obtain the desired eigenvalues.

KEYWORDS. Structural modification; passive control; partial eigenvalue assignment; spill-over.

1. Introduction

The assignment of natural frequencies (i.e. eigenvalues) is an important problem related to the design of vibrating systems. For example, in many applications it is wanted to keep the natural frequencies of the system far away from the dominant components of the harmonic excitation force, preventing resonance that can lead to structural failure. In contrast, in other cases, e.g. the design of resonators, it is wanted that a natural frequency of the system matches the single-harmonic excitation, in order to improve the performance of the machine and, at the same time, minimize the excitation effort.

It is well known that the natural frequencies are associated with the system eigenvalues, namely the solutions of the characteristic equation $\det(\lambda\mathbf{M} - \mathbf{K}) = 0$, given the mass matrix \mathbf{M} and the stiffness matrix \mathbf{K} . Therefore, the appropriate mathematical framework for the assignment of natural frequencies is certainly constituted by the solution of inverse eigenvalue problems. Such problems concern the specification of the desired eigenvalues of the system and the determination of the suitable modifications of the system matrices that result in the required change of eigenvalues. Both passive [1, 2, 3] and active [4, 5, 6] approaches can be used to achieve such a goal, depending on the employed way of modifying the system matrices. In fact, the passive approaches consist in the structural modification, namely the adjustment of the physical parameters of the system, whereas the active approaches rely on feedback control through actuators and sensors. In the present paper, the assignment of natural frequencies through structural modification is addressed, which is a widely-employed approach that stands out for the low cost of implementation and the inherent stability of the resulting system.

* Corresponding author.

email address: dario.richiedei@unipd.it (Dario Richiedei)

The most useful case of natural frequency assignment is the one in which only a few eigenvalues are prescribed, because in practice often there is just a small number of dominant eigenvalues that characterize the dynamic behaviour. The modification of a subset of the natural frequencies, however, can lead to undesired change of the remaining ones, which is a phenomenon known as frequency spill-over. Design methods that prevent spill-over can avoid unexpected dynamics associated with the unassigned modes. In fact, the assignment of a subset of natural frequencies without spill-over, known in the literature as *partial eigenvalue assignment*, has become popular in very recent years. Active and passive approaches, however, tackle spill-over in a very different way. Indeed, in active control spill-over can make certain eigenvalues to become unstable, whereas passive modifications always maintain stability, as long as positive (semi-)definiteness of the system matrices are preserved. Nevertheless, even if instability is avoided, prevention of spill-over is desirable, to inhibit undesired resonances.

In active control, spill-over can be easily avoided, which can be manifested by the necessary and sufficient conditions available in the literature that ensure that the unassigned eigenvalues are kept unchanged. The earliest techniques for partial eigenvalue assignment rely on first order models, such as the projection and deflation technique [7] by Saad, or the parametric solution [8] by Datta and Sarkissian. Second order models are certainly more convenient since some properties of the system matrices, such as symmetry and sparsity, can be exploited. The discovery of orthogonality relations for the eigenvectors of the quadratic model by Datta et al. [5] stimulated the development of parametric solutions of the partial eigenvalue assignment problem [9, 10]. The increasing complexity of the controlled vibrating systems determined the success of methods based on receptances, which can be experimentally measured, so they can be used even without complete knowledge of the system matrices. Indeed, partial eigenvalue assignment using receptances is achieved by Ghandchi Tehrani et al. in [11]. In [12], Singh et al. proposed a receptance-based method aimed at control of aerospace vehicles, which allowed for the placement of the poles due to aeroelasticity while ensuring the actuator poles remained invariant. Recently, a computationally efficient formulation was proposed by Bai and Wan in [13], by employing both receptances and system matrices, that led to the solution of a small-size linear system. A similar “hybrid” approach was proposed by Ram et al. to control a system with time-delay in [14], which was later extended to multi-input systems by Bai et al. in [15]. Partial eigenvalue assignment without spill-over for systems with time-delay has been addressed also by Singh et al. in [16]. Another relevant issue is robust control, which is studied in several papers about partial eigenvalue assignment [17, 18, 19, 20, 21]. It is worth to mention also the no spill-over condition for mass and stiffness modifications introduced by Zhang et al. in [22], which does not require the knowledge of the vibration modes to be retained.

The latter condition, however, cannot be trivially extended to passive approaches, because structural modifications must have a specified matrix structure to be feasible. Ensuring feasibility of the system matrices is always a challenge, even if all the eigenvalues are assigned and then spill-over is not an issue. Cai and Xu, for example, managed to preserve non-singularity or positive definiteness of the mass matrix [23]. Using a similar approach, Cai et al. in [24] dealt with the assignment of an incomplete set of eigenvalues, even though spill-over was not explicitly addressed. In [25], Mao and Dai propose a method for partial eigenvalue assignment for gyroscopic systems which preserved the mathematical structure but lost the physical realizability.

Available passive methods that ensure feasible solutions usually address only very simple specific problems. For example, Gürgöze and İnceoğlu in [26] considered the determination of the suitable spring to preserve the fundamental frequency of a beam with an added mass. Similarly, Mermertaş and Gürgöze [27] studied attachment of point masses and springs to plates keeping the fundamental frequency unchanged. In [28] Çakar examined the preservation of one natural frequency of a structure, neutralizing the shift of such a frequency caused by the addition of a number of masses through a suitable grounded spring. The partial eigenvalue assignment problem for general mass-spring structures, instead, was tackled by Ouyang and Zhang in [29], in

which two methods were proposed: the first one concerned simply connected in-line mass-spring systems, while the second one dealt with multiple-connected mass-spring systems.

To overcome these limitations of known investigations reported in the open literature, the method proposed in this paper intends to extend the one in [29] to general vibrating linear systems with arbitrary matrix structures and modifiable parameters (e.g. distributed ones), such as those obtained with finite element modelling. The method of the cited paper exploits the mass-normalised stiffness matrix, which has the disadvantage that the physical parameters of the system cannot always be reconstructed, with few exceptions including the case in which the mass matrix is diagonal. In contrast, the proposed method deals with the mass matrix and the stiffness matrix separately, hence it is applicable to a wider class of vibrating systems.

Frequency assignment will be achieved in three steps: first of all, a system model that has the desired eigenvalues is sought, regardless of the constraints of physical feasibility. After that, an equivalent system is computed, which minimizes the deviation of the modifications from satisfying the feasibility constraints, by integration of a matrix differential equation. Finally, if it is necessary, the system is projected onto the feasibility constraints to obtain an optimal physically realizable structure.

The proposed method is validated in three different test-cases. First of all, a simple distributed-parameter system is employed to show the capabilities of the method in dealing with mass and stiffness matrices obtained from finite element modelling. Then the method is tested with a lumped parameter system, in order to provide a comparison with the state-of-the-art. Finally, the method is challenged with the modification of a lumped-and-distributed parameter model of a vibrating system of industrial interest.

The paper is organized as follows. In Section 2 the method is described in detail and the difficulties related to the numerical solution of the problem are examined. In Section 3, the numerical assessment of the proposed method is carried out. Finally, in Section 4 the conclusions are drawn.

2. Method description

2.1. Method overview

Let us consider a linear, time-invariant, n -degree of freedom undamped vibrating system and suppose that it is represented by symmetric positive-definite mass matrix $\mathbf{M}_0 \in \mathbb{R}^{n \times n}$ and symmetric positive-semidefinite stiffness matrix $\mathbf{K}_0 \in \mathbb{R}^{n \times n}$. The system will be denoted henceforth as the pair $(\mathbf{M}_0, \mathbf{K}_0)$. Let us denote the n system eigenvalues by $\lambda_1, \lambda_2, \dots, \lambda_n$. It is wanted that a subset of $p < n$ critical eigenvalues, which are without loss of generality $\lambda_1, \lambda_2, \dots, \lambda_p$, is replaced by the set $\mu_1, \mu_2, \dots, \mu_p$ through suitable system modifications, under the assumption that $\{\lambda_1, \dots, \lambda_p\} \cap \{\lambda_{p+1}, \dots, \lambda_n\} = \emptyset$ and $\{\mu_1, \dots, \mu_p\} \cap \{\lambda_{p+1}, \dots, \lambda_n\} = \emptyset$. The other $n - p$ eigenvalues should be left unchanged, if possible, or at least the shift of such eigenvalues should be kept to a minimum. It is also required that such modifications are feasible, i.e., the resulting matrices are physically meaningful.

In order to achieve such a result, the method proposed in this work relies on a three-step scheme, which generalizes the one proposed in [29]. First of all, a system $(\mathbf{M}_s, \mathbf{K}_s)$ is sought that realises the desired eigenvalues without taking into account the physical constraints, by taking advantage of the method proposed in [30]. The second step, instead, consists in the search for a system $(\mathbf{M}_\infty, \mathbf{K}_\infty)$, belonging to the space of systems that have the same eigenvalues as $(\mathbf{M}_s, \mathbf{K}_s)$, such that it is as close as possible to the space of feasible systems.

In practice, the second step is performed by exploiting a class of matrix differential equations, which are known as isospectral flows [29, 31, 32] for the remarkable property of preserving eigenvalues. Finally, the feasible system that provides the best approximation of the desired eigenvalues is computed as the orthogonal projection of $(\mathbf{M}_\infty, \mathbf{K}_\infty)$ onto the space of feasible systems. Figure 1 schematically represents the proposed method. This Section gives a detailed explanation of the three stages that constitutes the method.

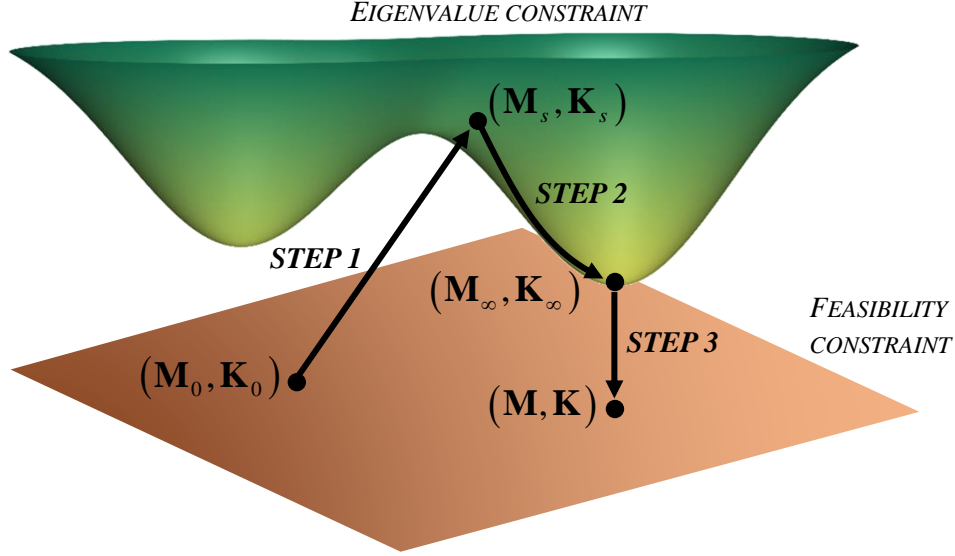

Figure 1. Graphical method description

2.2. Direct updating of the system

The first step relies on the method proposed by Yang et al. in [30], thus it will be only briefly explained here. The interested reader is suggested to read the original paper for more details.

In order to perform the first step, the knowledge of the eigenvectors $\mathbf{u}_1, \dots, \mathbf{u}_p$, corresponding to the eigenvalues to be modified $\lambda_1, \dots, \lambda_p$, is required. It is supposed, without loss of generality, that the eigenvectors are mass normalised, i.e. $\mathbf{u}_i^T \mathbf{M}_0 \mathbf{u}_i = 1$, for $i = 1, \dots, p$. It is wanted to find a new system $(\mathbf{M}_s, \mathbf{K}_s)$ that possesses the same eigenvalues as $(\mathbf{M}_0, \mathbf{K}_0)$, except for $\lambda_1, \dots, \lambda_p$ which are replaced with new eigenvalues, i.e. μ_1, \dots, μ_p , respectively. Such an objective can be conveniently expressed in matrix form. Let us define

$$\begin{aligned} \Lambda_1 &= \text{diag}(\lambda_1, \dots, \lambda_p) \\ \Sigma_1 &= \text{diag}(\mu_1, \dots, \mu_p) \\ \mathbf{U}_1 &= [\mathbf{u}_1, \dots, \mathbf{u}_p]. \end{aligned} \tag{1}$$

The following two conditions are wanted to be satisfied:

- a) a condition to impose the new eigenvalues:

$$(\mathbf{M}_0 + \Delta \mathbf{M}) \mathbf{U}_1 \Sigma_1 = (\mathbf{K}_0 + \Delta \mathbf{K}) \mathbf{U}_1 \tag{2}$$

b) a condition that assures that spill-over does not take place while assigning the desired eigenvalues with Eq. (2).

Condition a) actually implies that, in this intermediate step, eigenvalues are modified without changing the corresponding eigenvectors, namely if $\Delta\mathbf{M}$ and $\Delta\mathbf{K}$ satisfy (2), then $[\mu_i(\mathbf{M}_0 + \Delta\mathbf{M}) - (\mathbf{K}_0 + \Delta\mathbf{K})]\mathbf{u}_i = 0$, for $i = 1, \dots, p$. Theoretically, any other choice of eigenvectors could be made, but in this way it has been observed that the required modification matrices are usually smaller in magnitude (with respect to the Frobenius norm).

In [22] it has been proved that, under the abovementioned assumptions, the following equation can be used to represent condition b), by just requiring the knowledge of the eigenvalues to be modified (collected in Λ_1) and their associated eigenvectors (collected in \mathbf{U}_1):

$$\Delta\mathbf{K}(\mathbf{M}_0^{-1} - \mathbf{U}_1\mathbf{U}_1^T) - \Delta\mathbf{M}(\mathbf{M}_0^{-1}\mathbf{K}_0\mathbf{M}_0^{-1} - \mathbf{U}_1\Lambda_1\mathbf{U}_1^T) = \mathbf{0}. \quad (3)$$

The modification matrices $\Delta\mathbf{M}$ and $\Delta\mathbf{K}$ that satisfy the latter equation are assured to leave the eigenvalues $\lambda_{p+1}, \dots, \lambda_n$ unchanged.

Although \mathbf{M}_0 is invertible, its explicit inversion is not recommended, due to the computational cost. Hence, the formulation of Eq. (3) is not numerically efficient. In order to avoid the inversion of mass matrix \mathbf{M}_0^{-1} , in [30] it is also suggested to express the modification matrices as

$$\begin{aligned} \Delta\mathbf{M} &= \mathbf{M}_0\boldsymbol{\Psi}\mathbf{M}_0 \\ \Delta\mathbf{K} &= \mathbf{M}_0\boldsymbol{\Phi}\mathbf{M}_0 \end{aligned} \quad (4)$$

where $\boldsymbol{\Psi}, \boldsymbol{\Phi} \in \mathbb{R}^{n \times n}$ are real symmetric matrices. It is straightforward to prove that the two equations (2) and (3) are equivalent to

$$\begin{aligned} (\mathbf{M}_0 + \mathbf{M}_0\boldsymbol{\Psi}\mathbf{M}_0)\mathbf{U}_1\boldsymbol{\Sigma}_1 &= (\mathbf{K}_0 + \mathbf{M}_0\boldsymbol{\Phi}\mathbf{M}_0)\mathbf{U}_1 \\ \boldsymbol{\Phi}(\mathbf{M}_0 - \mathbf{M}_0\mathbf{U}_1\mathbf{U}_1^T\mathbf{M}_0) - \boldsymbol{\Psi}(\mathbf{K}_0 - \mathbf{M}_0\mathbf{U}_1\Lambda_1\mathbf{U}_1^T\mathbf{M}_0) &= \mathbf{0}, \end{aligned} \quad (5)$$

in which the inverse \mathbf{M}_0^{-1} is not involved. It is recommendable to solve such equations for the optimal $\boldsymbol{\Phi}$ and $\boldsymbol{\Psi}$ in a least-square sense. In particular, it is suggested to solve the following optimization problem:

$$\begin{aligned} \min_{\boldsymbol{\Phi}, \boldsymbol{\Psi}} & \|(\mathbf{M}_0 + \mathbf{M}_0\boldsymbol{\Psi}\mathbf{M}_0)\mathbf{U}_1\boldsymbol{\Sigma}_1 - (\mathbf{K}_0 + \mathbf{M}_0\boldsymbol{\Phi}\mathbf{M}_0)\mathbf{U}_1\|_F^2 \\ \text{subject to} & \boldsymbol{\Phi}(\mathbf{M}_0 - \mathbf{M}_0\mathbf{U}_1\mathbf{U}_1^T\mathbf{M}_0) - \boldsymbol{\Psi}(\mathbf{K}_0 - \mathbf{M}_0\mathbf{U}_1\Lambda_1\mathbf{U}_1^T\mathbf{M}_0) = \mathbf{0}, \end{aligned} \quad (6)$$

where subscript F indicates the Frobenius norm. Given the convexity of the proposed formulation, it is possible to find a numerical solution with moderately low effort. In fact, convex optimization is a well understood topic in numerical computation and is solved through effective and efficient numerical algorithms available in many software packages. Supposed that $\hat{\boldsymbol{\Phi}}$ and $\hat{\boldsymbol{\Psi}}$ are the optimal solution of problem (6), then the modified system matrices can be obtained as

$$\begin{aligned} \mathbf{M}_s &= \mathbf{M}_0 + \mathbf{M}_0\hat{\boldsymbol{\Psi}}\mathbf{M}_0 \\ \mathbf{K}_s &= \mathbf{K}_0 + \mathbf{M}_0\hat{\boldsymbol{\Phi}}\mathbf{M}_0. \end{aligned} \quad (7)$$

An important issue is that the mass and stiffness matrices should be positive definite and positive semidefinite, respectively. The numerical validation of the method showed that the obtained matrices comply with the positive definite constraint, without explicitly requiring so. If it is necessary, it is possible to exploit one of the popular algorithms for semidefinite optimization which can take into account constraints on the positive definiteness of the matrices. Examples of software that implements such algorithms are Mosek [33], SeDuMi [34] and SDPT3 [35]. For the sake of efficiency, however, semidefinite constraint should be imposed only if the optimization of (6) fails.

2.3. Isospectral flow

The system $(\mathbf{M}_s, \mathbf{K}_s)$ obtained in the first step meets the requirements regarding the eigenvalues but it does not always correspond to a physically meaningful system. In fact, matrices \mathbf{M}_s and \mathbf{K}_s are usually dense and unstructured matrices. Such an issue is overcome in the second step. In practice, a feasible system (\mathbf{M}, \mathbf{K}) is sought which has the same eigenvalues as $(\mathbf{M}_s, \mathbf{K}_s)$. Namely, it is wanted that (\mathbf{M}, \mathbf{K}) belongs to the space \mathcal{V} of the feasible systems and also to the space below

$$\mathcal{M}(\mathbf{M}_s, \mathbf{K}_s) = \left\{ (\mathbf{P}^T \mathbf{M}_s \mathbf{P}, \mathbf{P}^T \mathbf{K}_s \mathbf{P}), \text{ for arbitrary } \mathbf{P} \text{ s.t. } \det(\mathbf{P}) \neq 0 \right\} \subseteq \mathbb{R}^{n \times n} \times \mathbb{R}^{n \times n}. \quad (8)$$

It is important to remark that all the systems belonging to $\mathcal{M}(\mathbf{M}_s, \mathbf{K}_s)$ have the same eigenvalues. However, the eigenvectors are often different. Such a circumstance is not concerning, because eigenvector assignment is not addressed in the present paper.

The definition of \mathcal{V} requires knowledge of the system design and it depends on the physical parameters that can be reasonably modified. If it is supposed that the mass and stiffness modification matrices depend linearly on the modifiable parameters, namely that they are linear combinations of the linear independent matrices

$\{\mathbf{M}_1, \dots, \mathbf{M}_{n_M}\}$ and $\{\mathbf{K}_1, \dots, \mathbf{K}_{n_K}\}$, respectively, then the space $\mathcal{V} \subseteq \mathbb{R}^{n \times n} \times \mathbb{R}^{n \times n}$ can be defined as follows:

$$\mathcal{V} = \left\{ (\mathbf{M}, \mathbf{K}) : \mathbf{M} = \mathbf{M}_0 + \sum_{i=1}^{n_M} x_i \mathbf{M}_i, \mathbf{K} = \mathbf{K}_0 + \sum_{i=1}^{n_K} y_i \mathbf{K}_i \text{ for some scalar coefficients } x_i \text{ and } y_i \right\}, \quad (9)$$

where n_M and n_K are, respectively, the numbers of mass matrix elements and stiffness matrix elements that can be modified. Such an assumption is made in many other works about structural modifications (e.g. [36]) since it allows representing most types of modifications, so it does not invalidate the generality of the method. The matrices \mathbf{M}_i and \mathbf{K}_i represent the topology of the contribution of each modifiable parameter, while the coefficients x_i and y_i represent the magnitude of the modification. It is reasonable to choose the matrices of the basis of \mathcal{V} (i.e. \mathbf{M}_i and \mathbf{K}_i) in such a way that the associated coefficients represent meaningful quantities.

Alternatively, the choice of basis can be exploited to improve the numerical computations, which will be detailed in Section 2.4.

From a geometrical point of view, the search of a system that complies with both the constraints on the natural frequencies and the feasibility constraints is equivalent to the search of the intersection of $\mathcal{M}(\mathbf{M}_s, \mathbf{K}_s)$ and \mathcal{V} . If such an intersection is empty, it is still interesting to find the system that minimizes the distance between such spaces, because it could be interpreted as a least-squares solution of the optimal design problem. According to the tests that have been carried out, this approach is preferred to the simple projection of $(\mathbf{M}_s, \mathbf{K}_s)$ onto space \mathcal{V} , because the latter way can be affected by non-negligible spill-over.

In order to explain the proposed solution, let us define the projection $\mathcal{P} : \mathbb{R}^{n \times n} \times \mathbb{R}^{n \times n} \rightarrow \mathcal{V}$ of a generic system (\mathbf{X}, \mathbf{Y}) as

$$\mathcal{P}(\mathbf{X}, \mathbf{Y}) = (\mathcal{P}_1(\mathbf{X}), \mathcal{P}_2(\mathbf{Y})), \quad (10)$$

where \mathcal{P}_1 and \mathcal{P}_2 are the orthogonal projection of the mass matrix \mathbf{X} and stiffness matrix \mathbf{Y} , respectively. The computation of the projection is very straightforward, if the matrices are treated as vectors. As an example, the algorithm for the projection \mathcal{P}_1 of the mass matrix is described below. It is wanted to find the coefficients x_1, \dots, x_{n_M} such that

$$\mathcal{P}_1(\mathbf{X}) = \mathbf{M}_0 + x_1 \mathbf{M}_1 + \dots + x_{n_M} \mathbf{M}_{n_M} \quad (11)$$

Let us denote $\text{vec}(\cdot)$ the operator that stacks the columns of a matrix one below the other. For convenience it is also defined

$$\begin{aligned} \mathbf{S}_M &= [\text{vec}(\mathbf{M}_1) \dots \text{vec}(\mathbf{M}_{n_M})] \\ \boldsymbol{\delta m} &= \text{vec}(\mathbf{X} - \mathbf{M}_0). \end{aligned} \quad (12)$$

By exploiting the orthogonality of the least-squares residual to the range of \mathbf{S}_M , the appropriate coefficients in (11) are computed by solving the following problem:

$$\min_{\mathbf{x}} \|\mathbf{S}_M \mathbf{x} - \boldsymbol{\delta m}\|_2^2 \quad (13)$$

where $\mathbf{x} = (x_1, \dots, x_{n_M})^T$. Let $\hat{\mathbf{x}}$ be the least-squares solution, which can be analytically computed as

$$\hat{\mathbf{x}} = (\mathbf{S}_M^T \mathbf{S}_M)^{-1} \mathbf{S}_M^T \boldsymbol{\delta m}, \quad (14)$$

then, the projection of the mass matrix \mathbf{X} is

$$\mathcal{P}_1(\mathbf{X}) = \mathbf{M}_0 + \text{vec}^{-1}(\mathbf{S}_M \hat{\mathbf{x}}). \quad (15)$$

The definition of \mathcal{P}_2 is analogous and thus it is omitted.

The projection onto \mathcal{V} is the tool that expresses the distance from a general system $(\mathbf{X}, \mathbf{Y}) \in \mathcal{M}(\mathbf{M}_s, \mathbf{K}_s)$ to space \mathcal{V} . It is worth to remark that, given the definition (8), any system in $\mathcal{M}(\mathbf{M}_s, \mathbf{K}_s)$ is uniquely determined by an invertible matrix \mathbf{P} , hence the distance function is dependent on \mathbf{P} . For clarity of notation, it is defined

$$\begin{aligned} \gamma_1(\mathbf{P}) &= \mathbf{P}^T \mathbf{M}_s \mathbf{P} - \mathcal{P}_1(\mathbf{P}^T \mathbf{M}_s \mathbf{P}) \\ \gamma_2(\mathbf{P}) &= \mathbf{P}^T \mathbf{K}_s \mathbf{P} - \mathcal{P}_2(\mathbf{P}^T \mathbf{K}_s \mathbf{P}). \end{aligned} \quad (16)$$

Hence, the distance function F is expressed by

$$F(\mathbf{P}) = \frac{1}{2} \left(\|\gamma_1(\mathbf{P})\|_F^2 + \|\gamma_2(\mathbf{P})\|_F^2 \right). \quad (17)$$

Such a function has been also proposed in [37] to solve the inverse eigenvalue problem for linear pencils. The function in Eq. (17) is minimized by integrating the so-called descent flow, which is the following matrix differential equation

$$\begin{cases} \dot{\mathbf{P}}(t) = -\nabla F(\mathbf{P}(t)) \\ \mathbf{P}(0) = \mathbf{I}, \end{cases} \quad (18)$$

where \mathbf{I} is the identity matrix. Such a differential equation induces the desired isospectral flow on $\mathcal{M}(\mathbf{M}_s, \mathbf{K}_s)$, which is defined simply by

$$\begin{aligned} \mathbf{M}(t) &= \mathbf{P}(t)^T \mathbf{M}_s \mathbf{P}(t) \\ \mathbf{K}(t) &= \mathbf{P}(t)^T \mathbf{K}_s \mathbf{P}(t). \end{aligned} \quad (19)$$

As proved in [37], a closed form for the gradient of F exists, which is particularly useful for numerical computations:

$$\nabla F(\mathbf{P}) = 2(\mathbf{M}_s \mathbf{P} \gamma_1(\mathbf{P}) + \mathbf{K}_s \mathbf{P} \gamma_2(\mathbf{P})). \quad (20)$$

A remarkable property of the descent flow is that its solution $\mathbf{P}(t)$ asymptotically converges. Thus, defining $\mathbf{P}_\infty = \lim_{t \rightarrow +\infty} \mathbf{P}(t)$, the system that locally minimizes the distance to \mathcal{V} is

$$\begin{aligned} \mathbf{M}_\infty &= \mathbf{P}_\infty^T \mathbf{M}_s \mathbf{P}_\infty \\ \mathbf{K}_\infty &= \mathbf{P}_\infty^T \mathbf{K}_s \mathbf{P}_\infty. \end{aligned} \quad (21)$$

If $(\mathbf{M}_\infty, \mathbf{K}_\infty)$ belongs to \mathcal{V} , then a system that satisfies both the feasibility constraint and the eigenvalue constraint has been found. Otherwise, a third step is required, which is the projection of $(\mathbf{M}_\infty, \mathbf{K}_\infty)$ onto \mathcal{V} . In practice, it is defined:

$$\begin{aligned} \mathbf{M} &= \mathcal{P}_1(\mathbf{M}_\infty) \\ \mathbf{K} &= \mathcal{P}_2(\mathbf{K}_\infty). \end{aligned} \quad (22)$$

The system (\mathbf{M}, \mathbf{K}) computed by means of the described procedure actually corresponds to a physically meaningful system, and it has low spill-over, as proven in Section 3 where different tests are shown.

In practical design applications, it is recommendable to introduce constraints on the coefficients x_i and y_i that appear in the definition (9) to represent technical constraints. Collecting the coefficients into vectors

$\mathbf{x} = (x_1, \dots, x_{n_M})^T$ and $\mathbf{y} = (y_1, \dots, y_{n_K})^T$, the constraint sets

$$\begin{aligned} \Gamma_M &= \{ \mathbf{x} \in \mathbb{R}^{n_M} : \mathbf{A}_M \mathbf{x} \leq \mathbf{b}_M, \mathbf{A}_{M,\text{eq}} \mathbf{x} = \mathbf{b}_{M,\text{eq}}, \mathbf{x}_L \leq \mathbf{x} \leq \mathbf{x}_U \} \\ \Gamma_K &= \{ \mathbf{y} \in \mathbb{R}^{n_K} : \mathbf{A}_K \mathbf{y} \leq \mathbf{b}_K, \mathbf{A}_{K,\text{eq}} \mathbf{y} = \mathbf{b}_{K,\text{eq}}, \mathbf{y}_L \leq \mathbf{y} \leq \mathbf{y}_U \} \end{aligned} \quad (23)$$

define a convex polytope and box constraints, for some appropriate matrices \mathbf{A}_M , $\mathbf{A}_{M,\text{eq}}$, \mathbf{A}_K , $\mathbf{A}_{K,\text{eq}}$ and vectors \mathbf{b}_M , $\mathbf{b}_{M,\text{eq}}$, \mathbf{x}_L , \mathbf{x}_U , \mathbf{b}_K , $\mathbf{b}_{K,\text{eq}}$, \mathbf{y}_L , \mathbf{y}_U . Hence, the constrained feasible space $\hat{\mathcal{V}}$ is introduced and defined as:

$$\hat{\mathcal{V}} = \left\{ (\mathbf{M}, \mathbf{K}) : \mathbf{M} = \mathbf{M}_0 + \sum_{i=1}^{n_M} x_i \mathbf{M}_i, \mathbf{K} = \mathbf{K}_0 + \sum_{i=1}^{n_K} y_i \mathbf{K}_i, \mathbf{x} \in \Gamma_M, \mathbf{y} \in \Gamma_K \right\}. \quad (24)$$

The projection onto $\hat{\mathcal{V}}$ can be computed similarly to the projection onto \mathcal{V} described in the previous Section, except for the fact that the unconstrained least-squares problem (13) must be replaced with a constrained least-squares problem. This subtle difference is actually very relevant from the numerical point of view, since the presence of constraints requires ad-hoc numerical algorithms, rather than analytical computation.

2.4. Numerical issues

The description of the proposed method is concluded in this final sub-section in which some numerical issues are addressed. In particular, a scaling strategy is explained which can improve the projection onto the constrained space $\hat{\mathcal{V}}$ and also the numerical integration of (18).

Indeed, the numerical validation of the method reveals that the proposed procedure can be affected by computational issues. As a matter of fact, quantities that are very different in magnitude from each other are involved in differential equation (18) and in the feasibility space (24). In particular, this means ODE (18) is stiff, thus increasing considerably the CPU time, and it also exacerbates the errors in the computation of the projection onto the constrained feasible subspace $\hat{\mathcal{V}}$. Both these issues can be overcome by recasting the problem as a scaled equivalent problem. Scaling is aimed at formulating the problem with dimensionless unknowns, to improve numerical conditioning [38, 39, 40].

Two scaling strategies are employed, each one aimed at solving a specific numerical issue. The first one, which deals with the integration of ODE (18), requires the modification of the spaces $\mathcal{M}(\mathbf{M}_s, \mathbf{K}_s)$ and $\hat{\mathcal{V}}$. The second one, instead, deals with the projection onto $\hat{\mathcal{V}}$ and it can be thought as a change of basis. However, both strategies must be implemented carefully to ensure that the scaled problem is equivalent to the original one.

First of all, it is wanted that the orders of magnitudes of the mass and stiffness matrices are approximately the same. Therefore, given the scaling factors $\alpha > 0$ and $\beta > 0$, the space $\mathcal{M}(\mathbf{M}_s, \mathbf{K}_s)$ is replaced by the scaled space $\mathcal{M}(\tilde{\mathbf{M}}_s, \tilde{\mathbf{K}}_s)$, where

$$\begin{aligned} \tilde{\mathbf{M}}_s &= \alpha \mathbf{M}_s \\ \tilde{\mathbf{K}}_s &= \beta \mathbf{K}_s. \end{aligned} \quad (25)$$

Such a choice is motivated by the fact that the same scaling strategy has been proved to be successful in improving the reliability of the numerical solution of quadratic eigenvalue problems [38, 39]. In the cited references, the determination of the optimal scaling factors is addressed. Although a comprehensive analysis of this issue would be outside the scope of the paper, the numerical tests carried out clearly show that choosing α and β roughly as the inverse of the norms of \mathbf{M}_s and \mathbf{K}_s , respectively, in such a way that the norms of $\tilde{\mathbf{M}}_s$ and $\tilde{\mathbf{K}}_s$ are both approximately equal to 1, is often a satisfactory choice.

Additionally, the space of feasible systems $\hat{\mathcal{V}}$ is replaced by:

$$\tilde{\mathcal{V}} = \left\{ (\mathbf{M}, \mathbf{K}) : \mathbf{M} = \alpha \left(\mathbf{M}_0 + \sum_{i=1}^{n_M} x_i \mathbf{M}_i \right), \mathbf{K} = \beta \left(\mathbf{K}_0 + \sum_{i=1}^{n_K} y_i \mathbf{K}_i \right), \mathbf{x} \in \Gamma_M, \mathbf{y} \in \Gamma_K \right\}. \quad (26.a)$$

The second issue is that coefficients x_i can be very different in magnitude from each other, and so are y_i , especially when both lumped and distributed parameters are considered at the same time. In order to improve the computation of the projections onto the feasibility space, it is convenient to compensate for the different magnitudes with an appropriate scaling. In fact, given non-zero scalars $\eta_1, \dots, \eta_{n_M}$ and $\tau_1, \dots, \tau_{n_K}$, it is defined

$$\tilde{\mathcal{V}} = \left\{ (\mathbf{M}, \mathbf{K}) : \mathbf{M} = \alpha \left(\mathbf{M}_0 + \sum_{i=1}^{n_M} \tilde{x}_i \eta_i \mathbf{M}_i \right), \mathbf{K} = \beta \left(\mathbf{K}_0 + \sum_{i=1}^{n_K} \tilde{y}_i \tau_i \mathbf{K}_i \right), \tilde{\mathbf{x}} \in \tilde{\Gamma}_M, \tilde{\mathbf{y}} \in \tilde{\Gamma}_K \right\}, \quad (26.b)$$

where the constraint sets are suitably adjusted to take the scaling into account. Such an adjustment is straightforward. For example, a convex polytope $\mathbf{A}_M \mathbf{x} \leq \mathbf{b}_M$ in the definition of Γ_M should be replaced with $\mathbf{A}_M \text{diag}(\eta_i) \tilde{\mathbf{x}} \leq \mathbf{b}_M$ in the definition of $\tilde{\Gamma}_M$. The other constraints require similar modifications and hence are not detailed. It is evident that the two definitions of $\tilde{\mathcal{V}}$ only differ in the scale of the parameters, i.e. \mathbf{x}, \mathbf{y} in (26.a) and $\tilde{\mathbf{x}}, \tilde{\mathbf{y}}$ in (26.b).

The fundamental property of the proposed scaling procedure is that the resulting scaled problem is equivalent to the original one. In fact, let us suppose that \mathbf{P} is such that $(\mathbf{P}^T \tilde{\mathbf{M}}_s \mathbf{P}, \mathbf{P}^T \tilde{\mathbf{K}}_s \mathbf{P}) \in \tilde{\mathcal{V}}$, then there exist coefficients $(\tilde{x}_1, \dots, \tilde{x}_{n_M}) \in \tilde{\Gamma}_M$ such that

$$\mathbf{P}^T \tilde{\mathbf{M}}_s \mathbf{P} = \alpha \left(\mathbf{M}_0 + \sum_{i=1}^{n_M} \tilde{x}_i \eta_i \mathbf{M}_i \right). \quad (27)$$

Dividing both sides of the equation by α , it is readily obtained that $\mathbf{P}^T \mathbf{M}_s \mathbf{P} = \mathbf{M}_0 + \sum_{i=1}^{n_M} x_i \mathbf{M}_i$, with $x_i = \tilde{x}_i \eta_i$ for $i=1, \dots, n_M$. Moreover, if $\tilde{\Gamma}_M$ is properly defined, then $(x_1, \dots, x_{n_M}) \in \Gamma_M$. The same argument can be used to prove an analogous assertion for stiffness matrices, therefore $(\mathbf{P}^T \mathbf{M}_s \mathbf{P}, \mathbf{P}^T \mathbf{K}_s \mathbf{P}) \in \hat{\mathcal{V}}$. Since it has been proved that the original and the scaled problem are both solved by the same matrix \mathbf{P} , it is recommended to solve the scaled problem which is computationally more efficient.

3. Numerical examples

The proposed method has been implemented in Matlab, for the sake of numerical assessment. Three examples are shown in this Section, to demonstrate the capabilities of the developed strategy for partial assignment of natural frequencies.

Available state-of-the-art software has been exploited. In particular, Gurobi [41] has been used for optimization problem (6), together with the useful modelling language Yalmip [42]. For what concerns the numerical integration of differential equation (18), the Matlab built-in function `ode15s` for stiff equations has been used. In practice, since the limit for $t \rightarrow +\infty$ of the flow $\mathbf{P}(t)$ is sought, the differential equation is integrated in the interval $[0, T_f]$. For $T_f \gg 0$, the proposed procedure can find a matrix which approximates the stationary point of (18) up to machine precision and with a short computation time. Finally, the constrained linear least-squares problems that occur in the computation of the projections \mathcal{P}_1 and \mathcal{P}_2 have been solved with the Optimization

Toolbox in Matlab. Function `lsqlin` has been used, choosing the interior point algorithm among the available ones. If only lower bounds are specified, however, function `lsqnonneg` is preferred, provided that the linear least-squares problem is recast as an optimization problem with nonnegativity constraints. For example, suppose that the projection \mathcal{P}_1 is subjected only to the lower bound $\mathbf{x} \geq \mathbf{x}_0$, then the minimization problem can be recast as follows

$$\begin{aligned} \min_{\mathbf{x} \geq \mathbf{x}_0} \|\mathbf{S}_M \mathbf{x} - \boldsymbol{\delta m}\|_2^2 &\Leftrightarrow \min_{\mathbf{x} \geq \mathbf{x}_0} \|\mathbf{S}_M \mathbf{x} - \boldsymbol{\delta m} + \mathbf{S}_M \mathbf{x}_0 - \mathbf{S}_M \mathbf{x}_0\|_2^2 \\ &\Leftrightarrow \min_{\mathbf{x} - \mathbf{x}_0 \geq 0} \|\mathbf{S}_M (\mathbf{x} - \mathbf{x}_0) - (\boldsymbol{\delta m} - \mathbf{S}_M \mathbf{x}_0)\|_2^2. \end{aligned} \quad (28)$$

As the latter is a nonnegative least squares problem, it can be solved faster and more accurately with ad-hoc algorithms.

3.1. Cantilever beam

The first example is the cantilever beam pictured in Figure 2. The model consists of three Euler-Bernoulli beam elements, each of length $l = 1m$.

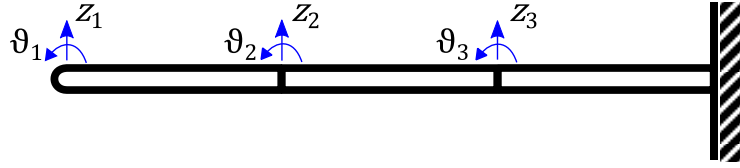

Figure 2. Cantilever beam

The considered system was studied in [30, 43] and hence it is taken as a benchmark here. The linear mass density ρA and the product of the Young's modulus and the moment of inertia EJ are shown in Table 1.

Table 1. Original values and determined modifications

Parameter	Original value	Constraint	Modification
ρA_1 [kg/m]	1.4	$[0, +\infty)$	+0.0000
ρA_2 [kg/m]	1.4	$[0, +\infty)$	+0.0000
ρA_3 [kg/m]	1.4	$[0, +\infty)$	+0.8043
EJ_1 [Nm ²]	27	$[0, +\infty)$	+0.8227
EJ_2 [Nm ²]	27	$[0, +\infty)$	+0.6334
EJ_2 [Nm ²]	27	$[0, +\infty)$	+9.3940

The resulting mass and stiffness matrices are

$$\mathbf{M}_0 = \begin{bmatrix} 1.56 & 0.66 & 0.54 & -0.39 & 0 & 0 \\ 0.66 & 0.36 & 0.39 & -0.27 & 0 & 0 \\ 0.54 & 0.39 & 3.12 & 0 & 0.54 & -0.39 \\ -0.39 & -0.27 & 0 & 0.72 & 0.39 & -0.27 \\ 0 & 0 & 0.54 & 0.39 & 3.12 & 0 \\ 0 & 0 & -0.39 & -0.27 & 0 & 0.72 \end{bmatrix};$$

$$\mathbf{K}_0 = \begin{bmatrix} 12 & 18 & -12 & 18 & 0 & 0 \\ 18 & 36 & -18 & 18 & 0 & 0 \\ -12 & -18 & 24 & 0 & -12 & 18 \\ 18 & 18 & 0 & 72 & -18 & 18 \\ 0 & 0 & -12 & -18 & 24 & 0 \\ 0 & 0 & 18 & 18 & 0 & 72 \end{bmatrix}.$$
(29)

The eigenvalues of the original system are shown in the first column of Table 2. The three lowest eigenvalues are wanted to be equal to $\mu_1 = 0.05$, $\mu_2 = 1.50$ and $\mu_3 = 11.0$, while the others should remain the same. The system matrices computed after direct updating are

$$\mathbf{M}_s = \begin{bmatrix} 1.5442 & 0.6523 & 0.5324 & -0.3788 & 0.0352 & -0.0004 \\ 0.6523 & 0.3567 & 0.3891 & -0.2662 & 0.0079 & -0.0007 \\ 0.5324 & 0.3891 & 3.1192 & -0.0119 & 0.4651 & -0.3905 \\ -0.3788 & -0.2662 & -0.0119 & 0.7145 & 0.3798 & -0.2664 \\ 0.0352 & 0.0079 & 0.4651 & 0.3798 & 3.1274 & 0.0183 \\ -0.0004 & -0.0007 & -0.3905 & -0.2664 & 0.0183 & 0.7200 \end{bmatrix};$$

$$\mathbf{K}_s = \begin{bmatrix} 12.0203 & 18.0091 & -11.9892 & 17.9917 & -0.0121 & 0.0004 \\ 18.0091 & 36.0039 & -17.9947 & 17.9971 & -0.0029 & -0.0001 \\ -11.9892 & -17.9947 & 24.0277 & 0.0037 & -11.9658 & 17.9955 \\ 17.9917 & 17.9971 & 0.0037 & 72.0027 & -17.9915 & 17.9994 \\ -0.0121 & -0.0029 & -11.9658 & -17.9915 & 24.0202 & -0.0084 \\ 0.0004 & -0.0001 & 17.9955 & 17.9994 & -0.0084 & 71.9992 \end{bmatrix}.$$
(30)

The eigenvalues of $(\mathbf{M}_s, \mathbf{K}_s)$ are shown in the second column of Table 2. It is supposed that the system parameters that can be modified are the linear mass densities ρA_i and the products of the Young's modulus and area moment of inertia EJ_i , for each beam element $i = 1, 2, 3$. Hence, the space of feasible systems defined in (9) means that $n_M = n_K = 3$ and

$$\begin{aligned}
\mathbf{M}_1 &= \frac{l}{420} \begin{bmatrix} 156 & 22l & 54 & -13l & 0 & 0 \\ 22l & 4l^2 & 13l & -3l^2 & 0 & 0 \\ 54 & 13l & 156 & -22l & 0 & 0 \\ -13l & -3l^2 & -22l & 4l^2 & 0 & 0 \\ 0 & 0 & 0 & 0 & 0 & 0 \\ 0 & 0 & 0 & 0 & 0 & 0 \end{bmatrix} & \mathbf{K}_1 &= \frac{1}{l^3} \begin{bmatrix} 12 & 6l & -12 & 6l & 0 & 0 \\ 6l & 4l^2 & -6l & 2l^2 & 0 & 0 \\ -12 & -6l & 12 & -6l & 0 & 0 \\ 6l & 2l^2 & -6l & 4l^2 & 0 & 0 \\ 0 & 0 & 0 & 0 & 0 & 0 \\ 0 & 0 & 0 & 0 & 0 & 0 \end{bmatrix} \\
\mathbf{M}_2 &= \frac{l}{420} \begin{bmatrix} 0 & 0 & 0 & 0 & 0 & 0 \\ 0 & 0 & 0 & 0 & 0 & 0 \\ 0 & 0 & 156 & 22l & 54 & -13l \\ 0 & 0 & 22l & 4l^2 & 13l & -3l^2 \\ 0 & 0 & 54 & 13l & 156 & -22l \\ 0 & 0 & -13l & -3l^2 & -22l & 4l^2 \end{bmatrix} & \mathbf{K}_2 &= \frac{1}{l^3} \begin{bmatrix} 0 & 0 & 0 & 0 & 0 & 0 \\ 0 & 0 & 0 & 0 & 0 & 0 \\ 0 & 0 & 12 & 6l & -12 & 6l \\ 0 & 0 & 6l & 4l^2 & -6l & 2l^2 \\ 0 & 0 & -12 & -6l & 12 & -6l \\ 0 & 0 & 6l & 2l^2 & -6l & 4l^2 \end{bmatrix} \\
\mathbf{M}_3 &= \frac{l}{420} \begin{bmatrix} 0 & 0 & 0 & 0 & 0 & 0 \\ 0 & 0 & 0 & 0 & 0 & 0 \\ 0 & 0 & 0 & 0 & 0 & 0 \\ 0 & 0 & 0 & 0 & 0 & 0 \\ 0 & 0 & 0 & 0 & 156 & 22l \\ 0 & 0 & 0 & 0 & 22l & 4l^2 \end{bmatrix} & \mathbf{K}_3 &= \frac{1}{l^3} \begin{bmatrix} 0 & 0 & 0 & 0 & 0 & 0 \\ 0 & 0 & 0 & 0 & 0 & 0 \\ 0 & 0 & 0 & 0 & 0 & 0 \\ 0 & 0 & 0 & 0 & 0 & 0 \\ 0 & 0 & 0 & 0 & 12 & 6l \\ 0 & 0 & 0 & 0 & 6l & 4l^2 \end{bmatrix}.
\end{aligned}$$

Moreover, the constraints in the second column of Table 1 are imposed. Hence the differential equation (18) is integrated until $T_f = 100$. Finally, the resulting system is

$$\begin{aligned}
\mathbf{M} &= \begin{bmatrix} 1.56 & 0.66 & 0.54 & -0.39 & 0 & 0 \\ 0.66 & 0.36 & 0.39 & -0.27 & 0 & 0 \\ 0.54 & 0.39 & 3.12 & 0 & 0.54 & -0.39 \\ -0.39 & -0.27 & 0 & 0.72 & 0.39 & -0.27 \\ 0 & 0 & 0.54 & 0.39 & 4.0162 & 0.3792 \\ 0 & 0 & -0.39 & -0.27 & 0.3792 & 0.9268 \end{bmatrix}; \\
\mathbf{K} &= \begin{bmatrix} 12.3657 & 18.5485 & -12.3657 & 18.5485 & 0 & 0 \\ 18.5485 & 37.0970 & -18.5485 & 18.5485 & 0 & 0 \\ -12.3657 & -18.5485 & 24.6472 & -0.1262 & -12.2815 & 18.4223 \\ 18.5485 & 18.5485 & -0.1262 & 73.9416 & -18.4223 & 18.4223 \\ 0 & 0 & -12.2815 & -18.4223 & 28.4567 & 5.8404 \\ 0 & 0 & 18.4223 & 18.4223 & 5.8404 & 85.3700 \end{bmatrix}.
\end{aligned} \tag{31}$$

Such a system can be obtained by means of modification to the original system given in the third column of Table 1. The eigenvalues of the system (\mathbf{M}, \mathbf{K}) are shown in Table 2. These results prove that the three lowest eigenvalues are close to the objectives, with respect to the original system design. At the same time, the spill-over that affects the remaining eigenvalues is very low, in fact the relative error is about 2% for all the three cases.

Table 2. Obtained eigenvalues

	$(\mathbf{M}_0, \mathbf{K}_0)$	$(\mathbf{M}_s, \mathbf{K}_s)$	(\mathbf{M}, \mathbf{K})
Eigenvalues	$3.6346 \cdot 10^{-2}$	$5.0000 \cdot 10^{-2}$	$4.6117 \cdot 10^{-2}$
	$1.4365 \cdot 10^0$	$1.5000 \cdot 10^0$	$1.5004 \cdot 10^0$
	$1.1470 \cdot 10^1$	$1.1000 \cdot 10^1$	$1.1021 \cdot 10^1$
	$5.8167 \cdot 10^1$	$5.8167 \cdot 10^1$	$5.6863 \cdot 10^1$
	$2.0602 \cdot 10^2$	$2.0602 \cdot 10^2$	$2.0151 \cdot 10^2$
	$8.1884 \cdot 10^2$	$8.1884 \cdot 10^2$	$8.3430 \cdot 10^2$
Rel. errors [%]	27.3082	0.0000	7.7666
	4.2302	0.0000	0.0276
	4.2702	0.0000	0.1927
	-	0.0000	2.2407
	-	0.0000	2.1915
	-	0.0000	1.8883

3.2. Lumped parameter systems

Although for mass-spring systems the eigenvalues assignment without spill-over problem has been already solved in [29], it is worthwhile to demonstrate the performance of the proposed method with one of the examples in the cited paper. This is a 10-degree of freedom system shown in Figure 3. The nominal values of the mass and stiffness parameters are listed in the first column of Table 3.

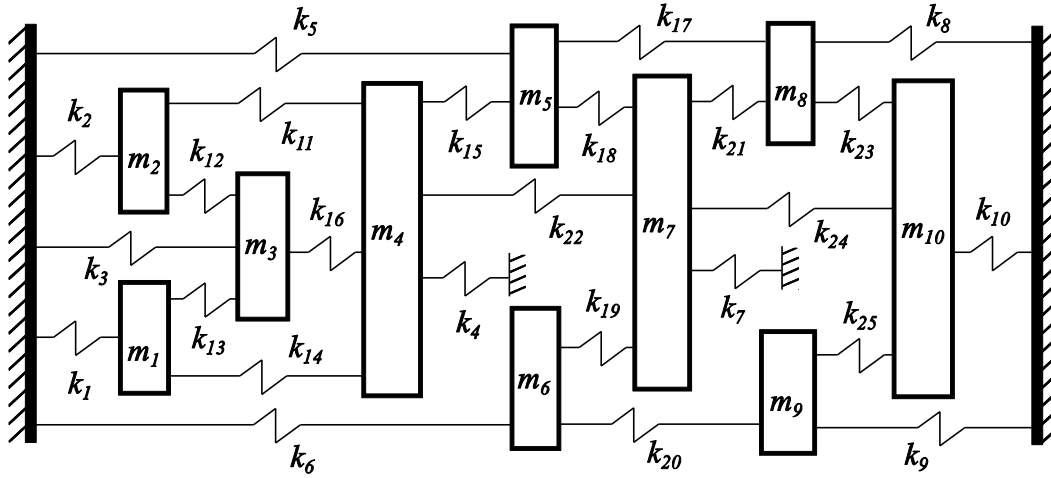

Figure 3. Lumped parameter system

The two lowest eigenvalues are wanted to be equal to $\mu_1 = 9012$ and $\mu_2 = 12118$, while the others should be left unchanged [29]. It is supposed, in accordance with the benchmark, that all the masses and springs can be modified. Differential equation (18) is solved until $T_f = 30$. To improve the numerical integration, the scaling factors $\alpha = 1$ and $\beta = 10^{-5}$ are employed. The determined modifications with respect to the original system parameters, which comply with the prescribed constraints, are shown in Table 3. The eigenvalues comparison, shown in Table 4, proves that the proposed method can assign the two desired frequencies without spill-over. Such a result is comparable to the one obtained in [29], in terms of accuracy of the assignment. It should be

noted here that the determined modifications to make the desired partial frequency assignment in this investigation are different from those reported in [29], which reflects the non-uniqueness in structural modifications for partial frequency assignment.

Table 3. Computed modifications.

Parameter	Original value	Constraint	Modification
m_1 [kg]	30	$[-30, +\infty)$	-1.3354
m_2 [kg]	35	$[-35, +\infty)$	-1.9799
m_3 [kg]	40	$[-40, +\infty)$	-2.6579
m_4 [kg]	45	$[-45, +\infty)$	-3.4365
m_5 [kg]	45	$[-45, +\infty)$	-4.2918
m_6 [kg]	45	$[-45, +\infty)$	-5.4105
m_7 [kg]	40	$[-40, +\infty)$	-2.1045
m_8 [kg]	35	$[-35, +\infty)$	-1.9893
m_9 [kg]	30	$[-30, +\infty)$	-1.5407
m_{10} [kg]	25	$[-25, +\infty)$	-0.1986
k_1 [N/m]	$2.4 \cdot 10^5$	$[-2.4 \cdot 10^5, +\infty)$	$3.0118 \cdot 10^4$
k_2 [N/m]	$2.4 \cdot 10^5$	$[-2.4 \cdot 10^5, +\infty)$	$6.1159 \cdot 10^4$
k_3 [N/m]	$2.4 \cdot 10^5$	$[-2.4 \cdot 10^5, +\infty)$	$1.2533 \cdot 10^5$
k_4 [N/m]	$2.4 \cdot 10^5$	$[-2.4 \cdot 10^5, +\infty)$	$1.8437 \cdot 10^5$
k_5 [N/m]	$2.4 \cdot 10^5$	$[-2.4 \cdot 10^5, +\infty)$	$-5.1242 \cdot 10^4$
k_6 [N/m]	$2.4 \cdot 10^5$	$[-2.4 \cdot 10^5, +\infty)$	$1.1121 \cdot 10^5$
k_7 [N/m]	$2.4 \cdot 10^5$	$[-2.4 \cdot 10^5, +\infty)$	$2.3010 \cdot 10^5$
k_8 [N/m]	$2.4 \cdot 10^5$	$[-2.4 \cdot 10^5, +\infty)$	$6.5613 \cdot 10^3$
k_9 [N/m]	$2.4 \cdot 10^5$	$[-2.4 \cdot 10^5, +\infty)$	$5.9681 \cdot 10^4$
k_{10} [N/m]	$2.4 \cdot 10^5$	$[-2.4 \cdot 10^5, +\infty)$	$7.5688 \cdot 10^4$
k_{11} [N/m]	$2.4 \cdot 10^5$	$[-2.4 \cdot 10^5, +\infty)$	$-5.6379 \cdot 10^4$
k_{12} [N/m]	$2.4 \cdot 10^5$	$[-2.4 \cdot 10^5, +\infty)$	$-4.1956 \cdot 10^4$
k_{13} [N/m]	$2.4 \cdot 10^5$	$[-2.4 \cdot 10^5, +\infty)$	$-2.6967 \cdot 10^4$
k_{14} [N/m]	$2.4 \cdot 10^5$	$[-2.4 \cdot 10^5, +\infty)$	$-3.3854 \cdot 10^4$
k_{15} [N/m]	$2.4 \cdot 10^5$	$[-2.4 \cdot 10^5, +\infty)$	$-3.7155 \cdot 10^4$
k_{16} [N/m]	$2.4 \cdot 10^5$	$[-2.4 \cdot 10^5, +\infty)$	$-7.0636 \cdot 10^4$
k_{17} [N/m]	$2.4 \cdot 10^5$	$[-2.4 \cdot 10^5, +\infty)$	$-9.1187 \cdot 10^3$
k_{18} [N/m]	$2.4 \cdot 10^5$	$[-2.4 \cdot 10^5, +\infty)$	$-3.4443 \cdot 10^4$
k_{19} [N/m]	$2.4 \cdot 10^5$	$[-2.4 \cdot 10^5, +\infty)$	$-1.2269 \cdot 10^5$
k_{20} [N/m]	$2.4 \cdot 10^5$	$[-2.4 \cdot 10^5, +\infty)$	$-6.2758 \cdot 10^4$
k_{21} [N/m]	$2.4 \cdot 10^5$	$[-2.4 \cdot 10^5, +\infty)$	$-3.7457 \cdot 10^4$
k_{12} [N/m]	$2.4 \cdot 10^5$	$[-2.4 \cdot 10^5, +\infty)$	$-3.1824 \cdot 10^4$
k_{23} [N/m]	$2.4 \cdot 10^5$	$[-2.4 \cdot 10^5, +\infty)$	$-1.3914 \cdot 10^4$
k_{24} [N/m]	$2.4 \cdot 10^5$	$[-2.4 \cdot 10^5, +\infty)$	$-1.5011 \cdot 10^4$
k_{25} [N/m]	$2.4 \cdot 10^5$	$[-2.4 \cdot 10^5, +\infty)$	$-3.1275 \cdot 10^4$

Table 4. Eigenvalues comparison

	$(\mathbf{M}_0, \mathbf{K}_0)$	$(\mathbf{M}_s, \mathbf{K}_s)$	(\mathbf{M}, \mathbf{K})
Eigenvalues	$6.4024 \cdot 10^3$	$9.0120 \cdot 10^3$	$9.0120 \cdot 10^3$
	$9.6317 \cdot 10^3$	$1.2118 \cdot 10^4$	$1.2118 \cdot 10^4$
	$1.4622 \cdot 10^4$	$1.4622 \cdot 10^4$	$1.4622 \cdot 10^4$
	$2.2122 \cdot 10^4$	$2.2122 \cdot 10^4$	$2.2122 \cdot 10^4$
	$2.3065 \cdot 10^4$	$2.3065 \cdot 10^4$	$2.3065 \cdot 10^4$
	$2.8474 \cdot 10^4$	$2.8474 \cdot 10^4$	$2.8474 \cdot 10^4$
	$3.2227 \cdot 10^4$	$3.2227 \cdot 10^4$	$3.2227 \cdot 10^4$
	$3.5759 \cdot 10^4$	$3.5759 \cdot 10^4$	$3.5759 \cdot 10^4$
	$4.2302 \cdot 10^4$	$4.2302 \cdot 10^4$	$4.2302 \cdot 10^4$
Rel. errors [%]	$4.9129 \cdot 10^4$	$4.9129 \cdot 10^4$	$4.9129 \cdot 10^4$
	28.9570	0.0000	0.0000
	20.5172	0.0000	0.0000
	-	0.0000	0.0000
	-	0.0000	0.0000
	-	0.0000	0.0000
	-	0.0000	0.0000
	-	0.0000	0.0000
	-	0.0000	0.0000

3.3. Linear vibratory feeder

The third example of frequency assignment is performed on a model of a linear vibratory feeder, such as those employed in product conveyance [44]. The system, represented in Figure 4, consists of a beam of length $L = 2m$, modelled as four Euler-Bernoulli elements, with two elastic supports (i.e. k_1 and k_2) and three electromagnetic actuators, modelled as lumped masses (i.e. m_1 , m_2 and m_3).

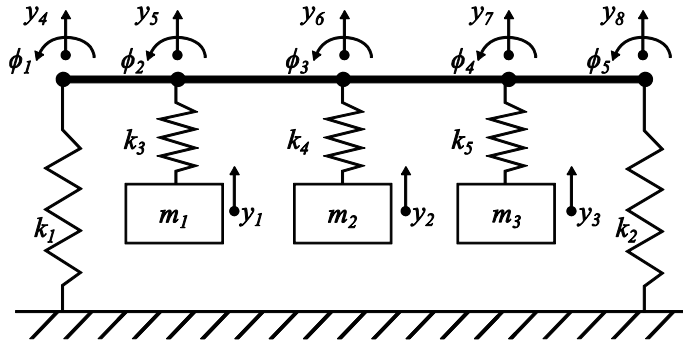

Figure 4. Linear vibratory feeder

Such a lumped-and-distributed parameter model has 13 degrees of freedom. The nominal values of the physical quantities that characterize the system are shown in the first column of Table 5. It is wanted that the third and the fourth natural frequencies become 30 Hz ($\mu_1 = 35530.58$) and 45 Hz ($\mu_2 = 79943.80$), respectively, while the

other frequencies should not be affected by the modifications. It is supposed that the linear mass density ρA and the product of Young's modulus and moment of inertia EJ of the beam can be modified, as well as the masses m_i , for $i=1,2,3$ and the springs k_i , for $i=1,\dots,5$. Differential equation (18) is solved until $T_f = 100$, employing the scaling factors $\alpha=1$ and $\beta=10^{-8}$ to improve the numerical integration. The computed optimal modifications are shown in the third column of Table 5. The eigenvalues comparison in Table 6 exhibits the accuracy of the obtained assignment: the difference between the desired frequencies and the obtained ones is significantly reduced and the spill-over that affects the remaining frequencies is very low (about 2%, at most). Since this particular test-case represents an industrial machine, the proposed method constitutes a proper tool for design of vibrating systems.

Table 5. Computed modifications

Parameter	Original value	Constraint	Scaling coefficient	Modification
m_1 [kg]	25	[-5,+10]	$\eta_1 = 1$	-0.0500
m_2 [kg]	25	[-5,+10]	$\eta_2 = 1$	-0.4075
m_3 [kg]	25	[-5,+10]	$\eta_3 = 1$	-0.0500
ρA [kg/m]	15.8	[-0.8,+5]	$\eta_4 = 1$	-0.0031
k_1 [N/m]	$1.0 \cdot 10^3$	$[0,+5 \cdot 10^2]$	$\tau_1 = 10^3$	$0.0000 \cdot 10^0$
k_2 [N/m]	$1.0 \cdot 10^3$	$[0,+5 \cdot 10^2]$	$\tau_2 = 10^3$	$0.0000 \cdot 10^0$
k_3 [N/m]	$8.7 \cdot 10^5$	$[0,+1.3 \cdot 10^5]$	$\tau_3 = 10^5$	$1.8744 \cdot 10^4$
k_4 [N/m]	$8.7 \cdot 10^5$	$[0,+1.3 \cdot 10^5]$	$\tau_4 = 10^5$	$1.3686 \cdot 10^4$
k_5 [N/m]	$8.7 \cdot 10^5$	$[0,+1.3 \cdot 10^5]$	$\tau_5 = 10^5$	$1.8744 \cdot 10^4$
EJ [Nm ²]	$4.5 \cdot 10^5$	$[-5 \cdot 10^4,+10^5]$	$\tau_6 = 10^5$	$-9.9386 \cdot 10^1$

Table 6. Obtained eigenvalues

	$(\mathbf{M}_0, \mathbf{K}_0)$	$(\mathbf{M}_s, \mathbf{K}_s)$	(\mathbf{M}, \mathbf{K})
Eigenvalues	$1.8747 \cdot 10^1$	$1.8747 \cdot 10^1$	$1.8838 \cdot 10^1$
	$8.6704 \cdot 10^1$	$8.6704 \cdot 10^1$	$8.6809 \cdot 10^1$
	$3.3855 \cdot 10^4$	$3.5531 \cdot 10^4$	$3.4841 \cdot 10^4$
	$7.5322 \cdot 10^4$	$7.9944 \cdot 10^4$	$7.7001 \cdot 10^4$
	$1.1401 \cdot 10^5$	$1.1401 \cdot 10^5$	$1.1642 \cdot 10^5$
	$9.4036 \cdot 10^5$	$9.4036 \cdot 10^5$	$9.4121 \cdot 10^5$
	$6.9338 \cdot 10^6$	$6.9338 \cdot 10^6$	$6.9353 \cdot 10^6$
	$2.6582 \cdot 10^7$	$2.6582 \cdot 10^7$	$2.6584 \cdot 10^7$
	$8.8765 \cdot 10^7$	$8.8765 \cdot 10^7$	$8.8763 \cdot 10^7$
	$2.1765 \cdot 10^8$	$2.1765 \cdot 10^8$	$2.1765 \cdot 10^8$
	$5.2345 \cdot 10^8$	$5.2345 \cdot 10^8$	$5.2344 \cdot 10^8$
	$1.4514 \cdot 10^9$	$1.4514 \cdot 10^9$	$1.4514 \cdot 10^9$
	$1.7691 \cdot 10^9$	$1.7691 \cdot 10^9$	$1.7691 \cdot 10^9$

-	0.0000	0.4852
-	0.0000	0.1207
4.7162	0.0000	1.9408
5.7813	0.0000	3.6805
-	0.0000	2.1182
-	0.0000	0.0904
-	0.0000	0.0222
-	0.0000	0.0081
-	0.0000	0.0024
-	0.0000	0.0022
-	0.0000	0.0024
-	0.0000	0.0026
-	0.0000	0.0027

3.4. Remark on the alteration of eigenvectors

Finally, it should be noted that even though eigenvector assignment is not an object of this paper, the presented method actually causes small changes to eigenvectors, which is a nice property to have. One demonstration of this is the example of Subsection 3.1, the Modal Assurance Criterion (MAC) values of which are given in Table 7. Diagonal MAC values being close to one in Table 7 are a strong indication that the eigenvectors of the modified structure are very close to those of the original.

Table 7. MAC values of the first example

MAC(i, j)		i -th eigenvector of the original system					
		$i=1$	$i=2$	$i=3$	$i=4$	$i=5$	$i=6$
j -th eigenvector of the modified system	$j=1$	0.9998	0.2384	0.1952	0.1511	0.1130	0.1849
	$j=2$	0.2272	0.9998	0.3152	0.1771	0.2298	0.3213
	$j=3$	0.1940	0.3605	0.9960	0.3044	0.2986	0.3710
	$j=4$	0.1595	0.1745	0.3404	0.9955	0.2514	0.3269
	$j=5$	0.1124	0.2347	0.2926	0.2742	0.9971	0.3141
	$j=6$	0.1806	0.3211	0.3545	0.3137	0.3206	0.9998

4. Conclusions

This paper proposes a method aimed at assigning natural frequencies while avoiding spill-over (partial assignment), suitable for arbitrary vibrating systems. A three-step approach is established and the computational difficulties that arise in the numerical computations are carefully addressed. The numerical tests carried out show that the proposed method constitutes a practical and reliable way to alter a subset of the natural frequencies by computing suitable modifications of the system parameters. It has been proved that spill-over can be often prevented, or it is very small even if it occurs. In conclusion, the proposed method actually widens the capabilities of structural modifications, allowing partial eigenvalues assignment even for complex systems such as finite element models.

Acknowledgements

A large part of this work was carried out during the first author's visit to the University of Liverpool. The first author also acknowledges the financial support of the FSU foundation ("Fondazione Studi Universitari"—Vicenza) through a Ph.D. scholarship. Prof. Jiafan Zhang of School of Mechanical Engineering, Wuhan Polytechnic University, China provided some helpful advice on numerical treatment.

References

- [1] K. Farahani, H. Bahai, An inverse strategy for relocation of eigenfrequencies in structural design. Part I: first order approximate solutions, *Journal of Sound and Vibration* 274 (3) (2004) 481–505. doi:10.1016/j.jsv.2003.11.009.
- [2] D. D. Sivan, Y. M. Ram, Mass and stiffness modifications to achieve desired natural frequencies, *Communications in numerical methods in engineering* 12 (9) (1996) 531–542. doi:10.1002/(SICI)1099-0887(199609)12:9<3C531::AID-CNM999%3E3.0.CO;2-S.
- [3] A. Kyprianou, J. E. Mottershead, H. Ouyang, Assignment of natural frequencies by an added mass and one or more springs, *Mechanical Systems and Signal Processing* 18 (2) (2004) 263–289. doi:10.1016/S0888-3270(02)00220-0.
- [4] E. Chu, B. Datta, Numerically robust pole assignment for second-order systems, *International Journal of Control* 64 (6) (1996) 1113–1127. doi:10.1080/00207179608921677.
- [5] B. N. Datta, S. Elhay, Y. M. Ram, Orthogonality and partial pole assignment for the symmetric definite quadratic pencil, *Linear Algebra and its Applications* 257 (1997) 29–48. doi:10.1016/S0024-3795(96)00036-5.
- [6] J. E. Mottershead, Y. M. Ram, Receptance method in active vibration control, *AIAA Journal* 45 (3) (2007) 562–567. doi:10.2514/1.24349.
- [7] Y. Saad, Projection and deflation method for partial pole assignment in linear state feedback, *IEEE Transactions on Automatic Control* 33 (3) (1988) 290–297. doi:10.1109/9.406.
- [8] B. N. Datta, D. R. Sarkissian, Partial eigenvalue assignment in linear systems: existence, uniqueness and numerical solution, in: *Proceedings of the Mathematical Theory of Networks and Systems (MTNS)*, Notre Dame, Citeseer, 2002.
- [9] Y. Ram, S. Elhay, Pole assignment in vibratory systems by multi-input control, *Journal of Sound and Vibration* 230 (2) (2000) 309–321. doi:10.1006/jsvi.1999.2622.
- [10] X. Mao, H. Dai, Minimum norm partial eigenvalue assignment of high order linear system with no spill-over, *Linear Algebra and its Applications* 438 (5) (2013) 2136–2154. doi:10.1016/j.laa.2012.10.049.
- [11] M. Ghandchi Tehrani, R. N. Elliott, J. E. Mottershead, Partial pole placement in structures by the method of receptances: theory and experiments, *Journal of Sound and Vibration* 329 (24) (2010) 5017–5035. doi:10.1016/j.jsv.2010.06.018.
- [12] K. V. Singh, R. N. Brown, R. Kolonay, Receptance-based active aeroelastic control with embedded control surfaces having actuator dynamics, *Journal of Aircraft* (0) (2016) 830–845. doi:10.2514/1.C033658.
- [13] Z.-J. Bai, Q.-Y. Wan, Partial quadratic eigenvalue assignment in vibrating structures using receptances and system matrices, *Mechanical Systems and Signal Processing* 88 (2017) 290–301. doi:10.1016/j.ymssp.2016.11.020.
- [14] Y. Ram, J. Mottershead, M. Ghandchi Tehrani, Partial pole placement with time delay in structures using the receptance and the system matrices, *Linear Algebra and its Applications* 434 (7) (2011) 1689–1696. doi:10.1016/j.laa.2010.07.014.
- [15] Z.-J. Bai, M.-X. Chen, B. N. Datta, Minimum norm partial quadratic eigenvalue assignment with time delay in vibrating structures using the receptance and the system matrices, *Journal of Sound and Vibration* 332 (4) (2013) 780–794. doi:10.1016/j.jsv.2012.10.015.

- [16] K. V. Singh, R. Dey, B. N. Datta, Partial eigenvalue assignment and its stability in a time delayed system, *Mechanical Systems and Signal Processing* 42 (1) (2014) 247–257. doi:10.1016/j.ymsp.2013.08.028.
- [17] J. Qian, S. Xu, Robust partial eigenvalue assignment problem for the second-order system, *Journal of Sound and Vibration* 282 (3) (2005) 937–948. doi:10.1016/j.jsv.2004.03.046.
- [18] S. Xu, J. Qian, Orthogonal basis selection method for robust partial eigenvalue assignment problem in second-order control systems, *Journal of Sound and Vibration* 317 (1) (2008) 1–19. doi:10.1016/j.jsv.2008.03.002.
- [19] Z.-J. Bai, B. N. Datta, J. Wang, Robust and minimum norm partial quadratic eigenvalue assignment in vibrating systems: a new optimization approach, *Mechanical Systems and Signal Processing* 24 (3) (2010) 766–783. doi:10.1016/j.ymsp.2009.09.014.
- [20] M. Ghandchi Tehrani, J. E. Mottershead, A. T. Shenton, Y. M. Ram, Robust pole placement in structures by the method of receptances, *Mechanical Systems and Signal Processing* 25 (1) (2011) 112–122. doi:10.1016/j.ymsp.2010.04.005.
- [21] X. Mao, H. Dai, Partial eigenvalue assignment with time-delay robustness, *Numerical Algebra, Control and Optimization* 3 (2) (2013) 207–221. doi:10.3934/naco.2013.3.207.
- [22] J. Zhang, H. Ouyang, J. Yang, Partial eigenstructure assignment for undamped vibration systems using acceleration and displacement feedback, *Journal of Sound and Vibration* 333 (1) (2014) 1–12. doi:10.1016/j.jsv.2013.08.040.
- [23] Y. Cai, S. Xu, On a quadratic inverse eigenvalue problem, *Inverse Problems* 25 (8) (2009) 085004. doi:10.1088/0266-5611/25/8/085004.
- [24] Y.-F. Cai, Y.-C. Kuo, W.-W. Lin, S.-F. Xu, Solutions to a quadratic inverse eigenvalue problem, *Linear Algebra and its Applications* 430 (5-6) (2009) 1590–1606. doi:10.1016/j.laa.2008.04.015.
- [25] X. Mao, H. Dai, Structure preserving eigenvalue embedding for undamped gyroscopic systems, *Applied Mathematical Modelling* 38 (17) (2014) 4333–4344. doi:10.1016/j.apm.2014.02.016.
- [26] M. Gürgöze, et al., Preserving the fundamental frequencies of beams despite mass attachments, *Journal of Sound and Vibration* 235 (2) (2000) 345–359. doi:10.1006/jsvi.1999.2884.
- [27] V. Mermertas, M. Gürgöze, Preservation of the fundamental natural frequencies of rectangular plates with mass and spring modifications, *Journal of Sound and Vibration* 276 (1) (2004) 440–448. doi:10.1016/j.jsv.2003.10.044.
- [28] O. Çakar, Mass and stiffness modifications without changing any specified natural frequency of a structure, *Journal of Vibration and Control* 17 (5) (2011) 769–776. doi:10.1177/1077546310376084.
- [29] H. Ouyang, J. Zhang, Passive modifications for partial assignment of natural frequencies of mass-spring systems, *Mechanical Systems and Signal Processing* 50 (2015) 214–226. doi:10.1016/j.ymsp.2014.05.022.
- [30] J. Yang, H. Ouyang, J.-F. Zhang, A new method of updating mass and stiffness matrices simultaneously with no spillover, *Journal of Vibration and Control* 22 (5) (2014) 1181–1189. doi:10.1177/1077546314535278.
- [31] G. Gladwell, Isospectral vibrating beams, in: *Proceedings of the Royal Society of London A: Mathematical, Physical and Engineering Sciences*, Vol. 458, The Royal Society, 2002, pp. 2691–2703. doi:10.1098/rspa.2002.0993.

- [32] M. T. Chu, N. Del Buono, Total decoupling of general quadratic pencils, Part II: Structure preserving isospectral flows, *Journal of Sound and Vibration* 309 (1) (2008) 112–128. doi:10.1016/j.jsv.2007.05.052.
- [33] E. D. Andersen, K. D. Andersen, *The Mosek Interior Point Optimizer for Linear Programming: An Implementation of the Homogeneous Algorithm*, Springer US, Boston, MA, 2000, pp. 197–232. doi:10.1007/978-1-4757-3216-0_8.
- [34] J. Sturm, Using SeDuMi 1.02, a MATLAB toolbox for optimization over symmetric cones, *Optimization Methods and Software* 11–12 (1999) 625–653. doi:10.1080/10556789908805766.
- [35] K.-C. Toh, M. J. Todd, R. H. Tütüncü, SDPT3—a MATLAB software package for semidefinite programming, version 1.3, *Optimization Methods and Software* 11 (1-4) (1999) 545–581. doi:10.1080/10556789908805762.
- [36] H. Ouyang, D. Richiedei, A. Trevisani, G. Zanardo, Eigenstructure assignment in undamped vibrating systems: a convex-constrained modification method based on receptances, *Mechanical Systems and Signal Processing* 27 (2012) 397–409. doi:10.1016/j.ymsp.2011.09.010.
- [37] M. T. Chu, Q. Guo, On the least squares approximation of symmetric-definite pencils subject to generalized spectral constraints, *SIAM Journal on Matrix Analysis and Applications* 19 (1) (1998) 1–20. doi:10.1137/S0895479895285135.
- [38] H.-Y. Fan, W.-W. Lin, P. Van Dooren, Normwise scaling of second order polynomial matrices, *SIAM journal on matrix analysis and applications* 26 (1) (2004) 252–256. doi:10.1137/S0895479803434914.
- [39] N. J. Higham, D. S. Mackey, F. Tisseur, S. D. Garvey, Scaling, sensitivity and stability in the numerical solution of quadratic eigenvalue problems, *International journal for numerical methods in engineering* 73 (3) (2008) 344–360. doi:10.1002/nme.2076.
- [40] H. P. Langtangen, G. K. Pedersen, *Scaling of Differential Equations*, Springer, 2016. doi:10.1007/978-3-319-32726-6.
- [41] Gurobi Optimization, Inc., *Gurobi optimizer reference manual* (2016).
- [42] J. Löfberg, YALMIP: A toolbox for modeling and optimization in MATLAB, in: *Proceedings of the CACSD Conference*, Taipei, Taiwan, 2004. doi:10.1109/CACSD.2004.1393890.
- [43] X. Mao, H. Dai, Finite element model updating with positive definiteness and no spill-over, *Mechanical Systems and Signal Processing* 28 (2012) 387–398. doi:10.1016/j.ymsp.2011.11.002.
- [44] R. Caracciolo, D. Richiedei, A. Trevisani, G. Zanardo, Designing vibratory linear feeders through an inverse dynamic structural modification approach, *The International Journal of Advanced Manufacturing Technology* 80 (9-12) (2015) 1587–1599. doi:10.1007/s00170-015-7096-0.