



THE UNIVERSITY *of* EDINBURGH

Edinburgh Research Explorer

Process Configuration Studies of the Amine Capture Process for Coal-fired Power Plants

Citation for published version:

Ahn, H, Luberti, M, Liu, Z & Brandani, S 2013, 'Process Configuration Studies of the Amine Capture Process for Coal-fired Power Plants' International Journal of Greenhouse Gas Control, vol. 16, pp. 29-40.
DOI: [10.1016/j.ijggc.2013.03.002](https://doi.org/10.1016/j.ijggc.2013.03.002)

Digital Object Identifier (DOI):

[10.1016/j.ijggc.2013.03.002](https://doi.org/10.1016/j.ijggc.2013.03.002)

Link:

[Link to publication record in Edinburgh Research Explorer](#)

Document Version:

Publisher's PDF, also known as Version of record

Published In:

International Journal of Greenhouse Gas Control

General rights

Copyright for the publications made accessible via the Edinburgh Research Explorer is retained by the author(s) and / or other copyright owners and it is a condition of accessing these publications that users recognise and abide by the legal requirements associated with these rights.

Take down policy

The University of Edinburgh has made every reasonable effort to ensure that Edinburgh Research Explorer content complies with UK legislation. If you believe that the public display of this file breaches copyright please contact openaccess@ed.ac.uk providing details, and we will remove access to the work immediately and investigate your claim.



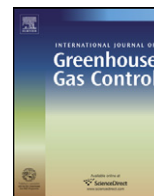

Process configuration studies of the amine capture process for coal-fired power plants



Hyungwoong Ahn*, Mauro Luberti, Zhengyi Liu, Stefano Brandani

Scottish Carbon Capture and Storage Centre, Institute for Materials and Processes, School of Engineering, The University of Edinburgh, Mayfield Road, Edinburgh EH9 3JL, UK

ARTICLE INFO

Article history:

Received 14 December 2012
Received in revised form 19 February 2013
Accepted 1 March 2013

Keywords:

Amine process configuration
Carbon capture
MEA
Process integration

ABSTRACT

This study reports the detailed evaluation of ten different configurations of amine capture processes using 30 wt% aqueous monoethanolamine (MEA) solvent to capture 90% CO₂ from an exemplary sub-critical PC-fired boiler power plant. The process configurations are compared with respect to total energy consumption, including thermal and electrical energy used. The comparison includes known configurations available in the literature and in patents. Additional configurations which lead to improved amine capture processes are presented, which result in further reduction in the reboiler heat duty. The use of detailed process flowsheet simulations enables the quantification of the effect of using multiple strategies in achieving greater reduction in the energy required for the integrated carbon capture and compression units. The simulations are also constrained to limit temperatures below conditions that lead to amine thermal degradation. Compared to the simple absorber/stripper configuration, which reduced the efficiency of the power plant by 9–12%, the multiple alteration system proposed in this study achieves the same capture rate with a 0.9% gain of net plant efficiency only by an advanced amine process configuration and a reduction in steam consumption of up to 37%.

© 2013 Elsevier Ltd. All rights reserved.

1. Introduction

Aqueous alkanolamine based capture processes for post-combustion carbon capture from coal fired power plants are at a mature stage of technical development, are considered most reliable, and are capable of producing ultra-pure CO₂ (DOE, 2007a; ZEP, 2010). These plants are therefore closest to commercialisation among various separation technologies. However, it is well known that the integration of amine process with pulverized coal (PC) – fired boiler power plants will reduce the power plant efficiency by more than 9% (DOE, 2007a). This significant penalty of this retrofit option is due to the enormous heat duty in the steam stripper, with steam extracted from the IP/LP crossover in the existing steam cycle (DOE, 2007a).

While significant effort has been devoted to the invention of new solvents having lower heat of reaction in order to reduce the energy consumption for solvent regeneration (Puxty et al., 2009), these approaches mostly result in an increase in the size of columns and other equipment in the amine process to compensate for the weak reactivity. This makes it difficult to apply these solutions to large sources emitting flue gases at a very high flowrates. In this respect,

MEA (monoethanolamine), which is relatively cheap and has very strong reactivity to CO₂ even at very low CO₂ partial pressures, is still being considered as a first choice in designing an amine process for carbon capture from coal-fired power plants (DECC, 2011).

In order to improve post-combustion gas purification design, a detailed dynamic mathematical model, which describes each step of CO₂ capture, for wide domain of operating conditions is required. In this field recent works have focused on the modeling of the absorber column operations (Simon et al., 2011) and on the evaluation of several combinations of mass transfer and hydraulic models in order to predict with accuracy the process parameters and column parameters (Cormos and Gaspar, 2012).

From the process point of view, main concerns in process integration of the post combustion CO₂ capture plant and the power plant lie with the very significant steam extraction from the existing steam cycle to supply heat to the amine capture process. A steam stripping method using a separate steam generator can avoid this problem, decoupling the units and eliminating the need for plant integration, but this approach results in a higher plant efficiency penalty (IEAGHG, 2011). It is possible to supply the amine capture process with steam from the steam cycle in the power plant but the amount of steam extracted is so large that it can cause a major alteration of the steam cycle design and leads to higher operational complexity. Therefore, it is worth studying different process configurations where it is possible to reduce the steam requirement

* Corresponding author. Tel.: +44 1316505891.
E-mail address: h.ahn@ed.ac.uk (H. Ahn).

in the amine capture process since it would alleviate the extent of alteration of existing steam cycles imposed by the retrofit of a carbon capture unit to the power plant. In this respect, it could be deemed more efficient to use less steam and more electricity in operating an amine process from the viewpoint of its operability as long as the total energy consumption is kept more or less constant.

In this study, using Honeywell's UniSim process simulator and the amine thermodynamic package, we have evaluated eight amine process configurations inspired by patents and papers (Karimi et al., 2011a; Cousins et al., 2011), which can represent the features that all reported amine processes have, plus two new configurations based on the same feed composition, pressure, and temperature conditions.

2. Simulation basis

The schematic diagram of a typical PC-boiler power plant used in this study is shown in Fig. 1. This allows to define the flowrate and composition of the flue gas flowing to a post-combustion amine process and determines the steam condition available for the operation of the stripper reboiler. Low pressure (LP) steam at around 300 kPa should be taken from the steam cycle and used in the amine process in order to keep the stripper reboiler operating at 120 °C. However, the steam pressure at the IP/LP crossover varies for different power plants so for most typical power plants one has to consider the installation of either a throttling valve or a let-down turbine to regulate the steam pressure to around 300 kPa. In this work, an exemplary 550 MW coal-fired power plant with sub-critical steam cycle (16.7 MPa/565.6 °C/565.6 °C) has been simulated using Honeywell UniSim based on DOE report (2007a). This system has the IP/LP crossover pressure set at 1.2 MPa, and the outlet of the let-down turbine set at 310 kPa. However, the steam after the let-down turbine cannot be sent to the stripper reboiler directly because its temperature is as high as 254 °C. A desuperheater after the let-down turbine has the function to cool the superheated steam to a saturated steam, which is at a temperature of 134 °C. This saturated steam temperature is chosen considering the stripper reboiler temperature of 120 °C with the hot minimum temperature approach around 14 °C. The use of saturated steam allows the stripper reboiler to be operated maintaining the hot side temperature constant and preventing any hot spot. Hot spots could cause amine thermal degradation and should be avoided using saturated steam at the correct pressure. The condensed saturated water from the stripper reboiler is returned to the deaerator in the steam cycle after being pumped to 1.2 MPa.

Following the same basis of the DOE report (DOE, 2007a), the flue gas after the flue gas desulphurisation (FGD) unit is at 57.2 °C and 117 kPa and saturated with water. The flue gas is sent to a direct contact cooler (DCC), where it is cooled to 32 °C and part of the water is condensed out. The flue gas is then pressurized to 131 kPa by a blower to overcome the pressure drop in the amine absorber. The use of cooled gas allows a reduction in the work required in the blower. The conditions of the gas stream entering the amine capture unit are: 43.6 °C and 131 kPa and its mass flowrate is 2.067×10^6 kg/h in this study. The flue gas composition is 4.06% H₂O, 2.20% O₂, 78.09% N₂ and 15.65% CO₂ by volume. All the schemes referring to Figs. 2–11 were simulated on the basis of the same flue gas and are set to capture 90% of the CO₂. It should be noted that all the simulation cases had been constructed so that the lean amine entering the absorber has 30 wt% MEA by adjusting MEA and water make-up flowrates. To achieve accurate predictions of the performance of the absorber and stripper units, the add-on amine thermodynamic package for UniSim was used throughout.

3. Suggested flow sheet modifications

Fig. 2 shows a conventional absorber/stripper amine process configuration. The CO₂ rich solvent is pumped and pre-heated to 100 °C by exchanging heat with the hot lean solvent exiting the stripper at 120 °C. The stripper operates at 193 kPa at the bottom with the reboiler operating at 120 °C. The reboiler is supplied with LP steam extracted from the IP/LP cross-over in the steam cycle as described above. The number of stages in absorber and stripper, which was later converted to the height of packed column equivalent to the number of stages, had been chosen so that the CO₂ rich and lean loadings (mol CO₂/mol MEA) can reach 0.492 and 0.231, respectively. These CO₂ loadings were so close to equilibrium limit imposed at the pressures that further increase in the number of stages (equivalent to the column height) could not improve the overall performance of amine process. The pressure drops along absorber and stripper were estimated by using Tray Sizing Utility in UniSim assuming they are packed with Flexipac 250Y and IMTP #40, respectively. They were around 3 kPa for both of them, which are consistent with those estimated by KG-Tower 5.1 (Koch-Glitsch, 2013). The flue gas exiting the absorber is sent to a water wash column where most of the vaporised MEA is abated and sent back to the absorber. The water and the recovered MEA from the water wash column are bled to the absorber. In addition, MEA make-up is injected to the lean amine stream in order to keep the MEA concentration in the solvent constant at 30 wt%. The recovered CO₂ from the stripper is compressed by a five-stage compression and intercooling system. Once the CO₂ stream becomes a dense phase at 7500 kPa, its pressure is boosted to the target pressure of 15,270 kPa by a pump. In this study, the thermal energy consumption in the stripper reboiler is estimated at around 3.5 MJ/kgCO₂ which is consistent with the values estimated in the references by either simulation or experiment (Desideri and Paolucci, 1999; Alie et al., 2005; Abu-Zahra et al., 2007; Fluor, 2003; Knudsen et al., 2007; Tobiesen et al., 2008; Karimi et al., 2011a). When this amine process is applied to a coal-fired power plant with a sub-critical steam cycle, this substantial energy consumption in the reboiler leads to around 12% drop of power plant efficiency (36.8% HHV to 24.9%) with a throttling valve (DOE, 2007a) and around 9% drop (36.8% HHV to 27.8%) with a let-down turbine as estimated in this work.

Cousins et al. (2011) reviewed sixteen different amine process configurations designed to reduce energy consumption and summarised their claims with respect to energy saving. From the study, however, it is difficult to compare the energy savings claimed in the patents and papers on a fair basis since they were evaluated with different solvents, different targets of acid gas removal (CO₂ or H₂S), or different operating conditions (pressure, temperature and feed composition). Some comparisons are based on experiments, others on process simulations. Therefore, it is worth studying the different process configurations given the same feed composition, solvent, operating condition and CO₂ capture rate. In this study, ten different amine process configurations shown in Figs. 2–11 have been simulated for the purpose of evaluating the conventional and improved amine processes.

- Conventional amine process (Fig. 2)
- Representative absorber intercooling configuration (Fig. 3)
- Condensate heating and evaporation configurations (Figs. 4 and 5)
- Stripper overhead compression configuration (Fig. 6)
- Lean amine flash configuration (Fig. 7)
- Multi-pressure stripping configuration (Fig. 8)
- Representative heat integration configuration (Fig. 9)
- Representative split-amine flow configuration (Fig. 10)

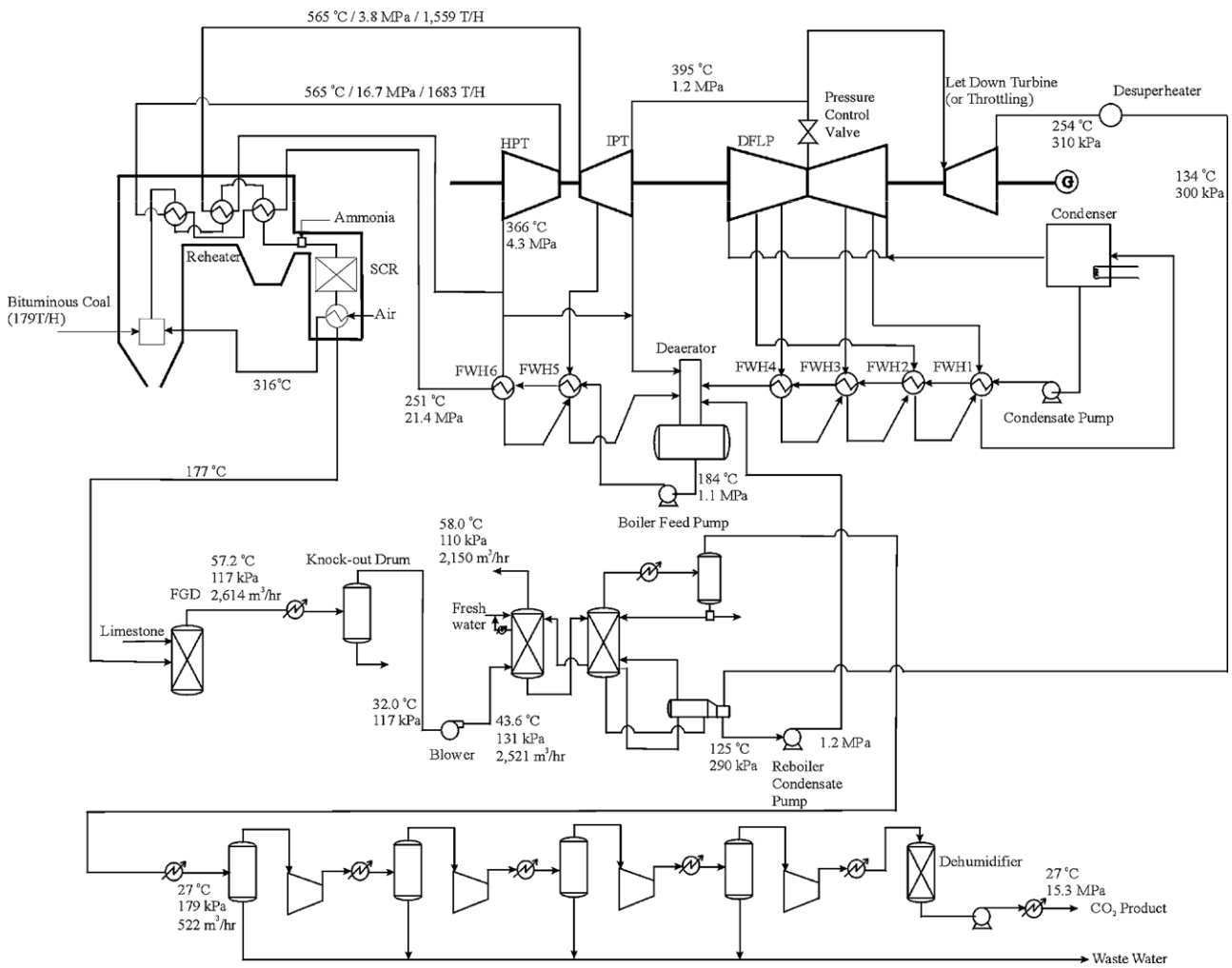

Fig. 1. Flowsheet of a sub-critical PC boiler power plant integrated with an amine process for carbon capture.

• Multiple alterations (Fig. 11)

We describe in detail each of these configurations and the effect that they have on the capture process performance as follows. Both pros and cons of each configuration are summarised in Table 1.

3.1. Absorber intercooling

Absorber intercooling is an efficient way of increasing the solvent working capacity resulting in the reduction in the required amount of circulating solvent and the size of equipment. Karimi

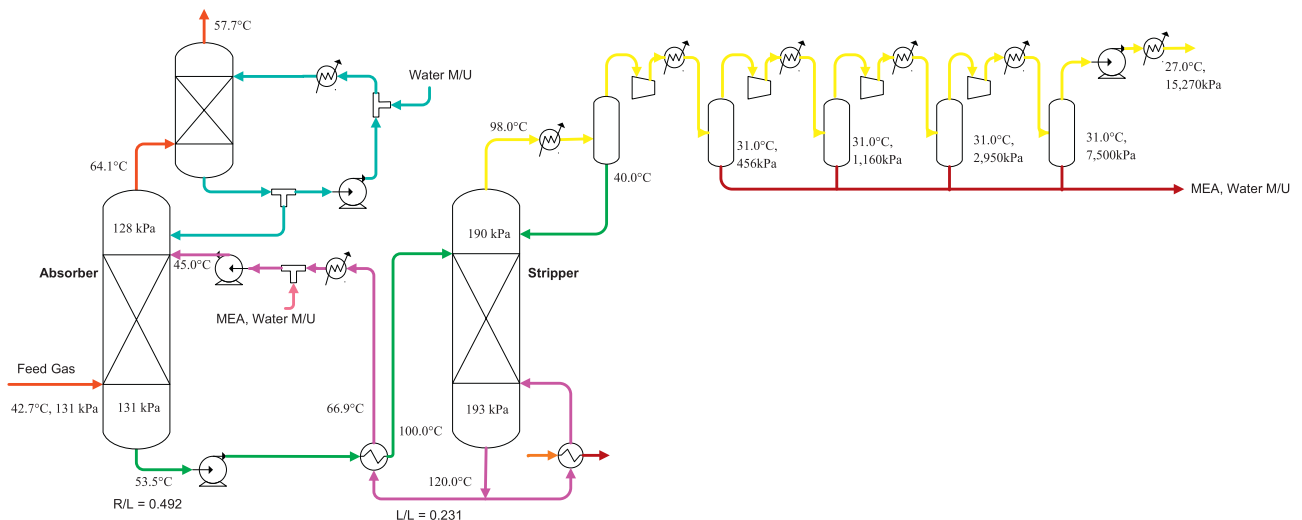

Fig. 2. Schematic diagram of conventional amine process.

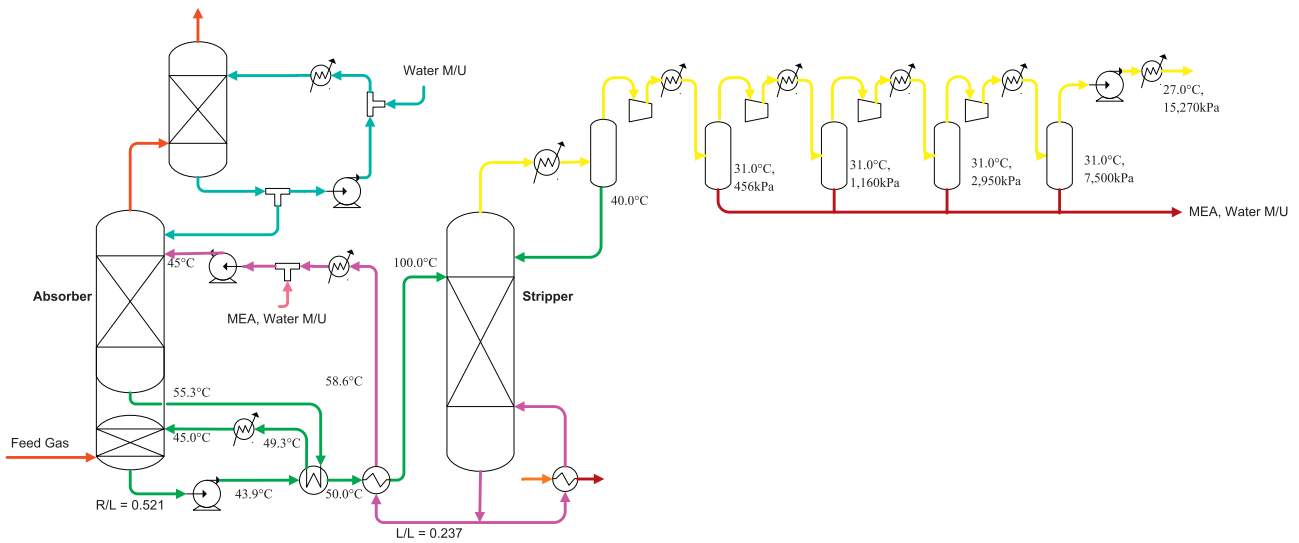

Fig. 3. Schematic diagram of 'absorber intercooling' case.

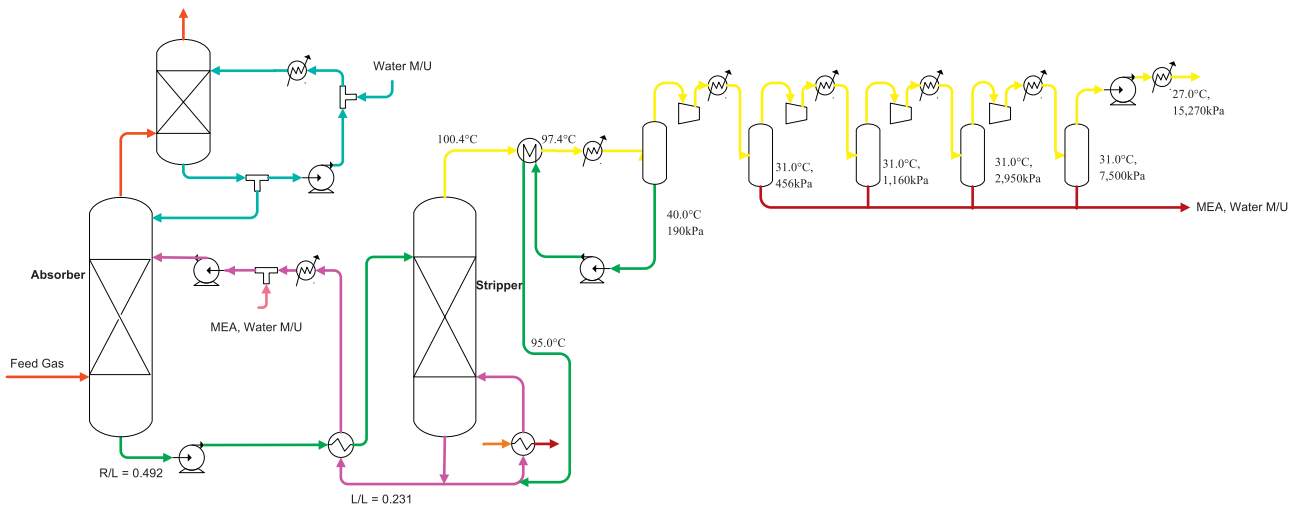

Fig. 4. Schematic diagrams of 'condensate heating' case.

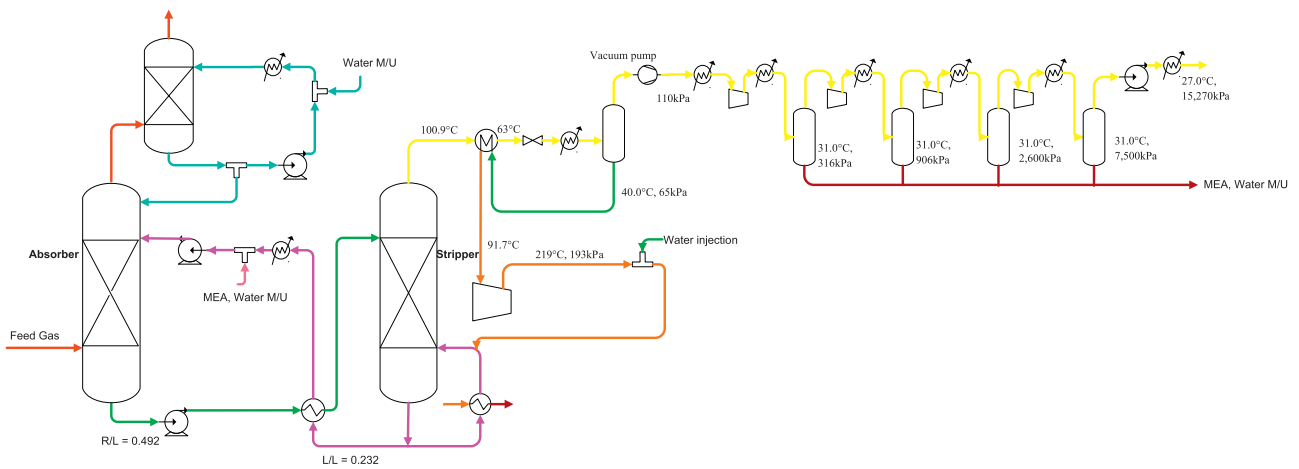

Fig. 5. Schematic diagram of 'condensate evacuation and evaporation' case.

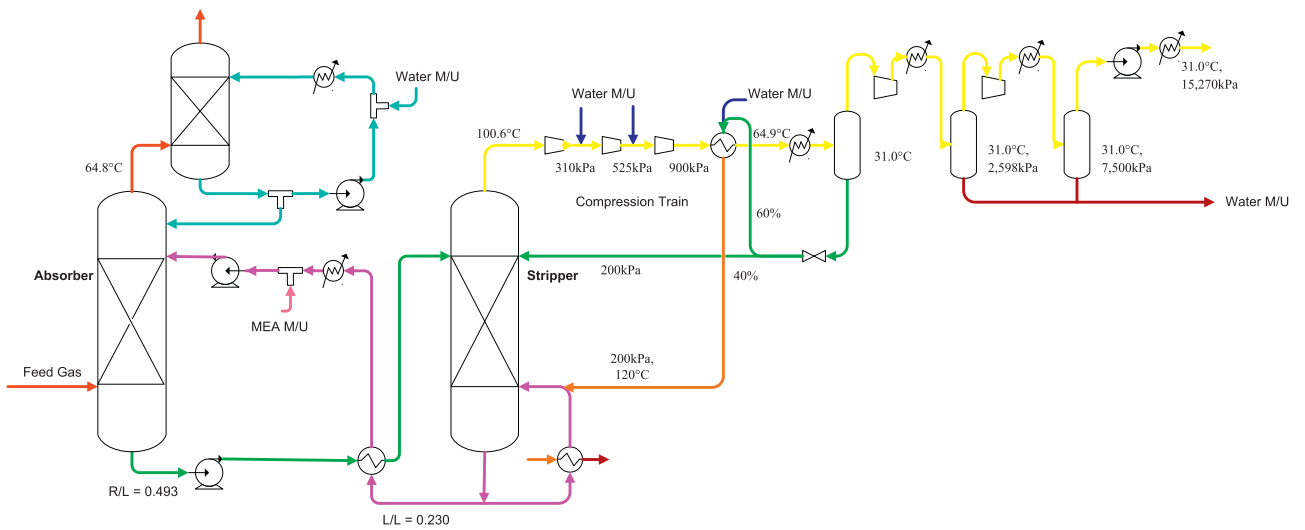

Fig. 6. Schematic diagram of 'stripper overhead compression' case.

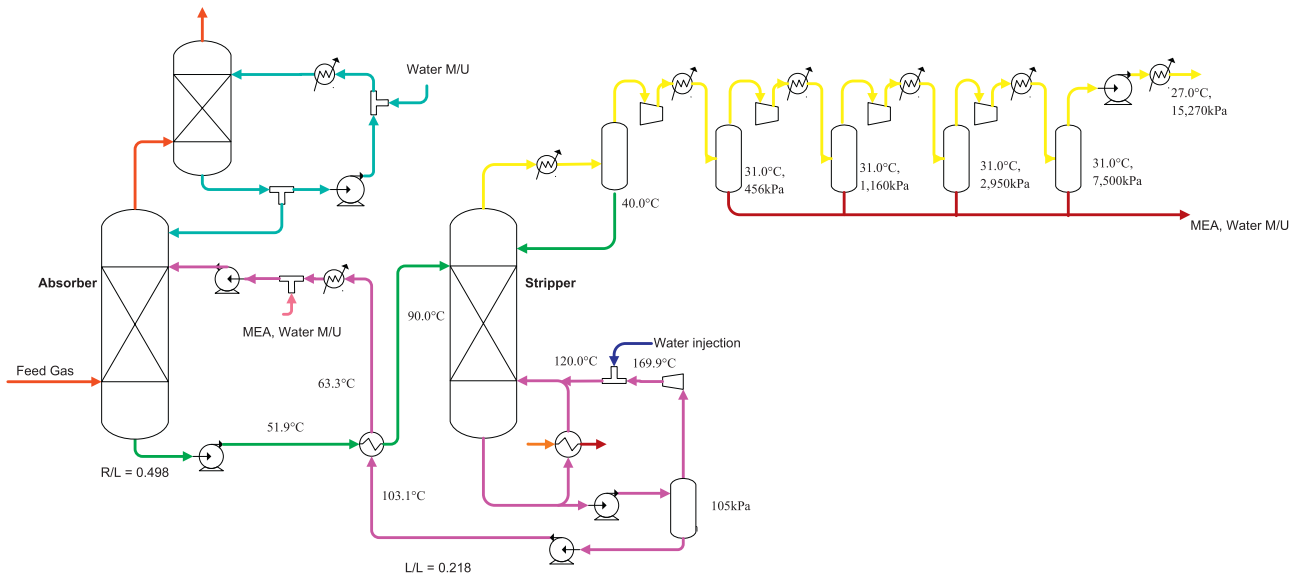

Fig. 7. Schematic diagram of 'lean amine flash' case.

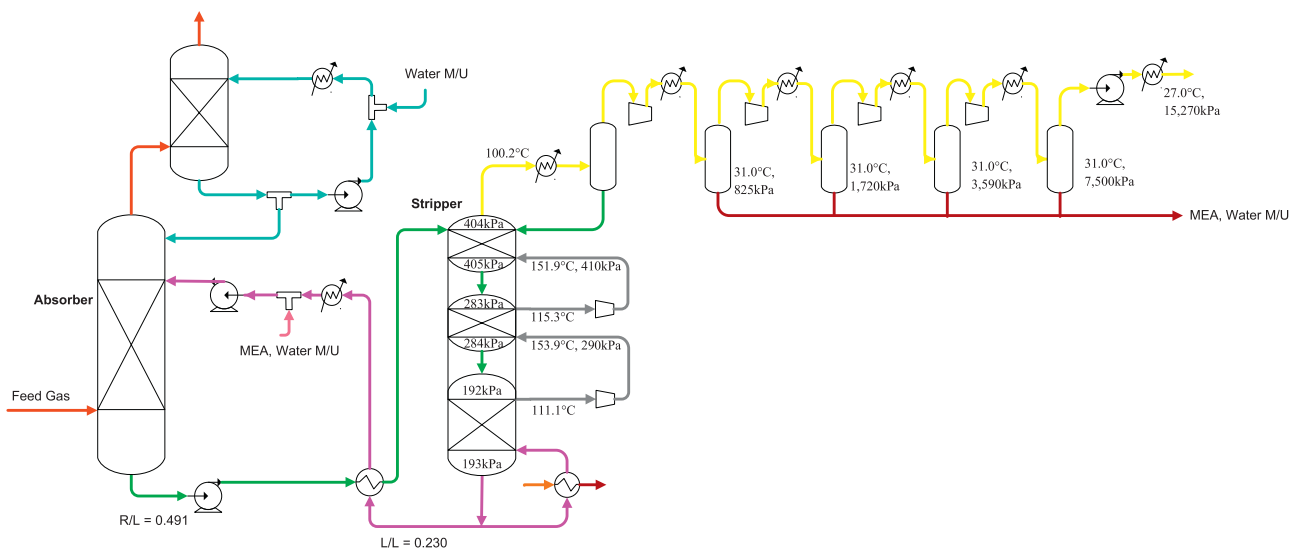

Fig. 8. Schematic diagram of 'multi-pressure stripping' case.

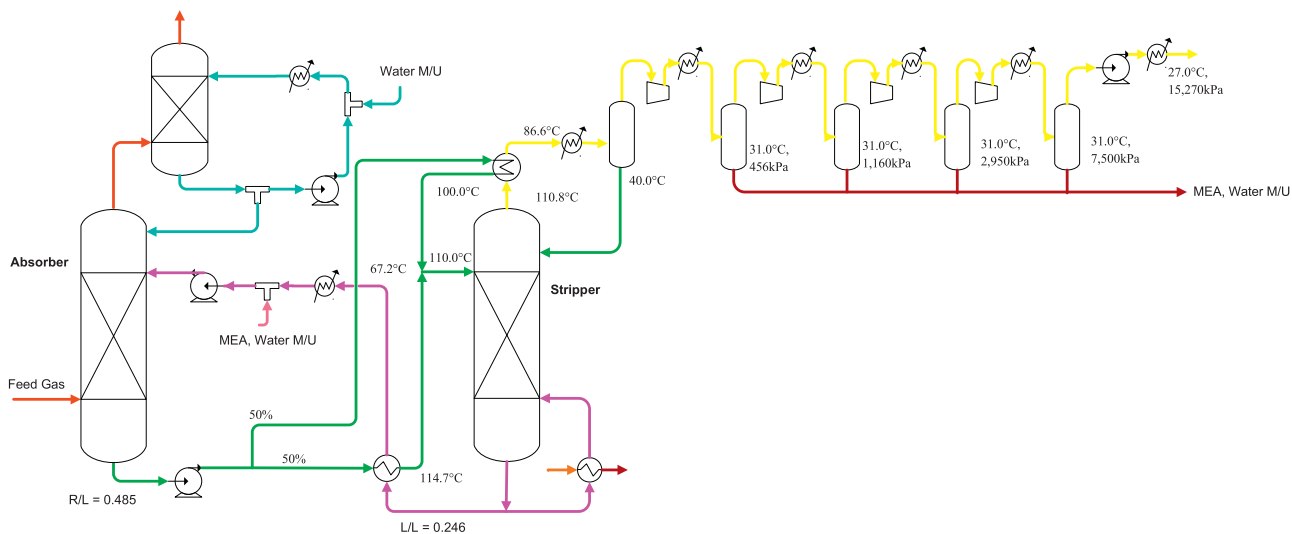

Fig. 9. Schematic diagram of 'heat integration' case.

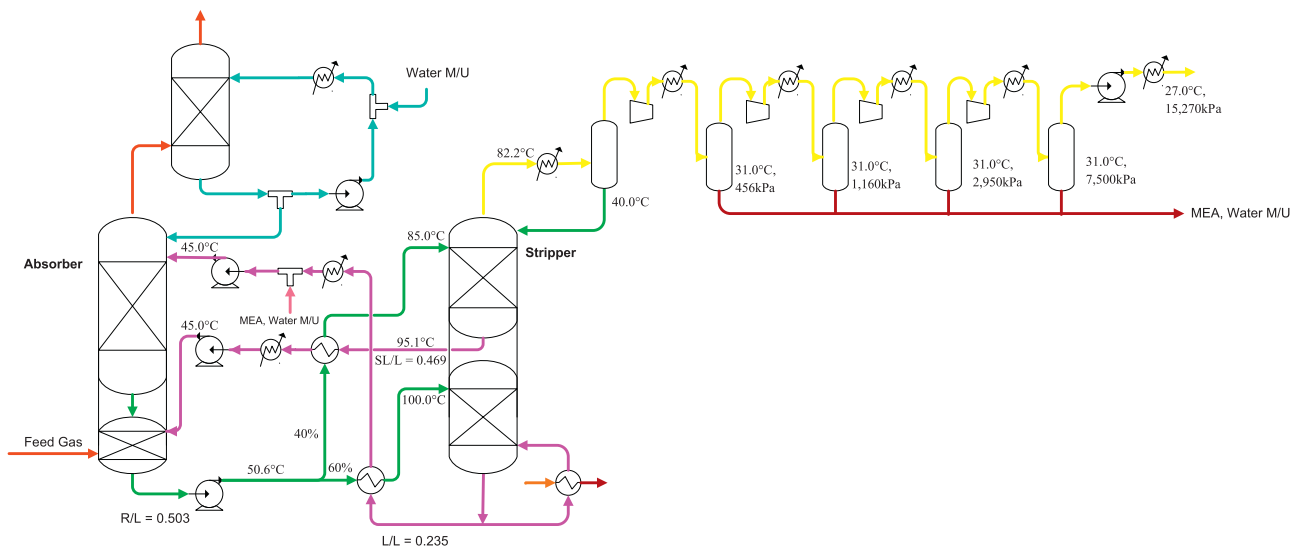

Fig. 10. Schematic diagram of 'split-amine flow' case.

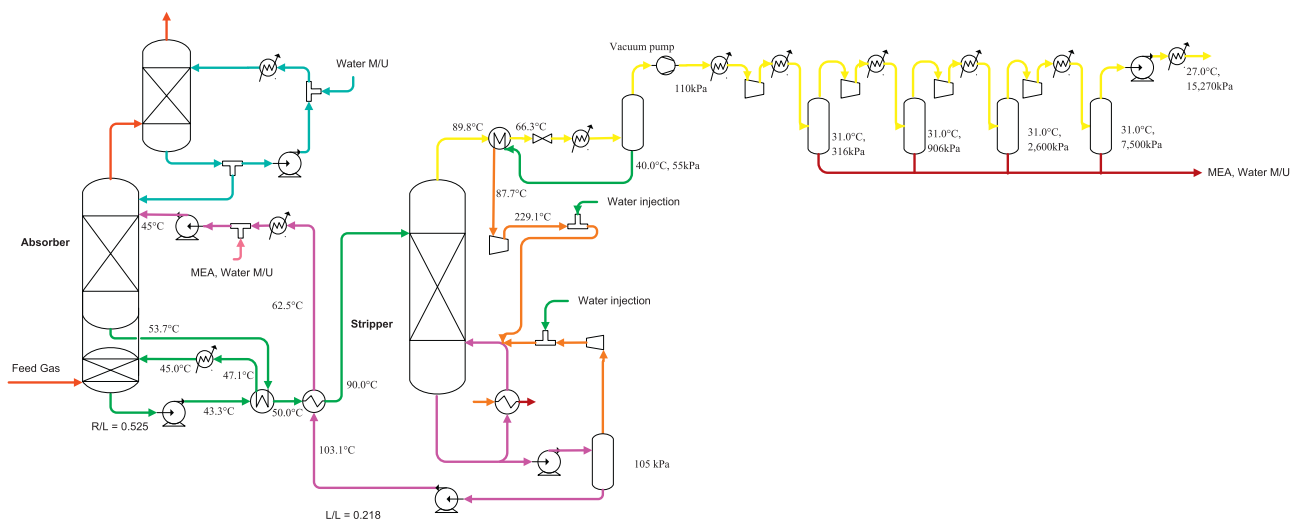

Fig. 11. Schematic diagram of 'multiple modifications (absorber intercooling, condensate evaporation and lean amine flash)' case.

Table 1
Summary of pros and cons of each amine process configuration.

Configuration	References	Pros	Cons
Conventional Absorber intercooling	DOE (2007a) Karimi et al. (2011b), Aroonwilas and Veawab (2007)	– Enhancing the solvent working capacity.	– –
Condensate heating	Aroonwilas and Veawab (2007)	Preheating of the condensate with stripper overhead stream.	Very marginal heat recovery.
Condensate evaporation	This work	Additional steam generation from the condensate by heat recovery from stripper overhead stream.	Increase of the electrical consumption due to condensate evacuation and steam compression. Higher CO ₂ product compression work.
Stripper overhead compression	Woodhouse (2008)	Recovery of CO ₂ compression heat by generating additional stripper steam through condensate evaporation.	Increase of the electrical consumption in the CO ₂ product compression up to the 3rd stage.
Lean amine flash	Reddy et al. (2009), Woodhouse and Rushfeldt (2008)	Additional steam generation by flashing the hot lean amine. Higher solvent working capacity.	Increase of the electrical consumption due to the flashed vapour compression. Lower stripper feed temperature.
Multi-pressure stripping	Oyenekan and Rochelle (2006), Liang et al. (2011)	Additional steam generation at lower pressure sections. Reduced CO ₂ compression work.	Increase of the electrical consumption due to the drawn-off vapour compression. Accelerating thermal amine degradation.
Heat integration	Herrin (1989)	Preheating of the stripper feed with the stripper overhead stream.	–
Split-amine flow	Kohl and Riesenfeld (1985)	Higher rich loading by absorber intercooling. More efficient use of stripper reboiler energy.	Lower overall solvent working capacity.
Multiple alteration (absorber intercooling + condensate evaporation + lean amine flash)	This work	Maximizing reboiler duty saving by simultaneous application of previous strategies.	Increase of the electrical consumption due to condensate evacuation, steam compression, and flashed vapour compression. Lower stripper feed temperature. Higher CO ₂ compression work.

et al. (2011b) investigated an intercooling effect in the amine capture process and found that the optimal location of intercooling in terms of minimum energy consumption lies about 1/4th–1/5th of the height of the column from the bottom. They claimed that 2.84% reboiler energy can be saved in case of MEA and 3.37% can be reduced with DEA compared to the conventional cases. Aroonwilas and Veawab (2007) also proposed an inter-stage cooling in which apparently the whole liquid collected from the bottom of upper section is drawn off the column, cooled, and returned to the top of lower section. As shown in Fig. 3, an amine process integrated with absorber intercooling has been simulated in order to evaluate the energy saving effect resulting from the enhanced solvent working capacity. In this study all the liquid is drawn off the column at the 1/5th of the column height from the bottom, cooled down to 45.0 °C and then returned to the lower section. It should be noted that the temperature of the CO₂ rich amine exiting the absorber would be lower due to solvent intercooling in Fig. 3 than that in Fig. 2. Therefore, the rich amine temperature is increased up to 50.0 °C by preheating it with the draw-off stream for intercooling. Using absorber intercooling, the rich loading increases up to 0.521 mol CO₂/mol MEA compared to 0.492 mol CO₂/mol MEA in conventional configuration while the lean loading is almost constant in both cases. This results in a reduction of 10% in the solvent required, which gives rise to an energy savings in the stripper reboiler roughly in proportion to the amount of amine solvent reduction as shown in Table 2.

3.2. Condensate heating

Aroonwilas and Veawab (2007) proposed a process design where the energy supplied to the reboiler can be recovered by preheating the condensate with the stripper overhead stream as shown in Fig. 4. Given the condition that the gas stream exiting the stripper has a temperature of around 100 °C, the condensate

can only be heated up to around 95.0 °C at most without phase change. The hot condensate, mainly water, is mixed with the stripper bottom flowing to the reboiler and then evaporated at 120 °C to supply steam. Therefore, it is hard to see a clear benefit from this configuration in terms of energy savings in the reboiler since most of the energy being consumed in the reboiler relates to the heat of evaporation. Under the condition of 5 °C hot temperature approach the temperature change in the stripper overhead stream across the heat exchanger is estimated to be only 3 °C, which indicates a very marginal heat recovery for this configuration.

3.3. Condensate evaporation

It is possible to improve this configuration by maximising heat recovery from the stripper overhead stream by evaporating the condensate rather than heating it as shown in Fig. 5. To do this, the condensate needs to be evacuated to 65 kPa at the knock out drum, a pressure determined by the stripper overhead temperature. Steam being generated at the heat exchanger by recovering heat from the stripper overhead has to be compressed to 200 kPa to prepare for its injection to the stripper. When compressed, the steam is heated up to more than 120 °C, the maximum temperature allowed to prevent thermal degradation of the solvent from occurring. Therefore, part of overall make-up water is injected to this superheated steam to obtain saturated steam. The steam generated by heat recovery from the stripper overhead is capable of reducing the load on the stripper reboiler by 26% as shown in Table 2. But it should be noted that additional equipment, such as vacuum pumps or ejectors, steam compression, and water injection, are required in this configuration and the energy saving in the reboiler is offset by electrical consumption in these additional units. However, it is clear that the extent of integration caused by steam extraction will be diminished.

Table 2
Simulation results on various amine process configurations.

Configuration	Rich loading (mol/mol)	Lean loading (mol/mol)	Reboiler duty (MJ _{th} /kgCO ₂)	Equivalent reboiler duty (MJ _e /kgCO ₂)	Reboiler duty saving (%)	CO ₂ compression work (MJ _e /kgCO ₂)	Amine/water pumps and blower work (MJ _e /kgCO ₂)	Additional work (compressors or vacuum pumps) (MJ _e /kgCO ₂)	Total energy consumption (MJ _e /kgCO ₂)	Total energy saving (%)
Conventional	0.492	0.231	3.52	1.056	-	0.270	0.054	0.000	1.380	-
Absorber intercooling	0.521	0.237	3.11	0.933	11.6	0.270	0.054	0.000	1.257	8.9
Condensate heating	0.492	0.231	3.53	1.059	-0.3	0.270	0.054	0.000	1.383	-0.2
Condensate evaporation	0.493	0.232	2.62	0.786	25.6	0.318	0.054	0.131	1.290	6.5
Stripper overhead compression	0.493	0.230	2.41	0.723	31.5	0.160	0.054	0.278	1.215	12.0
Lean amine flash	0.498	0.218	2.76	0.828	21.6	0.270	0.054	0.068	1.220	11.6
Multi-pressure stripping	0.492	0.232	3.17	0.951	9.9	0.208	0.058	0.136	1.353	2.0
Heat integration	0.485	0.246	3.10	0.930	11.9	0.270	0.054	0.000	1.254	9.1
Split-amine flow	0.503	0.235	3.09	0.927	12.2	0.270	0.055	0.000	1.252	9.3
Multiple alterations (absorber intercooling + condensate evaporation + lean amine flash)	0.525	0.218	2.22	0.666	36.9	0.318	0.054	0.147	1.186	14.1

3.4. Stripper overhead compression

Woodhouse (2008) suggested a new stripper design where the stripper vapour is compressed by 2–5 times the operating pressure of the stripper with water injected between compressors to make the stream saturated with water. The heat resulting from compression can be recovered by generating additional steam for the stripper reboiler, which gives rise to the reduction in the steam requirement from the external steam cycle. It was claimed that the steam requirement can be reduced by 24% (Woodhouse, 2008). In this study, the stripper vapour is compressed up to 900 kPa by three-stage compressors with water injection at each inter-stage and then additional LP steam is generated at a heat exchanger as shown in Fig. 6. To maximise the heat recovery at the heat exchanger, the water make-up flowrate flowing to the heat exchanger should be chosen such that the stripper overhead stream can be cooled down to around 65 °C after the heat exchanger. However, even though all the water make-up available is injected to the heat exchanger, it is not large enough to cool down the stripper overhead stream to 65 °C. In this work, therefore, the original configuration has been modified such that the condensate from the knock-out drum is split and 60% condensate flows to the heat exchanger to produce the additional steam for the stripper as shown in Fig. 6. The split ratio of condensate can be changed depending on the target pressure of the compression train. The total amount of water injection at the inter-stage and at the steam generator should be less than the required amount of total water make-up in the amine process otherwise the amine solvent would become more and more dilute during the operation. As a result of simulating this process, around 32% reduction in reboiler heat duty was achieved.

3.5. Lean amine flash

Reddy et al. (2009) and Woodhouse and Rushfeldt (2008) proposed a stripper design where additional steam can be generated by flashing the hot lean amine leaving the stripper at near-ambient pressure and then the gas stream is compressed up to the stripper pressure and re-introduced into the stripping column as shown in Fig. 7. When compressed, the flashed vapour is heated over 120 °C, so water injection is used to obtain saturated steam before feeding it to the stripper. Reddy et al. (2009) claimed a 13% increase in electrical power, 16% reduction in cooling water, 11% reduction in reboiler steam and 6% reduction in the stripper diameter. Woodhouse and Rushfeldt (2008) also claimed that this vapour recompression modification results in a 28% reduction in the steam requirement. It should be noted that the lean loading of the lean amine leaving the stripper is around 0.23 mol CO₂/mol MEA which is the same as the conventional process. This is further reduced by the flash since more CO₂ is desorbed by lowering the pressure in the flash drum. This results in the increase of solvent working capacity. However, the temperature of hot rich amine entering the stripper is set at 90 °C which is 10 °C lower in lean amine flash case than in the conventional process since the hot lean amine temperature is lowered from 120 °C to 103 °C by the flash. This lower rich amine temperature leads to an increase in the energy consumption in the stripper and as a result offsets the energy saving effect induced by both additional steam generation and improved working capacity. In this simulation, around 22% of the reboiler energy was saved with this configuration.

3.6. Multi-pressure stripping

Oyeneke and Rochelle (2006), followed by Rochelle (2011) and Liang et al. (2011), proposed a multi-pressure stripper design which is similar to the configuration presented in Fig. 8. This configuration

has a clear advantage over the conventional scheme, in that it can reduce both the steam consumption in the stripper reboiler and the compression work. The stripping column has three sections, which are designed so that the section above their lower section operates at a higher pressure. The section at the bottom of the stripper runs at the same pressure (193 kPa) as the conventional scheme. In this study, the bottom pressures at the top and middle sections are set 405 kPa and 284 kPa, respectively so that the stripper design has the same compression ratio of around 1.45 between stages as used in the earlier study by Oyenekan and Rochelle (2006). The mixture of steam and acid gas exiting the top of a lower section is compressed up to the pressure at the upper section and then used as the stripping gas for the upper section. When the rich solvent flows from an upper section to its lower section, it is flashed to generate additional steam which is added to the steam generated at the reboiler. The liquid stream flowing to the lowest section of the stripper contains lower CO₂ and is at higher temperature (113.1 °C) than that in the conventional stripper, which leads to a reduction in the stripper reboiler energy. Since the CO₂ product leaving the stripper is at a higher pressure, less energy is required for compression up to the target pressure. Oyenekan and Rochelle (2006) also claimed that the reboiler duty can be reduced by 20% at the same rich CO₂ partial pressure at the top of absorber as used in this study. They also claimed that an 8% saving in total equivalent work can be made compared to the conventional case. In this work, 10% reduction in reboiler energy and 2% reduction in total equivalent work have been estimated. This discrepancy may be due to use of the different amine solvent (around 42 wt% in Oyenekan and Rochelle compared to 30 wt% in this study) and different pressure at the bottom of stripper (160 kPa in Oyenekan and Rochelle and 196 kPa in this study). In addition, the performance is greatly influenced by the efficiency of compressors for compression of drawn-off vapours. It should be noted that as the steam generated by flash may exceed 120 °C when compressed, the rate of thermal amine degradation may be accelerated with this configuration.

3.7. Heat integration

In general, if the stripper feed enters the stripper at a higher inlet temperature a lower heat duty in the stripper reboiler would be required. However, there exists a maximum temperature of a hot rich amine which cannot be exceeded. The maximum temperature is subject to both the temperature of the hot lean amine as heating medium and both hot and cold minimum temperature approaches of the heat-exchanger, which are set a priori. However, the restriction imposed on the rich amine temperature can be overcome by a more efficient heat recovery from the stripper as shown in Fig. 9. As suggested by Herrin (1989), the cold rich amine is split into two streams by half and then one half flows to an additional heat-exchanger where it is heated by the stripper overhead stream while the other half is preheated by the hot lean amine as usual. When the two streams are combined after pre-heating, the resulting stream can reach a higher temperature than that in the conventional process due to the enhanced heat recovery. It was claimed that 35% of the reboiler duty can be reduced by this process in the patent (Herrin, 1989). In this study, it is estimated that the hot rich amine after the Lean/Rich amine heat-exchanger can reach around 115 °C by reducing the flowrate, assuming the temperature of the lean amine leaving the heat exchanger is around 67 °C which is same in both cases. It is assumed that the temperature of the other rich amine stream can be increased to 100 °C given the 111 °C of the stripper overhead stream. As a result, the combined hot rich amine stream is 10 °C higher in this improved process than that in the conventional process leading to around 12% cut in reboiler energy. It also implies that the temperature of a stripper overhead stream entering the cooler can be regarded as an index to indicate how

well the energy input to the reboiler is used in the process. This point will be revisited in the split-amine flow process below.

3.8. Split-amine flow

A split-amine flow process originated from the patent by Shoeld (1934) aiming to remove H₂S from fuel gases using sodium phenolate. Since then, a variety of split-amine flow processes have been proposed (Geleff, 2004; Towler et al., 1997; Reddy et al., 2005; Mak, 2008; Won et al., 2003). One feature that these processes have in common is a semi-lean amine stream which is characterised by being regenerated to a less extent than the lean amine. The semi-lean is in most cases drawn off the middle of the stripper but it can also be generated in a separate stripping column which operates at a moderate condition compared to the stripper (Reddy et al., 2005). In the split-amine process by Mak (2008), the regenerated amine leaving the stripper is split into two streams: one enters the absorber as a lean amine and the other flows to the separate stripping column for further regeneration to obtain a leaner amine. The semi-lean is always fed to the absorber in the middle to cool down the absorber temperature. The performance in the split-amine process can be improved further by adding an additional reboiler for semi-lean stripping (Towler et al., 1997) or cooling down the absorber semi-lean as well as the regenerator semi-lean (Won et al., 2003) but the energy saving effects mainly come from the semi-lean flow configuration itself. In this study, a typical amine process (Kohl and Riesenfeld, 1985) representing split-amine processes has been simulated as shown in Fig. 10. The absorber with intercooling by the semi-lean flow can operate at a higher CO₂ rich loading (0.503 mol CO₂/mol MEA) and the rich amine exiting the absorber is split into two, with the split ratio of 60% (lean) to 40% (semi-lean). Since the semi-lean section is operated at a lower temperature, the stripper overhead stream exiting the stripper is estimated to be at around 82 °C. This means a more efficient use of the reboiler energy in the split-amine flow than in the conventional process. This implies that the total energy consumption can be minimised by keeping the temperature at the top of the stripper as low as possible maximising recovery of the reboiler heat. This design concept can also be found in the patent by Eisenberg and Johnson (1979) where the un-heated portion of rich amine is fed to the top of the stripper without pre-heating to maximise the reboiler heat recovery. In this work, about 12% reduction of reboiler duty has been estimated from the results of the process simulation of the representative split-amine process. The required amount of circulating solvent is larger in the split-amine flow configuration than in the conventional process since the average solvent working capacity is lowered due to the lower extent of amine regeneration. This means that it would require higher CAPEX since all the equipments would be larger roughly in proportion to the increase in solvent flowrate.

3.9. Multiple alterations

In order to reduce the energy requirement in the stripper reboiler further, it is possible to apply several strategies at the same time and develop configurations of amine processes as shown in Fig. 11. Here absorber intercooling, lean amine flash and condensate vaporisation are applied simultaneously. The condensate needs to be depressurised to 55 kPa for its evaporation compared to 65 kPa in Fig. 5 since the gaseous stream exiting the stripper is colder than in the amine process with condensate vaporisation, due to the colder rich amine entering the stripper. As the lean amine becomes colder when flashed, the maximum temperature of rich amine to be reached in the lean/rich exchanger will be 10 °C lower. The lower temperature of the hot rich amine will increase the steam usage in the reboiler and the lower pressure at the stripper condenser will

Table 3
Comparison of performance of PC-boiler power plants without and with carbon capture.

	Power plant without carbon capture		After retrofit (90% carbon capture)	
	DOE (2007a) – subcritical PC case	This simulation	Base case simulation	Multiple alteration case simulation
Required reboiler duty (MJ _{th} /kg _{CO₂})	N/A	N/A	3.52	2.22
Heat input, HHV (MW _{th})	1496	1496	1496	1496
Gross power (MW _e)	591.9	594.1	497.3	533.4
HP turbine	159.9	161.5	161.5	161.5
IP turbine	144.4	144.8	144.8	144.8
LP turbine ^a	287.6 ^b	287.8	139.0	194.4
Let down turbine	–	–	52.0	32.7
Percentage of steam extraction flow to total IP/LP crossover flow	–	–	49%	31%
CO ₂ Compression power (MW _e)	–	–	31.8	37.5
Generator loss (MW _e)	8.6	8.6	8.6	8.6
Auxiliary power (MW _e)	32.9	32.9	39.2	56.3
Net plant power (MW _e)	550.4	552.6	417.7	431.0
Net plant efficiency (HHV basis)	36.8%	36.9%	27.9%	28.8%

^a The power generation at LP turbine excludes power generated by Boiler Feed Pump Turbine Drive.

^b The steam condition of the LP turbine exhaust is not shown in the DOE report while the conditions of all the steams extracted from the LP turbine are known. Therefore, the power generation relating to LP turbine exhaust was estimated by deducting from the gross power the sum of HP and IP turbine powers, BFW pump turbine drive power, and power generation in relation to steam extraction at the LP turbine.

lead to a larger consumption of electricity in the associated vacuum pump and steam compressor. This implies that the amount of saving in steam use in Fig. 11 is not simply a sum of those estimated at each improved amine process found in Figs. 3, 5 and 7 and a rigorous estimation of the resulting energy saving effect needs an independent flowsheet simulation of the process as implemented in this study. As a result, the improved amine process with the multiple measures can reduce the reboiler energy by around 37%, when compared to the conventional process.

4. Total energy consumption

Most amine process configurations investigated in this study has different electricity consumption resulting from auxiliary units as well as different thermal energy consumption at the stripper. Therefore, it is essential to investigate the total energy consumption in each amine process and have an overall basis for comparison.

In this study, the total energy consumption at each scheme is expressed in terms of electrical energy. Therefore, the thermal energy in the stripper reboiler needs to be converted to its equivalent electricity following Eq. (1).

$$\eta = \frac{\dot{W}_{\text{Ideal}}}{\dot{Q}} \cdot \eta_{\text{ad}} \quad (1)$$

where \dot{W}_{Ideal} is the adiabatic turbine work per unit of mass (kJ/kg), \dot{Q} is the heat flow rate to the system per unit of mass (kJ/kg), and η_{ad} is turbine adiabatic efficiency. It is well-known that the entropy change in a turbine is negligible (Smith et al., 2005), therefore the assumption of an adiabatic expansion gives the ideal work for an isentropic process from a superheated steam at 254 °C and 310 kPa to a two phase stream at 10.3 kPa. Thereafter the ideal work was corrected to the actual work taking into account the turbine adiabatic efficiency of 0.95, which enabled us to estimate an actual enthalpy at the exit of the turbine. The resulting conversion factor (η) calculated by Eq. (1) is 0.30. Note that the turbine adiabatic efficiency, 0.95, used for this turbine is much higher than the well-known number (0.86; Kadambi and Prasad, 1977) because around 10% liquid fraction in LP exhaust stream would be permitted in this case.

As well as the change in thermal energy for the reboiler stripper, electricity consumption in the auxiliary units, such as solvent pump and CO₂ compressor train, varies with the modification of the process. Moreover, in cases where either a gas compressor or a

vacuum pump or both are added, the work in the vacuum pump or compressor is estimated by

$$W = \frac{F \cdot R \cdot T_1 \cdot (\gamma/(\gamma - 1)) \cdot [(P_2/P_1)^{(\gamma-1)/\gamma} - 1]}{\eta_{\text{ad}}} \quad (2)$$

where F is gas flowrate (mol/s), R is gas constant (J/mol/K), T_1 is inlet temperature (K), γ is volume exponent, P_1 and P_2 are inlet and outlet pressure of the vacuum pump or compressor, and η_{ad} is the adiabatic efficiency of the vacuum pump or compressor. For example, in case of a vacuum pump, γ is around 1.27, P_2 is 110 kPa, P_1 is 65 kPa in Fig. 5 and 55 kPa in Fig. 11.

The thermal and electrical energy consumptions evaluated by the simulation of each case are shown in Table 2. All the flowsheets, apart from the condensate heating case, exhibit lower steam usage in the range of 10–37%. The CO₂ compression work varies over the different processes depending on the pressure of the CO₂-rich stream discharged from the stripper. In the two cases (Figs. 5 and 11) with a vacuum pump, the CO₂-rich stream at the outlet of the vacuum pump is considered to be at ambient pressure, while in the base case the gas is generated at 193 kPa. In contrast, the stripper overhead compression case and the multi-pressure stripping case can produce a CO₂-rich stream at higher pressures.

Flowsheets where new compressors or vacuum pumps are added will consume additional electricity. In particular, the steam saving effect in both condensate overhead compression and multi-pressure stripping are greatly offset by the additional electricity consumption in the compressors. The rich amine solvent pump also requires electricity and its energy consumption is determined by both the flowrate of circulating amine and pressure difference of the absorber and stripper. As the multi-pressure stripper operates at 397 kPa, as the highest pressure at the top section, compared to 190 kPa in the other cases, it shows the largest electricity consumption in the rich amine pump. In the split-amine flow case, the amount of circulating solvent is greater than even that in the base case since the working capacity of the solvent is lower. This leads to a larger pump work. In the lean amine flash, a slightly higher pumping work for lean amine pump was estimated due to the lower pressure of the lean amine after flash but this effect was offset by a lower rich amine pump work.

As expected, the total energy saving is lower than the reboiler duty savings due to the additional electricity consumption in the auxiliary units in most cases. Nevertheless, it is evident from the detailed process simulation results that the total energy

consumption can be reduced significantly by the use of improved amine process configurations.

5. Integration of the power plant with the amine process

The simulation results of PC-fired boiler power plant without and with integration with an amine process are shown in Table 3. The simulation result of existing power plant before retrofit was reconstructed based on the process design in case 9 of DOE report (DOE, 2007a). When integrated with a conventional amine process (Fig. 2), around 49% of IP/LP crossover needs to be routed to the amine stripper to provide the required regeneration heat duty, leading to 9.0% of the net plant efficiency drop. In retrofit cases, the LP steam flowing to Boiler Feed Pump Turbine Drive (not shown in Fig. 1) has same flowrate as in the conventional case since same power would be required for BFW pumping. But the flowrates of the various LP turbine exhaust streams cannot be same over the configurations due to the different extent of required steam extraction but the flow ratios of those streams were kept constant. This way of design could maintain the temperature of the hot BFW entering the deaerator around 140 °C regardless of the extent of steam extraction. The IP turbine exhaust pressure would not change despite the steam extraction since it can be maintained by installing a pressure control valve as shown in Fig. 1 (DOE, 2007b). Furthermore, it is assumed that, in case of part-load steam turbine operation, the power generation at LP turbine would be linearly proportional to steam flowrate using same turbine adiabatic efficiency. Compared to the conventional amine process, the power plant integrated with the multiple alteration case (Fig. 11) requires only 31% steam extraction but more electricity consumption for vacuum pump, compressors, and CO₂ compression. In overall, it is estimated that the net plant efficiency can be increased by 0.9% only by improving the amine process configuration with same 30 wt% aqueous MEA solvent.

6. Conclusions

Ten different process flowsheets have been simulated on the same basis of flue gas temperature, pressure, and composition. In addition, all simulations have been constrained so that the hottest temperature of the amine solution is maintained below 120 °C, thus avoiding amine thermal degradation. The use of the same basis allows direct comparisons between the configurations in terms of reductions in overall energy penalty, use of steam and electricity. The comparisons include the compression train, which is affected by some advanced solutions for the stripper aimed at reducing the final compression energy. Various configurations may be optimal for different retrofit conditions and the results reported should allow rapid initial assessments that can then be tailored to the particular power plant.

It has been shown that a reduction of up to 37% can be achieved for the best configuration in terms of the amount of LP steam required. The saving in thermal energy consumption is mainly due to enhanced heat recovery, increased solvent working capacity, or alternative steam generation by either evacuation or compression. It is found that each process consumes less thermal energy than the conventional one but requires additional use of electricity in compressors and pumps and also produces CO₂ product at different pressures.

We proposed a new concept of amine process design having multiple strategies applied where the heat duty in the stripper is as low as around 2.22 MJ/kg CO₂ which can be significant reduction considering that in conventional process (3.52 MJ/kg CO₂) and an overall energy penalty of only 8.1%, compared to 9.0% of the conventional amine absorber and stripper configuration.

Acknowledgments

We would like to express our gratitude for the financial support from EPSRC (Grants No.: EP/F034520/1 and EP/G062129/1) and KETEP (Grant No.: 2011-8510020030).

References

- Abu-Zahra, M.R.M., Schneiders, L.H.J., Niederer, J.P.M., Feron, P.H.M., Versteeg, G.F., 2007. CO₂ capture from power plants. Part I. A parametric study of the technical performance based on monoethanolamine. *International Journal of Greenhouse Gas Control* 1 (1), 37–46.
- Alie, C., Backham, L., Croiset, E., Douglas, P.L., 2005. Simulation of CO₂ capture using MEA scrubbing: a flowsheet decomposition method. *Energy Conversion & Management* 46 (3), 475–487.
- Aroonwilas, A., Veawab, A., 2007. Heat recovery gas absorption process. Patent No. WO 2007/107004 A1.
- Cormos, A., Gaspar, J., 2012. Assessment of mass transfer and hydraulic aspects of CO₂ absorption in packed columns. *International Journal of Greenhouse Gas Control* 6, 201–209.
- Cousins, A., Wardhaugh, L.T., Feron, P.H.M., 2011. A survey of process flow modifications for energy efficient CO₂ capture from flue gases using chemical absorption. *International Journal of Greenhouse Gas Control* 5 (4), 605–619.
- DECC ScottishPower CCS Consortium, 2011. UK Carbon Capture and Storage Demonstration Competition, SP-SP 6.0-RT015 FEED Close Out Report (http://www.decc.gov.uk/en/content/cms/emissions/ccs/ukccscomm_prog/feed/scottish.power/scottish.power.aspx as of 15/12/2012).
- Desideri, U., Paolucci, A., 1999. Performance modelling of a carbon dioxide removal system for power plants. *Energy Conversion & Management* 40, 1899–1915.
- DOE/NETL-2007/1281, 2007a. Cost and performance baseline for fossil energy plants. Volume 1: bituminous coal and natural gas to electricity final report.
- DOE/NETP-401/110907, 2007b. Carbon dioxide capture from existing coal-fired power plants.
- Eisenberg, B., Johnson, R.R., 1979. Amine regeneration process. US Patent 4,152,217 A1.
- Fluor, 2003. Fluor's Econamine FG PlusSM technology: an enhanced amine-based CO₂ capture process. In: Second National Conference on Carbon Sequestration, NETL/DOE.
- Geleff, S.A., 2004. Method for recovery of carbon dioxide from a gaseous source. Patent No. WO 2004/073838 A1.
- Herrin, J.P., 1989. Process sequencing for amine regeneration. US Patent 4,798,910.
- IEAGHG, 2011. Retrofitting CO₂ capture to existing power plants.
- Kadambi, V., Prasad, M., 1977. An Introduction to Energy Conversion: Turbomachinery. NewAge International, vol. 3.
- Karimi, M., Hillestad, M., Svendsen, H.F., 2011a. Capital costs and energy considerations of different alternative stripper configurations for post combustion CO₂ capture. *Chemical Engineering Research and Design* 89 (8), 1229–1236.
- Karimi, M., Hillestad, M., Svendsen, H.F., 2011b. Investigation of inter-cooling effect in CO₂ capture energy consumption. *Energy Procedia* 4, 1601–1607.
- Koch-Glitsch, 2013. KG-Tower 5.1, <http://www.koch-glitsch.com/software/default.aspx> as of 18/02/2013.
- Kohl, A.L., Riesenfeld, F.C., 1985. Gas Purification, 4th ed. Gulf Publishing Company.
- Knudsen, J.N., Jensen, J.N., Vilhelmsen, P.-J., Biede, O., 2007. First Year Operation Experience with a 1 t/h CO₂ Absorption Pilot Plant at Esbjerg Coal-Fired Power Plant. In: Proceedings of European Congress of Chemical Engineering (ECCE-6), Copenhagen, Denmark.
- Liang, H., Xu, Z., Si, F., 2011. Economic analysis of amine based carbon dioxide capture system with bi-pressure stripper in supercritical coal-fired power plant. *International Journal of Greenhouse Gas Control* 5, 702–709.
- Mak, J., 2008. Configurations and methods for acid gas absorption and solvent regeneration. US Patent 2008/0184887 A1.
- Oyekan, B.A., Rochelle, G.T., 2006. Energy performance of stripper configurations for CO₂ capture by aqueous amines. *Industrial & Engineering Chemistry Research* 45, 2457–2464.
- Puxty, G., Rowland, R., Allport, A., Yang, Q., Bown, M., Burns, R., Maeder, M., Attalla, M., 2009. Carbon dioxide postcombustion capture: a novel screening study of the carbon dioxide absorption performance of 76 amines. *Environmental Science & Technology* 43, 6427–6433.
- Reddy, S., Gilmartin, J., Francuz, V., 2009. Integrated compressor/stripper configurations and methods, US Patent 2009/0205946 A1.
- Reddy, S., Scherffius, J., Gilmartin, J., Freguia, S., 2005. Improved split flow apparatus. EP 1 551 532 B1.
- Rochelle, G.T., 2011. Regeneration of an aqueous solution from an acid gas absorption process by multistage flashing and stripping. US Patent 7,901,487 B2.
- Shoeld, M., 1934. Purification and separation of gaseous mixtures. US Patent 1,971,798.
- Simon, L.L., Elias, Y., Puxty, G., Artanto, Y., Hungerbuhler, K., 2011. Rate based modelling and validation of a carbon-dioxide pilot plant absorption column operating on monoethanolamine. *Chemical Engineering Research and Design* 89, 1684–1692.

- Smith, J.M., Van Ness, H.C., Abbott, M.M., 2005. *Introduction to Chemical Engineering Thermodynamics*, 7th ed. McGraw Hill International.
- Tobiesen, F.A., Juliussen, O., Svendsen, H.F., 2008. Experimental validation of a rigorous desorber model for CO₂ post-combustion capture. *Chemical Engineering Science* 63 (10), 2641–2656.
- Towler, G.P., Shethna, H.K., Cole, B., Hajdik, B., 1997. Improved absorber-stripper technology for gas sweetening to ultra-low H₂S concentrations. In: *Proceedings of the 76th GPA Annual Convention*, Tulsa, OK, pp. 93–100.
- Won, R., Condorelli, P., Scherffius, J., Mariz, C.L., 2003. Split-flow process and apparatus. US Patent 6,654,446 B1.
- Woodhouse, S., 2008. Improved absorbent regeneration. Patent No. WO 2008/063082 A2.
- Woodhouse, S., Rushfeldt, P., 2008. Improved absorbent regeneration. Patent No. WO 2008/063079 A2.
- ZEP (Zero Emissions Platform), 2010. *The costs of CO₂ capture: post-demonstration CCS in the EU*.