

## Fatigue of Steel Plates with Inclusions

Mieczysław JARONIEK

*Department of Strength of Materials  
Lodz University of Technology  
Stefanowskiego 1/15, 90–924 Łódź, Poland*

Tadeusz NIEZGODZIŃSKI

*Department of Mechanics and Mechanical Engineering  
Higher Vocational State School  
3 Maja 17, 87-800 Włocławek, Poland*

Received (10 September 2015)

Revised (5 November 2015)

Accepted (20 December 2015)

Manufactured by the end of the 80s in the last century steel structures were made of steel which contain significant amounts of non-metallic inclusions. As a result of many years of intensive use of the structures made of steel, structural discontinuity material combine to form internal cracks called lamellar cracks.

These cracks are formed in rolled sheets with non-metallic inclusions. Studies of lamellar cracks began in the 1960s, but there is still no satisfactory theory explaining their formation.

*Keywords:* fatigue test, girder crane, non-metallic inclusions.

### 1. Introduction

As part of this work there were performed strength tests on samples howl-the sheet metal girder crane built around 1950 in a steel mill operated until 2009. Girder earmarked for scrap and it was possible to carry out experimental material structure. Fragments of metal were excised from belts of dollars–beam (Fig. 1).

A crane load causes changes in stress in the lower flange of the girder from zero to maximum (a pulsating positive).

The estimated number of cycles for crane we assume that the gantry carries a full load for which it was designed: 5 times per hour, 24 hours of work per day, 365 days a year.

The number of load cycles during 10 years of operation. These are the results:  
 $N_1 = 5 \cdot 24 \cdot 365 \cdot 10 = 438000 \approx 4 \cdot 10^4$ .

In 50 years of operation  $N_2 \approx 5 \cdot 4 \cdot 10^4 \approx 2 \cdot 10^5$  cycles.

As a result of flaw detection of magnetic and ultrasonic testing had stopped—no locus of numerous zones of non-metallic inclusions and places of deprivation—down defects.

With selected zones were cut by laser cutting samples for testing solid-cal and fatigue (Fig. 2).

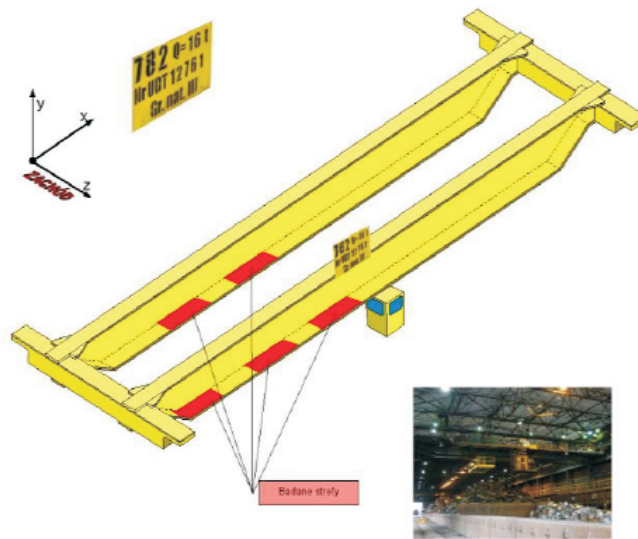

**Figure 1** Bridge crane to the area sampling for analysis

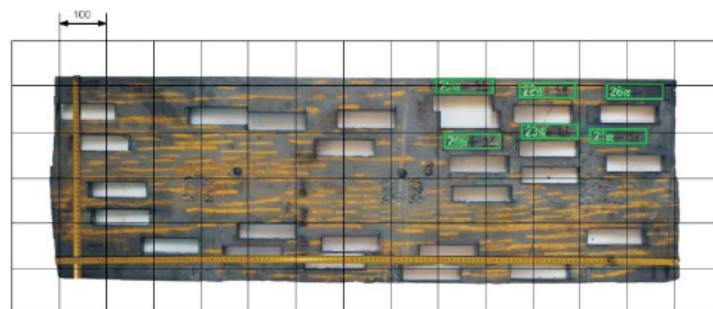

**Figure 2** The view of the bottom sheet after cutting out test specimens

## 2. Experimental results

Evaluation of strength of the gired was carried out in the Laboratory of Strength University of Mining – Metallurgy (AGH) in Krakow [1].

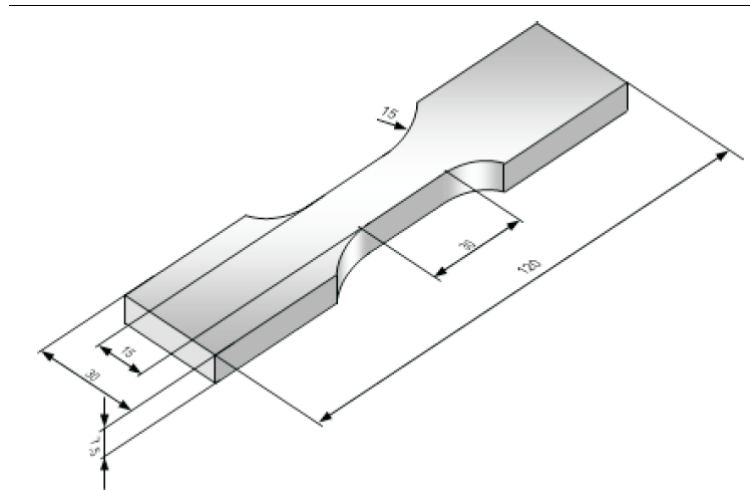

**Figure 3** The dimensions of the samples taken for testing

The shape and dimensions of the samples used in the study are shown in Fig. 2. As a result of experiments - the static tensile test - to yield material properties of the steel used to build a bridge crane of the test sample; These values differ significantly from the nominal data (of code) for steel St3S. The data are summarized in the following table.

**Table 1** Material properties

| material                       | $R_e$ [MPa] | $R_m$ [MPa] | $Z_{rj}$ [MPa] |
|--------------------------------|-------------|-------------|----------------|
| according to the standard St3S | min. 235    | 380 - 470   | 210            |
| Test gantry bridge crane       | 300         | 460         | 250            |

The tested tensile strength in the range of a specific standard, but the yield point, and

fatigue strength for a series of unilateral achieve a value significantly–higher than specified in the standard.

The increase in the yield point after many years of use is known in the literature as aging mechanical (called. strain aging) [2].



**Figure 4** View the turn of the static tensile test

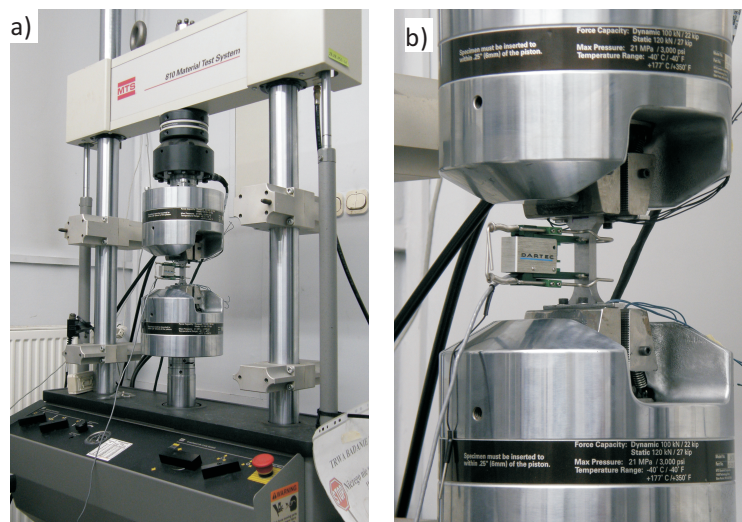

**Figure 5** Research position; a) general view, b) the method of sample loading, displacement LVDT-sensor longitudinal extensometer and the test sample

Late view of the static tensile test for a sample of inclusions shown in Fig. 4.

We also performed an endurance test sample with inclusions (W) and without inclusions (BW). The examinations were conducted according to the established research program; for a given load determined number of cycles to fatigue damage.

An endurance test was carried out on the servo hydraulic machine MTS testing 810 (Fig. 5) with a capacity of 100 kN. Machine control is carried out by via controller MTS Flex Test SE using a suitable Software (Station Manager).

In some cases, the cycle test was recorded on a periodic basis cyclic strain response of a material with a longitudinal epsilon extensometer 3542-025M-025-ST-based measurement range of 25 mm and measuring  $\pm 6.25$  mm.

Fatigue tests were carried out under the control of the load in a manner consistent with the standard PN-74 / H-04 327, samples flat geometry shown in Fig. 2, made from material taken from the bottom chord of the bridge crane. Individual samples were subjected to load a constant amplitude sinusoidal. Appropriate load frequency was chosen for a given load level in a way that is not followed by heating the sample under investigation. Realized test plan and the results are shown in Tab. 2.

**Table 2** Examples of the results of fatigue tests

| Sample | Values of stress [MPa] |           |       |       | Freq. of load-ing f [Hz] | Number of cycles effect test | Effect test               |
|--------|------------------------|-----------|-------|-------|--------------------------|------------------------------|---------------------------|
|        | $S_{min}$              | $S_{max}$ | $S_m$ | $S_a$ |                          |                              |                           |
| 1B     | -235                   | 235       | 0     | 235   | 12                       | 98 813                       | destruction of the sample |
| 2B     | 0                      | 250       | 125   | 125   | 30                       | 2600000                      |                           |
| 5B     | 0                      | 280       | 140   | 140   | 30                       | 3100000                      |                           |
| 9B     | -250                   | 250       | 0     | 250   | 3                        | 17 053                       |                           |
| 5W     | 0                      | 310       | 155   | 155   | 24                       | 2 000 000                    | no destruction            |
| 6W     | 0                      | 290       | 145   | 145   | 30                       | 2000000                      |                           |
| 10W    | 73                     | 290       | 181.5 | 108.5 | 30                       | 2000000                      |                           |
| 11W    | -235                   | 235       | 0     | 235   | 8                        | 33 795                       |                           |
| 12W    | 0                      | 280       | 140   | 140   | 30                       | 398 384                      |                           |

The measurements included two sets of samples, namely: a sample with layered inclusions lameral (Series W), and samples free of these defects (Series B).

If there was no fatigue destruction of the test specimen was stopped generally after 2 000 000 cycles. This value was adopted taking into account the maximum number of cycles, which can be subjected to a gantry over the entire lifetime.

Based on the results of fatigue tests of experimental results were analyzed.

Smith plotted for material data obtained from eresearch according to Tab. 1:

- cycle fatigue strength for both sides  $Z_{ro} = 210$  MPa
- apparent yield strength  $R_e = 320$  MPa
- tensile strength  $R_m = 480$  MPa.

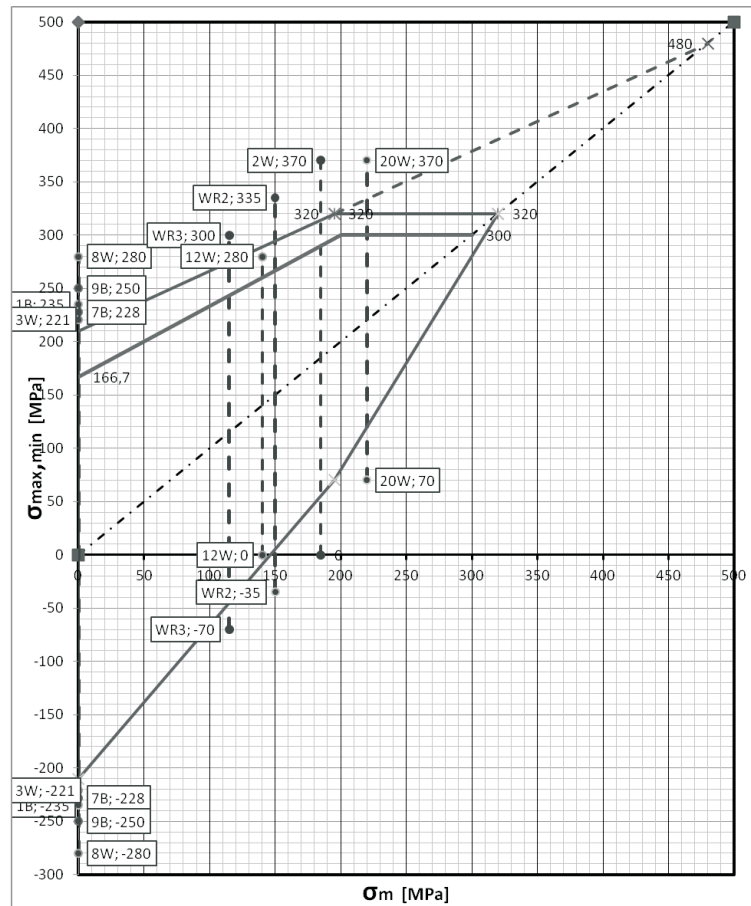

Figure 6 Smith graph with marked fatigue tests in which samples of they were destroyed

From this graph we also noted the value of yield point according to standard  $R_e = 235$  MPa.

In the chart also indicated nominal (by standards), the mechanical properties of steel St3S. The fatigue life cycle double calculated from the empirical formula [4]:

$$Z_{r,j} = 1.5 Z_{r,o}$$

$$Z_{r,o} = 167 \text{ MPa.}$$

As you can see the upper branch of the Smith chart for the values of code is much lower than a branch of material data chart for the actual steel. On so prepared Smith chart plotted lines corresponding cycles stresses samples which were carried out experimental fatigue tests.

Fig. 5 have been drawn loading cycles for which the test sample they were destroyed by fatigue.

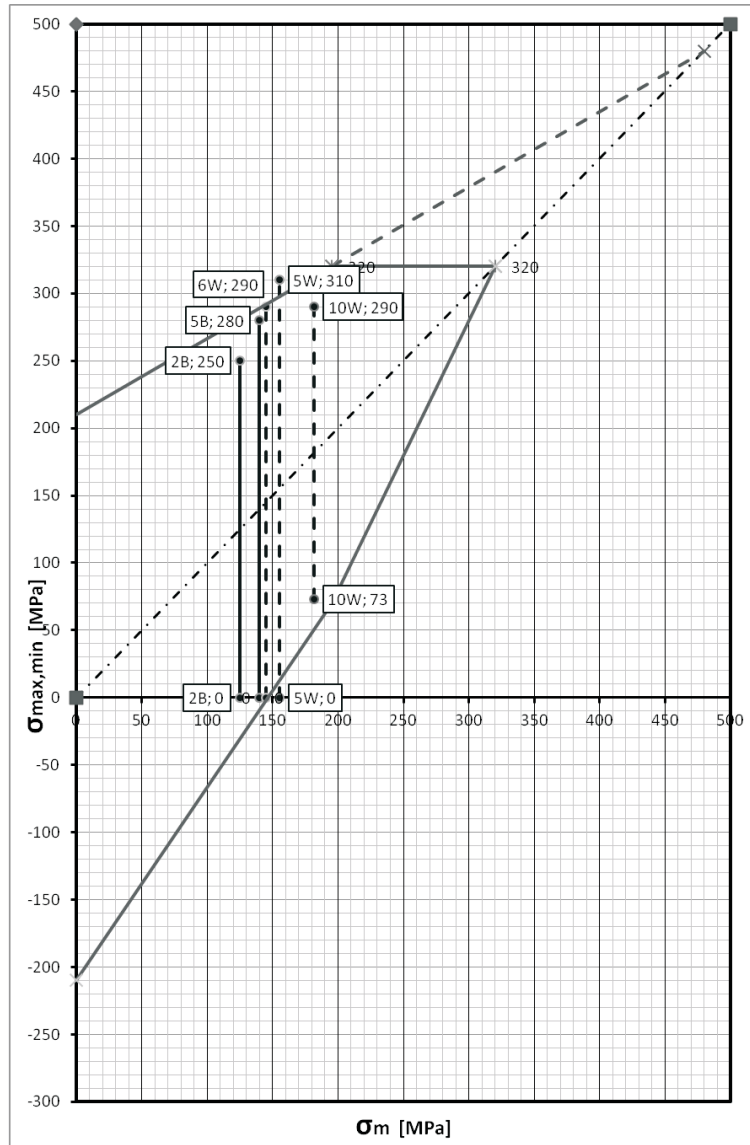

Figure 7 Smith graph with marked fatigue tests, where samples were not damaged

Symbols Framing: No. sample and the stress value (minimum or the maximum for a given cycle). Letter B (solid lines) indicated a sample without inclusions and the letter W (dotted lines) of the sample with inclusions.

As you can see, all the episodes corresponding to the test cycles fatigue tests (except one) extend beyond the area bounded by Smith chart broken.

Similarly in Fig. 6 have been drawn load cycles for which test samples were not damaged by fatigue. All cycles encumbrances (except one) are located inside the Smith chart. This means that the results of experimental studies of fatigue with the theory of fatigue materials.

### 3. Conclusions

Based on the survey you can draw the following conclusions:

- Results of fatigue tests of samples cut from the material studied experimentally crane summarized in the graph fatigue Smith. Good accordance fatigue experimental results with the theory of fatigue materials.
- Research Fatigue showed a significant effect of nonmetallic inclusions on the fatigue strength of steel.
- Fatigue strength of steel without inclusions is much higher than the fatigue strength of steel with inclusions.
- Results of fatigue tests completed the destruction of the samples are outside the Smith chart (except in one case).
- Results of fatigue terminated without destroying the sample (after reaching the number of cycles within 2000000) located inside the Smith chart (except in one case).
- The static resistance is not observed by the phenomenon of reduction in its value for the steel inclusions. However, the increasing strength properties, especially yield point steel very long time operated (approx. 50 years).

### References

- [1] Report on the implementation of the national center of Science, N 502 715140.
- [2] Structural steel designer's handbook, Third edition, *MCGraw-Hill, INC.*, pp. 36, 1999.
- [3] Blum, A. and Patch, T.: Analysis permanent deflection of bridges, overhead and cranes, *Supervision Technical*, 5, pp. 108–110, 2012.
- [4] Niezgodziński, M. E., Niezgodziński, T.: Designs graphs and tables of strength, *WNT*, Warsaw, 2012.