

Modeling of ultrasonic processes utilizing a generic software framework

This content has been downloaded from IOPscience. Please scroll down to see the full text.

2017 IOP Conf. Ser.: Mater. Sci. Eng. 211 012014

(<http://iopscience.iop.org/1757-899X/211/1/012014>)

View [the table of contents for this issue](#), or go to the [journal homepage](#) for more

Download details:

IP Address: 194.95.158.72

This content was downloaded on 28/08/2017 at 13:33

Please note that [terms and conditions apply](#).

You may also be interested in:

[A study on the influence of ultrasonic processing on microstructure during laser welding phases](#)

H D Liu, F Y Hu, A Y Cui et al.

[The Development of a Framework for Target Diagnostic Centralized Control System \(TDCCS\) in ICF Experiments](#)

Zhang Chi, Wang Jian, Yu Xiaoqi et al.

[Distributed software framework and continuous integration in hydroinformatics systems](#)

Jianzhong Zhou, Wei Zhang, Mengfei Xie et al.

[Framework for Sustainability Performance Assessment for Manufacturing Processes- A Review](#)

K Singh and I Sultan

[Two-electron stabilization in helium](#)

Tore Birkeland, Raymond Nepstad and Morten Førre

[The Advanced LIGO timing system](#)

Imre Bartos, Rolf Bork, Maxim Factourovich et al.

[Turbulence called to order](#)

Zhen-Su She and Eric Jackson

[Acceleration response research of large span floor under pedestrian load](#)

Lilin Cao, Qingwen Zhuang, Lanzhe Chu et al.

[A high-speed transmission method for large-scale marine seismic prospecting systems](#)

Song KeZhu, Cao Ping, Yang JunFeng et al.

Modeling of ultrasonic processes utilizing a generic software framework

P Bruns*, **J Twiefel** and **J Wallaschek**

Institute of Dynamics and Vibration Research, Gottfried Wilhelm Leibniz Universität
Hannover, Appelstraße 11, D-30167, Hannover, Germany

*Email: bruns@ids.uni-hannover.de

Abstract. Modeling of ultrasonic processes is typically characterized by a high degree of complexity. Different domains and size scales must be regarded, so that it is rather difficult to build up a single detailed overall model. Developing partial models is a common approach to overcome this difficulty. In this paper a generic but simple software framework is presented which allows to couple arbitrary partial models by slave modules with well-defined interfaces and a master module for coordination. Two examples are given to present the developed framework. The first one is the parameterization of a load model for ultrasonically-induced cavitation. The piezoelectric oscillator, its mounting, and the process load are described individually by partial models. These partial models then are coupled using the framework. The load model is composed of spring-damper-elements which are parameterized by experimental results. In the second example, the ideal mounting position for an oscillator utilized in ultrasonic assisted machining of stone is determined. Partial models for the ultrasonic oscillator, its mounting, the simplified contact process, and the workpiece's material characteristics are presented. For both applications input and output variables are defined to meet the requirements of the framework's interface.

1. Introduction

Ultrasonically assisted processes are in the focus of researchers since decades and numerous applications are already state of the art in industry. For investigation and research activities as well as for designing, accurate models are needed. The utilized oscillators and tools as well as the respective processes and loads span a wide range and can be very different from each other. Thus customized models for the various applications usually are developed. A wide variety of occurring loads, utilized oscillators, and modeling approaches have been studied in the past. Doumanidis et al. [1] e.g. present both an analytical and numerical model for ultrasonic welding of thin metal foils to analyze the process mechanics. Liu et al. [2] present a finite element model to allow investigations on ultrasonic surface rolling. Ultrasonically assisted drilling processes are modeled by Potthast et al. [3] as well as Heisel et al. [4]. The investigations usually concentrate on the influence of a superimposed ultrasonic vibration on process forces. For all given modeling approaches the main distinguishable feature, however, is their complexity. Both different physical domains and different size scales need to be considered to sufficiently represent the respective processes and systems. Usually either simplified models or a division into partial models are used to overcome this. The former can result in insufficient accuracy whereas the latter leads to customized and mostly complex coupling of the partial models. Usually approaches like co-simulations [5] are utilized for modeling such complex



systems. However, these approaches are mostly application-oriented and tailored for specific problems. Thus a generic but simple software framework is presented permitting an easy to implement, expandable, and well comprehensible modeling. It is capable of including different physical domains and size scales and thus permits modeling of complex processes without any significant restrictions.

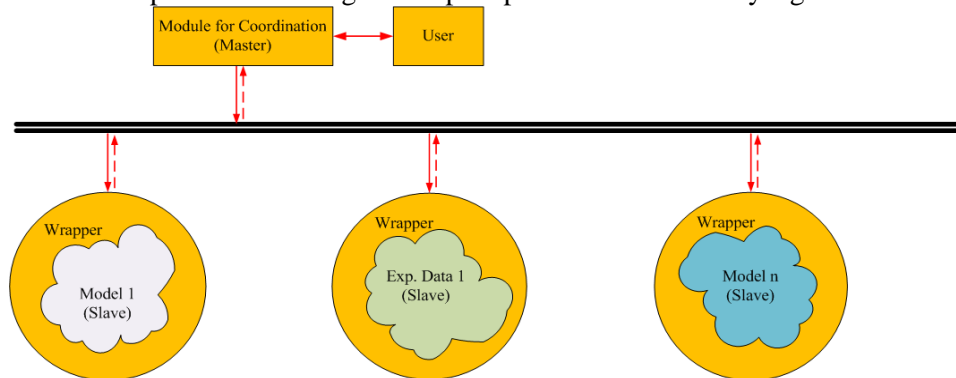

Figure 1. Principle structure of the software framework.

2. Generic software framework

The developed software framework's basic concept is depicted in Figure 1. It consists of a master module and any number of generic slave modules (wrappers) permitting implementation of the respective partial models. The parts are structured as simply as possible and implemented in the commercial software MathWorks MATLAB. The master module is essentially responsible for coordination of the calculations and simulations and thus for the execution of the slave modules in correct order. The explicit order needs to be set by the user. Slave modules can be performed once per calculation step or within an inner iteration loop (cf. Figure 2). An adaptable convergence examination is implemented permitting the selection of any parameter from the implemented partial models to be checked for convergence with a defined accuracy. Furthermore, the amount of calculation steps to be performed is determined in the master module. Hence the default abort criterion for the calculations is a manual defined number of runs through the overall model and not a model internal value. This can be adapted in the developed framework though. The definition of global variables that are not altered during the calculations and simulations in terms of a structure array is a further function of the master module. With the number of considered partial models not being limited a large amount of data possibly can be produced. Hence an appropriate data and storage management is implemented.

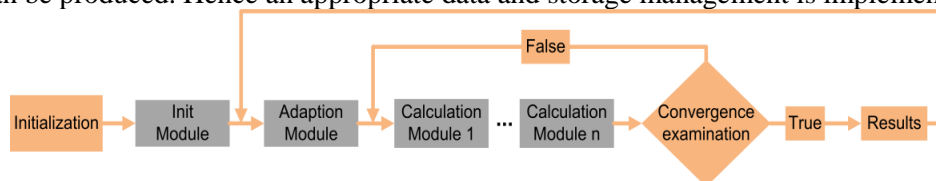

Figure 2. Exemplary flow chart of the developed master module.

The wrappers' generic character allows not only an implementation of any desired model but also of experimental, interpolated, or precalculated data. This generic character is achieved by the wrappers' well defined interfaces in terms of formatting rules for input and output parameters whereat a very simple structure is achieved (see Figure 3). Only defined parameters and variables (as well as the global structure array) are handed over from the master module to the individual wrappers and vice versa. A distinction between the respective wrappers' first and following executions is made permitting the one-off declaration of input and output variables in the respective wrapper. Specific parameters not being altered can be defined either in the respective wrapper itself or in the master module and the defined global structure array respectively. The latter permits centrally collected data of model settings and calculation results.

```

function task = wrapper_i(task_GlobalVariable)

%% Declaration and transfer of variables
switch strcmp(task.status, 'init')
case 1 %Declaration of input and output variables in first call
    task.variable = [];
    variable = value;
otherwise %Transfer of variables in any other call
    variable = task.variable(end);
end

%Declaration of model-specific variables in every call
parameter1 = value;
parameter2 = GlobalVariable.parameter2;

%% Integration of model

%% Postprocessing/Output
%Generation of output
task.variable(end+1) = variable;

```

Figure 3. Basic structure of generic slave modules.

3. Examples of application

The described framework is utilized for modeling two different ultrasonic processes. First parameterization of a simplified load model for ultrasonically-induced cavitation is presented. The model is intended to be used for investigations on the impact of cavitation and respective operating parameters on the ultrasonic oscillator. Second the hybrid process of ultrasonic assisted machining of stone is modeled with the objective to determine a process-optimized mounting position. Keeping the focus on the software framework the respective process of material removal is simplified.

3.1. Ultrasonic-Induced Cavitation

Beside ultrasonic-induced cavitation there are only few processes with so many different physical domains intermixing with each other. It includes inter alia a piezoelectric part with electrical and mechanical domain as well as the cavitation part with acoustics, fluid dynamics, and thermodynamics. Due to this complexity just a brief description of cavitation and few application examples are given in this context. Further information can be found in well-known literature, for example, [6], [7], [8] and [9].

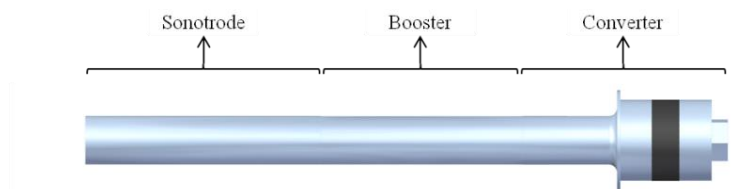

Figure 4. Ultrasonic oscillator for cavitation induction.

Figure 4 shows a model of a piezoelectrically driven ultrasonic oscillator for inducing cavitation. It consists of a converter, a booster, and a sonotrode. Applying a voltage and a current with a specific frequency in the ultrasonic range to the piezoelectric stack, results in the excitation of a longitudinal vibration mode. The converter here is an interface between the electrical and mechanical domain. Utilizing the inverse piezoelectric effect, it converts the electrical to mechanical oscillation and transfers it to the booster which modifies the amplitude [6], [10]. The sonotrode is the only part of the oscillator in contact with a liquid medium and, therefore, causes the cavitation due to its ultrasonic vibration.

The cavitation itself can be basically defined as the breakdown of a liquid medium under very low pressures [11]. It can occur in both hydrostatic and hydrodynamic liquids. In the contribution at hand a process with ultrasound being applied to a liquid stored in container is investigated. Thus only hydrostatic cavitation and acoustic cavitation respectively is considered. In accordance with [11] the effect of cavitation is comparable to boiling with the main difference lying in the driving mechanism.

For cavitation it is a drop of pressure while for the boiling it is an increase in temperature. However, due to the applied ultrasonic vibration along with the changing pressure field, pulsing bubbles are generated in the liquid and implode inter alia in dependence of their size and the pressure field. Cavitation is utilized in a variety of applications as e.g. surface cleaning [12], sonochemical processes [6] and [13], food processing [14], and ultrasonic peening [15].

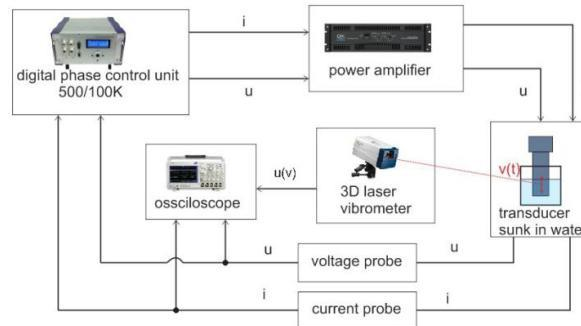

Figure 5. Experimental setup for observation of ultrasonic-induced cavitation.

The explicit models for the cavitation process can be arbitrarily complex. To allow examination of the process' impact on the oscillating system, however, there is no need to model the cavitation process itself in all details. Thus a simplified load model with sufficient accuracy is developed. Therefore, the straightforward process of cavitation is considered and the ultrasonic oscillator depicted in Figure 3 introduced into a container filled with water. The system first is examined experimentally with the setup depicted in Figure 5. Voltage and current probes are utilized to measure the electrical values. The oscillator's vibration amplitude at the front face is measured with a 3D single point laservibrometer. A database of the measured parameters is received by varying the operational parameters as driving voltage, immersion depth, and water level.

In a second step the overall model of the process and ultrasonic oscillator with a simplified load model is developed and parameterized. Therefore, the system is divided in partial models of the ultrasonic oscillator, the respective mounting, the process load, and the vibration behavior. Each partial model is implemented into a wrapper as depicted in Figure 6. In addition, the partial model types are given. The different partial model's input and output parameters are summarized in Table 1. Parameters not defined in the respective wrapper but in the master module's global structure array are not listed here.

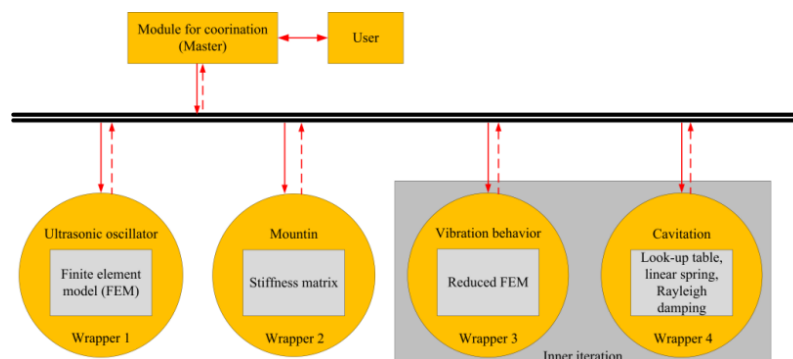

Figure 6. Partial models and respective model type for ultrasonic-induced cavitation.

Operational parameters are implemented into the global structure array in the master module. Furthermore, the execution sequence for the partial models and wrappers respectively is determined

here and corresponds to the sequence in Table 1 and Figure 6 (from left to right). Both the wrapper for calculating the vibration behavior and the wrapper with the simplified cavitation model are implemented into the framework's inner iteration loop. First free oscillation characteristics and resulting load characteristics are determined. The calculated load then is used to update the calculation of the vibration behavior and so forth. Constant vibration amplitude at the ultrasonic oscillator's front surface is defined as convergence criterion. The developed partial models are briefly summarized in the following.

Table 1. Input, and output parameters of partial models for ultrasonic-induced cavitation.

	Ultrasonic Oscillator	Mounting	Vibration behavior	Load model
Input	Index of DOF , mass, damping, stiffness matrix	Index of DOF	System of differential equations, mounting stiffness, contact forces	Index of DOF, Vibration amplitudes
Output	System of differential equations	Mounting stiffness	Vibration amplitudes, eigenfrequencies	Process forces, Rayleigh damping matrix

The ultrasonic oscillator is modeled by means of the finite element method (FEM [16]) considering both the mechanical and electrical degrees of freedom (DOF) with the commercial software ANSYS. The mass \mathbf{M} , damping \mathbf{D} and stiffness matrices \mathbf{K} are exported and within a first wrapper imported into a system of differential equations. Furthermore the system of differential equations is sorted by mechanical (master) and electrical (slave) DOF in the first wrapper (see equation 1).

$$\begin{bmatrix} \mathbf{M}_{mm} & \mathbf{M}_{ms} \\ \mathbf{M}_{sm} & \mathbf{M}_{ss} \end{bmatrix} \begin{bmatrix} \ddot{\mathbf{x}}_m \\ \ddot{\mathbf{x}}_s \end{bmatrix} + \begin{bmatrix} \mathbf{D}_{mm} & \mathbf{D}_{ms} \\ \mathbf{D}_{sm} & \mathbf{D}_{ss} \end{bmatrix} \begin{bmatrix} \dot{\mathbf{x}}_m \\ \dot{\mathbf{x}}_s \end{bmatrix} + \begin{bmatrix} \mathbf{K}_{mm} & \mathbf{K}_{ms} \\ \mathbf{K}_{sm} & \mathbf{K}_{ss} \end{bmatrix} \begin{bmatrix} \mathbf{x}_m \\ \mathbf{x}_s \end{bmatrix} = \begin{bmatrix} \underline{f}_m \\ \underline{f}_s \end{bmatrix} \quad (1)$$

An idealized mounting setup is defined in a second wrapper. The explicit nodes of the ultrasonic oscillator's FE mesh are determined and a matrix with entries in terms of a defined stiffness at corresponding positions is created as output data. It can be added to the oscillator's stiffness matrix.

Within a third wrapper the vibration behavior (vibration amplitudes and eigenfrequencies) of the ultrasonic oscillator in dependence of the load is determined. Because of the considered electrical DOF leading to zero entries in the mass matrix a static reduction in accordance with [17] and [18] has to be implemented. Furthermore, a modal reduction in accordance with [19], [18] and [20] is utilized to overcome the issue of a big amount of DOF and a high computing time respectively. Output data of this wrapper are the system's eigenfrequencies and deflection amplitudes.

The simplified cavitation model itself consists of spring-damper-elements and is implemented into a fourth wrapper. Damping and stiffness coefficients (k_{cav} , α , and β) according to the selected operational parameters are picked from an implemented look-up table. For calculation of the resulting forces a linear relation for the spring force

$$\underline{f}_m = k_{cav} \underline{x}_m \quad (2)$$

and for the damping impacts occurrence of Rayleigh damping [21] only

$$\underline{C}_R = \alpha \mathbf{M}_{mm} + \beta \mathbf{K}_{mm} \quad (3)$$

are assumed. The spring-damper-elements are connected to the nodes of the oscillator's FE mesh (cf. Figure 7). Applied forces are assumed to be the same at each node regardless of their position in x- and y-directions. Thus vectors and matrices with entries at the corresponding positions are created as the wrapper's output data.

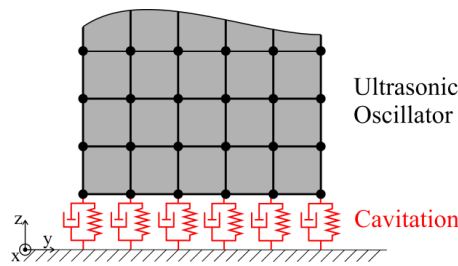

Figure 7. Schematic representation of load model for ultrasonic-induced cavitation.

The developed overall model permits a parameterization of the load model based on the conducted measurements. Therefore, the complete framework is implemented into an iteration loop. Damping and stiffness coefficients for respective operational parameters are determined iteratively and used for adapting the look-up table for the load model. The corresponding measured eigenfrequency and deflection amplitude are defined as convergence criteria.

Table 2. Comparison of experimental and numerical determined cavitation impacts on the oscillator.

Operating parameters			Experimental results		Numerical Results	
Current [A]	Immersion depth [mm]	Water level [mm]	Frequency [Hz]	Amplitude [μm]	Frequency [Hz]	Amplitude [μm]
0.7	10	27	20416	4.36	20414	4.35
1.1	10	27	20513	7.23	20515	7.21
0.7	30	47	20423	7.42	20425	7.43
0.7	30	76	20475	1.94	20747	1.92

Numerical and experimental results for a representative selection of operational parameters are given in Table 2. It becomes apparent that the developed overall model allows very good prediction of the cavitation influences on the ultrasonic oscillator. Average error regarding the eigenfrequency is 0.3 % and regarding the vibration amplitude 0.2 %. The developed overall model thus allows investigations on load influences on the oscillator's vibration shape.

3.2. Ultrasonic Assisted Machining of Stone

The second process modeled with the developed framework is ultrasonic assisted machining of stone. An ultrasonic vibration superimposed to an actual machining process reduces the occurring process forces [22], [23], improves the surface quality [24], and has a positive effect on the chip breaking [25]. However, implementing the ultrasonic system into the process increases the modeling complexity significantly. In addition to the actual feeding movement within the centimeter range and velocities around 100 m/min the ultrasonic vibration of several micrometers and at a frequency above 20 kHz has to be considered. Furthermore, the ultrasonic oscillator typically is driven by a piezoelectric converter thus the electrical domain has to be implemented into the overall model. Due to these challenges no model of the process in combination with the ultrasonic oscillator and the interactions between these two parts has yet been developed. Such an overall model though would offer distinct benefits like an improved process understanding or process optimized design of the utilized tools and mountings inter alia. The latter is selected as application example in the contribution at hand. Therefore, a simplified contact model is utilized to remain the focus on the software framework whereat the material removal itself will be neglected.

Table 3. Partial model type, input, and output parameters for ultrasonic assisted machining of stone.

	Ultrasonic Oscillator	Mounting	Workpiece characteristics	Vibration behavior	Contact process
Input	Index of DOF , mass, damping, stiffness matrix	Index of DOF	-	System of differential equations, mounting stiffness, contact forces	Index of DOF, Vibration amplitudes, young's modulus
Output	System of differential equations	Mounting stiffness	Young's modulus	Vibration amplitudes, eigenfrequencies	Contact forces

The system is divided into partial models for a given ultrasonic oscillator, the mounting, the workpiece characteristics, the simplified contact process, and for calculating the vibrational behavior. The input and output parameters are summarized in Table 3. Again parameters not defined in the respective wrapper are not listed here. These operational parameters are defined within the master module where the execution sequence for the partial models and wrappers respectively again is determined (cf. Table 3 from left to right). The partial model for calculating the vibration behavior and the partial model of the contact forces are implemented into the inner iteration loop and repeated iteratively whereat constant vibration amplitude at the ultrasonic oscillator's front surface is defined as convergence criterion.

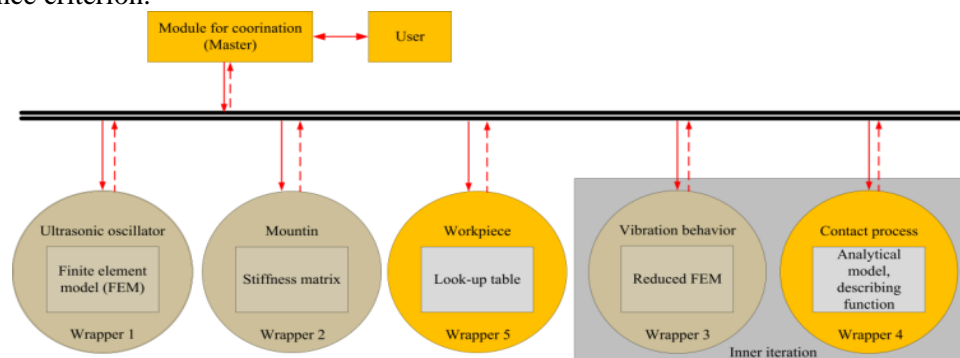
**Figure 8.** Connection between partial models for ultrasonic assisted machining of stone.

One main benefit of the software framework can be exploited for developing partial models for the oscillator, the mounting implementation, and for calculating the vibration behavior. Since respective partial models already have been developed for ultrasonic-induced cavitation those wrappers can be adapted, if necessary, and easily implemented into the new overall model. Thus the previous model's first wrapper for defining a system of differential equation similar to equation 1, the second wrapper for implementing idealized mounting conditions into a respective stiffness matrix, and the third wrapper for calculating the vibration behavior are slightly modified. Again static reduction in accordance with [17] and modal reduction in accordance with [19] are implemented. However, partial models of the contact process and workpiece characteristics need to be developed (cf. Figure 8).

The complex contact process is simplified and therefore divided into axial forces resulting from the micro hammering effect (cf. [22] and [26]) and forces in the machining plane resulting from frictional processes. Both non-linear contact forces can be described in terms of piecewise-linear stiffness as depicted in Figure 9. A linearization is inter alia possible with the describing function and harmonic balance method [27] permitting an implementation in appropriate analytical models. Considering the friction contact the resulting forces (see also Figure 9 c)) can be written as:

$$F_a = \begin{cases} -N_0 & \text{for } \hat{v}_e < -c, \\ \frac{N_0 - N}{c} \hat{v}_e - N & \text{for } -c < \hat{v}_e < 0, \\ 0 & \text{for } \hat{v}_e = 0, \\ \frac{N_0 - N}{c} \hat{v}_e + N & \text{for } 0 < \hat{v}_e < c, \\ N_0 & \text{for } c < \hat{v}_e \end{cases} \quad (4)$$

and linearized to

$$B(\hat{v}_e, N_0) = \frac{2(N_0 - N)}{\pi c} \arcsin\left(\frac{c}{\hat{v}_e}\right) + \frac{1}{\pi \hat{v}_e} \left[2c(N_0 - N) \sqrt{1 - \left(\frac{c}{\hat{v}_e}\right)^2} + 4N \right] \quad (5)$$

The determined describing function (equation 5) is equivalent to a replacement stiffness that depends on the velocity amplitude and can be easily implemented into the constitutive contact model and spring elements respectively. The described calculation of the friction forces as well as the analogous calculation of the impact forces (cf. [20]) is implemented into an appropriate wrapper. Analogous to the partial model of the mounting the explicit nodes of the ultrasonic oscillator's FE mesh at the front face are determined and a matrix with entries at corresponding positions is created. Outputs of the wrapper thus are a stiffness matrix depending on the calculated vibration amplitudes and a damping force vector. The workpiece characteristics in terms of Young's modulus are gained from literature whereat a database for different materials and probe dimensions is implemented into a further wrapper.

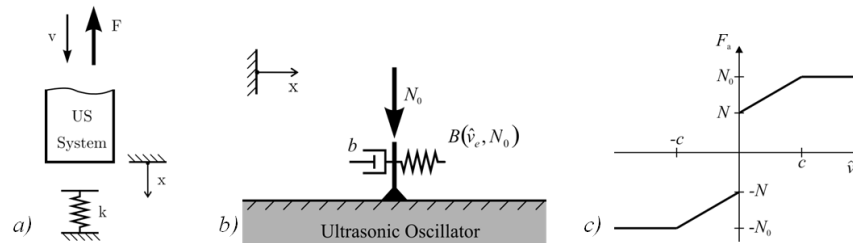

Figure 9(a). Analogous models for the impact process; **Figure 9(b).** analogous model for the friction process, and **Figure 9(c).** related force-deflection graph.

Permitting a comparison of the resulting vibration shapes and achievable deflection amplitudes the framework with the described overall model is executed for different mounting position. Starting directly next to the piezoelectric stack the mounting here is coupled to distinct positions on the converter and moved towards the sonotrode. The possible mounting positions and the minimum step size depend directly on the FE mesh and node distribution respectively. Figure 10 a) shows the calculated mean displacement amplitudes at the oscillator's front face for different mounting distances to the piezoelectric stack. A clear maximum is distinguishable thus a process-optimized mounting position located as close as possible to the piezoelectric stack can be identified. Vibration shapes of the oscillator with original and optimized mounting positions can be easily calculated with the developed overall model and are depicted in Figure 10 b). Again the increase in displacement amplitudes is apparent. In addition, a load impact in terms of a shift of the maximum displacement away from the front face can be noticed. In the region of the piezoelectric stack load and mounting impacts are negligibly small.

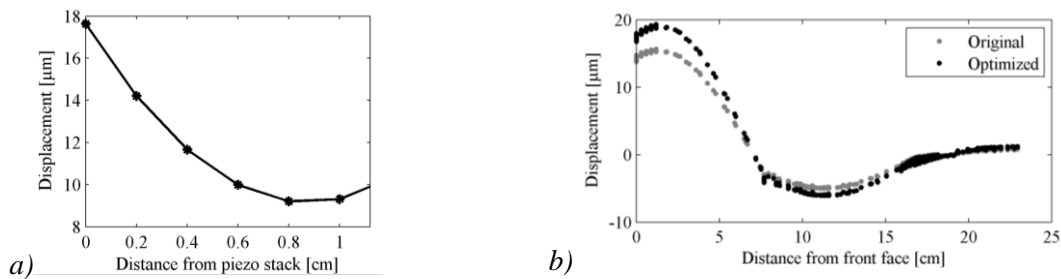

Figure 10(a). Mean displacement amplitudes at oscillator's front face for different mounting positions.

Figure 10(b). vibration shapes of original and optimized oscillator.

4. Conclusion

In the contribution at hand a generic but simple software framework implemented in MathWorks MATLAB is presented. By dividing the respective overall model into partial models it is applicable for processes and systems of almost any complexity. The framework consists of a master module for coordination and any number of slave modules with well-defined interfaces permitting the integration of the partial models. The defined format of the respective input and output parameters leads to the frameworks generic character and an easy coupling of the wrappers. Furthermore, there are no significant restrictions in terms of partial model type to be included (e.g. experimental data, interpolated data, analytical models, or numerical models). The framework is demonstrated by means of two explicit application examples and tasks respectively that could be satisfactorily solved. Considering the cavitation process and the presented simplified load model an experimental based parameterization could be performed. The developed overall model is capable of predicting the cavitation influences on an ultrasonic oscillator without consideration of complex descriptions of the cavitation process itself. In addition, a sufficiently high accuracy can be reached. A process-optimized mounting position could be identified by modeling the process of ultrasonic assisted machining of stone in terms of process loads, ultrasonic oscillator, and respective interactions. Integrating the overall model into the developed framework, furthermore, permitted the determination of load impacts on the utilized oscillator's vibration shape.

In conclusion, the easy integration of partial models into the developed framework and the possibility of adapting existing partial models for new modeling tasks became apparent in particular. Further benefits of the developed framework are the arbitrary expandability and the good comprehensibility of the overall models due to the clearly defined but still simple coupling of clearly separated partial models.

References

- [1] Doumanidis C and Gao Y 2004 Mechanical modeling of ultrasonic welding *Welding Journal-New York* **83** 4 pp 140-S
- [2] Liu Y, Lijun W and Dongpo W 2011 Finite element modeling of ultrasonic surface rolling process *Journal of Materials Processing Technology* **211** 12 pp 2106-13
- [3] Potthast C, Twiefel J and Wallaschek J 2007 Modeling approaches for an ultrasonic percussion drill *Journal of Sound and Vibration* **308** 3 pp 405-17
- [4] Heisel U et al 2011 Kinematic Model for Ultrasonic-Assisted Manufacturing of Bore Holes with Undefined Cutting Edges *Advanced Materials Research (Trans Tech Publ)* **223**
- [5] Tudoret S, et al 2000 Co-simulation of hybrid systems: Signal-Simulink *Int. Symp. on Formal Techniques in Real-Time and Fault-Tolerant Systems* (Springer Berlin Heidelberg)
- [6] Crawford A E 1955 *Ultrasonic Engineering* (Butterworths, London)
- [7] Flynn H G 1964 Physics of acoustic cavitation in liquids *In Physical acoustics* ed W P Mason (New York: Academic) IB p 157

- [8] Franc J P and Michel J M 2004 *Fundamentals of Cavitation* (London: Kluwer Academic Publishers, Dordrecht, Boston)
- [9] Brennen C E 2014 *Cavitation and Bubble Dynamics* (Cambridge: Cambridge University Press)
- [10] Ikeda T 1990 *Piezoelectricity* (New York: Oxford university press)
- [11] Franc J P and Michel J M 2004 *Fundamentals of Cavitation* (London: Kluwer Academic Publishers, Dordrecht, Boston)
- [12] Shchukin D G, et al 2011 Ultrasonic cavitation at solid surfaces *Advanced Materials* **23** 17 pp 1922-1934.
- [13] Suslick K S 1989 The chemical effects of ultrasound *Scientific American* **260** 2 pp 80-6
- [14] Knorr D, Zenker M, Heinz V and Lee DU 2004 Applications and potential of ultrasonics in food processing *Trends in Food Science & Technology* **15(5)** pp 261-6
- [15] Mordyuk B N and Prokopenko G I 2007 Ultrasonic impact peening for the surface properties' management *Journal of Sound and Vibration* **308** Jg Nr 3 S pp 855-66
- [16] Knothe K and Wessels H 2008 *Finite Elemente* (Springer Verlag Berlin Heidelberg)
- [17] Guyan R J 1965 Reduction of stiffness and mass matrices *The American Institute of Aeronautics and Astronautics Journal* **3** 2 p 380
- [18] Bruns P and Twiefel J 2015 Influences of Non-axial Process Loads on the Transducer and the Associated Mounting *Ultrasonic Machining. Energy Harvesting and Systems* ISSN (Online) pp 2329-8766 ISSN (Print) pp 2329-8774
- [19] Weaver V, Timoshenko S P and Young D H 1990 *Vibration problems in engineering* 5th ed (Fong and Sens Printers Ltd)
- [20] Bruns P, Twiefel J and Wallaschek J 2016 Experimental and Theoretical Investigation of a Vibro-Impact Process Utilizing an in situ Capacitive Distance Measurement *Proceedings of ISMA2016 International Conference on Noise and Vibration Engineering, L wen*
- [21] Craig R R and Kurdila A J 2006 *Fundamentals of structural dynamics* (John Wiley & Sons)
- [22] Heisel U, Eisseler R, Eber R, Wallaschek J, Twiefel J and Huang M 2011 Ultrasonic-assisted machining of stone *Prod. Eng. Res. Devel.* **5** pp 587-94
- [23] Stehle T, Eisseler R, Drewle K, Weiland S, Bruns P and Twiefel J 2015 Investigation of Process Forces of Ultrasonically Assisted Scratch Tests *Proc. of the 3rd International Conference on Stone and Concrete Machining (ICSCM)* Bochum (Germany), pp 137-45
- [24] Silberschmidt V V, Mahdi S M A, Gouda M A , Naseer A, Maurotto A and Roy A 2014 Surface-roughness improvement in ultrasonically assisted turning *Procedia CIRP* **13** pp 49-54
- [25] Babitsky, et al 2003 Ultrasonically assisted turning of aviation materials *Journal of Materials Processing Technology* (**132**) pp 157-67
- [26] Twiefel J, et al 2008 Fundamental experiments as benchmark problems for modeling ultrasonic micro-impact processes *Journal of Electroceramics* **20** 3-4 pp 209-214
- [27] Zhang W S 1992 Nonlinear Vibrations of Piecewise-Linear Systems by Incremental Harmonic Balance Method *Journal of Applied Mechanics* **59** 1-2 p 153

Acknowledgment

The work was supported by the German Research Foundation (DFG).