

# Smart Safeguard

Stephen Marrone

Advisor: Bridget Benson

EE 460 Project Report  
Cal Poly San Luis Obispo  
Electrical Engineering Department  
Fall 2016

# Contents

- Abstract..... 1
- General Introduction..... 2
- Overview ..... 4
  - Product Description ..... 4
  - Market Research..... 4
- Customer Archetype and Market ..... 5
  - Customer Archetype ..... 5
- Market Size ..... 5
  - Smart Safeguard Market Penetration..... 5
- Market Description ..... 6
  - Detailed Description ..... 6
  - Limitations of Present Solution..... 6
  - Strengths..... 6
  - Underserved Portion of the Market ..... 6
  - Window of Opportunity..... 7
  - Market Penetration Effort ..... 7
  - Key Partners ..... 8
  - Key Customers ..... 8
- Business Model Canvas..... 10
- Marketing Requirements ..... 11
- Marketing Data Sheet ..... 12
- Customer Requirements ..... 13
- Specifications ..... 15
  - Block Diagrams..... 15
  - Engineering Requirements..... 17
  - Testing and Verification ..... 26
- Plan of Attack ..... 18
  - Timeline..... 18
  - Detailed Timeline ..... 19
  - Product Cost Estimation – Bill of Materials ..... 20
- Design..... 20
  - Hardware – Schematic ..... 20
  - Hardware - Layout ..... 21
  - Software – Accelerometer Calibration..... 23

Software – Main Loop.....	24
Software – Crash Detected Subroutine .....	25
Analysis of Senior Project Design.....	30
Summary of Functional Requirements .....	30
Primary Constraints .....	30
Economic.....	30
Commercial basis .....	30
Environmental.....	31
Manufacturability and Sustainability .....	31
Ethical.....	31
Health and Safety.....	31
Social and Political .....	31
Development.....	32
References .....	32

## Abstract

Smart Safeguard is designed to provide people with an affordable device that will notify the authorities when the buyer gets in a car crash. The device will operate off the 12V car power that is present in every car and use an accelerometer to detect if an accident has occurred. If an accident is detected the device will proceed to light up and make a noise until the passenger pushes a button on the device. If the passenger doesn't push the button within 15 seconds the device, which is wirelessly connected to the passenger's phone, will initiate a text to 911 via the cell phone. The text includes a help message and the coordinates of the smart safeguard. This allows the authorities to be notified that there is a problem within 15 seconds of an accident. If the driver is ok, and doesn't need the authorities he/she can push the button and the device will not text 911.

This device needs to be affordable so that most consumers can afford it. The device also needs to be compact and sturdy so that it can survive a car accident. The device will only need to be powered by the 12V car adapter that most cars have. The system will incorporate a microcontroller, a Bluetooth transmitter/receiver, an accelerometer, a buzzer, a button, and a LED. This device will give people an alternative to On-Star and help to save lives for people who have older cars without On-Star capability.

## General Introduction

Annually 1.3 million people worldwide die from car crashes and another 20-50 million are injured (Asirt). Per the U.S. government census, in 2009, over 33,000 people in the United States were killed in car accidents.

**Table 1:** U.S. National Summary of Fatal Vehicle Accidents (2009)

Fatal Crashes	30,797
Persons Killed in Fatal Crashes	33,808
Vehicle Occupants Killed in Fatal Crashes	24,474
Pedestrians Killed in Fatal Crashes	4,462
Motorcyclists Killed in Fatal Crashes	4,092

From the United States Statistics in **Table 1** we can see that car crashes can be extremely dangerous for not only the vehicle drivers, but also passengers and pedestrians. While most deaths were occupants of the vehicle, a large amount of motor vehicle deaths were pedestrians.

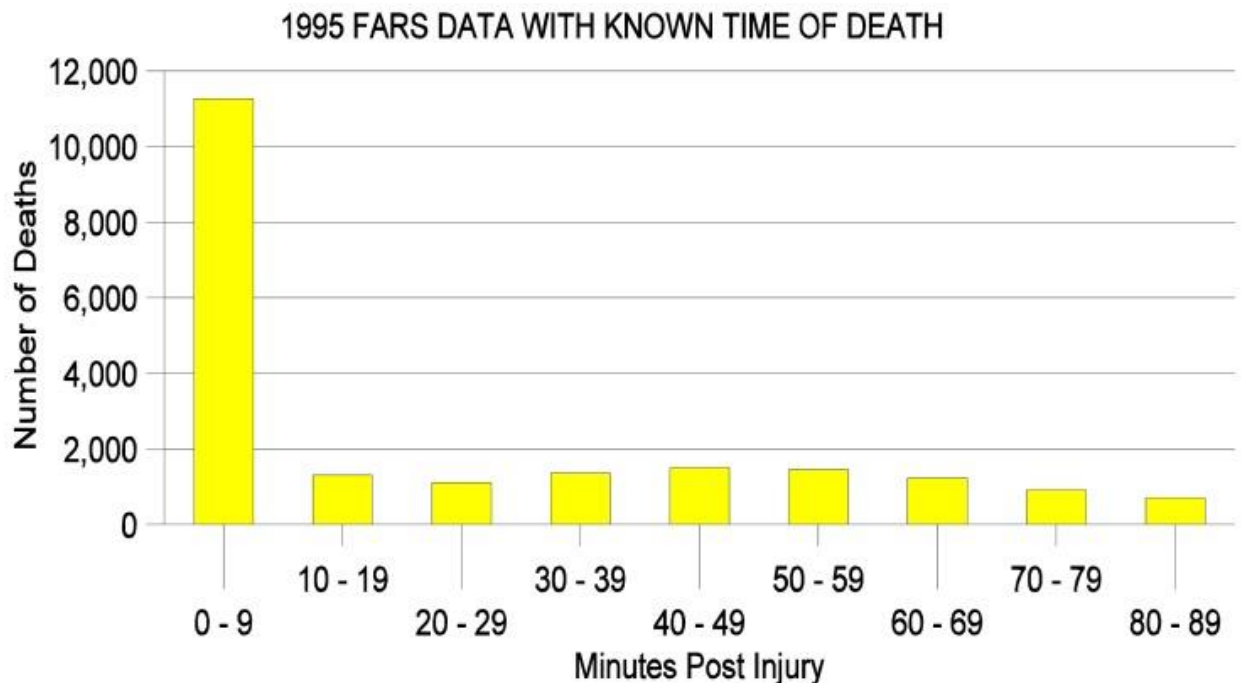

**Figure 1:** Time of Death of Automobile Accident Victims

**Figure 1** above shows that, of the known time of death accidents, most automobile accident fatalities occur 0-9 minutes' post-crash. 46 percent of the automobile fatalities occurred within the first 30 minutes (Luchter). The number of deaths in this range is huge compared to the other time ranges. If something can be done to improve the response time of emergency responders, then some of these deaths could be prevented. A major problem with this is that if an accident is serious enough to be fatal, chances are that the victims are unable to alert the emergency responders. The victims are then at the mercy of chance, hoping that a passerby will see the accident call 911 soon. It can take minutes to hours for someone to notice the accident and call 911, especially if the accident occurs in a rural area.

Teens are especially likely to be in fatal car accident. The number one cause of death for American teens are car crashes. **Figure 2** below shows that motor vehicle accidents account for more teen deaths than homicide and suicide combined. Over 33% of teen deaths are due to motor vehicle accidents.

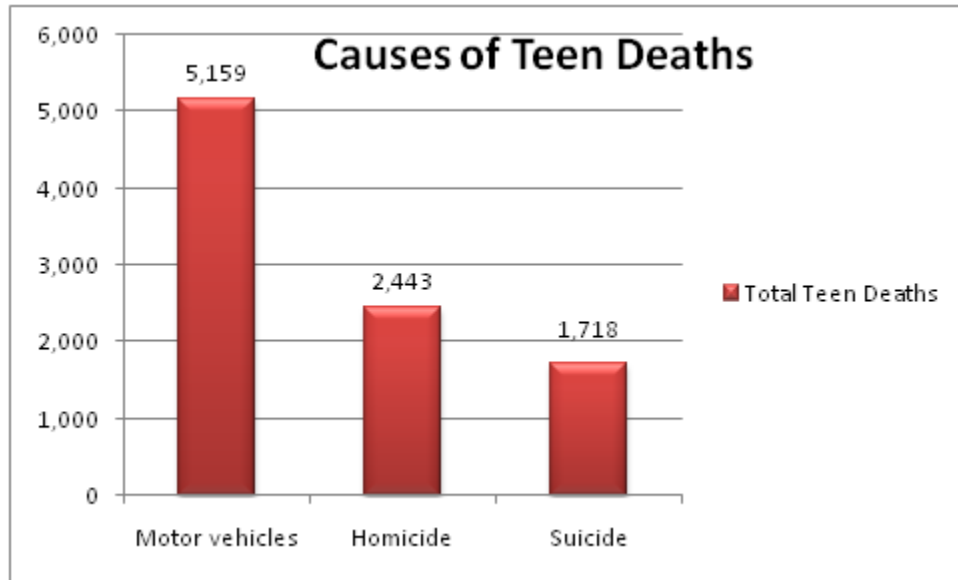

**Figure 2:** Causes of American Teen Death

Many people are also injured in motor vehicle accidents. While over 33,000 Americans were killed another 2 million Americans were injured in 2009 from motor vehicle accidents. Driving automobiles is one of the most dangerous actions that people do daily.

# Overview

## Product Description

The Smart Safeguard reduces the amount of automobile related death and serious injury by improving the safety of traveling in a motor vehicle for everybody involved. It is an affordable, compact, and sturdy device that plugs into the 12V cigarette lighter within many motor vehicles. The Smart Safeguard uses sensors to detect if your car is involved in an accident. If an accident is detected it then prompts the user to push a button if they are unharmed. If the user fails to do so it will text 911 via a Bluetooth connection to the user's phone. If the user indicates that they are ok and the accident was not serious then the Smart Safeguard does not text the authorities.

## Market Research

OnStar is the most popular solution to dangers of driving a car. OnStar must be built into the car and is subscription based. Similarly, to Smart Safeguard, OnStar uses sensors built into the car to determine if a crash has occurred. If a crash is detected an OnStar employee is connected to you and will call the authorities if needed. Smart safeguard is superior to OnStar because no subscription is needed and it is compatible with any car, unlike OnStar. Smart Safeguard will be cheaper than OnStar after a couple of months of having to pay for an OnStar subscription. For a customer to use OnStar it must be built into their car and they must pay for the subscription. For a customer to use Smart Safeguard they must have a 12V DC output in their car and a cell phone with Bluetooth capability.

Another leader in the emergency notification industry is the SOSmart App. This app uses sensors in your phone to detect car accidents and then notifies people on your emergency contact list that you were in a crash. Smart Safeguard differs from SOSmart because it is compatible with any phone that has Bluetooth capabilities while SOSmart only works with iPhones and Androids. Smart Safeguard also directly contacts 911 while SOSmart contacts your emergency contacts and they must then call 911 for you.

The smart Safeguard improves the survivability of car accidents by decreasing the reaction time of the emergency responders. It accomplishes this by automatically texting them almost immediately after the occurrence of a car crash. Because the device works on its own, is always detecting if an accident has occurred, and does not need any human interaction to operate it is consistent and works regardless of the severity of the accident. This can greatly decrease the chance of fatality, as well as the severity of injuries sustained.

# Customer Archetype and Market

## Customer Archetype

The main customer archetypes that will purchase Smart Safeguard is the safety conscience parent of a teenage boy that is beginning to learn to drive. The safety conscience parent is likely between the ages of 45-60 and is middle class. Their child is 15-16 years old and likely male. He has just started to take driving lessons. Ideally their teen child could get his license and then help around the house, by driving himself to school and taking the younger child to their sports practices or play dates. The safety conscience parents do not fully trust their teen child to drive himself yet and even when he passes his driver's test they will always be worried about him driving. Smart Safeguard is the ideal solution to their problem. It's one time, affordable price tag is not a problem for them and it is inconspicuous and out of the way during normal operation of the car. It is easy to install and it just works. The older parents can easily install it without any prior knowledge of similar devices. The Smart Safeguard is a compelling solution to the safety conscience parents worries because it allows them to give their child freedom to drive while bolstering the safety of his car. Their teen son won't complain about the device because it stays out of the way. With the smart safeguard purchased and installed in each one of the family cars they can now let their teenage son drive to school and help with groceries or their younger child with a calm mind.

The Smart Safeguard solves the pains of the worrying of the safety conscience parent. The parents know they need to let their son learn how to drive and practice driving alone, but they are worried that their son will be reckless and get into a serious accident. The Smart Safeguard calms their worries by increasing the safeness of their son's car.

The Smart Safeguard is more affordable and easier to use than the competition. Unlike SOSmart no app is required so any Bluetooth compatible smartphone will work. It is very easy to install and connect to and Unlike OnStar no preexisting hardware is required to be built into the car. OnStar requires a monthly subscription to gain access to the safety features. Smart Safeguard is a onetime buy and it will save you money after the first 3 months.

## Market Size

In his article *Not Satisfied with OnStar's Steady Profits, GM Wants to Create A Global 4G Powerhouse* Guilford says "Analysts peg OnStar's revenues at about \$1.5 billion annually, with a margin of 30 to 35 percent." OnStar is taking in over a billion dollars a year. Guilford later mentions in his article that OnStar has two services. One for safety and roadsides assistance and another for navigation and turn by turn directions. It's safe to assume that most of OnStar's money comes from the safety and security portion as many people have smart phones now with accurate and free turn by turn navigation features. Another market player is the app SOSmart. This app only has 10,000 downloads on the android app store and it is free to use. I assume that the iOS app has a similar number of downloads and is also free. With this knowledge, it is safe to say that the total market size for automatic emergency notification is \$1billion.

## Smart Safeguard Market Penetration

Smart Safeguard can capture 5% of the market initially. It will do this by appealing to safety conscience parents with and without OnStar. After the Safety Conscience parents have purchased Smart Safeguard



we will move onto a more broad customer definition in order to penetrate the market further. This will be done via word of mouth and small ad campaigns that are focused toward our target customer archetype.

## Market Description

### Detailed Description

Smart Safeguard is an intelligent, compact, and affordable first responder notification device. It is a device that you plug into your car, pair with your phone via Bluetooth, and leave alone. It can detect car crashes and text 911 if you are unable to via the Bluetooth connection to your phone. Smart Safeguard utilizes multiple accelerometers to detect car crashes. If a crash is detected it will utilize the built-in speaker and LED to prompt the user to push a button on the device. If 15 seconds go by without the button being pushed it will then send a command to the paired phone to text 911. The emergency responders can then quickly send an ambulance to the crash site with the location obtained from your phone. Smart safeguard utilizes a power efficient microprocessor to interpret the accelerometer and Bluetooth module. The device will have a custom PCB to save space.

### Limitations of Present Solution

**Table 2:** Limitation of Current Solutions vs. Smart Safeguard

<b>Solution</b>	<b>Response Time</b>	<b>Price</b>	<b>Car Compatibility</b>	<b>Phone Compatibility</b>
<b>OnStar</b>	Greater than 1 minute	\$19.95 a month	Must be built into car	N/A
<b>SOSmart</b>	Greater than 2 minutes	Free	Any Car	iOS and Android Phone sensors vary
<b>Smart Safeguard</b>	15 seconds	\$80	Any Car	Any Android phone

### Strengths

Smart Safeguard has advantages over all the current market solutions. When compared to OnStar Smart Safeguard has a faster response time because it directly notifies the emergency first responders. Smart Safeguard is also cheaper after the first 4 months of use and is compatible with any car, while OnStar is \$20 a month and the car must have the service included.

When compared to SOSmart Smart Safeguard has a faster response time because SOSmart just notifies your emergency contacts and leave it up to them to contact 911. Smart Safeguard is also compatible with many more phones including non-smart phones. SOSmart depends on the built-in sensors of phones so it might not detect crashes depending on which phone a user has. Smart Safeguard will not have that problem due to the built-in hardware.

### Underserved Portion of the Market

There are several large areas of the market that are not well served. Many older cars do not have OnStar build in and those potential customers are unable to use OnStar if they wanted to. Also, many price sensitive customers cannot afford to pay \$20 a month for OnStar so even if their cars support the service they do not use it.

### Window of Opportunity

The window of opportunity for Smart Safeguard to seize the market is within 2 years. There is only one major competitor, OnStar, and they have most the market. OnStar is only available in GM cars so they cannot expand unless they open their technology up to other car companies. It does not seem like other companies are competing with OnStar however, with car becoming more connected every day I don't doubt that companies will begin competing with OnStar. Each year more and more technology gets included in cars. Eventually an emergency first responder contact system will become standard or self-driving cars will become standard. Once self-driving cars become standard there will be significantly fewer accidents and less people will want to buy a device like Smart Safeguard. The market is ready for Smart Safeguard now. I plan to launch my product in the Spring of 2016. I hope to seize the market quickly within two years.



### Market Penetration Effort

For Smart Safeguard to enter the market we would need an inventory of working devices and a small marketing budget. Our target customer is well defined and marketing to the safety conscience parent won't be too difficult. After selling to the safety conscience parent we can expand our business to current OnStar users to capture some of their market share.

## Key Partners

To successfully manufacture and ship Smart Safeguards I will need to partner with Electrical Component suppliers, PCB manufactures, OEMs, and Shipping Companies.

**Table 3:** Key Partners

	<p>Digi-Key is an electronic component supplier. A partnership with them will allow me purchase my electronic components for a cheaper cost. They will supply the microcontroller, Bluetooth module, battery, as well as any other miscellaneous electronic components that I need.</p>
	<p>UPS is the world's largest package delivery company. They have the infrastructure to quickly and affordably ship Smart Safeguards to anyone in North America. Working with them is a must in order to give good customer service to buyers from the Smart Safeguard website.</p>

## Key Customers

To sell the most devices, we would need to partner with physical retailers such as target and best buy and online retailers such as amazon and Newegg. It would also be smart to team up with automotive specific shops such as AutoZone and websites such as rock auto.

I think that Target is a key potential retailer for Smart Safeguard. Many middle-income parents of teens shop at Target. Partnering with Target and placing our product at the correct spot within their stores will allow for Smart Safeguard to be seen by the most potential customers

**Table 4:** Advantages and Disadvantages of Smart Safeguard

Advantages	Disadvantages
Affordable	A physical purchase is necessary, it's not as convenient as OnStar.
Quick – 15s Response Time	Binary – only text 911 or not text 911.
Compatible with almost every car and phone	Takes up a 12V car slot that you can no longer use for other things

# The Business Model Canvas

Designed for: Smart Safeguard

Designed by: Stephen Marrone

Date: 10/22/2016

Version: 01

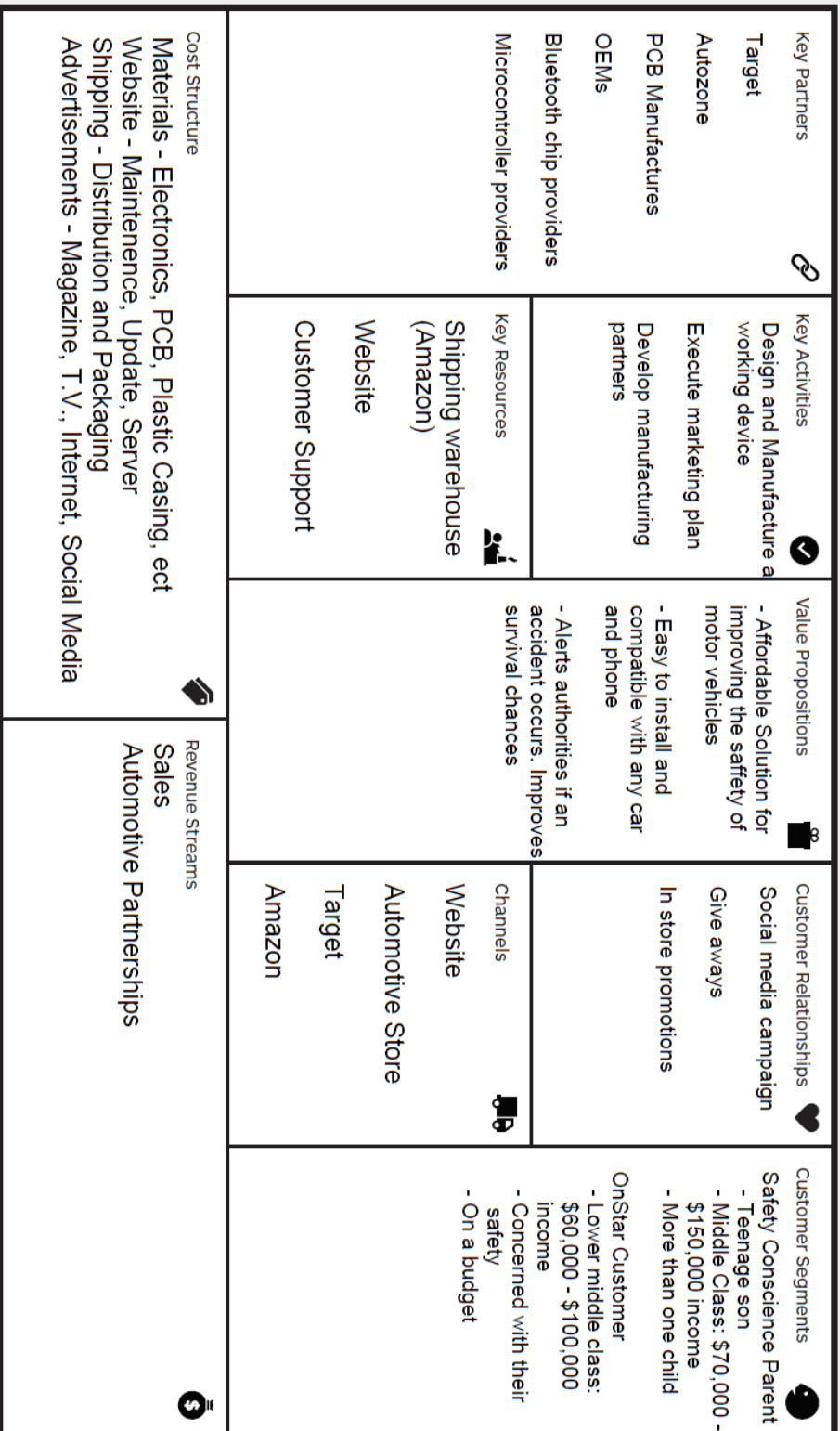

## Marketing Requirements

- Compact: No larger than 8"x6"x4" at largest point. This requires a custom PCB.
- Affordable: Smart Safeguard shouldn't cost more than \$80 per device
- Easy to Use: The device should be able to be set up in under 3 minutes. After the initial setup, the device should not require any tweaking or reconnecting to the same phone. There will need to be a memory module so that the device can remember connected phones even when the car is powered down
- Accurate: The Smart Safeguard needs to use high accuracy accelerometers to accurately and consistently detect car crashes
- Low Power: The device will use Bluetooth 4.0 or above so that the battery drain on the user's phone is not significant.
- Robust: The device will need to withstand the worst car accidents. High quality plastic will be used for the enclosure.

# Marketing Data Sheet

**Product/Project Name:** Smart Safeguard

**Unmet Customer Need:**

- Emergency contact device for older cars
- Affordable alternative to OnStar

**Unique Value Proposition:**

Smart Safeguard is an affordable way to improve the safety of any motor vehicle.

**Target Customer:**

- Safety conscience parent of new teen driver

**Positioning:** The smart safeguard is the easiest most affordable way to bolster the safety of any motor vehicle

**Customer Benefits:**

- Affordable – No Subscriptions
- Improved sense of safety
- Increased chance of survival

**Sustainable Differentiation:**

- Compatible with any car
- Can withstand even the worst car accidents
- Easy to use and install
- Works well consistently

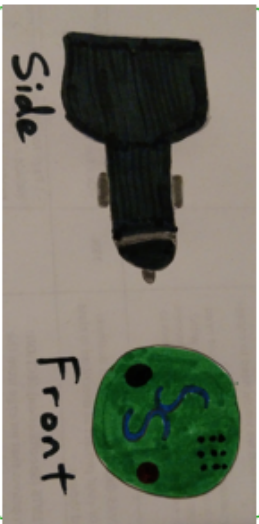

**Pricing and Availability:**

- \$40
- Senior Project Expo
- Spring 2017

**Product Objectives:**



- Gain over 50% market share in 4 years
- Provide an option for people without OnStar
- Affordable for all incomes

**Disruptive Go-to-Market:**



- Aggressive marketing plan
  - Point out advantages of Smart Safeguard over competition
- Social Media campaign
- Make it easy for customers to buy the Smart Safeguard

## Customer Requirements

**Table 5: Customer Requirements**

Customer Need	Diagram	Reason
Compact		<ul style="list-style-type: none"> <li>• Some cars 12V DC outlet are hard to reach or have little to no room for larger chargers.</li> <li>• If the Smart Safeguard is not compact it will limit the compatible cars</li> <li>• Customers want something that won't get in their way during normal use.</li> </ul>
Use only the 12V DC Outlet for Power		<ul style="list-style-type: none"> <li>• Smart safeguard needs to work with all cars so that any potential customer can use our device</li> <li>• This allows the device to be plugged in easily. No extra cables.</li> </ul>
Bluetooth		<ul style="list-style-type: none"> <li>• Bluetooth allows for customers to only need to connect their phone wirelessly one time</li> <li>• Every time after their phone will automatically pair</li> <li>• Allows for compatibility with most phones both "smart" and "dumb"</li> </ul>

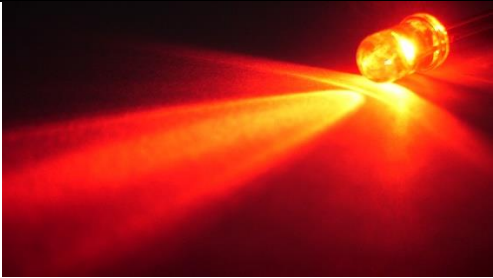

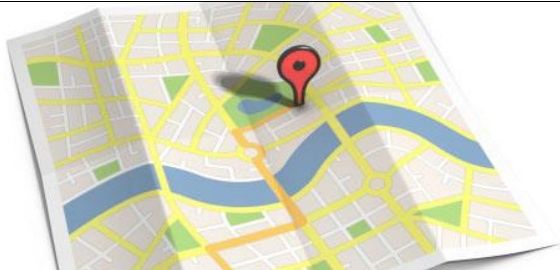
LED Lights		<ul style="list-style-type: none"><li>• The customer will need to quickly locate the device in the event of a minor accident.</li><li>• The LED helps the customer to visually locate the device.</li><li>• The LED also reminds the customer that the device will text 911 if they do not push the included button</li></ul>
Buzzer		<ul style="list-style-type: none"><li>• The buzzer alerts the customer that the Smart Safeguard detected a crash</li><li>• The buzzer helps the customer to locate the device after a car accident</li></ul>
GPS		<ul style="list-style-type: none"><li>• GPS allows the Smart Safeguard to send the users location to the authorities</li></ul>

# Specifications

## Block Diagrams



**Figure 3:** Level 0 Black Box Diagram

The Smart Safeguard must work on 12V power provided by a car cigarette lighter. It will incorporate an Accelerometer to determine if a car crash has occurred. The Smart Safeguard will constantly monitor the Accelerometer so that if a crash does occur, it can detect it immediately. An external button will be available for the user to press in the event of an accident. The Smart Safeguard has 3 different outputs. The speaker and LED are there to notify the user that 911 will be texted if the button is not pressed. The Smart Safeguard also has a Bluetooth connection to the user's phone to text 911 if needed. The LED should be bright enough to be noticed during daylight, but it cannot be so bright that it distracts a driver in the event of a false crash detection. The speaker is there to supplement the LED so that if the Smart Safeguard is out of vision the passenger can still hear the speaker. The Accelerometer must be able to detect large changes in acceleration so that a car crash be accurately differentiated from slamming on the breaks.

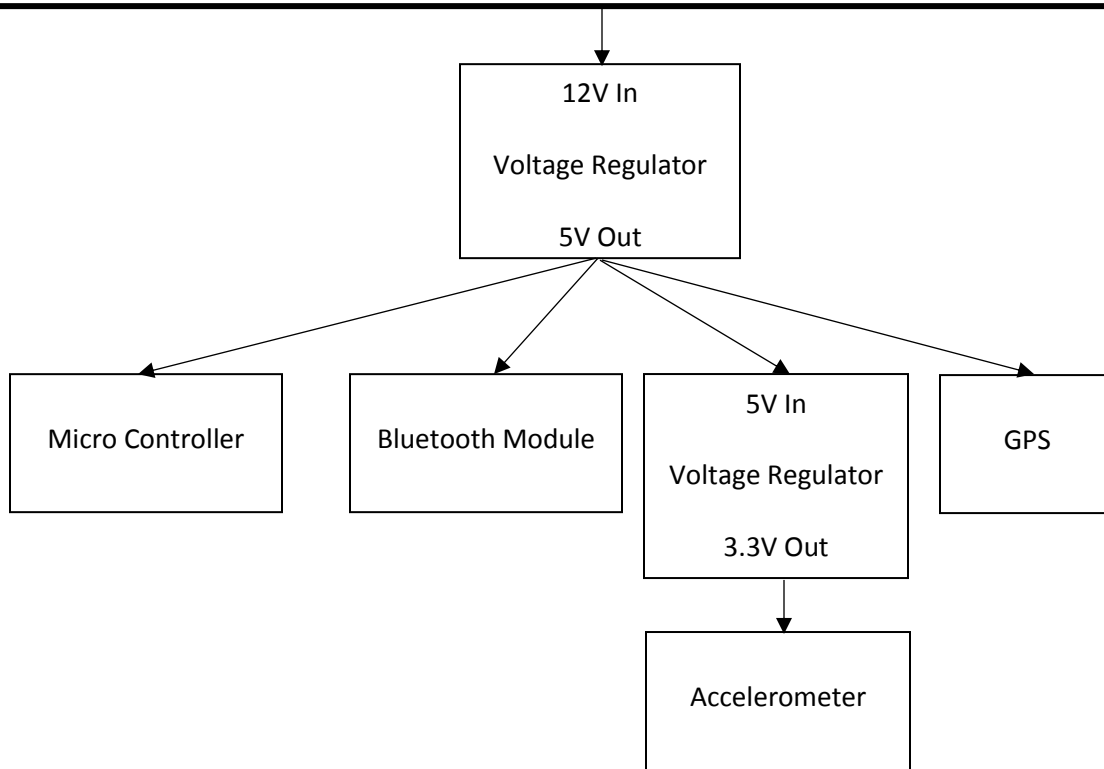

**Figure 4:** Power Subsystem Block Diagram

**Figure 4** above showcases the power system of Smart Safeguard. The 12V supply will initially need to be dropped down to 5V because the ATmega 328P, Bluetooth module, and GPS Module all run on 5V. Another Voltage regulator will be needed to drop the 5V down to 3.3V because the accelerometer has a maximum power supply voltage of 3.5V. The Maximum current draw from this system should be less than 500mA and during normal operation the current draw should be less than 100mA.

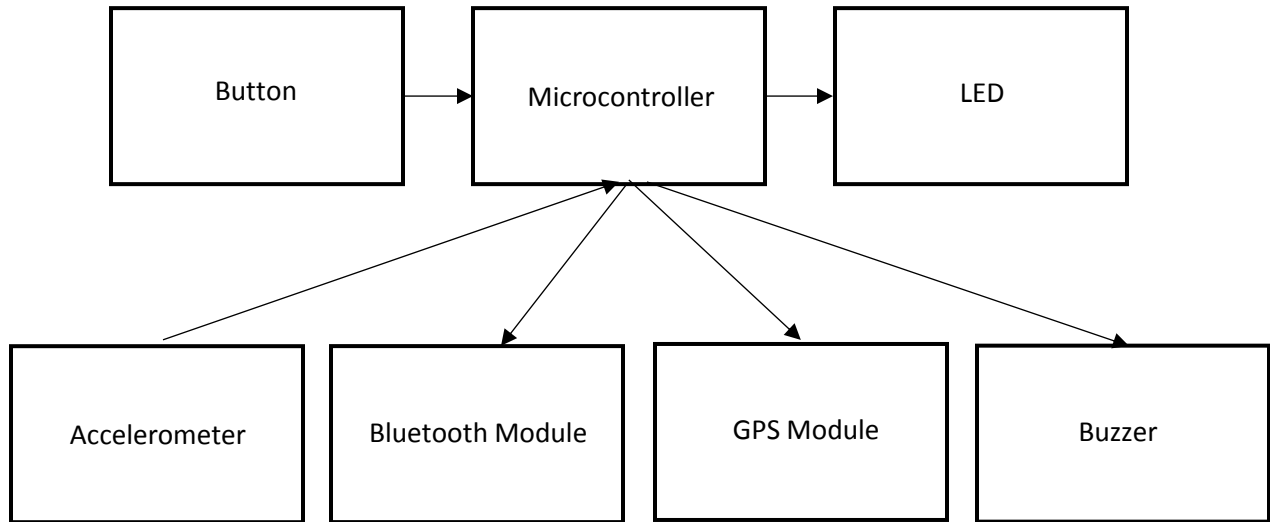

**Figure 5:** Microcontroller Subsystem

The microcontroller takes in data from the accelerometer, which needs to be rated to 20Gs, and button. Based on the received data it controls a LED, speaker driver, and Bluetooth module. While powered on the microcontroller must always monitor data from the accelerometer. It will constantly check to see if a sudden change in acceleration occurs. If a sudden change in acceleration occurs the microcontroller interprets this as a car crash. When a crash occurs, the micro controller starts an internal timer for 15 seconds. While waiting for the timer to expire it flashes the LED and plays an alarm sound from the speaker. If the button is pressed during these 15 second, then the micro controller stops the timer and goes back to monitoring for a crash. If the button is not pressed, then the microcontroller sends a text command to the Bluetooth module. The module then wirelessly texts 911 via the user’s phone.

### Engineering Requirements

**Table 6:** Marketing/Engineering Requirements

Marketing Requirement	Rationale	Engineering Requirement
Compact	Easy to transfer and doesn’t take up space within the car	8”x6”x4”
Easy to Use	Customer Satisfaction and User Experience	Set up time < 1 minute Bluetooth
\$80 MSRP	Affordable – Capture majority of market	Cost to design and manufacture should be less than \$70
Durable	Needs to work even after a car crash	MIL-STD-810 Compliant Included Battery

# Plan of Attack

## Timeline

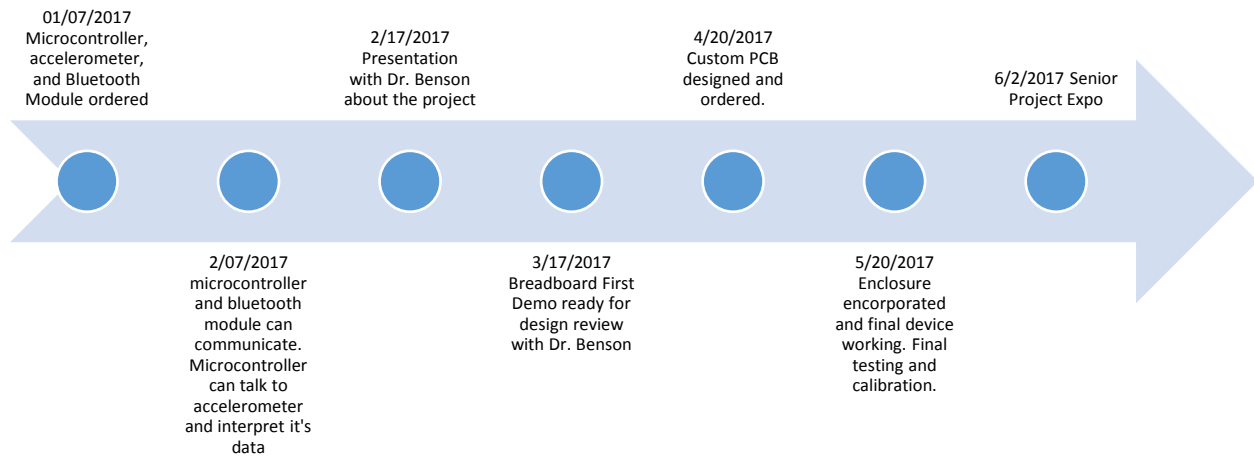

**Figure 9:** Timeline of Major Events

Some potential high risk items are the Bluetooth module, custom PCB, and enclosure. I have not worked with any of these before. The major difficulty with Bluetooth will be connecting it to a phone and making sure it works will all phones. It must work out of the box with Android, iPhone, and even dumb phones. I have never created a custom PCB before so it will take some time for me to learn the software and then I will also need to test and debug the PCB myself. The case I will modify from a standard plastic case. I will need to utilize power tools such as a dermal and drill.

To design the PCB, I will use the program Eagle. It is used by many professionals and a free student version is available. Eagle is powerful enough for what I need to do since my board will not need to incorporate many layers or complex designs.

For the Bluetooth module, I plan to use one with a built-in microcontroller to save space. This will work because I do not need a particularly powerful microcontroller. If the microcontroller has I2C or SPI I will be able to communicate with the accelerometer. I will need a PWM or DAC output of the microcontroller as well so that I can control the speaker. I will first get the micro controller working and then move onto the Bluetooth portion. I will test this systematically. First I will manually connect the device to my phone. Then I will try to push a text command to my phone. Then I will automate the actions and incorporate them into my program.

Overall I will start by creating and testing a prototype on a breadboard first. Once I can get the accelerometer, Voltage regulator, speaker, LED, and button working I can move onto the custom PCB design and enclosure design.

## Detailed Timeline

Task	Start Date	End Date	Duration	Fall 2016										
				Week 1	Week 2	Week 3	Week 4	Week 5	Week 6	Week 7	Week 8	Week 9	Week 10	
Abstract	26-Sep	3-Oct	7	█										
MVP	3-Oct	17-Oct	14		█	█	█							
Marketing Data Sheet	10-Oct	24-Oct	14			█	█	█						
Customer Architeype and Market Research	10-Oct	24-Oct	14			█	█	█						
First Pass Project Report	17-Oct	24-Oct	7				█	█						
Cost Analysis	31-Oct	7-Nov	7					█	█					
Explore Local Start Up Reasources	7-Nov	14-Nov	7						█	█				
Explore the Ethics of Smart Safeguard	14-Nov	21-Nov	7								█	█		
Final Revision and Analysis	14-Nov	28-Nov	14								█	█	█	
Order Parts	28-Nov	12-Dec	14											█

Figure 10: Fall 2016 Gant Chart

Task	Start Date	End Date	Duration	Winter 2017										
				Week 1	Week 2	Week 3	Week 4	Week 5	Week 6	Week 7	Week 8	Week 9	Week 10	
Prototype Micro Controller, LED, Speaker, Accelerometer	9-Jan	30-Jan	21	█	█	█	█							
Prototype Bluetooth (Connect to phone and make a call)	30-Jan	13-Feb	14				█	█	█					
Initial Design Review With Dr. Benson	6-Feb	13-Feb	7					█	█					
Characterize/Test Accelerometer	13-Feb	20-Feb	7						█	█				
Assemble and test full prototype	20-Feb	6-Mar	15							█	█	█		
Design Review with Dr. Benson	6-Mar	13-Mar	7										█	█
PCB Initial Design and Order	6-Mar	20-Mar	14										█	█

Figure 11: Winter 2017 Gant Chart

Task	Start Date	End Date	Duration	Spring 2017										
				Week 1	Week 2	Week 3	Week 4	Week 5	Week 6	Week 7	Week 8	Week 9	Week 10	
Assemble and debug on first PCB	3-Apr	17-Apr	14	█	█	█								
Revise and reorder PCB	10-Apr	24-Apr	14		█	█	█							
Design 3D printed case	17-Apr	1-May	14			█	█	█						
Design and Test Battery System	24-Apr	1-May	7				█	█						
Design Review with Dr. Benson	1-May	8-May	7					█	█					
Asemble and test full system	8-May	29-May	21						█	█	█	█		
Senior Project Expo	2-Jun	2-Jun	0										█	█
Final Report	1-May	9-Jun	39					█	█	█	█	█	█	█

Figure 12: Spring 2017 Gant Chart

The above Gantt charts detail my week by week plan to complete my senior project. I plan to complete all the initial prototyping during winter quarter. This should give me enough time to work out any difficulties that I run into with the design of the electronics. Spring quarter will be reserved for debugging the PCB, building the hard-shell case, the battery circuit, as well as testing the system in the final assembly. I have given myself a month to complete my final senior project report. I also plan to take detailed notes in a lab notebook so that when I need to refer to any of my past work it will be readily available in one place.



**Figure 13** above showcase the Electrical schematic of Smart Safeguard. 12V is externally input into the device. It is immediately converted into 5V by the 7805 linear voltage regulator. The 5V then supplies power to the ATMEGA328P, The HC-06 Bluetooth Module, and the Adafruit GPS Module. The ADXL327 is powered by a 3.3V linear regulator onboard the GPS module. The ATMEGA328, being the brains of the device, is at the center. It utilizes a UART connection to send and receive data to the HC-05 Bluetooth module and the GPS module. The microprocessor also monitors the voltage from the X, Y, and Z axis of the accelerometer through three of its analog input pins. The microprocessor additionally controls the red crash LED, green GPS lock LED, and the crash buzzer. It does not need any additional ICs to control them. After the schematic was designed and verified on a breadboard I moved on to laying out the board on EAGLE CAD.

### Hardware - Layout

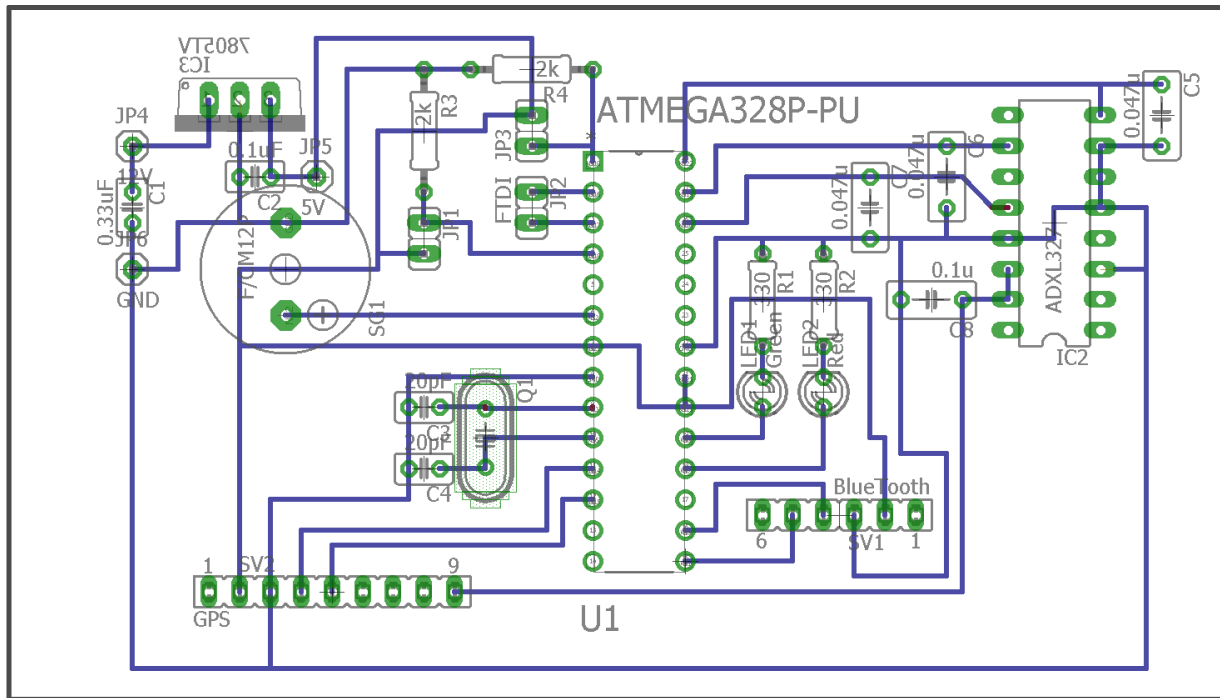

**Figure 14:** Smart Safeguard PCB Layout

**Figure 14** above shows the layout of the PCB that will be used in smart safeguard. I designed the PCB with the intent to get it fabricated using the milling machine in the IEEE room on campus. This limited me to at most a two-layer board due to the limitations of the milling machine. I decided to design a one-layer board because the I was primarily using through hole components and the leads could easily touch the copper of the wrong side on a two-sided board. I started the layout by moving the ATMEGA328 to the center of the board because it connects to almost every other component and an equal number of its right and left pins are utilized. After placing the 328 I moved the 7805 voltage regulator to the top left corner, this was because I need to connect the 12V power to this and I want that to happen as close to the edge of the board as possible. I then moved onto the ADXL327 Accelerometer. This part proved difficult due to the 4 capacitors that also needed to be connected to it. I had to route the XOUT of the accelerometer below the capacitor between the YOUT pin and ground to make the connection with the 328. Once that was completed I moved onto the LEDs and accompanying resistors. These were placed as close to the 328 as possible to make space for the other components. I decided to finish up the right side by placing the Bluetooth module close to the bottom of the 328. I had to rout one of the data



connections under the LED resistors to make the connection to the 328. The left side of the board proved to be much easier than the right. After placing the crystal, FTDI header, and Reset headers I had plenty of room left for the GPS module and buzzer. **Figures 15 and 16** below show the finished product.

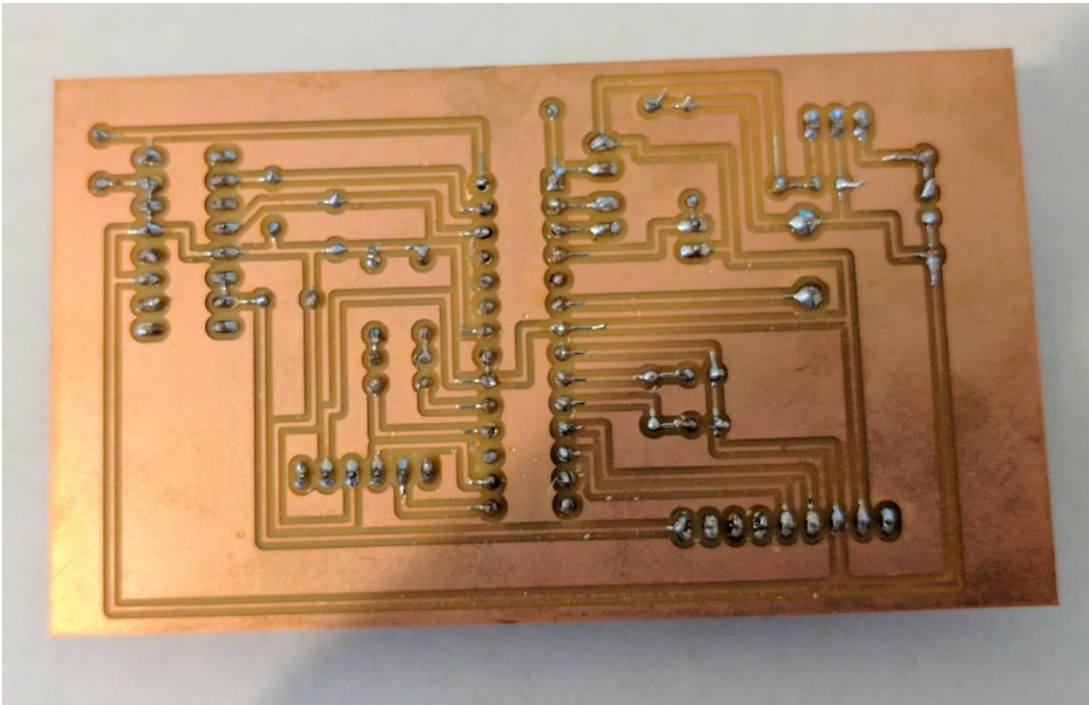

Figure 15: Custom PCB Traces (bottom)

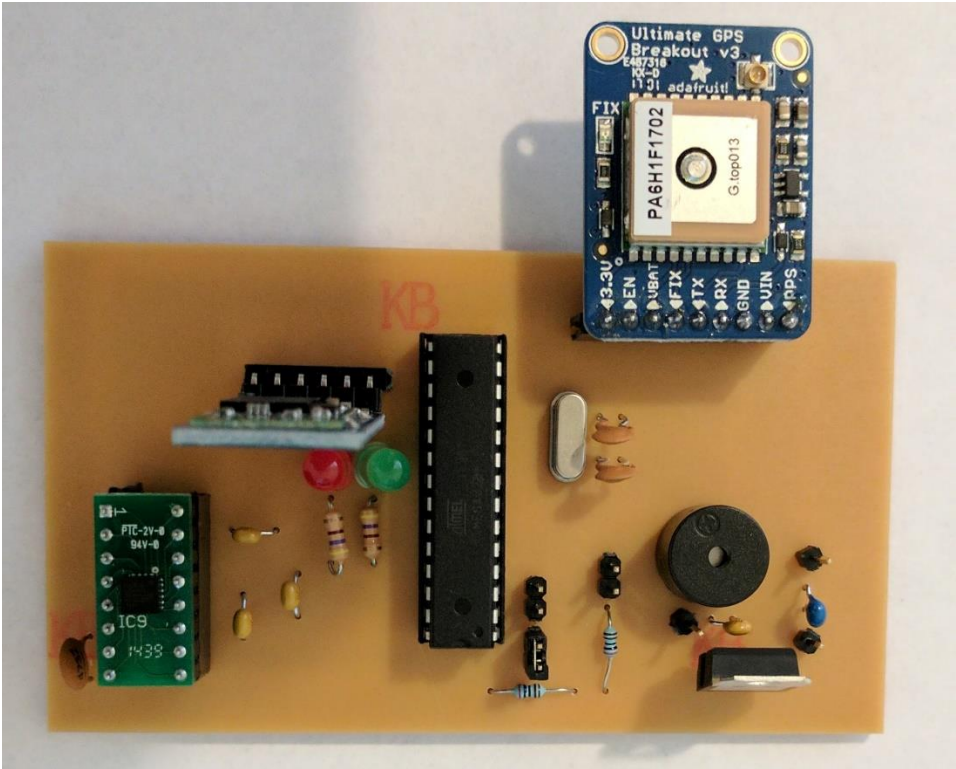

Figure 16: Custom PCB Components (Top)

# Software – Accelerometer Calibration

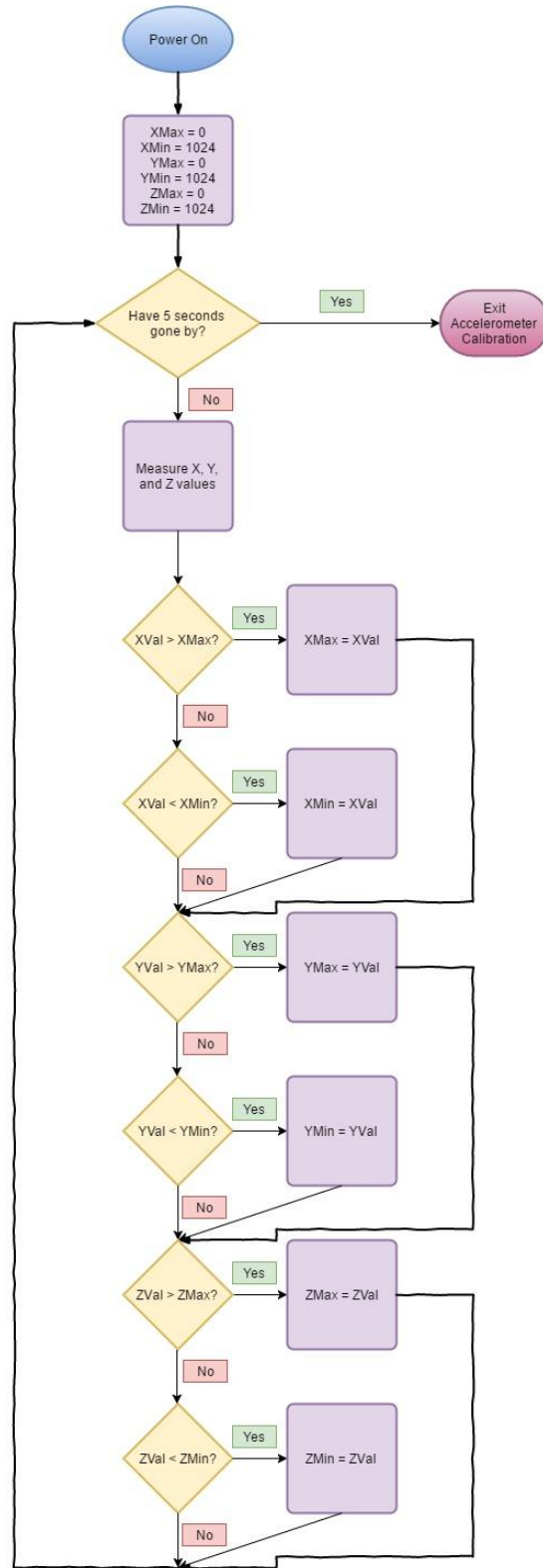

Figure 17: Accelerometer Calibration Flowchart

Because the accelerometer will have an output voltage of about 1.5V when there is no movement I needed a way to filter out that DC value when measuring the X, Y, and Z values. I utilized the Arduino sensor calibration technique highlighted here <https://www.arduino.cc/en/tutorial/calibration>. For the first 5 seconds after the device powers on the device measures the values present on the X, Y, and Z outputs. Each time it compares them to the previous recorded maximum and minimum values. If the value is higher than the maximum then the maximum value is updated to the new value. If the value is lower than the minimum then the minimum value is updated to the new value. This allows the program further down the line to measure acceleration by looking at how far higher than the maximum value or smaller than the minimum value the output is.

### Software – Main Loop

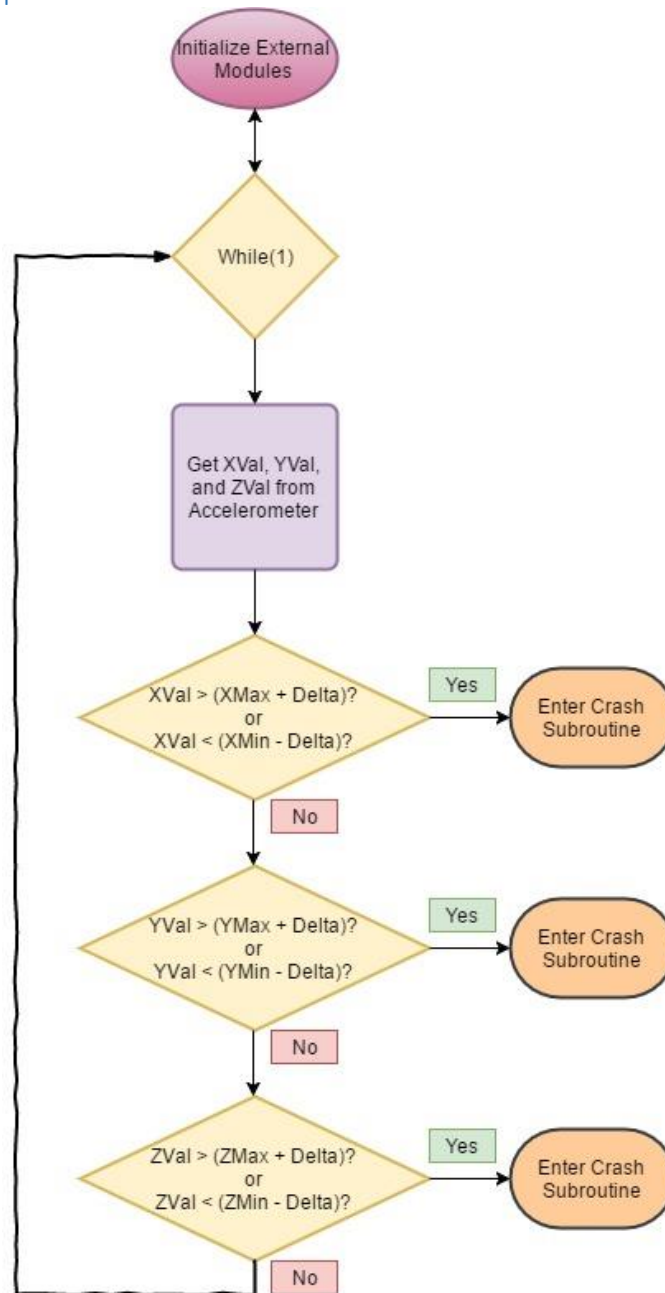
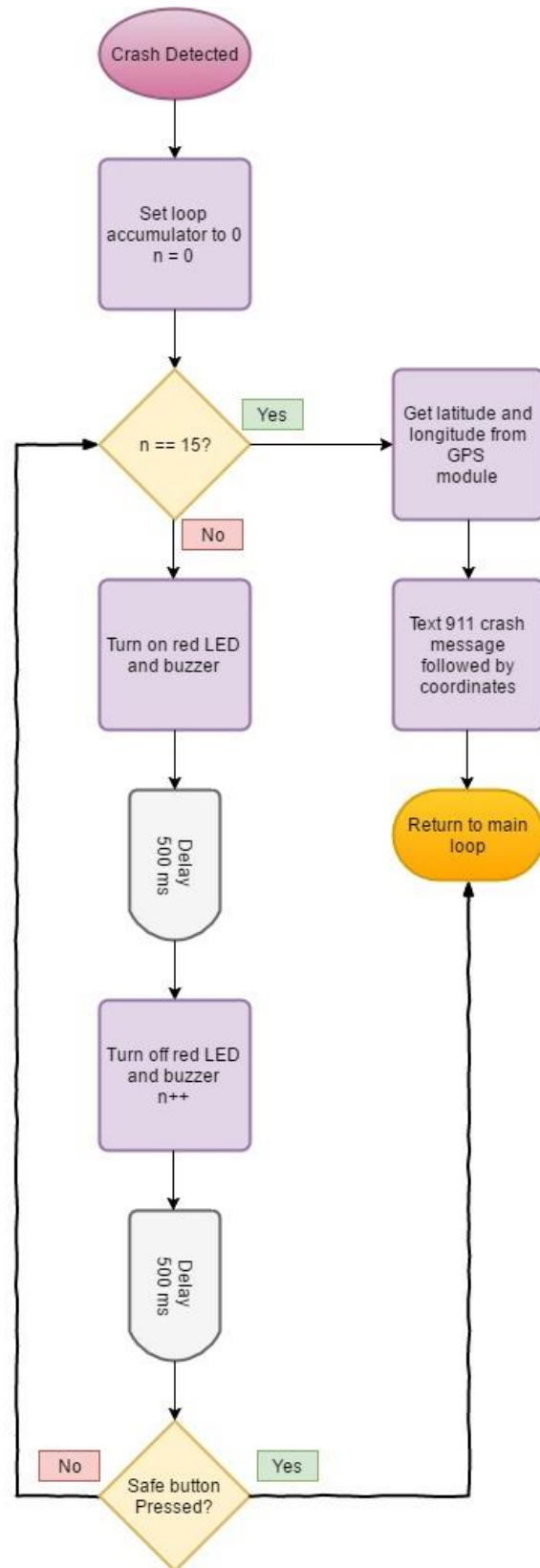

Figure 18: Smart Safeguard Main Loop Flowchart

## Software – Crash Detected Subroutine



**Figure 19:** Crash Detected Subroutine Flowchart

**Figures 18 and 19** above show the main loop software flow diagram as well as the crash detected subroutine software flow diagram. The main loop starts by converting the X, Y, and Z accelerometer voltage outputs into a digital number. The number is then compared with the smallest no movement value minus the delta as well as the largest no movement value plus the delta. If the measured value is outside of the range then a crash is detected and program enters the crash detected subroutine. In the crash detected subroutine the processor loops 15 times. In each loop an LED and buzzer are turned on for half a second and then off for half a second. If the false alarm button is pressed during these 15 loops then the processor exits the subroutine and returns to monitoring the accelerometer values. If the button is not pressed during the 15 iterations of the loop then the processor communicates with the GPS module to receive the longitude and latitude of the Smart Safeguard. Then a text command is sent through the Bluetooth device to the users phone which alerts the authorities of the crash and the location of the accident.

## Testing and Verification

To test and verify the Smart Safeguard I plan to test each individual Engineering Requirement.

To verify that each Smart Safeguard is **compact** and portable they will each be measured and must be 8"x6"x4" within 0.05 inches on each side. To ensure that the Smart Safeguard is **easy to use** each smart safeguard will be powered on and paired with a phone. The process must take less than 3 minutes. The total cost to design and manufacture the smart safeguard must be less than \$70 per device. This will ensure that the Smart Safeguard is affordable for everyone. To ensure **robustness** Smart Safeguard must pass the following MIL-STD-810 tests: Acceleration, Vibration, Shock, and pyroshock. If the Smart Safeguard can pass these I have confidence that it will survive most car crashes for long enough to send a text message.

The Smart safeguard will utilize the Hammod 1554F Project Box. It is a plastic box with dimensions 4.72" x 3.54" x 2.36". These dimensions are within the required dimensions to be considered **compact**.

Pairing the device with a phone via Bluetooth takes less than 30 seconds and after it has been paired initially Smart Safeguard will automatically connect to the phone when it is in range. Connecting the device to the Arduino SMS app takes around 15 seconds. The total setup time is well under 1 minute.

Sadly there is no affordable way to test the MIL-STD-810 standards that I would like to specify. However, if I had a larger budget I would like to explore a Clark testing chamber to test the Smart Safeguard for the MIL-STD-810 ruggedness standard. The test machines can be customized to include the durability and shock testers. Initially I would outsource the testing to Clark Testing, however when my company grows and more units need to be shipped I will invest in one of their testers to test the products in house and lower test cost.

To test the accelerometer I have connected an oscilloscope to the accelerometer outputs. This allows me to look at the voltage differences for any movements of the device that I can make with my hand.

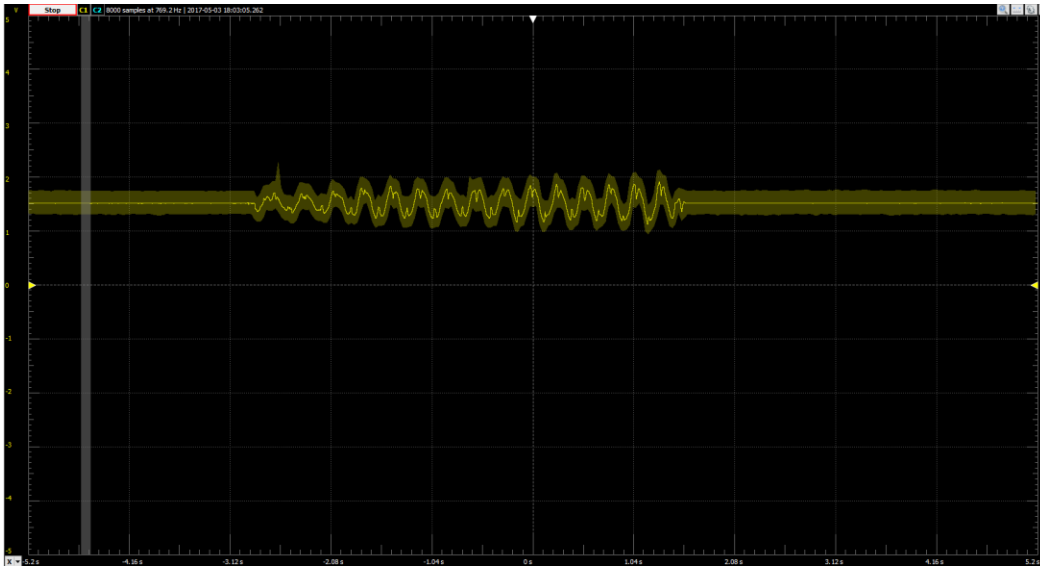

**Figure 6:** Accelerometer Test shake X-Axis

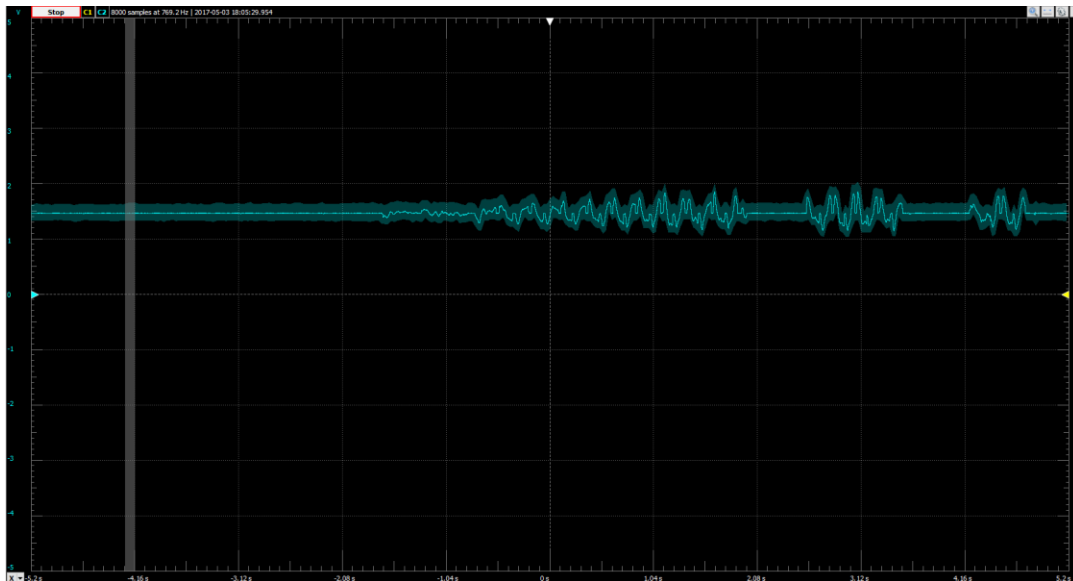

**Figure 7:** Accelerometer Test Shake Y-Axis

**Figures 7 and 6** above show the oscilloscope readings for a slight shaking of the accelerometer. This shows the voltage swings from 1V to 2V while staying constant at 1.5V with no movement. Using the Arduino's onboard 10-bit ADC with a reference voltage of 5V we should expect to see a digital number swing of about 100. To test this, I connected the X, Y, and Z outputs of the accelerometer into pins A3, A4, and A5 of the Arduino. I then wrote a simple test script to send the value measured on those pins to the serial terminal. **Figure 8** below shows the output of the terminal when I sampled the accelerometer X output at 10 times a second.

```
Accel X:257
Accel X:256
Accel X:256
Accel X:255
Accel X:255 ← Shaking Starts
Accel X:276
Accel X:277
Accel X:246
Accel X:284
Accel X:264
Accel X:255
Accel X:299
Accel X:255
Accel X:257
Accel X:300
Accel X:259
Accel X:253
Accel X:277 ← Shaking Ends
Accel X:258
Accel X:256
Accel X:256
Accel X:255
Accel X:254
Accel X:253
Accel X:253
Accel X:253
Accel X:253
Accel X:254
```

**Figure 8:** Accelerometer X-Axis Test Output

From **Figure 8** we can see that the accelerometer outputs a value around 255 when no movement is occurring. When I began to shake the device, the output maxed out at 300. Which is a significant change. This gave me an idea of what kind of noise the Arduino should expect in normal operation on a bumpy road or while the car is going over a pothole.

I plan to bring the device into my car and view how the number changes for a quick acceleration and quick deceleration.

## Test Results

Component Under Test	Test Description	Spec	Reported Value
LM7805 Voltage Regulator	Put 9V on the input of the LM7805 voltage regulator and measure the output voltage	4.9 – 5.1 (V)	4.995V
Bluetooth Module	To test the speed of connectivity I turned on the smart safeguard and pushed the connect button the Arduino SMS app. I then started a stop watch and measured the time it took to connect.	5 seconds max	Less than 1 second
GPS Module	To ensure accurate coordinates, the GPS module should report coordinates that are within 30 feet of the location of the Smart Safeguard.	30 ft. Difference Max	25 ft. Max Difference Recorded
Accelerometer	To test the accelerometer without crashing a car I placed the smart safeguard on top of a RC Car and crashed it multiple times. For serious crashes in which the Smart Safeguard fell off I recorded whether or not the Smart Safeguard detected a crash. I repeated this test 10 times.	9/10 Serious Crashes Detected Minimum	9/10
Durability	Similarly to the accelerometer test procedure, I placed the smart safeguard on an RC car and crashed it multiple times. Each time I observed the effects on the Smart Safeguard. No damage should be done that could compromise the structural or electrical integrity of the car.	Scratches and skid marks ok.	Minor scratches, PCB and components held up fine.
Power Draw	To measure the power draw of the system I connected the input of the LM7805 to a lab bench power supply. I then powered up the supply and set the voltage to 12V. I then recorded the current on the supply meter.	500mA or less	70-80mA
Size	I utilized a ruler to measure the dimensions of the smart safeguard container.	Smaller than 8"x6"x4"	4.724" by 3.54" by 2.362

**Table 8:** Test Procedures and Description

**Table 8** shows the 6 tests that I used to verify my Smart Safeguard project. Each test ensures that the smart safeguard can operate correctly and provide the user with an excellent experience. The rightmost column discusses the results of my tests. Results highlighted in green are within the specification, while results highlighted in yellow are right on the specification. The Smart Safeguard exceed or met all specifications.



# Analysis of Senior Project Design

Project Title: Smart Safeguard

Student's Name: Stephen Marrone

## Summary of Functional Requirements

Smart Safeguard is a car crash detection and first responder notification system. It plugs into the user's car via the 12V cigarette lighter port. The user will connect their phone to the system via Bluetooth. The system continuously monitors data from an accelerometer within it. Once a car crash is detected the system will flash a light and play an alarm sound from a speaker. If the user does not push a button within 15 seconds, the Smart Safeguard will text the location to 911 via the user's phone. If the user does push the button, then Smart Safeguard will not text 911. The smart safeguard is designed to withstand the most destructive car crashes.

## Primary Constraints

I had to design a custom PCB that was not only small but also durable. The PCB was limited to a single layer PCB due to the constraints of the on campus Other Mill Milling Machine. The outer casing must also be very durable because it must protect the sensitive electronics inside from the harshness of a car crash. Another major constraint was the Arduino SMS app that I used. This app allows a microcontroller to send texts through an Android phone and a Bluetooth module. Because of the way the app works the character "/" could not be sent in a text. Thus, limiting the sending of URLs since many of them require the character "/".

## Economic

Initially I estimated the cost of the hardware to be \$25, however the finished product ended up costing \$68. Most of this cost was the GPS module. To cut cost a custom GPS module could be designed. The major equipment needed to manufacture the device is a PCB milling machine, the cost of using a 3<sup>rd</sup> party machine is factored into the PCB price in the BOM. I predicted correctly that the Smart Safeguard would take 6 months to come up with a minimum viable product. The project will be financed initially via early investors. After the first group of products are produced the device will start to bring in revenue to the company and the Smart Safeguard will be self-sustainable. Manufacturing cost are not too high because the PCB is small and there are few components. Most of the cost to produce the device will incur during testing. Among the general functionality of each part within the device the whole system will need to be tested for MIL-STD-810 durability compliance. This is a specific type of testing that will require expensive equipment and thus cost more money to perform.

## Commercial basis

I estimate that 50,000 devices will be sold in the first year, and that number will double the year after. The estimated manufacturing cost of each device is about \$50 assuming parts are purchased in bulk. The Smart Safeguard will cost \$80 per device allowing \$10 per device for advertisement and shipping. The estimated profit per device will be \$20 with a first year's profit of one million dollars.

Smart Safeguard will be bought by individual customers usually one or two at a time. The device will likely not need to be replaced for a large amount of time due to there being no moving parts and low cost of breaking. To sell many devices initially I will sell to large stores such as Target, Walmart, and Amazon.

## Environmental

The smart safeguard has little direct effect on the environment. The device uses little power so vehicles should experience no decrease in mileage. The production of the PCB and all of the components will negatively affect the environment because they are produced in factories that produce waste and greenhouse gasses.

## Manufacturability and Sustainability

The Smart Safeguard will be easy to manufacture. The device has a small custom PCB and a small plastic casing. The PCB will be handled by an external vendor and the plastic casing will be purchased from a vendor. Each component can be easily attached to the PCB via a pick and place machine.

The Smart Safeguard is sustainable to manufacture. The major electronic components are not close to their end of life and the others are generic and easy to replace. The device can be upgraded by improving durability and the Bluetooth module. The module directly effects pairing time and range.

## Ethical

The Smart Safeguard has little to no negative ethical considerations. The whole purpose of the device is to increase the chances of surviving a car accident. Users of this device will have a smaller chance of dying from an automobile accident compared to those who do not. The Smart Safeguard can indirectly harm a person if the device is faulty and goes off without a car accident the flashing lights and loud speaker could cause the driver to be distracted and ironically lead to a car accident.

The components that make up the Smart Safeguard will be purchased via ethical companies that comply with the ethical standards placed upon them by their home countries.

## Health and Safety

The Smart Safeguard will be manufactured by OEMs that comply with their governments Health and Safety policies. The device is small and the electronics are low voltage, however the device will include a small battery. It is important that the battery is well monitored and kept safe. If the battery is overcharged, then it may expand or explode. This can cause harm to any people near the compromised battery. It also may distract a driver and cause them to crash. Because of the nature of this device the highest quality batteries will be used along with the most conservative charging circuits.

## Social and Political

There are no social or political aspects of the Smart Safeguard.

## Development

Development will be focused on user experience, durability, and low cost. Using Bluetooth will make for a good user experience because many phones have Bluetooth capabilities. The Smart Safeguard will comply with the standards defined by IEEE. Durability will be achieved using a high-quality plastic casing and extensive testing. Smart Safeguard will comply with the shock portions of the MIL-STD-810 standards.

## References

[1] Guilford, Dave. "Not Satisfied with OnStar's Steady Profits, GM Wants to ..." *Autonews.com*. N.p., 27 May 2013. Web. 22 Oct. 2016.

Available: <http://www.autonews.com/article/20130527/OEM/305279958/not-satisfied-with-onstars-steady-profits-gm-wants-to-create-a-global->

Description: Guilford analyzes OnStar's current state (as of 2013) and predicts what it can become based on its current market share, profits, and what GM predicts. He predicts that OnStar will remain a big player in the security and crash notification system, but they will expand into streaming entertainment and enhanced diagnostics. Analysts say that OnStar must offer prices that compete with car companies that allow users to use their cell phone plan.

[2] Luchter, Stephen, Andrew Smith, and Jing Wang. "Fatal Injuries in Light Vehicle Crashes - Time to Death ..." *Fatal Injuries in Light Vehicle Crashes - Time to Death and Cause of Death*. N.p., n.d. Web. 22 Oct. 2016.

Available: <https://www.ncbi.nlm.nih.gov/pmc/articles/PMC3400203/>

Description: This academic journal analyzes data from FARS and NASS regarding time and cause of death for motor vehicle fatalities. Luchter, Smith, and Wang found that 46% of deaths occurred within 30 minutes of the accident and they go into death explaining the type of injury. The author's compare their findings to a model called the Trunkey tri-modal.

[3]"Road Crash Statistics - ASIRT." *Road Crash Statistics*. N.p., n.d. Web. 22 Oct. 2016.

Available: <https://asirt.org/initiatives/informing-road-users/road-safety-facts/road-crash-statistics>

Description: This website has an abundant amount of useful statistics regarding car accidents, including annual fatalities, injury amounts, and cost. There are statistics published for both the United States and worldwide. The website is published by the Association for Safe International Road Travel (ASIRT).

[4]"Section 23. Transportation - Census." *Section 23: Transportation*. N.p., n.d. Web. 22 Oct. 2016. Available:

<http://www.census.gov/library/publications/2011/compendia/statab/131ed/transportation.html>

Description: The transportation section of the U.S. census provides an abundant amount of data regarding transportation in the U.S. I used the data from the "Motor Vehicle Accidents and Fatalities" section. The data shows how many Americans died from motor accidents, the type of person (pedestrian, driver, passenger, etc.), as well as what percentage of accidents were fatal.

Instruments, Texas. "UA7800 Series Positive Voltage Regulators." *UA7800 Series (Rev. J)*(n.d.): n. pag. *Sparkfun*. May 1976. Web. 5 Apr. 2017.