

Portable DAC and Headphone Amplifier for High Impedance Headphones

Designer: Kevin Vinh-Khang Thai

Electrical Engineering Senior Project
California Polytechnic State University
16 June 2017

Chapter 1 Table of Contents

List of Figures	4
List of Tables.....	5
Abstract	6
Chapter 1 Introduction.....	7
Motivation	7
Necessity for a DAC	7
High Impedance Headphone Explanation	7
Necessity for an Amplifier	8
Headphone Sensitivity with Power	9
Chapter 2 Customer Needs, Requirements and Specification.....	10
Customer Needs Assessment	10
Marketing Requirements and Engineering Specifications.....	11
Chapter 3 Functional Decomposition.....	12
Level 0 Functional Decomposition	12
Level 1 Functional Decomposition	13
Chapter 4 Project Planning.....	14
Winter Quarter Gantt Chart (Planned).....	14
Winter Quarter Gantt Chart (Planned with Actual Timeline).....	15
Spring Quarter Gantt Chart (Planned).....	16
Spring Quarter Gantt Chart (Planned with Actual Timeline).....	17
Estimated Costs of Manufacturing	18
Estimated Cost for Design	19
Chapter 5 Design.....	20
Overall System.....	20
Signal Path	21
Battery Management.....	27
Power	28
Chapter 6 Construction	30
Layout and Printed Circuit Board.....	30
Top Layer	30
Bottom Layer	31
Unpopulated Board	32
Fully Populated Board with Battery.....	33
Enclosure (Planned, but never achieved).....	34
Chapter 7 Testing.....	35
Breadboard Testing.....	35
No Filter Output	36
LC Filter	37
Final System Measurements.....	38
Power Consumption.....	38
Total Harmonic Distortion	38
White Noise Response	39
Chapter 8 Operation.....	40
Chapter 9 Conclusions and Recommendations.....	41

Conclusions	41
Future Improvements	41
Recommendations for Amateur Designers	41
Chapter 10 Appendix A: Analysis of Senior Project Design.....	42
1. Summary of functional requirements.....	42
2. Primary Constraints.....	42
3. Economic	43
4. If manufactured on a commercial basis	45
5. Environmental.....	45
6. Manufacturability.....	45
7. Sustainability.....	45
8. Ethical	46
9. Health and Safety	46
10. Social and Political.....	47
11. Development	47
Chapter 11 Works Cited	48
Chapter 12 Thank You.....	49

List of Figures

Figure 1: Explanation of DACs [1].....	7
Figure 2: Level 0 Block Diagram	12
Figure 2: Level 0 Block Diagram	13
Figure 3: Level 1 Block Diagram	13
Figure 4: Winter Quarter Gantt Chart.....	14
Figure 6: Winter Quarter Gantt Chart with Actual Timeline.....	15
Figure 5: Spring Quarter Gantt Chart	16
Figure 8: Spring Quarter Gantt Chart with Actual Timeline	17
Figure 9: Full System Schematic	20
Figure 6: Signal Path Schematic	21
Figure 7: PCM2706C Schematic	22
Figure 8: PCM1794A Schematic	23
Figure 13: Transimpedance Device Schematic.....	24
Figure 10: TPA2008D2 Schematic.....	25
Figure 11: LC Filter Schematic.....	26
Figure 12: Battery management schematic.....	27
Figure 17: 3.3 V Bucking Regulator Schematic	28
Figure 18: 5 V Boosting Regulator Schematic	29
Figure 19: Top Layer PCB Layout	30
Figure 20: Bottom Layer PCB Layout.....	31
Figure 21: Unpopulated Board.....	32
Figure 22: Final Product with Battery	33
Figure 13: Full Enclosure Isometric Model Measurements 1	34
Figure 14: Full Enclosure Isometric Model Measurements 2	34
Figure 25: Breadboard with Crucial Signal Path	35
Figure 13: Class D Output with 0 V Input.....	36
Figure 14: Low Pass Filter Model Schematic	37
Figure 15: Output Filter Frequency Response	37
Figure 29: Total Harmonic Distortion Measurement.....	38
Figure 30: White Noise Input Response	39
Figure 31: Typical connection	40

List of Tables

Table 1: Measured iPhone 6 audio specifications [12]	9
Table 2: OSHA Permissible Noise Exposure [6]	9
Table 3: Customer requirements and reasoning	10
Table 4: Marketing Requirements and Engineering Specification	11
Table 5: Level 0 Function Table	12
Table 6: Level 1 Function Table	13
Table 7: Bill of Materials	18
Table 8: 2706C Module Description	22
Table 9: PCM1794A Module Description	23
Table 10: Transimpedance Device Module Description	24
Table 11: TPA2008D2 Module Description	25
Table 12: LC Filter Module Description	26
Table 13: Bill of Materials	44

Abstract

The following paper contains an in-depth report on the design process of a portable DAC and Amplifier for high impedance headphones. The project brings portability into an audiophile's world. This portable DAC and Class D amplifier takes USB data from a phone, converts it to analog, and amplifies the signal for high impedance headphones. First, the document contains motivations for the project: such as the necessity for such equipment, and who would use this product. Next, discussions of marketing considerations and customer needs bring together specifications. After, the report examines the project plan, overall functionality blocks, and estimated costs. Finally, the last chapter discusses a full description on each part of the product.

Chapter 1 Introduction

Motivation

For many people who love audio, the problem of portability exists. Audiophiles prefer and have enthusiasm for high fidelity audio reproduction. They prefer buying higher grade audio equipment, and take the sound that goes into their ears very seriously. Because of this, audiophiles may choose to have higher quality headphones, with high quality headphone amplifiers, and high quality digital to analog converters (DAC). High quality DAC's and amplifiers tend to consume a lot of power and require much effort to move. One cannot easily carry these around daily, and most likely sit on desktops for their lifetime. This project addresses the problem of portability for audiophiles. The device implements an external DAC and headphone amplifier takes the digital audio from a phone or laptop's digital port (USB-laptop or Android, Lightning-iPhone), convert the digital audio to analog, and amplify for high impedance headphones. The device can fit in a pocket, and a battery powers it.

Necessity for a DAC

A DAC plays an integral part of the audio path. Because the world connects runs digitally, almost all music is stored and retrieved digitally, nowadays. A DAC [Digital-to-Analog Converter] converts digital audio information (discrete time, and discrete levels) into an analog audio signal (continuous time, and continuous level signal) [1]. Humans perceive the world through analog signals. Figure 1 shows that more accurate reproduction of analog signals requires higher sampling rate and bitrates. The more bits (related to the levels of magnitude), the more accurate the magnitude of signal. The faster the sampling rate: the more accurate the time resolution. The device an upgrades the current internal DACs available on phones.

High Impedance Headphone Explanation

Most headphone buyers ignore the impedance specification, but it makes a big difference [2]. Headphone impedance measures the electrical characteristic of the headphone's voice coil and magnetic field coupling of the voice coil and magnet inside the headphone [3]. The manufacturing of voice coils in high impedance headphone makes them much thinner, and harder to manufacture than the typical 32-ohm thicker and heavier coils. Because of this, the lighter coils of a high impedance headphone allow the wires to fit tighter, so less air can travel between the windings, and that makes the electromagnetic field of the voice

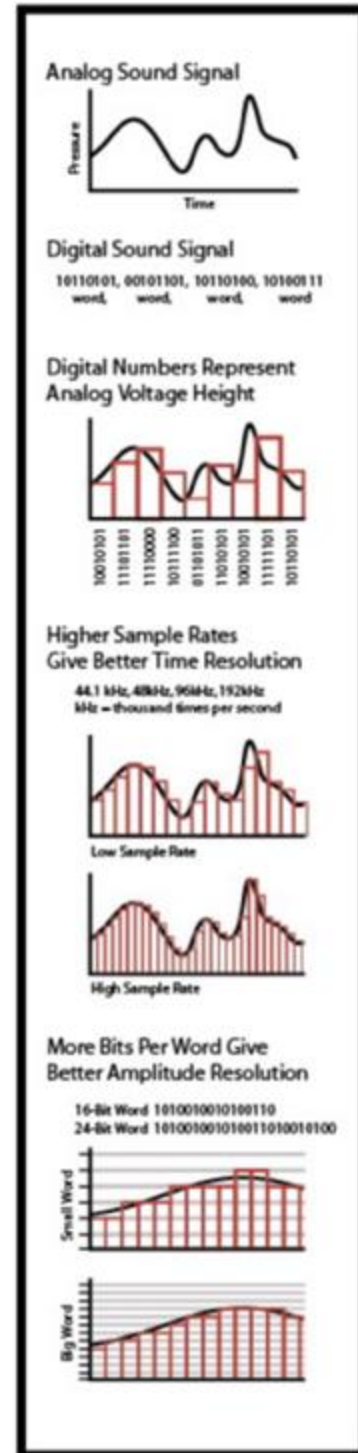

Figure 1: Explanation of DACs [1]

coil stronger. This reduces distortion for the high impedance versions compared with the low impedance headphones.

Necessity for an Amplifier

Higher quality headphones tend to have higher impedances, so the typical portable amplifier on a phone does not supply enough power to sufficiently drive high impedance headphones. A basic relationship of $P = \frac{V^2}{R}$ realizes the necessity for a more powerful amplifier. Keep the voltage (V) constant, and raise impedance (R) due to the headphones, the power production lowers. To increase the power (necessary for louder listening levels), the voltage must increase. However, many mobile phones cannot raise their voltages too high, therefore limiting the power delivered to the headphones. Table 1 shows the specifications measured from an iPhone 6's audio output into different impedance loads. The output power with a 330-ohm load yields much lower power than with the 15-ohm load. Since the 330-ohm load produces much less output power, the 330-ohm load does not produce the same audio levels as a lower impedance speaker. However, the table also shows good news. The higher impedances have higher dynamic range than lower impedance, while higher impedances produce lower total harmonic distortion and noise (THD+N). This further indicates why audiophiles prefer high impedance.

	15 Ohm	33 Ohm	150 Ohm	330 Ohm
Dynamic Range	84.155 dB	92.281 dB	92.223 dB	92.160 dB
THD+N	5.873%	0.0054%	0.0032%	0.0032%
Crosstalk (L)	-49.608 dB	-56.239 dB	-71.721 dB	-77.966 dB
Crosstalk (R)	-49.831 dB	-56.459 dB	-72.191 dB	-77.983 dB
Output Power	44.04 mW	26.39 mW	6.614 mW	3.072 mW
Output Voltage	812.7 mVrms	933 mVrms	997 mVrms	1,007 mVrms
Relative Level (20Hz - 20kHz)	±0.088 dB	±0.088 dB	±0.089 dB	±0.088 dB

Table 1: Measured iPhone 6 audio specifications [12]

Headphone Sensitivity with Power

To put the available output voltage or power into context, the sensitivity of headphones comes into play.

Headphones' sensitivity typically measure dB SPL/Vrms or dB SPL/mW [4]. For example: the Sennheiser HD600 have a 300-ohm impedance, and a sensitivity of 105 dB SPL/Vrms [5].

These headphones have high impedance and normal sensitivity. According to the iPhone 6 specification measurements in Table 1, the phone supplies sufficient power to the headphones for a good listening volume. According to OSHA's (Occupational Safety and Health Administration) standard 1910.95: Occupational Noise Exposure, one should only listen to 105 dB SPL for 1 hour [6].

Duration per day, hours	Sound level dBA slow response
8.....	90
6.....	92
4.....	95
3.....	97
2.....	100
1 1/2	102
1.....	105
1/2	110
1/4 or less.....	115

Table 2: OSHA Permissible Noise Exposure [6]

Although HD 600s provide enough sound level, headphones exist with less sensitivity, and higher impedance. The product must account for all types of high impedance and low sensitivity headphones.

Chapter 2 Customer Needs, Requirements and Specification

This chapter discusses customer needs that turn into goals and specification for the project.

Customer Needs Assessment

To figure out what a customer truly wants, consult with some audiophiles in Cal Poly's AES and online random forums. Table 3 contains an overview of results. This table lists a customer requirement and the reasons behind the customers' thoughts.

CUSTOMER REQUIREMENTS	REASONS
EASE OF USE	<ul style="list-style-type: none">• Customers prefer plug and play• Use minimal buttons and knobs
NO NOTICEABLE SOUND FLAWS	<ul style="list-style-type: none">• Improve on phone amplifiers.• No prominent flaws.• Phone amplifiers do not have noticeable flaws
LONG BATTERY LIFE	<ul style="list-style-type: none">• Battery life should not die before the phone.• Should last hours playing music
PORTABILITY	<ul style="list-style-type: none">• Fit into pocket. Not portable if it does not fit into pocket.
LIGHT WEIGHT	<ul style="list-style-type: none">• If in your pocket, it shouldn't present any burden to carry around

Table 3: Customer requirements and reasoning

Marketing Requirements and Engineering Specifications

MARKETING REQUIREMENT	ENGINEERING REQUIREMENT	DESCRIPTION
USB CHARGING AND USB DATA TRANSFER	<ul style="list-style-type: none"> • Supports USB 2.0 • Charges from Vbus of a micro USB 	<ul style="list-style-type: none"> • Battery manager must charge the battery fully, and safely.
BATTERY POWER	<ul style="list-style-type: none"> • Small 1200 mA-Hr battery • Lithium Ion 	<ul style="list-style-type: none"> • Small and lightweight • Lighter and easier to charge than other battery chemistries
HIGH FIDELITY	<ul style="list-style-type: none"> • DAC 24 bit, 192 kHz • Class D amplifier with flat frequency response up to 20 kHz 	<ul style="list-style-type: none"> • Must produce optimal sound reproduction for the entire range of human listening • Must produce more accurate sound quality than the iPhone 7 [7]
HEADPHONES MUST PLAY LOUD	<ul style="list-style-type: none"> • A 300-ohm load with normal sensitivity of 105 dB SPL/Vrms must produce at least 120 dB SPL 	<ul style="list-style-type: none"> • To give headroom for listeners who prefer loud music, the dB SPL level must go higher than people can tolerate.
MUST NOT BLOW OUT EARS	<ul style="list-style-type: none"> • A cap of 120 dB SPL for 300-ohm 105 dB SPL/Vrms. 	<ul style="list-style-type: none"> • Amplifier limited for reduction of injury to listener [6].
LIGHTWEIGHT AND PORTABLE	<ul style="list-style-type: none"> • All parts must fit on a 2"x 3" PCB 	<ul style="list-style-type: none"> • Use only surface mount chips • Encase both battery and board in an enclosure that shields the PCB from the outside world.

Table 4: Marketing Requirements and Engineering Specification

Chapter 3 Functional Decomposition

This chapter discusses the overall functionality, and signal flow of the project. Chapter 5 contains a more in-depth description on each subsystem.

Level 0 Functional Decomposition

The device takes digital audio signals from either a portable music playing device and converts it to an analog signal, and amplify it to produce a signal that powers high impedance headphones. Figure 3 shows the expected input and output of the system.



Figure 2: Level 0 Block Diagram

MODULE	PORTABLE DAC AND AMPLIFIER
INPUT	Digital music through USB communication
OUTPUT	Analog audio amplified for high impedance headphones
FUNCTIONALITY	The digital data comes from either a phone or computer through USB communication. The device converts this data to an analog signal, then amplifies the signal for use with high impedance headphones.

Table 5: Level 0 Function Table

Level 1 Functional Decomposition

When we look closer into the subsystems of the diagram, a few steps must happen to achieve the final amplified analog signal. The power portion contains a battery management recharges the lithium ion battery from a USB cable. The battery goes through different regulators to provide different signals for digital and analog circuits. The block diagram in Figure 4 shows the power supplies and signal flow.

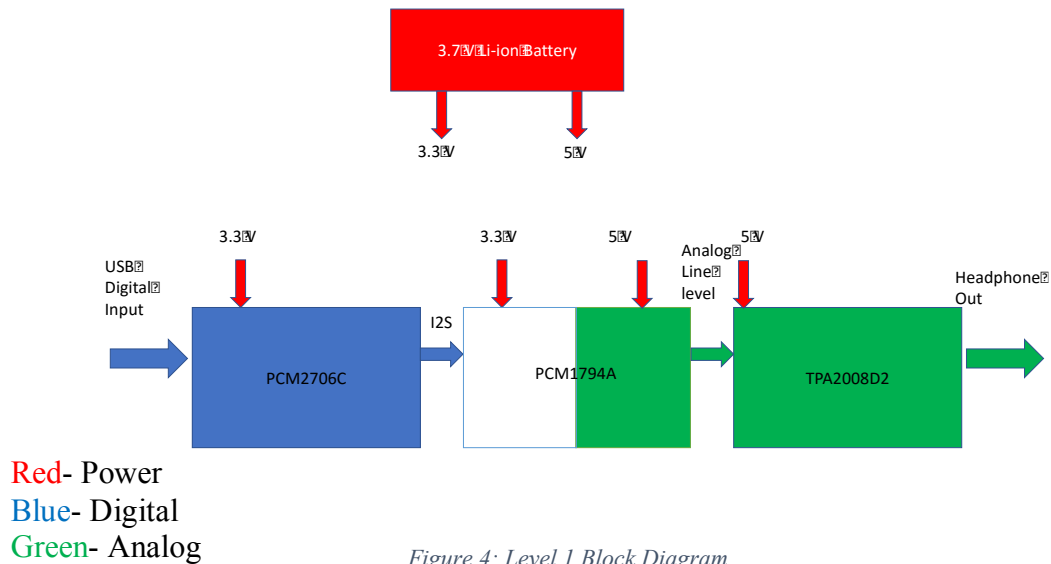

Figure 4: Level 1 Block Diagram

MODULE	PORTABLE DAC AND AMPLIFIER
INPUT	Digital music through USB communication 5 V DC from USB cable (FOR CHARGING ONLY)
OUTPUT	Analog audio amplified for high impedance headphones
FUNCTIONALITY	The power section charges a 3.7 V Li-ion battery. Voltage regulators convert the battery to 3.3 V, and 5 V for the different devices. The digital data comes from either a phone or computer through USB communication. PCM2706C transfers the USB communication to an I2S protocol signal. PCM1794A converts this I2S signal to an analog signal. Lastly, the TPA2008D2 amplifies the signal for sufficient use on high impedance headphones.

Table 6: Level 1 Function Table

Chapter 4 Project Planning

This chapter provides a planned schedule for this project, along with projected costs. A realistic schedule, and actual costs included.

Winter Quarter Gantt Chart (Planned)

Figure 5 shows the Winter Quarter Gantt Chart. For the weeks of 8 January to 5 March, prepare the components for the signal path testing. This includes the USB audio to I2S converter, the DAC, and the amplifier. Finish a working prototype by the week 9 so in case the first prototype does not work.

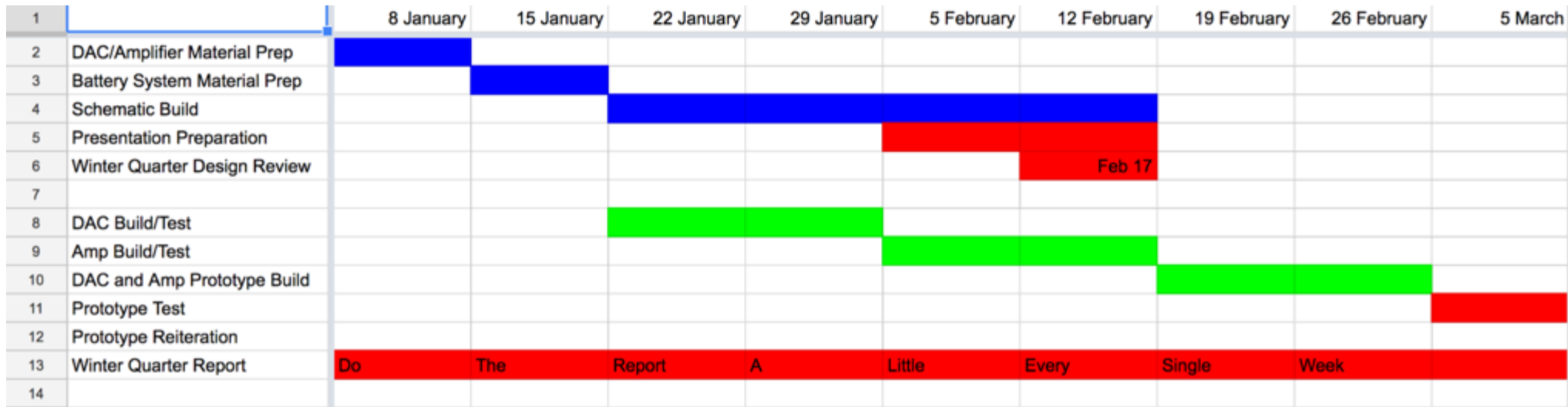

Figure 5: Winter Quarter Gantt Chart

Blue represents schematic and materials preparation.

Green represents build and testing.

Red represents preparation for deadlines

Winter Quarter Gantt Chart (Planned with Actual Timeline)

The original planned Gantt chart from winter quarter overlays the actual timeline.

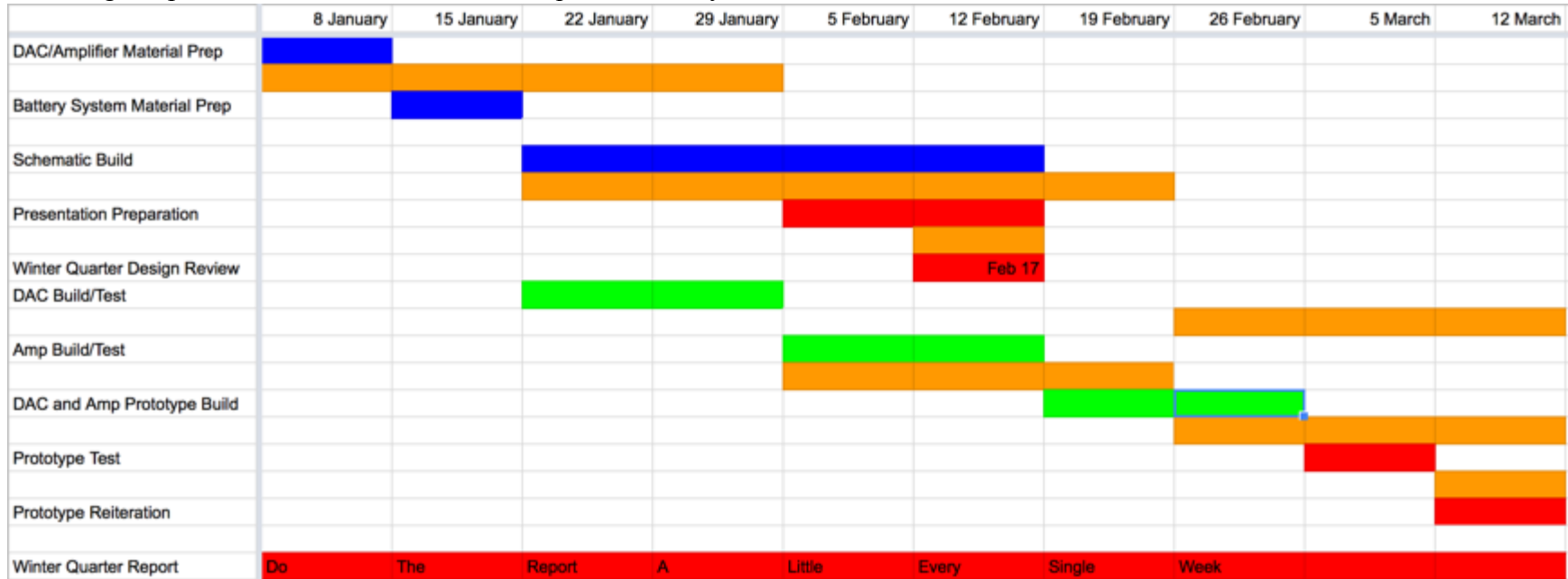

Figure 6: Winter Quarter Gantt Chart with Actual Timeline

Blue represents schematic and materials preparation.

Green represents build and testing.

Red represents preparation for deadlines

Orange represents the actual timeline

Spring Quarter Gantt Chart (Planned)

Spring Quarter starts off with the battery system build and test. After, build a final prototype, and reiterated if necessary. Plan for the housing build and PCB build over a month before the Senior Project Expo to give sufficient room for final testing and reiterations.



Figure 7: Spring Quarter Gantt Chart

Blue represents schematic and materials preparation.

Green represents build and testing.

Red represents preparation for deadlines

Spring Quarter Gantt Chart (Planned with Actual Timeline)

The original planned Gantt chart from spring quarter overlays the actual timeline. Because winter quarter returned no prototype, prototype testing had to continue for weeks into spring quarter. This pushed a final system build dangerously close to the deadline. Housing build never happened.

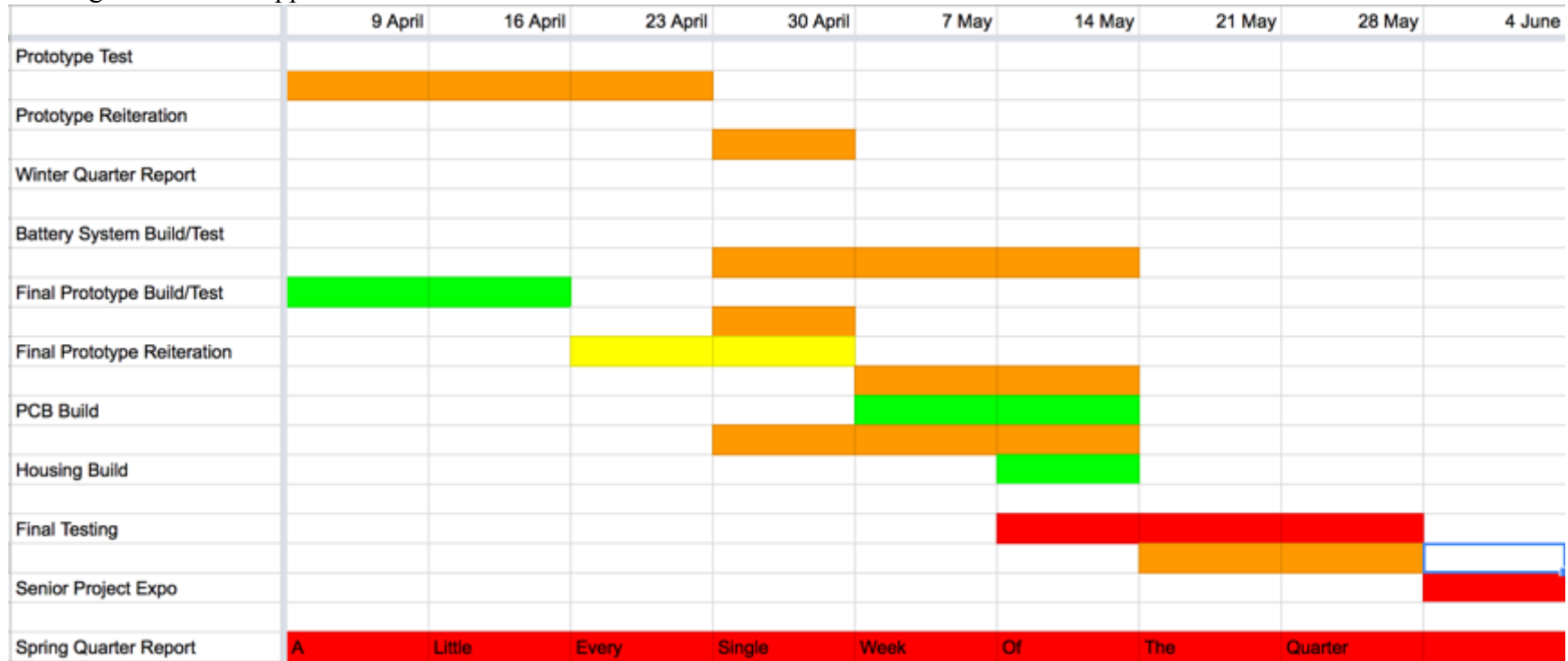

Figure 8: Spring Quarter Gantt Chart with Actual Timeline

Blue represents schematic and materials preparation.

Green represents build and testing.

Red represents preparation for deadlines

Orange represents the actual timeline

Estimated Costs of Manufacturing

Table 7 shows the cost of all the chosen components. However, this does not account for the cost of the housing, bringing the total to \$75. With additional labor costs for manufacturing of about 30 minutes for \$35/hr yield an additional \$17.50.

THE TOTAL FOR MANUFACTURING THIS DEVICE: \$92.50.

Part	Quantity	Manufacturer 1	Part #	Price	Part Total
DAC	1	Texas Instruments	PCM1794A	13.78	13.78
Amp	1	Texas Instruments	TPA2008D2	4.39	4.39
Battery Management	1	Texas Instruments	BQ24092DGQR	1.22	1.22
3.5 mm Audio Jack	1	CUI Inc.	SJ2-35943A-SMT-TR	1.44	1.44
Micro USB port	2	Amphenol FCI	10118192-0001LF	0.46	0.92
Resistors	20	Yageo	-	0.1	2
330 uF Capacitor (Aluminum)	1	Nichicon	UWX0J331MCL1GB	0.231	0.231
Capacitors (Ceramic)	45	Yageo	-	0.1	4.5
Inductor 2.2mH	2	Murata Electronics	LQH43NN222K03L	0.66	1.32
Inductor 0805	2	TDK	-	0.14	0.28
3.7 V 1200 mA-Hr Lithium Ion Battery	1	Sparkfun	LP503562	13.18	13.18
USB Audio to I2S Converter	1	Texas Instruments	PCM2706C	7.41	7.41
10K THERMISTOR	1	Cantherm	MF52C1103F3380	1.86	1.86
3.3 V Buck Regulator	1	Texas Instruments	LM3671MF-3.3/NOPB	0.92	0.92
5 V Boost Regulator	1	Texas Instruments	TPS61222DCKR	1.16	1.16
POT 1.0M OHM	1	Bourns Inc.	3352T-1-105LF	1.53	1.53
Red LED	2	OSRAM Opto Semiconductors Inc.	LS R976-NR-1	0.26	0.52
Switch	1	C&K	JS202011SCQN	0.46	0.46
2"x3" two-layer board	1	OSH Park	-	10	10
12 MHz Crystal Oscillator	1	ECS Inc.	ECS-120-18-5PX-JEM-TR	0.33	0.33
				TOTAL	67.451

Table 7: Bill of Materials

Estimated Cost for Design

To estimate the cost for design, account for the pay rate of an engineer. A wage for an undergraduate electrical engineering student can hover around \$25 per hour. Using Equation 6 from Chapter 10 in Ford and Coulston [8], the wage we determined the wage as:

$$Wage = (50 + 4 \times 25 + 15) / 6 = \$27.5$$

For Fall Quarter (EE 460), dedicate four hours a week to the project. For Winter (EE 461) and Spring (EE 462), dedicate 10 hours a week to this project. Each quarter 10 weeks. THIS ADDS UP TO 240 HOURS OF ENGINEERING DESIGN WORK.

The cost of design includes the multiple parts ordered for prototyping and testing. Triple order each part to total \$207.35. Four chips need a breakout board of \$5 each to prototype. Lastly, shipping costs around \$30 for multiple shipments. THE TOTAL FOR PARTS = \$257.35.

With the engineering labor cost and total part cost added together, the total cost for design estimates \$6779.75

Chapter 5 Design

This chapter provides an examination of the design and motivations behind choosing certain parts.

Overall System

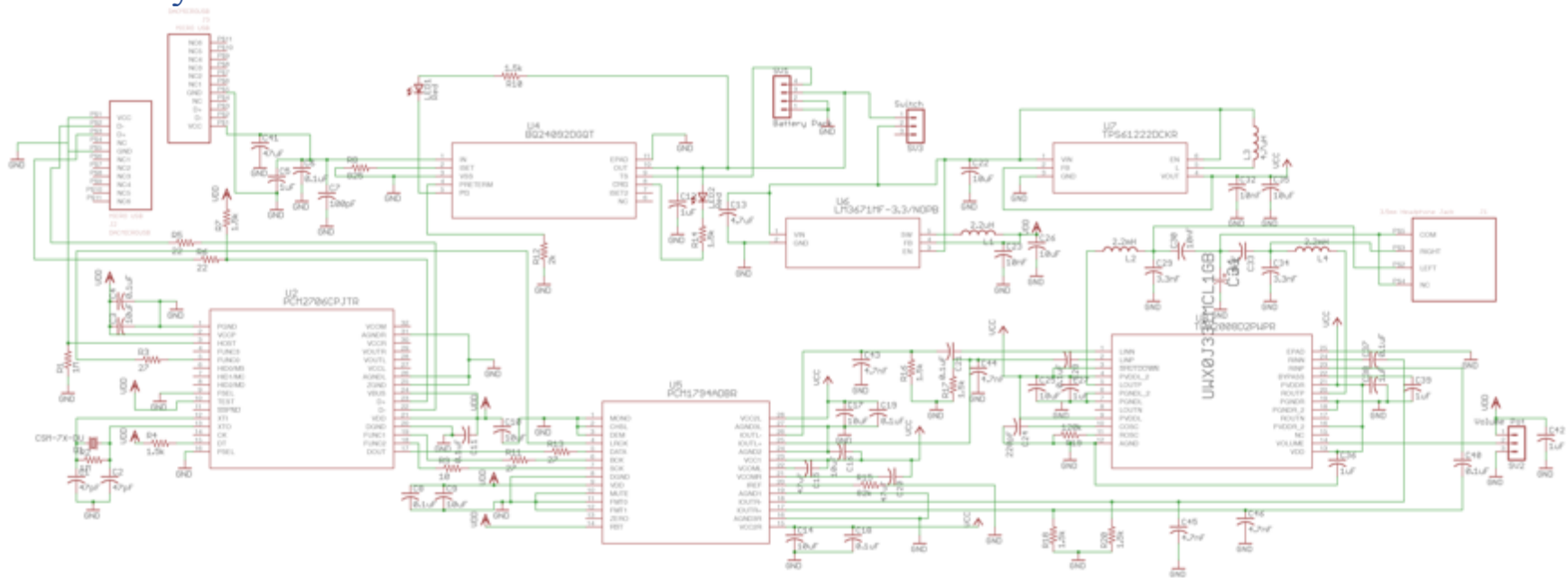

Figure 9: Full System Schematic

Figure 3 and Figure 4 contain a summary of the entire system. Two micro-USB ports, one 3.5 mm stereo headphone jack, a volume knob, and a switch connect the user and board. The audio signal inputs to one micro-USB, and the other for charging. A potentiometer controls the volume by controlling a voltage that sets the gain of the amplifier, and the 3.5 mm stereo headphone jack contains the output of the system. Lastly the switch turns the system on or off.

Signal Path

The signal path starts from the USB port. The D+ and D- of the USB port inputs into the PCM2706C. This converts the USB audio data to either S/PDIF, I2S, or analog out. The I2S lines feed into the PCM1794A DAC. Current outputs to a transimpedance device that converts current into voltage. Lastly, that voltage outputs the Class D amplifier. The output passes through a passive LC low pass filter that also acts as a differential to single ended output.

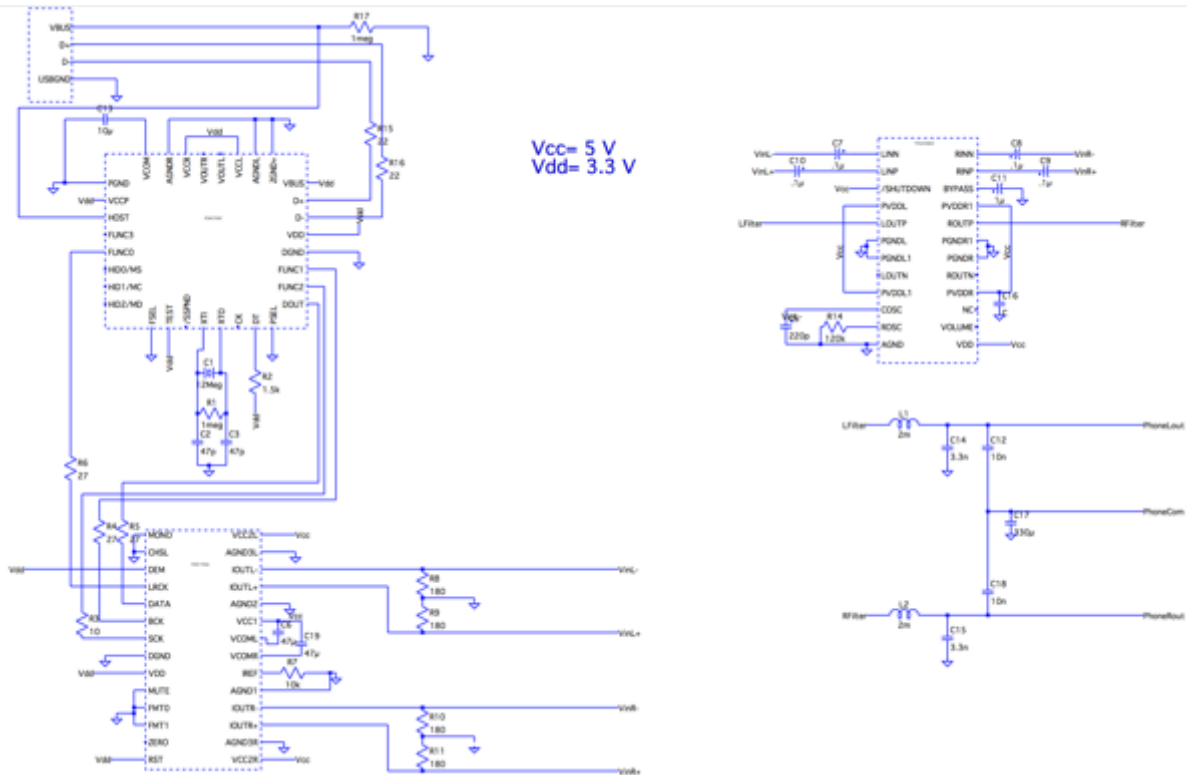

Figure 10: Signal Path Schematic

PCM2706C	
MODULE	USB Audio to I2S converter
INPUT	USB Audio
OUTPUT	I2S
DESCRIPTION	The USB interface takes USB Audio data and converts to either analog, S/PDIF, or I2S
REASONING AND IMPLEMENTATION NOTES	<p>-Bypass the DAC because the DAC only converts 16 bit, and 48 kHz. This does not improve over current DAC's inside of portable devices</p> <p>-Choose I2S over the S/PDIF because the clocks separate from each other, and the communication only relies on one master clock. Theoretically, this should reduce the jitter for high frequency sampling because the chips treat the master clock more carefully than the other clocks [9].</p> <p>-Configure the chip to operate on a 3.3V supply instead of the 5 V Vbus supply from the USB</p>

Table 8:
Module

2706C
Description

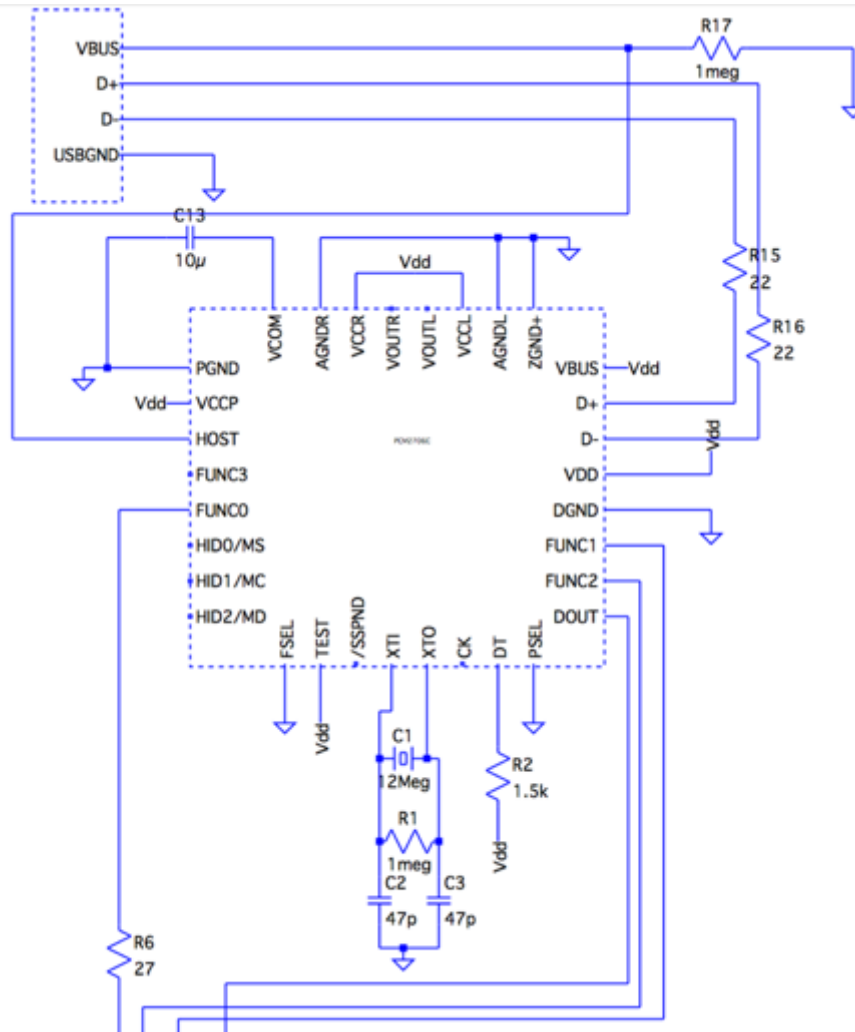

Figure 11: PCM2706C Schematic

PCM1794A	
MODULE	DAC
INPUT	I2S
OUTPUT	Analog current
DESCRIPTION	24-Bit, 192-kHz Sampling, Advanced Segment, Audio Stereo Digital-to-Analog Converter
REASONING AND IMPLEMENTATION NOTES	<p>-This DAC has a lack of line drivers. Ideally, line drivers only interface between different systems. They have a relatively high voltage (~2 Vrms) and a high impedance as to not draw current. The next stage contains an amplifier, so the DAC does not need to produce 2 Vrms. Avoiding line drivers improves efficiency because the signal does not need attenuation.</p> <p>-This DAC has the lowest THD+N specification with the highest bitrate and sampling rate of all the readily available DACs.</p> <p>-Many expensive DACs for professional audio implementations cost too much and require special ordering.</p>

Table 9: PCM1794A Module Description

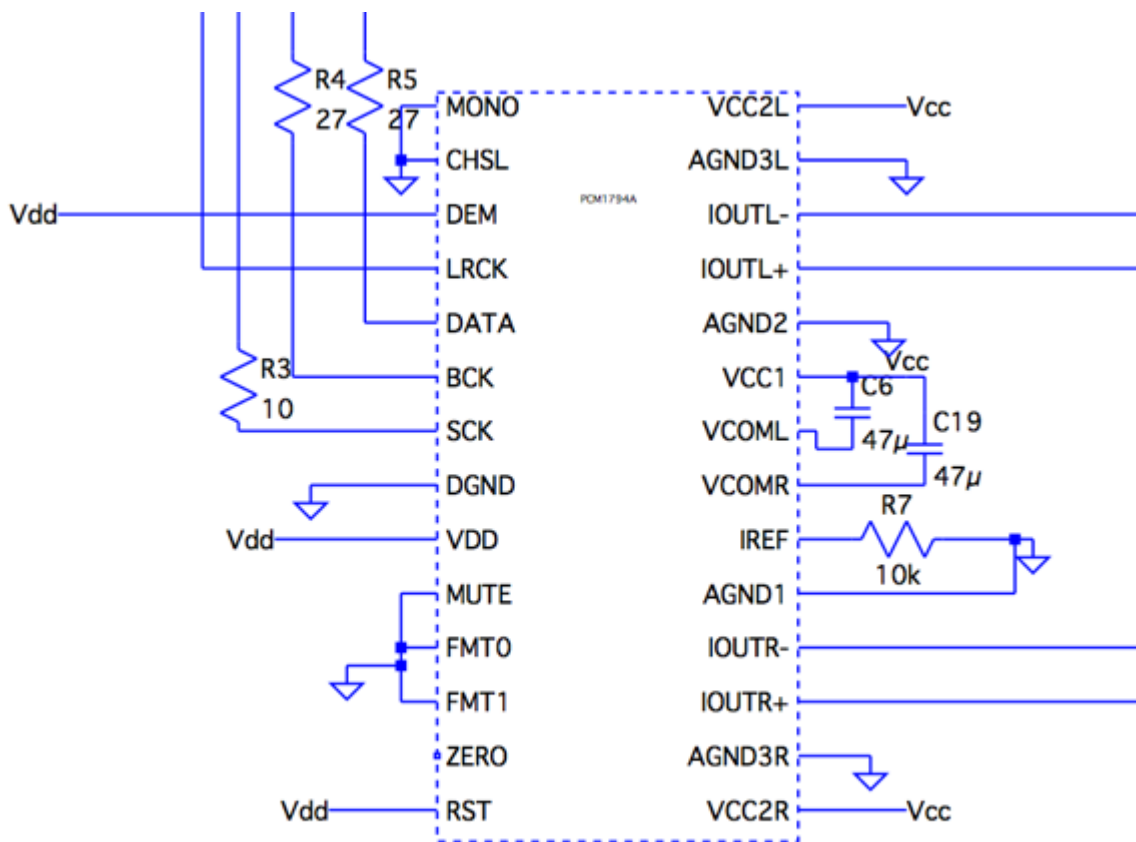

Figure 12: PCM1794A Schematic

TRANSIMPEDANCE DEVICE	
MODULE	Transimpedance device
INPUT	Analog Current
OUTPUT	Analog Voltage
DESCRIPTION	The transimpedance device contains a resistor to ground. This produces a voltage to the Class D Amplifier
REASONING AND IMPLEMENTATION NOTES	-To minimize the complexity, distortion, and power loss, skip a line driver or transimpedance amplifier to favor a passive resistor to ground. Because the Class D amplifier has such a large input impedance, loading issues do not cause a problem

Table 10: Transimpedance Device Module Description

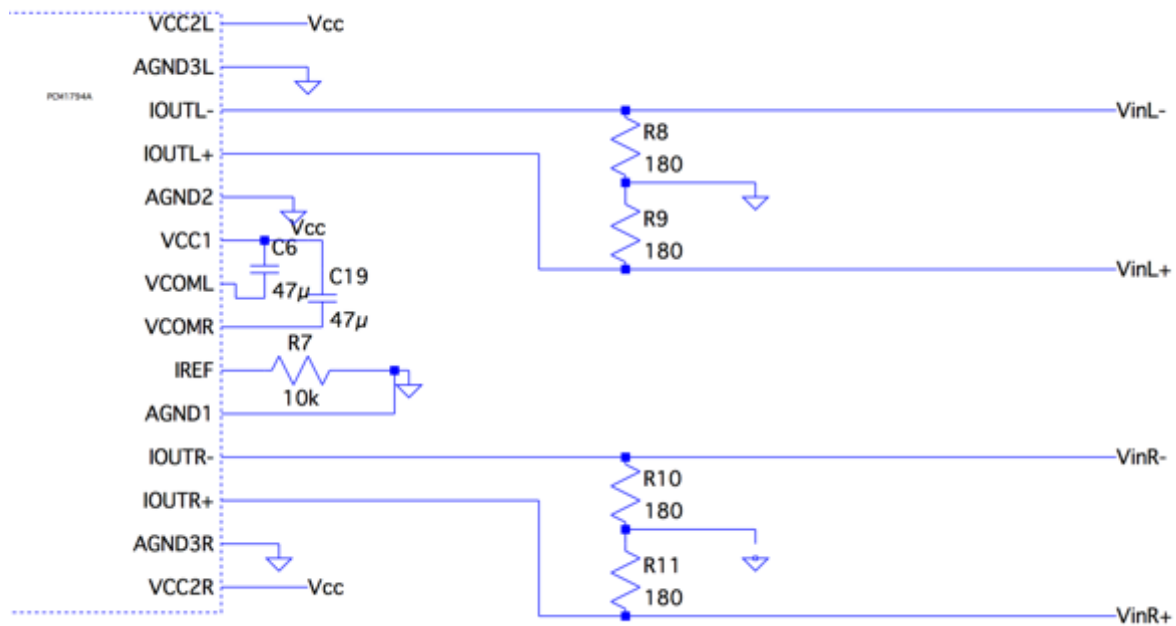

Figure 13: Transimpedance Device Schematic

TPA2008D2	
MODULE	Class D Amplifier
INPUT	Analog Voltage
OUTPUT	Analog Voltage
DESCRIPTION	3-W Stereo Class-D audio power amplifier with DC volume control.
REASONING AND IMPLEMENTATION NOTES	<p>-This amplifier is the only low power stereo audio Class-D amplifier on the market that has leads on the package. Numerous amplifiers exist with higher efficiency and lower distortion and noise specifications; however, the lower powered amplifiers mostly all come with no leads. No experience hinders the and soldering of QFN or DFN. As a person doing a personal project, I prefer to solder with leads on the package such as this TSSOP package.</p> <p>-Choose class D amplifiers in mobile applications because of the high efficiency compared to the Class A or AB counterparts [10].</p>

Table 11: TPA2008D2 Module Description

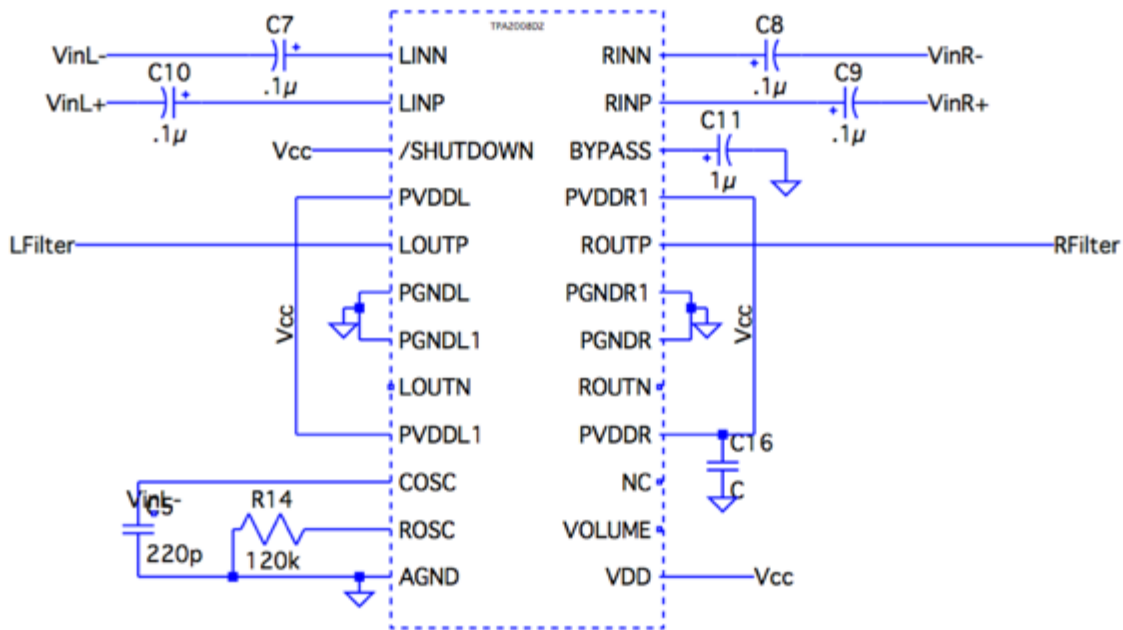

Figure 14: TPA2008D2 Schematic

PASSIVE LC FILTER	
MODULE	Low Pass Filter
INPUT	Analog Differential Voltage
OUTPUT	Filtered Analog Single Ended Voltage
DESCRIPTION	Filters the switching noise from the Class D switching mechanism, and converts 2 differential voltages to 2 single ended voltages for use with headphones.
REASONING AND IMPLEMENTATION NOTES	<p>-The datasheet for the TPA2008D2 says no output filter required if the leads to the speakers are less than 1 inch long. This system expects long leads, so the high frequency switching should not exist before it reaches the cables to the headphones.</p> <p>-The filter filters out ripple current, improving the efficiency and chance that high frequency components get transmitted to the speakers.</p>

Table 12: LC Filter Module Description

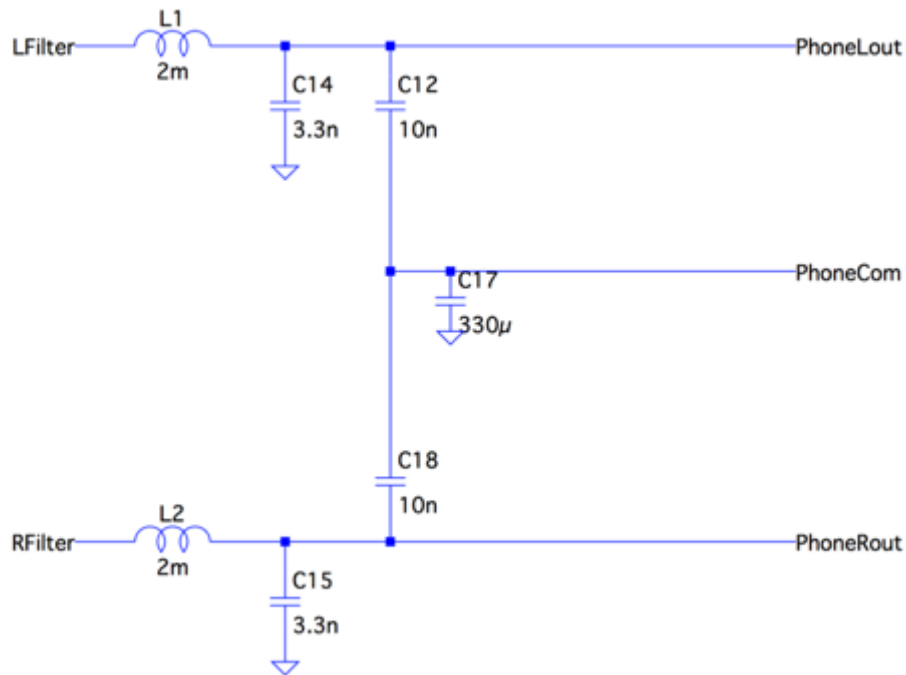

Figure 15: LC Filter Schematic

Battery Management

BQ24092	
MODULE	Battery Charger
INPUT	5 V from V _{BUS} of charging USB port
OUTPUT	3.7 V Li-ion Battery Charging
DESCRIPTION	The BQ24092 takes a 5 V voltage, and provides a controlled charging signal for a 3.7 V lithium ion battery.
REASONING AND IMPLEMENTATION NOTES	Use one micro-USB port solely for the charging the device. A standard USB charger solely provides power for this system. The battery management chip manages the 5 V, bucks it, and controls the current into the battery at 3.7 V and 100 mA. The BQ24092 also provides an option for a thermistor for an extra layer of safety. If the battery reaches a certain temperature while charging, the battery charger shuts off. This allows the battery to cool to a safe temperature.

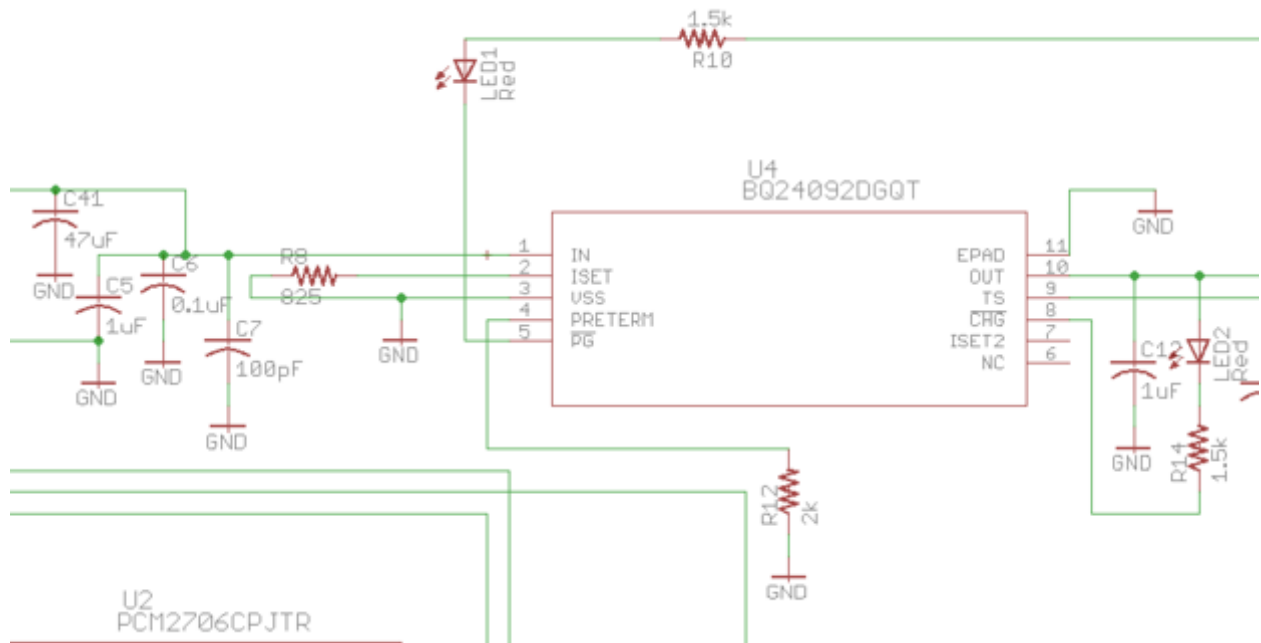

Figure 16: Battery management schematic

Power

LM3671	
MODULE	3.3 V Bucking DC-DC Converter
INPUT	3.7 V DC from Battery
OUTPUT	3.3 V DC
DESCRIPTION	The LM3671 step-down DC-DC converter powers low voltage circuits from a single lithium ion cell battery and input voltage rails from 2.7 V to 5.5 V.
REASONING AND IMPLEMENTATION NOTES	This project needs a low power, small, and efficient voltage regulator for the digital power sources. This device fits all the necessary considerations for implementation into the project. The 3.3V power supplies the digital section of the project.

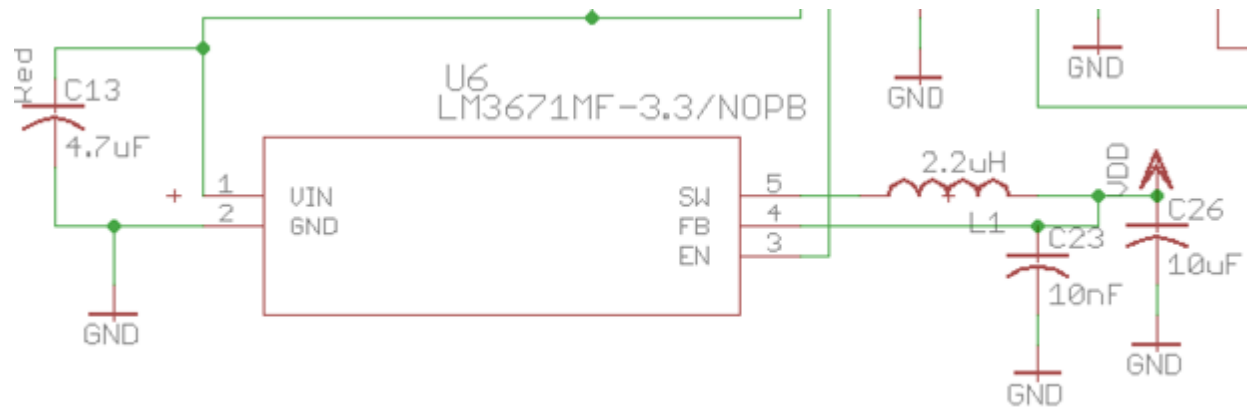

Figure 17: 3.3 V Bucking Regulator Schematic

TPS61222	
MODULE	5V Boost DC-DC Converter
INPUT	3.7V DC from Battery
OUTPUT	5 V DC
DESCRIPTION	The TPS61222 boosting DC-DC converter provides 5 V DC from a lower DC Voltage.
REASONING AND IMPLEMENTATION NOTES	This project needs a low power, small, and efficient voltage regulator for the analog power sources. This device fits all the necessary considerations for implementation into the project. The 5V power supplies the analog section of the project.

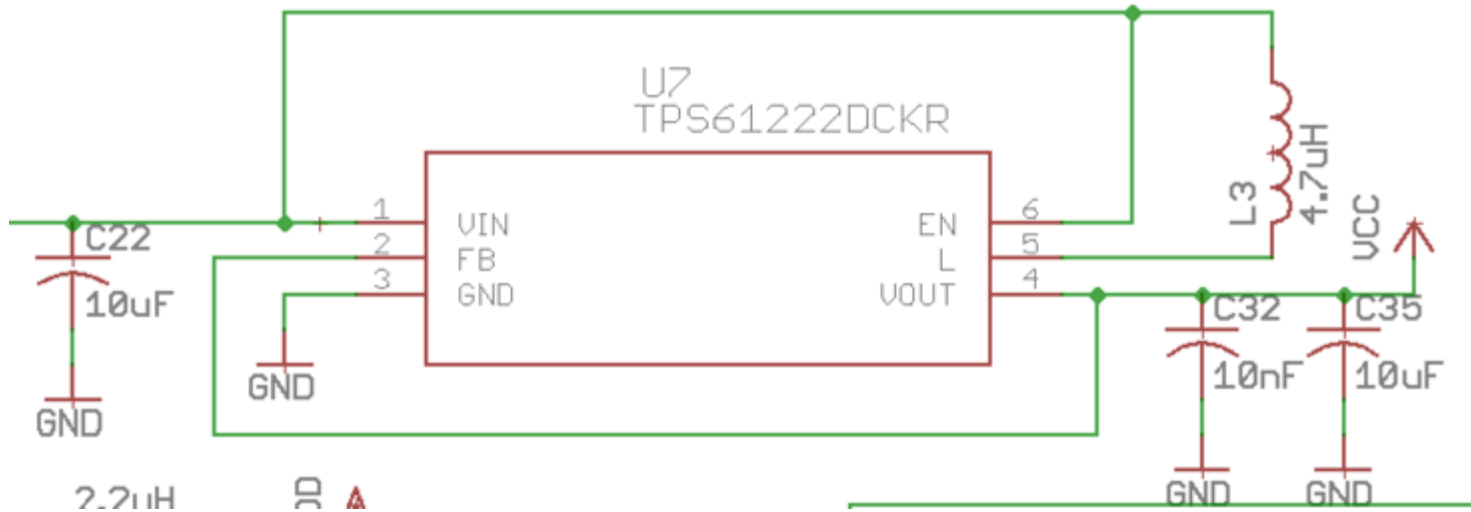

Figure 18: 5 V Boosting Regulator Schematic

Chapter 6 Construction

This Chapter discusses the final construction of the device.

Layout and Printed Circuit Board

Eagle generated a schematic and layout. Because of the high-fidelity audio nature of this product, the board needs careful attention to ground and power planes. Therefore, the board contains separation between analog ground planes, digital ground planes, and switching regulator ground planes. Each IC's datasheet contains recommended board layout with the necessary information on where bypass capacitors should go, and interfacing between planes.

Top Layer

The left side of the top layer contain top ground pours, and the right side contains a mixture of voltage rail pours and ground pours. All the components lie on the top layer.

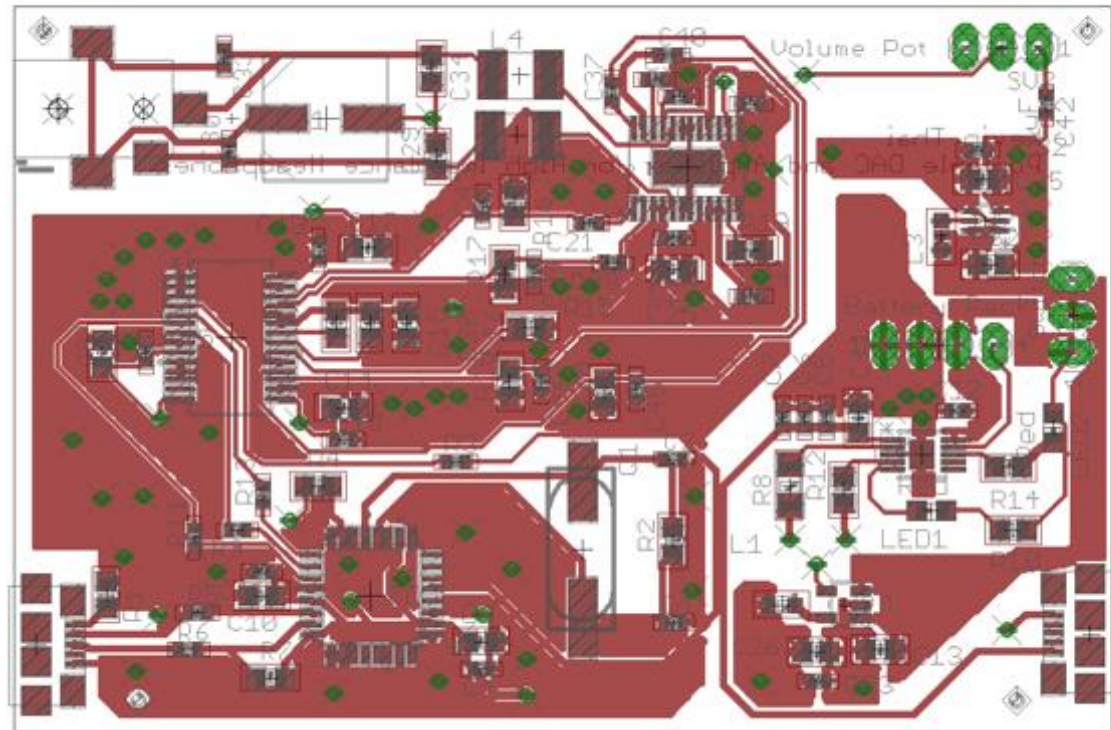

Figure 19: Top Layer PCB Layout

Bottom Layer

The bottom layer contains only ground pours, and a few signal traces. The top left of the bottom layer contains the analog ground, the bottom left contains the digital ground, and the right contains the switching regulator ground plane.



Figure 20: Bottom Layer PCB Layout

Unpopulated Board

OSH Park received the .brd file generated by Eagle. OSH Park charges \$5 for each square inch for a two-layer board. OSH Park charges \$30 for three 2" x 3" boards such as my own. However, time requirements necessitated the need for an expedited process. This doubled the price.

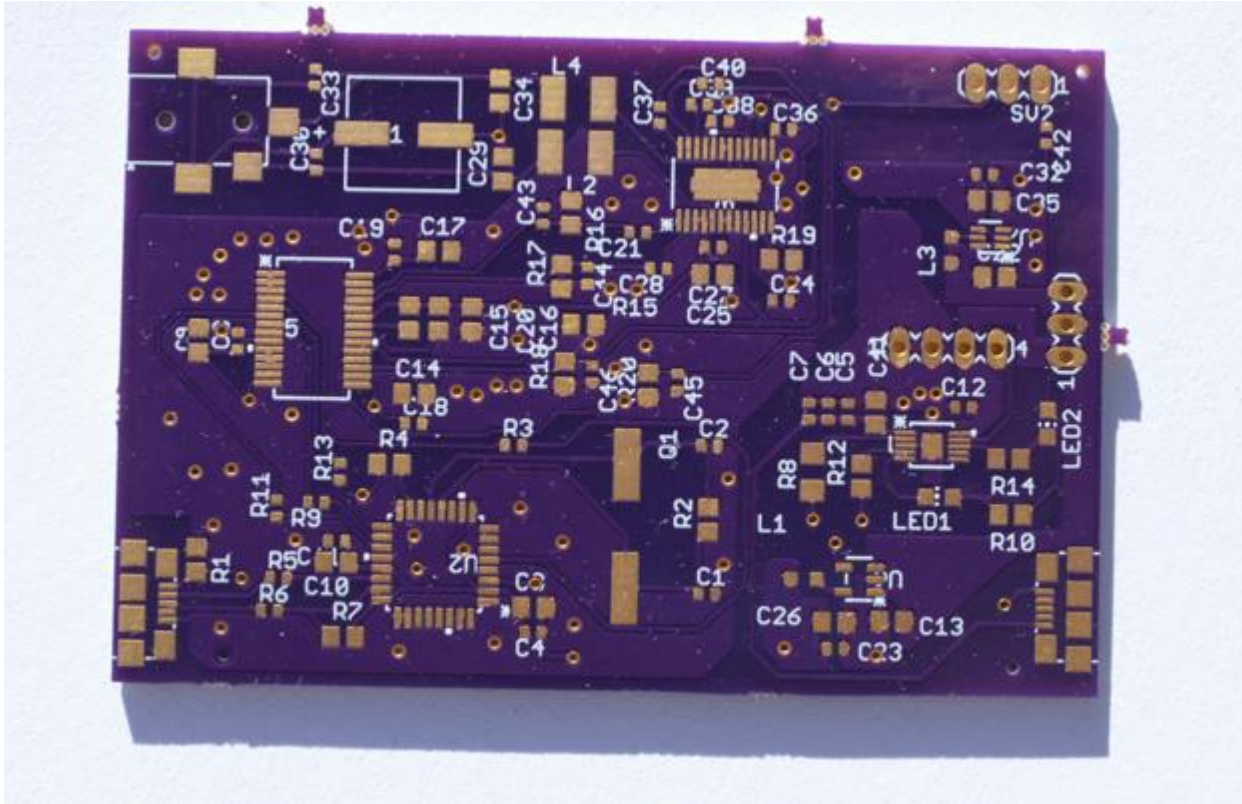

Figure 21: Unpopulated Board

Fully Populated Board with Battery

Through days of hand soldering, all components populated the board. To make the product as flat as possible, 90 degree pins connect the battery to the board. This avoids a permanent connection between the battery and board. This provides an extra level of safety in case the battery fails and requires quick disconnection.

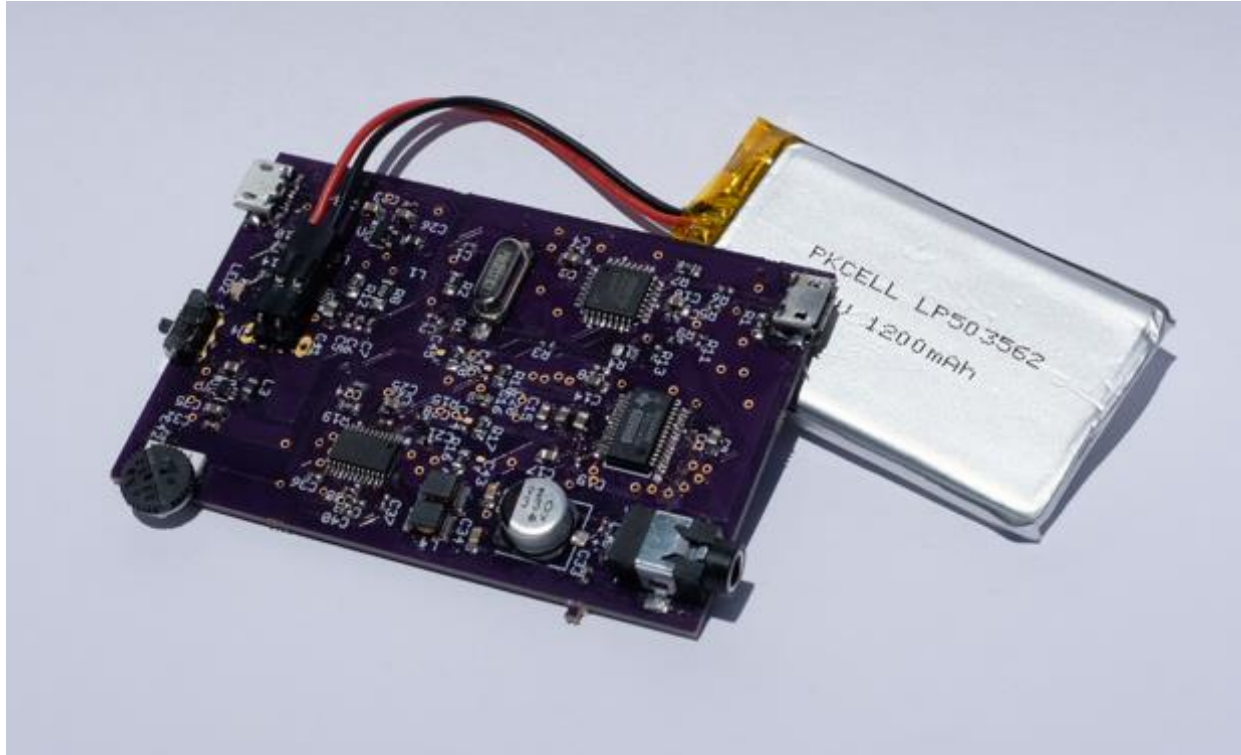

Figure 22: Final Product with Battery

Enclosure (Planned, but never achieved)

Note: An enclosure could not be achieved because the deadline for the project expo came too close to when the board arrived. The drawings and planning for the enclosure occurred months before the fabrication of the final board. For this reason, a difference between the final board and planned enclosure exists.

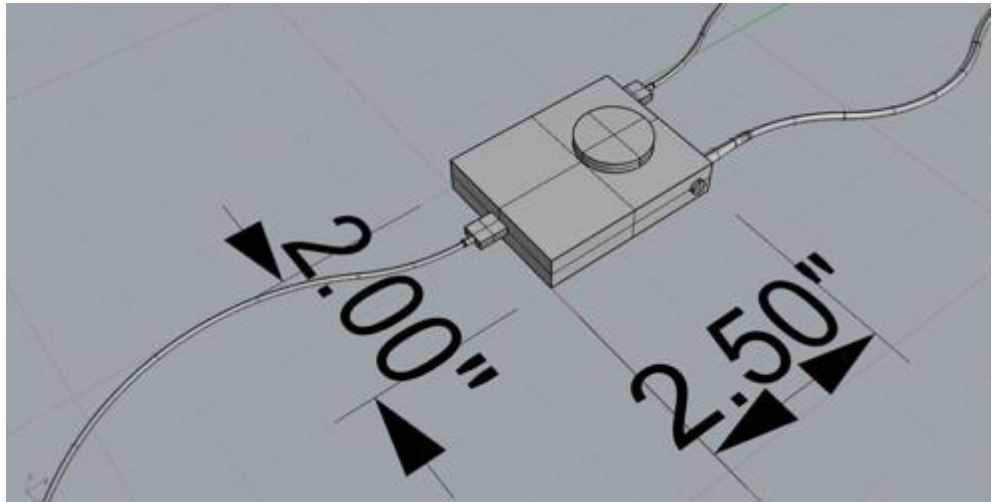

Figure 23: Full Enclosure Isometric Model Measurements 1

A Monoprice Maker Select Plus with PLA (Polylactic Acid) will 3D print the device. The enclosure has two USB ports. The data USB lies on the side with the auxiliary cable. The lone

USB port on the other side takes a USB cable to charge the battery.

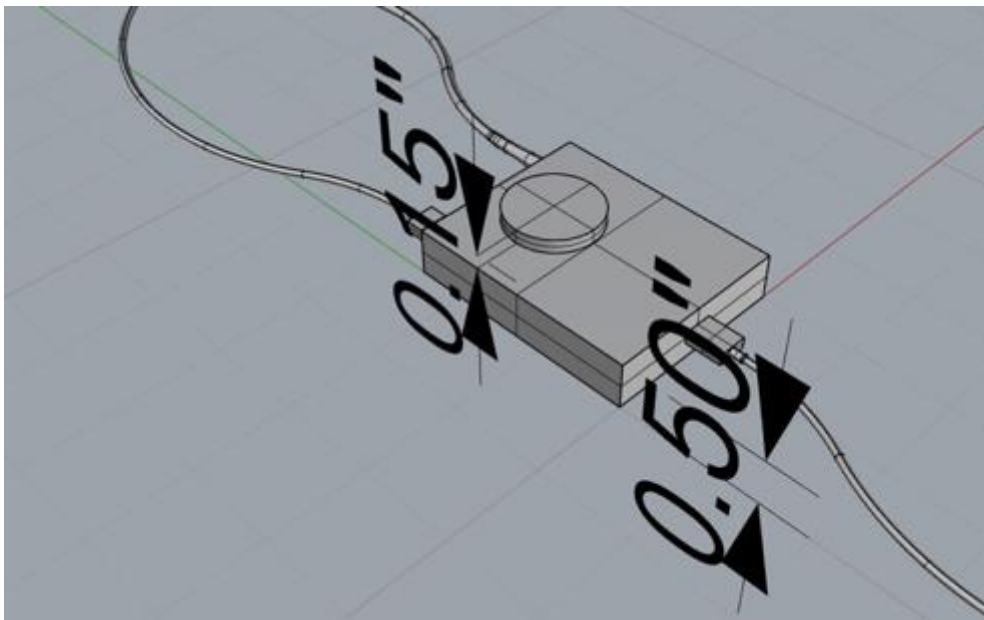

Figure 24: Full Enclosure Isometric Model Measurements 2

The enclosure estimates to 2.50 X 2.00 X 0.50 inches (6.35 X 5.08 X 1.27 cm). A potentiometer increases or decreases a DC voltage that controls the gain of the Class D Amplifier. Lastly, the power switch allows the system to turn off or on.

Chapter 7 Testing

This chapter discusses the system testing.

Breadboard Testing

A breadboard contains the essential parts of the signal path. This breadboard takes 3.3 V and 5V from a power supply, USB communication from a stripped USB cable, and outputs music through a 3.5 mm headphone jack. The breadboard only uses the most essential components. Bypass capacitors do not sit very close to chips, and some don't make it onto the board.

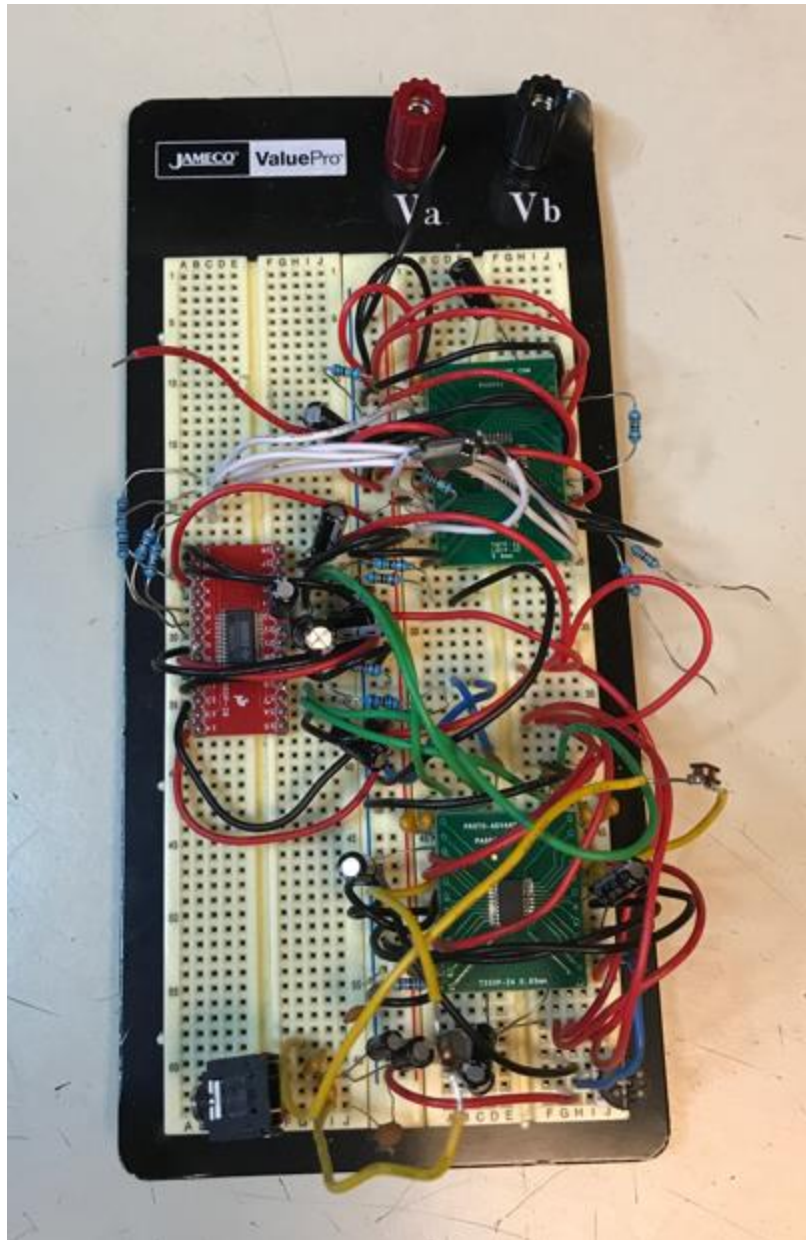

Figure 25: Breadboard with Crucial Signal Path

No Filter Output

Not surprisingly, the Class D amplifier outputs a varying square wave depending on the input. With no input (0V), Figure 26 shows the output. A low pass filter should filter out this switching.

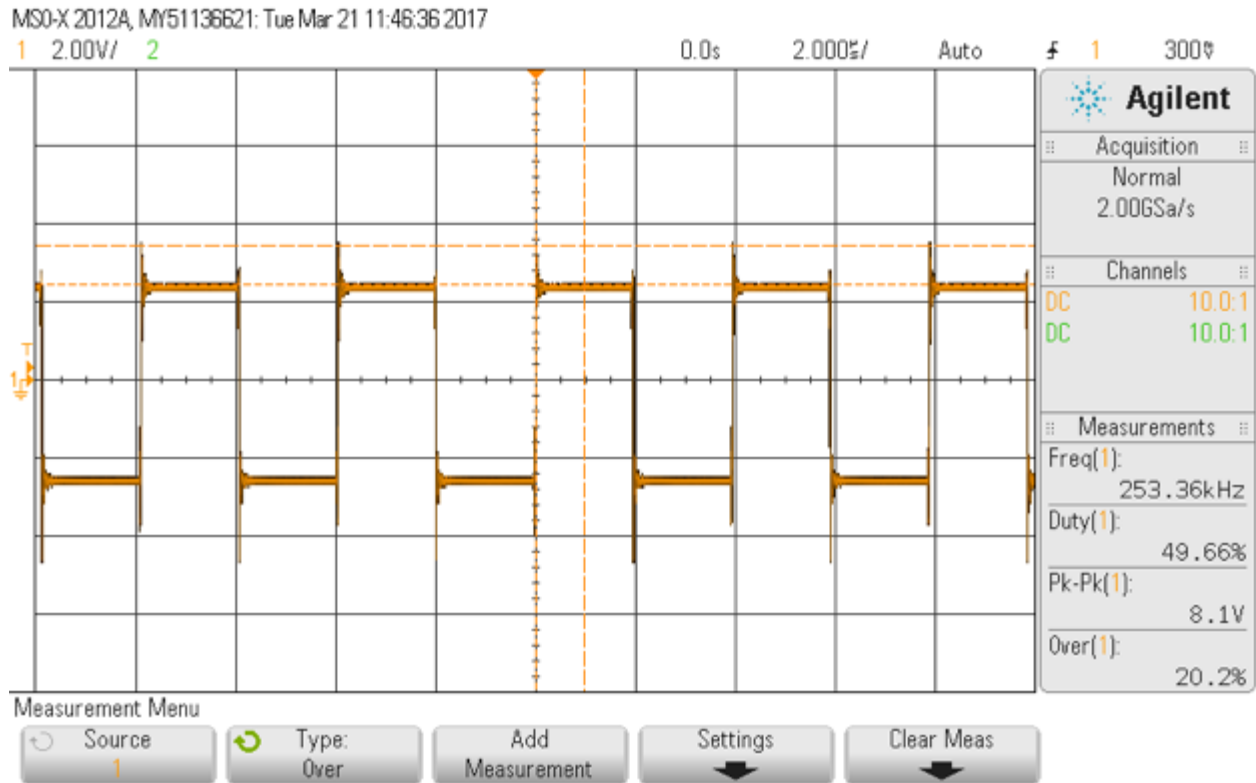
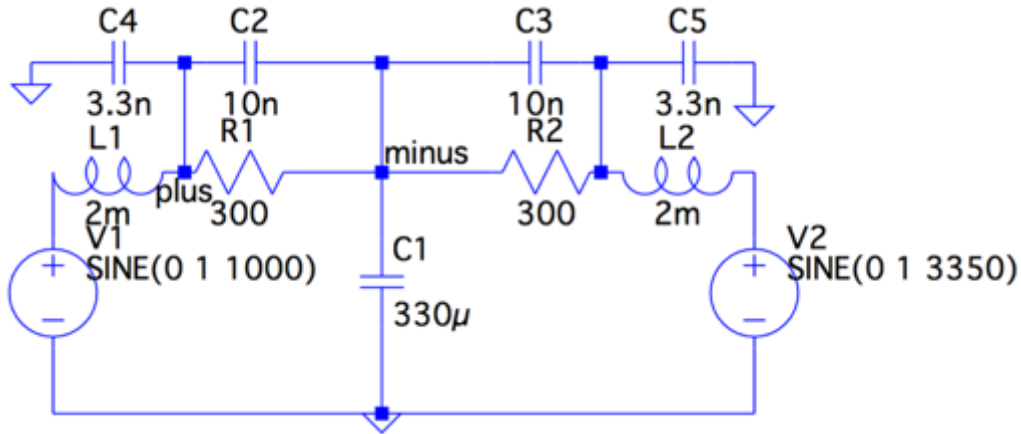

Figure 26: Class D Output with 0 V Input

LC Filter

To design this filter for high impedance headphones, assume a 300-ohm load. Following Texas Instruments' recommended passive LC filter output [11], create a low pass filter with a flat frequency response from 20 Hz to 20 kHz. Note that this amplifier is designed for high impedances, not low impedance loads.



`.ac dec 100 10 50k`

Figure 27: Low Pass Filter Model Schematic

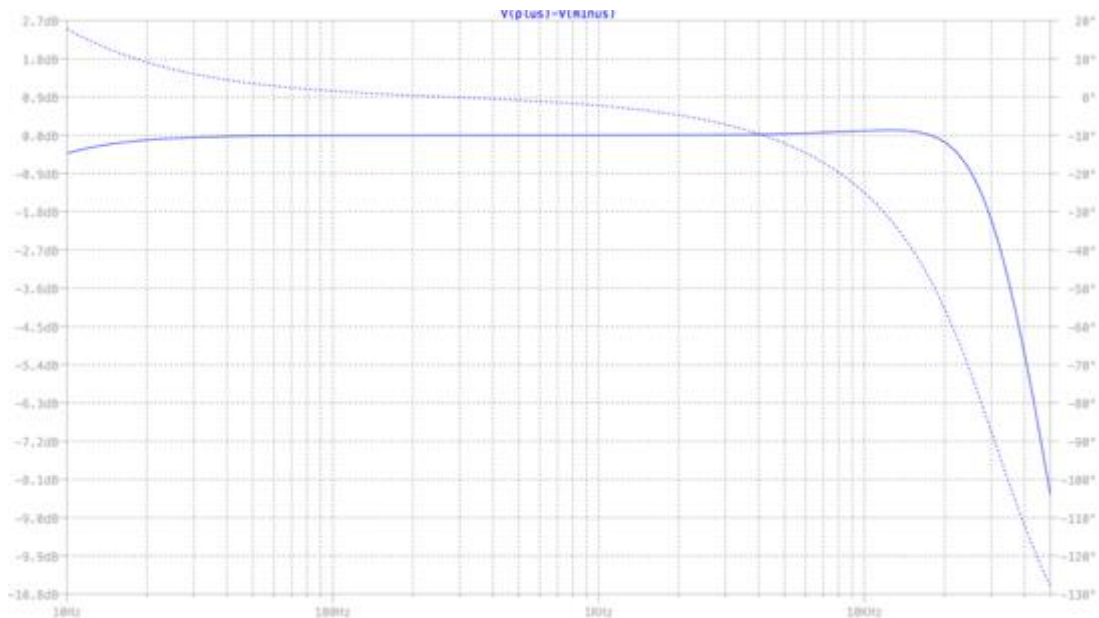

Figure 28: Output Filter Frequency Response

Final System Measurements

Power Consumption

The product draws 60 mA from the 3.7 V battery. The 1200 mA-hr battery, ideally, should last 20 hours on full operation.

Total Harmonic Distortion

Using a 1kHz tone outputted from a computer's USB port, Figure 29 shows the entire audio spectrum outputted from the device THD = 0.019%, while THD+N = 0.052%.

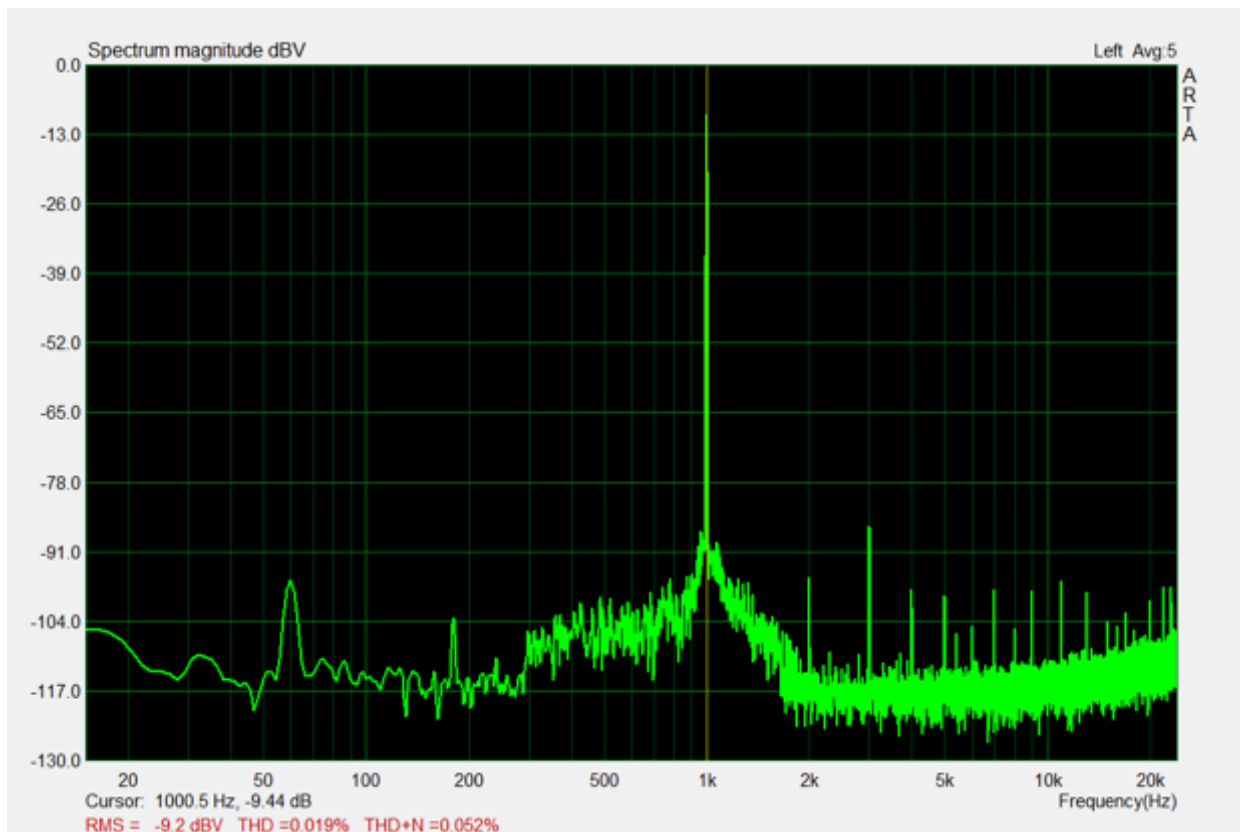

Figure 29: Total Harmonic Distortion Measurement

White Noise Response

To measure the frequency response of the entire audio range, use a white noise input. The -3dB cutoff frequencies sit below 20 Hz and above 20 kHz, meaning the amplifier covers the entire range of audio. The entire audio spectrum looks flat. This produces an accurate frequency response for high-fidelity listening.

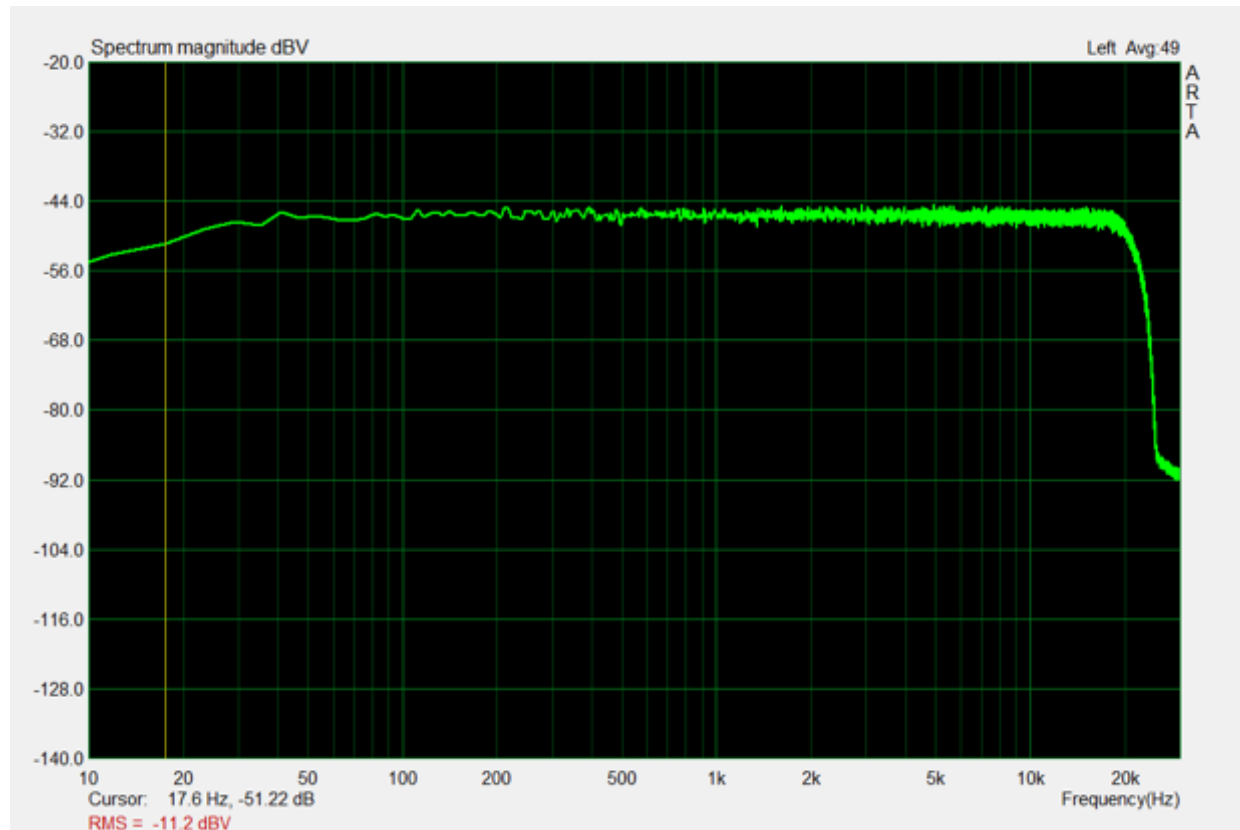

Figure 30: White Noise Input Response

Chapter 8 Operation

To operate this product, simply plug a micro USB cable to the micro USB port on the side of the headphone jack. The other end of the USB cable plugs into a computer or phone. The switch on the other side of the device flips between on and off. Lastly, plug in a 3.5mm headphone connector to the 3.5mm headphone jack.

To operate on an iPhone, use a “Lightning to USB Camera Adapter”.

To operate on an Android device, use a “USB OTG” cable.

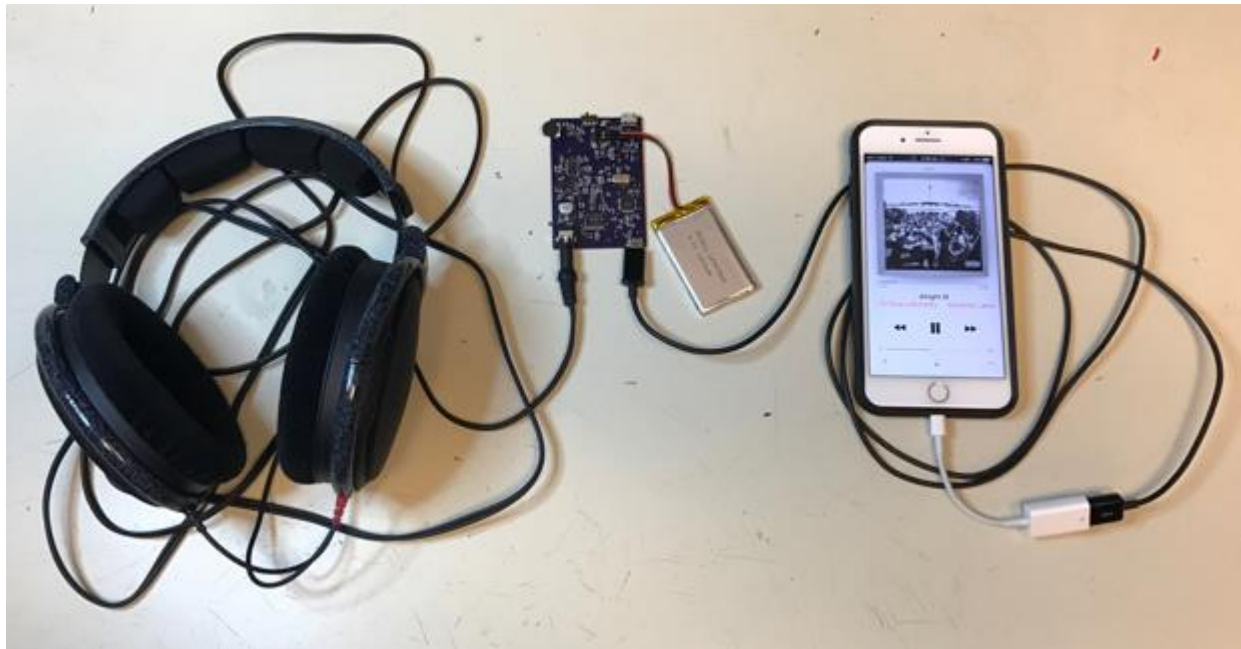

Figure 31: Typical connection

Chapter 9 Conclusions and Recommendations

Conclusions

The project turned out fantastically. After many arduous months, the project finally came together, and works with less noise and distortion than expected. Many audiophiles, and casual listener tried the product. No one has any gripes with the system. The quality of sound reproduction from the DAC, amp, and headphones blows away even audiophiles. The official THD and white noise testing further supports the quality.

Designing this product has gave a different experience from anything that I have done as an engineering student. This design entirely from scratch, with little documentation online on high quality portable DACs and amplifiers for headphones. Through the blood, sweat, and tears, came a product that I am proud that I have built by myself and have in my audio collection.

Future Improvements

- First, design an enclosure for use in portable situations such as walking around. Right now, the board and battery open to anyone, so one should not touch it while in operation.
- Next, reduce the board size. I purposely left empty board space for ease of soldering and testing. However, now I know that the design works flawlessly, layout with less spacing between each component improves the portability of the product.
- The board contains leaded solder; however, use unleaded solder for better health and safety design and usage.
- The digital source cannot currently control the output volume cannot. This makes operation confusing for some customers because they may try to change the volume through their phone, or computer and nothing happens. Implement an easier to use volume controller.
- Currently, the only turning off the device mutes the volume. Implement a mute button, or at least volume control that shuts off the sound.

Recommendations for Amateur Designers

- For a student engineer, without access to high quality equipment to place packages with no leads, I recommend buying packages for IC's that do contain leads. Without leads, only a stencil and reflow oven can solder the package to a board consistently. Currently, Cal Poly's EE department does not have these tools easily accessible.
- When building a schematic for the design, pay attention to the inputs and outputs. Do not try to input anything if the datasheet clearly marks it as an output. This saves much time and money when the IC's do not blow up.
- Testing analog circuits with breadboards may bring in unwanted noise and losses that PCBs avoid. Therefore, a designer cannot always trust any testing from a breadboard. PCBs give the best results in terms of noise.
- Use the datasheet's recommended PCB layout guide. Without proper PCB layout, the product may attract more noise, and unnecessary losses. Certain IC's may not work properly without proper PCB layout.

Chapter 10 Appendix A: Analysis of Senior Project Design

Project Title: Portable DAC and Amplifier for High Impedance Headphones

Student Name: Kevin Thai

Advisor Name: David Braun

1. Summary of functional requirements

The product makes an audiophile's system portable. It takes the USB data from a phone or laptop, converts it to analog through a high-fidelity DAC, and amplifies the analog signal for load impedances of 300 ohms. The system runs off a 3.7 V 1200 mA-Hr battery, and lasts on batteries for 20 hours.

2. Primary Constraints

Implementation in a small, lightweight and portable fashion primarily constrains student designers. Working with chips too small for a small-scale production can produce challenges. Without proper training and equipment, an amateur may find DFN and QFN chips difficult to work with. Therefore, package characteristics and solderability eliminate DFN and QFN chips from consideration. Because the low power chips necessary for this portable application tend to be very small, only a select few have leads. The chip choices diminish.

Next, a battery size must last a decent amount of time, but also small enough to comfortably fit inside of a pocket with a phone. Therefore, I chose a 3.7 V, 1200 mA-Hr, lithium ion battery for maximum play time in a small package.

The plethora of audio parts cost too much for a small and underfunded operation. Therefore, evaluation on cost benefits requires more thought.

PCB layout requires experience and knowledge that a beginner must acquire. Each chip must have special care, and different ground and power planes must have special attention. Initially, the breadboard provided essential signal path testing. However, electrical engineers do not actually test like this. Order PCB's, test them, and order multiple revisions of PCBs if the original layout does not work. Breadboards provide too much noise for an analog device. However, Cal Poly only provides 20 weeks for full design of the project, so breadboards give a quick and feasible solution to a time crunch.

3. Economic

The device has significant impact on human, financial, and natural capital. Manufacturing of the device uses machines such as soldering irons, microscopes, electrical testing equipment and others developed and bought from other companies. In addition to this, every component used inside the device borrows from other companies, further establishing that this product connects financially to many suppliers. Therefore, financial capital increases because of the flow of money from one developer to another.

Next, human capital increases dramatically because of this product. This product uses many components from other companies. The developers, designers, manufacturers, etc. of the companies that the product buys from all experience affects from the design process, manufacturing, and use of this product. Any improvements on the product should require more helping hands in the design processes. The project requires more engineers and manufacturers to ease the design process and further increase the human capital generated by the product.

Natural capital further increases because of this product's use of metals, plastics, and semiconductors. This contains a battery. Creating, and disposing of a battery immediately has effects on natural capital. We encourage proper disposal of electronic waste for a sustainable future.

The direct costs may vary from \$50-\$70 depending on how many chips/resistors/capacitors one buys at one time. Massive orders of thousands of components drop the price of components, and PCBs significantly. However, since mass production plans currently do not exist, the next page contains costs in the form of a bill of materials.

The timing of this product is almost perfect with the release of phones that do not have headphone jacks. This product may sell much better because customers might want a digital to analog converter for their phones that no longer contain a DAC.

Build of Materials					
Part	Quantity	Manufacturer 1	Part #	Price	Part Total
DAC	1	Texas Instruments	PCM1794A	13.78	13.78
Amp	1	Texas Instruments	TPA2008D2	4.39	4.39
Battery Management	1	Texas Instruments	BQ24092DGQR	1.22	1.22
3.5 mm Audio Jack	1	CUI Inc.	SJ2-35943A-SMT-TR	1.44	1.44
Micro USB port	2	Amphenol FCI	10118192-0001LF	0.46	0.92
Resistors	20	Yageo	-	0.1	2
330 uF Capacitor (Aluminum)	1	Nichicon	UWX0J331MCL1GB	0.231	0.231
Capacitors (Ceramic)	45	Yageo	-	0.1	4.5
Inductor 2.2mH	2	Murata Electronics	LQH43NN222K03L	0.66	1.32
Inductor 0805	2	TDK	-	0.14	0.28
3.7 V 1200 mA-Hr Lithium Ion Battery	1	Sparkfun	LP503562	13.18	13.18
USB Audio to I2S Converter	1	Texas Instruments	PCM2706C	7.41	7.41
10K THERMISTOR	1	Cantherm	MF52C1103F3380	1.86	1.86
3.3 V Buck Regulator	1	Texas Instruments	LM3671MF-3.3/NOPB	0.92	0.92
5 V Boost Regulator	1	Texas Instruments	TPS61222DCKR	1.16	1.16
POT 1.0M OHM	1	Bourns Inc.	3352T-1-105LF	1.53	1.53
Red LED	2	OSRAM Opto Semiconductors Inc.	LS R976-NR-1	0.26	0.52
Switch	1	C&K	JS202011SCQN	0.46	0.46
2"x3" two-layer board	1	OSH Park	-	10	10
12 MHz Crystal Oscillator	1	ECS Inc.	ECS-120-18-5PX-JEM-TR	0.33	0.33
				TOTAL	67.451

Table 13: Bill of Materials

4. If manufactured on a commercial basis

This specialized product aims to sell a small group of audiophiles who would like to take their headphones out into public. Therefore, estimate 20-30 devices sold a year: this comes from various clubs such as Cal Poly's AES (Audio Engineering Society), or audiophile friends.

According to the Estimated Costs of Manufacturing section in Chapter 4, the estimated cost for manufacturing equals \$92.50. This accounts for the BOM, and an estimated cost for PCB and 3D printed housing. Therefore, the product's cost to a customer predicts \$200. This yields a profit of \$107.50 for each device. Therefore, if the optimistic 30 devices sell, then the product gives a profit of \$3225.

For an average person to run this device, they must charge the battery. If someone charges the 1200 mA-hr battery once every other day for 365 days, then the total energy used estimates to $3.7 \text{ V} * 600 \text{ mA-hr} * 365 \text{ days} = 810 \text{ W-Hr}$. The average American pays \$0.12 per kW-hr [12]. Therefore, it costs \$0.10 to use this device for an entire year.

5. Environmental

The testing and manufacturing process requires many energy resources such as fossil fuels and nuclear energy. Also, the design of this project uses many plastics, silicon, and other metals. The addition of a lithium ion battery greatly increases the impact on the environment because of the extra pollutants that the manufacturing of batteries creates.

In addition to the obvious environmental impacts that the direct parts have, the unobvious impacts still need accounting. Multiple shipments of parts from across the globe consume many fossil fuels from shipping trucks, airplanes, and cargo ships. The countless hours of electrical test equipment used for this project also adds to the energy consumed in the design of this project.

Lastly, the use of this product slowly takes energy from whichever energy sources the USB charger comes from. However, using the product instead of a desktop DAC and headphone amplifier greatly reduces energy that non-portable devices normally draw.

6. Manufacturability

Manufacturing challenges occur with this product when someone manufactures the product without the necessary equipment for soldering small surface mount components. An official PCB manufacturer must manufacture the boards. Each board costs more if ordering few boards at a time.

However, if done by a developed manufacturer in a laboratory with specialist technicians, the question of manufacturability comes to naught. All components should already come presoldered on the PCB, so no extra set up required for the customer. Sending this to customers may cost very little through a postal service because of the size.

7. Sustainability

The device operates off a small 1200 mA-Hr battery. The total product life of the battery judges how sustainable the project may be. Recharging the battery requires very little energy, and the

operation of the device may save energy used because the product may replace certain desktop DAC's and headphone amplifiers that draw much more energy than this portable device.

Regarding the product life, it should last a few years, or until the lithium ion battery no longer has a useful lifespan. Electronic audio products tend to last a long time. The battery probably needs to be replaced every few years.

8. Ethical

Follow the IEEE Code of Ethics for the project:

1. Follow necessary precautions to reduce customer's risk of harm. Volume control limits volumes as to not deafen a listener. Implement a thermistor for the battery charger to help reduce the risk of the battery exploding or heating too much.
2. Account for the entire design process, shortcomings, and work arounds that made this product work.
3. Make all claims and estimations honest. No fake results exist in this report.
4. No bribes offered, but accept no bribes if offered.
5. The project report informs people of the techniques of developing audio equipment, why the necessity for some audio equipment, and aims to teach people of the wonders of high fidelity audio.
6. The device needs a technical competence to produce and maintain this device.
7. Give peers and audiophiles equal opportunities to critique and give honest opinions on the technical work provided in the report.
8. Treat no person unfairly with this project. Everyone has an equal opportunity to develop and shine in their own ways.
9. Use proper precaution to avoid injuring other people.
10. Give assistance to colleagues and co-workers to support them following these codes.

Utilitarianism

This product aims to produce high fidelity music to maximize effectiveness of a user's expensive high impedance headphones. To sell this product, the price would be much higher than a normal consumer would ever spend on any audio equipment. However, the product does not aim to sell to the masses. Because audiophiles represent a small portion of the population, one must ignore typical consumers when dealing with costs. Audiophiles buy very expensive equipment, and want the best out of whatever they buy. Therefore, a full potential listening experience outweighs the cost of the device.

9. Health and Safety

All products chosen with ROHS compliance, and the PCB manufactured without lead free traces. The volume control limits to a certain volume to not deafen a listener. A thermocouple connects to the battery charger. If the battery gets too hot while charging, then the battery charger shuts down.

However, more time to work on the product improves health and safety. First, use unleaded solder to further lessen the amount health issues dealt with heavy metal poisoning. Lastly, build an enclosure so anyone would not be able to touch the device. Right now, a user may only touch the sides of the board because of the risk of electric shock and ruining the board.

10. Social and Political

The product's design process has the possibility of social and political implications. The design and manufacturing of this product might bring up social and political issues because of where the companies manufacture the parts. Companies manufacture many individual products of this project in other countries. Manufacturing in other countries may have different social and political implications that choosing products from the USA avoid. However, designers may find it hard to overcome these issues because of the costs and availability of ICs and devices fully made in the USA.

To avoid more social and political backlash from designing this product, I used OSH Park to develop the PCB for the project. Peers suggest many other PCB fabrication services, but OSH Park makes all PCBs in the USA, which has the laws and standards that more closely follow the IEEE code of ethics. Although cheaper, avoid outsourcing PCBs to a different country, they follow different laws and standards to the USA.

The project directly impacts the engineers that helped design the project. Jaime Carmo helped teach how to solder many surface mount components. Vladamir Prodanov helped with the design up some analog components. Richard Murray helped with the developing an idea, and initial report. Lastly, David Braun advised the entire process, and kept the project going even if it looked like it would go nowhere.

11. Development

The project gives an in-depth introduction to Eagle for schematics and board layout. This helps with future designs. This significantly helps in the future when designing more complex boards. For future designs, never breadboards. Fabricate PCBs and test multiple revisions to properly test how a product may act under real conditions. Lastly, putting together the device necessitates the technical skill of soldering small surface mount devices such as IC's with 0.5 mm pitch, or 0402 sized resistors. This allows a designer to choose smaller chip sizes and not worry about working with too small of devices.

Chapter 11 Works Cited

- [1] "What is a DAC?," [Online]. Available: <https://www.headphone.com/pages/what-is-a-dac>. [Accessed 19 March 2017].
- [2] S. Guttenberg, "Headphone buyers: Here's what you need to know about low- vs. high-impedance models," CNET, 12 September 2015. [Online]. Available: <https://www.cnet.com/news/headphone-buyers-heres-what-you-need-to-know-about-low-vs-high-impedance-models/>. [Accessed 19 March 2017].
- [3] r. a. M. Chris J, "Headphone Impedance," 2012 August 2012. [Online]. Available: <http://www.head-fi.org/a/headphone-impedance>. [Accessed 19 March 2017].
- [4] Andy, "Headphone Sensitivity," The Headphones Guide, 29 June 2013. [Online]. Available: <http://www.theheadphonesguide.net/headphone-sensitivity/>. [Accessed 20 March 2017].
- [5] "Sennheiser HD 600 Headphones," Headphone.com, [Online]. Available: <https://www.headphone.com/products/sennheiser-hd-600>. [Accessed 20 March 2017].
- [6] "Occupational noise exposure," OSHA, [Online]. Available: https://www.osha.gov/pls/oshaweb/owadisp.show_document?p_table=standards&p_id=9735. [Accessed 20 March 2017].
- [7] J. Souvanen, "Inside Apple's New Audio Adapter," IFIXIT ORG, 5 October 2016. [Online]. Available: <http://ifixit.org/blog/8448/apple-audio-adapter-teardown/>. [Accessed 19 March 2017].
- [8] F. a. Coulston, "Design for Electrical and Computer Engineers," in *Design for Electrical and Computer Engineers*, New York, McGraw-Hill Education, 2007.
- [9] "WHY I2S," North Star Design, [Online]. Available: http://www.northstar-audio.co.uk/why_i2s.html. [Accessed 20 March 2017].
- [10] D. Mellor, "What is Class-D Amplification?," Sound on Sound, June 2006. [Online]. Available: <http://www.soundonsound.com/techniques/what-class-d-amplification>. [Accessed 20 March 2017].
- [11] Y. B. Quek, "Class-D LC Filter Design," February 2015. [Online]. Available: <http://www.ti.com/lit/an/sloa119b/sloa119b.pdf>. [Accessed 21 March 2017].
- [12] J. Jiang, "The Price Of Electricity In Your State," Planet Money, 28 October 2011. [Online]. Available: <http://www.npr.org/sections/money/2011/10/27/141766341/the-price-of-electricity-in-your-state>. [Accessed 9 April 2017].
- [13] B. C. C. H. & R. S. Joshua Ho, "The iPhone 6 Review," AnanTech, 30 September 2014. [Online]. Available: <http://www.anandtech.com/show/8554/the-iphone-6-review/11>. [Accessed 19 March 2017].

Chapter 12 Thank You

To my mother, father, and sister. You are the ones who taught me how to love and survive in this crazy world.

To Professors Vladamir Prodanov, Richard Murray, and Clay Mckell. You helped develop ideas in the design process.

To Jaime Carmo. You helped teach me valuable technical skills for the project.

To Kendall Searing. You let me borrow so much of your equipment and time.

To Professor David Braun. You encouraged me to keep going when everything seemed to be lost.

To coffee. You kept me concentrated.

To beer. You kept me distracted when concentrating was too detrimental.

To my friends Zoe Hay, Eric Koch, Kelsey Rodriguez, Jason Rivera, Lincoln Tran, and Wilson Yeh. You helped me through my college career, and are still here after seeing the best and worst of me.

To Joannie Tran. For being everything that I can ask for.