

# Standby Power-Saving Power Strip

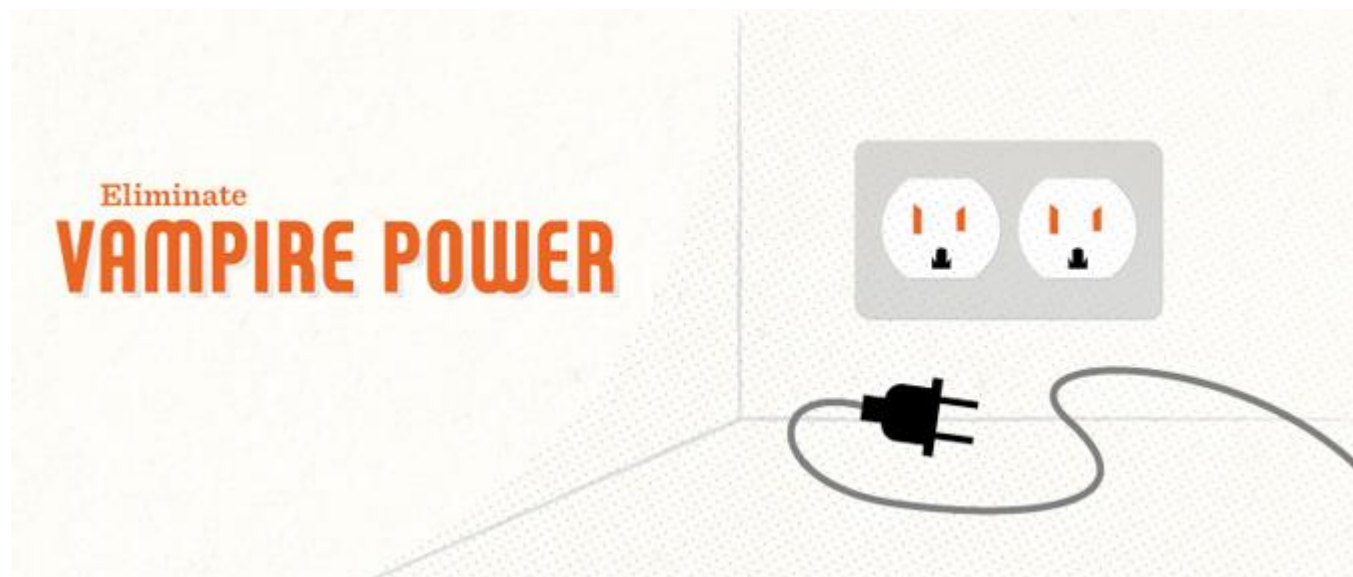

by

Trung Nguyen

Senior Project

California State University, San Luis Obispo

Electrical Engineering Department

June 2017

## **Abstract**

The Standby Power Saving Power Strip improves on common power strip functionality. The project reduces the power loss from most electrical devices' standby power mode, while retaining the convenience of leaving the devices plugged-in. The surge protector automatically recognizes when the plugged-in devices enter standby power mode. Then, it shuts off power to that device and automatically provides power back to the plugged-in devices, when turned on.

# Table of Contents

Abstract .....	ii
Table of Figures and Tables.....	iv
Acknowledgment .....	v
Chapter 1. Introduction .....	1
Chapter 2. Background .....	4
Chapter 3. Requirements and Specifications .....	6
Chapter 4. Design.....	9
Chapter 5. Hardware Test and Results.....	13
PIR Sensor Test.....	13
Solid State Relay Test.....	14
Current Sensor Test.....	16
Complete System Test .....	18
Chapter 6. Conclusion.....	20
References.....	21
Appendix A: Senior Project Analysis .....	23

## Table of Figures & Tables

Figure 1-1. Residential Electricity Consumption by Region, 1990-2006.....	1
Figure 1-2. World Total Primary Energy Supply (TPES) from 1971 to 2014 by Fuel.....	3
Figure 3-1. Level 1 Power Strip Design Functionality .....	7
Figure 4-1. ATMEGA328B Microcontroller Chip .....	10
Figure 4-2. Software Block Diagram of Standby Power Saving Surge Protector .....	10
Figure 4-3. AKM CQ320B Current Sensor Chip .....	11
Figure 4-4. Parallax 555-28027 PIR sensor .....	11
Figure 4-5. Uxcell SSR-25DA Solid State Relay .....	12
Figure 5-1. PIR Sensor Test Bench Setup.....	13
Figure 5-2. Oscilloscope Capture of PIR Sensor Functionality .....	14
Figure 5-3. SSR Test Bench Setup.....	15
Figure 5-4. SSR Functionality Waveform .....	15
Figure 5-5. CQ320-B Functional Block Diagram.....	16
Figure 5-6. Current Sensor Test Bench Setup.....	17
Figure 5-7. Complete System Test Bench Setup .....	19
Figure 5-8. Complete System Test Bench Setup .....	19
Figure A-1. Project’s Gantt Chart for Winter and Spring 2017 .....	25
Table 1-1. Power Consumption of Electric Appliances.....	4
Table 3-1. Power Strip Functionality Summary .....	8
Table 5-1. Current Sensor Functionality Results .....	17
Table A-1. Estimated Cost.....	24

## **Acknowledgment**

I would like to thank Dr. Taufik for his guidance and teachings, which got me passionate and interested in the field of power electronics. It was from power electronics that helped me create design ideas to implement and construct this project.

I would like to thank the Cal Poly Electrical Engineering Department for access to their resources, faculty, and instruments.

## Chapter 1. Introduction

Global residential electricity consumption is growing as the number of electrical appliances in the average household increases. This is true across all countries in the world as population grows and as indicated in Figure 1.1. For example, between 2001 and 2007 in Mauritius, the number of households with television rose from 85% to 95.9%, with refrigerator from 74.9% to 89.2%, and with washing machine from 39.8% to 61.1% [1].

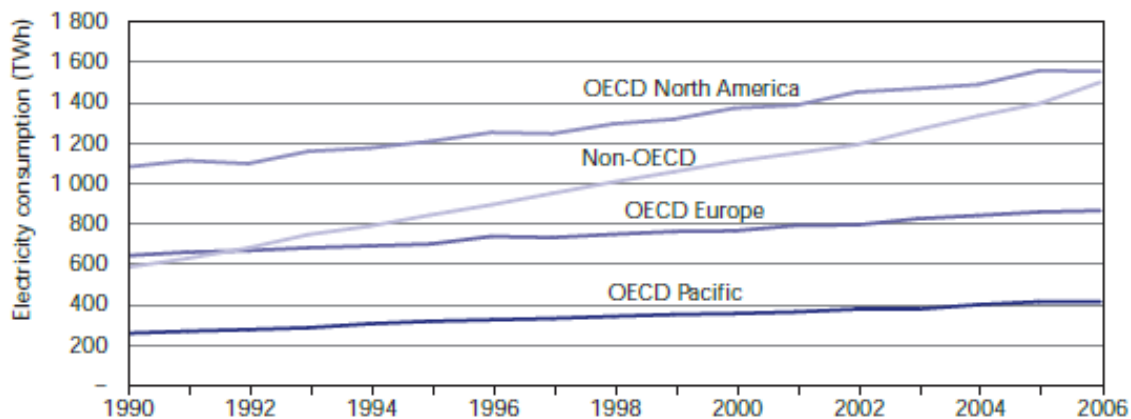

**Figure 1-1. Residential Electricity Consumption by Region, 1990-2006 [1]**

Another cause of the increase in world-wide consumption in electricity can be contributed from the prevalent use of consumer electronics especially portable devices such as cell phones, laptops, and tablets. Their fast growth is mostly due to easier access to internet and their affordability. In 2010, there were over 3.5 billion mobile phones, 2 billion TVs, and 1 billion personal computers in use around the world [2]. Now, there are approximately 20-30 different electrical appliances and electronics in residential homes or units. Technological advancement in engineering has made this possible through creating more efficient, smaller, and faster electronic devices. One technology called Power Electronics as an example has gone a long way in advancing faster switching devices which allow the use of smaller electronic

components such as inductors and transformers while reducing energy loss. This in turn provides the essential key in minimizing the size of portable adapters and elongating battery life [3].

However, the rapid growth in electronic devices is not without its drawback. In particular, they introduce a problem associated with increased residential energy consumption despite its energy efficient operation. Again as shown in Figure 1-1, between the period of 1999 and 2007, the total residential electricity consumption has grown a total of 13%, from 708 TWh to 801 TWh [4]. Out of these, according to the IEA the energy consumption coming from information and communication technologies (ICT) and consumer electronics (CE) accounts for nearly 15% of global residential electricity consumption in the recent decade [2].

The increase in electricity consumptions consequently causes an increase in demand for more energy production. This in turn causes the increase in production of oil, coal, natural gas, nuclear, and other energy supply. As shown in Figure 1-2, worldwide energy supply has more than double from 1971 to 2014. In addition, the figure shows an increasing rate for energy supply from 2005 to 2014, which implies a dramatic demand for fuel resources. This causes harmful and negative impacts to the environment and sustainable resources such as increasing CO<sub>2</sub> emissions, waste byproducts, greenhouse gases, pollutions, and more. The International Energy Agency (IEA) has responded to this problem by several means. One method is by urging countries and governments around the globe to implement policies to produce more energy efficient devices. The IEA researches show that using the best available technology and processes could cut residential electricity consumption by more than half [2]. This energy saving action can reduce consumer energy bills by over USD 130 billion and the avoidance of 260 GW in power generation in 2030 [6].

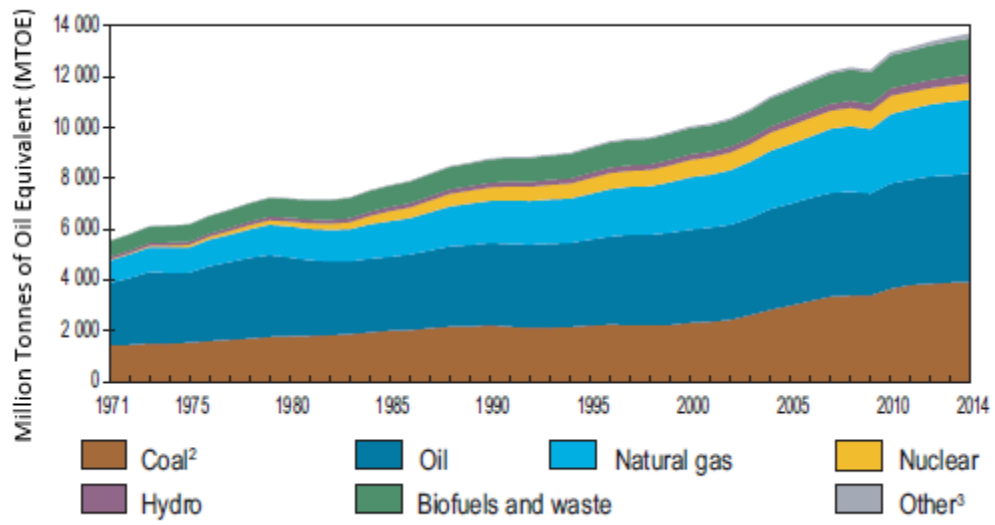

**Figure 1-2. World Total Primary Energy Supply (TPES) from 1971 to 2014 by Fuel [5]**



## Chapter 2. Background

The number of consumer electronics and communication technologies owned by common households have been increasing significantly in the recent decades. These devices draw “standby power” continuously 24 hours a day, even when they are switched off [7]. The only way to prevent standby power consumption is to unplug the device completely; however, that is inconvenient and inefficient. Therefore, millions of electrical appliances are continuously wasting energy in standby mode. Individual electrical appliance does not drain a large amount of standby power; however, the increasing number of electrical appliances in common households accumulates to a significant amount of power drawn. For example, [8] reported about 43 TWh of residential electricity in U.S. homes was consumed in standby mode in 1998. The IEA predicts standby power consumption in 2030 could account for up to 15% of the total household appliances electricity usage in Europe [2].

**Table 1-1. Power Consumption of Electric Appliances [9-10]**

Appliances	Average Standby Power		Daily Operating Time in Standby Mode (Hours)	Average Active Power (W)
	Real (W)	Apparent (VA)		
PC and Monitor	4.4	21.2	22.3	76.2
Printer	2.6	9.7	23.9	77.6
Laundry Machine	1.3	2.8	23.1	223.3
Laptop	0.6	5.4	20.8	18.7
Microwave	0.7	4.3	23.8	812
Rice Cooker	5.1	6.3	14.1	36.5
Coffee Machine	5.4	6.3	14.1	36.5
Home Audio Speaker	6.8	15.8	22.9	57.9

Refrigerator	1.3	8.9	7.99	137.2
37-inch LCD	14.7	20.2	23.1	217.1
Air Conditioner	0.9	3.0	20.6	1193.2

The table presents average standby power consumed by common appliances and the average amount of daily consumption compared to average active power. Most devices consume a small amount of standby power; however, it accumulates to 10-15% of total power consumption because of numerous electronic devices and hours operating in standby mode. Therefore, eliminating standby power consumption introduces significant impacts to the environment, sustainable resources, and energy consumption.

The International Energy Association (IEA) has attempted to reduce standby power losses by proposing the One-Watt Initiative in 1999, which required the standby power consumption of all electrical appliances to be below 1W [2]. In addition, many engineers and facilities around the world have designed and researched methods to reduce standby power consumption. For example, in the IEEE article [11], the engineers implemented a single-input-single-output standby power saving socket utilizing PIR and load current sensors to reduce standby power consumption to nearly 7mW. In the IEEE article [9], the engineers managed power consumption by usage profiling to predict when to provide power or shut off power to reduce standby power. In this project, Standby Power Saving Surge Protector, improves on the ideas in [11] to create a single input multiple outputs system for multiple devices to be plugged into the surge protector. The project also uses a PIR sensor and a load current detector circuit to determine when to shut off power and when to provide power to the connected devices.

## Chapter 3. Requirements and Specifications

Figure 3-1 shows the Level 1 – functional requirements of the proposed power strip. The Microcontroller Unit (MCU) acts as the brain of the system by controlling the primary functionality of the project. The MCU wakes up by signal from the Proximity Infra-Red (PIR) sensor and turns on the main power SSR to transfer power from the source to the load. After a certain amount of time, the MCU checks the load current sensor to shut off power to devices not in working state. The MCU also wakes up by a signal from the operation voltage sensor circuit to turn on the battery charge SSR to charge the battery back to its operation voltage of 5.0V. Then the MCU enters its sleep mode to reduce power consumption. The MCU will only wake up to charge the battery, when it falls below operating voltage level or when a user approaches. The entire circuit operates between 3.1V and 4.2V, so the battery acts as a power source for the DC components in the system. When the device is first plugged in, the user needs to wait 10 seconds after pressing the start button for the battery to charge up to operation voltage or working voltage level for the MCU. The PIR sensor module detects motion by using infrared light radiating from objects or human bodies nearby to detect approaching users by generating a 3.1V - 4.2V signal to wake up the MCU. The current sensor detects when connected devices enter standby power mode by monitoring working and sends a voltage signal to the MCU. The load current sensor circuit induces a small sinusoidal voltage when current passes through it. The induced voltage is then amplified and inputted to the MCU ADC module to determine whether device is in work state or not. The battery charge SSR acts as a power switch that transfer power from the AC power source plug to the AC/DC converter by a signal from the MCU to charge the battery. This function saves power consumption of the AC/DC converter during sleep mode. The main power

SSR acts as a power switch that transfer power from the AC power source plug to the connected devices by an output signal from the MCU. When the PIR module detects the user the main power SSR is turned on and stays turned on if connected devices are working but the PIR module does not detect the user.

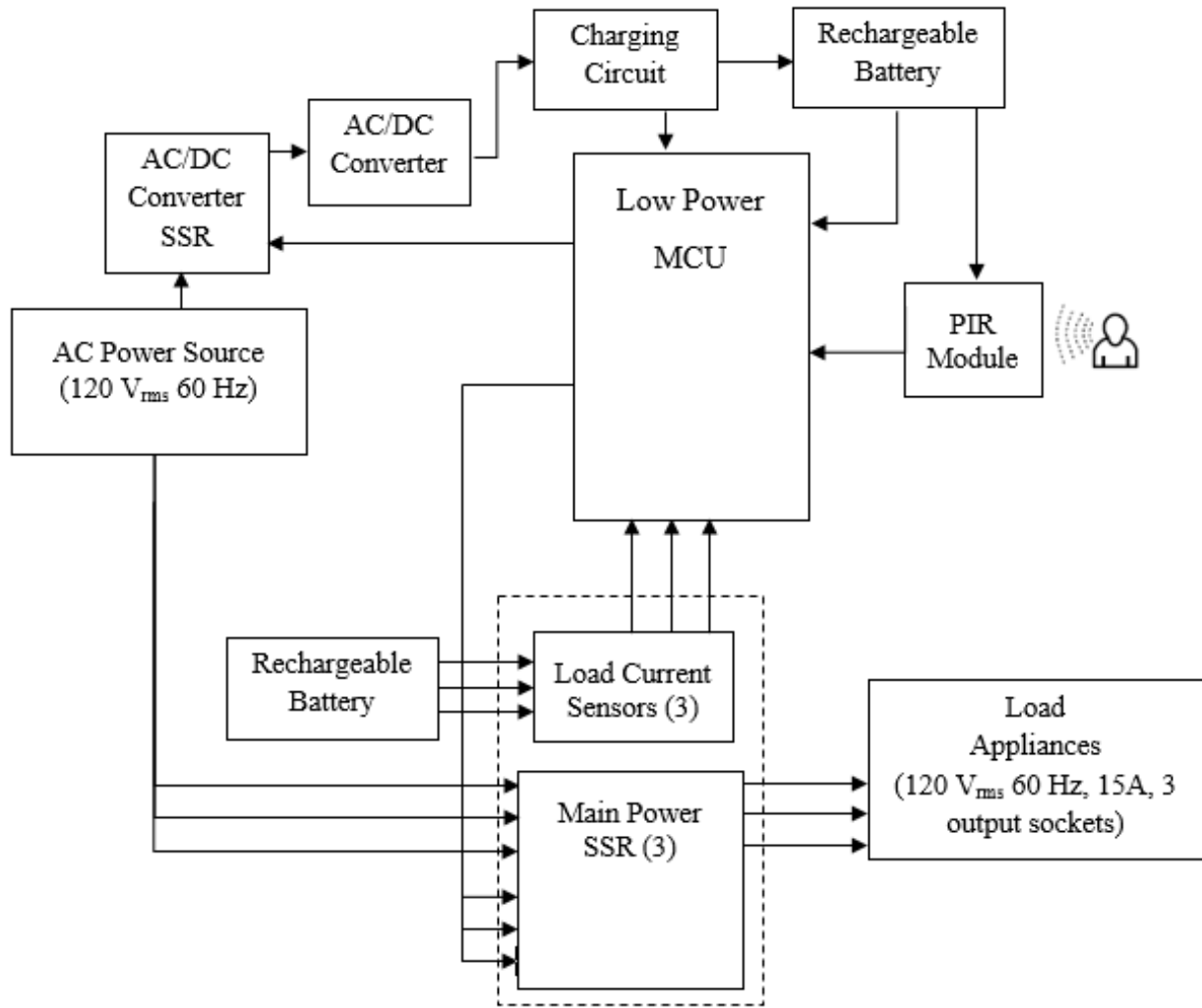

**Figure 3-1. Level 1 Power Strip Design Functionality**

The specific technical design specification and goals are summarized in Table 3-1. The circuitry used in the proposed stand-by power strip will have to fit in a standard power strip. The

number of AC plugs on the power strip will be at least two so the design can be tested with more than just a single load.

**Table 3-1. Power Strip Functionality Summary**

<b>Module</b>	<b>Inputs</b>	<b>Outputs</b>
MCU	Power from battery: 3.1V – 4.2V Induced sinusoidal voltage from the load current detector. PIR sensor module: Logic High – 3.1V-4.2V Logic Low – 0V	Main Power SSR Battery charge SSR
PIR Module	Power from battery: 4.2V Motion or approaching bodies.	Logic Levels to MCU: Logic High – 3.1V - 4.2V Logic Low – 0V
AC/DC Converter	Power: 120V AC <sub>RMS</sub> , 60 Hz 15A rating	Battery: 4.2V
Load Current Sensor	Power from battery: 4.2V Current from load (electrical appliances).	Induced sinusoidal voltage proportional to the amplitude of used current.
Rechargeable Battery Module	Power from charging circuit: 4.2V	DC Voltage between 3.1V – 4.2V to the MCU, PIR module, and load current sensor.
Main Power Solid State Relay (SSR)	Power from AC power source Signal from MCU	120 V AC <sub>RMS</sub> @ 60 Hz
AC/DC Converter Solid State Relay (SSR)	Power from AC power source Signal from MCU	120 V AC <sub>RMS</sub> @ 60 Hz

## Chapter 4. Design

The surge protector's purpose is to expand on current usage of power strips to autonomously save power consumption caused by standby power or "power vampire" in common home appliances. The Standby Power Saving Surge Protector has four main parts to design and test. First, the device needs to have a MCU to receive signals from sensors to determine when to provide or disconnect power to connected appliances. Second, it needs a current sensor to monitor when the connected appliances are providing working current or standby current. Next, the device will also require a proximity infrared sensor to tell the MCU to prepare to provide power to the connected devices, when it detects a user is within the vicinity of the connected appliances. Lastly, a rechargeable battery system and a voltage regulator are needed to operate main DC voltage components. The rechargeable battery system was implemented in the design, because it drains less power giving a more efficient system, and cheaper than connecting a direct AC-DC block to the system.

The design uses the microcontroller chip, ATmega328P, shown in Figure 4-1, as the brain of the design to provide the autonomous function of the project from receiving signals. The chip was chosen for its lower power operation capability and ultra-low standby power mode to improve efficiency, while operating the necessary tasks. In addition, the chip has an internal comparator necessary to operate the required task of checking the current sensor for working current or standby current. After obtaining the required hardware specifications for the MCU, the software to operate surge protector needs to be designed. In Figure 4-2, the flow chart presents the logic and process of the surge protector operation that need to be coded.

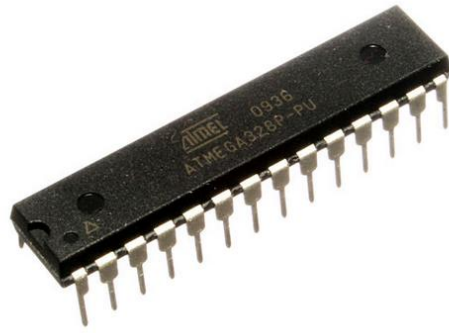

Figure 4-1. ATMEGA328B Microcontroller Chip

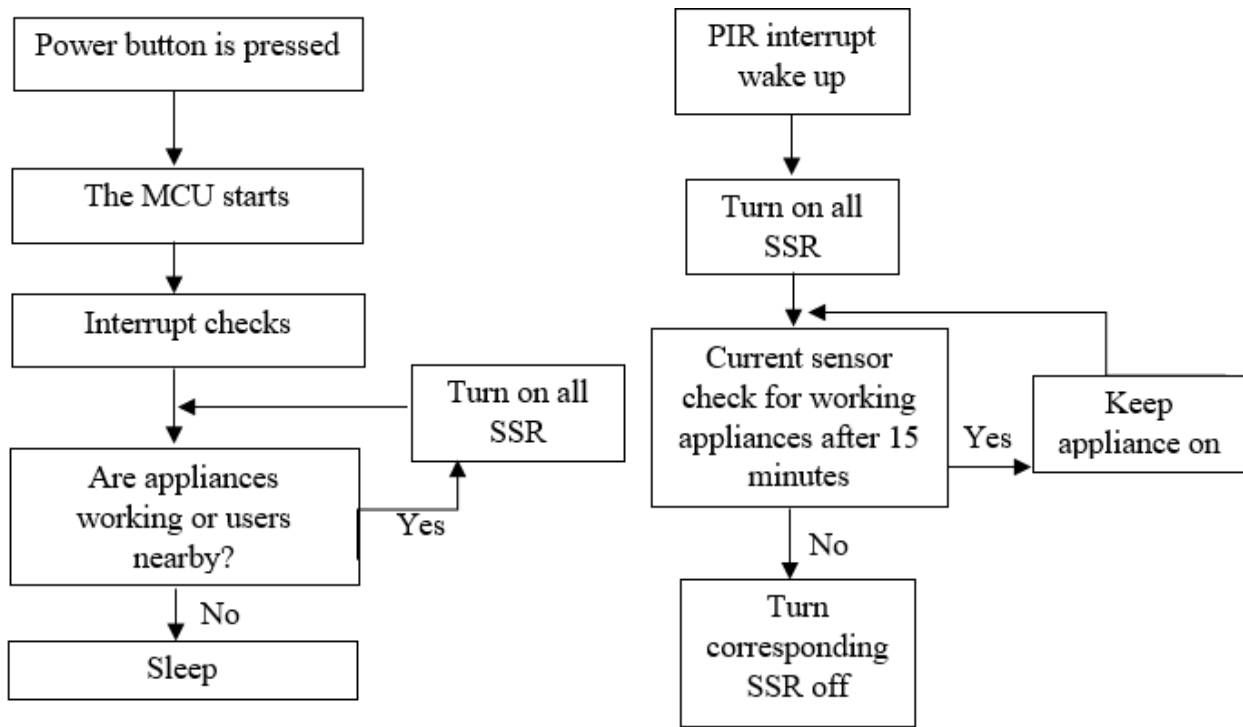

Figure 4-2. Software Block Diagram of Standby Power Saving Surge Protector

The surge protector needs to be able to handle three outputs and have a 15A rating, therefore the design needs to consider parts that are able to handle at most 120VAC at 15A. The current sensor chip, CQ-320B shown in Figure 4-3, was chosen for the design because it can sense from -20A to 20A and operate at the same supply voltage as the MCU, 3.3V-3.8V; being able to operate at this supply voltage range makes it easier to operate all the DC components at

roughly the same voltage range without needing a voltage regulator. The CQ-320B outputs an analog voltage proportional to the AC/DC current it detects, which goes into the MCU's comparator.



**Figure 4-3. AKM CQ320B Current Sensor Chip**

Next, the PIR sensor, Parallax 555-28027 as shown in Figure 4-4, was chosen because it can detect movement up to a 20ft radius with 360° viewing angle at optimal conditions. The surge projector's objective is to be used in medium sized room like a living room or bedroom, where having 20ft radius viewing angle should be large enough to cover the entirety of the room, wherever the surge protector is placed in the room. The viewing angle provide the most optimal operating condition for the design. The PIR sensor can also operate at the same voltage as the MCU making it easier to operate all the main components at the same DC voltage.

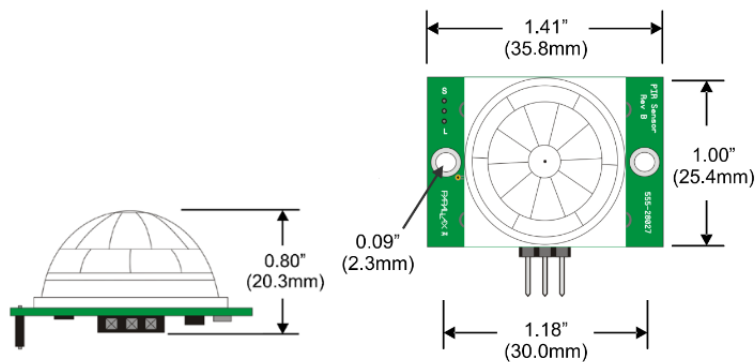

**Figure 4-4. Parallax 555-28027 PIR sensor**



Lastly, the design needs three solid-state relays (SSR) for three outputs to allow AC voltage to flow from the wall to the connected appliances and to be controlled by the MCU. The MCU sends a DC signal to the relays when it needs AC voltage to flow to the connected load and does nothing when the load do not need the AC voltage. The uxcell SSR-25DA as shown in Figure 4-5 was chosen because it can handle up to 380V AC at 25A and can be toggled by a 3V DC, which are within the requirements for the design.

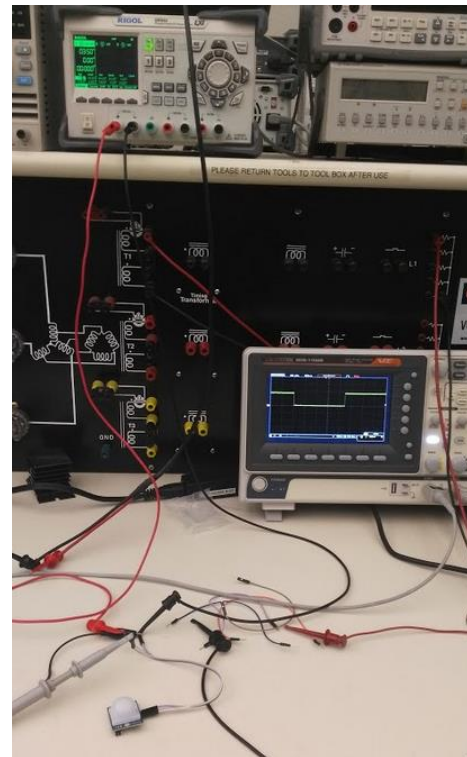
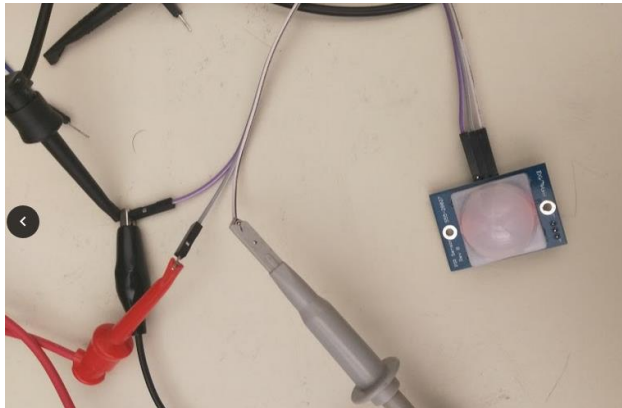

**Figure 4-5. Uxcell SSR-25DA Solid State Relay**

## Chapter 5. Hardware Test and Results

### PIR Sensor Test

The hardware implementation started with testing the functionality of the PIR sensor, by powering the sensor with 3.5V from a DC power supply and observing the output waveform on the oscilloscope, when the sensor outputs a high or a low logic signal. Figure 5-1 shows the lab bench set up with the RIGOL DC power supply and Gwinstek oscilloscope connected to test the PIR sensor functionality. Figure 5-2 shows the waveform of the PIR sensor is working as intended; when the sensor senses an approaching person or movement the sensor glows red and outputs  $\sim 3.5V$  or the  $V_{dd}$  voltage.



**Figure 5-1. PIR Sensor Test Bench Setup**

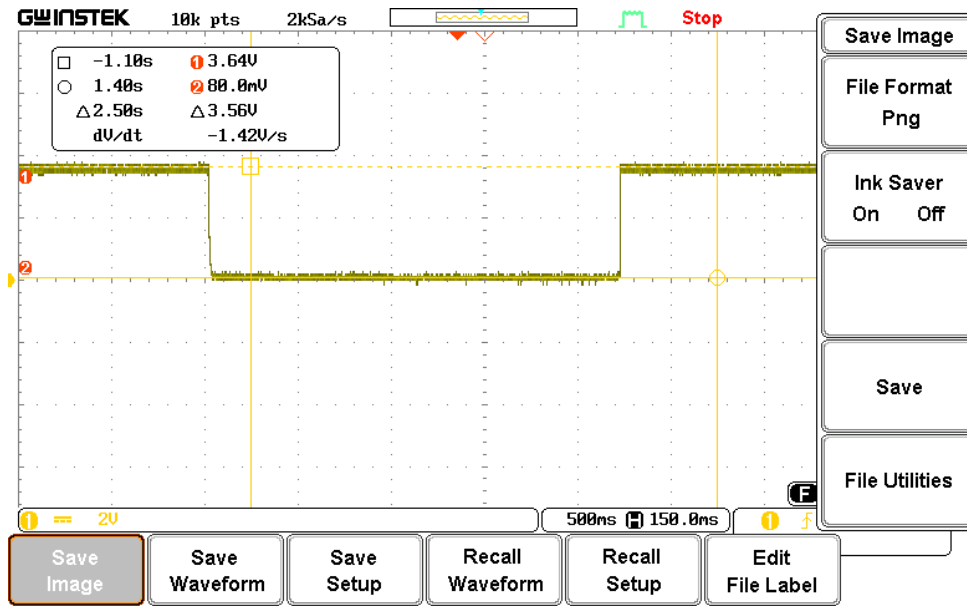

**Figure 5-2. Oscilloscope Capture of PIR Sensor Functionality**

### Solid State Relay Test

The SSR need a 3-20VDC signal to toggle the SSR between logic high and logic low mode or to transfer 24-380VAC or not. In addition, the SSR is designed to switch at the zero crossing, so it is expected for the SSR to turn on or off, when the DC signal toggle and the AC sinusoidal waveform crosses the zero voltage. To test this functionality, an Agilent Waveform Generator is configured to send a  $3.5V_{\text{peak-peak}}$  with a 1.75V DC offset square wave signal at 6 Hz to the DC signal input of the SSR. Then, a 30VAC source is connected across the SSR with a resistor in series to the positive terminal to provide an AC voltage across the SSR. Figure 5-3 presents the test bench set-up and how the oscilloscope was connected parallel to the SSR to view its functionality. The oscilloscope capture is shown in Figure 5-4, confirming the SSR toggles at the zero crossing and functioning as intended.

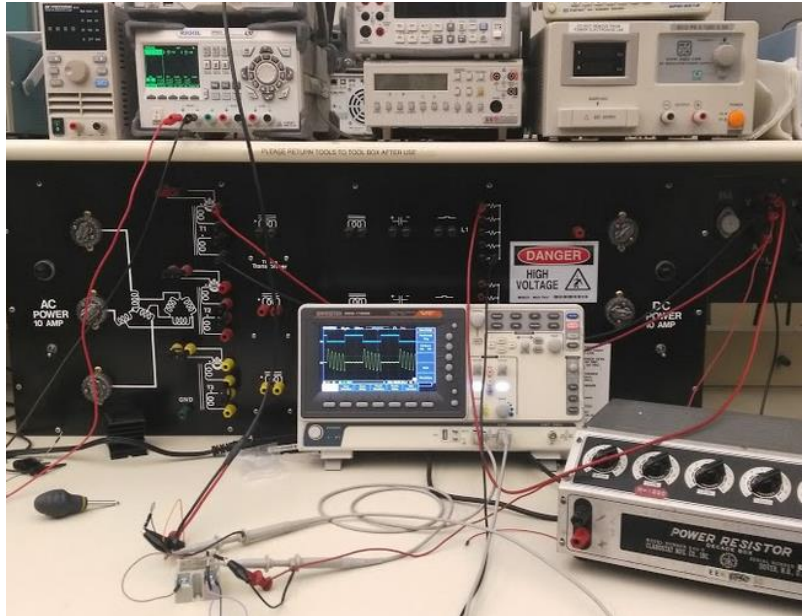
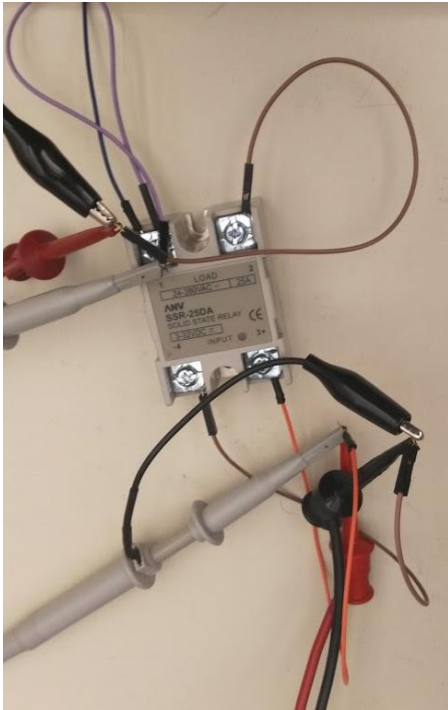

Figure 5-3. SSR Test Bench Setup

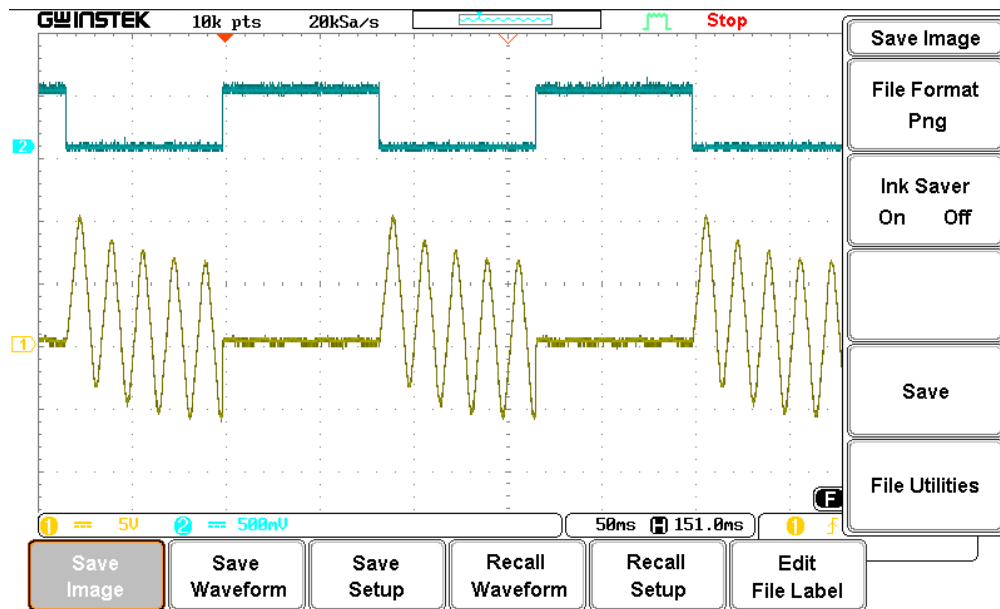
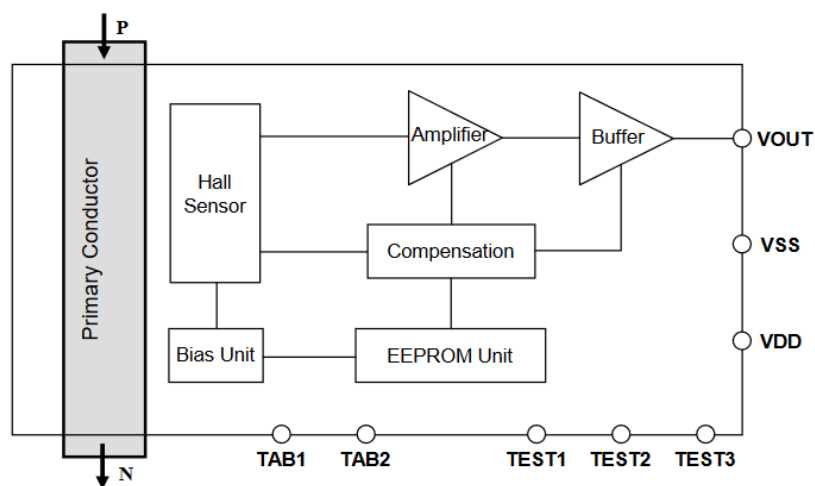

Figure 5-4. SSR Functionality Waveform

## Current Sensor Test

The current sensor, AKM CQ320-B, is an open-type current sensor using a Hall sensor, so the sensors need to be connected in series to the AC power line to get a current reading. Figure 5-5 shows the functional block diagram of the AKM CQ320-B current sensor used in the hardware implementation, where pins TAB1, TAB2, TEST1, and TEST3 are connected to the ground pin VSS and pin TEST2 is connected to the power pin VDD. To test and verify the functionality of the current sensor, a simple resistor circuit using a 10W power resistor was set up with the current sensor in series with the primary power line. The resistor is connected in series with an Agilent DC power supply or a Rigol Waveform Generator to test both DC and AC currents. The objective of this set up is to determine the output voltage level at different current and to calculate the maximum voltage output at 20A, which is the highest current the chip can handle. Figure 5-6 shows the current sensor test set-up and the equipment used on the test bench. The test data collected are listed in Table 5-1, showing the DC voltage output at different DC current across the Hall sensor.



**Figure 5-5. CQ320-B Functional Block Diagram**

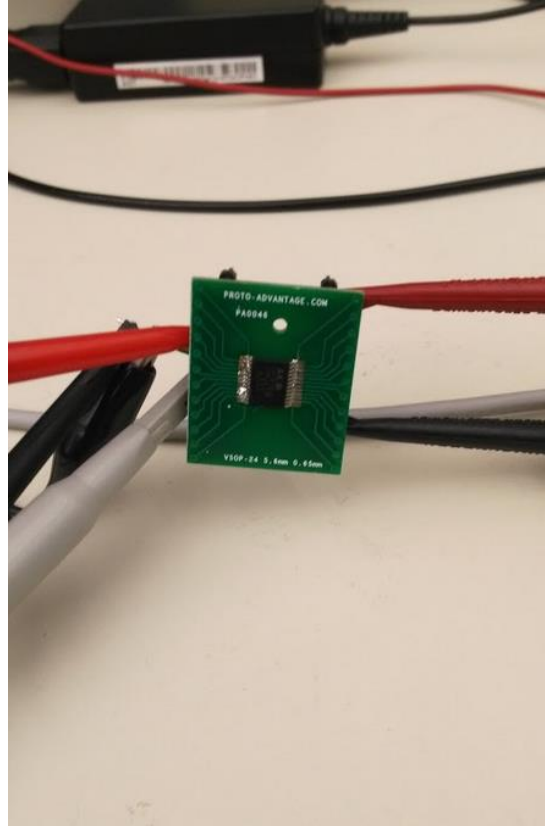
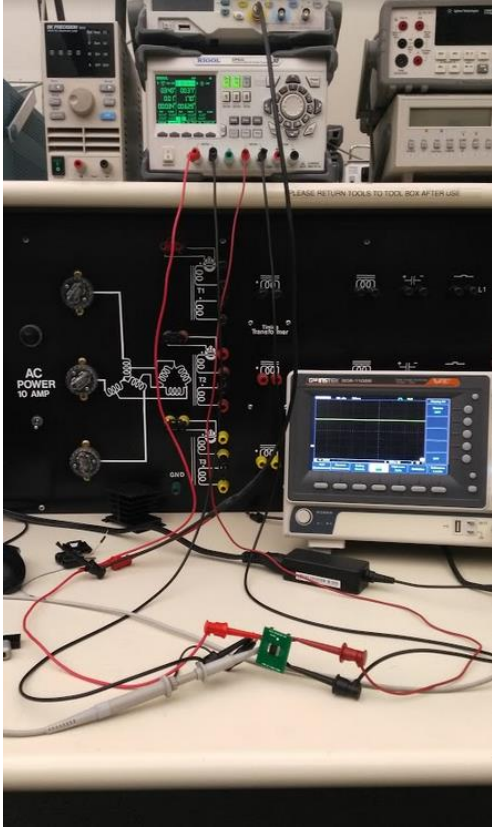

**Figure 5-6. Current Sensor Test Bench Setup**

**Table 5-1. Current Sensor Functionality Results**

Current (A)	Voltage (mV)
0.5	560
0.6	576
0.7	584
0.8	592
0.9	608
1	640
1.3	656
1.5	680
1.7	704
2	752

Graphing the data and finding a trendline shows a linear relationship between the output voltage and current as  $V = .1235x + .50$ . The equation means the chip has a zero-current output voltage of 500 mV and sensitivity of 123.5 mV/A. This result shows similarity and consistency with the datasheet values for zero-current output voltage of 450 mV and sensitivity of 120.0 mV/A, so the current sensor chip is working as intended. The microcontroller requires a maximum voltage output at 20A to generate a range of values that determines when the connected appliances is in standby power mode or not; therefore, using the equation and sensitivity of 123.5 mV/A the voltage output at 20A is 3V.

### **Complete System Test**

The setup needs to test two conditions on the system: the system needs to turn on everything when the PIR sensor detects a person and the system needs to shut off the connected appliances when no working current is detected or keep the appliances on when there's a working current even if the PIR sensor does not detect a person. The setup began with connecting all components requiring DC power and signals to the microcontroller. Next, one SSR has a current sensor and a PC monitor connected in series to test working current detection, while the other SSR is left open to test no working current detection. Figure 5-7 shows the complete test setup with the PIR sensor logic and working current detection working as intended. The PIR sensor turns on PC monitor when it detects a person and keeps the PC monitor on because a working current is detected. Figure 5-8 shows a closer view of the setup with the voltage, current, and power being inputted to the PC monitor. There is a red LED indicator on the SSR to let the user know when it is on or off, which also indicates that no working current detection is working as intended to shut off the open-circuit SSR.



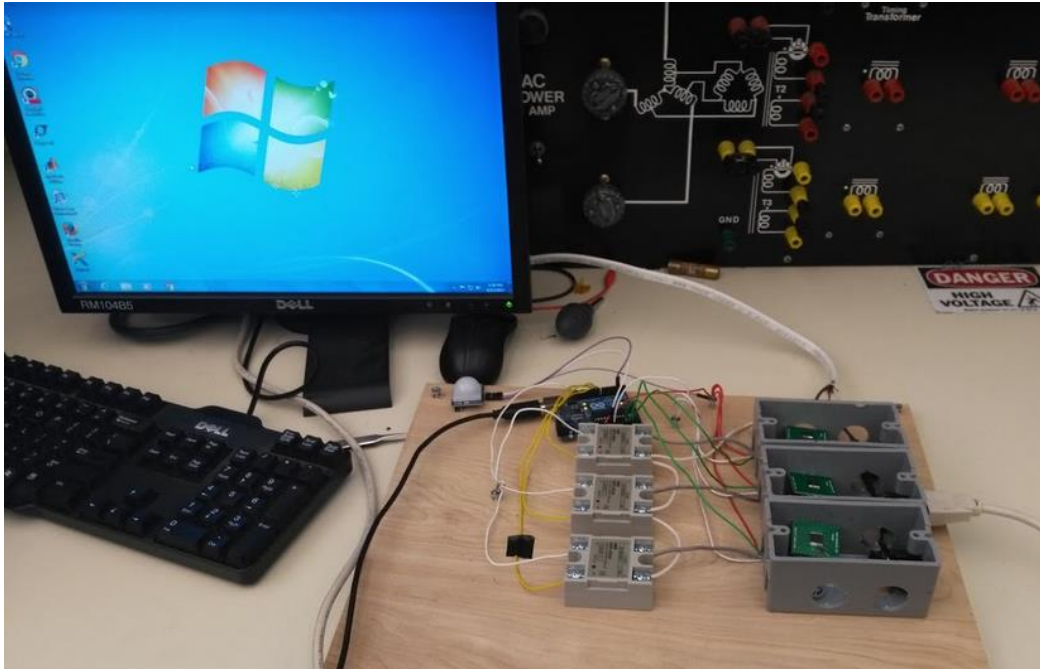

**Figure 5-7. Complete System Test Bench Setup**

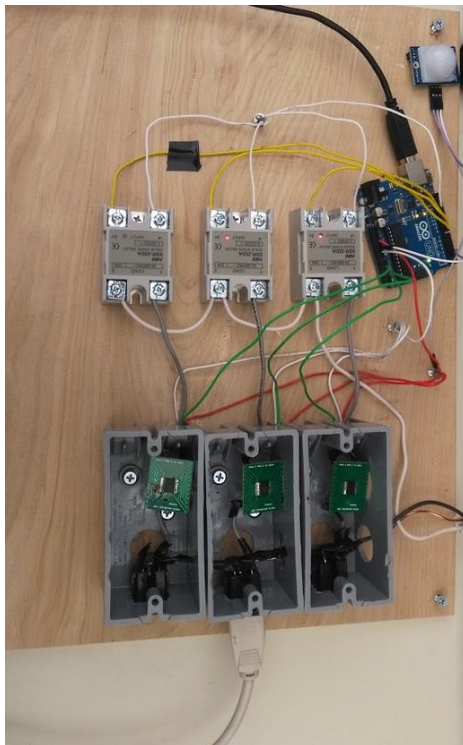

**Figure 5-8. Complete System Test Bench Setup**



## Chapter 6. Conclusion

The increase in affordability, production, and use of consumer electronics and home appliances in the recent decades have increased the number of electronics and communication devices in every households. This introduces a problem of increased standby power consumption in residential electricity. Although standby power of electronics and home appliances is not large, it affects power consumption in the long run and constitute for at least 10% of total power consumption of residential electricity. In this project, a power strip aimed to reduce stand-by power was designed, built, and tested. The design works by detecting when to turn on and off devices for primary usages and for shutting off standby power consumption. With the design working as intended, it can reduce or eliminate standby power of multiple devices in exchange for a smaller amount to power the MCU. However, the design still requires additional work to refine and improve the device, such as choosing a better PIR sensor, because the Parallax 555-28027 PIR sensor does not work as well as stated in the datasheet. In addition, reducing the components' size will also be crucial in the design since eventually the system which includes sensors, relays, and power supply electronics must fit inside a power strip. A thorough testing of the system will also be useful to ensure the functionality of the system under various loading system and scenarios.

## References

- [1] Y. K. Ramgolam, S. Veerapen, V. Oree, A. P. Murdan and K. M. S. Soyjaudah, "Energy profiles and performance of common electrical domestic appliances," *2014 IEEE International Energy Conference (ENERGYCON)*, Cavtat, 2014, pp. 1129-1136.
- [2] International Energy Agency, *Gadgets and Gigawatts: Policies for Energy Efficient Electronics*. Paris: OECD/IEA, 2009. Print.
- [3] Taufik, *Introduction to Power Electronics*, 13th ed. San Luis Obispo: Taufik, 2016.
- [4] Almeida, Anãbal De, Paula Fonseca, Barbara Schlomann, and Nicolai Feilberg. "Characterization of the Household Electricity Consumption in the EU, Potential Energy Savings and Specific Policy Recommendations." *Energy and Buildings* 43.8 (2011): 1884-1894. Web.
- [5] "Key World Energy Statistics 2016." *Key World Energy Statistics* (2016): n. pag. Web. 11 Feb. 2017.
- [6] "IEA Expects Energy Use by New Electronic Devices to Triple by 2030 but Sees Considerable Room for More Efficiency." *International Energy Agency*. N.p., 13 May 2009. Web. 12 Feb. 2017.
- [7] Alan Meier. (2016). *Standby Power* [Online]. Available: <http://standby.lbl.gov/standby.html>
- [8] M. C. Sanchez, J. Koomey, M. Moezzi, A. Meier and W. Huber, Miscellaneous electricity use in the U.S. residential sector. Lawrence Berkeley National Laboratory, Berkeley, CA, USA, Rep. LBNL-40295, 1998
- [9] S. Lee, G. Ryu, Y. Chon, R. Ha and H. Cha, "Automatic Standby Power Management Using Usage Profiling and Prediction," in *IEEE Transactions on Human-Machine Systems*, vol. 43, no. 6.
- [10] Z. Wei, Y. Zhang, F. Jin, W. Yin and L. Wu, "Standby power consumption estimation for energy saving service," *Service Operations and Logistics, and Informatics (SOLI)*, 2014 *IEEE International Conference on*, Qingdao, 2014, pp. 16-21.

- [11] C. H. Tasi, Y. W. Bai, C. A. Chu, C. Y. Chung and M. B. Lin, "Design and implementation of a socket with ultra-low standby power," *Instrumentation and Measurement Technology Conference (I2MTC), 2011 IEEE*, Binjiang, 2011, pp. 1-6.
  
- [12] R. Ford and C. Coulston, *Design for Electrical and Computer Engineers*, McGraw-Hill, 2007, p. 205
  
- [13] IEEE Board of Directors, *IEEE Code of Ethics*, 2006,  
<http://portal.ieee.org/web/aboutus/ethics/code.html>, Cited 11-9-11

## **Appendix A. Senior Project Design Analysis**

Project Title: Standby Power Saving Power Strip

Student's Name: Trung Nguyen      Student's Signature: \_\_\_\_\_

Advisor's Name: Taufik      Advisor's Initials: \_\_\_\_\_      Date: \_\_\_\_/\_\_\_\_/2017

### **Summary of Functional Requirements**

The Standby Power Saving Surge Protector detects motion or approaching bodies to power the connected devices. Then the device looks for devices unused devices and shut off power to those devices until they perform their primary functions again. The design saves wasted energy from devices during standby power mode and saves at least 10% of household power consumptions.

### **Primary Constraints**

Refers to Chapter 3: Requirements, and Specifications.

### **Economic**

Figure A-1 and Table A-1 summarize and explain the project's development time and estimated cost of component parts. The power strips use many power electronics components and sensors distributed and manufactured by different semiconductor companies, where their engineers design and manufacture these devices from silicon, phosphorous, and other elements. The usage of these elements reduces their abundance in the Earth's resources and their abundance affects their cost.

The project's majority cost occurs during implementation and testing stages, where purchases of different parts cost both time and money. However, the project's benefits also occur in the testing stages, where experience contributes to self-growth and knowledge. Additional benefits occur when the project produces a functional automatic standby power saving surge protector and manufactures it on a commercial bias, where saves wasted standby power for consumers. Customers reap the benefits of lower electricity bills throughout the device's expected lifecycle of two years. However, it lowers electric companies' profits and incomes from residential units, which affects financial capital of those companies.

The project intends to implement a proximity sensor or motion sensor, a microcontroller, and a current sensor as inputs controls of the design. Table A-1 summarizes original estimated cost compared with the actual final cost of the design. Additional costs include testing equipment cost, labor, and tools to manufacture the project that were not included in the table. The labor cost calculation considered the project's total labor hour, an

average entry level electrical engineer salary of \$75,000 a year, and estimation using R. Ford and C. Coulson’s cost estimation formula [12]. The project’s length from January 2017 – June 2017 requires approximately 150 labor hours to complete the iterations and produce a functional product. However, the actual project only took 100 hours to completely design and build the power strip.

$$\text{Cost} = \frac{\text{Optimistic Price} + 4 * \text{Realistic Price} + \text{Pessimistic Price}}{6}$$

6

The cost estimates did not consider manufacturing the device on a commercial basis, where components cost less when bought in bulk, lower labor costs, profits the project creates, and shorter development time.

**TABLE A-1. ESTIMATED COST**

Anticipated Costs		Actual Cost	
Parts	Price	Parts	Price
NA Standard Power Sockets (6)	\$18.00	Uxcell SSR-25 DA (3)	\$24.81
Insulated Power Cord	\$7.74	Parallax 555-28027 PIR Sensor	\$12.99
Cortex M3 Microcontroller	\$7.89	US Plug AC 125V 15A Power Socket Adapter	\$7.72
PIR Sensor	\$16.80	AKM CQ-320B Current Sensor (3)	\$21.96
Passive Parts	\$8.50	Insulated Power Cord	\$7.74
Labor Costs	\$7,810	Arduino UNO Microcontroller	\$20.00
		Labor Costs	\$3,500
<b>Total</b>	<b>\$7869</b>	<b>Total</b>	<b>\$3595.23</b>

Figure A-1, shows the proposed and actual timeline for the project phases and progressions from Winter and Spring 2017. The project phases center around choosing the most optimal parts and design decisions. The product should be able to operate its main function many years without requiring any maintenance costs. The current design cost too much to be implemented in the market for common consumers, where this design is not a cost-effective product for them. Therefore, there need to be more considerations and design work to make the product more affordable, where it integrate with common power strips and become a new standard for all future power strips.

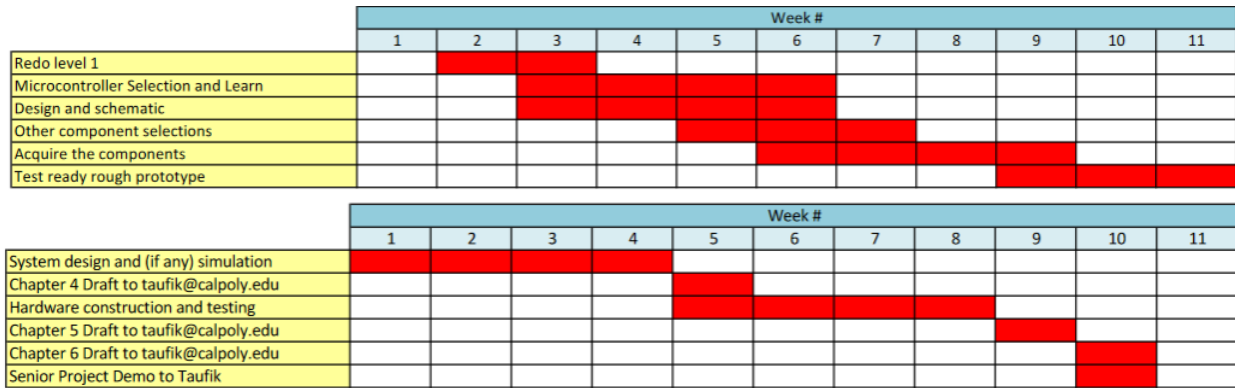

**Figure A-1. Project's Gantt Chart for Winter and Spring 2017**

**Commercial Basis**

The device faces many other competitors' surge protectors, where they're cheaper and more affordable to the lower class. For example, the Smart Strip LCG-3M surge protector implements a similar standby power saving for \$32.67, but uses a different and slightly less efficient energy saving technique. Therefore, these rival devices affect the number of devices sold per year, sale price, profit, and production cost.

$$\frac{\text{Optimistic Price} + 4 * \text{Realistic Price} + \text{Pessimistic Price}}{6}$$

6

Using the equation above, I approximated the number of devices sold per year worldwide, if the device gets manufactured on a commercial basis. I used 150,000 for optimistic devices, 90,000 for realistic devices, and 50,000 for pessimistic devices. The result calculated to approximately 95,000 devices sold per year. The device should cost around \$40 for customers to compete with competitor's lower prices, yet still high enough to make profit. An average manufacturing cost results to \$35 per device, but mass production of the device should reduce it. This creates a \$5 profit for each device and a total of \$475,000 profit per year.

**Environmental Impacts**

The design reduces residential units' power consumption and usage from electric and utilities companies, therefore, having a positive impact on the environment. For example, residential units getting power from a nuclear power plant indirectly puts waste water, waste fuel cores, and radiations into the environment. However, the design's goal to reduce power consumption leads to less harmful impacts on the environment and demands for fossil fuels. In [7], worldwide standby power consumption accounts for ~10% of residential electricity use, so reducing or eliminating this consumption has significant benefits for natural resources. Reducing that percentage significantly increases efficiency of resources used to provide residential electricity and energy, therefore benefiting the environment [10].

## **Manufacturability**

Manufacturing issues include creating a surge protector from scratch to hold the standby power saving component or implement the standby power saving circuit part into an existing surge protector, testing that a stable  $120V_{\text{rms}}$  occur across all output sockets consistently, and manufacturing a market-ready product.

## **Sustainability**

The design maintains and switches on or off at  $120V_{\text{ms}}$  often, so it's most probable that the electrical components wear out and lose its effectiveness quicker. In addition, electrical appliances connected to the device experience a similar effect of being plugged and unplugged often, which wears out components durability quicker. Buying more reliable and better parts can temporarily solve this problem, but it raises the production and part costs. The device does not have a direct impact on sustainable resources, but a significant indirect impact on Earth's resources. Worldwide standby energy consumption accounts for 10-15% of residential electricity usage [7]. Reducing that percentage significantly increases efficiency of resources used to provide residential electricity and energy, therefore benefiting the environment [10].

## **Ethical**

The design implements an improvement to the standard surge protector, that does not save wasted energy for the users. This follows the fifth IEEE Code of Ethics [13] "to improve the understanding of technology, its appropriate application, and potential consequences," through innovative design to create a more beneficial, practical, and convenient device. Saving standby power allows for more consumer electronics to exist in household, while keeping energy cost to a minimum. However, this also has a negative effect to encourage consumers to obtain more consumer electronics, which leads to increase production, wastes, energy to produce the electronics, and other harmful environmental impacts.

Additionally, standby power saving power strips follows a psychological egoism frameworks, where keeping energy cost to a minimum allow customers to own more consumer electronics in their household. This improves the customers' quality of life, but also supports a materialistic society, where extrinsic values grant contentment and happiness

## **Health and Safety**

Major usage safety concerns the design present includes faulty sockets causing electrical shorts and fire, electrical shocks from uninsulated and conductive materials touching the sockets, and electrical fire causing malfunctions with the design. However, the device's

ability to provide no voltages to open electrical outlets reduces risk of electrical shock accidents to customers or children.

### **Social and Political**

The project directly impacts most household and public residential units by saving power consumption and money on the monthly electrical bills; it also directly affects electric companies, because it lowers their profits from residents. However, the impact does not dramatically harm or benefits either parties, so the design still retain balance between the customer and electric companies. The projects benefits semiconductor companies and distributors the most, since they supply the device's primary components. Competitive prices and performance of these components determines which company becomes the primary stakeholder.

### **Development**

The IEEE articles cited in the Literature Search provided novel techniques to implement in the design for an iteration test. For example, an implementation with a proximity sensor to turn on devices when someone enters the room solves the problem the design has with knowing when and how to turn power back on to the devices.