

2012

Development And Evaluation Of A Simplified Modeling Approach For Hydraulic Systems

Yuebin Yu
yuebinyu@gmail.com

Vivian Loftness

Daihong Yu

Yan Lu

Volker Hartkopf

Follow this and additional works at: <http://docs.lib.purdue.edu/ihpbc>

Yu, Yuebin; Loftness, Vivian; Yu, Daihong; Lu, Yan; and Hartkopf, Volker, "Development And Evaluation Of A Simplified Modeling Approach For Hydraulic Systems" (2012). *International High Performance Buildings Conference*. Paper 87.
<http://docs.lib.purdue.edu/ihpbc/87>

This document has been made available through Purdue e-Pubs, a service of the Purdue University Libraries. Please contact epubs@purdue.edu for additional information.

Complete proceedings may be acquired in print and on CD-ROM directly from the Ray W. Herrick Laboratories at <https://engineering.purdue.edu/Herrick/Events/orderlit.html>

Development and Evaluation of a Simplified Modeling Approach for Hydraulic Systems

Yuebin YU^{1*}, Vivian LOFTNESS¹, Daihong YU², Yan LU³, Volker HARTKOPF¹

¹Center for Building Performance and Diagnostics, Carnegie Mellon University, Pittsburgh, PA, U.S.A
yuebinyu@gmail.com, loftness@cmu.edu, hartkopf@cmu.edu

²Department of Architectural Engineering, University of Nebraska- Lincoln, Omaha, NE, U.S.A
daisy.energy@gmail.com

³ Corporate Research of Siemens Corporation, Princeton, NJ, U.S.A
yanlu@siemens.com

* Corresponding Author

ABSTRACT

This paper presents how a hydraulic system can be properly modeled for hydraulic balancing, knowledge of flow distribution, coupled simulation, and evaluation of control, etc. It focuses on water-based heating and cooling systems, which generally have high energy efficiency in design but could perform poorly in reality due to the under-sensing condition and strong thermal-hydraulic coupling. The study introduces the motivation, presents the simplified modeling methodology, and illustrates the model and simulating structure. A preliminary evaluation of the method is conducted with two simple simulations. The proposed “node-branch-state” modeling approach could be easily modified, expanded and integrated into a detailed thermal model. The paper concludes with some discussions on future work.

1. INTRODUCTION

The main purpose of heating, ventilation and air-conditioning system is to obtain a comfortable indoor climate. At the mean time, minimum energy consumption and little or no operational problems are desired ideally. Compared to air-based systems, radiant heating and cooling systems are well known for the feature of low energy consumption and high thermal comfort (Gong, 2010, Yu, 2010, Laouadi, 2004). The overall performance of a air conditioning system and the energy efficiency rely not just on the system design and construction, but more importantly on the sensing, controlling, and actuating systems. A lot of research described that despite the improved efficiency of individual components, the faults and inferior operation waste about 20-50% of the current energy use in buildings. With existing buildings dominating the building energy consumption, the research focuses to achieve tangible high energy efficiency of building systems should be operation oriented. Mean while, in practice, due to the lack of sensing or zero-sensing redundancy in building mechanical system, even the most sophisticated controllers do not always function efficiently. This is especially true to a hydraulic heating and cooling system where the water distribution is influenced by the pipe pressure, the actuator nonlinearity, and the valve nonlinearity.

Unlike a variable air volume terminal box, where the airflow rate and discharge air temperature are measured and cascaded proportional integral (PI) controllers are employed, the terminals in a hydraulic system typically do not have measurements on the water flow rates. The controllers are relatively simple as one-time tuned PI controllers for the low cost on initiating and maintenance. It becomes difficult to evaluate the performance and therefore conduct proper control actions on the valves in advance if a prediction control is desired. The situation could be even more complex when there are multi-pump powered branches and compact piping present in the system. In addition, as

Macleod (2008) pointed out that, while the water-based central heating system is relatively cheap to run, it is also tended to be wasteful. Compared to the electric counterpart, the control of water-based system is often rudimentary and energy usage information is not well aware by the end users to the same extent as in electric system.

Models and simulation could help control and operation by providing extra information than basic sensors in the circumstance of improper or lack of sensing in the system. Yu et al (2011a) proposed a virtual calibration of supply air temperature sensor for rooftop units to obtain the correct information on the measurement. The real value of supply air temperature is critical in many aspects closely linked to energy efficiency, e.g. stage control of heating and cooling, economizer, and outside air intake control, fault detection and diagnostics etc. The model was also found to exhibit excellent robustness in terms of the knowledge of the airflow rate as a low cost virtual sensor (Yu et al 2011b).

Many researchers have investigated the approaches to improve the energy efficiency and thermal comfort of a hydraulic system for heating. Yu et al (2010) utilized a combination of system identification and numerical optimization on a floor radiant heating system. It is found that a significant amount of energy could be saved if a dynamic warming-up process can be utilized before the space is occupied. Liao and Dexter (2004) studied the energy saving potential of a heating system for energy savings by improving boiler controls. Kulkarni and Hong (2004) utilized a state-space sensible heat transfer model to optimize the control of a residential conditioning system. However, none of the aforementioned study considered the influence of hydraulic coupling and distribution on the thermal performance of the hydraulic system.

There have been few studies that investigated the thermal performance of a hydraulic heating/cooling system by coupling the hydraulic distribution network and thermal system together. Gamberi et al. (2009) utilized steady-state model to investigate the performance of a heating system by solving the coupled hydraulic distribution and thermal system. However, their study did not consider the discontinuity caused by pump ON/OFF and valve OPEN/CLOSE due to the room air temperature control. Henze and Floss (2011) studied the temperature degradation features in hydraulic cooling system by solving the coupled water distribution and thermal systems. Similarly, the approach of using Kirchhoff circuit law does not suit the situation when part of the loop is broken with any included valve at the OFF position. KN Rhee et al. (2010) conducted a simulation investigation of hydraulic balancing to improve the room temperature control for a radiant floor heating system. In their study, a hardware-in-the-loop approach is adopted. While the hydraulic distribution information is more reliable, the cost of construction, sensing and data acquisition is prohibitive that makes the approach impractical in real applications.

There are two challenges to address before we utilize an integrated hydraulic and thermal system simulation:

1. *For a given hydraulic network, the model should be relatively easy to acquire.*
2. *The hydraulic continuity should remain even the pumps or branch valves are off or close to the off position.*

With a conventional node-mass and loop-pressure-drop approach, the user holds the responsibility to identify the necessary loops to constitute the hydraulic network. With a relatively complex hydraulic network, it is close to mission impossible. Meanwhile, since the definition of a loop holds true only when at least one of the element branches in series is continuous, this approach does not have the flexibility to configure part of the loop offline or totally loses the continuity when the valves or pumps on any included branches are off.

This study proposes a "node-branch-state" based approach to overcome the two challenges and simultaneously solve for both pressures and flow rates. The method could be utilized to constitute a stand-alone hydraulic network model for commissioning, additional sensing, advanced control, etc. With minor modification and expanding, the model can also be easily utilized and incorporated with thermal model to conduct a thermal-hydraulic coupled simulation. While there are many studies conducted in the past on constructing and solving water distribution networks, none has discussed the handling of the discontinuity due to the ON/OFF action of valves and flow movers (Ormsbee, 2006, Strafacci, 2003). Commercial software packages are usually standalone and have many limitations on or are not possible at all for thermal coupled co-simulation.

The paper is structured as follows: The hypotheses for the hydraulic model are first laid out. The modeling methodology for hydraulic components and network is then described, with model and simulation structure further

illustrated. Two simple case studies with coupled thermal-hydraulic simulation are then presented. The paper concludes with discussion on the future work.

2. HYPOTHESES

While in this study a thermal-hydraulic coupled simulation is conducted, modeling of thermal part is not of the major concern of this article. The hypotheses of formulating control-oriented thermal models could be found in the literatures (Thomas, 1999, Yu, 2012). The following hypotheses are made for the modeling and simulation of hydraulic network part:

1. *The flows in the network are continuously evolving steady states;*

The time constants associated with the setting of flow in a hydraulic network for building applications are usually very short compared with the thermal part. Therefore, the flows can be assumed to settle instantaneously by using continuous evolving steady-state models based on mass and energy conservation laws (Bhave, 1988).

2. *The pressure drop along a pipe line and across a component can be expressed by power law to the flow rates;*

The pressure drop of a given component depends on the flow status, e.g., laminar flow, developing flow, turbulent flow (Warsi, 1998). Under most circumstances in the application of water-based heating and cooling systems, the flow can be regarded fully developed and representative resistance coefficients can be applied. The variations of fluid temperature, density, friction coefficients, et al, along the lumped components are not considered.

3. MODELING METHODOLOGY

3.1 Hydraulic Model

Hydraulic Network:

The basic categories of the components existing in a large hydraulic network can be divided into two as: joint nodes and through branches to establish the governing equations. Fig. 1 illustrates the liquid flow network with one joint node and three through branches. The balance equations serve as the base to the modeling of a hydraulic network that links multiple components. For a joint node, where there are greater than two though pipes are linked to it, a mass conservation must hold that the summation of inlet flow rates at any given node (e.g. i th node) from 1 to N equals to the summation of outlet flow rates. N is the total number of the joint nodes in the hydraulic network.

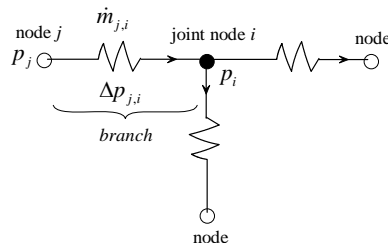

Figure 1: Liquid flow network with one four nodes

$$0 = \sum_{i,j \in \mathcal{E}} \pm \dot{m}_{j,i} \quad (1)$$

The mass flow rates are directional in the formulation of mass equations. It does not matter which direction is defined as positive flow, as long as the signs do not conflict for the flow through the same branch for two neighbor nodes. For automated model generation, for example, all nodes are considered as sinks by default with all flows toward the joint node, a negative sign should be added to the same branch if it appears second time in the mass balance equations. While with this balance equation any physical node in a network can be treated as a node in a model, simplification is encouraged to combine the trivial ones by using series or parallel analysis. The same holds for the processing of loops, branches and components.

The total number of mass conservation equation equals to the total number of joint nodes. Besides the joint nodes, there might also exist nodes that define the boundary of a subsystem in a loop. One example will be the inlet and outlet of a secondary loop that link to the primary heating and cooling system. The total flow balance equations

equal to the total number of the nodes in the network. The total number of the flow rates that need to be solved in a hydraulic network equals to the total number of the branches.

In addition to node mass conservation, the mechanical energy conservation holds for all the through branches with continuous fluid. Using the energy conservation across a branch is more convenient and intuitive than applying the energy conservation law of loops. The necessary number of loops for solving the hydraulic unknowns is difficult to identify for a large scale network (e.g. as the system in Fig. 2). Meanwhile, a valve at fully close position disables all the predefined loops that have the valve included. For example, in Fig. 2, valve DV2 at close position deactivates all the nodes and branches up and down stream between node 12 to node 20. A state in “node-branch-state” based hydraulic model approach refers to the ON/OFF condition of any pumps and valves in the network, whose change could lead to totally different network continuity and the effectiveness of the governing equations.

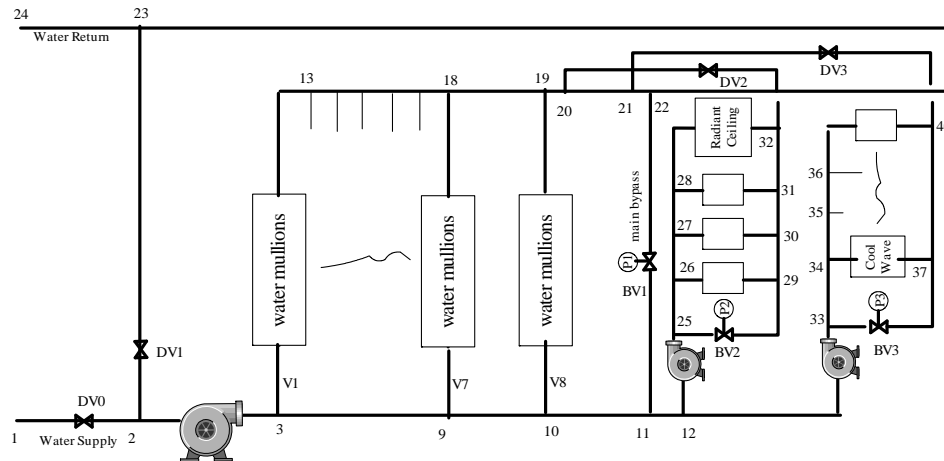

Figure 2: Illustration of a secondary heating and cooling hydraulic network

Bernoulli's principle states that an increase in the speed of the fluid occurs simultaneously with a decrease in pressure or a decrease in the fluid's potential energy (Batchelor, 1967). Accordingly, the general expression of the energy balance for a continuous fluid without power component is:

$$p_i + \rho \cdot g \cdot h_i + \frac{1}{2} \cdot \rho \cdot v_i^2 + \Delta p_{j,i} = p_j + \rho \cdot g \cdot h_j + \frac{1}{2} \cdot \rho \cdot v_j^2 \quad (2)$$

A pressure drop across the components on the branch with continuous fluid needs to be identified to get the gauge pressure at the individual node of the hydraulic system. In most building hydraulic thermal system, where a closed loop is applicable, the energy due to the height difference and the kinetic element in a branch can be ignored for simplification. A characteristic coefficient is employed to represent the major and minor pressure loss across the branch for the pipe, fittings, coils, etc:

$$\Delta p_{j,i} = S_{j,i} \cdot \dot{m}_{j,i}^\alpha \quad (3)$$

There are many different components that exist on a hydraulic branch, including resistor components (e.g. valves, pipes, coils, fittings, etc) and power components (pumps). Valves can be controlled to modulate the flow by either reducing or adding additional resistance to the branch. Pumps are the power components that circulate the flow by adding head to the fluid. When a pump changes from ON to OFF, it shifts from a power component to a resistor component. The handling is considered in this proposed “node-branch-state” modeling approach.

Resistor components:

The static part of the resistor components of a branch, including pipes, coils, and fittings, can be expressed as one consolidated component with the resistance calculated and summed altogether. The value of the coefficient once identified remains constant:

$$S_{j,i,s} = \sum_k \frac{8 \cdot \lambda_k \cdot \rho}{\pi^2 \cdot d_k^5} \cdot l_k + \frac{8 \cdot \xi_k \cdot \rho}{\pi^2 \cdot d_k^4} \quad (4)$$

The valves should be considered separately since the different valve openness incurs different pressure drops across the valve. The expression is given by:

$$S_{j,i,v} = \frac{g}{k_v^2 (g)} \quad (5)$$

The total pressure drop of a branch with continuous fluid is the summation of that of the static components and the modulating valves. Since the flow rate is considered the same through all the components on the branch, the overall characteristics can be expressed as the following coefficient equation:

$$S_{j,i} = \sum_{k=1}^n S_{j,i,k} + \sum_{l=1}^m S_{j,i,v} \quad (6)$$

Similarly, the total flow rate through parallel pipes, which share the same inlet node and outlet node, is the summation of the flow rate through the individual pipe. The pressure drop across the shared nodes is the same to all the member branches. The relationship can be put as:

$$\frac{1}{\sqrt{S_{j,i}}} = \sum_{k=1}^n \frac{1}{\sqrt{S_{j,i,k}}} \quad (7)$$

The series and parallel flow and pressure drop relationships can be used to reasonably simplify the original hydraulic network before resorting to a numerical model.

pumps:

When there is a pump operating in a branch, the additional head should be added into the proper side of Eq. (2) to account for the external mechanical energy. The relationship between the pump head and volumetric flow rate can be regressed from the manufacturer data sheet or onsite measurements as:

$$H = a_0 + a_1 \cdot \dot{m} + a_2 \cdot \dot{m}^2 \quad (8)$$

If a variable frequency drive (VFD) is installed on a pump, applying the pump law on the flow and pump head (Yu, 2010), a final equation that represents the relationship under partial speed can be obtained:

$$H = \omega^2 \cdot f\left(\frac{\dot{m}}{\omega}\right) \quad (9)$$

To this end, a basic hydraulic model can be built with the proposed "node-branch-state" approach. The number of variables to be solved is determined by the complexity of system. For the simple one node system as in Fig. 1, there are three flow rate variables and three pressure drop variables, including the boundary conditions. The number of variables, mass balance equations, and energy balance equations increase greatly for a complex network. For example, in the illustrated thermal heating and cooling system in Fig. 2, there are eight water mullion terminals, four radiant ceilings, and four cool waves. The total number of nodes in the network without simplification is 40. Node 1 and 24 are at the boundary. The total number of pressure balance equations is 58 for the branches in the network. An automated model generation algorithm is needed for large scale network to avoid the mission impossible and potential mistakes of human counting as described in the next section.

3.2 Model and simulating Structure

With the prescribed simplified modeling method, it is not difficult to generate a model for a complex hydraulic network system. A handy processing tool is developed in Matlab to automatically construct the large scale hydraulic network. The size of the network matrix is node by node (40 by 40 for the network shown in Fig. 2) for model preparation. The obtained model contains the identification of the variables, the map of branches to the node connections. The condition of the boundary nodes could be a fixed pressure or mass flow rate and should be provided in addition in order to solve for the unknown flow rates across the branches and the static pressures at the nodes. The model is then encapsulated as a stand-alone block that can be called by other functions in Matlab or

model blocks in Simulink. The inputs to the model are the pump states (or, in addition, speeds if VFDs are installed) and valve openness. The outputs are the flow rates through the branches and the pressures at the nodes. Fig. 3 illustrates the program execution flow of the proposed modeling approach.

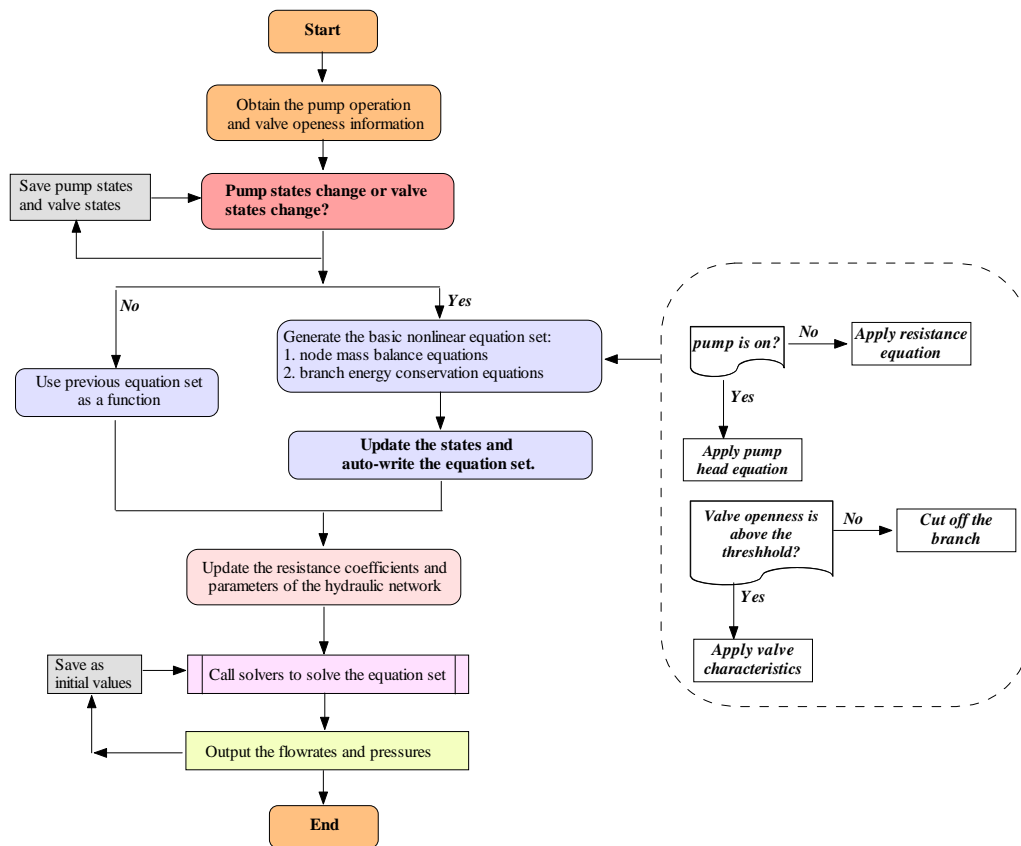

Figure 3: “Node-branch-state” hydraulic model process flowchart

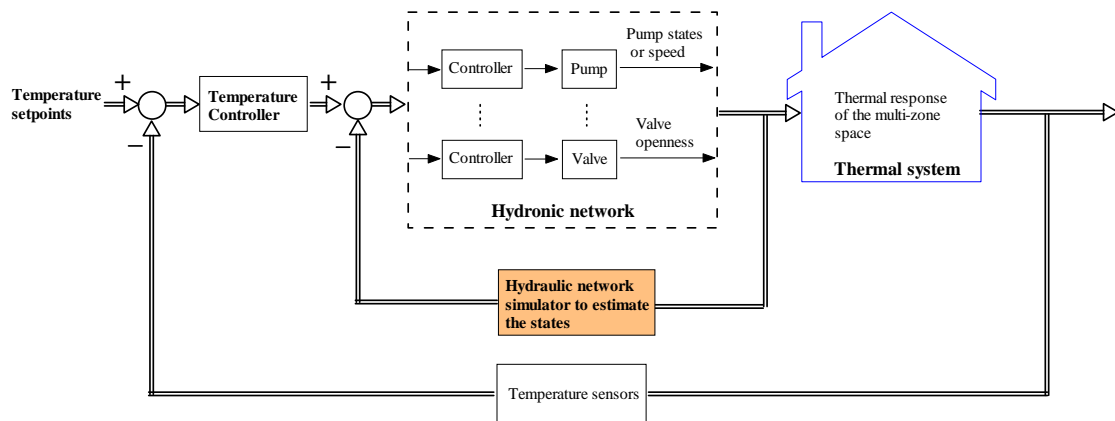

Figure 4: Example integration of the hydraulic network simulator

To conduct a cascaded control or model-based predictive control, where the thermal water flow rate through the terminals are needed, the model could be further calibrated and serve as a virtual sensor that provides all the needed hydraulic information back to the controller. Fig. 4 illustrates such a control-oriented utilization structure. The hydraulic network simulator is embedded in to take the valve and pump states from the inner controller output and provide the flow rate information back to the controller.

4. SIMULATION CASES

To evaluate the proposed modeling and simulation approach, two simulation cases, a hydraulic distribution simulation and a thermal-hydraulic coupled simulation, based on the method are conducted for the system as shown in Fig. 2. The detailed description of the building system and the thermal components can be found in (Yu et al, 2012b). The hydraulic system is taken from part of an existing water based thermal network in a test lab at Carnegie Mellon University. The pumps for the main circulation and the two local branches are constant speed pumps. The pump curves are shown in Fig. 5.

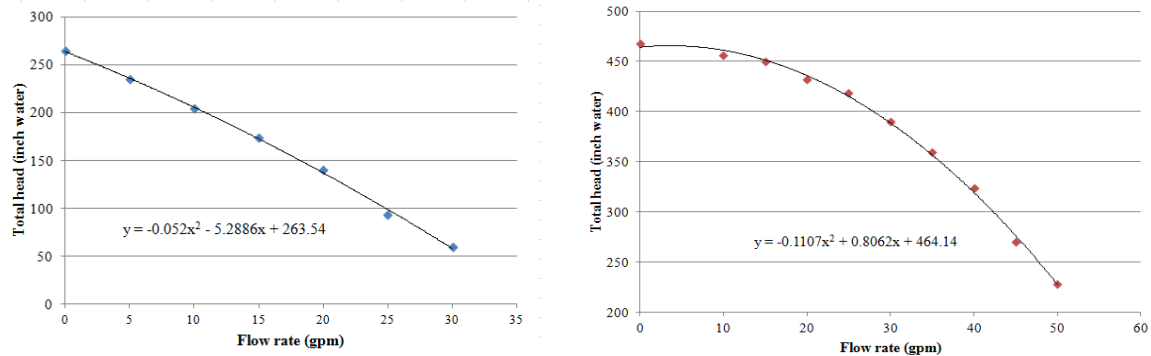

Figure 5: Pump curves for the branches (L) and main pump (R)

4.1 Case 1- Hydraulic distribution

Case 1_0: all pumps are on

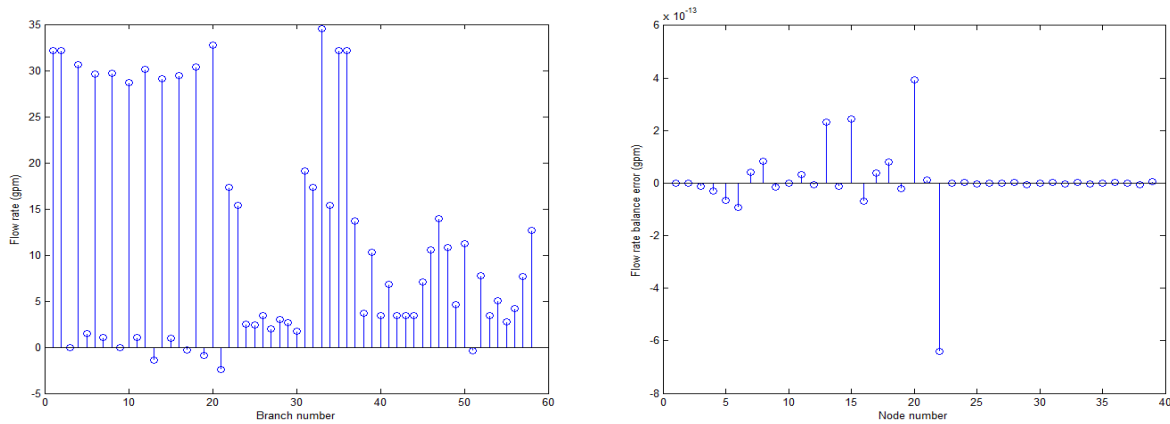

Figure 6: Water flow rate through each branch and node balance error, case 1_0

In this case, we leave all the valves, including the three by-pass valves but DV1, open. The simulation results of the water flow rates and the error of flow balance at each node are collected in Fig. 6. As shown in the figure, the water flow rates through branch 1 (between node 1 and node 2) and 2 (between node 2 and node 3) are of the same flow value with no bypass flow through DV1. Meanwhile, with the adopted hydraulic network, the water flow rate at the center through branch 20 (between node 11 and node 12) is even higher than the main inlet. The reason is that branch 20 is at the inlet of two parallel pumps. Due to the pump suction, and the balance issue with all the by-pass valve open, there are reverse flow through branch 21 (bypass pipe between node 11 and node 22), which is shown as negative flow in the chart. Also, due to the local recirculation, the flow rate through branch 33 (between node 21 and node 22) is even higher than the flow rate in the main pipe.

The information provided is rich for a detailed hydraulic network balancing analysis and control where no or very few flow rate meters are installed. The similar reverse flow also happens at a couple of other locations in the middle of the network (e.g. branch 13, 17, and 19). The solutions to the issue could be shutting off bypass valves, installing

constant flow rate valves, or installing check valves, etc. The node balance error shows that the mass at each node has good convergence. In Fig. 6, all the error is within the magnitude of 10^{-13} gpm and the majority is close to 0. The other simple checking is to compare the flow rate value for node 2-3(branch 2) and node 22-23 (branch 35), node 12-25 (branch 22) and node 20-32 (branch 32), and node 12-33 (branch 23) and node 21-40 (branch 34), as three inlet and out let pairs.

Case 1_1: the main pump is on, the other pumps are off

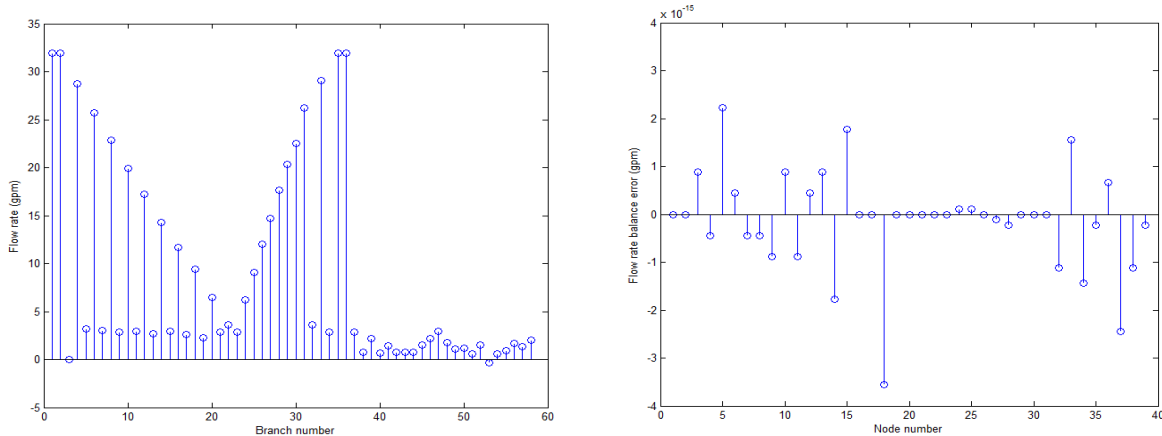

Figure 7: Water flow rate through each branch and node balance error, case 1_1

In this sub-case, only the main pump is on and the other two branch pumps are off. All the valve openness are as in Case 1_0. The simulation results are shown in Fig. 7. From the water flow rate through each branch, it can be seen, that without the two branch pumps, there is no reverse flow existing in the pipe line. The water flow rates drop along the way of the flow. The branches 5, 7, 9, 11, 13, 15, 17, and 19 (the water mullion terminals) have almost identical water flow rates at about 3 gpm each. The mass balance errors for the nodes can be regarded as zero as shown in the right chart. Meanwhile, it can be seen that, by comparing Fig. 6 and 7, without the branch pumps, the water flow rates through the branch terminals (e.g. branch 40, 42, etc) are much less than the situation with branch pumps. The water flow through the bypass pipe is as normal without reversing. The mass calculation errors for the branches near the pump are close to zero. The overall convergence is within the magnitude of 10^{-15} gpm, which indicates a good simulation. For the purpose of better allocating the water flow in the network, especially to get more water flow to the radiant ceilings and cool waves close to the end of the network, the valves of the water mullions and the bypass should be closed more or properly modulated.

4.2 Case 2- Thermal- hydraulic co-simulation

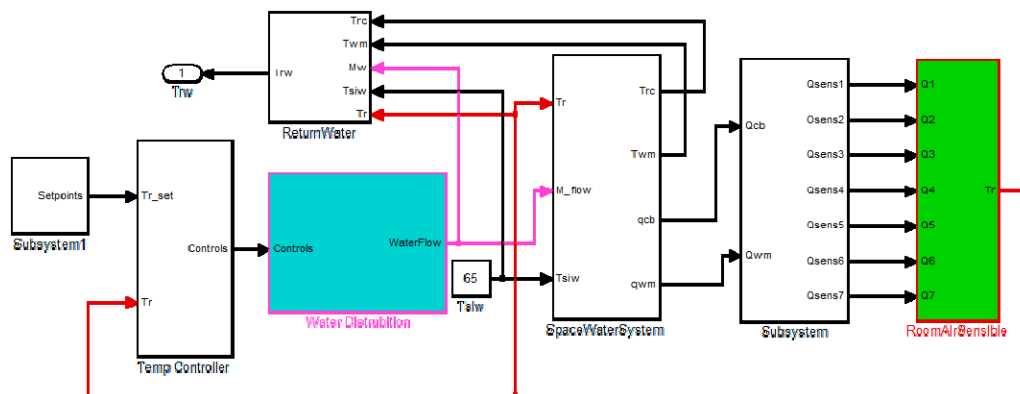

Figure 8: Simulink model for thermal-hydraulic co-simulation

The hydraulic model is embedded in a thermal model to conduct a co-simulation as in Fig. 8. For a real thermal system, since the hydraulic network model provides additional sensing information about the water distribution, the

operation strategy could be correspondingly improved to reduce the potential adverse influences. To distinguish the case from the complex hydraulic system as in the real facility, only the representative water based terminals are used for the seven zone space. The heating capacity of the lumped terminals are adjusted correspondingly to match the original ones. The simulation is conducted for one day in January with the real trended weather data.

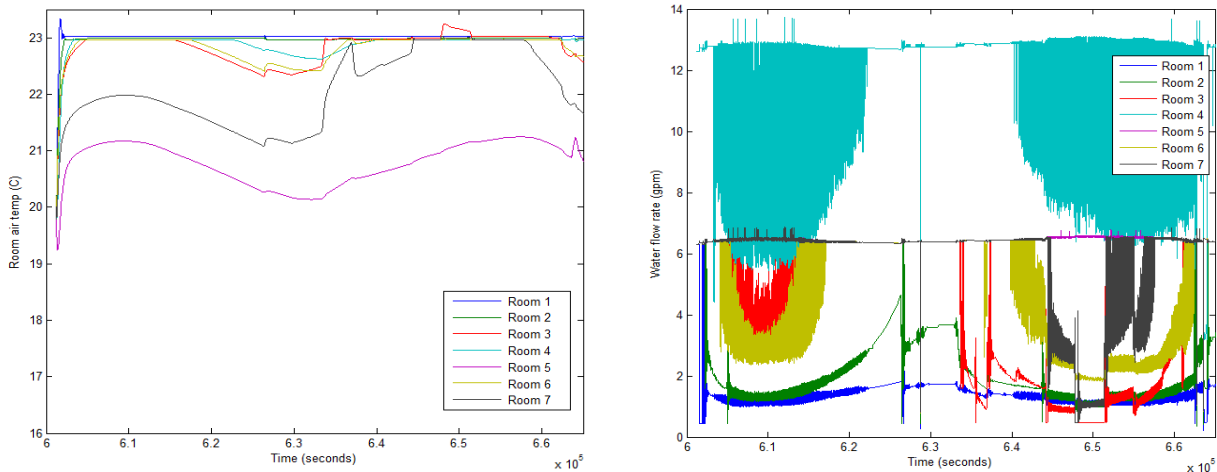

Figure 9: Simulink simulation results for 7 zones in the space
(L: room air temps, R: water flow rates)

From the results shown in Fig. 9, it can be seen that the water network has some coupling issue. The pipe in room 5 and 7 are in the disadvantage location, where the valves get starved and the room air temperature cannot be satisfied during almost the whole simulation time period. The right chart gives the water flow distribution among the terminals in the seven zones. Room 1 does not need much water to satisfy the load, while room 4 consumes the most. The water distribution simulation could tell more about the network if the bypass control and the mixing valves are further tuned.

5. CONCLUSIONS AND DISCUSSION

For water based thermal heating and cooling system analysis, a hydraulic network simulation becomes necessary in order to gain more insight of the water distribution. The more detailed water distribution information through the terminals serves as "virtual sensor" for advanced control and diagnostics. This paper proposed a simplified "node-branch-state" approach for hydraulic system simulation. This approach does not require the users to identify the loops and can handle the discontinuity issues due to pump or valve ON/OFF operation. The hydraulic system modeling method can be modified, expanded and integrated into a detailed thermal model to conduct co-simulation.

Solving a complex hydraulic system involves the iterations or optimization to obtain the solution of a large-scale nonlinear equations simultaneously, which could be time consuming. More study is needed to investigate the solver computation reliability and speed for a thermal-hydraulic coupled simulation and/or to assist the analysis of online operation strategies.

NOMENCLATURE

\dot{m}	water flow rate	(gpm)	Subscripts
$p, \Delta p$	pressure, pressure difference	(Pa or inch water)	i, j, k counting number
ρ	density	(kg/m ³)	s resistor
g	gravity	(m/s ²)	
v	volumetric speed	(m/s)	
h	relative height to the reference	(m)	
S	resistance coefficient	(-)	

α	constant	(-)
λ, ξ	friction coefficient	(-)
d	hydraulic diameter	(m)
g	valve openness	(-)
k_v	valve conductance coefficient	(-)
ω	pump speed ratio	(-)
l	pipe length	(m)
H	pump heat	(Pa or inch water)

REFERENCES

- G.K. Batchelor. 2000. An Introduction to Fluid Dynamics. Cambridge University Press.
- P.R.Bhave. 1988. Extended Period Simulation of Water Systems- Direct Solution. *Journal of Environmental Engineering*, Vol. 114 (5): p. 1146-1159.
- M. Gamberi, R. Manzini and A. Regattieri. 2009. Simulink Simulator for Building Hydraulic Heating Systems Using the Newton-Raphson Algorithm. *Energy and Buildings*, Vol. 41: p. 848-855.
- M. Gamberi, R. Manzini and C.P. Underwood. 1998. HVAC Control Systems: Modeling, Analysis and Design. E & FN Spon.
- G. Henze, A. Floss. 2011. Evaluation of Temperature Degradation in Hydraulic Flow Networks. *Energy and Buildings*, Vol. 43: p. 1820-1828.
- A. Laouadi. 2004. Development of a Radiant Heating and Cooling Model for Building Energy Simulation Software. *Building and Environment*, Vol.39: p. 421-431.
- A. Macleod. 2008. The Heating System as a Distributed Sensor Network. *Energy and Buildings*, Vol. 40: p. 1547-1552.
- L. Ormsbee. 2006. The History of Water Distribution Network Analysis: The Computer Age. *8th Annual Water Distribution Systems Analysis Symposium*. Cincinnati.
- K. Rhee, S. Ryu, et al. 2010. Simulation Study on Hydraulic Balancing to Improve Individual Room Control for Radiant Floor Heating System. *Building Services Engineering Research and Technology*, Vol. 31(1): p. 57-73.
- K. Rhee, M. Yeo and K. Kim. 2011. Evaluation of the Control Performance of Hydraulic Radiant Heating Systems Based on the Emulation Using Hardware-in-the-Loop Simulation. *Building and Environment*, Vol. 46: p. 2012-2022.
- A. Strafaci, 2003. Advanced Water Distribution Modeling and Management, *Haestad Press*, Waterbury.
- P. Thomas, 1999. Simulation of Industrial Processes for Control Engineers. Elsevier Science & Technology Books.
- Z. Warsi, 1998. Fluid Dynamics: Theoretical and Computational Approaches. CRC Press.
- D. Yu, H. Li, et al. 2011a. Virtual Calibration of a Supply Air Temperature Sensor in Rooftop Air Conditioning Units. *International Journal of HVAC & R Research*, Vol. 17(1): p. 31-50.
- D. Yu, H. Li, and Y. Yu. 2011b. A Gray-box Based Virtual Supply Airflow Meter in Rooftop Air-Conditioning Units. *Journal of Thermal Science and Engineering Applications*, Vol. 3(1): p. 1-7.
- Y. Yu. 2010. Msc. Thesis. Integrating Air Handling Units in Office Buildings for High Performance. University of Nebraska-Lincoln.
- Y. Yu. 2012. PhD. thesis. Model-based Multivariate Control of Conditioning Systems in Office Buildings. Carnegie Mellon University.
- Y. Yu, B. Dong, et al. 2010. Application of System Identification and Numerical Optimization to a Floor Radiant Heating Control in a Solar House. *Proceedings of CLIMA 2010*, Turkey.
- Y. Yu, M. Liu, et al. 2012a. Synergization of Air Handling Units for High Energy Efficiency in Office Buildings: the Theory and Analysis. *Energy and Buildings*, Vol. 45: p. 264-273.
- Y. Yu, V. Loftness. 2012b. Development of an Innovative Energy System and its Advanced Control in EnergyPlus. *Proceedings of eSim 2012*. Halifax, Canada.

ACKNOWLEDGEMENT

The authors gratefully acknowledge the support of this work from U.S. Department of Energy under award DE-EE0003843.