

Masthead Logo

University of Iowa  
Iowa Research Online

Driving Assessment Conference

2013 Driving Assessment Conference

Jun 19th, 12:00 AM

# The Design of Haptic Gas Pedal Feedback to Support Eco-Driving

Hamish Jamson

*Institute for Transport Studies, University of Leeds, Leeds, U.K.*

Daryl L. Hibberd

*Institute for Transport Studies, University of Leeds, Leeds, U.K.*

Natasha Merat

*Institute for Transport Studies, University of Leeds, Leeds, U.K.*

Follow this and additional works at: <https://ir.uiowa.edu/drivingassessment>

Jamson, Hamish; Hibberd, Daryl L.; and Merat, Natasha. The Design of Haptic Gas Pedal Feedback to Support Eco-Driving. In: Proceedings of the Seventh International Driving Symposium on Human Factors in Driver Assessment, Training and Vehicle Design, June 17-20, 2013, Bolton Landing, New York. Iowa City, IA: Public Policy Center, University of Iowa, 2013: 264-270. <https://doi.org/10.17077/drivingassessment.1499>

This Event is brought to you for free and open access by the Public Policy Center at Iowa Research Online. It has been accepted for inclusion in Driving Assessment Conference by an authorized administrator of Iowa Research Online. For more information, please contact [lib-ir@uiowa.edu](mailto:lib-ir@uiowa.edu).

## **THE DESIGN OF HAPTIC GAS PEDAL FEEDBACK TO SUPPORT ECO-DRIVING**

Hamish Jamson, Daryl L. Hibberd & Natasha Merat  
Institute for Transport Studies, University of Leeds, Leeds, U.K.  
Email: a.h.jamson@its.leeds.ac.uk

**Summary:** Previous literature suggests that haptic gas pedals can assist the driver in search of maximum fuel economy. This study investigated three haptic pedal designs, each with high and low intensities of feedback, in a rapid prototyping, paired comparison design. Twenty drivers took part, experiencing the systems in a high-fidelity driving simulator. Results suggested that drivers were best guided towards an “idealized” (most fuel efficient) gas pedal position by force feedback (where a driver feels a step change in gas pedal force) as opposed to stiffness feedback (where a driver feels a changing gas pedal firmness). In either case, high levels of force/stiffness feedback were preferred. Objective performance measures mirrored the subjective results. Whilst the short-term nature (brief system exposure) of this study led to difficulties in drawing longer-term conclusions, it would appear that force feedback haptics are better suited than stiffness feedback to augment an effective driver interface supporting “green” driving.

### **INTRODUCTION**

Minimizing fuel consumption has many advantages to the average motorist, including a reduction in the cost and environmental impact associated with a particular journey. Savings will continue to be made as vehicle and engine manufacturers continue to strive towards ever more efficient engines, however, even without complex powertrain modifications, significant gains can be made by modifying driver behavior. By advising a sample of motorists to optimize a drive profile through the elimination of unnecessary idling and adjusting acceleration rates and cruising speeds to ideal levels, Gonder et al. (2011) reported on-road fuel efficient improvements of between 30% and 60%. However, it is doubtful that such large numbers are sustainable in the long term as they tend to be observed only directly after training (af Wahlberg, 2002). Hence, the development of an on-board system to continuously support the driver in his/her continued search of optimum fuel efficiency seems logical. Several vehicle manufacturers are developing visual HMI which give continuous in-trip information to support an individual’s “green” driving, for example systems such as Honda’s *EcoAssist*, Ford’s *SmartGauge* or BMW’s *EcoPro*.

However, there is reason to suspect that continuous visual displays may cause undesirable side effects through distraction (see Regan et al., 2009, for a review). Alternative feedback modalities have great potential, in particular haptic feedback via the gas pedal, as arguably gas pedal position is the single most influential factor on excessive fuel consumption. By acting directly, at source, long-term economies may be achieved. Such is the theory behind Honda’s *EcoPedal*, which counteracts excessive pressure on the gas pedal by increasing the pedal’s resistive force.

A significant body of literature now exists to support the use of such haptic gas pedals. For example, Adell et al. (2008) conducted field trials of Intelligent Speed Adaptation in which forty private vehicles were equipped with two systems aimed at governing excessive speed: an active accelerator pedal (AAP) and non-haptic interface which warned via a short 3500Hz tone every

1.5s, accompanied by a flashing red dashboard light, when the speed limit was exceeded. Results show that both systems reduced the mean and 85<sup>th</sup> percentile speeds, but that the AAP was the more effective and greater preferred of the two systems. Similarly, Larsson & Ericsson (2009) found that a haptic gas pedal, installed on a fleet of four postal delivery vehicles, significantly reduced periods of high acceleration. Comparable simulator studies have also demonstrated that the benefits of haptic gas pedals over analogous visual dashboard systems include reduced driver workload (Birrell et al., 2010) and reduced emissions (Azzi et al., 2011).

However, few publications have investigated *how* the haptic interfaces are controlled in terms of their mechanical operation. The principal exception is Mulder (2007), who investigated haptic gas pedal feedback and design for the support of safer car-following on the proviso that the “design of a haptic gas-pedal feedback sensation has no real-life equivalent ... the process has largely been an heuristic process”. Mulder’s efforts culminated in a driving simulator study (Mulder et al, 2008) in which two conditions of haptic interface were trialed along with a baseline condition: *force feedback* and *stiffness feedback*.

Based on an algorithm that centered on time headway and inverse time-to-contact, the two haptic conditions provided increased gas pedal loading as, according to the haptic feedback logic algorithm, following conditions became more hazardous (see Mulder, 2007, for details on the implementation). In the *force feedback* condition (dashed line in Figure 1 left), the gas pedal spring stiffness remained constant, but an offset force was applied such that a greater pedal effort was required to maintain a particular gas pedal position. In the *stiffness feedback* condition (dashed line in Figure 1 right), the algorithm adjusted the pedal stiffness (gradient of the force/displacement graph) such that, although no immediate change in force could be felt, increased effort was required to depress the gas pedal.

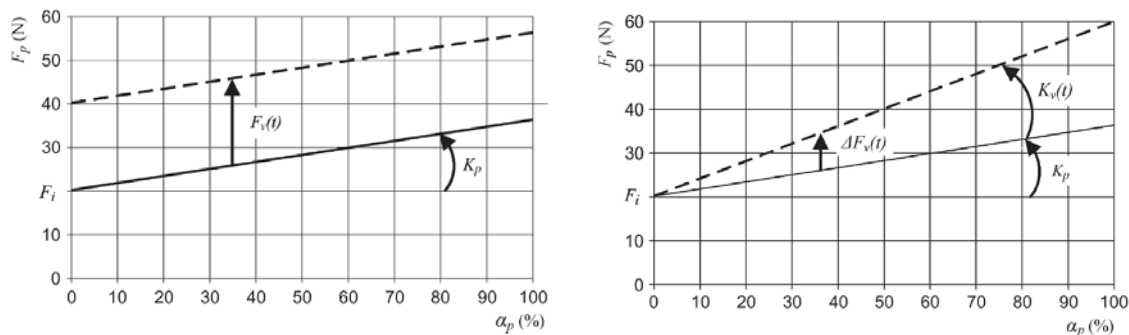

Figure 1. Gas pedal position-force profile for force (L) and stiffness (R) feedback (Mulder et al., 2011)

Results showed that, compared to baseline standard feedback (solid line in Figure 1), drivers adopt a force-task strategy when presented with haptic feedback, which leads to small improvements in car-following performance (less variation in time headway and inverse time-to-contact) through reduced pedal activity. Of the two interfaces, stiffness feedback was preferable in terms of reduced gas pedal activity, lowest variation in pedal force and increased headway.

This study was undertaken to evaluate which of Mulder’s designs is more appropriate to support the potential of haptic gas pedals to improve fuel-efficient, “eco-driving”. Given that stiffness changes were more well suited the management of following distance, it was hypothesized that a similar pedal feel would benefit the management of excessive acceleration.

## METHOD

### Apparatus

The study was performed using the University of Leeds Driving Simulator (Figure 2). The simulator cab was modified for this study to replace the existing gas pedal with a haptic gas pedal, such that up to eleven different profiles of pedal force and pedal travel can be predefined. The haptic gas pedal is physically linked to a servo motor mounted on the dynamic platform, on which the simulator cab is mounted. By controlling the motor torque and position via a Baldor Mint Drive, pedal feedback up to 200N can be commanded. The system bandwidth exceeds 15Hz.

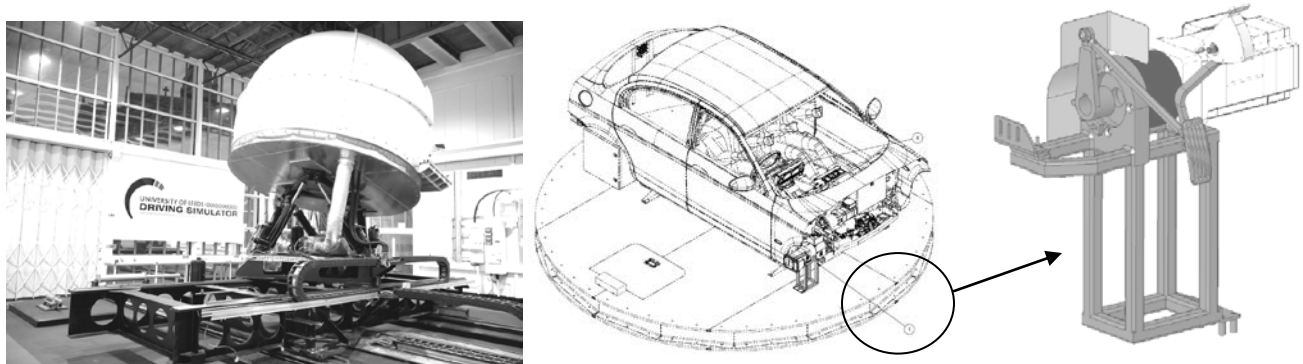

Figure 2. University of Leeds Driving Simulator with vehicle cab and haptic pedal design

### Experimental design

The experiment was devised in a paired comparison design so that several haptic feedback designs based on force and stiffness feedback could be evaluated against one another in a short time frame. The intention was undertake a form of rapid prototyping to evaluate which haptic designs merited further evaluation over a longer time frame in a subsequent study.

In a paired comparison, objects are presented in pairs to one or more judges, who are obliged to choose between the two based on pre-defined criteria. The technique is commonly employed when objects can only be compared in a highly subjective fashion. By summing the scores (the number of times an object is preferred over a competitor), the paired comparison allows a test of equality in order to assess the significance of any variation in those scores. The method is analogous to the F-statistic in ANOVA. The post-hoc test, which determines to what extent the levels of that factor differ from one another, is obtained from a Least Significance Difference of the overall rating scores. For a two-sided test at a particular significance level, a critical value ( $m_{crit}$ ) is calculated such that if the difference between total scores exceeds this value, the difference between those score can be proved at a particular confidence level:

$$m_{crit} = Z_{crit} \sqrt{(1/2)nt^2} + 1/2 \quad \text{where}$$

$Z_{crit}$  is the Z-score for the percentile point of the significance level in question

$n$  is the number of judges

$t$  is the number of repetitions of each paired comparison per judge multiplied by  $n$

## Driving scenario

The study was designed to investigate feedback style rather than algorithm design. Hence, the repeated driving scenario lasted for 30s and mimicked a concocted eco-driving algorithm guiding participants to an arbitrary “ideal” gas pedal position, which they were informed was the most appropriate manner to achieve maximum fuel economy for the given scenario. That scenario was a cruise>accelerate>cruise situation, involving leaving a built-up area (speed limit 40mph) into a rural area (speed limit 60mph). Each participant’s task was to achieve the “idealized” gas pedal positions of 7% in the initial 40mph cruise phase, increasing gas pedal travel to 23% for the intermediate acceleration phase, before returning to 7% for the subsequent 60mph cruise.

## Experimental conditions

Figure 3 shows the feedback conditions that were evaluated in the paired comparison. These totaled six: force feedback (low and high), stiffness feedback (low and high) and adaptive stiffness feedback (low and high); although not used in this study (except for familiarization, see Experimental Procedure) the long dashed line shows a standard (non-haptic) pedal.

In the force feedback condition, a significant extra force was required by the driver to further increase gas pedal travel beyond either 7% (when the haptic pedal was in the cruise profile) or 23% (when in the accelerate profile). For the low force condition, the step change in force was 20N, whilst in the high force condition that was doubled to 40N. The 7% or 23% “kneepoint” in each profile was designed to guide driver towards the idealized throttle angle.

In the stiffness feedback condition, the guide kneepoint was a distinct change in pedal stiffness, rather than a step force for drivers to overcome. For the low stiffness condition, the gradient changed from the standard stiffness of 0.2N per percent pedal travel to 1.45N per percent pedal travel, whereas this was doubled in the high stiffness condition to 2.9N per percent pedal travel.

The adaptive stiffness condition used the same profile gradient as stiffness feedback, however, it differed in its transition from cruise to accelerate profiles. This rationale was because whilst stiffness feedback gives a clear indication to remove pedal force through increased pedal load, it gives no indication of when to increase it. This is because at the 7% kneepoint, both profiles result in the same pedal position for the same pedal force.

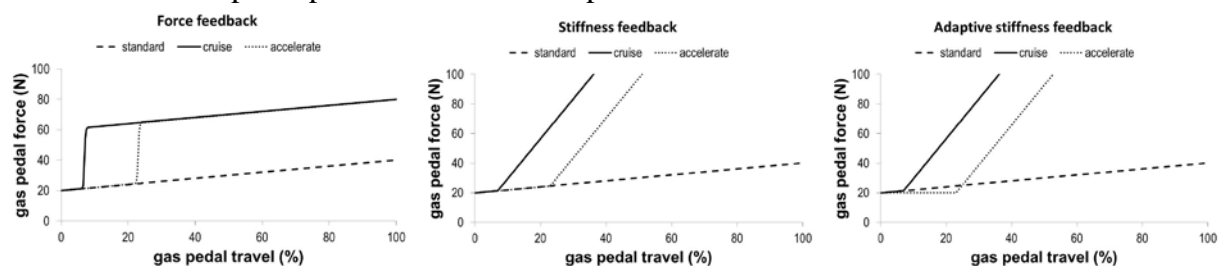

Figure 3. Haptic feedback conditions evaluated

## Experimental procedure

After arrival, briefing and informed consent, participants first underwent a familiarization of the scenario. The visual scene was faded to white, until the gas pedal was depressed. The scene then faded up with the participant travelling at 40mph in the urban section, but in full control of the

vehicle. After approximately 10s (cruise phase), participants passed a sign post indicating an increase in the speed limit from 40mph to 60mph. They then had 10s to accelerate from 40mph to 60mph, the appropriate time for this speed increase if they achieved the desired 23% gas pedal position for this accelerate phase. After a further 10s of cruise at 60mph, the visual scene faded back to white. Accompanied by a researcher, participants practiced this scenario on six occasions with standard (constant stiffness) pedal feedback. They then experienced each of the six experimental conditions twice in order to get a feel for how they differed. During this practice phase, they also had speed information displayed on simulator's speedometer.

After familiarization and a short break, participants re-entered the simulator alone to undergo the same scenario in which each of the six experimental conditions were presented in a paired comparison design. No speedometer advice was provided. Participants experienced the cruise>accelerate->cruise scenario with every combination of the haptic pedal conditions presented in pairs, before making a forced choice based on the question "of the two systems, which guided you best to the most appropriate gas pedal position". With six conditions, fifteen pairs were required for a fully balanced design. Order effects were managed by adjusting the presentation sequence according to a Galois field theory (Russell, 1980).

## Participants

20 drivers took part, well-balanced for gender (11♂, 9♀), age (mean 37.1♂, 36.6♀; s.d. 10.2♂, 7.4♀), driver experience (mean years licensed 17.7♂, 17.4♀; s.d. 11.0♂, 7.3♀) and annual mileage (8846♂, 9286♀; s.d. 2968♂, 1496♀).

## RESULTS

### Subjective data

The subjective preference data were reduced to the overall rating scores for each haptic pedal condition throughout the paired comparison (Figure 4). With 20 participants and each system experienced on five occasions (each compared against with its competitors), the maximum score for each condition was 100. Subjective preference data were analyzed according to a non-parametric test of equality. At the 95% confidence level, the Least Significance

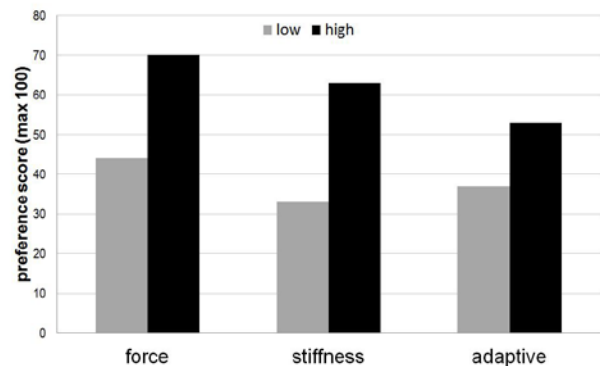

Figure 4. Subjective preference ratings

Difference method suggests that a significant difference between condition scores occurs when the critical score difference ( $m_{crit}$ ) is 15. Figure 4 shows the clear disposition towards the high feedback systems over their weaker strength (low) counterparts. However, the difference between the feedback systems was not so clear. Whilst high force feedback achieved significance in its popularity from adaptive stiffness, this was not quite demonstrated for stiffness feedback. Similarly, low force, low stiffness and low adaptive stiffness did not differ significantly.

## Objective data

Whilst several objective data were recorded, space limits permit the reporting of one: *root mean squared pedal error*, indicating to what extent participants managed achieve the idealized gas pedal position throughout the 30s of scenario. These data are shown in Figure 5 and were analyzed using a one-way, repeated-measures ANOVA with the six levels of System corresponding to the six haptic pedal conditions. The assumptions of ANOVA were not violated.

There was a strong main effect of System;  $F_{(5,95)}=15.7$ ,  $p<.001$ ,  $\eta^2=.48$ . Least Squared Difference post-hoc tests suggest several significant pairwise differences. Of the low conditions, force feedback proved to be significantly better at achieving the “ideal” gas pedal position target (lowest root mean squared pedal position error) than both low stiffness feedback ( $p=.020$ ) and low adaptive stiffness feedback ( $p=.027$ ).

The story was similar for the high conditions, where force feedback again proved more successful than stiffness feedback ( $p=.030$ ). However, the difference between force and adaptive stiffness feedback was not proven ( $p=.176$ ). In both cases, the varying stiffness feedbacks did not differ measurably (low:  $p=.95$ ; high:  $p=.48$ ).

For a particular type of system, high feedback intensities achieved significantly better compliance of “ideal” gas pedal position than corresponding low feedback (force:  $p<.001$ ; stiffness:  $p<.001$ ; adaptive:  $p=.001$ ).

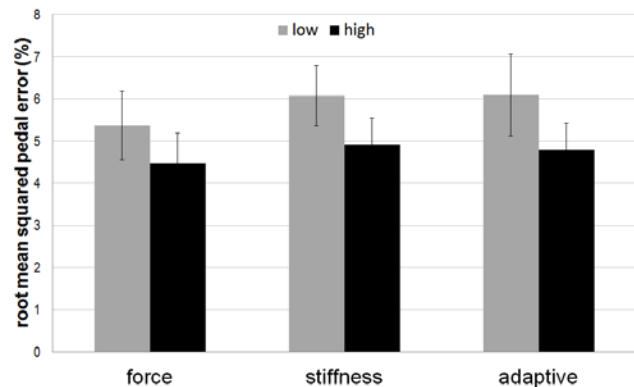

Figure 5. Objective performance (errors bars show 95% CIs)

## DISCUSSION

In terms of subjective ratings, results showed that force feedback was preferred to adaptive stiffness feedback. This appears to be at odds with Mulder et al. (2008), however, this may have been due to nature of the haptic pedal being required to achieve two quite different tasks: in this study to achieve a target gas pedal position, whilst in Mulder’s case to prevent unsafe following.

The main objective of this study was to evaluate preliminary designs to support “green” driving. In practice, the in-trip guidance provided by such a haptic system would occur over far longer durations than the short 30s scenario utilized here, hence this study provides little in terms of an assessment of long term driver comfort. In a real system, should advice need to be overridden, especially in the preferred high force condition, applying such high pedal forces may well lead to fatigue from the need to co-contract both the shin muscles and calf muscles to stabilize the desired gas pedal position, resulting in undesirable physical driver workload (Abbink, 2006).

It is promising that the objective measures of task performance support the subjective preferences in terms of a greater intensities of feedback being more successful, as well as more popular, in achieving the eco-driving task. To some degree, the contrived nature of the task may have lent itself toward more forceful feedback, supporting the cruise>accelerate>cruise task

simply by lack of subtlety. However, that the magnitude of the errors between low and high feedbacks was not large (some 1% of throttle travel), which in reality would account for marginal differences in actual fuel consumption, this study adds further evidence that, in general, haptic feedback is well capable of providing suitable eco-driving support. Further research is planned to evaluate the effects of such varying designs of haptic support over longer time frames to include the evaluations of issues such as acceptance, workload and physical distraction.

## ACKNOWLEDGMENTS

This work was undertaken as part of the EU project *ecoDriver* ("Supporting the driver in conserving energy and reducing emissions") funded under the Framework Seven (FP7) Information and Communication Technologies (ICT) work programme, project number 288611.

## REFERENCES

- Abbink, D.A., 2006. Neuromuscular analysis of haptic gas pedal feedback during car following. PhD thesis, Technical University of Delft.
- Adell, E., Várhelyi, A. & Hjälmdahl, M. (2008). Speed management – a comparative real life study. *Transportation Research Part F*, 11(6), 445-458.
- Azzi, S., Reymond, G., Mérienne, G. & Kemeny, A. (2011). Eco-driving performance assessment with in-car visual and haptic feedback assistance. *Journal of Computing and Information Science in Engineering*, 11, 041005 1-5.
- Birrell, S.A., Young, M.S. & Weldon, A.M. (2010). Delivering smart driving feedback through a haptic pedal. In: *Contemporary Ergonomics and Human Factors*, 431-439, Ed.: Anderson, M., Taylor & Francis, London.
- Gonder, J., Earleywine, M. & Sparks, W. (2011). Fuel saving effectiveness of various driver feedback approaches. Final Report NREL/MP-5400-50836, National Renewable Energy Laboratory, U.S. Department of Energy Office of Scientific and Technical Information.
- Larsson, H. & Ericsson, E. (2009). The effects of an acceleration advisory tool in vehicles for reduced fuel consumption and emissions. *Transportation Research Part D*, 14(2), 141-146.
- Mulder, M. (2007). Haptic gas pedal feedback for active car-following support. PhD thesis, Technical University of Delft.
- Mulder, M., Mulder, M., van Paassen, M.M. & Abbink, D.A. (2008). Haptic gas pedal feedback. *Ergonomics*, 51(11), 1710-1720.
- Mulder, M., Abbink, D.A., van Paassen, M.M. & Mulder, M. (2011). Design of a haptic gas pedal for active car-following support. *IEEE Transactions on Intelligent Transportation Systems*, 12(1), 268-279.
- Regan, M.A., Lee, J.D. & Young, K.L., eds. (2009). *Driver distraction: theory, effects, and mitigation*. CRC Press, Boca Raton, Florida.
- Russell, K.G. (1980). Balancing carry-over effects in round robin tournaments. *Biometrika*, 67(1), 127-131.
- af Wahlberg, A.E. (2002). Fuel efficient driving training: state of the art and quantification of effects. *Safety On Roads International Conference*, 21<sup>st</sup> – 23<sup>rd</sup> October 2002, Bahrain.