

1990

Life Science For Elementary Teachers

Catherine Devine
University of North Florida

Suggested Citation

Devine, Catherine, "Life Science For Elementary Teachers" (1990). *UNF Graduate Theses and Dissertations*. 169.
<https://digitalcommons.unf.edu/etd/169>

This Master's Thesis is brought to you for free and open access by the Student Scholarship at UNF Digital Commons. It has been accepted for inclusion in UNF Graduate Theses and Dissertations by an authorized administrator of UNF Digital Commons. For more information, please contact [Digital Projects](#).

© 1990 All Rights Reserved

LIFE SCIENCE FOR ELEMENTARY TEACHERS

by

Catherine Devine

A project submitted to the Department of Education in
partial fulfillment of the requirements for the degree of
Master of Science in Education

UNIVERSITY OF NORTH FLORIDA

COLLEGE OF EDUCATION

December, 1990

The thesis of Catherine Devine is approved:

(Date)

Signature Deleted

12/14/90

Signature Deleted

12/30/90

Signature Deleted

1/24/91

Committee Chairperson

Accepted for the Department:

Signature Deleted

1-24-91

Chairperson

Accepted for the College/School:

Dean/Director

Accepted for the University:

Vice-President for Academic Affairs

Table of Contents

	Page
List of Tables and Figures.....	iv
Abstract.....	vi
Chapter One - Introduction.....	8
Chapter Two - Review of Literature.....	12
Chapter Three - Procedures.....	21
Chapter Four - Life Science for Elementary Teachers....	24
List of Activities.....	27
Results and Conclusions.....	172
References.....	177

Tables and Figures

TABLES

- Table A: Measurement of Bones
- Table B: Record of Bean Measurements
- Table C: Record of Measurements to Determine Volume
- Table D: Record of Numbers of Toothpicks
- Table E: Record of Observations
- Table F: Morningness/Eveningness Distribution
- Table G: Class Range of Morningness/Eveningness Scores
- Table H: Observation of Carrots in Water
- Table I: Temperatures of Prepared Bags
- Table J: Effects of Pulling Foot Model Strings
- Table K: The Effect of Certain Variables on Balance
- Table L: The Effects of Eyes and Ears on Balance
- Table M: Characteristics of Soil
- Table N: Plants in the Square-Meter Community
- Table O: Animals in the Square-Meter Community
- Table P: Change in Water Levels
- Table Q: Seeds Sprouting
- Table R: Pollution Collected

FIGURES

- Figure 1: Leaf Arrangements of Conifers
- Figure 2: Hand and Foot Bones
- Figure 3: Bean Between Blocks for Measurement
- Figure 4: Plants in Boxes
- Figure 5: Potato in Beaker
- Figure 6: Beans Between Glass Slides
- Figure 7: Geranium Plant with Covered Leaf
- Figure 8: Arrangement of "Cider Mill"
- Figure 9: Carrot with String
- Figure 10: Circles for Heart Models
- Figure 11: Two Chambered Heart Model
- Figure 12: Three Chambered Heart Model
- Figure 13: Four Chambered Heart Model
- Figure 14: Foot Model Pieces
- Figure 15: Assembly of Foot Model
- Figure 16: Arm Model Pieces
- Figure 17: Arm Model Assembly
- Figure 18: Assembly of Dishpan and Water
- Figure 19: Pollution Strip

Abstract

Science is taught at all grade levels, yet there exists a deficiency in the amount of emphasis placed on science training for elementary teachers. As a result, teachers often feel inadequate in their knowledge of scientific areas and in their ability to develop science process skills in their students. As a result in this lack of training, a need exists to provide programs to increase skill and confidence of elementary teachers not only in teaching science concepts but science process skills as well.

One means of meeting this need was the development of an activity-based, process-oriented inservice curriculum designed specifically for elementary science. The curriculum was designed as an inservice component of 60 hours that emphasized process skills as well as updating science concepts. The curriculum was designed for use in grades 1-6 and stressed "hands-on" experiences using readily available materials and a minimum of specialized equipment.

The curriculum was field tested as a component of the Clay County, Florida Summer Inservice Institute. Thirty eight teachers, whose teaching assignments ranged from kindergarten to sixth grade, participated in the field test.

At the beginning of the Institute, no participant scored 80% or better on a pretest of knowledge of concepts

and process skills. Each participant completed each activity in the role of a student, including forming a hypothesis, collecting data, and drawing a conclusion. Activities were then discussed stressing process skills used and an indepth review of concepts involved. On the final day of the Institute, 84% of the participants scored 80% or better on the posttest. Furthermore, evaluations of the component by participants indicated a marked improvement in confidence in and enthusiasm for teaching science process skills. Overall the curriculum met the objective of increasing elementary teachers' ability and willingness to teach science process skills as well as science concepts.

Chapter One

Introduction

Science is taught at all grade levels from 1-12, yet there exists a common deficiency in the amount of emphasis placed on science training for elementary teachers. Consequently, these teachers often feel inadequate in their knowledge of scientific areas. In addition to lack of specific content knowledge, they may also need training to develop science process skills of students and may lack access to ideas and materials available to teach these process skills. As a result, elementary level science lessons often degenerate into paper-pencil reading skills, two-dimensional pictures or filmstrips. Too few elementary classrooms generate enthusiasm for science or creative thinking in their students. Elementary teachers find themselves dreading science lessons or overlooking daily opportunities to encourage "scientific" thought processes.

As students enter the secondary grades, two characteristics are evident in their scientific attitude. First, they perceive science as difficult and only designed for a select few who possess "scientific" minds. Secondly, they believe that science proceeds deductively and passively. These attitudes hinder the development of sound, yet innovative thinking on the part of the students.

As students enter adolescence they lose spontaneity and the keen interest in their physical environment, two characteristics necessary for scientific learning. At a developmental stage characterized by its need for conformity, the science curriculum is beginning to increasingly demand flexible and creative thinking. By high school age many students are prejudiced against science and view it as complex, dull and unfathomable by the average person. Lack of early stimulating and successful experiences that encourage each and every student to be "scientific" has produced fearful, rigid students.

Students' lack of scientific process skills such as classification, prediction, and inference hampers the teaching of more sophisticated concepts and renders laboratory experiences bewildering and pointless. At a time when curriculum and teacher expectations demand attention to concepts and analysis of information, students are still struggling to exercise such basic skills as observation, identification of variables and the formation of hypotheses.

Clearly, the mastery of basic science skills at the elementary level would enhance learning in secondary science and would enable concentration on higher-level skills.

Since the development of creative, flexible thinking in science, coupled with familiarity and confidence in scientific processing of information is a goal for students, teachers need training which will help them nurture these

skills in their students. The training could be in the form of team teaching, workshops or inservice.

Teachers need experiences that will improve their knowledge of content, their understanding of process skills, and their awareness of opportunities to apply these skills. They need training that will motivate them and immerse them in "hands-on" experiences that they can apply with even the youngest students.

Skill and confidence in developing and facilitating science lessons by elementary teachers could be enhanced in many ways. Certainly inservice training through extended workshops would provide opportunities for upgrading knowledge. A program of team teaching and availability of a mobile science resource unit staffed by an experienced science teacher and housing equipment and materials for experiments would also help meet the need.

In the Clay County, Florida, School District, one existing program that could be modified readily to serve this purpose is the Summer Inservice Institute. Components could be developed specifically to enhance elementary programs. Components might be organized around the traditional fields of science, namely biology, physical science and earth science, or they might be arranged to encompass a cluster of grade levels. Each of these components could be designed to broaden knowledge of both content and process skills. Four areas that might be addressed include: (a) the development of content to review

and update teachers' knowledge in the field, (b) laboratory experiences to give teachers practice and confidence in using science process skills, (c) techniques and materials for developing science process skills in elementary-age students and, (d) resources for purchasing materials and plans for investigative experiences appropriate to elementary-age students.

The purpose of this project is to develop a component suitable for the Clay County School District Summer Inservice Institute that would meet the need to increase elementary teachers' confidence and skill in providing experiences that teach science process skills as well as science knowledge to elementary students.

Chapter Two

Review of Literature

Before curriculum can be developed for elementary teacher science training two areas should be explored. First, there should be established a clear-cut description of the need that exists and the parameters of this need. The second concern is the development of the curriculum. Examination of previous and current programs will provide direction regarding possible objectives and expected outcomes of any curriculum developed.

Many observers and experts agree that the majority of elementary teachers are uncomfortable teaching science and therefore spend less time teaching science than mathematics and language arts (Duschl, 1983; Hounshell, 1987; Yager and Yager, 1985). For example, in questioning appropriately 500 elementary teachers, Hounshell (1987) found that most elementary teachers not only did not enjoy teaching science but did not enjoy studying it either.

Similarly, a comparative study (Gates, Krockover, & Wiedermann, 1987) of science student teaching practices at three geographically diverse universities found a decline of 13% in the number of elementary classrooms in which science was taught from years 1978-79 to 1985-86. The decline from years 1971-72 to 1985-86 was an even more dramatic 25%. In

the same comparison, teachers teaching science by inquiry decreased from 62% of teachers surveyed in 1971-72 to 13% in 1985-86. Reasons given for not teaching science or reducing the amount of science instruction included: (a) teachers did not perceive themselves as having enough science background; (b) teachers did not like science; (c) science is scheduled differently from other subjects; (d) classrooms have few appropriate materials; and (e) teachers note the inability of students to read science.

Clearly a relationship exists between the confidence a teacher feels in his/her abilities to teach a subject and the amount of time devoted to teaching that subject. For example, a national survey reported 63% of elementary teachers felt well qualified to teach reading and therefore spend an average of 105 minutes daily on reading activities. In the same survey only 22% of these teachers felt qualified to teach science, which resulted in a mere 18 minutes assigned daily to science activities (Gerlovich, Downs, & Magrane, 1981).

While it is widely acknowledged that elementary teachers do not enjoy the teaching of science, the opinions as to why this dislike exists and how to remedy this problem vary. One factor is the fact that most elementary teachers have limited preservice training in the sciences. The typical elementary teacher obtains 6-11 semester hours in general science content courses (Hounshell, 1987) in addition to science methodology courses. Many student

teachers feel their content and methods courses give them inadequate preparation (Gates et al., 1987). In addition less than 20% of educational programs require elementary students to complete science courses in all three of the major science areas, namely physical, earth and biological sciences; such a situation leaves them with no content knowledge in at least one and perhaps two content areas (National Science Teachers Association (NSTA), 1982).

Content courses for most non-science majors consists of survey classes that emphasize a body of knowledge and do nothing to engage the preservice teacher in the scientific process (Dykstra, 1987). Approximately two-thirds of preservice institution programs make no distinction between content courses for education majors and courses for science majors, which leaves the preservice teacher seeing little or no relationship between content and methods of instruction (NSTA, 1982). Students who are most successful in such content courses often have a good grasp of information but have no experience with the process of obtaining information (Yager & Yager, 1985). There is little focus upon the tentative nature of scientific knowledge or the use of scientific knowledge. Methodology courses, on the other hand, stress science as a process; therefore, a paradox between science as a product and science as a process emerges in the preservice teachers' experience (Duschl, 1983). This paradox leads to apprehension on the teachers' part and causes a fear of teaching and learning science.

Means for alleviating this apprehension and creating interest and enthusiasm for teaching science among elementary teachers are not universally agreed upon. For example, Duschl (1983) suggests changing the sequence of training so that methodology is taught before content. He also suggests that education faculty should teach the content courses to enhance interaction between teaching process and information. In direct contrast, other studies believe that it is essential for the preservice teacher to gain fundamental knowledge of science before acquiring strategies for teaching (NSTA, 1982). It is also suggested that content courses be designed specifically to meet the needs of education majors by increasing the emphasis on and the awareness of applications to classroom situations and process skills used.

One point that recurs in studies of teacher education is the need for practice in using scientific information and process. Studies indicate that competency in teaching process skills can be improved by use of hands-on activities and self-instructional science process materials (Strawitz & Malone, 1987). Improving teacher competency in process skills, in turn, results in increased teaching practices that use process skills. Results of studies indicate that teachers who feel secure in teaching process skills prepare and teach lessons containing process skills (Zeitler, 1981). Field experiences in the classroom are also recommended (NSTA, 1982).

Not surprisingly, elementary teachers themselves express a need to be more knowledgeable about specific strategies for teaching science. This knowledge, they feel, will help reduce their fear of science and lead to better science teaching. Elementary teachers voice a desire for training that is relevant to elementary needs, shows application of science to daily life, and stresses process as well as content. In addition, teachers recommend acquiring knowledge about sources of classroom materials, more knowledge about relating science to other disciplines, and continuing inservice opportunities (Yager, 1980). In general, teachers feel less need to become experts in science; their training should deal with the development of scientific ideas, new teaching methods, and using manipulative or hands-on materials (Horn & James, 1981).

While there are many approaches to solving the problems perceived by elementary teachers, one approach to improving teacher confidence and skill is through the implementation of inservice education experiences. In a survey of science educators by Gallagher and Yager (1981), 25% of the respondents cited inappropriate inservice opportunities as a major problem in science education. This report indicated a need for continuing education programs to prevent a further decline in science education. Specific recommendations by teachers for inservice education include: (a) use of short-term workshop format; (b) utilization of local, easily accessible training centers; (c) providing focus on science

teaching methods as well as content materials; and (d) activity-oriented programs coordinated with up-to-date materials and curriculum (Burke, 1980).

Increasingly, teachers feel the need to improve their understanding of and proficiency with science process skills (Riley, 1979). While the majority of teachers feel they need no assistance in planning or actually teaching lessons, most felt a need in implementing discovery/inquiry experiences and using manipulative materials. As pointed out by Campbell and Okey (1977), there has been an emphasis on student mastery of skills as compared to mastery of facts. Many federally funded science curricula emphasize process skills, and elementary teachers therefore feel a strong need for confidence in using these skills. Furthermore, studies have found that teachers trained in competency in process skills use these skills more often in their lessons than teachers with no training (Jaus, 1975; Zeitler, 1981).

The goal of inservice training, therefore, must clearly be to influence teacher competency and confidence in the use of process skills. In a study by Spooner, Szabo and Simpson (1982), significant changes in teacher attitudes toward not only science but teaching science were positively influenced in a five day workshop. This finding supports the belief that teachers can be influenced positively with short-term inservice training. This change in attitudes toward use and knowledge of process skills can be influenced with training

experiences of relatively short duration; thus inservice training is a viable method to increase teachers' use of process skills.

Providing appropriate inservice education can convince elementary teachers that process skills, rather than the acquisition of knowledge, are an integral part of their teaching (Neuman, 1981). Jaus (1975) found that teachers trained in process skills voluntarily wrote significantly more objectives designed to teach process skills and used more process skill activities than do untrained teachers. Likewise, Bluhm's (1979) study found that preservice teachers showed significant improvement in their skills in using scientific problem-solving when exposed to activity-based instruction that allows them to design and complete experiments.

Varied approaches to inservice experiences have proved effective in changing teachers' attitudes toward teaching science. Brown (1977) found that preservice teachers gained competency in the use of process skills when allowed to complete fourteen laboratory exercises in an open laboratory setting. Teachers were supplied directions based on "Science-- A Process Approach" and were allowed to work at their own pace. Advantages to such an approach include, (a) allowing the instructor and student to interact on a one-to-one basis, and (b) making possible the use of fewer sets of materials with large numbers of students.

Another approach to inservice training well received and successful used mini-courses requiring three sessions of five hours duration each (Dyche, 1980). While content was emphasized, the courses included laboratory activities and practice with science process skills. Over 65% of participants of these mini-courses indicated plans to increase the amount of time spent in teaching science while 81% of participants indicated they would alter their method of teaching science, specifically mentioning more hands-on activities.

A third approach to inservice training is the use of a televised program (Sheldon & Halverson, 1981). In a televised series of inservice programs, 73% of participants indicated these programs had been an effective method of altering their understanding of concepts and teaching strategies. One major suggestion to encourage success is the use of locally produced programs rather than professionally produced programs, since local programs provide greater individualization. Advantages of a televised program of inservice education include elimination of teachers' travel time and expense and opportunities for teachers to view materials several times and at later dates.

Regardless of format used to present inservice opportunities, successful programs have some characteristics in common. Effective programs should (a) have a specific goal or focus; (b) provide opportunities for laboratory, hands-on activities, (c) teach participants how to use

knowledge rather than simply obtain knowledge, and (d) provide experiences that are practical and related to participants' needs (Mehling & Oliver, 1983).

Clearly, research indicates a need for enhancement of elementary teachers' attitudes about the teaching of science. Teachers feel the need for more education in teaching strategies and science process skills. While many approaches to solving this problem are available, one approach, namely that of inservice programs, has proved effective. Previous Summer Inservice Institutes in Clay County School District have had good teacher participation indicating that this format is accepted by many teachers. Inservice offerings are also cost effective for a small yet growing school district. Use of short-term process-oriented programs has been shown to be effective in both improving teachers' attitudes toward science and increasing their confidence in using process skills. Therefore, development of a Summer Institute Curriculum for Elementary Science Teachers can be a viable solution for a persisting problem of teacher apprehension toward science and the consequent reduction of time spent in teaching science.

Chapter Three

Procedures

The curriculum developed in this project was designed to meet the needs of elementary teachers, grades 1-5, in Clay County, Florida, school system. The curriculum was developed as an inservice component of 60 hours in the Clay County Summer Inservice Institute. The curriculum is an activity-oriented program and designed to upgrade both content knowledge and science process skills.

As shown by several studies, elementary teachers have expressed a strong desire to receive help in planning activity-oriented science lessons. The literature indicates a need for inservice programs that increase competency in process skills and provide practical experiences that generate enthusiasm for teaching science.

Work with elementary teachers in previous Clay County Summer Inservice Institutes has revealed that these needs also exist at the local level. These teachers have shown enthusiasm and willingness to work diligently in programs to enhance their science teaching skills. Evaluations of previous Summer Institute programs in Clay County suggest a need exists to provide a curriculum exclusively for elementary teachers. This curriculum should emphasize

practice with science activities as well as update of science concepts.

Objectives are relevant to existing life science curricular programs in use in the Clay County Schools, grades 1-5. Teachers will practice and develop activities to accompany and enrich the current curriculum. Objectives relating to process skills are taken from the Minimum Student Performance Standards for Florida Schools, grades 3-5. Also included in process skills are objectives from the Student Performance Standards of Excellence for Florida Schools in Science, grades 3-5.

Content was selected according to two primary criteria. First, activities and content knowledge were relevant to the existing science curriculum and easily adapted to use in the non-specialized classroom. Activities used readily available materials and a minimum of specialized equipment. Secondly, content activities must emphasize science as a process and provided opportunities to develop and strengthen elementary science process skills. As pointed out by several studies of perceived needs of elementary teachers, process skills are an area in which many teachers feel inadequately prepared. Additionally, need for education in process skills is emphasized by the fact that many objectives set forth by the Minimum Student Performance Standards for Florida Schools and the Student Performance Standards for Excellence for Florida Schools are process-oriented rather than content oriented.

Evaluation of this curriculum occurred through peer review by Clay County elementary teachers and curriculum specialists.

Chapter Four

Life Science for Elementary Teachers

This component is designed to update and expand knowledge of life science concepts taught in grades 1-6 and to provide experience in using activities to develop science process skills.

Objectives: Upon completion of the Life Science component of the Summer Inservice Institute participants will be able to meet the following objectives:

1. make and record observations, qualitative or quantitative, in a systematic and appropriate way about an object, substance or event.
2. select appropriate SI units and measuring instruments to perform simple measurement of length, volume, mass and temperature of a given object or substance.
3. given a set of objects, classify these objects according to similarities and differences and identify the properties on which classification is based.
4. demonstrate ability to read and interpret information from charts, graphs, and tables.
5. draw inferences from a set of observations.

6. interpret cause and effect relationships within a problem solving situation.

7. form hypotheses and distinguish between observations that support the hypothesis and those that do not.

8. distinguish between relevant and irrelevant information related to a problem solving situation.

9. describe a sequence of events occurring in an activity or problem solving situation.

10. distinguish among observation, inference and prediction.

11. construct predictions based on previous observations and construct tests for these predictions.

12. identify conditions that cause or influence a change in an object or system.

13. be able to classify things as living or non-living, using observable characteristics.

14. be able to classify living things as plant or animals, using observable characteristics.

15. predict conditions needed for and describe stages of plant growth.

16. classify parts of a simple green plant and give their function.

17. distinguish between invertebrates and vertebrates.

18. classify common vertebrate animals into appropriate groups based on observable characteristics.

19. identify conditions needed for a plant or animal's survival and growth.

20. contrast ways in which plants and animals obtain energy.

21. describe various types of plant and animal reproduction and development.

22. identify abiotic and biotic factors in an organism's environment and the relationship of these factors to the organism's survival.

23. identify major types of habitats and their characteristics.

24. identify factors that may change in a habitat.

25. describe the relationship of organisms within a food chain or food web.

26. describe how man's interruption has affected the environment, plants, animals, and their interdependence.

27. identify major biomes and their characteristics.

28. describe physical and behavioral adaptations that allow plants and animals to adapt successfully to their environment.

29. describe the relationship between habitat, population, community and ecosystem.

30. identify and give characteristics of common bacteria, protists, and fungi.

List of Activities

	Page
Activity #1 Making Observations - What's Different	29
Activity #2 Making Observations	31
Activity #3 Taxonomic Key for Shoes	33
Activity #4 How Can Trees Be Identified?	36
Activity #5 Using International System of Units	42
Activity #6 Using Metric Measurements and Organizing Data	46
Activity #7 How Does An Organism's Color Affect Its Survival?	52
Activity #8 Using the Scientific Method to Solve a Problem	55
Activity #9 Solving a Problem with the Scientific Method	59
Activity #10 Testing Different Antiseptics	63
Activity #11 Circadian Rhythms	65
Activity #12 How Do Plants Respond to Light?	80
Activity #13 Do Plants Need Soil to Grow?	83
Activity #14 How Does Water Get Into a Plant?	86
Activity #15 How Do Roots and Stems Grow?	88
Activity #16 How Does A Plant Grow Taller?	91
Activity #17 Testing for Starch in Plant Leaves	93
Activity #18 Do Plants Need Light to Make Food?	96

	Page
Activity #19 How Are Seeds Adapted for Dispersal?	99
Activity #20 Does Yeast Make A Gas As It Grows?	101
Activity #21 Fermentation and Apple Cider	104
Activity #22 Diffusion	107
Activity #23 Osmosis in Eggs	110
Activity #24 Making a Cell Model	113
Activity #25 How Do Insects Develop?	115
Activity #26 What Do the Hearts of Different Animals Look Like?	118
Activity #27 Keeping Warm With a Coat of Down	125
Activity #28 Removing Minerals From Bones	128
Activity #29 How Does the Foot Move?	130
Activity #30 How Does an Arm Move?	134
Activity #31 How Do Our Senses Help Balance Our Body?	139
Activity #32 Biological Communities	143
Activity #33 Life in a Square Meter Community	147
Activity #34 Different Water Environments	152
Activity #35 Using Solar Energy to Clean Water	155
Activity #36 How Do Decomposers Decay Organisms?	159
Activity #37 How Do Oil Spills Affect the Environment?	161
Activity #38 How Does Pollution Affect Seeds?	164
Activity #39 How Do Pollutants Change Water?	167
Activity #40 Detecting Air Pollution	169

Activity #1 Making Observations -- What's Different?

OBJECTIVE: To use a variety of senses to detect changes in an object or subject

SCIENCE PROCESS SKILLS: observation

SCIENCE CONCEPTS: none

MATERIALS: perfume, bell, scarf, glasses, personal accessories

PREPARATION TIME: 10 minutes

TEACHER PROCEDURE:

1. Have each student walk in front of group for observation. Tell students to observe carefully.
2. Have each student go to a separate, unobserved area such as a hall. Each person should add or remove an object to alter their appearance, ie. putting on glasses, placing a bell or rattle in their pocket, or putting on perfume.
3. Have each student walk in front of the group. Call on individuals to tell what has changed in appearance. What differences do you notice in the individual? (Answers will vary). What senses did you use to make your observations? (sight, smell, hearing, etc).

TEACHER DISCUSSION: Observation is the simplest yet most essential skill to scientific methods. Observation should use as many senses as possible. Stress the importance of careful observation. Discuss what senses were used and

possible use of additional senses. Use of recorded data (written) as compared to unrecorded observations should be discussed.

(Shymansky, Romance, & Yore, 1988, Level 1, p.3)

Activity #2 Making Observations

OBJECTIVE: To increase the use of senses to make thorough observations

SCIENCE PROCESS SKILLS: observation, making scientific drawings, recording observations

SCIENCE CONCEPTS: none

MATERIALS: leaves, starfish (preserved), seashells, flowers

PREPARATION TIME: 15 minutes

TEACHER PROCEDURE:

1. Give each student an envelope or container with an objective. Allow 10 seconds for first and second observation. Give no additional directions.

STUDENT PROCEDURE:

1. Observe the specimen for 10 seconds then return it to the container. Record as many details as possible about your specimen.

2. Observe your specimen again for an additional 10 seconds, again returning it to the container after the observation. Use senses other than sight to observe. Record your additional observations.

3. Now, without further observations, make a drawing of your specimen. Provide as much detail as possible.

4. While observing your specimen again, add additional details to your drawing. What other instruments would help you make observations about your specimen?

TEACHER DISCUSSION: Stress use of senses in observation and careful recording of observations. Ask students to analyze their method of observation. Ask students what instruments they would like to use to increase their powers of observation. (Possible answers include hand lens, microscope.) The role of instruments in scientific observation can be discussed, for example, would a microscope have made the observations more accurate. (Creager, Jantzen, & Mariner, 1985, p.7)

Activity #3 Taxonomic Key for Shoes

OBJECTIVE: To introduce students to the development and use of a dichotomous key

SCIENCE PROCESS SKILLS: observation, classification

SCIENCE CONTENT: none

MATERIALS: students' shoes

PREPARATION TIME: 5 minutes

TEACHER PROCEDURE:

1. As students enter the class, tell them to remove their right shoe. Place all shoes on the table in front of students.

2. Ask students to provide a characteristic that will divide the shoes into two groups (e.g., shoelaces; no shoelaces). Be sure that characteristic suggested will divide all shoes into only two distinct groups. Write the category on the board. Be sure all shoes fit into one or the other category.

EXAMPLE: Taxonomic Key

1A has shoelaces	go to 2A
1B no shoelaces	to be filled in later

Divide shoes according to first characteristic and work with that group only. Ask for another characteristic to divide the group into two groups.

2A brown color	go to 3A
2B not brown color	to be filled in later

Again divide the brown shoes with shoelaces from other shoes. Ask for another characteristic.

3A size 6	Sue's shoe
3B not size 6	go to 4A

Keep dividing until one shoe is identified. Continue with next characteristic.

4A has rubber sole	Tom's shoe
4B does not have rubber sole	Paul's shoe

When all shoes in the first group have been identified, return to the last blank in the key (shoes not brown in color) and insert the appropriate number. (In this case, 2B not brown color go to 5A). Continue with characteristics for this group.

5A has 3 pair eyelets or less	go to 6A
5B has more than 3 pair eyelets	to be filled in later

Continue until all shoes have been claimed. To test key, have a student hold up his/her shoe and classify it starting from 1A.

TEACHER DISCUSSION:

A DICHOTOMOUS KEY is a binary classification system in which a set of objects is divided into two subsets on the basis of whether each object does or does not have a particular property. To construct a dichotomous key you must first identify a property which some of the objects have but all the others do not have. When constructing the key be certain that all the objects in the original set will fit into one and only one of the two subsets. Discuss other common materials that could be used for this exercise such as fruits, vegetables. Discuss uses of dichotomous keys in science to identify organisms or classify organisms.

(Wright, 1982, p. 34)

Activity #4 How Can Trees Be Identified?

OBJECTIVE: To gain experience in using a dichotomous key

SCIENCE PROCESS SKILLS: observation, classification

SCIENCE CONCEPTS: characteristics of tracheophytes, classes of tracheophytes, characteristics and examples of gymnosperms, taxonomy

MATERIALS: branches of various pine trees, bald cypress, cedar, juniper, hand lens, metric ruler

PREPARATION TIME: 30 minutes

TEACHER PROCEDURE :

1. Provide students with as many different samples of conifer branches as possible.
2. Tell students to carefully observe branches and given the key, try to identify each branch. You may need to go step by step with students through the key.
3. Record the features of each branch. Use diagrams to help you.
4. Use the key to determine the name of the tree from which the branch was taken.

STUDENT PROCEDURE:

1. Examine each branch carefully. You may need to use the hand lens.
2. Record the features of each branch such as needle arrangement. Use the diagrams in Figure 1 to help you.

3. Use the key provided to determine the name of the tree from which the branch was taken.

Figure 1: Leaf Arrangements of Conifers

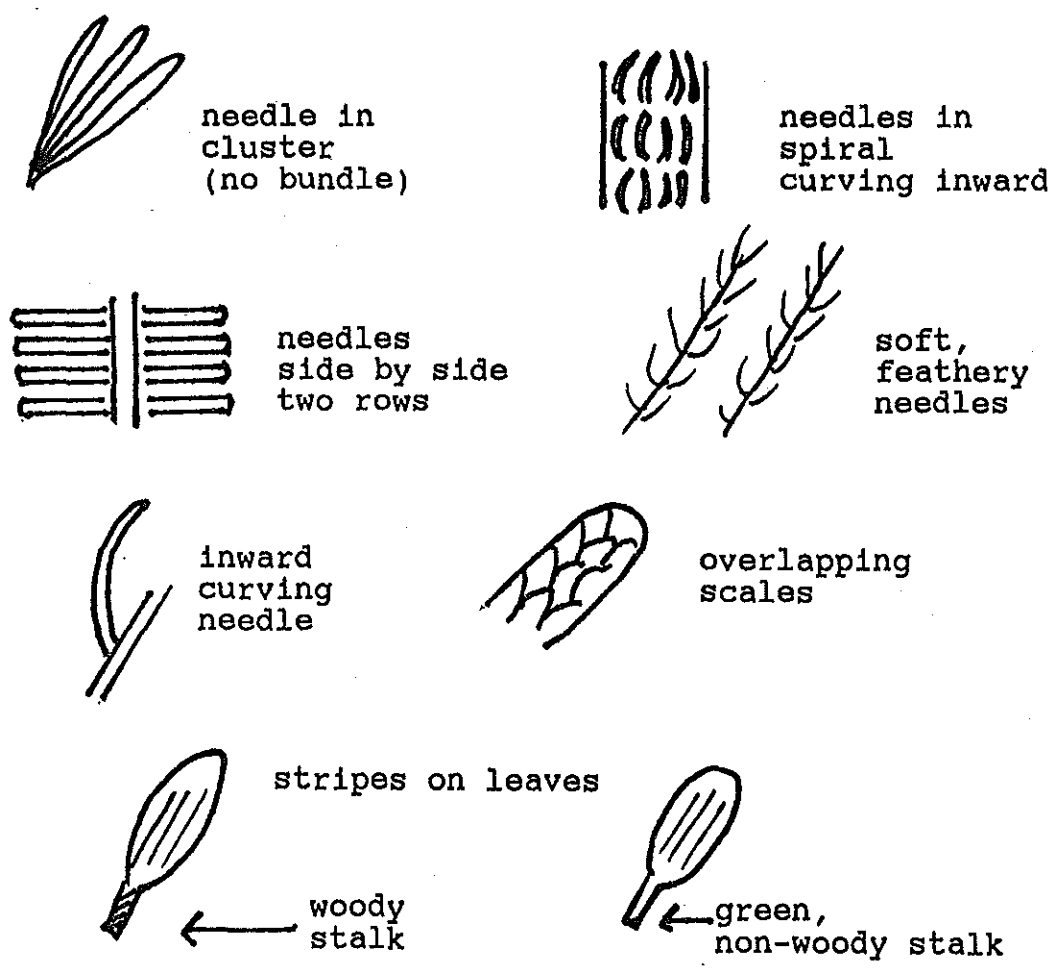

Conifer Key

Questions	If You Answer	
	Yes	No
1. Does the twig have leaves that look like needles?	Go to 2.	Go to 12.
2. Are the needles in groups of two or more?	Go to 3.	Go to 5.
3. Are the needles at least 5 cm long and are there 2 to 5 enclosed in a bundle?	This is a pine.	Go to 4.
4. Are the needles at least 5 cm long and are there 6 or more present but not enclosed in a bundle?	This is a larch.	Go to 5.
5. Do the needles curve inward and grow in a spiral pattern?	Go to 6.	Go to 8.
6. Are the needles soft and flat?	This is a Douglas fir.	Go to 7.
7. Do the needles have four sides? Are the needles sharp?	This is a spruce.	Go to 8.
8. Do the needles grow straight and side by side in two rows on the twig?	Go to 9.	Go to 10.

- | | | |
|--|-------------------------|------------------|
| 9. Are the leaves light colored, soft, and featherlike? | This is a bald Cypress. | Go to 10. |
| 10. Do the needles have gray stripes on the bottom and are they attached to the stem by a short woody stalk? | This is a hemlock. | Go to 11. |
| 11. Do the needles have two silver stripes on the bottom and are they attached to the stem by a short green stalk? | This is a fir. | Go to 12. |
| 12. Do the twigs have only one kind of leaf that looks like overlapping fish scales? | This is a cedar. | Go to 13. |
| 13. Do the twigs have two kinds of leaves--one that looks like overlapping scales and the other that looks needlelike? | This is a juniper. | This is the end. |

If you haven't named the plant, go to 1 again.

Identifying Conifers

Plant	Observations	Kind of Conifer
1	leaves like needles in groups of three	pine
2	needles soft and flat needles growing in spiral pattern	Douglas fir
3	two kinds of leaves (scales and needles)	juniper
4	needles that are flat and rounded on end; gray stripes on bottom of leaf	hemlock
5	leaves not needlelike but like overlapping scales	cedar
6	needles with four sides, sharp pointed needles	spruce
7	light green leaves, soft and featherlike	bald cypress
8	needles over 5 cm long, 6 or more leaves in a bundle	larch

¹From Biology Laboratory Experiences (p. 138) by A. Kaskel, J. Hummer, Jr., and L. Daniel, 1985, Columbus, OH: Charles E. Merrill. Copyright 1985 by Charles E. Merrill. Reprinted by permission.

TEACHER DISCUSSION: Stress need for careful observation. Review the pictorial key (Figure 1) with students to help them use it effectively.

The major plant groups of plants are the angiosperms and gymnosperms. Angiosperms are the group of flowering plants, including deciduous trees, shrubs, grasses. They are characterized by broad leaves, presence of flowers and fruit, both woody and soft (herbaceous) stems. Gymnosperms are the group most represented by cone bearing plants. They are characterized by needle-like leaves, woody stems, absence of flowers or fruit, presence of cones. This key uses common gymnosperms.

(Kaskel, Hummer, & Daniel, 1985, p. 137)

Activity #5 Using International System of Units

OBJECTIVE: To gain experience using SI measurements

SCIENCE PROCESS SKILLS: measurement, recording data

SCIENCE CONCEPTS: International System of Units, metric measurement

MATERIALS: metric ruler, diagrams of hand and foot

PREPARATION TIME: 45 minutes

TEACHER PROCEDURE:

1. Review with students markings on a metric ruler, distinguishing millimeters from centimeters.
2. Be sure students understand that they are to measure bones (Figure 2) rather than flesh outline.
3. Review how to make conversions in metric system by moving the decimal.

STUDENT PROCEDURE:

1. Measure in millimeters the lengths of the bones marked A, B, C, D and E on the hand diagram. Record your measurements on the data table.
2. Repeat with bones A-E on the foot diagram.
3. Measure the length of the thumb (total length) and record.
4. Repeat measuring length of big toe.
5. Change all millimeter measurements to centimeter measurements and record data on table.

Figure 2: Hand and Foot Bones

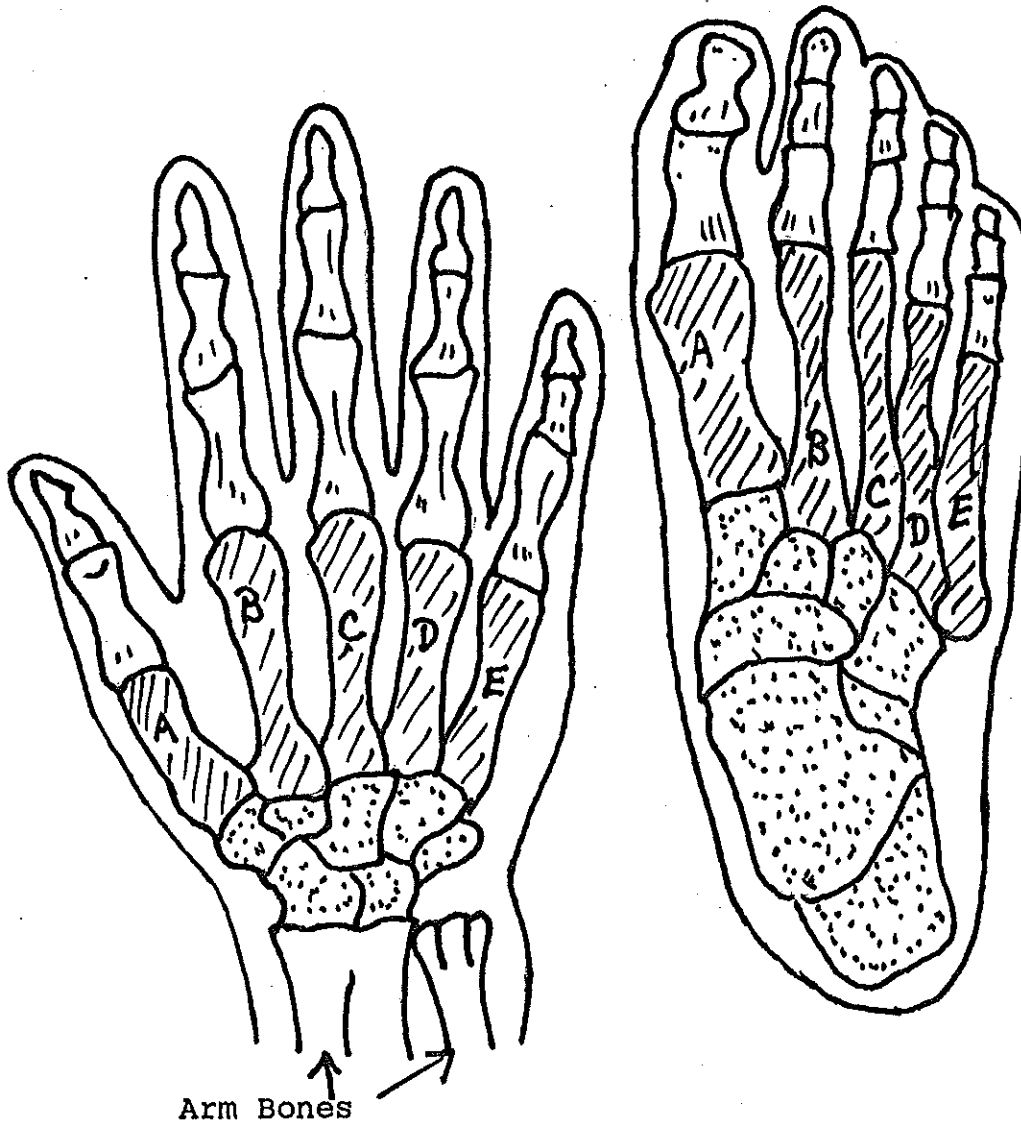

Thumb, fingers, and toes are white in these drawings. Palm bones and bones in center of the foot are striped. Wrist, ankle, and heel bones are spotted.

Table A: Measurements of Bones

Bone	Hand		Foot	
	mm	cm	mm	cm
Bone A				
Bone B				
Bone C				
Bone D				
Bone E				
Thumb or				
Big Toe Bones				
Smallest finger				
or Toe Bones				

TEACHER DISCUSSION: Discuss brief history of why SI (System International) measurements are preferable. Include in your discussion the universality, few units used and ease of conversion as the system is based on powers of ten.

This is a good exercise to stress construction of a data table. Emphasize the need for appropriate labels of measurements, tabular form when possible and units to accompany measurements.

This is also a good exercise to discuss why measurements may vary from student to student. Discuss careful technique and limitation of measuring instruments. For example, measurements can only be as accurate as the measuring instrument the student is using.

Metric Units

meter	length
liter	capacity
gram	weight

Metric Prefixes

kilo	1000 times base unit
hecto	100 times base unit
deka	10 times base unit
deci	1/10 of base unit
centi	1/100 of base unit
milli	1/1000 of base unit

To convert from a smaller unit to a larger unit, move the decimal point to the left the appropriate number of places. To convert from a larger unit to a smaller unit, move the decimal point to the right an appropriate number of places.

(Kaskel et al., 1985, p. 137)

Activity #6 Using Metric Measurements and Organizing Data

OBJECTIVE: To practice using instruments to make accurate metric measurements and to organize data into data tables

SCIENCE PROCESS SKILLS: metric measurement, organizing and collecting data

SCIENCE CONCEPTS: metric measurement

MATERIALS: metric rules, metric balances, bean seeds, graduated cylinders, plastic wrap, glass marking pencils, rectangular wooden blocks

PREPARATION TIME: 45 minutes

TEACHER PROCEDURE:

1. This activity requires students to follow directions and do mathematical calculations. It is designed for use with older students but could be modified for use with younger students.

2. Use baby lima beans or place beans in beakers to soak as beans swell too much to be removed from graduated cylinders.

STUDENT PROCEDURE:

Part A: Day 1

1. Accurately measure the length of 10 beans, one at a time. Place one block of wood at each end of the bean. Line the first block against the ruler so that its edge lines up with the 1.0 cm mark on the ruler. Place the

second block to the right of the bean and move it until its edge touches the bean. See the diagram (Figure 3). The space between the blocks is equal to the length of the bean. Enter this measurement in Table B.

2. Repeat this procedure with the remaining beans. Determine the average length of bean seeds.

Figure 3: Bean Between Blocks for Measurement

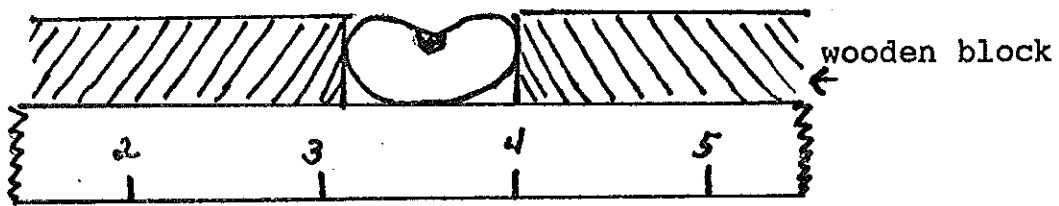

TABLE B: Record of Bean Measurements

Bean Number	Bean Length	Day 1	Day 2
1			
2			
3			
4			
5			
6			
7			
8			
9			
10			
Average			

3. Weigh an empty graduated cylinder. Record this weight on line 2 of Table C.
4. Add 50 mL of water to the cylinder. Weigh the water and the cylinder and record on line 1 of Table C.
5. Subtract line 2 from line 1 to calculate weight of water alone. Enter on line 3.
6. Weigh the 10 beans and enter on line 4.
7. Add the beans to the cylinder of water. Enter the weight of the cylinder, water and beans on line 5.
8. Enter the combined volume of beans and water in the cylinder on line 6.
9. Enter 50 mL (the volume of water you put in the cylinder) on line 7.
10. Subtract line 7 from line 6 to calculate the volume of the beans (line 8). Cover the cylinder with plastic wrap. Use a glass marking pencil to put your initials on the cylinder. Set aside overnight.

TABLE C: Record of Measurements to Determine Volume

Line	Measurement	Day 1	Day 2	Change
1	Wt. of cylinder and water			
2	Wt. of cylinder			
3	Wt. of water			
4	Wt. of beans			
5	Wt. of cylinder, water, and beans			
6	Vol. of water & beans			
7	Vol. of water			
8	Vol. of beans			

Part B: Day 2

1. Weigh the cylinder, water and beans. Enter line 5, day 2.
2. Measure the volume of water and beans (line 6, day 2).
3. Weigh a second graduated cylinder (line 2, day 2).
4. Pour the water from the original cylinder to the second cylinder. Weigh cylinder 2 again (line 1, day 2).
5. Subtract to calculate the weight of the water (line 3, day 2).
6. Record the volume of the water in the second cylinder (line 7, day 2).
7. Record the volume of the beans (subtract line 7 from line 6, day 2).

8. Empty the beans onto a paper towel and blot dry. Weigh the beans again (line 4, day 2).

9. Compare each of lines (except 1 and 2) under Day 1 and Day 2. Enter the amount of any change in the "change" column. Indicate whether the change was a gain (+) or loss (-).

10. Measure the length of each soaked bean as you did on Day 1. Enter this in Table B. Determine the average length of beans on Day 2.

ANALYSIS:

1. Was there any change in the total weights of the cylinder, water and beans?
2. How did the volume of water change?
3. How did the volume of the beans change?
4. Did the weight of the beans change?
5. Can you explain any difference between the loss of volume of water and the gain of volume of the beans?
6. In what way did the average length of the beans change overnight? Why do you think this happened?

TEACHER DISCUSSION: There are several laboratory techniques and use of equipment to be taught in this activity. Use of graduated cylinder and balance must be taught. The importance of accurate labeling of data and organization and sequence of data should be stressed. The difference between data (observation or measurements) and calculation

(mathematical manipulation of data) will need to be pointed out in regard to sequence of data table.

A. To use a beam balance follow these steps:

1. To ZERO the balance, use the damper as necessary.

A zero balance reads zero with all weights in a zero position.

2. Place the object to be weighted on the pan. If chemicals are to be weighed, use a piece of paper to cover and protect the pan.

3. Move the weights until the beam is swinging equally above and below the zero line.

4. Record the total of the weights.

B. To use a graduated cylinder, use the following steps:

1. With the cylinder at eye level, read the volume at the bottom of the MENISCUS. The meniscus is the crescent shaped curve seen at the surface of the liquid.

(Ramsey, Gabriel, McGuirk, Phillips, & Watenpaugh, 1986, p.13)

Activity #7 How Does An Organism's Color Affect Its
Survival?

OBJECTIVE: To relate adaptation to environment

SCIENCE PROCESS SKILLS: hypothesis, recording data,
inference

SCIENCE CONCEPTS: adaptation

MATERIALS: several boxes red and green toothpicks, watch
with a second hand

PREPARATION TIME: 10 minutes

TEACHER PROCEDURE:

1. It may be wise to mark off "territories" for each student. Restrict their activity to this area. Areas may have borders of non-activity between them to avoid crowding.

2. For younger students, colored straws would be safer and last longer.

3. Randomly scatter the toothpicks over the area. Instruct each student to gather only from his/her area. Have the students begin by covering one eye with their hand. On a given signal, allow students 20 seconds to gather as many toothpicks as possible. Have students record the number of each color toothpick they have collected. Repeat the step twice.

STUDENT PROCEDURE:

1. Copy the Table shown below. Pretend the green and red toothpicks are insects and you are a bird that eats insects.

2. When your teacher says "Go," cover one eye with your hand. Pick up as many toothpicks as possible with your other hand. Stop when your teacher says "Stop."

3. Count and record the number of each color toothpick you picked up.

4. Repeat steps 2 and 3 two more times. Find the total number of each color toothpick you picked up. Compare results with your classmates to find a total for the class. Which color toothpick was picked up most often? Why did you think this happened? Which color "insect" do you think has a better chance of surviving? Why?

TABLE D: Record of Numbers of Toothpicks

Toothpicks	Red	Green
<u>Trial 1</u>		
<u>Trial 2</u>		
<u>Trial 3</u>		

TEACHER DISCUSSION: Data should be organized, well labeled and in tabular form when possible. A Data Table should be clearly labeled as to quantity measured and units used, when appropriate. Stress to students the need for complete and accurate recording of data.

An OBSERVATION is a perception of objects or natural events using our senses. An INFERENCE is an explanation or interpretation of an observation.

The value of protective coloration as an adaptation can be demonstrated with this experiment. The red toothpicks should have the highest total collected on an average. The red toothpicks are more visible and the green toothpicks will blend into the grass or background more readily. Animals often have coloration that enables them to blend into the background and survive predation.

(Abruscato, Fossaceca, Hassard, & Peck, 1986, Level 4, p. 270)

Activity #8 Using the Scientific Method to Solve a Problem

OBJECTIVE: To test a prediction by experimentation, then draw a conclusion based on observation

SCIENCE PROCESS SKILLS: hypothesis, recording data, drawing a conclusion

SCIENCE CONCEPTS: scientific method, use of chemical indicators

MATERIALS: dropper bottles, 25 mL graduated cylinder, marking pencils, test tube rack (any container to hold test tubes upright), 4 test tubes, red cabbage juice, Chemical X (vinegar), Chemical Y (ammonia), Chemical Z (baking soda solution). Optional solutions: lemon juice, soap (not detergent), aspirin

PREPARATION TIME: 45 minutes

TEACHER PROCEDURE:

1. Prepare red cabbage juice by boiling outer leaves of cabbage in small amount of water. Do not add any seasonings. Cabbage juice should be refrigerated if kept overnight or longer. Juice will keep two to three weeks under refrigeration.

2. Label and fill "stock" bottles of chemicals X, Y, and Z. "Stock" bottles may be small dropper bottles with labels. Keep these containers closed when not in use.

SAFETY CAUTION: If chemicals are spilled on skin or eyes

wash with large quantities of water. These are common household solutions that cause little hazard.

3. Solution X is vinegar. It may be diluted slightly to minimize odor. Solution Y is ammonia. It may also be diluted slightly. Avoid overdilution. Solution Z is prepared by dissolving 5 grams baking soda in 95 mL of distilled water.

STUDENT PROCEDURE:

1. Predict what will happen to red cabbage juice when chemicals X, Y, and Z are added to it.

2. Label 4 test tubes 1, 2, 3, 4.

3. Add 10 mL of cabbage juice to each test tube.

4. Add 10 drops of chemical X to tube 1.

5. With a clean dropper, add 10 drops of chemical Y to tube 2.

6. With a clean dropper, add 10 drops of chemical Z to tube 3. Do all chemicals have the same effect on the cabbage juice? Record your observations.

7. Do not add anything to tube 4. This tube is the control. What is the purpose of the control in this experiment?

8. Record your observations in the Data Table. Did your hypothesis change after experimenting?

TABLE E: Record of Observations

Test Tube	Chemical Added	Final Color
1		
2		
3		
4		

TEACHER DISCUSSION: Review with students the steps of scientific method. These are: 1) define a problem, 2) research the problem, 3) form a hypothesis, 4) design an experiment, 5) conduct the experiment, and 6) draw a conclusion. Research might involve a demonstration with common acid/base indicators such as litmus paper. An acid/base indicator is a substance that changes color in the presence of an acid or base giving a visual clue as to the nature of a chemical. Litmus, for instance, is blue in the presence of a base and red in the presence of an acid. Common household acids include citrus juice, vinegar and aspirin. Household bases include ammonia, soaps and drain cleaner. Table salt is an example of a chemical that is neither acid nor base but neutral. Indicators do not change color with a neutral solution. Cabbage juice, as well as many flower pigments, is a natural indicator. Any bright colored flower, soaked in alcohol, will produce a solution that acts as an acid/base indicator.

Emphasis of this experiment should be on use of the scientific method rather than chemistry of solutions. Try

allowing students to suggest other safe household substances to test with cabbage juice to expand their collection of data and to draw a broad conclusion. The names of the chemical solutions X, Y, Z are not significant.

(Daniel & Kaskel, 1986, p. 9)

Activity #9 Solving a Problem with the Scientific Method

OBJECTIVE: To solve a problem using the scientific method

SCIENCE PROCESS SKILLS: hypothesis, observation, drawing a conclusion

SCIENCE CONCEPTS: scientific method

MATERIALS: 2 flasks (150 mL), watch with second hand, 2 corks to fit flasks, beaker, 10 grams sodium hydroxide, 10 grams glucose, 0.1 gram methylene blue powder, 10 mL ethyl alcohol, graduated cylinder

PREPARATION TIME: 45 minutes

TEACHER PROCEDURE:

1. This will be a good demonstration. Place all solutions in clearly labeled containers. To prepare solution A, place 10 grams sodium hydroxide in 1000 mL of water. (CAUTION: Sodium hydroxide is very caustic and produces heat when placed in solution. Avoid contact with skin and eyes. On contact flush with excessive amounts of water.) KEEP OUT OF STUDENT REACH. To prepare solution B, add 10 grams of glucose to 1000 mL of water. (Smaller amounts of solutions can be prepared by reducing components proportionally: for instance, place 5 grams of sodium hydroxide in 500 mL of water.) To prepare methylene blue solution dissolve 0.1 grams methylene blue powder in 10 mL of ethyl alcohol. You need only a small amount of this solution, 100 mL or less.

2. Label flasks before this activity. Flask A is half filled with an equal mixture of glucose and sodium hydroxide. Add several drops of methylene blue until solution is uniformly blue. Flask B is filled to the top with equal mixture of glucose and sodium hydroxide with methylene blue. BE SURE NO AIR SPACE EXISTS IN FLASK B. Add more methylene blue to the flasks during the day if color formation is weak.

STUDENT PROCEDURE:

1. Examine the two flasks and record observations. DO NOT remove the stoppers and DO NOT shake contents. Do you think both flasks contain the same liquid? Is your answer based on experimentation or guessing? Are both flasks exactly alike? List similarities and differences in the flasks on a data table.

2. Try an experiment. (Experiment 1). Give each flask one hard shake using an up-and-down motion. MAKE SURE YOUR THUMB COVERS THE CORK AS YOU SHAKE. Record your observations in your data table. After shaking the flasks, do you think they contain the same liquid? If there is a difference, what do you think caused the difference?

3. Try another experiment. (Experiment 2). Remove the cork from flask B and pour out half of the contents into a beaker or other container. Make sure the amount of liquid in flask B is equal to the amount in flask A. Give both flasks one hard shake using an up-and-down motion. Be sure

to hold the cork in place while shaking. Record your observations. What change may have caused the change in behavior of the liquid in flask B?

4. Optional (Experiment 3). Shake each flask hard once and note the exact time in seconds after shaking that it takes for each liquid to return to its original condition. Repeat with 2, then 3, shakes per flask recording time it takes for each flask to return to its original condition. After 2 and 3 shakes are the flasks generally "behaving" in a similar way? Do the flasks show an increase or decrease in time needed to return to its original condition as the number of shakes increases from 1 to 3?

5. (Optional). Run two more trials for each part of Step 4. Record your results. Do three trials give better evidence that flask A is "behaving" in a similar way to flask B? Do three trials give better evidence as to whether time needed to return to the original condition increases or decreases with increased shaking?

ANALYSIS:

1. On the basis of your first observations in Part A, could you decide if both flasks contained the same liquid?

2. After performing Experiment 1, could you decide if both flasks contained the same liquid?

3. Which experiment or experiments helped you decide that the liquids were similar or different?

TEACHER DISCUSSION: Emphasis should be on the steps used to solve a problem. Stress the role of experimentation in forming a conclusion. Increased numbers of trials increases data available and makes drawing a conclusion easier. It also reduces the probability of errors.

Both flasks contain the same mixture of liquids. In the presence of oxygen, the indicator methylene blue is blue in color. When oxygen is removed, methylene blue is bleached and colorless. The solutions without air (oxygen) will be colorless but shaking adds oxygen to the solution and changes the color of the methylene blue. Upon sitting, the oxygen leaves the solution into the air space above the liquid, therefore the mixture returns to the colorless condition. Additional shaking adds increased oxygen and lengthens the time needed to return to original condition. Therefore, the more shakes given the bottle, the longer the time needed for the solution to return to its original color.

(Kaskel, Hummer, Kennedy, & Oram, 1986, p. 13)

Activity #10 Testing Different Antiseptics

OBJECTIVE: To compare ability of household antiseptics to prevent bacterial growth

SCIENCE PROCESS SKILLS: hypothesis, experimentation, drawing a conclusion, distinguishing fact from opinion

SCIENCE CONCEPTS: factors influencing bacterial growth

MATERIALS: 4 apples, 4 cotton swabs, knife, masking tape, pen, 4 clear containers with lids (baby food jars or similar), 3 kinds of liquid antiseptics (rubbing alcohol, mouthwash, hydrogen peroxide, etc.)

PREPARATION TIME: 30 minutes

TEACHER PROCEDURE: none

STUDENT PROCEDURE:

1. Label each container with masking tape and pen. Put the name of each antiseptic on the label. Label the fourth container "Control".
2. With the first antiseptic wipe the inside of the container and its lid. Be sure not to miss any areas.
3. Scrape the skin off of a small area of one apple. Wipe the scraped area with antiseptic.
4. Place the apple in the container. Close the container tightly and place in a warm, dark area.
5. Repeat steps 1-4 with two other antiseptics.

6. Scrape the skin off a small amount of the fourth apple. Do not wipe the container or apple with any antiseptic. Place the apple in the container and close tightly. Place the container in the same place as the other three containers.

7. Check the containers every day for one to two weeks. Which apple changed first? Which apple took the longest time to show a change? Why did you put no antiseptic on the fourth apple?

TEACHER DISCUSSION: Distinguish among an observation, an inference and a prediction. An observation is information gathered through use of the senses. An inference is an explanation or interpretation of an observation. A prediction is a forecast of what a future observation will be.

(Trowbridge, Sund, Adams, & Hackett, 1980, p. 19)

Activity #11 Circadian Rhythms

OBJECTIVE: To combine data for a group and prepare a graph showing the range of circadian rhythms

SCIENCE PROCESS SKILLS: collecting data, graphing

SCIENCE CONCEPTS: circadian rhythms

MATERIALS: questionnaire

PREPARATION TIME: 15 minutes

TEACHER PROCEDURE:

1. Use the key to help students determine their score. Scores indicated on the teacher's key are added together and the sum converted into a morningness/eveningness scale as in Table F.

2. With student data, graph the morningness/eveningness scores on a graph. Morning/evening score should be placed on the horizontal axis and number of students on the vertical axis.

STUDENT PROCEDURE:

Answer questions on Morningness/Eveningness questionnaire as directed. In this investigation, you will collect information on morningness and eveningness.

Objectives

1. To determine through the use of the morningness/eveningness questionnaire, where your behaviors place you on the morning/evening scale.

2. To combine data for the entire class and prepare a graph showing the range of morningness and eveningness among classmates.

Directions:

1. Complete the questionnaire. Follow the instructions exactly.

2. Score your questionnaire as directed by your teacher. What is your score?

3. Record the number of students in each range of scores in Table F. Your teacher will help you.

4. Use the grid provided in Table G to make a graph illustrating the range of scores.

Horne-Ostberg

Morningness/Eveningness Questionnaire

survey instrument deleted, paper copy available upon request

survey instrument deleted, paper copy available upon request

survey instrument deleted, paper copy available upon request

survey instrument deleted, paper copy available upon request

survey instrument deleted, paper copy available upon request

survey instrument deleted, paper copy available upon request

Horne-Ostberg

Morningness/Eveningness Questionnaire

survey instrument deleted, paper copy available upon request

survey instrument deleted, paper copy available upon request

survey instrument deleted, paper copy available upon request

survey instrument deleted, paper copy available upon request

survey instrument deleted, paper copy available upon request

survey instrument deleted, paper copy available upon request

TABLE G: Class Range of Morningness/Eveningness Scores

Number of Students

Morningness/Eveningness Score

TEACHER DISCUSSION: Many organisms display circadian rhythms, including human beings. A circadian rhythm is a daily rhythm. There are many events that occur in cycles of 24 hours. These include sleep and waking patterns, work efficiency and many other physiological processes. People who feel more alert and report greater efficiency at varying times of the day feel so as a result of circadian rhythms.

The importance of this activity is the use of a qualitative survey to collect data scientifically. Qualitative data is not directly measurable but is observable. Quantitative data is directly measured. In this activity, qualitative data is converted to quantitative data.

(Creager et al., 1985, p. 291)

Activity #12 How Do Plants Respond To Light?

OBJECTIVE: To observe the reaction of plants to light

SCIENCE PROCESS SKILLS: observation, forming a hypothesis, recording observations, identification of variables, graphing

SCIENCE CONCEPTS: plant tropisms

MATERIALS: 3 small plants in pots, 2 shoe boxes, a piece of cardboard, tape, scissors, light source

PREPARATION TIME: 30 minutes

TEACHER PROCEDURE:

1. Choose three young plants that are of equal size. Geranium, coleus or bean plants grow quickly and are suitable for this exercise.

2. Boxes may be prepared in advance or this may be used as a demonstration.

STUDENT PROCEDURE:

1. Cut a hole in the top of one shoe box. Cut the hole to one side of the top. Label the box Plant 1.

2. With cut pieces of cardboard make a plant maze in the second box. Do this by taping alternating pieces of cardboard to opposite sides of the box at different heights. (Figure 4). Cut a hole in the middle of the top of the box. Label this box Plant 2.

Figure 4: Plants in Boxes

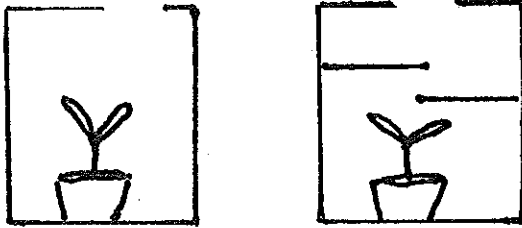

3. Do not place the third plant in any box. Label this Plant 3. What is the function of this plant?

4. Place all plants under the same light. Light should enter only through the hole at the top of the box. Be sure the plants are watered the same amount at regular intervals. After three days, observe the growth of the plants. Make observations at regular time intervals of several days. Record your observations.

TEACHER DISCUSSION: The concept of responding and manipulated variables (dependent vs. independent) may be introduced with this experiment. A variable is any condition that changes. MANIPULATED VARIABLES (independent) are those variables which are controlled by the experimenter, such as time interval between measurements, temperature at which plants are grown, type of medium on which bacteria are grown, etc. This variable is graphed on the horizontal or "X" axis of the graph. RESPONDING VARIABLES (dependent) are those variables which result from the experiment, such as amount of growth, weight gain, etc. These variables are graphed on the vertical or "Y" axis of the graph. Graphing may also be introduced with this

experiment. The role of the third plant as a control could be discussed at appropriate grade levels. The EXPERIMENTAL CONTROL is a standard against which observations and results can be checked. Plant 3 is serving as a control. Direction of light is not being used as a variable on this plant. Its function is the contrast of the effect of the variable.

This activity should be used to introduce plant response or tropisms. A TROPISM is an involuntary response to a stimuli exhibited by plants and sedentary animals, such as a plant response to light, gravity, or water. The response may be positive (toward) or negative (away). The tropism studied in this experiment is phototropism (response to light). Plant stems are positive in regard to phototropism. Plant stems are negative to geotropism (gravity) while roots are positive to geotropism. Roots are positive to hydrotropism (water).

(Shymansky et al., 1988, Level 3, p. 232)

Activity #13 Do Plants Need Soil to Grow?

OBJECTIVE: To demonstrate the adaptation of plants to growing in a variety of soils

SCIENCE CONCEPTS: adaptation, plant nutrition

MATERIALS: three plastic cups, pebbles, sand, potting soil, 6-9 presoaked bean or corn seeds, strips of colored paper (three different colors)

PREPARATION TIME: 20 minutes

TEACHER PROCEDURE:

1. Be sure all seeds are presoaked for 24 hours.

Beans, such as dried lima beans, may be purchased from a grocery store but corn must be the seed type from a garden store especially treated for germination.

2. This may be used as a demonstration. Graphing with colored strips of paper introduces the concept of graphing data without need for advanced math concepts. Time interval (manipulated variable) should be placed on "X" axis (horizontal) and plant height (responding variable) should be placed on "Y" axis (vertical). Be sure to label both axes clearly with quantity and units.

3. Do not overwater as seeds will mold.

STUDENT PROCEDURE:

1. Place pebbles in one cup, sand in second cup and soil in the third. Label each cup.

2. Plant 2-3 seeds in each cup. Place one or two small holes in the bottom of each cup.
3. Water your seeds each day. Use the same amount of water for each cup.
4. Keep the cups in a light, warm place. Observe plants once each day for 3 weeks.
5. Once a week match a strip of colored paper to the height of each plant. Use a different color for each cup, but use the same color for each cup each week.
6. Paste the strips of paper to a chart to form a graph. Be sure your graph has a title (a name that tells what it is about) and each side is labeled with units and quantity measured.

TEACHER DISCUSSION: Possible variations on this experiment exist such as using two or more different kinds of seeds to compare adaptation to varying soils by varying plants.

This activity can be used to demonstrate two concepts. These concepts are the ability of organisms to adapt to varying environments and the ability of plants to utilize materials not contained in soil to produce nutrients to carry out life processes. Students can be introduced to the function of soil as anchorage and as a reservoir of water and minerals to a plant rather than a source of "food". Discussion of the basic needs of a plant to carry out photosynthesis may be appropriate. Plants in all three containers should grow equally, or nearly equally, as well.

Photosynthesis is the process by which green plants produce carbohydrates as a source of energy. Necessary ingredients for photosynthesis are carbon dioxide and water. Light serves as a source of energy. Plants may then carry out photosynthesis in the absence of soil. This is contrary to student's belief that plants use soil as a source of nutrition.

(Shymansky et al., 1988, Level 1, p. 18)

Activity #14 How Does Water Get Into A Plant?

OBJECTIVE: To demonstrate the movement of water in a plant

SCIENCE PROCESS SKILLS: hypothesis, drawing a conclusion

SCIENCE CONCEPTS: translocation in plants

MATERIALS: potato, food coloring, knife, toothpicks, small bowl or container for water

PREPARATION TIME: 30 minutes

TEACHER PROCEDURE:

1. For best results, use a small potato with "eyes".
2. Place toothpicks around the potato in a circular pattern at approximately midpoint of the potato. These will support the potato in the container.
3. Fill the container with water and place the potato so that about one half of the potato is in the water. Place this in a warm, light place until roots begin to appear. Change water and dye twice weekly for best results. It may take up to 3 weeks for potato to absorb the dye.

Figure 5: Potato in Beaker

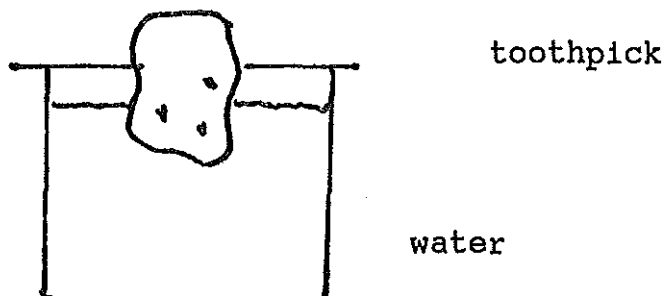

STUDENT PROCEDURE:

1. Obtain from your teacher a potato that has started to grow roots in a container of water. Mix red food coloring in the water. Be sure the water is a dark red.
2. Place the potato in a warm, light place for a few weeks. How did the potato change?
3. Cut the potato in half. What do you see?
4. How do you think this happened?

TEACHER DISCUSSION: Water and food move through a plant by a process called translocation. Water is carried from roots to the stems then the leaves through a specialized tissue called xylem. Food moves from the leaves to the roots through phloem. In this experiment, water is absorbed by the xylem of the roots and moved into the potato (stem). Water moves into the roots by a process called osmosis. Osmosis is the movement of water from an area of high water concentration to an area of lower water concentration. Water is in the highest concentration in the container, therefore it moves into the root. Water is then in higher concentration in the root than in the potato, therefore it moves into the potato. The dye that is dissolved in the water will be carried with the water into the potato. Consequently, after several days the potato will appear red when cut in half. Plants depend on osmosis to move water throughout their bodies.

(Abruscato et al., 1986, Level 2, p. 192)

Activity #15 How Do Roots and Stems Grow?

OBJECTIVE: To demonstrate plant response to gravity

SCIENCE PROCESS SKILLS: drawing a conclusion

SCIENCE CONCEPTS: plant tropisms

MATERIALS: 4 bean seeds, paper towels, 2 glass squares or slides, shallow tray, 2 rubber bands or masking tape, coleus or geranium in flowerpot

PREPARATION TIME: 20 minutes

TEACHER PROCEDURE:

1. Presoak bean seeds in water for about one hour. Dried lima beans from the grocery store work well.
2. Once beans have been placed between the glass, check them daily as swelling may loosen the rubber bands or tape.
3. Each bean has a notch on its edge. When positioning seeds, use the notch to determine differences in direction to be planted. Once seeds have been positioned between the glass, keep them in a warm, dark place for sprouting.
4. If you do the optional activity, you may want to cover the top of the pot with foil or plastic wrap to keep the soil from spilling out as the flowerpot is turned on its side.

STUDENT PROCEDURE:

1. Wrap a piece of glass in a sheet of paper towel. Place four seeds on the towel, each turned a different way. (One up, one down, one right, one left).

2. Place a second piece of glass on top of the seeds to make a "sandwich". Use rubber bands or masking tape to hold the glasses together. CAUTION: Be careful handling the glass. Wrap the pieces just tight enough to hold the seeds in place.

3. Set the pieces of glass upright in a tray or dish of water, as shown in Figure 6. Keep seeds in a warm, dark place for 3 to 4 days, then observe. What do you notice about the seed roots? What do you notice about the seed stems?

4. (OPTIONAL) Lay a flowerpot with a plant on its side. Place a book or block of wood on each side of the pot to keep it from rolling. Observe the plant in a few days. How has it changed?

Figure 6: Beans Between Glass Slides

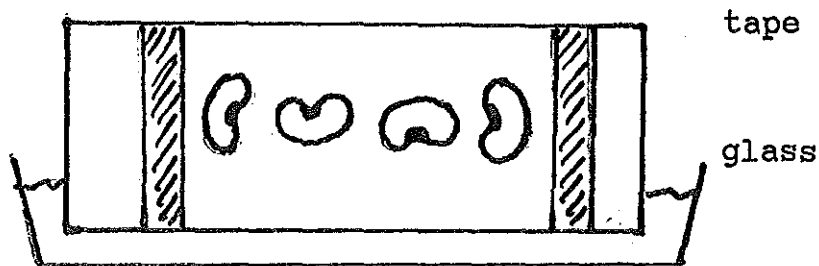

TEACHER DISCUSSION: A plant response to a stimuli is called a tropism. In this experiment a plant's response to gravity, geotropism, will be observed. Tropisms are considered positive if the growth is toward the stimuli and negative if growth is away from stimuli. Plant roots exhibit positive geotropism and stems exhibit negative geotropism. Leaves do not exhibit geotropism. The roots of all seeds should be growing downward and stems growing upward no matter what direction the seed was planted.

The potted plant, given time, will also show negative geotropism. The younger the plant the faster it will demonstrate response.

Tropisms are controlled by plant hormones called auxins. Auxins cause elongation of cells. In turning a plant organ, cells on one side of the organ elongate faster than those cells on the opposite side because of the influence of the auxin. Auxins also are present in the tips of roots, branches and stems, resulting in rapid growth of these areas. Remember that plant stems grow from their tip upward only and roots grow from their tip downward only.

(Shymansky et al., 1988, Level 3, p.222)

Activity #16 How Does A Plant Grow Taller?

OBJECTIVE: To demonstrate the growth pattern of a plant

SCIENCE PROCESS SKILLS: experimentation, collecting data,
drawing a conclusion

SCIENCE CONCEPTS: Meristematic tissue

MATERIALS: bean or other fast growing seeds (sunflower
seeds), small container (baby food jars, paper cups),
potting soil, marking pen, centimeter ruler

PREPARATION TIME: 20 minutes

TEACHER PROCEDURE:

1. Presoak seeds for an hour before planting. Planting seeds of different kinds will allow students to compare growth in plants.

2. Avoid overwatering the seeds as they will develop mold.

STUDENT PROCEDURE:

1. Plant 2 to 3 seeds in a pot of soil. Place the seeds about one centimeter below the surface. Water the seeds just enough to keep the soil moist. Place the pots in sunlight.

2. When the young plants are at least 7 centimeters high, mark the stems carefully with a marking pen at 2, 4 and 6 centimeters above the soil. What do you think will happen to the height of these marks as the plants grow?

3. After 3-4 days, measure the height of the three marks above the coil. How do plants get taller? Do stems grow at the top, at the bottom, or all along the stem?

4. (Optional) Try more than one type of seed. Do all plants grow the same way or differently?

TEACHER DISCUSSION: Plants consist of 4 basic types of tissue: meristem, epidermis, vascular, and ground tissue.

Meristem tissue is an area of rapidly dividing cells. These cells are undifferentiated and undergoing constant cell division. Epidermis tissue is a protective cell layer. Vascular tissue is specialized for transport of food and water. Ground tissue consists of slightly specialized cells that support and protect vascular tissue.

Growth in length of stems and roots occurs only in meristem tissue that is located at the tip of the stem and roots. As the cells divide and mature they change from meristem tissue to one of the three other types. Therefore all growth is limited to stem and root tips. The marks at 2, 4 and 6 cm will remain the same height from the soil as the stem elongates.

(Cooper, Blackwood, Boeschen, Giddings, & Carin, 1985, Level 4, p. 285)

Activity #17 Testing for Starch in Plant Leaves

OBJECTIVE: To test for the presence of starch in plant leaves

SCIENCE PROCESS SKILLS: experimenting, drawing a conclusion

SCIENCE CONCEPTS: photosynthesis

MATERIALS: methyl alcohol, iodine solution, green leaves, hot plate, forceps or tongs, beakers, test tube

PREPARATION TIME: 20 minutes

TEACHER PROCEDURE:

1. Due to the possible chemical hazard, you may wish to do this experiment as a demonstration.

2. Obtain a small amount of iodine solution from the drug store or Lugol's solution from a supply house.

3. Use caution with methyl alcohol as it absorbs through skin and is toxic. Also use caution as methyl alcohol is flammable.

4. A preliminary test with iodine to demonstrate the presence of starch should be demonstrated. Place iodine on such foods as a raw white potato slice, a piece of bread, a few grains of boiled rice. The starch will cause the iodine to turn blue-black. Have students suggest what common food group these all contain. These are all starchy foods. For comparison and a negative test, add iodine to such foods as table sugar or margarine. Since these foods do not contain

starch, the test will be negative and the starch will not change color.

STUDENT PROCEDURE:

1. Tear two green leaves from a plant that has been in sunlight into several pieces. Place the leaves in a beaker and add enough water to cover the leaves.

2. On a hot plate, boil the leaves for about 5 minutes.

3. Turn off the hot plate. Using forceps or tongs, remove the leaves from the beaker and place them in a test tube.

4. Fill the test tube about one half full of methyl alcohol.

5. Place the test tube in a beaker of water. Heat the water GENTLY for 5 minutes. DO NOT BOIL THE WATER. DO NOT ALLOW ALCOHOL TO TOUCH THE HOT PLATE.

6. Remove the leaves and rinse with water. Blot the leaf dry with a paper towel.

7. Place the leaf on a paper towel and add a few drops of iodine to the leaf. What did you see?

TEACHER DISCUSSION: This experiment is useful in demonstrating the products of photosynthesis. The ingredients of photosynthesis are carbon dioxide and water. Light is necessary to provide energy and chlorophyll is needed to trap the light energy. Products of photosynthesis

are glucose (simple sugar) and oxygen. Since sugar will dissolve in water and would be washed out of the plant, the plant changes glucose to an insoluble starch for storage. Plant leaves exposed to sunlight contain starch.

A positive test for starch is iodine changing from reddish brown to purple or black. Use the common foods to demonstrate the positive starch test. Boiling the leaves kills the cells and breaks down cell walls. The methyl alcohol then removes the chlorophyll from the leaf so that starch can be seen. Rinse the iodine solution off the leaf to show the reaction. It may take 2-5 minutes for the reaction to occur.

(Summerlin, 1979, p. 131)

Activity #18 Do Plants Need Light to Make Food?

OBJECTIVE: To demonstrate the need for light in photosynthesis

SCIENCE PROCESS SKILLS: observation, experimentation, drawing a conclusion

SCIENCE CONCEPTS: the role of light in photosynthesis

MATERIALS: adult geranium plant, aluminum foil, hot plate, beaker, tongs, iodine solution, methyl alcohol

PREPARATION TIME: 30 minutes

TEACHER PROCEDURE:

1. Place an adult geranium in total darkness for 24 to 48 hours.

2. At the start of the experiment, test some of the leaves of this light deprived plant for the presence of starch (see Activity #17 for procedure). These leaves serve as a control.

3. Have students cover a few of the leaves of the plant with aluminum foil or cover part of a leaf with disks of cardboard. The rest of the leaf should be left uncovered to serve as a control.

4. Place the plant in sunlight or artificial light from a 75-watt bulb about 2 feet from the plant. Leave the plant in light for about 24 hours.

5. Remove the covered leaves. Uncover the leaf. Place the leaves in boiling water, then heated alcohol and treat with iodine as already described to test for starch.

STUDENT PROCEDURE:

1. Use a plant that has been in a dark environment for at least 24 hours. Remove one leaf and test for the presence of starch.

2. Place the leaf in boiling water for 5 minutes.

3. Remove the leaf to a test tube. Cover the leaf with methyl alcohol.

4. Place the test tube in a beaker of water and heat gently for 5 minutes. Dry the leaf with paper towels and drop iodine solution on the leaf. What are the results?

5. Cover some of the leaves of the plant with aluminum foil or part of some leaves with disks of cardboard. Place the plant in bright sunlight or an artificial light for 24 hours.

6. Remove the covered leaves and their coverings. Test for starch in the same way as steps 2, 3, and 4. How do the covered and uncovered parts of the leaves differ?

Figure 7: Geranium Plant with Covered Leaf

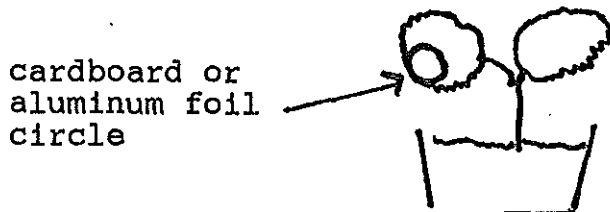

TEACHER DISCUSSION: The plant placed in darkness has not undergone photosynthesis and therefore the leaves should test negative for the presence of starch (no blue black color should appear). This should serve as a control. When exposed to light, only the exposed leaves or parts of leaves should show a positive test for starch. Light provides the energy for the chemical reaction that changes carbon dioxide and water to sugar (glucose) and oxygen. Sugar is then converted by the plant to a more storable form, namely starch. The covered parts of the leaves did not undergo photosynthesis and should test negative for starch.
(Morholt, Brandwein, & Joseph, 1966, p. 163)

Activity #19 How Are Seeds Adapted for Dispersal?

OBJECTIVE: To compare the adaptation of seeds for dispersal

SCIENCE PROCESS SKILLS: observation, classification, inference, collecting data

SCIENCE CONCEPTS: seed dispersal, adaptation

MATERIALS: a variety of seeds, a shallow pan, brown paper, a piece of flannel or old tube socks

PREPARATION TIME: 10 minutes

TEACHER PREPARATION:

1. This activity is designed to utilize wildflower seeds, therefore the best time to try this exercise is the spring or early summer when most seeds are available. If possible use this as an outside activity to collect seeds. A vacant lot or unmowed area works well. Scout the area before the exercise to preview the variety and location of seeds available.

2. Use of old socks for part of the test helps students relate their experiences to seed dispersal.

STUDENT PROCEDURE:

1. Collect as many different types of seeds as possible. Find seeds from weeds, trees, and wildflowers.

2. Place each seed on a piece of paper on a table. GENTLY blow on the seed from the side of the paper. Does it fly? Make a data chart to record your observations. Place

the name of the plant seed along the side of your chart. Across the top of your chart label columns for each test. Record your observation in a column labeled "Flies in Wind."

3. Place each seed on a piece of old sock or cloth. Does the seed stick? Record your observations in a column labeled "Carried on Clothes".

4. Put each seed, one at a time, into a pan of water. Does the seed float? Place your observation in a column "Floats in Water."

5. Mount the seeds on brown paper under the headings "Carried by Water", "Carried by Wind", "Carried by Animals".

TEACHER DISCUSSION: Seed dispersal is an adaptation by plants to help spread seeds as far as possible from the parent plant. Dispersal is one of the functions of a seed along with protection of the embryo plant. By spreading young plants, competition between the seedling and the mature plant for water, light and minerals is reduced.

Types of adaptations include hooks for attachment to animal fur, wings for wind, round shape for rolling, etc. (Abruscato et al., 1986, Level 2, p. T216)

Activity #20 Does Yeast Make A Gas As It Grows?

OBJECTIVE: To observe the products of fermentation

SCIENCE PROCESS SKILLS: experimentation, inference

SCIENCE CONCEPTS: alcoholic fermentation

MATERIALS: balloon, bottle, bowl, measuring cup, spoon,
sugar, dried yeast, water

PREPARATION TIME: 20 minutes

TEACHER PROCEDURE:

1. Yeast mixture can be placed in any bottle with a neck narrow enough to fit a balloon over. Prestretch the balloon to allow easy inflation. Do not use too large a balloon as the amount of gas collected will not be large enough to inflate a large balloon. Likewise, do not use too large a bottle as the gas produced must fill the air space above the liquid before it will start inflating the balloon.

2. Dry yeast usually dissolves best when water temperature is between 105 and 115 degrees. The water will feel warm to the fingertips but not hot. After mixing the yeast and attaching the balloon, place the bottle in a WARM place for best results.

STUDENT PROCEDURE:

1. Put 500 mL of water and 125 mL of sugar in a bowl. Add a package of yeast and stir.

2. Pour the mixture into a bottle. Fasten a balloon over the neck of the bottle. Then place the bottle in a warm, dark place.

3. Observe the bottle 2 or 3 times a day for the next 2-3 days. What is happening to the liquid in the bottle? What is happening to the balloon? Why do you think this is happening?

4. After 3 days, carefully remove the balloon. How does the liquid smell?

TEACHER DISCUSSION: This experiment demonstrates the process of alcoholic fermentation. Yeast uses the sugar for a source of food. As a control, you might repeat this procedure omitting the sugar in the yeast-water mixture. The yeast will have no source of food and no gas will be produced as no fermentation occurs.

Alcoholic fermentation is a chemical process in which cells use sugar as a source of energy. The products of this reaction include ethyl alcohol and carbon dioxide. The carbon dioxide will inflate the balloon and the resulting mixture will smell of alcohol. Many smaller organisms produce energy by this process but the disadvantage is the small amount of energy released for the organism's use. Larger organisms such as multicellular plants and animals must use the process of aerobic respiration to produce energy. Aerobic respiration uses sugar to release energy but the products are carbon dioxide and water not alcohol.

The amount of energy released is greater and oxygen must be used to release this energy.

(Abruscato et al., 1986, Level 3, p. T50)

Activity #21 Fermentation and Apple Cider

OBJECTIVE: To make apple cider by the process of fermentation

SCIENCE PROCESS SKILLS: hypothesis, experimentation, drawing a conclusion

SCIENCE CONCEPTS: alcoholic fermentation

MATERIALS: ripe apples, knife, beaker, mortar and pestle (or a food processor), clean old pillow case or muslin cloth, 125 mL Erlenmeyer flask with one-hole stopper to fit, short length of glass tubing, short length of rubber tubing

PREPARATION TIME: 30 minutes

TEACHER PROCEDURE:

1. This is a good experiment as a group project or demonstration. Be sure to use all new or very clean glassware. Do not allow students to put the glass tubing into the rubber stopper as it is likely to break. To insert glass tubing into a stopper, wet the tubing with water. Wrap a cloth around the tubing and with a gentle twisting motion insert the tubing into the stopper. **AVOID PUSHING THE TUBING.** Attach the rubber tube to the glass tube. If you can find plastic tubing to use it will work just as well.

2. Use caution in tasting any products. Tasting is almost never allowed in science lab because of possible danger. Remind your students of this hazard.

3. Keep your "cider mill" in a warm and dark place for best results.

STUDENT PROCEDURE:

1. Cut an apple into small pieces. Crush the apple using a mortar and pestle or food processor.
2. Place the crushed apple into a piece of muslin and squeeze as much juice from the apple as you can into a beaker.
3. Pour the apple juice into an Erlenmeyer flask, filling it to within 4 cm from the top.
4. Place the assembled stopper into the flask.
5. Rinse out the beaker and fill it with water. Put the free end of the rubber tubing into the water and leave it there (see Figure 8).
6. Let the flask stand in a warm, dark place for 2 or 3 days. Check your "cider mill" from time to time to see if any evidence of a reaction is taking place. After 2 or 3 days, take a small amount of the apple juice out of the "cider mill" and place a small amount on your tongue. What do you taste?

Figure 8: Arrangement of "cider mill"

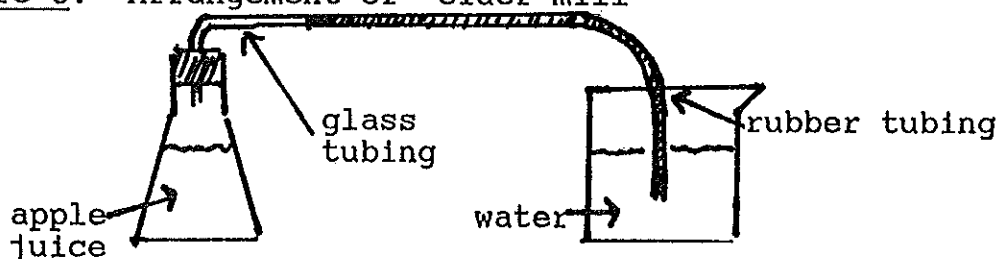

TEACHER DISCUSSION: In this activity, you are fermenting the carbohydrate (sugar) in apples to produce carbon dioxide and ethyl alcohol, known as "cider". Yeast is a natural contaminant of the atmosphere and is normally found on the skin of any apple. Be sure not to peel the apple, thus insuring that yeast is available.

After a day or so, gas bubbles will begin to escape from the rubber tubing in the beaker. This indicates the formation of carbon dioxide as the yeast carries out fermentation.

(Summerlin, 1979, p. 14)

Activity #22 Diffusion

OBJECTIVE: To observe the movement of water into and out of cells

SCIENCE PROCESS SKILLS: hypothesis, experimenting, drawing a conclusion

SCIENCE CONCEPTS: osmosis

MATERIALS: 2 beakers (400 mL), carrots (potato chunks can be used), metric ruler, salt, knife, thread or string

PREPARATION TIME: 10 minutes

TEACHER PROCEDURE:

1. You may wish to prepare a salt water solution in advance. Simply add salt to a quart of water until no more salt will dissolve in the water.

2. If you wish to let students make their own salt water, you may prepare paper cups with 1-2 tablespoons of salt already measured out.

3. You may also wish to cut the carrots in half yourself. Be sure to use fresh vegetables as older vegetables will not give as good a result.

STUDENT PROCEDURE:

1. Fill two beakers half full with water.
2. To one beaker, add salt and stir. Label this beaker "salt water."

3. Cut a carrot in half. Tightly tie a piece of thread around each piece of carrot. Tie the thread two centimeters below the cut end of the carrot.

4. Place one carrot in the beaker of salt water, cut end down and the other carrot in the beaker of plain water cut end down.

5. Leave the carrots in the water for 24 hours. Then remove the carrots and observe the tightness of the threads. Record your observations in the table.

Figure 9: Carrot with String

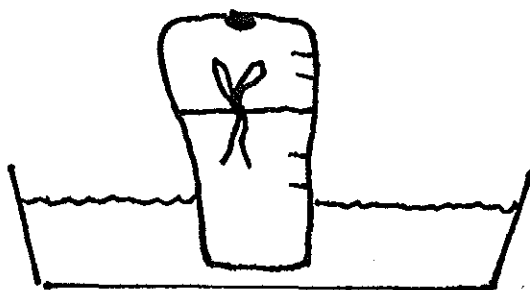

TABLE H: Observation of Carrots in Water
(circle the type of water that matches the description of the carrot in column "Condition")

CONDITION	WATER TYPE	
	Fresh water	Salt water
Thread loose	Fresh water	Salt water
Firm Texture	Fresh water	Salt water
Tight Thread	Fresh water	Salt water
Soft texture	Fresh water	Salt water
CONCLUSIONS:		
Loss of water by cells	Fresh water	Salt water
Gain of water by cells	Fresh water	Salt water

TEACHER DISCUSSION: As more air is put into a tire, the larger and more firm the tire becomes. If there is a leak, the tire may decrease in size and become soft. Living cells that are full of water are firm and larger. This condition is called turgor. Cells that lose water may become soft and shrivel, a condition called flaccid. Water moves into and out of a cell by a process called osmosis. Water moves from areas of high concentration to areas of lower concentration. Addition of a solute, such as salt, to water makes the water concentration in the solution less. Therefore the water concentration in the pure water beaker was higher than the water concentration in the salt water solution. Cells in the carrot have water concentration higher than the concentration of the salt water. Water moves out of the carrot and the carrot becomes flaccid. Carrot cells have a water concentration lower than pure water therefore water moves into the carrot and it becomes turgid.

Plants use osmosis to move water from soil to roots and throughout their body. Osmosis pressure also helps support plant cells and keep them firm.

(Daniel & Kaskel, 1986, p. 25)

Activity #23 Osmosis in Eggs

OBJECTIVE: To demonstrate osmosis using the membrane of an egg

SCIENCE PROCESS SKILLS: hypothesis, experimentation, drawing a conclusion

SCIENCE CONCEPTS: osmosis

MATERIALS: raw uncracked eggs, clear vinegar, clear syrup, large wide mouth jars

PREPARATION TIME: 10 minutes

TEACHER PROCEDURE:

1. As the eggs will increase significantly in size, be sure to use small eggs and large mouth jars such as mayonnaise jars.
2. Do not remove the eggs from their shell.

STUDENT PROCEDURE:

1. Place a raw egg in a wide mouth jar. The egg should be much smaller than the mouth of the jar.
2. Add enough vinegar to more than cover the egg. Place a cap on the jar to keep the odor in the jar.
3. Set the jar aside for two days. However, make frequent observations of the egg for the first 2 to 3 hours. What noticeable effect does the vinegar have on the egg shell within 1 to 2 hours?

4. After two days, describe the egg. How has the egg changed? What do you think caused this change?

5. After making your observation, carefully pour the vinegar off the egg. Wash the egg several times by adding water to the jar then pouring it off. Remember, a thin membrane is holding the egg together so don't break the egg.

6. Add enough clear syrup to more than cover the egg.

7. Set the jar aside for two days. After the second day, observe the egg again. Describe the egg. How has it changed? What do you think caused this change?

TEACHER DISCUSSION: In this experiment you are demonstrating osmosis. Osmosis is the movement of water through a semipermeable membrane from areas of high concentration to areas of lower concentration of water. A semipermeable membrane is one that allows the passage of select materials but not all materials into and out of the cell. The egg membrane is a semipermeable membrane. To expose the membrane, vinegar is used to partially dissolve the egg shell. Vinegar is a weak solution of acetic acid. Once the shell is partially dissolved, the concentration of water outside the egg is greater than inside the egg. Water will enter the egg due to osmosis. This will cause the egg to increase in size.

By placing the egg in syrup, you will reverse the osmosis. Since the water concentration inside the egg is

higher than in the syrup, water will move out of the egg. The egg will shrink.

Osmosis will only occur when there is a concentration difference, called a concentration gradient. Water will move from higher concentration to lower concentration until water on both sides of the membrane is equal. This is called equilibrium. In equilibrium water is still moving into and out of the membrane, but at equal rates.

(Summerlin, 1979, p. 89)

Activity #24 Making a Cell Model

OBJECTIVE: To make a model of a typical cell

SCIENCE PROCESS SKILLS: using a scientific model

SCIENCE CONCEPTS: structure of a cell

MATERIALS: corn starch, small plastic bag such as a sandwich bag, cup, teaspoon, string, scissors, iodine solution, bowl, water, funnel (optional)

PREPARATION TIME: 20 minutes

TEACHER PROCEDURE:

1. Any small plastic bag will be appropriate. Be sure that the outside of the bag is rinsed to remove any spilled starch solution, as it may give students a false conclusion.

2. If students are not familiar with the starch-iodine reaction, you may want to demonstrate a positive test by adding a few drops of iodine to a small amount of starch solution in a test tube or jar. A good comparison is to add iodine to a sugar solution to demonstrate a "negative" iodine test.

STUDENT PROCEDURE:

1. Add a teaspoon of starch to a cup of warm water. Stir to dissolve the starch.

2. Pour the mixture into a plastic bag. Tie the bag tightly with string. Rinse the outside of the bag to wash away any spilled starch.

3. Pour a small amount of warm water into a bowl. Add just enough iodine solution to turn the water a light tan. Place the bag in the bowl. What happens after a short time?

TEACHER DISCUSSION: A scientific model is an example or reconstruction of an object that allows a student to understand the real object or process. In this experiment, the cell membrane is represented by the plastic bag. The cell membrane is selectively permeable. It allows some molecules to enter or leave the cell but not all molecules. The starch molecules could not leave the "cell" but the iodine molecules could enter the bag. Large molecules, such as starch, or undissolved molecules cannot pass through the cell membrane. Smaller, dissolved molecules can pass through the membrane. The smaller iodine molecules passed into the cell but the large starch molecules could not pass out of the cell.

(Cooper et al., 1985, Level 5, p. 12)

Activity #25 How Do Insects Develop?

OBJECTIVE: To observe the metamorphosis of insects

SCIENCE PROCESS SKILLS: observation

SCIENCE CONCEPTS: animal development, metamorphosis in insects

MATERIALS: mealworms, clear plastic container, cereal, fruit or vegetable, cheesecloth, small glass dish, hand magnifying glass

PREPARATION TIME: 20 minutes

TEACHER PROCEDURE:

1. This is a good project to demonstrate insect metamorphosis. Mealworms can be obtained from a pet shop or biological supply house.

2. Place about a dozen mealworms in a clear plastic container filled to about a 10 cm level with bran, oatmeal, or other raw cereal. The container need not be covered as mealworms avoid light and therefore will not try to leave the container.

3. Place a piece of raw fruit or vegetable, such as lettuce, potato, or apple, in the container to keep the cereal moist but not wet, and as a source of food. Every few days remove the fruit and replace it with a fresh piece.

4. When adult beetles appear (at a temperature of 86 F, complete life cycle may take up to 4 to 6 months), keep the container loosely covered with a piece of

cheesecloth. Check the container each week for overcrowding. If the culture becomes too crowded, adults may fight.

5. Each week remove some of the developing beetles and place in a small dish for closer examination. Use forceps carefully to avoid crushing the larva.

STUDENT PROCEDURE:

1. Carefully remove some of the insects and place them in a small dish. Use a hand magnifying glass to observe your insects.

2. Make observations in your data table each week about the animals' appearance. How are they changing?

TEACHER DISCUSSION: Mealworms are actually the larval stage of the beetle, Tenebrio. These insects undergo development in complete metamorphosis. The four stages of complete metamorphosis are egg, larva, pupa, and adult. In complete metamorphosis, immature stages do not resemble the adult. Growth and development are accompanied by a shedding of the exoskeleton, a process called a molt. The larva stage, called a mealworm, is worm like, brown in color, and ranges in size from 1 to 2 centimeters. They burrow through the culture like worms. The pupa does not move, is shorter, fatter and lighter colored than the larva. Adult beetles are dark brown to black.

Incomplete metamorphosis is completed in three stages: egg, nymph, and adult. The immature stage resembles the adult except for the lack of wings. Molting is also required for growth and development. Metamorphosis reduces the competition of insects for food because immature stages eat different food than do adult stages. It also allows the animal to survive unfavorable environmental conditions. (Shymansky et al., 1988, Level 4, p. 262)

Activity #26 What Do the Hearts of Different Animals Look Like?

OBJECTIVE: To compare 2, 3 and 4 chambered hearts

SCIENCE PROCESS SKILLS: scientific models

SCIENCE CONCEPTS: vertebrate heart structure

MATERIALS: 9-7 oz. plastic cups, scissors, 6 straws, 3 different colored pencils, metric ruler, tape

PREPARATION TIME: 30 minutes

TEACHER PROCEDURE:

1. Make copies of the circles shown in Figure 10 for students. Students need 3 small circles and 1 large circle for each group. Circles fit 7 oz. cups so if you have larger cups you will have to adjust.

2. You may want to cut straws in advance to reduce student error and save time.

3. Tags may be made from colored paper rather than using colored pencils to show flow of blood. Use red to show oxygenated blood, blue for deoxygenated blood, and purple for a mixture of oxygenated and deoxygenated blood.

STUDENT PROCEDURE:

PART A: Preparing Model Parts

1. Measure up 4 cm from the bottom of each of 5 cups. Cut each cup bottom off at this point. These small cups

will be the top chambers of the hearts you make. Throw away the top rings of the cups.

2. Cut out the three small circles and one large circle as shown in Figure 10. Be sure to cut the flaps in the centers of the circles as shown. The circles will be walls between the top and bottom chambers of the hearts.

3. Cut three straws in half. Leave three straws uncut. The straws will be blood vessels.

Figure 10: Circles for Heart Models

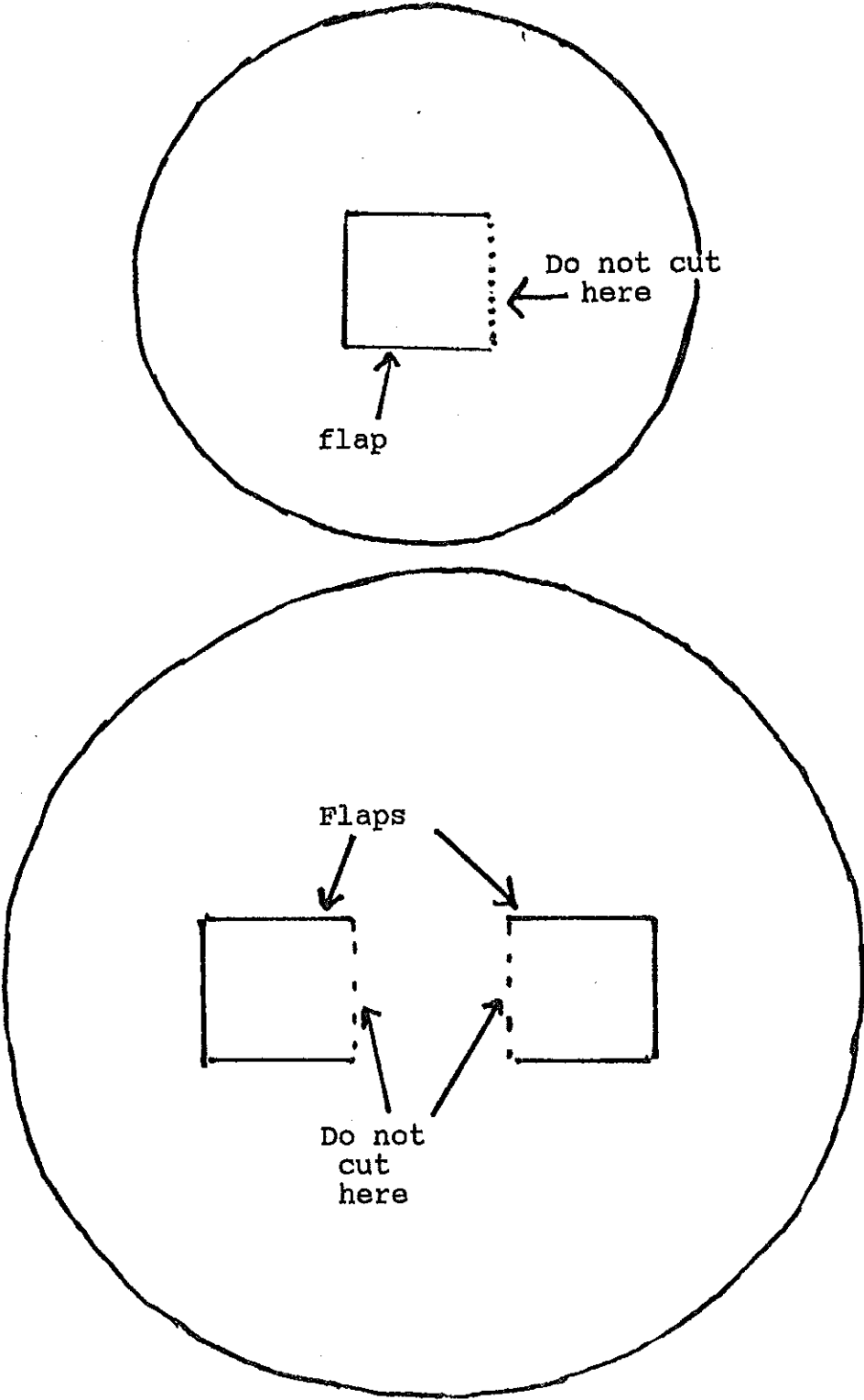

PART B: Building a 2-chambered heart

1. Tape one of the small circles to the top of a large cup. Open the flap downward. Tape a small cup onto the circle top down as shown.

2. With scissors, punch a small hole in each end of the model as shown. Insert a short straw in each hole and add labels to the straws as shown in Figure 11.

Figure 11: Two Chambered Heart Model

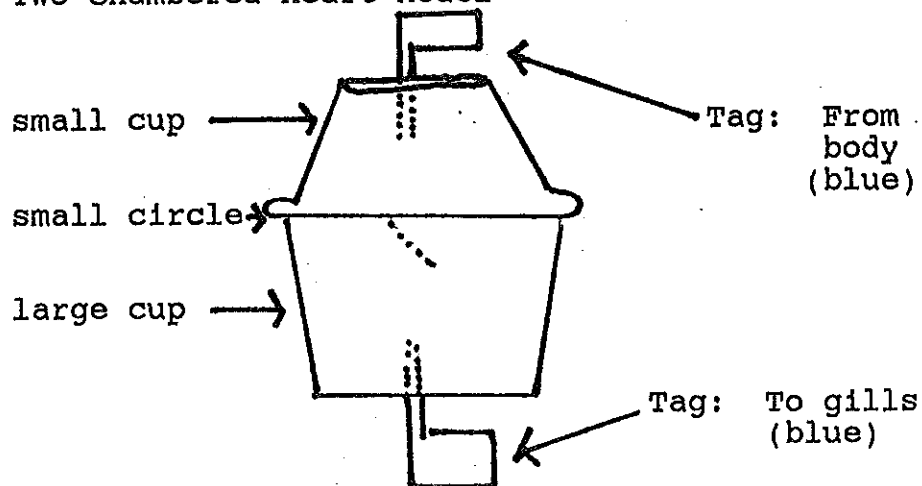

PART C: Building a 3-chambered heart

1. Tape the large circle to the top of a large cup. Open the flaps downward.

2. Tape two small cups onto the circle, tops down. With scissors, punch a hole in each top cup as shown. Punch another hole in the large circle in front of the cups.

3. Insert a short straw in each top cup and a long straw in the hole through the circle. Add labels as shown in Figure 12.

Figure 12: Three Chambered Heart Model

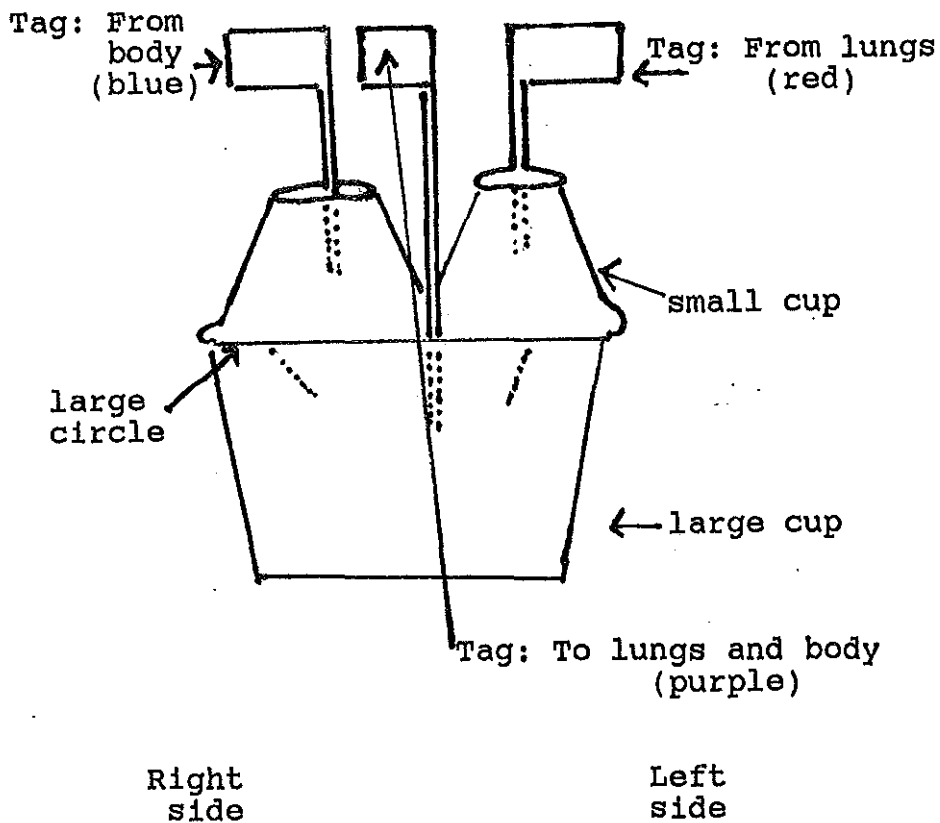

PART D: Building a 4-chambered heart

1. Tape a small circle to the top of two large cups. Open the flaps downward. Tape a small cup onto each circle as shown in Figure 13.

2. Punch a hole in the top of each top chamber (small cup) and insert a short straw in each hole.

3. Punch a hole in the circle in front of each top chamber and insert a long straw into each bottom chamber (large cup).

4. Tape the two sides of the heart model together. Add labels to the straws as shown in Figure 13.

Figure 13: Four chambered Heart Model

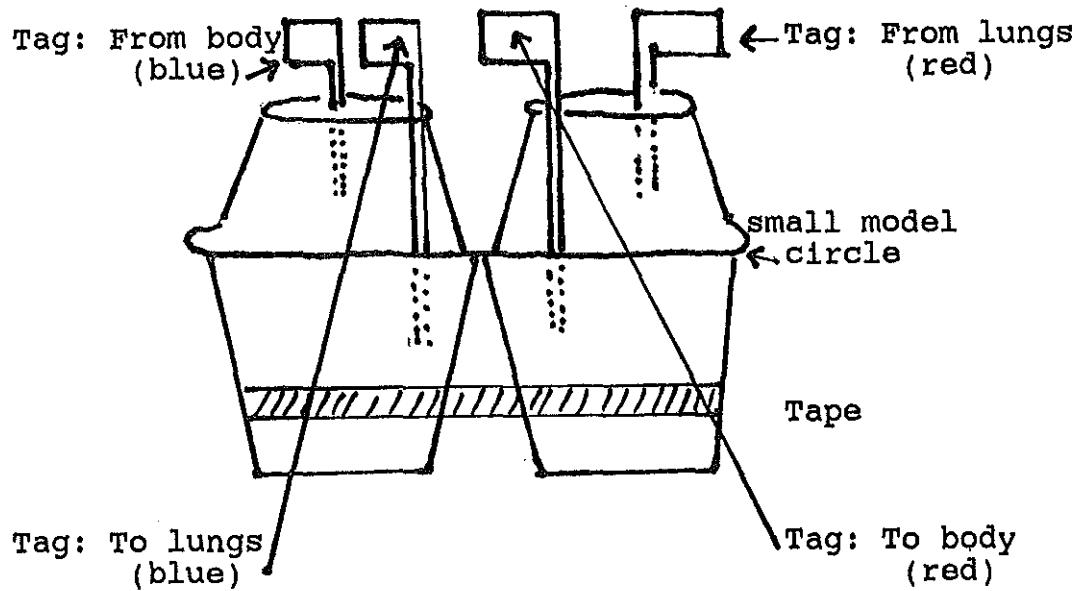

Examine the models. What do the flaps in the circles between top and bottom chambers represent? What do they do?

Circle the best answer in the following questions:

1. In a two chambered heart blood in the top chamber is: oxygenated; deoxygenated; mixed
2. In a two chambered heart blood in the bottom chamber is: oxygenated; deoxygenated; mixed
3. In the 3 chambered heart, blood in the top chambers is: oxygenated in one, deoxygenated in the other; mixed in both; deoxygenated in both; oxygenated in both
4. In the 3 chambered heart, blood in the lower chamber is: oxygenated; deoxygenated; mixed
5. In the 4 chambered heart blood in the top chambers is: oxygenated in both; deoxygenated in both; oxygenated in one and deoxygenated in the other

6. In the lower chambers of the 4 chambered heart, blood is: oxygenated in both; deoxygenated in both; oxygenated in one and deoxygenated in the other

TEACHER DISCUSSION: Vertebrates have hearts that vary in structure from 2 to 4 chambers. The upper chamber, the atrium, is a receiving chamber. The lower chamber, the ventricle, is a pumping chamber. Fish have 2 chambered hearts, amphibians and reptiles have a three chambered heart and birds and mammals have a 4 chambered heart.

Arteries carry blood away from the heart and may carry oxygenated or mixed blood. Veins carry blood toward the heart and may carry deoxygenated or mixed blood. Animals with 2 or 3 chambered hearts have mixed blood in their ventricles while animals with 4 chambered hearts have oxygenated blood in one ventricle and deoxygenated blood in the other. There is an advantage to 4 chambered hearts in that blood leaving the ventricle to the body carries only oxygenated blood and is more efficient in providing the body with oxygen.

(Kaskel et al., 1985, p. 78)

Activity #27 Keeping Warm With a Coat of Down

OBJECTIVE: To observe animal adaptations to their environment

SCIENCE PROCESS SKILLS: observation, inference

SCIENCE CONCEPTS: adaptation

MATERIALS: 2 small plastic bags, 2 lab thermometers, sheet of newspaper, scissors, clay, ice, plastic container such as a plastic milk bottle, waterproof tape such as duct tape

PREPARATION TIME: 30 minutes

TEACHER PROCEDURE:

1. Be sure that students are familiar with reading a thermometer. You may want to practice with ice water and warm water in a jar to insure accurate thermometer readings.

2. When inserting thermometers into the clay balls, be sure to take care students do not push too hard and break the thermometer. Also be careful to use only alcohol thermometers as mercury thermometers are a safety hazard.

3. Be sure students place an adequate layer of newspapers into the bag to provide insulation.

STUDENT PROCEDURE:

1. Shape a solid ball of clay. It should have no holes for air. Put it in one plastic bag.

2. Cut newspaper into small pieces or make loose wads to fill the other plastic bag. Do NOT pack the paper

tightly, but leave it to be "fluffy". This bag will be like a coat filled with feathers. There is air space between feathers of a bird.

3. Make sure the two thermometers read the same in the same place by reading both of them in the same part of the room. Stick the bulb of one thermometer into the middle of the solid ball of clay. Stick the bulb of the other thermometer into the middle of the "feathers". Seal each bag tightly with tape.

4. Stand the two bags into a large container. Tape them to the bottom of the container. Add ice water until the bags are about two thirds covered. Check the temperature of each bag each 15 minutes for 45 minutes. Compare the temperature of each bag. Record your observations.

TABLE I: Temperatures of Prepared Bags

	Bag with Clay	Bag with "feathers"
Starting temp.		
Temp. after 15 minutes		
Temp. after 30 minutes		
Temp. after 45 minutes		

Conclusions:

1. Which bag had the lowest temperature after 15 minutes? after 30 minutes? after 45 minutes?

2. Why do you think the bag with the paper "feathers" stayed warmer than the one without the "feathers"?

3. How is the bag filled with newspapers like a coat filled with feathers?

TEACHER DISCUSSION: Down feathers are small, soft feathers with much air space between them. The air spaces act as an insulator and make these layers of feathers effective in holding heat longer. Trapped air in fur or feathers helps to keep an animal or bird warm as their environment changes temperature. Down feathers are one adaptation that animals have to help them adjust to their environment.

(Cooper et al., 1985, Level 4, p. 9)

Activity #28 Removing Minerals From Bones

OBJECTIVE: To observe the minerals present in bone

SCIENCE PROCESS SKILLS: experimentation, inference

SCIENCE CONCEPTS: structure of bone

MATERIALS: small bones (chicken), 2 jars, tape, vinegar, paper towels

PREPARATION TIME: 30 minutes

TEACHER PROCEDURE:

1. You may wish to use this as a demonstration. Be sure students have an opportunity to examine the bones before you treat them with vinegar and water.
2. Chicken bones, especially drumsticks, work well in this activity. Boil the bones and remove as much meat and tissue as possible.
3. When the bones are clean and dry, they are ready for the activity.

STUDENT PROCEDURE:

1. Take 2 chicken bones and make sure they fit into your jars. Try to bend the bones. DO NOT BREAK THEM.
2. Place one bone in a jar and fill with enough water to cover the bone. Label the jar.
3. Place the second bone in the other jar and cover with vinegar. Label the jar.

4. Let the jars stand in a safe place for a week. Then remove the bones from each jar.

5. Wash the bones and dry them. Try to bend each bone. Are they the same or different?

TEACHER DISCUSSION: Bones placed in water do not bend or change after one week. These bones serve as a control. Bones soaked in vinegar become rubbery and bend easily. Vinegar is a mild acid, acetic, that reacts to replace the minerals in bones, primarily calcium and phosphorus. The remaining tissue in bone is flexible.

You may want to point out that living bones are made of more than minerals. This living tissue gives bones flexibility and prevents them from breaking easily. (Cooper et al., 1985, Level 5, p. 71)

Activity #29 How Does the Foot Move?

OBJECTIVE: To observe how muscles and bones work together to cause movement

SCIENCE PROCESS SKILLS: using a scientific model

SCIENCE CONCEPTS: muscle contractions

MATERIALS: paper punch, scissors, string (two pieces), tape, metal fastener, cardboard

PREPARATION TIME: 1 hour

TEACHER PROCEDURE:

1. To save time, make copies of the foot parts A and B (Figure 14) for students. You may want to even punch the holes in part A.

2. The model works better if parts are then retraced and cut out of heavier paper or cardboard.

STUDENT PROCEDURE:

PART A: Making a Model of the Lower Leg and Foot

1. Trace onto cardboard parts A and B (Figure 14), including the letters and circles. Cut out your tracings.

Figure 14: Foot Model Pieces

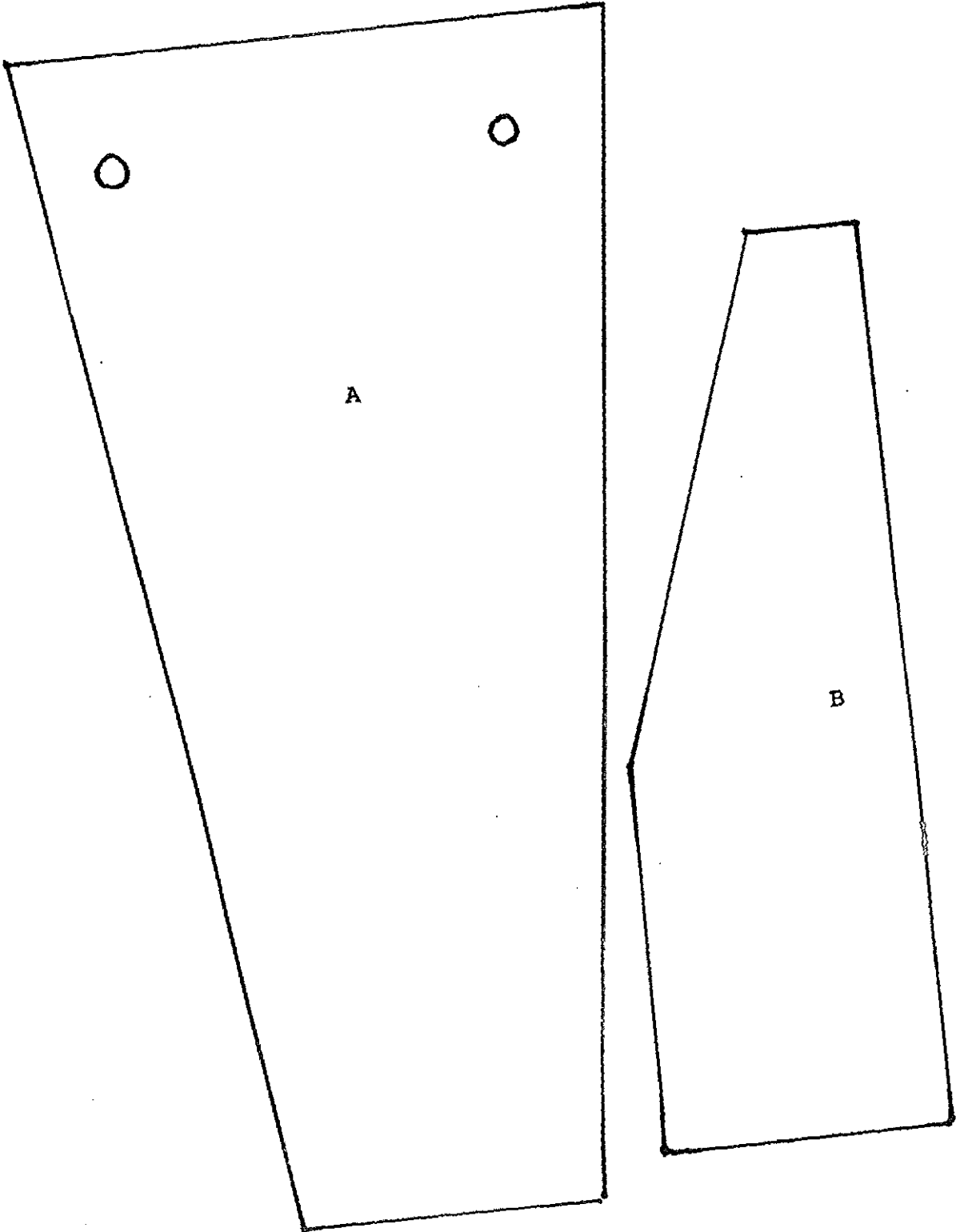

2. Punch holes in the piece A where the circles are marked.
3. Put the model together following these steps:
 - a. Place parts A and B together as shown in Figure 15. What is part A supposed to be in your body? What is part B supposed to be in your body?
 - b. Push the metal fastener into the paper where the "X" is shown. What part of your body is the fastener supposed to be?
 - c. Put two pieces of string through the holes and tape down the ends as shown in Figure 15. What are the strings supposed to be in your body?

Figure 15: Assembly of Foot Model

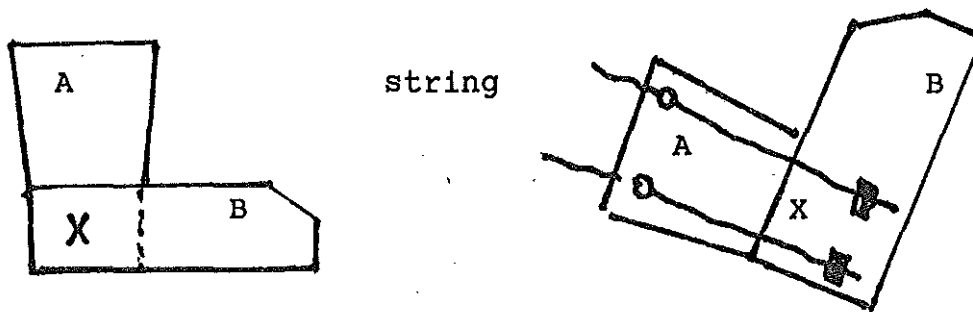

PART B: Using the Model

1. Holding your model with one hand, pull string 1 toward the back of your model with the other hand. Record in Table J what happens when string 1 is pulled.
2. Pull string 2 in the same way as you did string 1. Record in Table J what happens when string 2 is pulled.

TABLE J: Effects of Pulling Foot Model Strings

	Foot moves up or down	String 1 shortens or lengthens	String 2 shortens or lengthens
String 1 pulled			
String 2 pulled			

CONCLUSIONS:

1. How many muscles does it take to move your foot up and down?
2. When a string is shortened, is the "muscle" contracted or relaxed?
3. Are the muscles that move your foot located in your foot or lower leg?

TEACHER DISCUSSION: Muscles and bones work together to bring about movement. To move a bone, a muscle can only pull on the bone. Muscles cannot push. Because a muscle can only pull when contracted, it takes two muscles to move a bone back and forth. Those muscles are called an antagonistic pair of muscles. One muscle contracts or shortens to move the bone in one direction. To move the bone back in the opposite direction, another muscle must contract. When one muscle contracts, its antagonist must relax. The strings represent the muscles.

(Kaskel et al., 1985, p. 107)

Activity #30 How Does an Arm Move?

OBJECTIVE: To construct a model to demonstrate the action of muscles and tendons in movement

SCIENCE PROCESS SKILLS: using a scientific model

SCIENCE CONCEPTS: action of muscles and tendons

MATERIALS: cardboard pieces labeled "lower arm bones" and "upper arm bones", 2 rubber bands, 1 paper fastener, 4 pieces of string

PREPARATION TIME: 1 hour

TEACHER PROCEDURE:

1. To save time, you may want to prepare the lower and upper arm bone pieces. You will need a piece of cardboard approximately 20 cm x 28 cm (8.5 x 11 inches). Cut and label the bones as indicated in Figure 16. Be sure to label "bones" in plural in the lower arm. Use the tips of your fingers to draw in the hand part of the lower arm. Add the thumb, making it extended so the students will be able to tell in which direction they are moving the lower arm.

2. The average length of string students will use is approximately 33 cm. The size of rubber bands is not crucial. However, they must be large enough to fit between the holes in the upper and lower arm pieces. Although the models will work without the rubber bands, they help illustrate the muscle/tendon relationship in the movement of bones.

Figure 16: Arm Model Pieces

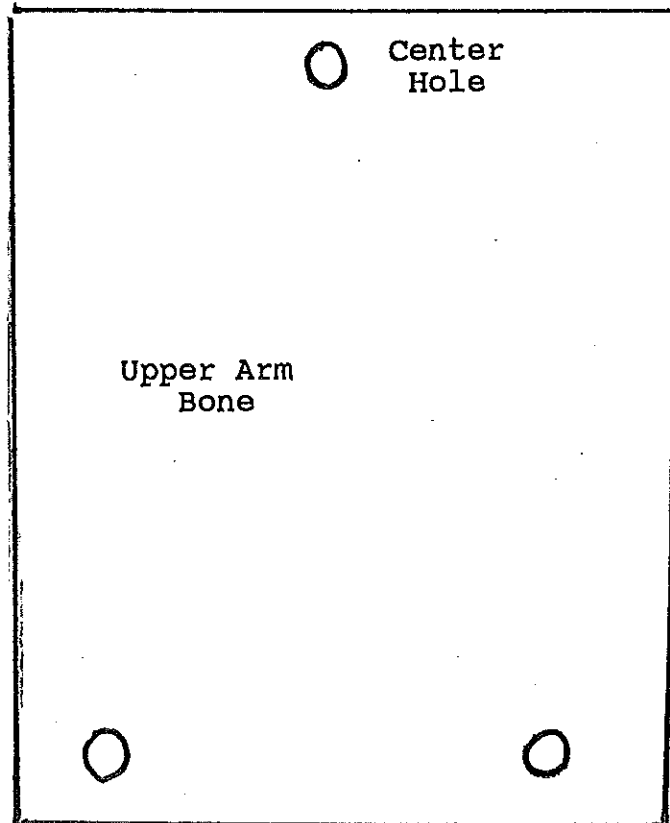
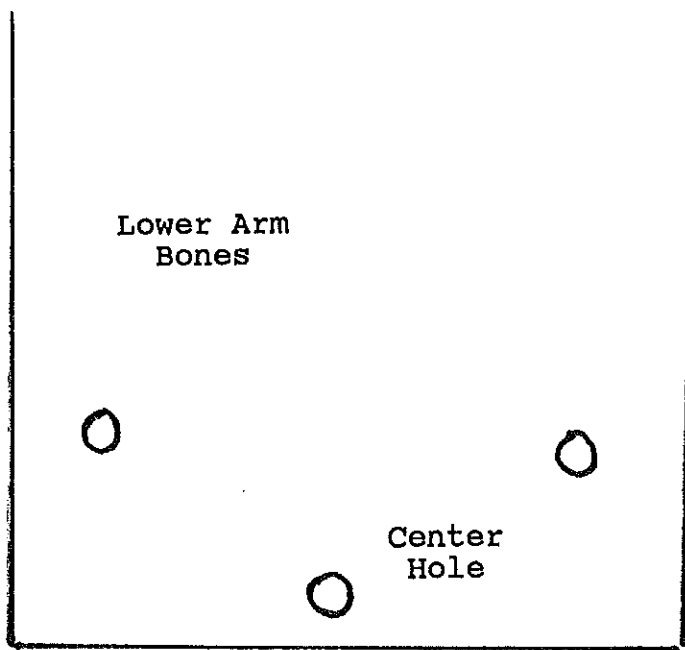

STUDENT PROCEDURE:

1. Join the upper and lower arm bones, as shown in Figure 17, by placing the paper fastener through the center holes. Spread the fastener to hold it.

2. Loop a piece of string through one end of a rubber band. Insert the string in hole 1. Tie the two ends of the string, making sure the string is loose. Loop a second string through the other end of the rubber band and insert in hole 2. While making sure the rubber band lies flat and unstretched, tie this string loosely at hole 2 (see Figure 17-Step Two). This is rubber band "A".

3. Repeat step 2 for holes 3 and 4, using the last two pieces of string and the second rubber band. This is rubber band "B". Your arm model should look like Step Three in Figure 17.

Figure 17: Arm Model Assembly

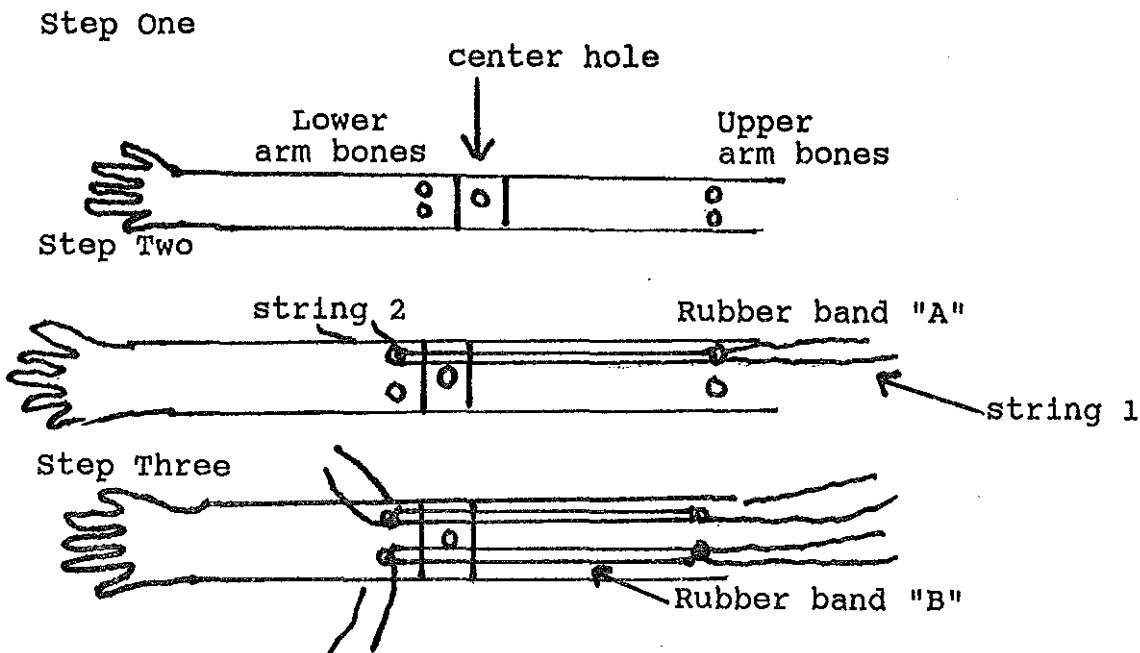

What body part does the paper fastener represent?

What do the rubber bands represent?

What do the strings represent?

4. Make sure the arm is straight. While one person holds the upper arm in position, have the other person pull the top part of rubber band "a". What happens?

Release the rubber band. What happened?

5. Repeat step 4 with rubber band "b" until the arm bones are back in their original position.

TEACHER DISCUSSION: Three structures, muscles, tendons and ligaments are important in the motion of joints between bones. Muscles work in antagonistic pairs to pull bones in opposing directions. Flexors are muscles which decrease the angle between bones such as the biceps of the upper arm that pull the lower arm closer to the upper arm. Extensors are muscles that increase the angle between bones such as the triceps of the upper arm that "straighten" the lower arm away from the upper arm. The rubber bands of the activity represent these extensor and flexor muscles. Rubber band "A" is a flexor while rubber band "B" acts as an extensor. Once the arm is flexed it will not move unless acted upon by the extensor muscle. (Thus when rubber band "A" is pulled the arm flexes upward and when it let go no motion occurs.)

Tendons are relatively inelastic bands of connective tissue that connect muscles to bones. The strings in this model represent the tendons. As these pull on the bones the

tendons also pull. Ligaments are bands of connective tissue that attach bones to bones. The paper fastener represents the elbow joint that is held together by ligaments.

(Ramsey et al., 1986, p. 95)

Activity #31 How Do Our Senses Help Balance Our Body?

OBJECTIVE: To observe how body senses affect balance

SCIENCE PROCESS SKILLS: collecting data, inference, drawing conclusions

SCIENCE CONCEPTS: equilibrium maintenance

MATERIALS: chalk, metric ruler, masking tape, watch with a second hand, a broom handle

PREPARATION TIME: 30 minutes

TEACHER PROCEDURE:

1. You may want students to work in groups of three or four. Have each group rotate sequence of activities to reduce the need for equipment.

2. You may want to review with students how to keep time with a second hand or stop watch.

STUDENT PROCEDURE:

1. With a piece of chalk draw a square on the floor or a piece of cardboard. The square should measure 15 cm on each side. Stand inside the square while balancing on the toes of your right foot. You may not use your arms to balance yourself. Have your partner record the time you can keep your balance. Stop timing when you lose your balance or your toes touch the lines of the square. Record your data in Table K.

2. Repeat this activity, using the following changes:
 - a. stand on toes of the left foot
 - b. stand on toes of one foot with eyes closed
 - c. stand on toes of one foot with head resting on the same shoulder
 - d. stand on toes of one foot with head resting on the opposite shoulder. Record your time for each activity.

TABLE K: The Effect of Certain Variables on Balance

Variable	Balance Time (in seconds)
Right foot	-----
Left foot	-----
Eyes closed	-----
Head on same shoulder	-----
Head on opposite shoulder	-----

3. Fasten a broom handle to the floor with masking tape so that it will not roll. Try to walk the length of the broom handle without falling off. Do not use your arms for balance. If you do fall off, measure the length in cm, that you walked on the handle. If you walked the entire handle without falling off, measure its length and record.

4. Repeat the activity, using the following changes:
 - a. use your arms to balance yourself
 - b. keep your hands clasped behind your back
 - c. use your arms but close your eyes

d. use your arms, but put your head on the same shoulder. Record the distance you walk each time in Table L.

TABLE L: The Effects of Eyes and Ears on Balance

Variable	Distance Walked (in cm)
Arms not used	
Arms used	
Arms behind back	
Eyes closed	
Head on shoulder	

TEACHER DISCUSSION: For controlled body movement, we depend on the brain, eyes, and ears. Although the major organ of equilibrium is located in the inner ear, the eyes and receptors in the skeletal muscles also help to maintain balance. Tilting the head varies the role of the equilibrium mechanism of the ear. The role of the eyes is such that students will not be able to maintain balance for as long a time with their eyes closed as with eyes open. The role of position receptors in the skeletal muscles is tested by tilting the head and keeping arms from participating in the balancing role.

Both cerebral hemispheres (sides of the brain) participate in basic functions such as receiving and analyzing sensory information, memory, and controlling skeletal muscles on the opposite side of the body. However

for most people, one side acts as a dominant hemisphere for certain functions. The role of the dominant side of the brain is tested by alternating balance on right and left feet. For most people, the dominant side of the brain corresponds to the dominant hand, eye and foot. Strangely the nondominant side of the brain seems to function in orientation of the body in space. In some individuals there is no clear cut dominant side of the brain.

(Barr, 1986, p. 99)

Activity #32 Biological Communities

OBJECTIVE: To examine a biological community

SCIENCE PROCESS SKILLS: observation, collecting data

SCIENCE CONCEPTS: abiotic and biotic factors of a community, food relationships

MATERIALS: plastic spoon, soil sample, small jar with cover, newspaper, hand lens, shallow pan or tray (a milk carton with one long side removed can be substituted)

PREPARATION TIME: 45 minutes

TEACHER PROCEDURE:

1. It will probably be easiest for you to make soil sample collections yourself. Gather samples from a variety such as forest, corner lot, railroad embankment, suburban lawn (label the samples as you collect). Place the samples in plastic sandwich bags. Be sure the soil sample includes top and lower levels of soil for 2-3 inches. With a trowel, dig a sample about 2 inches deep and 3-4 inches on a side. Be sure to include vegetation found on the soil as it is most important. You may want to allow students to gather their own samples. Again be sure that they gather from a variety of communities.

2. If you are unfamiliar with common specimens a few field guides, such as insects, might be kept available for reference. Do not be too concerned with correct biological

identification but rather the role of the organism in the community. Common identifications will be sufficient.

3. You may want to allow students to work on the floor or large tables as their "lab area". Urge them to be patient observers because it may take several seconds for them to locate any organisms.

STUDENT PROCEDURE:

1. Place several sheets of newspaper on your desk or lab area.

2. Place your soil sample on the newspaper. Your soil sample represents a community. Use a spoon to help break up the soil into smaller clumps. Look carefully with a hand lens for any small organisms.

3. A technique called flotation method may be used to help separate consumers from the soil. Place part of your soil into a shallow pan. Add water until the soil is covered by a layer of water. Break up any clumps of soil.

4. Wait several minutes and then carefully examine the water's surface for small organisms. Consumers may be collected and placed into jars. Use your spoon to skim the organisms off the water.

5. Use Table M to record the name and number of each type of organism seen in your sample. Use the key provided to help identify the organisms in your community.

TABLE M: Organisms in Sample Community

ORGANISMS IN A COMMUNITY

Name of organism	Number of these seen
------------------	----------------------

ROLE OF ORGANISMS

Name of Producer organism	Number seen
---------------------------	-------------

Name of Consumer organism	Number seen
---------------------------	-------------

1. Were there the same number of producers and consumers in your sample?
2. What kind of organisms, producers or consumers, were there in greater number?
3. Why must there be producers in all communities?
4. Were the organisms in all samples exactly the same?
Why do you think this might be ?

TEACHER DISCUSSION: A biological community consists of all the organisms in a given area. Remember that means plants and animals. Those organisms that are capable of producing food from inorganic sources, in other words organisms capable of photosynthesis, are called producers.

Those organisms that rely on producers for a source of food are called consumers. Consumers may be first order consumers that rely directly on producers, such as a cow

relies on grass, or they may be second order consumers that eat other consumers, such as a fox eating a rabbit.

All communities must contain a greater number of producers than consumers. The relationship of producer to consumer to further consumer forms a food chain. A food chain is a possible list of organisms that transfer energy from its primary source to its ending. Since some energy is lost at each transfer, the number of producers must be greater than each successive step in the chain.

(Kaskel et al., 1986, p. 1)

Activity #33 Life in a Square Meter Community

OBJECTIVE: To observe and record members of a community and their interrelationship

SCIENCE PROCESS SKILLS: observation, data collection, inference

SCIENCE CONCEPTS: biotic communities, food webs, food relationships, abiotic factors

MATERIALS: (per team of 4 students) one ball string, 4 pieces graph paper, hand lens, 6 large plastic bags, meter stick, newspaper, small shovel or trowel, large nails or tent stakes, pencil

PREPARATION TIME: 30 minutes

TEACHER PREPARATION:

1. The extent to which you want to carry this activity depends on the abilities of your students. For example, you may want to do simple observations and no collecting of specimens. You may want to simplify the data tables for younger students.

2. You may want to mark off the sites in advance for your students or pick one or two sites to study with the entire class.

3. Try to direct students to a variety of sites. Plant specimens are the key to variety, so choose sites that have different vegetation, for example, under a large tree, a weeded area, a grassy lawn area. You should check the

possible sites in advance to spot possible hazards such as large anthills, plants with nettles, etc.

4. If you wish to collect a few plant specimens, place the leaves or plant between sheets of newspaper. Allow the plants to dry for 3-4 days in the newspaper. Place several books on top of the paper to aid in pressing the specimens. Specimens can then be glued to large sheets of paper or posterboard for display.

5. Disposable plastic trays such as meat and vegetables are packaged on by grocery stores are useful in place of newspaper to collect the soil samples.

STUDENT PROCEDURE:

1. Using a meter stick, string, and four stakes, mark off a square-meter site in an area near your school. Make a drawing of your site on graph paper showing major features such as areas covered by leaves, rocks, and small plants. (Optional) Make the following observations of your site.

TYPE OF SOIL

2. Observe the soil for the following characteristics: color, smell, moisture: dry, wet, moist.

TABLE M: Characteristics of Soil

Color

Odor

Moisture

OBSERVATIONS OF PLANTS

3. Record the number of the following plant types in your data table:

- a. trees
- b. bushes
- c. grasses, ferns, weeds with soft stems

TABLE N: Plants in the Square-Meter Community

	Trees	Shrubs	Soft Plants
<u>Number</u>			

OBSERVATION OF ANIMALS

4. If present, collect a sample of fallen leaves and place in a plastic bag for later observations.

5. With your shovel, dig a square of soil from your site. Make the sample about 2 inches deep and place the soil carefully on a piece of newspaper. Dig two or three other places in your site. Place them in plastic bags and label sample A, sample B, sample C.

6. In the classroom, observe each soil sample and fallen leaf sample for animals. Place each sample on a piece of newspaper and carefully sort through it with a pencil. You may need a hand lens to observe the animals. Record the kind and number of the following types of animals:

- a. without legs
- b. with 2 pair of legs
- c. with 3 pairs of legs
- d. with more than 3 pair of legs

TABLE O: Animals in the Square-Meter Community

	Number of Animals			
	No Legs	2 pair legs	3 pair legs	More than 3 pair legs
leaf sample				
soil sample A				
soil sample B				
soil sample C				

1. What type of plants were most numerous in your community? What type of animal is most abundant?
2. How do you think the color, odor and moisture in the soil would affect the plants living there? How would it affect the animals living there?

TEACHER DISCUSSION: Living things are in a state of constant interaction with each other and their environment. Abiotic factors of the environment are those non-living factors such as soil type, sunlight, rainfall, minerals, temperature. Organisms inhabiting the soil are more diverse and numerous per given area than organisms on top of the soil. The structure and chemistry of the soil affect the

type and number of organisms found there. Darker soil, especially with an "earthy" odor indicates the presence of organic matter in the soil. Organic matter serves as food for many organisms and therefore supports a greater number and variety of organisms. Moisture content is also important in determining which type and number of organisms can be supported.

The number and kind of plants is an important determinant of the types and numbers of animals that live in a site. Remember that plants are producers and all animals are consumers. Expect to find more plants in soil with great organic content and moisture. With greater number of producers, expect to find greater number and variety of consumers.

(Kaskel et al., 1986, p. 3)

Activity #34 Different Water Environments

OBJECTIVE: To compare water environments and their effects on the community

SCIENCE PROCESS SKILLS: experimentation, drawing a conclusion

SCIENCE CONCEPTS: interrelationship between abiotic and biotic elements of a community

MATERIALS: 12 beans, dish, 6 paper cups of soil, 2 glasses, iodine free salt, teaspoon, paper towels, labels, pencil

PREPARATION TIME: 45 minutes

TEACHER PROCEDURE:

1. This is an easy demonstration in which students can help.

2. Soak 12 beans for each group in water for an hour or so before activity (you will sprout more beans than are needed to ensure at least 6 healthy plants are available). Plant at least one seed in each cup of soil. Either plant the beans yourself and allow them to sprout fully before you begin the activity or allow students to plant and sprout the beans themselves. It is important that students start with healthy seedlings so they can observe the change in the seedlings.

3. Be sure that the only variable in this experiment is the water given the plants. Plants should be in the same amount of light, same temperature, same soil. Be sure

students recognize that all conditions of growth are the same except for the variable of water.

STUDENT PROCEDURE:

1. When the six beans sprout, label three cups "Salt Water" and three cups "Fresh Water."

2. For "Fresh Water" get a glass of water from the faucet. For "Salt Water", mix a teaspoon of salt into one glass of tap water.

3. Water all plants every other day with water that matches their label. Be sure that all plants receive the same amount of water on the same day. Why is that important? Place the plants in a sunny place in the same room. Why is it important to see that all plants get the same amount of sunlight? Why is it important that all the plants be kept at the same temperature?

4. Observe your plants daily and keep a record of their growth. Which plants do you think will grow better? Observe your plants for about 10 days.

TEACHER DISCUSSION: Plants and animals must be adapted to their environment to survive. An adaptation is a modification of an organism in structure or function that allows it to adjust to a condition or environment. Bean plants are not adapted to growing in salt water, therefore these plants will probably stop growing or die. An abiotic

factor in the environment such as salt water may prevent or limit the growth or survival of an organism.

The salt in the water will cause osmosis to act in such a way that water will move out of the roots and into the soil rather than into the roots. Plants that live near the ocean or marsh must be adapted to the salt water.

(Cooper et al., 1985, Level 4, p. 23)

#35 Using Solar Energy to Clean Water

OBJECTIVE: To observe how water can be recycled

SCIENCE PROCESS SKILLS: experimentation, inference

SCIENCE CONCEPTS: distillation

MATERIALS: large dishpan, plastic food wrap, 2 small rocks, metric ruler, masking tape, muddy water, clear glass or baby food jar (height of jar must be less than depth of dishpan)

PREPARATION TIME: 30 minutes

TEACHER PREPARATION:

1. This is a good demonstration. It can be used to demonstrate water distillation or as a model for the water cycle.
2. The jar needs to be weighted down in the dish pan so that it does not float. Any object that weights it down will work. It does not have to be a rock.
3. Be sure there is an airspace of an inch or two between the water level in the pan and the plastic wrap. The rock outside the wrap and above the jar is a weight to cause the plastic wrap to funnel condensed water into the jar. Again any weight will work as well as a rock. Be sure the wrap dips toward the jar but does not touch it keeping the water from entering the jar.
4. The success of this activity depends on the heat of the sun to cause evaporation. To ensure enough heat, you may want to use a student desk lamp to provide a steady,

reliable source of heat. Be sure that you do not let the lamp get too close to the plastic wrap as it may melt or sag into the muddy water. Be sure to tell students the lamp represents the sun.

STUDENT PROCEDURE:

1. Fill a dishpan with muddy water until the water is three centimeters deep.
2. Put a rock inside the jar and place the jar in the middle of the dishpan.
3. Cover the dishpan with plastic food wrap. Pull the wrap tight over the pan and tape the edges to the pan.
4. Put a small rock on top of the plastic. Make sure the rock is above the jar. Do not let the rock touch the jar (see Figure 18).

Figure 18: Assembly of Dishpan and Water

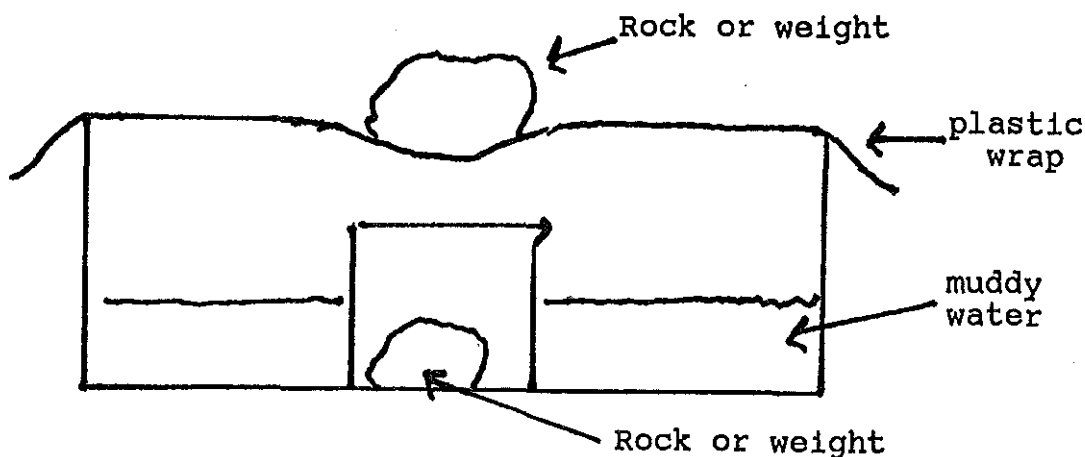

5. Place the pan in a warm, sunny place. After several hours, observe the jar. What do you see?

6. After one or two days, remove the plastic wrap and measure the water collected in the jar. Put the water back in the jar and replace the plastic wrap. Allow the pan to sit for 2 more days, then measure the water in the jar again.

7. After 4 or 5 days, measure the depth of water in the pan.

TABLE P: Change in Water Levels

	Day 2	Day 4	Day 5
Depth of water in jar			

Depth of water in pan			

1. How does the appearance of the water in the jar compare with the water in the dishpan?

2. From where did the water in the jar come? What makes you think this? What proof do you have?

TEACHER DISCUSSION: The reverse processes of evaporation and condensation will cause the water to collect in the jar. As water evaporates from the dishpan, it will condensate on the plastic and run into the jar. Notice that mud dissolved in the water will not collect in the jar. This process can be used to clean water and make it usable. Through this

distillation process, ocean water can be converted into water used for drinking, farming and industry.

(Trowbridge et al., 1980, p. 45)

Activity #36 How Do Decomposers Decay Organisms?

OBJECTIVE: To observe the role of decomposers in the environment

SCIENCE PROCESS SKILLS: hypothesis, inference

SCIENCE CONCEPTS: food relationships

MATERIALS: 2 banana slices, 2 plastic sandwich bags, yeast

PREPARATION TIME: 20 minutes

TEACHER PROCEDURE:

1. Use of zip lock sandwich bags is easiest. The yeast can be purchased from the grocery store as dry yeast. No preparation of the yeast is needed. Use yeast directly from the package.

2. Any moist fruit can be used in the place of bananas. If you use bananas, start with firm slightly unripe bananas.

STUDENT PROCEDURE:

1. Put a slice of banana inside each of 2 plastic bags. Sprinkle some yeast on one slice. Do not put anything on the other slice.

2. Close both bags. Label the bag with yeast "Yeast".

3. Look at both bags each day for 5 days. What difference do you see between the banana with yeast and the banana without yeast? How is the banana with yeast changing? What do you think is causing this change?

TEACHER DISCUSSION: Decomposers are organisms which convert dead organic matter into simpler substances. In other words, decomposers break down dead plants and animals for energy. They are important in the environment because they recycle nutrients. For example, they give off carbon dioxide which is in turn used by plants for photosynthesis.

Yeast is a fungi. Other examples of fungi include mushrooms, mold, mildew. Fungi serve as important decomposers in the environment.

(Abruscato et al., 1986, Level 4, p. T311)

Activity #37 How Do Oil Spills Affect the Environment?

OBJECTIVE: To observe the effect of pollution on the environment

SCIENCE PROCESS SKILLS: experimentation, inference

SCIENCE CONCEPTS: pollution

MATERIALS: two feathers, motor oil, mineral oil, water, brush, newspaper, small pan or tray, (optional) hand lens, small paint brushes

PREPARATION TIME: 20 minutes

TEACHER PROCEDURE:

1. Feathers such as from a feather duster work well. It may be good to try a variety of feather types such as the heavy, sturdy contour feathers which cover the outside of a bird and the fluffy, soft down feathers that lay against the bird to provide insulation. To avoid a cleanup in the classroom, motor oil can be applied to the feathers with a small brush or popsicle stick.

2. Another option to try would include trying to clean the feathers with soap after the activity. This would give students an experience with pollution cleanup activities.

STUDENT PROCEDURE:

1. Spread newspaper on your desk. Look at the bird feather. You may want to use a hand lens. Notice its

appearance and weight. Try to float a feather on a pan of water. How does the feather act in the water?

2. Coat the feather with motor oil. How does the oil change the feather? Try to float the coated feather on the pan of water. How does the feather act? How would this affect a live bird?

3. Using water, mineral oil, and a brush, try to clean the motor oil off the feather. What effect did your cleaning have on the feather?

TEACHER DISCUSSION: Feathers of birds provide not only contour and shaping for flight, they also are coated with a light waterproof oil to give the bird buoyancy in the water. Down feathers, the fluffy, soft feathers next to the skin, provide insulation for the bird. Motor oil destroys the insulating properties of feathers leaving a bird to suffer from extremes in temperature. In attempting to clean their feathers, birds swallow the oil and suffer from its toxic effects.

As an extension, you may want to explore the use of detergents to clean up oil. Detergents emulsify oil, meaning they break the oil into tiny droplets and then coat the droplets so they will not cling together.

EXTENSION:

1. Fill a bowl and place one drop of oil in the center of the bowl. How does the oil look?

2. Drop by drop, add detergent to the center of the spot of oil and observe any changes. What happened to the spot of oil when the detergent dropped on it? Count the number of drops of detergent added before any change can be seen. How many drops of detergent did it take for there to be an observable change in the oil?

3. Repeat steps 1 and 2 trying different detergents to see if the results vary. Try to clean the feather used in the activity.

(Abruscato et al., 1986, Level 4, p. 329)

Activity #38 How Does Pollution Affect Seeds?

OBJECTIVE: To compare the effect of detergents on seed germination

SCIENCE PROCESS SKILLS: hypothesis, experimentation, drawing a conclusion

SCIENCE CONCEPTS: effect of pollution

MATERIALS: 2 beakers or jars, labels, liquid detergent, paper towels, 40 bean seeds, 2 small plastic bags, masking tape, water

PREPARATION TIME: 30 minutes

TEACHER PROCEDURE:

1. Dried lima beans from the grocery store work well in this activity.
2. Household detergent for washing dishes is suitable. Dilute one part detergent with two parts water for the detergent solution. Full strength detergent is not needed.

STUDENT PROCEDURE:

1. Place 20 beans in each of the beakers. Add tap water to one beaker until the seeds are completely covered. Add detergent solution to the other beaker until the seeds are covered.
2. Label each beaker with your name and kind of solution covering the beans, "water" or "detergent".

3. Let the seeds sit overnight, then pour off the liquid. Rinse the seeds soaked in detergent with water.

4. Place each set of seeds between two layers of paper towels, moisten the towels with water and slide the towels with the seeds into plastic bags. Close the top of the bags. Keep the bags laying flat at all times. Label each bag with your name and type of solution in which the seeds were soaked.

5. Observe the seeds in each bag after 48 hours. Look for signs of sprouting. Sprouting seeds will show a small root beginning to appear. Count the number of seeds sprouting in each bag and record the number.

TABLE Q: Seeds Sprouting

SEEDS SOAKED IN	Number of seeds used	Number of seeds sprouting
Water		
Detergent		

1. Which seeds showed the most sprouting?
2. How could you test if large or small amounts of detergent are both as harmful to sprouting seeds?
3. How could you determine if water containing detergents is harmful to plants?

TEACHER DISCUSSION: Detergent is a pollutant. The seeds soaked in detergent should show little or no signs of germinating. Germination will show as the emergence of a

root from the seed. Varying strengths of detergent could be tested by changing the amount of detergent added to the detergent solution. For example, you could try a one part detergent to two parts water, a one part detergent to three parts water and a one part detergent to four parts water for the detergent solution.

To test the effect of detergent on plants, two sets of identical plants such as coleus should be used. Plants should be watered with either tapwater or a detergent solution such as the one used to soak the seeds. Be sure plants receive the same amount of water and sunlight. Compare the plants after several days.

(Daniel & Kaskel, 1986, p. 177)

Activity #39 How Do Pollutants Change Water?

OBJECTIVE: to observe the effect of varying pollutants on water

SCIENCE PROCESS SKILLS: experimentation, drawing a conclusion

SCIENCE CONCEPTS: pollution in the environment

MATERIALS: 12 small jars with lids, masking tape, marking pen, large jar (1 liter), 11 different materials (soap, oil, pencil shavings, food scraps, etc.)

PREPARATION: 30 minutes

TEACHER PROCEDURE:

1. Baby food jars make suitable containers for this activity. Materials added to the jars are to simulate common pollutants, therefore use your imagination.

STUDENT PROCEDURE:

1. Put a small amount of each material in one of the 11 jars. Use masking tape to label the contents of each jar.

2. Fill the jars about 2/3 full of water. Fill the 12th jar with water only.

3. Close each jar. Observe and record the appearance of each jar each day for one week. Make a data table to record your observations.

4. After one week, open each jar. Smell and feel the contents. DO NOT TASTE. Wash your hands after feeling the contents of the jars.

5. Compare the contents of each jar with the "water only" jar. Record your observations.

6. Pour the contents of the first 11 jars into the large jar. Observe and smell the contents.

TEACHER DISCUSSION: The materials in the jars will undergo different changes depending on the original material. The large jar represent a river, lake or even the ocean as varying pollutants are added. Ask students how they would feel about using this water for cooking, drinking or even bathing.

(Trowbridge et al., 1980, p. 55)

Activity #40 Detecting Air Pollution

OBJECTIVE: To observe pollution in air

SCIENCE PROCESS SKILLS: observation, inference

SCIENCE CONCEPTS: air pollution

MATERIALS: 5 posterboard strips (approximately 10 x 25 cm),
scissors, transparent tape, hand lens, marking pen

PREPARATION TIME: 20 minutes

TEACHER PREPARATION:

1. It will save time if you cut the posterboard strips and cut the holes before the activity (see Figure 19). An alternative to the strip, especially for younger children, is to use a paper plate covered with a thin coat of petroleum jelly.

Figure 19: Pollution Strip

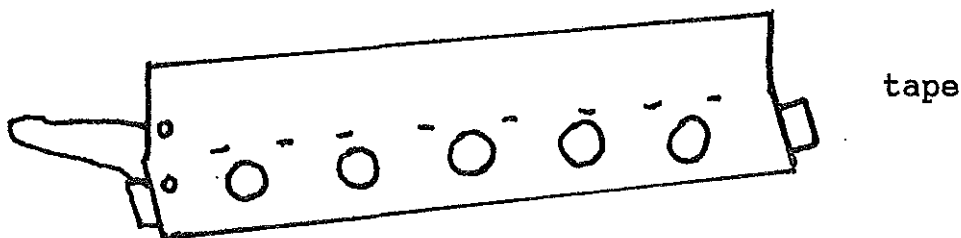

STUDENT PROCEDURE:

1. Fold your strip of posterboard in half lengthwise. Cut five nickel-size holes on one side of the strip.
2. Put transparent tape on the outside of the strip. The sticky side of the tape should show through each hole.

3. Fold the other half of the strip over the holes.
Tape the two halves together.
4. Hang the strips in five different places on different days. Include places both inside and outside. Label each strip with the location hung and the time of day. Open the strips and expose them to the air.
5. Collect and seal the strips at various intervals. Mark the time length of exposure on each strip.
6. In your classroom examine what has collected on the strip. Record your observations.

TABLE R: Pollution Collected

LOCATION	TOTAL TIME EXPOSED	DAYS EXPOSED	TYPE OF POLLUTION CAUGHT

1. Which strip picked up the most pollution?
2. During what time of the day was most pollution caught?
3. Where did the least amount of pollution occur?
4. What type of pollution occurs most often?

TEACHER DISCUSSION: The type and amount of pollution caught on the strips will vary with location, time of day, wind

conditions, etc. Let students make their own judgements
'based on their observations.

(Trowbridge et al., 1980, p. 51)

Results and Conclusions

Life Science for Elementary Teachers was field tested during the summer of 1990 as part of the curriculum of the Clay County Summer Inservice Institute. Enrollment consisted of 38 elementary teachers divided into two sections. Elementary teaching assignments of these participants ranged from kindergarten through sixth grade with the majority of participants teaching grades two through four.

Classes were conducted in four and one half hour sessions for fourteen days. During the sessions participants completed all forty activities of the curriculum. On the first day of the Institute a pretest was administered to all participants. On this pretest no participant scored at or above 80%. On the final day of the Institute a posttest was given with 84% of the participants achieving a score of 80% or better. All participants demonstrated notable improvement of their test scores.

Upon completion of the Institute, all participants completed an evaluation of the course. Response, in general, was very favorable. Weaknesses cited were "too many activities in one day" and "too many terms I will not use with elementary students." Most participants reported that they had gained confidence and enthusiasm for teaching

science. Frequent comments on evaluations cited "getting teachers involved with 'hands on' science" and "provided numerous ideas and projects the elementary teachers can actually use."

In reviewing the curriculum, it appears that the curriculum achieved its objectives of improving elementary teachers' competence in using science process skills and their confidence that they could use a laboratory approach to teaching science. At the beginning of the Institute, many participants expressed feelings of inadequacy in science knowledge though the majority used an activity centered approach in their classroom. Participants seemed in agreement that science is an essential part of elementary curriculum. They were eager, although occasionally apprehensive, to carry out the activities.

From both the instructors' and participants' point of view the most significant difficulty with the curriculum lay in time frame. Shortness of daily sessions, coupled with a four day week, required an average of six activities to be ongoing in a single day. Since several of the activities required one to two weeks to complete, it was necessary to set up as many as three activities a day while completing three or more activities from previous days. This hectic schedule caused the less confident participants to feel they did not have adequate time to absorb and comprehend the activity. They felt overlap from one activity to another was confusing.

This scheduling also created a difficult situation for the instructors, who found themselves preparing equipment and supplies for five to seven activities a day. Need to "keep on schedule" in setting up and completing activities allowed little flexibility and made it difficult to be sure that participants had adequate time to question instructions and procedures and review all activities. Participants would benefit from being provided a time frame for all activities in advance to provide preparation time for activities.

A second difficulty with the curriculum lay in the fact that some objectives were not completely met through activities or were not obviously tied to an activity. For example, one objective was to distinguish between invertebrate and vertebrate animals. There is no activity that directly addresses this objective, therefore some objectives were met through discussion with participants rather than laboratory experiences. Some participants felt they gained less usable information when it was not presented in an activity based format. Content associated with an activity was more relevant and meaningful to participants.

Several positive gains demonstrated the strengths of the curriculum. Notable improvement in use of science process skills especially observation, ability to make inferences, skill at data collection and organization were seen. During the first week time needed by participants to

observe and record data about an activity typically was five to ten minutes. By the end of the second week participants often insisted on thirty minutes or more to observe and record data for an activity. Participants learned how to organize and write an informal "lab report" including a problem statement or hypothesis, data, and a conclusion. Participants reported feeling more confident in observing and analyzing information. Laboratory reports showed improved organization, data collection and clarity in analyzing data.

An unexpected but welcome benefit from the program came in the form of increased awareness of scientific events in the everyday world. Participants initiated a "share time" at the beginning of each session in which they reported on newspaper or magazine articles or related material. This idea was so well received that it was expanded. Each participant brought at least one activity, publication, film or field trip to "share" with other participants. Information on sources of inexpensive and innovative science equipment suited to the elementary level was provided by participants. Suggestions for successful field trips or local resources were also exchanged. The culmination of this sharing was a field trip to the local zoological park with a tour and explanation by zoo personnel highlighting the educational program available. It was apparent that this exchange of information was an important addition to

the curriculum and should be an integral part of the curriculum.

Overall the curriculum met the objective of increasing elementary teachers confidence and competence using science process skills as well as science concepts. This increase of skill was substantiated by the 100% increase in scores on the posttest and by the favorable evaluation of the participants. Hopefully all the participants will carry into their classrooms the enthusiasm and confidence they displayed in the Institute.

References

- Abruscato, J., Fossaceca, J. W., Hassard, J., Peck, D. P. (1986). Holt Science Level 2, 3, 4. New York, NY: Holt Rhinehart, Winston.
- Audeh, G. R. (1982). A longitudinal study of science curriculum and practices in elementary schools in 10 states (1970-1980). Comprehensive Dissertation Index, 33, 181. (ERIC Document Reproduction Service No. 214 802)
- Barr, B. B. (1986). Addison-Wesley Life Science. Menlo Park, CA: Addison-Wesley.
- Bluhm, W. J. (1979). The effects of science process skill instruction on preservice elementary teachers' knowledge of, ability to use, and ability to sequence science process skills. Journal of Research in Science Teaching, 16(2), 427-432.
- Brown, W. R. (1977). The effect of process skill instruction on performance of preservice elementary teachers. Journal of Research in Science Teaching, 14(1), 83-87.
- Burke, M. A. (1980). Perceived needs of elementary science teachers. Science and Children, 17(5), 15-17.

- Campbell, R. L., & Okey, J. R. (1977). Influencing the planning of teachers with instruction in science process skills. Journal of Research in Science Teaching, 14(3), 231-234.
- Cooper, E. K., Blackwood, P. E., Boeschen, J. A., Giddings, M. E., & Carin, A. A. (1985). HBJ Science Level 4, 5. Orlando, FL: Harcourt, Brace, Jovanovich.
- Creager, J. G., Jantzen, P. G., & Mariner, J. L. (1985). Biology: Laboratory Manual with Study Skills Handbook. New York, NY: Macmillan.
- Daniel, L., & Kaskel, A. (1986). Focus on Life Science: A Learning Strategy for the Laboratory. Columbus, OH: Charles E. Merrill.
- Duschl, R. A. (1983). The elementary level science methods course: Breeding ground of apprehension toward science? Journal of Research in Science Teaching, 20(8), 745-754.
- Dykstra, D., Jr. (1987). Science education in elementary school: Some observations. Journal of Research in Science Teaching, 24(2), 179-182.
- Gallaher, J. J., & Yager, R. E. (1981). Science educators' perceptions of problems facing science education: A report of five surveys. Journal of Research in Science Teaching, 18(6), 505-514.
- Gates, R. W., Krockover, G. H., & Wiedermann, R. (1987). Elementary student teachers' perceptions of science in their classrooms: 1985-86. School Science and Mathematics, 87(8), 633-643.

- Gerlovich, J. A., Downs, G., & Magrane, G. (1981). How essential is science at the elementary level? Science and Children, 19(3), 22-24.
- Horn, J. G., & James, R. K. (1981). Where are we in elementary science education? School and Science Mathematics, 81(3), 205-215.
- Hounshell, P. G. (1987). Elementary science specialists: Definitely! Science and Children, 24(4), 20-21, 157.
- Jaus, H. H. (1975). The effects of integrated science process skill instruction of changing teacher achievement and planning practices. Journal of Research in Science Teaching, 12(4), 439-447.
- Kaskel, A., Humner, P.J., Jr., & Daniel, L. (1985). Biology Laboratory Experiences. Columbus, OH: Charles E. Merrill.
- Kaskel, A., Hummer, P. J., Jr., Kennedy, J. E., & Oram, R. F. (1986). Laboratory Biology: Investigating Living Systems. Columbus, OH: Charles E. Merrill.
- Mechling, K. R., & Oliver, D. L. (1983). What research says about elementary school science. Handbook IV. Project for promoting science among elementary school principals. Washington, DC: National Science Teachers Association.
- Morholt, E., Branwein, P. F., & Joseph, A. (1966). A Sourcebook for the Biological Sciences. New York, NY: Harcourt Brace Jovanovich.

National Science Teachers Association. (1982). Recommended Standards for the Preparation and Certification of Teachers of Science at the Elementary and Middle/Junior High School Levels. Steering Committee on Teacher Education. Washington, DC: Author.

Ramsey, W. L., Gabriel, L. A., McGuirk, J. R., Phillips, C. R., & Watenpaugh, F. M. (1986). Exercises and Investigations for Holt Life Science. New York, NY: Holt Rhinehart, Winston.

Riley, J. P., II. (1979). The influence of hands-on science process training on preservice teachers' acquisition of process skills and attitude toward science and science teaching. Journal of Research in Science Teaching, 16(5), 373-383.

Sheldon, D. S., & Halverson, D. (1981). Effects of a televised science inservice program of elementary teachers' confidence levels concerning science concepts and teaching strategies. School Science and Mathematics, 80(5), 405-411.

Shymansky, J. A., Romance, N., Yore, L. P. (1988). Journeys in Science Level 1, 3, 4. River Forest, ID: Laidlaw Educational Publishers.

Spooner, W. E., Szabo, S. E., & Simpson, R. D. (1982). The influence of a five-day teacher workshop on attitudes of elementary school teachers toward science and science teaching. Part II. School Science and Mathematics, 82(8), 629-636.

- Strawitz, B. M., & Malone, M. R. (1987). Preservice teachers' acquisition and retention of integrated science process skills: A comparison of teacher-directed and self-instructional strategies. Journal of Research in Science Teaching, 24(1), 53-60.
- Summerlin, L. R. (1979). Chemistry of Common Substances. Morristown, NJ: Silver Burdett Co.
- Trowbridge, L. W., Sund, R. B., Adams, D. K., & Hackett, J.A. (1980). Activity Book: Accent on Science. Columbus, OH: Charles E. Merrill.
- Wright, J. D. (1982). Teaching Science Today. Portland, ME: J. Weston Walsh.
- Yager, R. E. (1980). Analysis of Current Accomplishments and Needs in Science Education. Columbus, OH: Center for Science, Mathematics, and Environmental Education, College of Education, The Ohio State University. (ERIC Document Reproduction Service No. ED 209 106)
- Yager, R. E., & Yager, S. O. (1985). Changes in perceptions of science for third, seventh and eleventh grade students. Journal of Research in Science Teaching, 22(4), 347-358.
- Zeitler, W. R. (1981). The influence of the type of practice in acquiring process skills. Journal of Research in Science Teaching, 18(3), 189-197.