

Spring 2008

City of Stone Mountain

Emilie Arnold

Steven Busch

Stephanie Cherry

Parinya Chukaew

Emily Eigel

See next page for additional authors

Follow this and additional works at: https://scholarworks.gsu.edu/history_heritagepreservation



Part of the [Historic Preservation and Conservation Commons](#)

Recommended Citation

Arnold, Emilie; Busch, Steven; Cherry, Stephanie; Chukaew, Parinya; Eigel, Emily; Gadberry, Nancy; Haynes, Patrick; Johnson, Jeff; Miller, Charles; Mroczka, Chris; Sciscoe, Ingrid; Trope, Betty; and Wilson, Jared, "City of Stone Mountain" (2008). *Heritage Preservation Projects*. 41.

https://scholarworks.gsu.edu/history_heritagepreservation/41

This Design Guidelines is brought to you for free and open access by the Department of History at ScholarWorks @ Georgia State University. It has been accepted for inclusion in Heritage Preservation Projects by an authorized administrator of ScholarWorks @ Georgia State University. For more information, please contact scholarworks@gsu.edu.

Authors

Emilie Arnold, Steven Busch, Stephanie Cherry, Parinya Chukaew, Emily Eigel, Nancy Gadberry, Patrick Haynes, Jeff Johnson, Charles Miller, Chris Mroczka, Ingrid Sciscoe, Betty Trope, and Jared Wilson



City of Stone Mountain

Historic District Design Guidelines



City of Stone Mountain

Historic District Design Guidelines

**Prepared by
Preservation Planning Class**

**Heritage Preservation Graduate Program
Georgia State University**

April 2008

Acknowledgements

Project Team

Emilie Arnold	Jeff Johnson
Steven Busch	Charles Miller
Stephanie Cherry	Chris Mrocza
Parinya Chukaew	Ingrid Sciscoe
Emily Eigel	Betsy Trope
Nancy Gaberry	Jared Wilson
Patrick Haynes	

Instructors

Richard Laub

Director, Heritage Preservation Program
Georgia State University

Mary Ann Eaddy

Manager, Technical Services Unit
Historic Preservation Division
Georgia Department of Natural Resources

Special thanks to

Laura Drummond, Historic Preservation Specialist for the City of Stone Mountain, who initiated this project and has offered valuable insight and guidance throughout its preparation

The Stone Mountain Historic Preservation Commission, whose passion and dedication for protecting the city's historic character will continue to serve the City of Stone Mountain invaluable.

The City of Stone Mountain and residents of the Stone Mountain Historic District for opening their neighborhoods to us and making our time there an interesting and pleasurable experience.

Kathy Johnson, for invaluable and timely expertise and labor in assembling the final document.

Table of Contents

A. Purpose of Guidelines.....	1
B. Historic Overview.....	13
C. Stone Mountain HPC/COA Review Process	21
D. Historic District Character	29
E. Design Guidelines for Existing Buildings	59
F. Additions to Existing Buildings.....	91
G. Guidelines for New Construction	119
H. Community Landmark Buildings	145
I. Design Guidelines for Residential Landscapes.....	149
J. Streetscapes	157
K. Design Guidelines for Signage	163
L. Demolition or Relocation of Existing Structures	169
M. Stone Mountain Cemetery.....	173
N. Archeological Resources.....	181
O. Appendices	183

A. Basics of Historic Preservation

A.1 – Purpose of Guidelines

> A.1.a – General Purpose

The design guidelines presented here are meant to be used as a blueprint both for the rehabilitation or alteration of historic buildings, as well as the planning of new construction within the Stone Mountain Historic District. Property owners and residents, architects, builders and anyone else associated with the building trades, as well as the Stone Mountain Historic Preservation Commission (hereafter the “HPC”), should consult these guidelines when considering any construction project within the Stone Mountain Historic District. The guidelines present both recommended and not recommended courses of action. They are intended to simplify the task of planning a rehabilitation or new construction project within the district by enabling proactive planning, eliminating the need for costly and time-consuming design revisions and ensuring the timely approval of Certificates of Appropriateness. Design guidelines provide a means of protecting historic neighborhoods. Only through encouraging preservation and appropriate new construction in

the historic district can the physical characteristics and community ideals that make Stone Mountain unique be preserved. These guidelines can help one understand what makes historic Stone Mountain special; how the preservation of these qualities can benefit the community of Stone Mountain; and how each individual property or project within the area can be a valuable asset to the Stone Mountain Historic District.

A. Basics of Historic Preservation

> A.1.b – Secretary of the Interior’s Standards for Rehabilitation

The recommended courses of action found within these guidelines were formulated using the U.S. Secretary of the Interior’s Standards for Rehabilitation as base principles . The guidelines have been designed to apply the standards specifically to the Stone Mountain Historic District and potential preservation-related activities.

The Secretary of the Interior is responsible for oversight of all federal historic preservation programs. The Secretary’s Standards for Rehabilitation were initially developed in 1976 (Department of the Interior Regulations, 36 CFR 67) in order to determine the appropriateness of proposed work on specific properties listed on the National Register of Historic Places. Since that time, the Standards have expanded in influence and are today the set of over arching principles that governs the fundamental philosophy of historic preservation and the rehabilitation of historic properties in the United States. The Standards are intended to assist in the long-term preservation of a property’s significance through not only the preservation of historic materials and

details, but also through the encouragement of appropriate additions to historic buildings and new construction within historic neighborhoods, such as the Stone Mountain Historic District.

The Secretary of the Interior’s Standards for Rehabilitation are:

1. A property shall be used for its historic purpose or be placed in a new use that requires minimal change to the defining characteristics of the building and its site and environment.
2. The historic character of a property shall be retained and preserved. The removal of historic materials or alteration of features and spaces that characterize a property shall be avoided.
3. Each property shall be recognized as a physical record of its time, place, and use. Changes that create a false sense of historical development, such as adding conjectural features or architectural elements from other buildings, shall not be undertaken.
4. Most properties change over time; those changes that have acquired historic significance in their own right shall be retained and preserved.

A. Basics of Historic Preservation

5. Distinctive features, finishes, and construction techniques or examples of craftsmanship that characterize a historic property shall be preserved.
6. Deteriorated historic features shall be repaired rather than replaced. Where the severity of deterioration requires replacement of a distinctive feature, the new feature shall match the old in design, color, texture, and other visual qualities and, where possible, materials. Replacement of missing features shall be substantiated by documentary, physical, or pictorial evidence.
7. Chemical or physical treatments, such as sandblasting, that cause damage to historic materials shall not be used. The surface cleaning of structures, if appropriate, shall be undertaken using the gentlest means possible.
8. Significant archeological resources affected by a project shall be protected and preserved. If such resources must be disturbed, mitigation measures shall be undertaken.
9. New additions, exterior alterations, or related new construction shall not destroy historic materials that characterize the property. The new work shall be differentiated from the old and shall be compatible with the massing, size, scale, and architectural features to protect the historic integrity of the property and its environment.
10. New additions and adjacent or related new construction shall be undertaken in such a manner that if removed in the future, the essential form and integrity of the historic property and its environment would be unimpaired.

A. Basics of Historic Preservation

A.2 – Intro to Preservation

> A.2.a – Preservation in Stone Mountain

Chapter 5, Article II of the Stone Mountain Code of Ordinances (See Appendix) provides for the creation of a Historic Preservation Commission for the purpose of establishing “...a uniform procedure for use in providing for the protection, enhancement, perpetuation and use of places, districts, sites, buildings, structures, objects, landscape features and works of art having special historical, cultural or aesthetic interest or value.” A 2005 ordinance designates a historic district within the City of Stone Mountain. (For the text of the ordinance, see Section 0.2)

Design guidelines serve as the rules and procedures adopted by the HPC “...for the transaction of its business and for consideration of applications for designations and certificates of appropriateness.” Working together, these elements create a stewardship among present and future citizens for the protection of each generation’s unique footprint and contribution to the physical and cultural heritage of Stone Mountain.

> A.2.b – Why Preserve?

Historic properties are worthy of protection. Their preservation can stabilize neighborhoods, stimulate private investment, provide affordable housing, revitalize downtown activities, attract tourists and increase community pride.

Historic preservation programs enhance growth management by investing in the centers of older towns and cities and alleviating development pressure on the urban fringe, thereby reducing sprawl. Preservation has many diverse intentions and rewards, including strengthening of local economies, stabilization of property values, fostering civic beauty, enhancement of cultural tourism, and appreciation of local and national history.

While providing economic and aesthetic benefits, historic preservation has a public purpose that advances the education and welfare of citizens. By understanding the past, people can better define and interpret their own cultural identity and heritage, as well as establish a framework for public decisions regarding land use and future development.

A. Basics of Historic Preservation

> A.2.c – What is historic?

Generally a building, structure, site, or object gains the potential to become a historic and/or archaeological resource upon its fiftieth birthday; however, this is only the initial requirement. There are other points that must be considered as well. Is it associated with historic events or persons (national or local)? Does it have distinctive physical characteristics? Could it provide important information about history or prehistory?

Every historic resource has a period of significance, or the time span during which it gained architectural, historical, or cultural significance. Buildings within a neighborhood often share common characteristics which provide a sense of place, including setbacks, scale, form, and orientation—which combine to establish a rhythm and development pattern.

> A.2.d – Community benefits

The benefits of historic preservation are numerous yet sometimes difficult to quantify. Three areas are most visible: community benefits, environmental benefits, and economic benefits. The livability of a community rests on protection of the built environment along with its unique architectural and decorative features, conservation of open space, maintenance of a sense of place, integration of appropriate new construction, and retention of pedestrian friendly streets and sidewalks.

This creates a quality of life that encourages connection and interaction among residents and visitors, contributes to a physical sense of neighborhood, reinforces desirable social patterns, and fosters a feeling of security. The Stone Mountain Historic District and Design Guidelines protect the city’s cultural resources by identifying them as valuable assets for the entire community, while providing a central point and a means of conveyance for sustainable change and development.

A. Basics of Historic Preservation

> A.2.e – Environmental benefits

The demolition of historic buildings causes a strain on the environment by creating the need for the production of new building materials. The repair and reuse of an existing building conserves and protects valuable natural resources by “recycling” rather than disposing of them. This results in a savings of energy as well as money, since it can often cost less to preserve original building elements rather than replace them.

There are instances where appropriate rehabilitation procedures may cost more than less sensitive treatments. In such situations, there are sometimes special economic incentives available to help offset potential added costs.

> A.2.f – Economic benefits

Historic preservation is a way of preserving a historic place, incubating small businesses, revitalizing downtowns, generating local jobs by using local materials and labor, and creating improvements in a community. Additionally, the availability of centrally located housing, which can often be accommodated through the rehabilitation of historic buildings, results in increased property values and tax revenues, creating a climate for investment and a pattern of healthy growth.

Heritage tourism is an economic development tool designed to attract visitors to an area based on the unique aspects of the locality’s history, landscape, and culture. Many people are willing to travel to see authentic reminders of our national, state, and local history; they are drawn to specific communities by their historic character. These visitors typically stay longer and spend more money during their visit than other tourists. Not only are local and regional pride given a boost, but the creation of jobs and a good source of revenue for the community are realized.

A. Basics of Historic Preservation

A.3 – Legal Basis

Passed into law in 1980, the Georgia Historic Preservation Act confirmed the preservation of the state’s historic resources as a matter of public interest and benefit. Additionally, the Act authorizes Georgia’s cities and counties to enact local ordinances, such as the Stone Mountain Historic Preservation Ordinance (See Appendix), that create historic preservation commissions and designate historic buildings and districts. These ordinances enable the regulation of alteration and demolition of designated properties, as well as new construction that may affect these properties at the local level.

In 1989, upon the passage of the Georgia Planning Act, Georgia became one of the first states to require the consideration of historic resources within local, regional, and state comprehensive plans. This, in tandem with the Georgia Historic Preservation Act, maintains a solid legal basis for the protection and regulation of historic resources within the state.

A.4 – Economic Incentives

> A.4.a – Certified Local Government

Stone Mountain is a **Certified Local Government** (CLG), a designation which offers municipalities the opportunity to participate more directly in state and federal historic preservation programs. Participation in the CLG program requires that a municipality have a historic preservation ordinance and a historic preservation commission. As a CLG, the community is eligible to apply for Historic Preservation Fund (HPF) grants for a variety of local preservation activities. The level of funding is contingent upon the annual appropriation from the National Park Service. Grant applications are available from the SHPO annually.

A. Basics of Historic Preservation

> A.4.b – Georgia Heritage Grants

Georgia Heritage grants are authorized for local governments and non-profit organizations for a range of preservation activities, including building rehabilitation and architectural documentation, development of plans and specs, and analysis/tests. Properties must be listed in the Georgia Register of Historic Places before funds can be released.

- 1) The limited funding level is targeted to building rehabilitation and pre-development costs such as plans, specs, analysis, and documentation.
- 2) Grant awards are only a small fraction of real need.
- 3) Local commitment is built in. Although a 40% cash match is required for all projects, most contribute much more since grants are “seed” grants or for stabilization.
- 4) Often, historic properties owned by local governments or non-profit groups have no other source of financial assistance, specifically for preservation.
- 5) There is a public value for use of these state funds since the Historic Preservation Division provides technical assistance, helps project feasibility by offering rehabilitation advice, monitors the projects, and ensures public access to the property.

> A.4.c – Tax Incentives

A.4.c.1 – Georgia State Income Tax Credit for Rehabilitated Historic Property

To be eligible for this program, a property must either be eligible for or listed in the Georgia Register of Historic Places. The Rehabilitation must meet the Georgia Department of Natural Resources Standards for Rehabilitation and be certified by the Georgia Department of Natural Resources. Both historic houses and income-producing buildings are eligible.

A substantial rehabilitation test must be met for the state tax credit. If a historic house is used as a main residence for its owner, the expense of the rehabilitation must exceed the following: the lesser of \$25,000 or 50% of the building’s adjusted basis. For a historic house used by its owner as a main residence in a “target area”, the amount must exceed \$5000. For any other certified historic structure, the rehabilitation expenses must exceed the greater of \$5000 or the adjusted basis of the structure. It is important to note that at least 5% of qualified rehabilitation expenditures must be for work completed on the exterior of a building.

A. Basics of Historic Preservation

There are three levels of tax incentives for this program:

- The owner of a historic property that completes a Department of Natural Resources approved rehabilitation may qualify to take 10% of rehabilitation expenditures as a state income tax credit, up to \$5000.
- Should the house be located in a “target area”, the owner may qualify to take 15% of rehabilitation expenditures as a tax credit, up to \$5000.
- Any other certified structure may qualify the owner to take 20% of rehabilitation expenditures, up to \$5000.

A.4.c.2 – State Preferential Property Tax

Assessment Program for Rehabilitated Historic Property

This incentive program supports rehabilitation by offering a property tax assessment freeze for 8 ½ years. The property’s assessment is based on the following: the rehabilitated structure, the property on which the structure is located, and no more than two acres surrounding the structure. Any property wishing to qualify for this incentive must be listed or eligible for listing in the Georgia Register of Historic Places, either individually or as a contributing structure in a historic district. This also applies to historic houses and income-producing properties.

To be eligible, the following conditions must be met:

- A substantial rehabilitation test must be met when it comes to the cost of the rehabilitation. For a residential, owner-occupied property, the rehabilitation must increase the fair market value of the building by at least 50%. For a mixed use property (both owner-occupied residential and partially income-producing), the rehabilitation must increase the fair market value of the structure by at

A. Basics of Historic Preservation

least 75%. For a solely income-producing property, the rehabilitation must increase the fair market value of the structure by at least 100%.

- The property owner must obtain both preliminary and final certification of the project from the Historic Preservation Division of the Georgia Department of Natural Resources.
- The rehabilitation must be done according to the Georgia Department of Natural Resources Standards for Rehabilitation. The rehabilitation must also be completed within two years.

A.4.d.3 – Federal Rehabilitation Investment Tax Credit

This program is open to income-producing properties only. The program allows the owner of a certified rehabilitation to take advantage of a federal income tax credit equal to 20% of qualified rehabilitation expenses.

To be eligible, the following conditions must be met:

- The building must be listed either individually or as a contributing structure within a district on the National Register of Historic Places.
- The project must meet a substantial rehabilitation test. The cost of the rehabilitation must be greater than \$5000 and also must be greater than the adjusted basis of the property. Projects must usually be finished within 2 years of approval by the National Park Service.
- A property must be used as an income-producing property for at least 5 years following the rehabilitation.
- The rehabilitation must be done in accordance with the Secretary of the Interior's Standards for Rehabilitation.

A. Basics of Historic Preservation

In order for the project to be approved, it must be reviewed by the Historic Preservation Division of the Georgia Department of Natural Resources and then certified by the National Park Service.

To apply for, or for more information on any of these programs or for information on federal tax incentives contact the Tax Incentives Coordinator at the Georgia Department of Natural Resources Historic Preservation Division, or visit the website at www.gashpo.org.

A. Basics of Historic Preservation

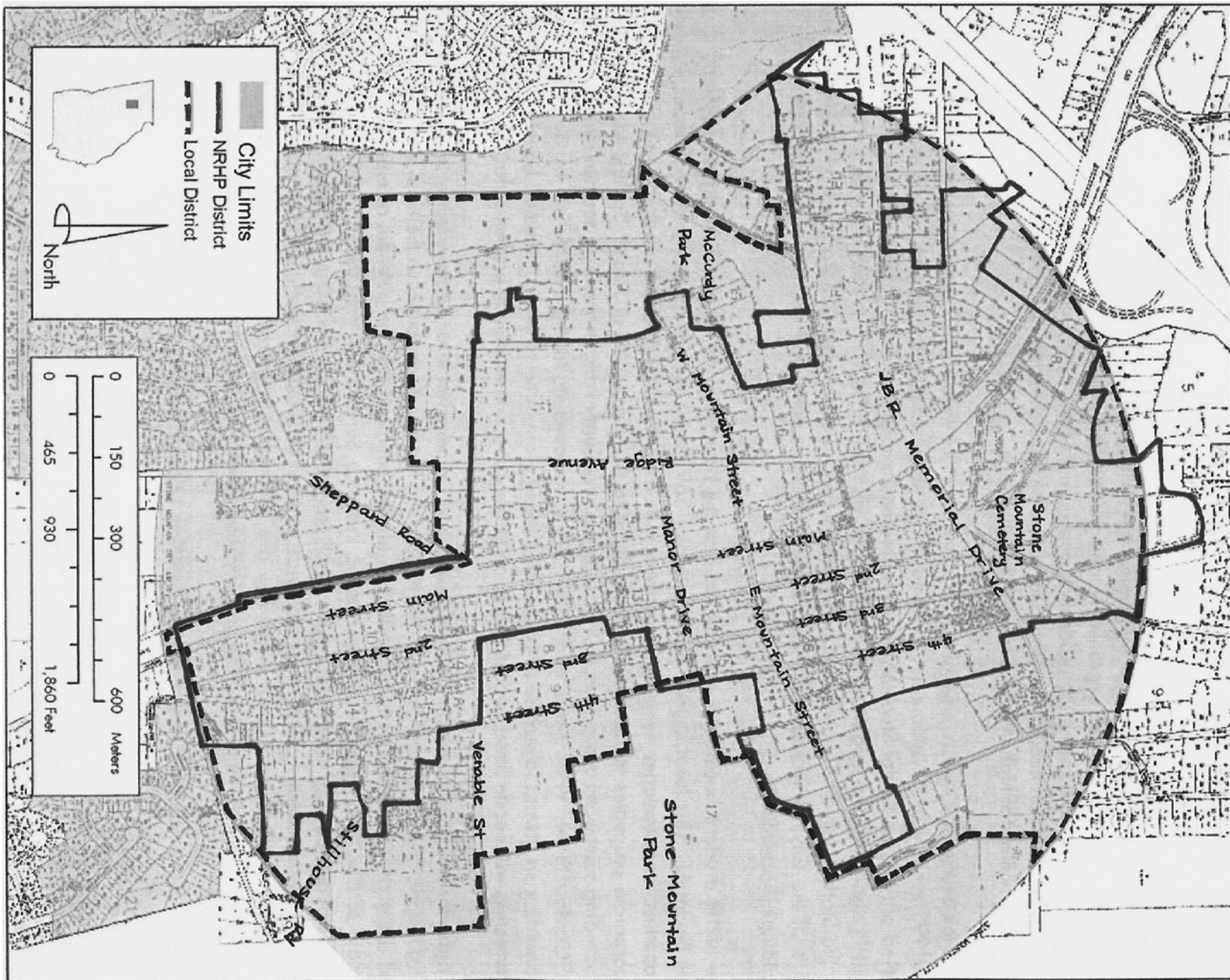

B. Historic Overview

B.1 – General History

The area presently known as the City of Stone Mountain was originally part of Creek Indian territory, but became part of Georgia in 1821 with the Creek Indian Cession. The lands received from the Creek Cession formed six counties, including DeKalb, which was organized in 1822. A land lottery followed soon after the Creek Cession, and by the late 1830s Andrew Johnson had purchased the majority of seven land lots in the 18th district of DeKalb County that would eventually become the City of Stone Mountain.

The settlement of New Gibraltar, established north of the mountain and east of the future City of Stone Mountain, was incorporated into a city in 1839. Four years later, in anticipation of the approaching Georgia Railroad line, settlement shifted towards Johnson's homestead as he sold off portions of his land to settlers. The articles of incorporation for New Gibraltar were amended, shifting the city limits

to include everything within a 600-yard radius of Johnson's house. By 1845, the Georgia Railroad made it to the city and two years later, in 1847, the city was officially incorporated with a new name: Stone Mountain.

Although Stone Mountain would eventually rely heavily on the granite quarrying industry to

By the late 1830s Andrew Johnson had purchased the majority of seven land lots in the 18th district of DeKalb County that would eventually become the City of Stone Mountain.

bring settlers, tourists, and business to the area, agriculture was the primary occupation and source of income for most residents in the early days of the settlement. The 1850 census lists 38 households within the city limits and 111 households in the area, 52 of which were listed as farmers. It would take several years for the quarrying industry to develop following the

first commercial collection of granite from the mountain between 1845 and 1850; at that time, fragments of the stone could be easily removed and carted off without the use of heavy machinery.

By 1860, of the 164 households within the city limits, agriculture remained the most prominent occupation with stonemasons coming

B. Historic Overview



Figure B1 - This photograph shows the Stone Mountain Inn, at the corner of Main Street and Manor Drive, when it still had its balcony. This would be a good resource for reconstructing the balcony on the current building.

in second. The 1860 census recorded 290 slaves in Stone Mountain, most of whom were involved in agriculture. Other occupations listed in the 1860 census suggest that a commercial center was developing around the railroad. Tourism was evolving into a major industry for the city because of the railroad, which brought people to see the natural attractions of the area. In fact, several hotels were constructed in the 1840s to accommodate visitors.

Another attraction was an agricultural fair established in the city in 1846 by the Southern

Central Agricultural Society under the direction of John W. Graves. Three years later the fair had outgrown the city and had to be moved. The Civil War brought development to a standstill.

Union General William Tecumseh Sherman destroyed the commercial center of the City of Stone Mountain on his “March to the Sea” in 1864, burning buildings and demolishing the rail line, but Stone Mountain began rebuilding not long after the end of the Civil War. The African American neighborhood of Shermantown was established in the late 1860s, after Reverend F. M. Simmons of the City of Stone Mountain’s Bethsaida Baptist Church and several other African American church members from the area met with General Sherman in Washington, D.C., to discuss the future of newly freed slaves. The neighborhood was separated from the rest of the city by two vacant blocks but the residents continued to play a vital role in the City of Stone Mountain’s development.

In 1869 the Stone Mountain Railway and Granite Company was established, with white and black residents of the City of Stone Mountain working in the quarry. Additionally, a spur line was set-up to transport people and granite from the

B. Historic Overview

mountain to the city. William and Samuel Venable purchased the mountain and started a quarry in 1887, signaling what would be the City of Stone Mountain's biggest growth since the establishment of the railroad. Less than ten years later, the City of Stone Mountain was the second largest city in DeKalb County with 1,500 inhabitants. The city had become a commercial center for the area, producing approximately 2,000 feet of granite curbing and 200,000 paving stones a day by the turn of the 20th century.

The City of Stone Mountain continued to grow in the early 20th century with many new activities and organizations finding a home in the city. The city itself followed the growth pattern of a railroad-strip town, with commercial development occurring opposite the train depot and the streets being laid out in a grid-iron pattern and the railroad line serving as the central spine.

Shermantown had a similar grid-iron street configuration, although a few streets, such as Stillhouse Road, developed on a curvilinear pattern and the streets throughout the neighborhood were not uniform in width. The neighborhoods that formed around the commercial center were laid

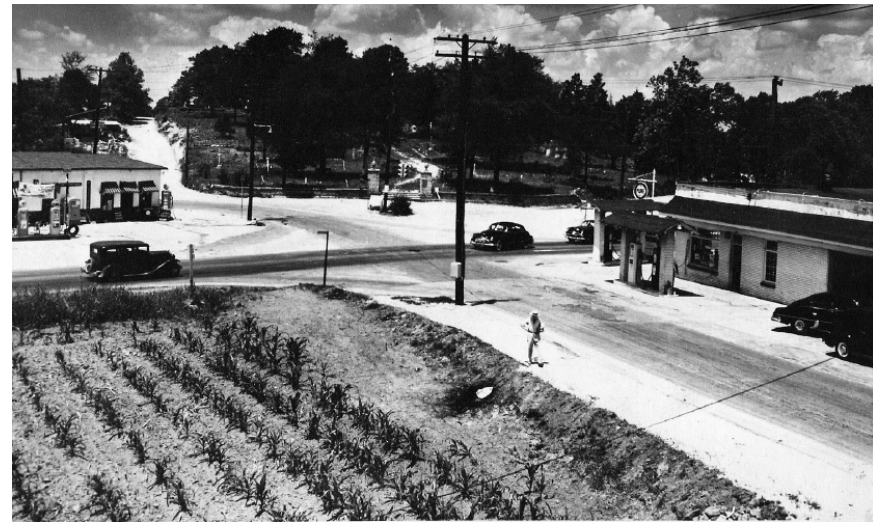

Figure B2 - This photograph shows the intersection of what is now Main Street and James B. Rivers Memorial Drive. The Stone Mountain Cemetery is in the background

out with more curvilinear streets, and the houses were set on larger lots than those in Shermantown. Granite remained an integral part of Stone Mountain's existence, not only by providing jobs and income for the city, but also by its use in the construction of the hundreds of houses built during the early 20th century.

The Venables sold their quarry in 1911; it was renamed the Stone Mountain Granite Company. The quarry continued to operate until 1935. A large number of homes were built between 1905 and 1930 to house the people that continued to move to the City of Stone Mountain, largely as

B. Historic Overview



Figure B3 – This photograph from the mid 20th century shows commercial buildings on Main Street.

a result of the granite industry. Shermantown was fully developed by the 1920s, with several community buildings, businesses and a sizable population; the neighborhood had a school, churches and lodge buildings to support the African American community. A fire devastated a portion of the City of Stone Mountain's commercial block in 1918, prompting a law requiring all commercial buildings to be constructed of masonry and, in 1924, the establishment of a fire station. The fire did not stop the commercial center's growth—by the 1920s, Stone Mountain had a host

of filling stations, repair shops and car dealerships to support the new automobile industry.

During the early 20th century, the City of Stone Mountain was also home to a revival of the Ku Klux Klan, led by James Venable, nephew of quarry-owner Samuel Venable, and Colonel William Simmons. Venable and Simmons organized rallies and cross burnings atop the mountain that continued until the late 1950s; the cross burnings atop Stone Mountain were the foundation for the resurgence of the modern Klan. James Venable would become the Imperial Wizard of the Ku Klux Klan in the late 1960s and Klan activities continued in the City of Stone Mountain until the 1970s.

The Great Depression caused another downturn in Stone Mountain's economy. The 1930s saw the closing of several of the city's quarries as well as the failure of the Bank of Stone Mountain. The Works Progress Administration attempted to alleviate some of these problems by providing jobs for unemployed quarry workers. A mattress factory was established at the site of the old Stone Mountain Inn on Main Street and quarry workers were used to construct the Rock Gym on Ridge Avenue.

B. Historic Overview

The mountain also continued to bring tourists to the area. The granite industry reached its peak in the 1950s and businesses slowly began to shift to the periphery of the city, resulting in a greater reliance on tourism to bring people to the City of Stone Mountain. A meeting between the Stone Mountain Woman’s Club and community leaders in 1961 resulted in a plan to improve Stone Mountain socially and physically. In 1964, as a result of the Women’s Club’s work, Robert and Company, an Atlanta architectural, planning, and engineering firm, compiled a comprehensive report of the city that helped initiate a downtown revitalization. Several other civic improvements occurred in the city during the 1960s, including the rehabilitation of the old train depot into City Hall, the construction of a new jail, the establishment of a youth corps, improvements to Shermantown’s roads, and the opening of a DeKalb County library branch in the city. Further revitalization for the city was stimulated in the following years by the opening of the Stone Mountain Memorial Park in 1970, along with transportation improvements such as MARTA.

Today, the City of Stone Mountain continues to build on the work of the Stone Mountain Women’s Club with revitalization and improvement efforts. As a designated Georgia Main Street city, Stone Mountain promotes the preservation of its historic resources while supporting smart growth. The City of Stone Mountain continues to work to improve its infrastructure and make the city a good place to live, work and play; residents are encouraged to keep the historic character of the city in mind whenever new projects are undertaken, ensuring that the City of Stone Mountain will continue to serve as a resource for understanding Georgia’s past and improving its future.

(This General history of the City of Stone Mountain compiled from the National Register of Historic Places nomination form for the Stone Mountain Historic District prepared by the Georgia State Historic Preservation Office.)

B. Historic Overview

B.2 – The Historic District

The City of Stone Mountain was listed on the National Register of Historic Places on December 7, 2000. Prior to its nomination to the National Register, Stone Mountain designated a Local Historic District. The Stone Mountain Historic Preservation Commission was created in 1996, with its first goal being the creation of the Stone Mountain Local Historic District. The HPC works to maintain the character of the historic buildings within the Local Historic District by reviewing all projects that will affect the integrity of the district.

In 2007, New South Associates completed a re-survey of the City of Stone Mountain’s historic resources. This was an update to a historic resources survey completed in 1993. The original survey included 255 properties within the city limits of Stone Mountain that were 50 years or older. The 2007 survey identified an additional 132 properties that had reached 50 years in age since the previous survey; the update also included a review of the previously identified properties to ensure that they were still extant and had not been altered to such a

degree as to make them no longer contributing to the historic district.

The City of Stone Mountain’s historic properties are what give the National Register and Local Historic Districts their architectural integrity and character, and it is important to maintain them. Owners have a responsibility to their community to maintain the character of the buildings and sites.

It is for this reason that the Certificate of Appropriateness process is important (see Section C). Any modification to a historic building or construction of a new building within the Local Historic District must be approved by the HPC.

This ensures that growth will occur in a manner that will not destroy or compromise the historic character of the Local Historic District and that the historic character of Stone Mountain will be maintained.

In 2007, the population of the City of Stone Mountain was about 7,000. Although Stone Mountain Park still brings people to the area, the city experienced a downturn in economic and tourist activity in the late 20th and early 21st centuries. Development elsewhere began to divert

B. Historic Overview

businesses and residents to other areas of Atlanta and the surrounding suburbs. The establishment of a Tax Allocation District (TAD) was under way in 2007, with the hopes that new development would bring people back to the city and help improve the area.

A streetscape project, to be completed in several phases, was also initiated in 2007. The City of Stone Mountain is constantly working towards improvements that ensure this historic city is preserved for future generations.

C. Stone Mountain HPC/COA Review Process

C.1 – Historic Preservation Commission

In the interest of promoting and protecting the historic and aesthetic qualities of Stone Mountain, the mayor and city council passed the Historic Preservation Ordinance. This legislation has created the City of Stone Mountain Historic Preservation Commission (HPC), which is tasked with establishing “a uniform procedure for use in providing for the protection, enhancement, perpetuation and use of places, districts, sites, buildings, structures, objects, landscape features and works of art having special historical, cultural, or aesthetic interest or value” within the Stone Mountain Historic District. It is the job of the HPC to review proposed alterations, new construction, and the demolition of designated properties. This design review process ensures that changes within the Stone Mountain Historic District will not disrupt the district’s historic integrity and character.

> C.1.a – Membership

According to the Historic Preservation Ordinance, the HPC consists of no less than five and no more than seven members who have been residents of the city for at least one year prior to their appointment by the mayor of Stone Mountain. A majority of members must be licensed architects, landscape architects, interior designers or professionals in the fields of history, architectural history, planning, archaeology or related disciplines.

C. Stone Mountain HPC/COA Review Process

> C.1.b – Roles and Responsibilities

The Historic Preservation Ordinance establishes twelve powers and duties of the HPC.

- The HPC is responsible for an inventory of all properties within the historic district that are listed on or eligible for the National Register of Historic Places or the Georgia Register of Historic Places.
- The HPC recommends to the Mayor and City Council specific places, districts, sites, buildings, structures, objects, or works of art to be designated by ordinance as historic properties of the historic district.
- The HPC reviews applications for certificates of appropriateness (COA) to alter or demolish historic structures or for new construction, and it has the power to grant or deny the applications.
- The HPC can recommend to the Mayor and City Council that historic designation of any place, district, site, building, structure, object or work of art may be amended, revoked, or removed.
- The HPC can restore or preserve any historic properties acquired by the city, with the approval of the Mayor and City Council.
- The HPC may recommend that the city acquire façade and conservation easements.
- The HPC can conduct educational programs on historic properties located within the city and on general historic preservation topics.
- The HPC can make investigations and studies of matters relating to historic preservation, including consultation with historic preservation experts or other persons.
- The HPC can seek local, state, federal and private funds for historic preservation and make recommendations for the use of these funds.
- The HPC may submit to the Historic Preservation Division of the Georgia Department of Natural Resources a list of designated historic properties and historic districts.
- The HPC may participate in private, state and federal historic preservation programs.
- The HPC can review and make comments to the state office concerning the nomination of properties within its jurisdiction to the National and Georgia Registers of Historic Places.

C. Stone Mountain HPC/COA Review Process

C.2 – Certificate of Appropriateness

What is a **Certificate of Appropriateness** and in what situations might one be needed?

> C.2.a – Determining If You Need a COA

Any property owner or occupant planning new construction or an alteration or material change to any building, structure, or site located within the City of Stone Mountain Designated Historic District must apply for and obtain an approved Certificate of Appropriateness (COA) before construction or remodeling can begin. A COA may be approved, approved with conditions, or denied by the Stone Mountain Historic Preservation Commission.

To determine if a building, structure or site is located within the locally designated historic district, refer to the map on Page 12 or call the City of Stone Mountain at (770) 498-8984. A planned demolition or relocation of a building within the locally designated historic district also requires an approved COA.

A Certificate of Appropriateness is required for any of the following:

- Any new construction of buildings including secondary buildings such as garages, sheds, and outbuildings
- Any additions to existing buildings
- Any rehabilitation, alteration, or removal of existing building façades or exterior building materials including siding, roofing, or foundations
- Any rehabilitation, alteration, or removal of an existing building’s windows, doors, porches, or roofs
- Any demolition of a building
- Any relocation of a building
- Any tree removals
- Any site additions such as pools
- Any exterior modifications to mechanical systems
- Any additions or modifications to fences, entrance walks, outdoor lighting, retaining walls, driveways, and landscape architectural elements such as gazebos and fountains
- Any addition or modifications to commercial signs that can be viewed from the public right-of-way
- Any excavations on a property for construction purposes

C. Stone Mountain HPC/COA Review Process

A Certificate of Appropriateness is not required for any of the following:

- An alteration that does not change the design, material, or exterior appearance of the building
- Modifying property use
- General Maintenance
- Changes in exterior paint colors

> C.2.b – Using the Design Guidelines

The Stone Mountain Historic District Design Guidelines will be referenced by the HPC during their review of submitted COAs. This manual is meant as a guide for the HPC to render decisions and offer recommendations to the applicant that will preserve the historic character of the District.

Stone Mountain Historic District property owners should consult the guidelines before planning changes to their property that will require a COA. Guidelines have been created for both residential and commercial properties. The guidelines have also been organized into subsections to address specific aspects of a building or property. Each subsection provides recommendations designed to preserve the historic character of the property in the most appropriate manner. Although a specific subsection can address a planned project, property owners should review the entire guidelines for a full understanding of their resources. The guidelines also detail the design review process. Property owners any questions about the guidelines with the HPC before undertaking a project that will alter their property.

C. Stone Mountain HPC/COA Review Process

C.3 – Design Review Process

The City of Stone Mountain’s Historic Preservation Ordinance requires property owners obtain a COA (a copy of the form follows Page 208) before performing any work that would materially alter the appearance of a designated historic property-, building, structure or site within a historic district, including new construction.

The COA application may be obtained from the HPC office or downloaded from the City of Stone Mountain website at www.cityofstonemountain.org under the Historic Preservation tab.

The Stone Mountain HPC encourages potential applicants to meet with the HPC prior to submitting an application. The HPC will review the conceptual project and help the property owner understand what is appropriate within the Stone Mountain Historic District or with a specific historic property. Consulting with the HPC before contracting for professional design services could save the property owner valuable time and money.

Submission of the COA application, with all supporting documentation (eight copies of each), shall be made at the following address:

Stone Mountain City Hall

922 Main Street

Stone Mountain, GA 30083

All material should measure 8 ½” x 11,” though larger format could be provided if it’s necessary to give a clearer representation of the applicant’s request.

Incomplete applications will not be reviewed by the HPC.

Applications submitted by noon 14 days or more before a regularly scheduled HPC meeting will be placed on that month’s agenda. Should that submission deadline fall on a weekend or holiday, the application would be considered if submitted by the next business day. The HPC meets on the third Tuesday of each month, at 7:30 p.m., unless otherwise posted outside City Hall.

City Hall will notify applicants when they have been placed on the agenda for an upcoming meeting.

C. Stone Mountain HPC/COA Review Process

Should the HPC determine that the application for avCOA merits a public hearing, the HPC will post notice, in the form of a sign, displayed in a conspicuous place on the property under consideration.

Attendance by the applicant or an authorized representative at the HPC meeting where an applicant's request is to be reviewed is mandatory and is to the advantage of the applicant. If neither is present to address questions which might arise or to respond to clarification issues, the HPC could deny the application.

Approval or rejection of the COA application will be completed within 45 days of the submission of a complete application. The HPC may approve the application as proposed, approve with modifications or reject the application.

City Hall will notify the applicant of the HPC decision. If the COA is approved, the applicant must then obtain the appropriate building permits.

Any person adversely affected by any COA decision made by the HPC may appeal the decision to the City Council. Appeals must be filed within fifteen (15) days after the HPC's decision or, in the case of failure of the HPC to act, within

fifteen (15) days of the expiration of the 45 day period allowed for the HPC action. Appeals from decisions of the City Council may be made to the Superior Court of DeKalb County.

C. Stone Mountain HPC/COA Review Process

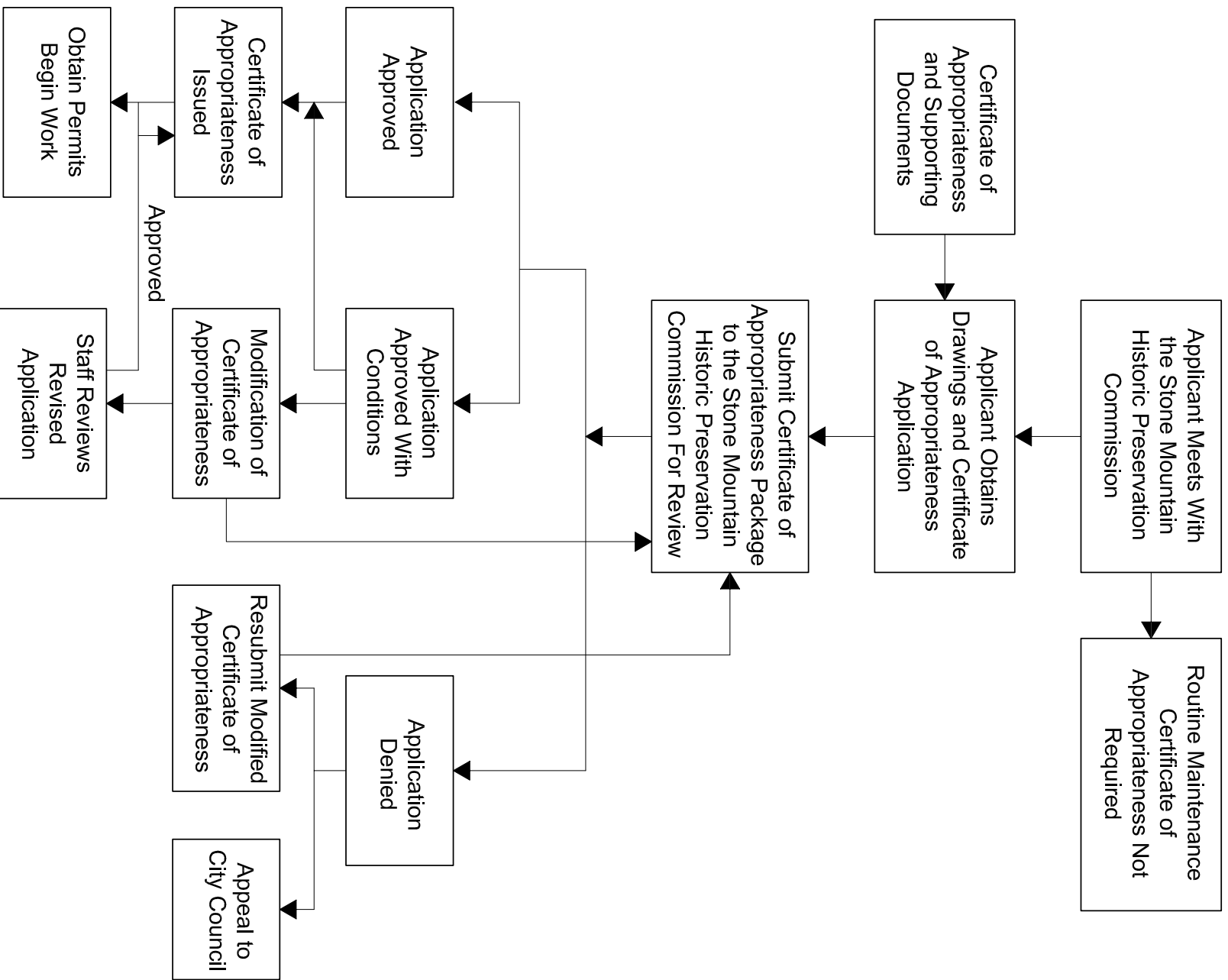

D. Historic District Character

The Stone Mountain Historic District has varied historic characters that distinguish it not only as an important historic place, but also as a diverse collection of historic buildings. There are three definable character groups in the district: the commercial Main Street, the residential area anchored by East and West Mountain streets, and Shermantown. Each of these three areas has a distinct character and its own common building types and styles. When determining what changes are historically appropriate in the district, it is necessary to examine each building within the context of its specific neighborhood.

To understand the character-defining elements of the historic buildings in these neighborhoods, one must take into consideration two distinct categories: building type and building style. Each of these aspects may indicate the historical period in which the building was most likely built.

The type of a building is its unadorned form and interior layout. This is the overall form, outline, or envelope of the main or original part of the building, as well as the general layout of interior rooms. A type is defined by the formula:

plan + height = type. Two houses with the same floor plan and the same height will belong to the same type.

A building's type does not refer to the materials used in construction, as the same type of house with identical plans can be constructed from a number of different materials (i.e.: a "log cabin" is not a house type). In some cases, other architectural traits become part of the definition. Roof form, the location of doors or chimneys, or the kind of porch may determine type or subtype. In determining a building's type, only the core, or main part, of the building is considered, excluding side wings, rear service ells, later additions and attached outbuildings.

The style of a building is its external ornament or decoration. A building's style has two main aspects: form and ornamentation. The overall stylistic form of a building is found in its proportion, scale, massing, symmetry or asymmetry, and the relationship among parts such as solids and voids or height, depth, and width. The decoration of a style is in the decorative or ornamental elements that have been put on a building in a systematic pattern or arrangement. When all

D. Historic District Character

elements that define a style come together, a building can be high style. When only a few stylistic elements are found, a house is called a vernacular interpretation of a style, or one with elements of a style. A vernacular building is one built from locally available materials following traditional building practice and patterns without having been designed by an architect.

In addition to the types and styles of buildings, the character of the Stone Mountain Historic District itself must also be taken into consideration. This district has three distinct character areas: the commercial Main Street, the residential East and West Mountain Street, and Shermantown. The types, styles, and defining characteristics found in each of these areas are considerably different from one another, demanding their consideration as separate parts of the district whole.

D.1 – Overview of Character

> D.1.a – Commercial (Main Street)

The Stone Mountain Historic District’s commercial center, found mainly on Main Street, consists of traditionally commercial buildings, residential buildings adapted for commercial use, and a few high style residential buildings that retain their residential function. The converted buildings were originally Saddlebag, Central Hall, Gabled Ell, and Bungalow Cottages, and ranch houses have also been converted. Styles include both high style and elements of Craftsman and Folk Victorian.

Commercial buildings in the district are the most significant and defining feature of the commercial area. Types include One-part Commercial Block, Two-Part Commercial Block, and Arcaded Commercial Block.

D. Historic District Character

> D.1.b – The Residential Area Anchored by East and West Mountain Streets

Examples of high-style residential buildings, as well as some residential-turned-commercial buildings, landmark churches, and open spaces characterize East and West Mountain streets and their neighboring streets.

The house types found on East and West Mountain Streets are numerous, including both one- and two-story houses. House types found in this area include the central hallway, extended hall-parlor, Georgian, gabled ell, Queen Anne, new south, pyramid, and temple front cottages, as well as shotguns and bungalows. Two-story house types include Georgian houses and ranch houses, as well as a small number of American small houses.

Residential house styles included in this area are Georgian, Greek Revival, Queen Anne, Craftsman, English Vernacular Revival, and Folk Victorian. Some houses have only elements of a style or are simply vernacular.

> D.1.c – Shermantown

Shermantown contains vernacular house types and some commercial buildings. The buildings found in this area of the district are generally of a smaller scale than on Main Street or in the residential area anchored by East and West Mountain Street. Shermantown is also characterized by landmark churches, as well as corner stores of a scale comparable to the residential buildings surrounding them.

House types found in Shermantown are, by and large, one-story buildings, including gabled ell, hall-parlor, central hallway, temple front, and pyramid cottages, as well as shotguns, American small houses, and extended American small houses. Buildings in this area generally have no formal style.

D. Historic District Character

> D.1.d – Viewshed Protection

Stone Mountain itself has played an important role in the city’s development from its founding. Besides serving as a namesake, the mountain has acted as the city’s largest economic draw, both for industry and tourism. In addition to its local importance, the mountain is a geologically-significant granite monadnock, claimed by some to be the largest exposed mass of granite in the world.

Much of the Stone Mountain Historic District benefits from a direct view of the mountain, and the mountain’s constant visual presence is a significant part of the historic character of the District. Because of the mountain’s role in the city’s history and livelihood, any project concerning a property in the Stone Mountain Historic District should be undertaken in a manner that does not obstruct its view or visual impact.

D. Historic District Character – Types

D.2 – Types and Styles

> D.2.a – House Types

Hall-Parlor

The hall-parlor plan consists of two unequal rooms. Entry is into the larger of the two—the hall—which historically served multiple functions. One or two exterior end chimneys heat the rooms in this plan. Most remaining Georgia examples were built in the last half of the 19th century and the first three decades of the 20th century. Examples of the hall-parlor can be found in Shermantown.



Figure D1 - This is an example of a hall-parlor type house found on Stillhouse Road. The door is at the center of the front façade, but the house has the small size of a Hall-Parlor type house.

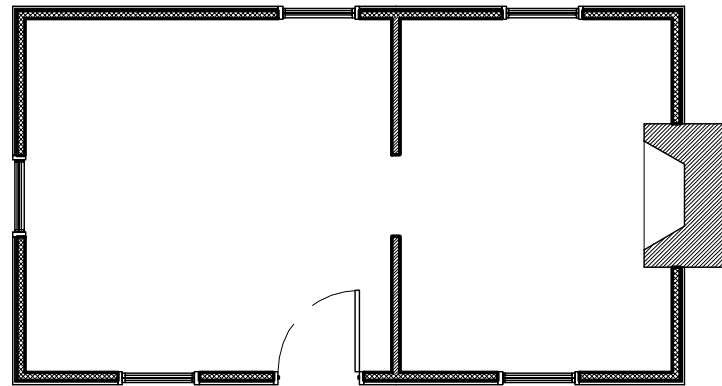

Figure D2 - The floor plan for the hall-parlor house shows two, small and unequal rooms with a chimney on one end.

D. Historic District Character – Types



Figure D3 - This is an example of a saddlebag found on Main Street.

Saddlebag

The saddlebag house is one of the most distinct house types. It is characterized by a single central chimney flanked by one room on either side. The rooms, which are usually square, may be joined by a vestibule which serves as a central entry, although it is not uncommon for each side to have its own exterior door. Gabled roofs commonly top such buildings. The majority of surviving saddlebag houses are found in mill villages constructed between 1910 and 1930, though examples survive from as early as the 1830s. Saddlebags are found clustered around the district's commercial Main Street.

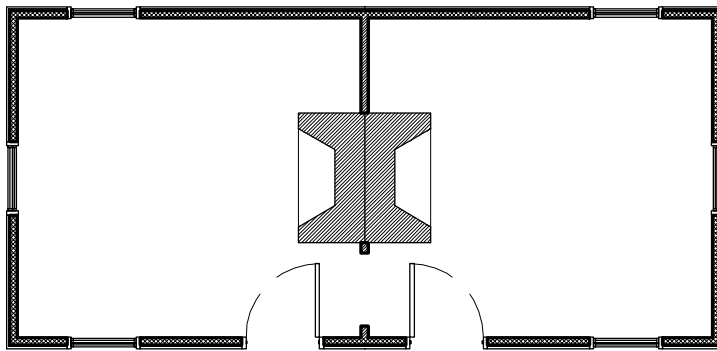

Figure D4 - This is a saddlebag plan view. Note the central chimney and the two doorways at the front of the building.

D. Historic District Character – Types

Central Hallway

This house type was extremely common in Georgia throughout the 19th century. Characterized by a central hallway or passageway between two rooms, it is only one room deep and typically has a gabled roof and exterior end chimneys. Most examples were built between 1830 and 1930, with clusters occurring in the periods 1840-60 and 1870-90. This building type can be found in the commercial, East and West Mountain Street, and Shermantown areas.



Figure D5 – This central hallway house is located on East Mountain Street. The two end chimneys and the central doorway are characteristic of the house type.

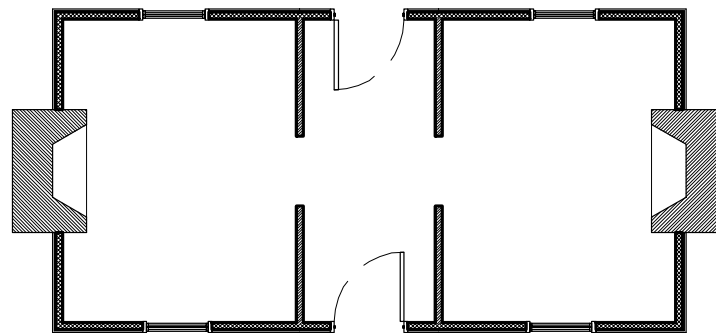

Figure D6 – This is the floor view for a typical central hallway type.

D. Historic District Character – Types



Figure D7 - This is an example of a Georgian cottage found on East Mountain Street.

Georgian Cottage

Named for its English Georgian floor plan and not the state of Georgia, the Georgian cottage consists of a central hallway with two rooms on either side. It is important to note that unlike the central hallway, it is two rooms deep. The roof is usually hipped but sometimes gabled. Chimneys are usually found in the interior of the house, between each pair of rooms, although they can also be found on the exterior ends. Georgian cottages are common in Georgia up to and throughout the 20th century, with the greatest concentration between 1850 and 1890. This house type is particularly prevalent in the residential area anchored by East and West Mountain streets.

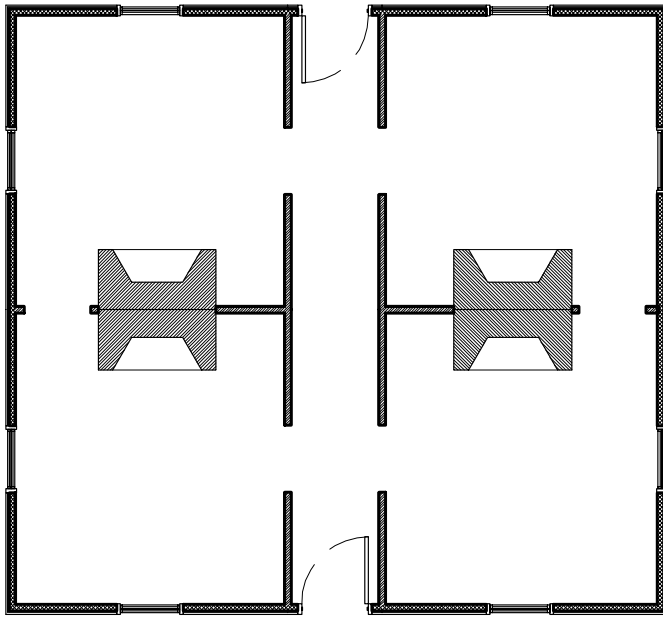

Figure D8 - The floor plan for the Georgian Cottage has four rooms, with two on either side of a central hallway.

D. Historic District Character – Types

Shotgun

The shotgun house has a long and narrow plan suited to narrow urban lots, one room wide and two or more rooms deep, usually three. There is no hallway, and all doors typically line up front to back. Although hipped roofs were used, shotgun roofs are usually gabled. These houses were usually built for low-income workers between the 1870s and 1920s. Shotgun plans can be found on East and West Mountain Street and also in Shermantown.



Figure D9 - This shotgun house is located on 3rd Street in Shermantown.

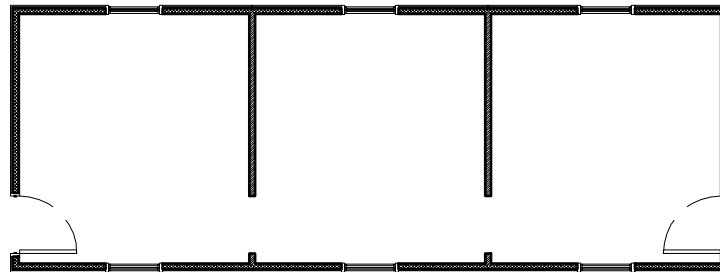

Figure D10 -The floor plan shows that all doorways are placed to one side of the house.

D. Historic District Character – Types



Figure D11 – This is an example of a gabled-ell cottage found on East Mountain Street.

Gabled Ell Cottage

In plan, the gabled ell cottage is T- or L-shaped and usually (but not always) bears a gabled roof. This cottage consists of a gable front at one end of a recessed wing that is parallel to the façade. The front door, which is located in the recessed wing, may lead into a hallway or directly into the room in the wing. This plan was most popular between 1875 and 1915. Examples of the gabled ell cottage can be found throughout the Stone Mountain Historic District.

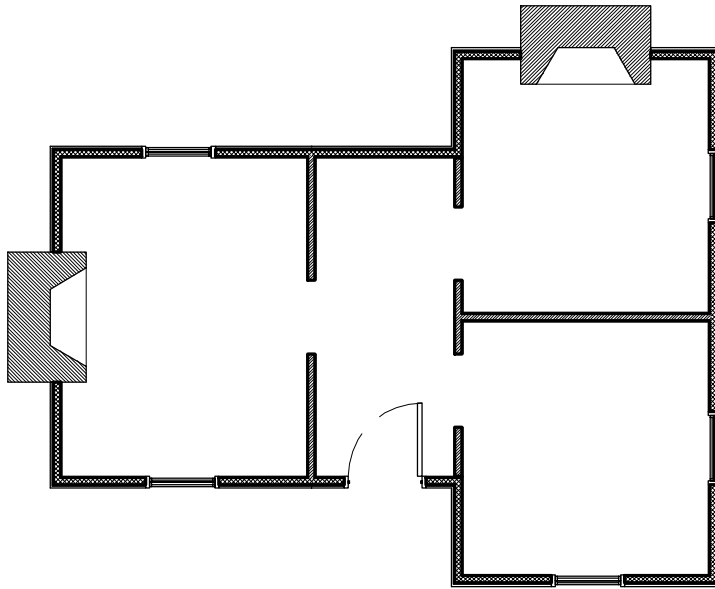

Figure D12 – This plan view for the gable ell type shows the characteristic “T” shape of the building, which is also known as a gable wing.

D. Historic District Character – Types

Queen Anne Cottage

While associated with the Queen Anne style of architecture, the Queen Anne cottage does not necessarily have to be in that style. This cottage is characterized by a square central mass with gabled projections to the front and side. Roofs over the central square may be either pyramidal or hipped, and chimneys are usually located on interior walls. Popular among the middle class during the 1880s and 1890s, Queen Anne cottages are found in rural and urban areas. They are distinguished from the closely related New South cottage by their asymmetrical room arrangement and lack of a central hallway. In the Stone Mountain Historic District, Queen Anne cottages are found in the residential area anchored by East and West Mountain Street.



Figure D13 – This Queen Anne cottage is located on Sheppard Road and was built to face the railroad tracks.

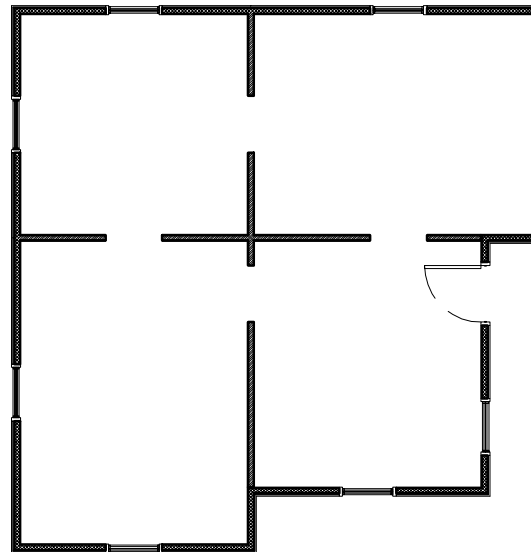

Figure D14 – Notice the asymmetrical floor plan of the Queen Anne type and the room that protrudes from the front of the building.

D. Historic District Character – Types



Figure D15 – This is an example of a New South cottage on Main Street.

New South Cottage

Popular in the Piedmont regions of Georgia among middle- and upper-middle class families between the 1890s and 1920s, the New South cottage is characterized by a square central mass with gabled projections. Unlike the Queen Anne cottage, the New South cottage has a generally symmetrical room arrangement and central hallway. The central hallway is typically flanked by pairs of rooms, one or both of which may project forward. Paired gables, which may project or remain flush to the central mass, are frequently used to enhance the symmetry of the design. Roofs of the central mass are usually hipped.

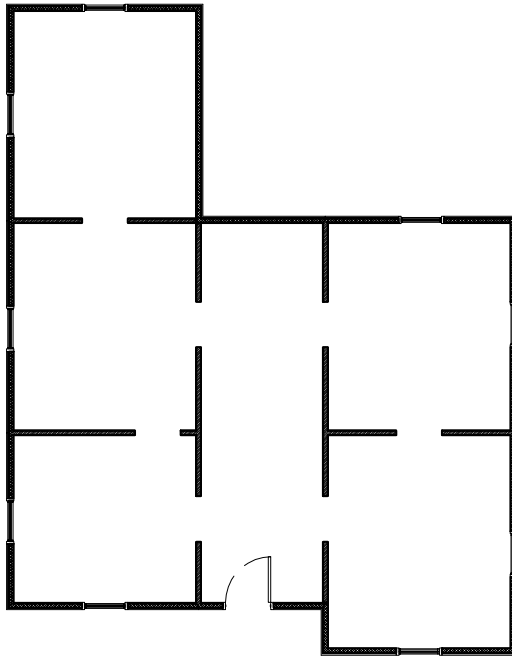

Figure D16 –The New South cottage has a room that protrudes from the front, much like the gabled ell cottage and the Queen Anne cottage.

D. Historic District Character – Types

Pyramid Cottage

Pyramid Cottages are among the simplest designs of historic housing in Georgia. They are generally characterized by a square mass with four principal rooms with no hallway. The roof is steeply pitched and pyramidal in shape, thus the name pyramid cottage. Largely popular in the region between the fall line and the coast, though examples are found state-wide in rural areas, the majority of pyramid cottages were built between 1910 and 1930. Pyramid cottages are found in both the residential area anchored by East and West Mountain Street and in Shermantown.



Figure D17 – This pyramid cottage is on 3rd Street in Shermantown.

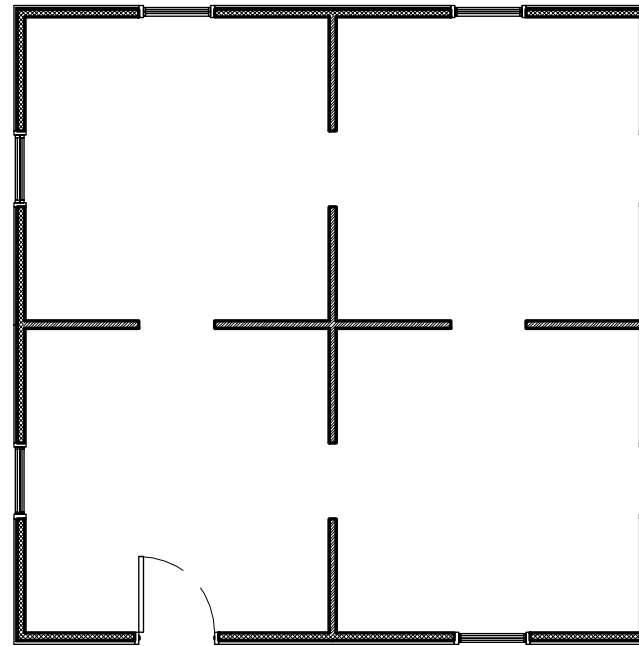

Figure D18 – The typical pyramid cottage plan view shows four rooms of equal size.

D. Historic District Character – Types



Figure D19 – This temple-front cottage is located on Beaver Run Road in Shermantown.

Temple-Front Cottage

The temple-front cottage has a long, rectangular plan with a full-width front porch beneath a gabled or hipped roof. It is usually three or more rooms deep, with a central hallway or hall-parlor plan. It was popular in the 1920s and 1930s, and examples may be found in the East and West Mountain Street areas as well as Shermantown.

D. Historic District Character – Types

Extended Hall-Parlor

Though similar to the temple-front cottage in its long, rectangular shape, the extended hall-parlor does not have a recessed front porch. It is three or more rooms deep with a hipped or gabled roof. This house type may closely resemble bungalow subtypes. Existing examples of the extended hall-parlor date from the 1920s and 1930s. This house type can be found in the residential area anchored by East and West Mountain streets.



Figure D20 – This is an extended hall-parlor on Cloud Street. Below is a graphic depicting a typical roof line and shape for the type.

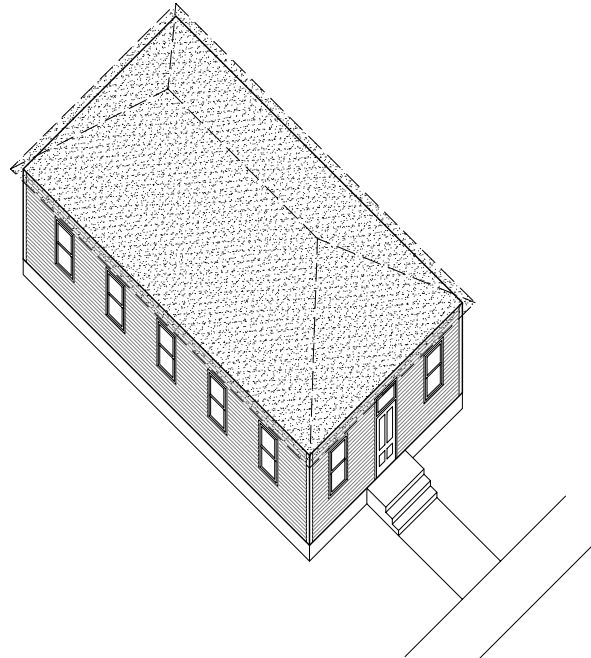

Figure D21

D. Historic District Character – Types



Figure D22 - This is an example of a front gable bungalow at the corner of Memorial Drive and 2nd Street.

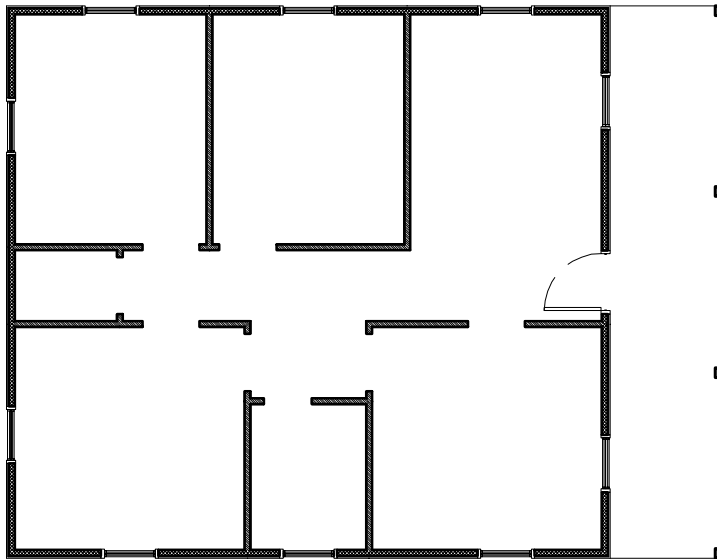

Figure D23 - The floor plan for the bungalow includes a front porch, one of its distinguishing features.

Bungalow

The bungalow type, sometimes mistakenly referred to as a style, is long and low with irregular floor plans within an overall rectangular shape. Two common aspects of the plan are integral porches and low-pitched roofs with wide overhangs. There are four bungalow subtypes based on roof forms and roof orientation: front gable, side gable, hipped, and cross gable. They were very popular between 1900 and 1930. Bungalows can be found in the commercial areas as well as East and West Mountain Streets.

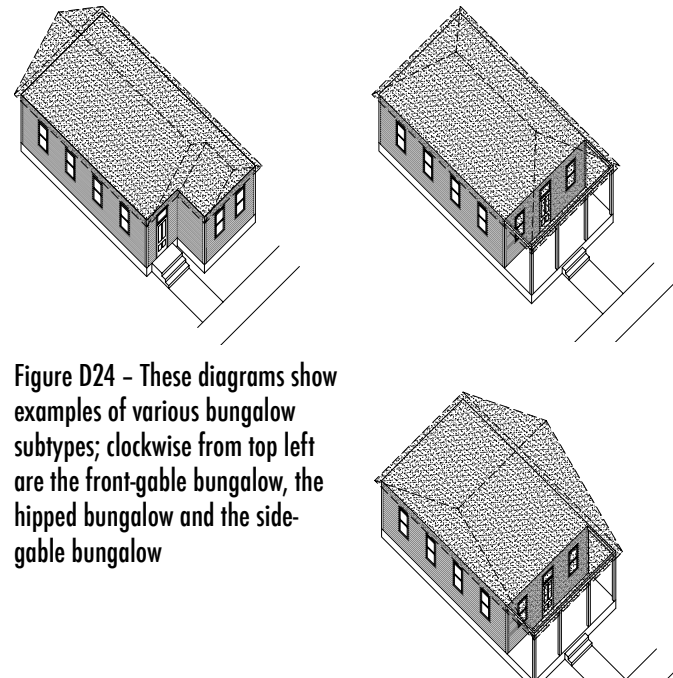

Figure D24 - These diagrams show examples of various bungalow subtypes; clockwise from top left are the front-gable bungalow, the hipped bungalow and the side-gable bungalow

D. Historic District Character – Types

Georgian House

Except for its two-story height, the Georgian house shares its characteristics with the Georgian cottage. It is two rooms deep, consisting of a central hallway with two rooms on either side, making a square or nearly square plan. The roof may be hipped or gabled. The Georgian house was popular from the first decades of the 19th century well into the 20th. Most extant examples date from its periods of greatest popularity, 1850-1860 and 1900-1930. Georgian houses may be found in the residential area anchored by East and West Mountain Street.



Figure D25 - This is the one example of a Georgian house in Stone Mountain, located on Ridge Avenue.

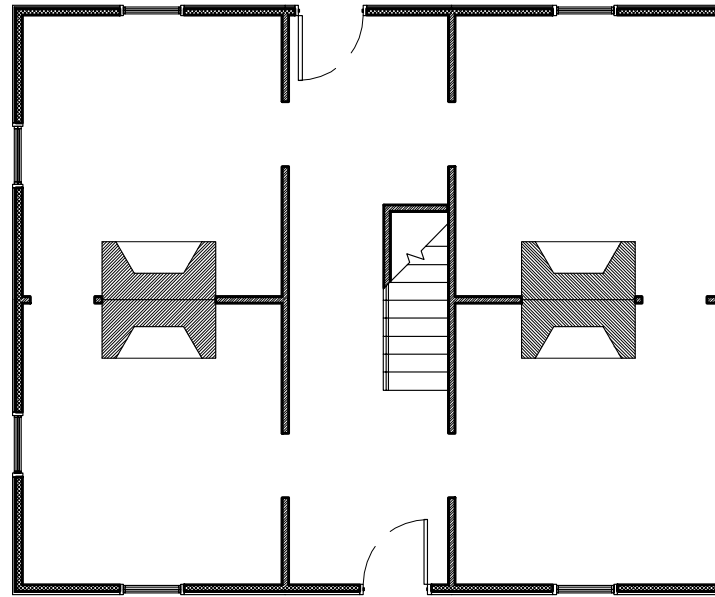

Figure D26 - The floor plan for the Georgian house is like that of the Georgian cottage, except with two stories instead of one.

D. Historic District Character – Types



Figure D27 –This American small house is on Ridge Avenue.

American Small House

The American small house gained prevalence during the economically challenging Great Depression and World War II years. It is a compact single-family house built between the mid 1930s and the early 1950s. It contains from three to six major rooms. Particularly elongated and horizontal variants of this plan are referred to as the extended American small house. This house type is found in the residential area anchored by East and West Mountain Street and Shermantown.

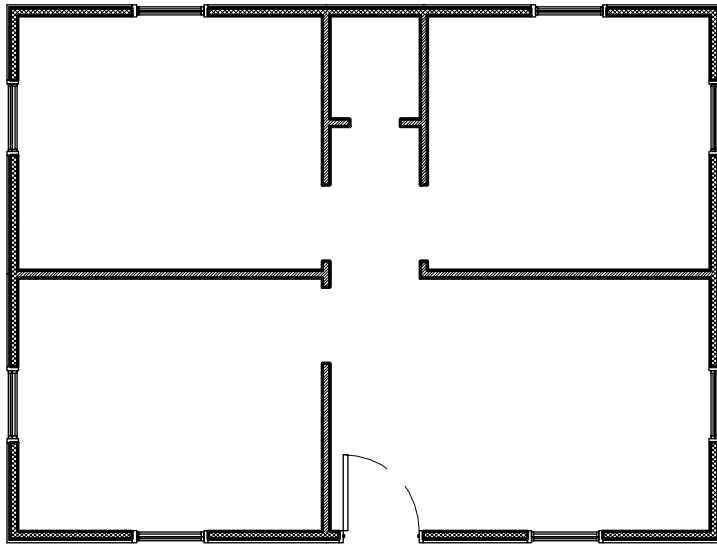

Figure D28 –The floor plan for the American small house shows four small rooms and a door placed at the center of the front façade.

D. Historic District Character – Types

Ranch House

Although it has a number of subtypes, the ranch house is characterized overall by its long and low one-story plan and an interior that divides spaces into two zones: the open, public family spaces, including the kitchen, and the enclosed, private, individual rooms. Fireplaces, chimneys, and carports or garages can be major architectural features. This house type first arrived in Georgia in the 1940s and was prevalent throughout the 1950s. Ranch houses can be found in Stone Mountain’s commercial areas, the residential area anchored by East and West Mountain Street, and Shermantown.



Figure D29–This is one example of the ranch house found on VFW Drive.

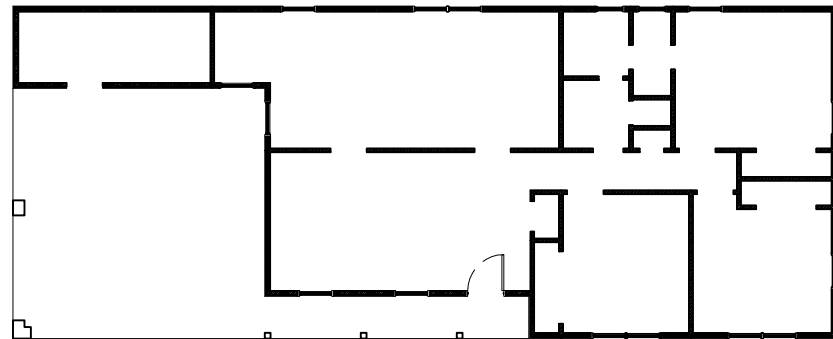

Figure D30 – The typical floor plan for a ranch house is long and narrow and often includes some type of porch or patio.

D. Historic District Character – Types



Figure D31 – This example of a one-part commercial block is on Main Street.

One-Part Commercial Block

The one-part commercial block, historically used as a commercial retail space, is a simple, box-shaped building with a decorated storefront façade. It has a flat roof, large display windows, a prominent entrance, and a cornice. It developed during the mid-19th century. The one-part commercial block can be found in Stone Mountain’s commercial character area.

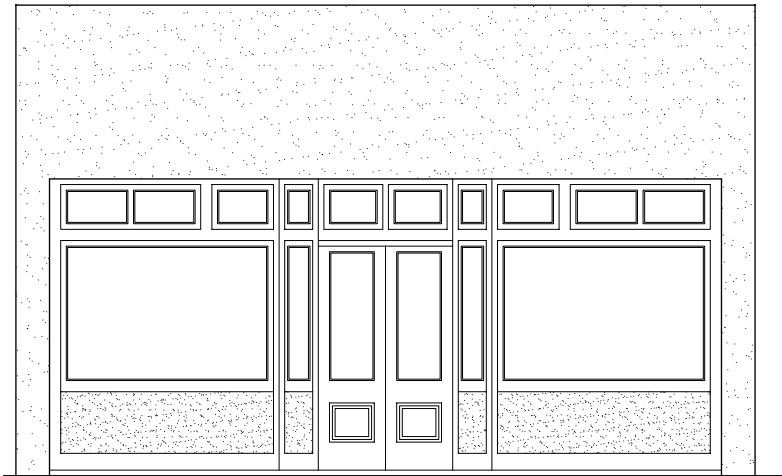

Figure D32– This elevation view of the one-part commercial block illustrates the typical elements found in the type.

D. Historic District Character – Types

Two-Part Commercial Block

The two-part commercial block is a building of two to four stories in height. The type is distinguished by a horizontally divided façade with two different characters. The single-story, lower part of the façade indicates a public, ground level storefront, while the upper levels, with rows of windows, give the impression of more private spaces like offices or apartments. These commercial building types were prevalent in the United States from 1850 to 1950. The two-part block can be found in Stone Mountain's commercial character area.



Figure D33 – This two-part commercial block example is one of a handful that can be found along Main Street.



Figure D34 – This two-part commercial block elevation view shows typical components.

D. Historic District Character – Types



Figure D35 – This is the only example of the arcaded commercial block in Stone Mountain and is found on East Mountain Street.

Arcaded Commercial Block

Defined by an uninterrupted row of arched window and door elements, the arcaded commercial block may be two or three stories high. As in the two-part commercial block, the ground level of an arcaded commercial block serves as a public retail or office space, while the upper floors may be apartments or private offices. This commercial building type was prevalent in the first three decades of the 20th century. The arcaded commercial block can be found in Stone Mountain’s commercial character areas

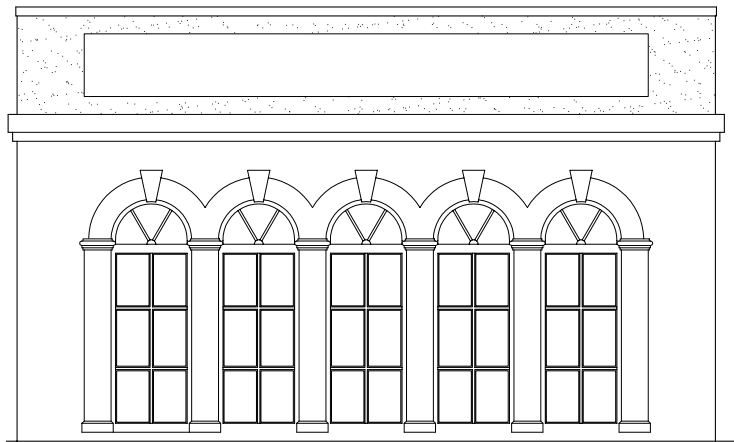

Figure D36 – This elevation view of an arcaded commercial block shows the typical elements associated with the type.

D. Historic District Character – Types

One-Story Community Store

The one-story community store resembles a house in its size, shape, and pitched roof. This freestanding building is not found in Stone Mountain's commercial centers, but on street corners in Shermantown. It typically features one large room where goods are displayed.



Figure D37 – This is an example of the one-story community store found at the corner of 4th and Venable streets.

D. Historic District Character – Styles



Figure D38 – This house on East Mountain streets has elements of the Georgian style such as a transom light above the door and double-hung windows with multiple, small panes of glass.

> D.2.b Architectural Styles

Georgian (1750-1810)

Georgian architecture, named for the Hanoverian kings of England (George I through George IV), was dominant during the 18th century in the British colonies along the eastern seaboard. Drawing from ancient classical Roman design and the English Renaissance architecture of the 17th and 18th centuries, Georgian style buildings were constructed from about 1750 to 1810.

Aspects of the style include symmetry in a rectangular form with a central entrance and symmetrically placed windows to either side. The style uses bold, big features such as heavy columns and pediments based on classical details. The entrance is emphasized by a transom and crown supported by pilasters or columns surrounding the door. Windows are double-hung, typically with many small panes (often nine-over-nine). The classical cornice is emphasized with a row of dentils or other decorative molding. The roof is steep, either tall and hipped or side-gabled. Georgian style buildings can be found in the residential area anchored by East and West Mountain Street.

D. Historic District Character – Styles

Greek Revival (1840s-1860s)

Prevalent in Georgia after the 1840s, the Greek Revival style developed from a renewed interest in the archaeological antiquities of ancient Greece and Rome and was a clear departure from English and other European Renaissance traditions. This revival drew directly from the original source and became thought of as a national style, used extensively throughout the United States.

The Greek Revival style is characterized by full-height, prominent columns, pilasters, and wide, plain entablatures that encircle a house. It features large, severe proportions. It is also characterized by a large, symmetrical block with a symmetrical front façade and central entrance. The door surround is elaborate, containing a rectangular transom, sidelights and pilasters. In Georgia, Greek Revival buildings often have low-pitched, hipped roofs supported by columns to form a full-width porch. Vernacular variants, with simplified details like round or square columns, are common. Windows are double-hung with six-over-six panes. Almost all Greek Revival houses were painted white. The Greek Revival style can be found in the residential area anchored by East and West Mountain streets.



Figure D39 – This is an example of a Greek Revival style house found on Ridge Avenue. The two-story columns, small porch over the door, side lights, and transom light over the door are all elements of the style.

D. Historic District Character – Styles



Figure D40 – This house on East Mountain Street has elements of the Italian Renaissance Revival style. The large, block massing of the house as well as the low-pitched roof and over-hanging eaves are elements of the style.

Italianate (1850s-1870s)

Popular and often found in Georgia cities during the 1850s and 1870s, the Italianate style originated in England and draws its influences from Italian country farmhouses and villas. It was popularized by Andrew Jackson Downing's publications on landscapes and architecture.

The style's distinguishing features are asymmetry, the use of an irregular (often L-shaped) plan, an emphasis on height and verticality, low-pitched hipped roofs, widely overhanging boxed eaves, and decorative brackets. Windows are typically tall and narrow, and porch supports may be slender columns or posts separated by sawn decorative brackets. Italianate houses sometimes incorporate square towers, cupolas, decorative corner quoins, and cornices with dentils. The Italianate style can be found in the residential area anchored by East and West Mountain Street.

D. Historic District Character – Styles

Queen Anne (1880s-1910)

The Queen Anne style is Georgia's most popular 19th century style. Developing in England, it drew its design from late medieval Elizabethan and Jacobean sources, and houses were often designed after large country manor houses. Queen Anne houses in the United States were wood-frame buildings built from the 1880s to about 1910.

Asymmetry, complex roof and wall shapes, and the use of projecting bays characterize the style, which is also known for its common wrap-around porch. The style incorporates a variety of textures, materials, and detailing, which are generally a combination of medieval and classically inspired features. Slender turned posts, sawn brackets, spindlework friezes, patterned shingles, and other ornamentation are common, and some examples incorporate more classically inspired details. The interior plan tends to be open and flowing. Roofs are often steeply pitched and hipped with both front- and side-facing, or cross, gables. Windows tend to be one-over-one, but some may have a multi-paned border around the top sash. Queen Anne style buildings can be found in the residential area anchored by East and West Mountain Street.



Figure D41 – This is an example of a Queen Anne style house located on Sheppard Road. Note the asymmetry of the façade, the shingles in the gables and the detail in the wood trim.

D. Historic District Character – Styles



Figure D42 - This Folk Victorian style house, located on Forrest Avenue, has elaborate scroll work which is like that of the Queen Anne style, but is more fragile and elaborate.

Folk Victorian (1870s-1910s)

The Folk Victorian style, derived from the elaborate styles of Queen Anne, Italianate, and sometimes Gothic Revival, lends a hint of stylistic detail to otherwise simple vernacular. It is more of a means of decorating a house than a precise stylistic category and is found throughout the state in both urban and rural communities.

Usually decorating a gabled ell, central hallway, or I-house, the Folk Victorian adds decorative details, usually turned or jigsawed woodwork to the porch, in the gables, and around the windows and door openings. The Folk Victorian style, though it incorporates Queen Anne elements, distinguishes itself from the Queen Anne style in that the house types it decorated tended to have symmetrical facades without the attention to varied wall surfaces characteristic of the other style. Folk Victorian style buildings can be found in the commercial corridor and in the residential area anchored by East and West Mountain Street.

D. Historic District Character – Styles

English Vernacular Revival (1920s-1930s)

Common in the early 20th century in Georgia's suburban neighborhoods, this style was derived from the domestic, country and vernacular architecture of medieval England. It is perhaps best identified by the use of a dominant, steeply pitched front-facing gable, the interior of which is decorated by half-timbering. English Vernacular Revival houses typically have masonry or masonry-veneered walls, some incorporating patterned brickwork and others completely stuccoed. A variety of materials can be used, such as brick walls with stone trim, wood half-timbering, and stuccoed gables. The use of massive masonry chimneys with decorative tops is common. Windows, casements rather than double-hung, are generally tall and narrow, grouped together, and multi-paned. This style is usually asymmetrical. English Vernacular Revival style buildings can be found in the residential area anchored by East and West Mountain Street.



Figure D43 - This house on East Mountain Street is in the English Vernacular Revival style. The large masonry chimney, as well as the arched openings, are elements of the English Vernacular Revival style.

D. Historic District Character – Styles



Figure D44 - This is an example of a Craftsman style house found on East Mountain Street. The large, overhanging eaves, brackets and double-hung windows with a multi-paned sash over a single-pane sash are elements of the style.

Craftsman (1910s-1930s)

The Craftsman style, originating in California and influenced by Japanese woodwork and the English Arts and Crafts movement, was Georgia's most popular early 20th century style. Craftsmanship and materials were the style's greatest emphasis. This style was popularized by extensive coverage in magazines and its prevalence in plan books.

A variety of materials constitute both the building and the decoration of a Craftsman house. Its roof is low-pitched and gabled (or occasionally hipped) with a wide, unenclosed eave overhang. The roof rafters are usually exposed. Large gables, sometimes decorated with half-timbering, have decorative brackets or braces at the eaves. Craftsman style houses may have full- or partial-width porches, with a roof supported by tapered square columns set on heavy masonry piers. They are usually asymmetrical with a generally open plan. This style is most closely, but not exclusively, associated with the bungalow. Craftsman style buildings can be found in the commercial corridor and in the residential area anchored by East and West Mountain Street.

E. Design Guidelines for Existing Buildings

To assure that the historic character in the Stone Mountain Historic District is maintained, it is necessary to establish guidelines for the rehabilitation and maintenance of its existing historic buildings. These guidelines, based on the U.S. Secretary of the Interior’s Standards for Rehabilitation (see page 2), advocate the careful maintenance of historic buildings and the use of historically appropriate design and replacement materials when necessary.

The Secretary of the Interior’s Standards for Rehabilitation defines “rehabilitation” as “the process of returning a property to a state of utility, through repair or alteration, which makes possible an efficient contemporary use while preserving those portions and features of the property which are significant to its historic, architectural, and cultural values.” The Standards assume some alteration and repairs to a building for contemporary use, but say “these repairs and alterations must not damage or destroy materials, features or finishes that are important in defining the building’s historic character.”

Although rehabilitation is sometimes necessary to preserve a building, the easiest way to protect

and preserve a historic structure is through routine maintenance. Maintenance should be performed by the gentlest means possible and as unobtrusively as possible, and it should not alter the main, visible façades of a building. According to the Standards, “protection includes the maintenance of historic material through treatments such as rust removal, caulking, limited paint removal, and re-application of protective coating; the cyclical cleaning of roof gutter systems; or installation of fencing, protective plywood, alarm systems and other temporary protective measures.” Routine maintenance does not require an application to the Stone Mountain Historic Preservation Commission for a certificate of appropriateness, but a property owner is encouraged to check with the HPC to determine if the intended work is considered routine maintenance.

The following guidelines will outline recommended and not recommended means of rehabilitating and maintaining historic buildings, emphasizing the use of appropriate materials and design and the maintenance of historic architectural elements and façades.

E. Design Guidelines for Existing Buildings - Commercial

E.1 – Commercial Buildings

In the City of Stone Mountain, historically commercial buildings and community stores as well as formerly residential buildings serve commercial functions. However, rehabilitating and maintaining these buildings should be done in a manner sensitive to each building's historic character. This section pertains specifically to buildings of a historically commercial design. **Residential buildings adapted for commercial use, which retain their residential character, should refer to the residential guidelines** beginning on Page 71.

> E.1.a – General Design

The design of a commercial façade often includes recessed entrances, tiled entryways, historic painted signs, and double doors. In the Stone Mountain Historic District, commercial façades may be one or two stories, with a ground level storefront and rows of windows denoting private spaces above. The most common material is load-bearing masonry of brick or granite. Commercial façades may have decorative elements, such as arched windows, decorative cornices and other brickwork, quoins, and pedimented front façades.

E.1.a.1. – Maintain historic elements of architectural character

When rehabilitating a historically commercial building, it is important to retain as much of the historic character as possible. This includes retaining the form, materials, and decorative elements of the building. Where historic materials have deteriorated, replacing them in kind rather than using a modern material is generally recommended. Historic storefronts should be repaired rather than replaced.

E. Design Guidelines for Existing Buildings - Commercial

E.1.a.2. Maintain altered façades whose alterations have gained their own significance

The rehabilitation of a storefront or commercial façade requires sensitivity. Sometimes historic façades have been “modernized” with the use of a false covering. In these cases, the removal of inappropriate, non-historic cladding, false mansard roofs, and other later alterations can reveal the historic character of a commercial façade. However, especially in commercial construction, historic façades may have gone through other types of past renovations that have become historically significant themselves. In these cases, reversing the façade to its initial configuration may not be appropriate.



Figure E1 - The general design of the historic storefronts in Stone Mountain includes a recessed front door with large display windows and transom lights above the windows and door.

E. Design Guidelines for Existing Buildings - Commercial

> E.1.b – Materials

Trends in prevalent building materials have changed over time. In a historic district, the use of historically compatible materials—that is, materials that would have been used at the time of a particular building’s construction—is important. This consistency helps to assure that buildings and districts maintain their historic integrity.

Wood

Commercial structures should retain wooden features.

Recommended:

- Identifying, retaining, and preserving historic wooden elements
- Replacing deteriorated elements in kind
- Protecting wooden elements from moisture with protective coatings and proper drainage

Not Recommended:

- Replacing all historic wood, rather than exclusively the wood that has deteriorated
- Stripping historically painted wood of its protective finish
- Removing or changing a building’s defining wooden features

Masonry

Load-bearing granite and brick are the most common masonry materials found in Stone Mountain’s historically commercial structures.

Recommended:

- Cleaning masonry by the gentlest means possible, such as low pressure water and detergents, using natural bristle brushes
- Repairing masonry by patching, piecing-in, or consolidating the masonry
- Replacing only extensively deteriorated masonry
- Repointing masonry with mortar of an appropriate color and material as well as joints consistent with the historic masonry

Not Recommended

- Removing historically significant masonry features from a building
- Replacing or rebuilding a historic masonry wall when it could have been repaired
- Removing paint from historically painted masonry
- Replacing mortar with mortar of a high Portland cement content where it was not historically used

E. Design Guidelines for Existing Buildings - Commercial

> E.1.c – Doors

The door, as the entrance and focal point of a building, is important to its historic character. Historically, doors were often specifically designed for individual buildings, and doors are therefore character-defining features. In the commercial area, most doors are single paneled or glass. Others exhibit a pair of double paneled doors with transom windows. They were made primarily of wood, with a glass pane in the upper half of the door.

Recommended

- Protecting and routinely maintaining historic doors and openings
- Repairing historic doors rather than replacing
- Maintaining size and materials when replacing deteriorated historic doors
- Adding storm and screen doors so that they do not obscure the original design of the historic door

Not Recommended

- Creating additional bays
- Enclosing or relocating door openings
- Installing veneered or hollow doors due to threats of warping and veneer separation



Figure E2 – Historic doors in the commercial character area of Stone Mountain are made of wood and most are at least half glass. Historic doors should be maintained.

E. Design Guidelines for Existing Buildings - Commercial



Figure E3 - There are multiple types of non-display windows within the Stone Mountain commercial character area. Multi-light, double hung types are most common, as can be seen on the two-story brick building in this photo.

> E.1.d – Windows and Fenestration

Windows and fenestration, or the design and character of windows and other exterior openings, are important character-defining features of a building. Improper fenestration may include the creation of new or larger openings, which disrupts a building's historic character, and the use of historically inappropriate windows. In the Commercial Area, most windows are four-over-four double hung windows. Others are one-over-one double hung windows, and fixed light windows.

Recommended

- Protecting and maintaining historic materials which comprise the window frame, sash, muntins, and surrounds through appropriate surface treatments such as cleaning, rust removal, limited paint removal, and re-application of protective coating systems
- Patching, splicing, consolidating or reinforcing in repair of historic window frames and sashes
- Replacing in kind those parts that are either extensively deteriorated or are missing when there are surviving prototypes such as architraves, hoodmolds, sash, sills, and interior or exterior shutters and blinds

E. Design Guidelines for Existing Buildings - Commercial

- Maintaining materials including frames, sashes, and muntins when replacing deteriorated historic windows
- Configuring replacement windows to be compatible with the building's historic appearance

Not Recommended

- Changing the historic appearance of windows with inappropriate designs, materials, finishes, or colors, which radically change the sash, depth of reveal, muntin configuration, reflectivity and color of the glazing, or the appearance of the frame
- Using vinyl or aluminum-framed windows

E. Design Guidelines for Existing Buildings - Commercial



Figure E4 - The roofs of Stone Mountain's historic commercial buildings tend to be built-up or of tar and gravel. These materials should be repaired rather than replaced when maintaining the historic building.

> E.1.e – Roofs

The roof is the most apparent place to notice improper and non-historic changes. Not only are historically appropriate materials important to the character of the roof, unregulated contemporary elements, such as skylights, can be historically inappropriate. Also, only certain roof types are appropriate for architecture found in a district.

Recommended

- Maintaining the original shape and pitch of the roof with original features and materials
- Repairing historic roofing materials rather than replacing
- Installing new roofing material with compatible texture, color, design, and composition to the historic roofing material
- Retaining historic gutters and downspouts
- Replacing deteriorated gutters and downspouts with those similar in material and appearance to the originals
- Installing new gutters and downspouts in an unobtrusive manner

Not Recommended

- Installing Ogee (or K-Style) gutter or rectangular downspouts on a building constructed prior to 1950

E. Design Guidelines for Existing Buildings - Commercial

> E.1.f – Awnings

An awning can affect the outward appearance of a historic building. Awnings can be historically accurate amenities to a storefront, but they can also be intrusive, inappropriate modern additions that significantly diminish a storefront's integrity. It is therefore important to make sure that awnings are compatible with the district's character and do not obscure or damage any historic features.

No historic awnings existed in the commercial area of the City of Stone Mountain therefore it is difficult to say what they may have looked like. If pictorial evidence is found for a historic awning, this should be the basis for design and location of a replacement awning.

Recommended

- Protecting and maintaining historic awnings that are character-defining to the commercial building
- Installing free-standing awnings that do not impede pedestrians by attaching to the sidewalk in any way
- Replacing an original historic awning that is missing by restoration and only when historical, pictorial, and physical documentation exist
- Using photographic evidence as the basis for design of an awning replacing one that historically existed



Figure E5 - Awnings such as this should be maintained and repaired, rather than replaced when they exist on historic commercial buildings in Stone Mountain.

E. Design Guidelines for Existing Buildings - Commercial

- Using photographic evidence of historic awnings if possible to determine the awning size, stripe pattern, valance type, and lettering
- Installing an awning that does not obscure or alter distinctive features
- Installing an awning that does not damage the historic fabric or historic materials of a building
- Installing an awning that does not change the historic character of a building
- Installing an awning compatible with the features and characteristics of the historic building
- Installing a rounded awning only when attached door or window openings dictate such a design
- Installing awnings only above windows or doors
- Attaching an awning below the storefront cornice or sign panel so that it does not cover the piers on either side of the storefront
- Building an awning onto a metal frame
- Making an awning of canvas, canvas blend, acrylic that resembles canvas, or acrylic blend that resembles canvas
- Making an awning a single color or with a striped pattern appropriate for the historic commercial area
- Using awnings for signage and following the design guidelines for signage when doing so
- Limiting an awning used as signage to two colors
- Following the City sign permitting process when installing an awning that will be used as signage

Not Recommended:

- Installing an awning that obscures or alters distinctive features of a building
- Installing an awning that damages the historic fabric or historic materials of a building
- Installing an awning that changes the historic character of a building
- Installing a rounded awning when the door or window openings do not dictate such a design
- Making awning of metal, plastic, wood, or vinyl
- Making an awning anything other than a solid color or striped pattern
- Installing awnings that are illuminated from within

E. Design Guidelines for Existing Buildings - Commercial

> E.1.g – Balconies

A balcony can be an important element of any commercial building. This is another example of an element that can be, depending on its design, historically appropriate while also being contemporary and intrusive.

Recommended

- Replacing an original historic balcony with an accurate restoration when historical, pictorial, and physical documentation is available, or a new design that is compatible with the design and historic character of the building
- Adding a new balcony on the rear or on an unobtrusive façade of a building as long as it complies with local ordinances and codes
- Painting or treating a balcony with an appropriate surface treatment

Not Recommended

- Constructing balconies that obscure significant character-defining features of a historic building
- Using unpainted, pressure treated lumber or composite materials for a balcony

E. Design Guidelines for Existing Buildings - Commercial



Figure E6– This air conditioning unit has been installed on the rear of the building, where it is not visible and does not obstruct the façade of the historic commercial building.

> E.1.h – Appurtenances

Appurtenances are a property’s accessories. Examples include utilities, steps, light fixtures, accessibility elements, and signage. Historically inappropriate appurtenances can disrupt a neighborhood’s historic character if not placed as inconspicuously as possible.

Recommended

- Screening HVAC units with wood fences, lattice panels or evergreen shrubs where visible
- Recessing rooftop HVAC from front and side facades with minimal visibility from street
- Installing singular exterior lighting
- Installing accessibility ramps on an unobtrusive façade
- Screening accessibility ramps with shrubs or fencing when they can be seen from the primary façade

Not Recommended

- Placing window air conditioning units on front or side facades
- Installing solar devices, mechanical systems and utilities on the roof or visible from the front façade
- Installing new appurtenances with reflective or bright surfaces

E. Design Guidelines for Existing Buildings - Commercial

> E.1.i – Storefront Design

Storefronts often are the most important defining feature of historic commercial buildings. Historically, storefronts were carefully designed to maximize display area, allow light into the store, and attract customers using windows, doors, transoms, and other architectural detailing.

Recommended

- Protecting and maintaining historic character-defining features of storefronts such as windows, transoms, doors, decorative details, and materials through appropriate treatments such as cleaning, rust removal, limited paint removal, and reapplication of protective coating systems
- Maintaining the location of a storefront's main entrance
- Repairing deteriorated storefronts by reinforcing historic materials and by replacing historic materials with in-kind materials or with compatible substitute materials
- Using replacement materials that are compatible in size, scale, composition and design to the storefront



Figure E7 - The original materials, door location and general design of this commercial storefront have been maintained, which is recommended for historic storefronts in Stone Mountain.

- Removing non-historic cladding, false fronts, or inappropriate additions to historic storefronts in order to reveal the historic character of the building

Not Recommended

- Covering character-defining elements of storefronts with non-historic cladding, false fronts or inappropriate additions
- Altering a historic commercial storefront so that it appears to be residential in character

E. Design Guidelines for Existing Buildings - Commercial



Figure E8 – This historic commercial building sits on a corner and therefore has at least two facades with historic characteristics that should be maintained.

> E.1.j – Corner Building

A corner building in a commercial character area has more than one façade facing the public right-of-way. It is important to apply the design guidelines to all facades visible from the right-of-way in order to retain and emphasize historic character.

Recommended

- Protecting and maintaining historic character-defining features of corner buildings such as windows, transoms, doors, decorative details and materials through appropriate treatments such as cleaning, rust removal, limited paint removal, and reapplication of protective coating systems
- Removing non-historic cladding, false fronts, or inappropriate additions to historic corner buildings in order to reveal the historic character of the building

Not Recommended

- Covering character-defining elements of historic corner buildings with non-historic cladding, false fronts or inappropriate additions

E. Design Guidelines for Existing Buildings - Residential

E.2 – Residential Buildings

Design guidelines serve to assist property owners, architects, and contractors in the application process for a COA as well as throughout the rehabilitation process. They are utilized by the Stone Mountain (HPC) in evaluating how rehabilitation will affect and impact the entire historic district and its character. Appropriate rehabilitation of existing residential structures protects the historic character and significance of the structure while adapting it for present use.

> E.2.a – General Design

Preservation of character-defining elements of historic buildings is a top priority; alterations and repairs should accurately represent the historic qualities of the building. Historic documentation should be used for rehabilitation work whenever possible. Where documentation is not available, interpretations of similar elements that existed in the area may be considered.

A certain amount of time must pass before the historic significance of a property can be evaluated. The National Register of Historic Places, for example, suggests that a property be at least 50 years old or have extraordinary importance before it may be considered for listing.

Every historic resource has a period of significance, or the time span during which it gained architectural, historical, or cultural importance. In addition to being historically significant, a property must have integrity, meaning that a sufficient percentage of the structure must exhibit characteristics from its period of significance. Historic materials contribute to the historic fabric of a structure and should be preserved.

E. Design Guidelines for Existing Buildings - Residential



Figure E9 - This house on East Mountain Street has been well maintained to retain the historic nature of its general design, materials, doors, windows, porch, and roof.

E.2.a.1 – Maintain historic elements of architectural character

It is important to identify, retain, and preserve the form and detailing of architectural materials and features that define the historic character of residential buildings. When possible, the best use for historic buildings is their intended use.

Historic materials and architectural elements should be repaired instead of replaced when possible; should replacement of a deteriorated material be required, it should be “in kind” and should affect as little historic material as possible.

It is essential first to protect and maintain historic materials and features; second, repair them if additional work is required; and third, only replace an entire character-defining feature with new material if extensive irreparable damage or deterioration has occurred.

The primary objectives should be to provide for preservation of all important character-defining architectural materials and features of a building and to make provisions for a safe and efficient contemporary use.

E. Design Guidelines for Existing Buildings - Residential

E.2.a.2 – Maintain additions and alterations that have gained their own significance

Historic additions represent a physical record of the evolution of a structure and should be respected as valuable in their own right. Many historic houses have been altered over time, as design tastes changed or additional space was needed, and these changes serve as evidence of the history of the building and neighborhood.

Many early alterations were subordinate in scale and character to the main building. Alterations were often executed using materials that were similar to those used originally. Some early alterations may have taken on historic significance of their own.

An addition constructed in a manner compatible in scale, materials, and placement with the original building that is associated with its period of significance may merit preservation on its own. More recent alterations that are not historically significant may be removed.

E. Design Guidelines for Existing Buildings - Residential

> E.2.b – Materials

Trends in prevalent building materials have changed over time. In a historic district, the use of appropriate historic materials—that is, materials that would have been used at the time of a particular building’s construction—is important. This consistency helps to assure that buildings and districts maintain their historic integrity.

Only exterior materials are regulated: the HPC does not regulate the interior of buildings. Also, materials that are visible from the public right-of-way, and particularly on the front façade, are the most significant. Materials in less prominent locations remain under the jurisdiction of the HPC, but are assessed with greater flexibility. Also, ordinary repair and upkeep of materials, such as painting a previously-painted surface, does not require a COA, although it is recommended that property owners contact the HPC before beginning work if there is any question as to whether or not their proposed work constitutes ordinary maintenance.

It is also important to remember that synthetic materials, such as fiber cement siding, may not be acceptable on projects that are applying for tax

incentives or credits. Please refer to section A4 for further information on historic rehabilitation tax programs.

Within the architecturally high-style residential area anchored by East and West Mountain Streets, the most common exterior materials are brick, granite, and wood. Brick is commonly used not only as a wall and façade material, but for foundations as well, some of which are simply brick piers. Brick is also the most common material used in historic chimneys, which are defining features of houses in this area.

Granite is a prevalent foundation material, and is usually used in solid wall foundations, some of which have been painted. Granite is also used decoratively in such elements as columns and entrance steps, and is found as the structural material for the walls of some houses: these walls are sometimes covered with historic stucco, a practice that represents usage of local materials and techniques and is a unique feature of some historic Stone Mountain buildings. Finally, wood is found most often as siding and trim, such as porch railing, but is also present as shingles, most often found as decorative elements of gables. Metal is also found

E. Design Guidelines for Existing Buildings - Residential

within the area. Examples of metal usage include historic hardware and cast-iron porch railing.

Within Shermantown, brick, stone, and wood are the most common exterior materials. Brick is commonly used as a foundation material and also as chimney material. Some houses in this area, such as ranches, are constructed with a brick veneer. Stone is also present, both in pier foundations, some of which have been reinforced and filled-in with other materials, and as solid-wall foundations. The prevalent type of stone is granite. Finally, the use of wood is a character-defining feature of these buildings. Horizontal wood siding is the most common exterior material in the area. Wood is also used for trim.

Wood

Recommended

- Repairing historic materials, when feasible. Often, epoxy can be used to repair deteriorated wood, thereby retaining historic fabric
- Spot-replacing deteriorated wood with in-kind material, if replacement is necessary. If siding is failing, the deteriorated portions should be replaced if irreparable, while the intact historic siding material is retained

- Replacing “in kind” by using replacement materials that are compatible with historic fabric
- Using replacement material that matches the scale, design, texture, and appearance of the historic material
- Replacing wood with fiber cement siding, when appropriate
- Using materials that are historically appropriate to the specific style and type of building on which work is being completed

E. Design Guidelines for Existing Buildings - Residential



Figure E10 - The use of apparently historic elements to make a building look older than it is is not appropriate. This colonial-style door would not be appropriate in Stone Mountain, which does not have any examples of Colonial architecture.

Not Recommended

- Replacing original material that could be repaired
- Covering wood siding with newer material
- Using aluminum or vinyl siding
- Using materials that are not historically appropriate to the specific style and type of building on which work is being completed
- Stripping historically painted or finished wood
- Removing historically-significant wooden features from a building
- Using any material that creates a false sense of history by attempting to make a building appear older than it actually is

Masonry

Recommended

- Repairing, by means of patching or reinforcing, original materials, when feasible
- Retaining historic foundation fabric whenever possible
- Repointing failing mortar joints with historically appropriate material that will not damage the historic foundation and respects historic construction techniques
- Duplicating historic mortar joints in profile and width

E. Design Guidelines for Existing Buildings - Residential

- Repairing historic masonry, when necessary, with material that matches the color, size, shape, texture, and appearance of the historic foundation material
- Enclosing the spaces between the piers of pier foundations with wood lattice in a 45 or 90 degree pattern, recessed behind the original foundation and removable without damaging the historic fabric
- Reinforcing foundations (enclosing the spaces between the piers of pier foundations) with structural material only when necessary to stabilize the building. This material should be compatible, but not identical, and recessed behind the historic foundation fabric
- Cloaking latticed foundations with appropriate plantings
- Maintaining paint on historically painted foundations
- Cleaning masonry with the gentlest means possible
- Reinforcing a foundation in a way that does not maintain a visual distinction between the historic foundation and new materials (for example, enclosing the spaces between pier foundations without recessing the new material from the historic fabric)
- Painting a historically-unpainted foundation
- Using Portland cement or other synthetic materials to repair historic masonry foundations that were not initially constructed with synthetic materials

Not Recommended

- Replacing the foundation without first thoroughly investigating repair options
- Enclosing the spaces between the piers of pier foundations with solid material if not necessary to stabilize the building



Figure E11 – Painting brick that was historically unpainted diminishes the historic integrity of the material and associated building and is not recommended.

E. Design Guidelines for Existing Buildings - Residential

- Using synthetic masonry materials
- Utilizing EIFS (Exterior Insulation and Finishing Systems)
- Removing historically-significant masonry features from a building
- Using any material that creates a false sense of history by attempting to make a building appear older than it actually is
- Cleaning masonry with harsh chemicals or processes, such as sandblasting
- work is being completed
- Removing historically-significant metal features, such as flashing or ornament, from a building
- Applying any material that creates a false sense of history by attempting to make a building appear older than it actually is
- Cleaning metal with harsh chemicals or processes, such as sandblasting

Metal

Recommended

- Repairing, by means of patching or reinforcing, original materials, when feasible
- Retaining historic foundation fabric whenever possible
- Performing regular maintenance and condition inspections. This is critical for metal elements, which deteriorate easily as a result of rust and corrosion.
- Maintaining paint on historically-painted metal

Not Recommended

- Replacing original material that could be repaired
- Using materials that are not historically appropriate to the specific style and type of building on which

E. Design Guidelines for Existing Buildings - Residential

> E.2.c – Doors

The door, as the entrance and focal point of a building, is enormously important to its historic character. Care should be taken not to install doors that are inappropriate and disrupt the appearance of the overall character of the house.

Recommended:

- Preserving historic doors and surrounding decorative features
- Replacing doors and surrounding decorative features only in circumstances when the original or historic entrance is in a state of extreme deterioration
- Installing a replacement door that is appropriate in design and does not deviate more than one inch in size from the original door opening
- Preserving historic doors that have been grained or stained except in exceptional circumstances
- Providing the greatest possible view of the main door, when installing security doors, with a minimal frame



Figure E12 - The door on this historic house has been replaced with a more modern door that has multiple panes of glass. This is not compatible with the historic nature of the house and is not recommended

Not Recommended:

- Filling in historic door openings
- Installing screen doors and storm doors that do not match the proportions and design of the doors
- Installing replacement doors that are inappropriate for the style and materials of the house
- Filling in surrounding decorative features, such as sidelights and transoms
- Installing security or storm doors that significantly obscure the door on a primary entrance
- Creating new door openings on a primary facade

E. Design Guidelines for Existing Buildings - Residential



Figure E13 - This house's historic windows exhibit storm windows that do not interrupt or conceal the historic glazing pattern.

> E.2.d – Windows and Fenestration

Windows and fenestration, or the design and character of windows and other exterior openings, are important character-defining features of a building. Improper fenestration may include the creation of new or larger openings, which disrupts a building's historic character, and the use of historically inappropriate windows.

Recommended:

- Maintaining and preserving historic windows whenever possible
- Using materials in the replacement of windows that possess the same visual qualities of the historic windows
- Installing replacement windows of an appropriate design, light configuration and style in regards to the window's decorative surrounds, sill, moldings, and lintel
- Maintaining an appropriate style and design of decorative glass windows, most in keeping with the style and period of the house
- Returning an historic window opening, that has been enclosed, reduced, expanded, or concealed, to its original appearance
- Replacing glazing, in kind wherever appropriate

E. Design Guidelines for Existing Buildings - Residential

- Using storm windows of appropriate design that fit window dimensions and allows maximum visibility of the historic window by consisting of a single, continuous light of transparent material
- Preserving historic shutters
- Maintaining a functional appearance of shutters by utilizing an appropriate shutter size for the window
- Using appropriate shutter designs and materials in keeping with the style of the house

Not Recommended:

- Using materials or design that are inappropriate for the style of the house
- Installing windows that reflect an inappropriate design or style of the decorative surrounds, sill, moldings, and lintel
- Enclosing, reducing, expanding, or otherwise concealing an historic window opening
- Using storm windows with meeting rails that do not match with the meeting rails of the window
- Installing decorative glass windows in new openings or extant historic window openings, which have no historic evidence of having had decorative glass
- Attaching shutters that to a house that has no historic evidence of ever having had shutters
- Installing shutters that are inappropriately sized or constructed of inappropriate materials, such as vinyl



Figure E14 - The wood window of this historic house has been well maintained. The light pattern and materials have been retained although the glass appears to have been replaced with new material.

E. Design Guidelines for Existing Buildings - Residential



Figure E15 - The original configuration of this porch has been well maintained; no enclosures or additions have been made, allowing it to maintain its integrity.

> E.2.e – Porches

Porches are a major character defining feature of historic buildings. Porches have traditionally served as outdoor living space, a transition space between the public and private areas of a property, and as an architectural focus of the property, often richly embellished and emphasized. As one of the most significant character defining features of a building, the appropriate treatment of porches is imperative to buildings within historic districts.

Within the residential area anchored by East and West Mountain Street, porches are typically high-style, often exhibiting wood trim, such as scrollwork, railing, columns or brackets, and masonry accents, such as granite or brick foundations, steps or columns. They are often full-width across the front façade of a home. Many protrude from the front façade, and have various roof types, including flat, gabled, and hipped, while others are integral to the house, meaning that they are located under the main roof of the house and do not protrude from a façade. Porch style, type, location and ornament are largely determined by house type and style. As a general rule, younger

E. Design Guidelines for Existing Buildings - Residential

house types, such as the ranch and the American small house, have less prominent front porches if any at all.

Within Shermantown, porches are simpler and less stylistic. The vast majority are not full-width across the front façade of a house, but are instead positioned to one side of the façade or in the center, not extending full-width. Almost all protrude from the front façade, and have various roof types, including shed, gabled, and hipped. Porch style, type, and location are largely determined by house type and style: as a general rule, younger house types, such as the ranch and the American small house, have less prominent front porches if any at all.

Recommended:

- Retaining and maintaining historic porches and porch elements whenever possible
- Repairing rather than replacing historic materials of the porch, including ornamental and structural materials
- Replacing, only when absolutely necessary, deteriorated historic materials with in-kind, compatible materials. The new material(s) should match the old in design, color, type and texture, whenever possible
- Adding materials and elements, such as screen and storm doors, that do not detract from the porch's historic character
- Enclosing porches with transparent materials, such as single sheets of clear glass, and recessing this material behind the historic materials of the porch (such as columns and railing), in order to alter the porch's character as little as possible
- Referring to section E2b of these guidelines for information on infilling historic porch foundations
- Referring to section F2g for guidelines on the reconstruction of a historic porch that is no longer extant. In general, this is only appropriate with sufficient historic documentation to indicate what the historic porch looked like and where it was located on the house

E. Design Guidelines for Existing Buildings - Residential

Not Recommended:

- Removing or altering a historic porch. It is important to remember that even if a porch is not original to a house, it may have gained significance in its own right over time, in which case removal and alteration also would be inappropriate
- Enclosing a porch that is visible from the right-of-way with anything other than transparent materials, such as single sheets of clear glass. If glass enclosure is planned, the glass should be recessed behind the historic materials of the porch (such as columns and railing), in order to alter the porch's character as little as possible. Porch enclosure should also be reversible, which is to say that materials used to enclose a porch should be removable without causing further damage to the historic materials
- Adding materials, such as trim, lighting fixtures, and ornament, that are not appropriate to the style of the house of which the porch is a part
- Creating new entrances to porches or relocating historic entrances
- Altering the historic visual relationship between the porch and the house. For instance, raising the height of railing on a porch can block the view of historic house characteristics from the right-of-way

> E.2.f – Decks

Recommended:

- Constructing decks on non-character defining elevation of the property, usually on the rear of a building or in areas not visible from the street
- Designing and detailing decks and associated railings and steps to reflect the materials, scale, and proportions of the residence
- Aligning the deck with the height of the building's main level
- Setting the deck back from the original perimeter of the building to lessen the visual impact from the street
- Installing decks so that they are structurally self-supporting and may be removed in the future without damage to the historic structure
- Constructing decks in appropriate materials such as wood or composites
- Screening with compatible foundation materials or plantings to visually tie the deck to the building

Not recommended:

- Constructing decks that project or cantilever beyond the sides of the building
- Using vinyl for decks or railings

E. Design Guidelines for Existing Buildings - Residential

> E.2.g – Roofs

Roofs are the highest parts of a building and, like other character-defining features, among the most visible. Roof forms and chimneys for Stone Mountain’s historic residential structures should conform to those traditionally found in the district. Roofs should be gabled or hipped with the ridge running parallel or perpendicular to the street depending on lot shape and size.

Recommended:

- Constructing rooftop additions only visible from rear secondary streets and alleyways
- Installing additions in a manner that does not damage or visually obscure historic building fabric
- Designing rooftop additions and dormers appropriate to the scale and character of the historic building
- Using matching or complementary materials, forms, and detailing for roof replacements and rooftop additions and dormers
- Locating new dormers lower than the primary ridge-line and set in from the eave
- Adding new dormers that are appropriately scaled to maintain the dominant form of the original roof



Figure E16 – This house’s historic roof has been replaced with a standing-seam metal roof that is inappropriate in material for the house.

- Installing new gutters and downspouts where they have not existed historically if the gutters and downspouts will prevent damage to other building features such as masonry walls and trim
- Selecting gutter and downspout styles, materials, and layouts that are appropriate to the character of the building and minimize the visual impact to the historic structure
- Placing modern rooftop elements, such as mechanical units, ducts, solar panels, antennae, satellite dishes, and vents out of view from the street level or from adjacent buildings
- Incorporating new roof elements such as vents that are visually and physically compatible with the overall design of the historic structure

E. Design Guidelines for Existing Buildings - Residential

- Repairing or replacing chimneys using materials and design similar to other chimneys on the block face
- Installing low-profile skylights that are not visible from the street

Not recommended:

- Changing the pitch or configuration of the roof from what is historically appropriate
- Installing new dormers on primary elevations
- Placing skylights on a primary elevation, visible from the street
- Inserting “bubble”-style skylights

> E.2.h – Appurtenances

Appurtenances are like a property’s accessories. Examples include utilities, handicapped accessibility elements, and signage. Historically inappropriate appurtenances, such as a TV satellite dish, can disrupt a neighborhood’s historic character if not placed as inconspicuously as possible.

Utilities and Equipment

Recommended:

- Placing telephone, electrical, and television wires at the rear of the property or underground where possible
- Mounting meter boxes low on a side or rear wall of the residence
- Placing rooftop television antennae at the rear of the building out of view of the public right-of-way
- Installing air conditioning/heating units (including window units) on a side, rear or secondary wall of the residence
- Placing cables and wires, plumbing, heating/air conditioning units, television antennae, meter boxes, solar panels, and other utilities in locations with minimal impact on the streetscape

E. Design Guidelines for Existing Buildings - Residential

Not recommended:

- Placing cables and wires, plumbing, heating/air conditioning units, television antennae, meter boxes, solar panels, and other utilities where they visually dominate or damage the historic building
- Locating utilities, equipment and similar items on the front façade or any wall visible from the public right-of-way

Service Areas

Recommended:

- Locating service areas for trash and recycling containers, firewood, and maintenance equipment at the rear of the property whenever possible
- Screening service areas from view, using an appropriate fence, hedge, or enclosure

Not recommended:

- Placing service areas where visible from the public right-of-way

Accessibility

Recommended:

- Locating ramps on a side or rear entrance whenever possible
- Constructing ramps compatible with the scale and style of the building

- Using appropriate landscape elements to screen ramps or other features related to accessibility
- Incorporating details that complement but do not match exactly the original railings and balustrades of the building

Not recommended:

- Constructing ramps on the front entrance of the building



Figure E17 - A ramp has been added to this historic house, but it is located to the side of the main façade and it is screened with shrubs so it does not detract from the historic nature of the house.

F. Additions to Existing Buildings - Commercial

F.1 – Overview

Additions to contributing properties within the Stone Mountain Historic District are encouraged. Additions, however, should not detract from the historic character or integrity of either the property to which they are attached or the District, generally. These design guidelines are intended to facilitate additions that are appropriate for and compatible with the historic fabric of the Stone Mountain Historic District, using the Secretary of the Interior’s Standards for Rehabilitation as a blueprint. In general, additions to historic buildings should be compatible with the district and the historic building to which they are attached, but also differentiated enough to be distinguishable from the original building.

F.2 – Commercial Buildings

> F.2.a – Location

Location is one of the most important issues to consider when assessing the appropriateness of any planned addition. An addition that does not respect the historic character of a building will destroy the integrity of the building. In general, additions should never be placed on the front façade of a historic building. This placement destroys the historic appearance and character of a building, as the front façade is typically the most important.

Within the Stone Mountain Historic District’s commercial character area, the only feasible placement of additions on most buildings is on the rear facades, since the buildings adjoin one another. In the instances that a side façade of a commercial building is visible (such as on corner buildings), a side façade addition would not be recommended. The street-fronting side facades of these buildings were historically constructed to be secondary main facades, with the same amount of architectural detail and character as is found on the front. Rooftop additions are not permitted.

F. Additions to Existing Buildings - Commercial



Figure F1 - This addition is in a good location, as it is behind the main block of the building and slightly recessed, so as not to obstruct or detract from the view of the historic building.

Recommended:

- Placing additions on the rear facades of buildings, inset from each historic façade so as to clearly represent a new phase of construction

Not recommended:

- Placing additions on architecturally detailed facades meant to appeal to the public view, including all front and some side facades
- Constructing rooftop additions



Figure F2 - The location of this addition is not recommended, because it has been added to the primary/ front façade of the historic storefront.

F. Additions to Existing Buildings - Commercial

> F.2.b – Massing and Scale

A building's **massing** is its sense of bulk, density, and weight. Its **scale** refers to the proportionate way the building relates to its surroundings. An addition can be said to be “out of scale” when it is noticeably larger or smaller than its historic neighbors.

Massing and scale within the commercial character area of the Stone Mountain Historic District are typical of historic commercial areas. All buildings are rectangular and one to two stories in height. They are typically sited so that a one- or two-room wide front façade comprises the visual focus of the building. From that façade, the building stretches to the rear several rooms deep. Typically, these buildings have flat walls and are without projections, such as bay windows or balconies.

Recommended:

- Constructing additions that respect the historic scale of the original building
- Constructing additions that respect the historic massing of the buildings within the Stone Mountain commercial character area
- Designing and constructing additions in such a way that if ever removed, the essential form of the original building would remain intact

Not recommended:

- Constructing additions of incompatible scale with the historic building
- Constructing additions of incompatible massing with the historic building
- Constructing additions that alter the footprint of the historic building so much as to obscure the form of the original building

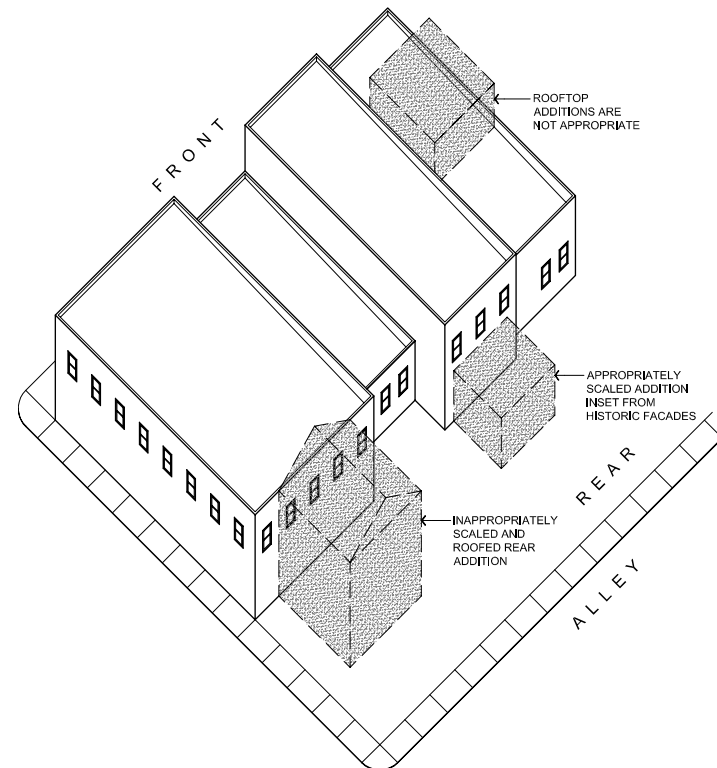

Figure F3

F. Additions to Existing Buildings - Commercial



Figure F4 - The general design of this addition is recommended because it can be differentiated from the original building and the design mimics enough of the design elements of the original building to be complementary.

> F.2.c – General Design

The Secretary’s Standards for Rehabilitation encourage additions that enable the public, upon visual examination, to “read” the building as one to which additions have been made. Additions should be easily identifiable as new construction. This can be done in many ways. An addition to a historic brick building could have a slightly different brick bond or type of brick. This variation is compatible with the historic building, but can be clearly interpreted as new, different construction. This eliminates confusion about whether the addition is historic.

Recommended:

- Constructing additions of which the general, overall design is differentiated from the historic building enough to be easily read as new construction
- Constructing additions that incorporate the above principle, while also exhibiting enough compatibility to be complementary to the historic building

F. Additions to Existing Buildings - Commercial

Not recommended:

- Designing additions to aesthetically “blend in” with the historic building to which they are attached, making it difficult to determine what elements of the building are and are not historic
- Constructing additions that are not complementary to the historic building
- Constructing additions that are dramatically different in materials, scale, massing, ornament or general appearance
- Including inappropriate architectural details or decorative elements such as door and window surrounds, brackets, and gingerbread on additions. If added, there must be a documented precedent, such as historic photographs or plans, showing these features on the building



Figure F5 - The general design of this addition is not recommended because it does not complement the historic building. The materials also are not recommended because they are not compatible with materials used in the historic building.

F. Additions to Existing Buildings - Commercial



Figure F6 - This is an example of a recommended addition because the materials are like that of the historic building but can be differentiated.

> F.2.d – Materials

Trends in building materials have changed over time. In a historic district, the use of appropriate historic materials—that is, materials that would have been used at the time of a particular building’s construction—is important. This consistency helps to assure that buildings and districts maintain their historic integrity.

Particularly in a District such as Stone Mountain, where the local availability of granite for building is so evident and significant, it is important that the materials used in additions respect and complement the original materials of the buildings they serve. The most prevalent materials in the commercial character area of the Stone Mountain Historic District are granite and brick. Because of the age of the buildings, these materials exhibit distinct characteristics, such as lime mortar and load-bearing masonry bonds. Often, even a building not constructed entirely of granite will have a granite foundation.

It is important to be aware of the significance of material usage when applying for historic tax credits and incentives, as these programs may render some more modern materials unacceptable.

F. Additions to Existing Buildings - Commercial

Recommended:

- Using materials that reflect, but do not attempt to duplicate, the fabric of the historic building
- Using the same type of material as used in the original building, although the material used should not exactly duplicate the historic material in appearance
- Designing and constructing additions to maintain as much of the original building's historic material as possible
- Constructing additions with wood or fiber cement siding

Not recommended:

- Using vinyl siding
- Using purely imitation materials, such as PermaStone, to give the appearance of stone or brick construction
- Using other incompatible materials, including concrete block and exterior insulation and finish systems (EIFS)
- Removing or destroying existing historic materials
- Using painted brick. Historically, the brick of the Stone Mountain commercial character area would not have been painted, except in special cases, such as the painting of advertisement on a visible façade



Figure F7 - The addition of an external insulation and finishing system (EIFS) to this historic commercial building is not recommended because it has masked historic materials.

F. Additions to Existing Buildings - Commercial



Figure F8 -This door is recommended because it uses materials that are complimentary to the historic doors in Stone Mountain and it does not detract from the historic nature of the building.

> F.2.e – Doors

The door, as the entrance and focal point of a building, is enormously important to its historic character. Historically, doors were often specifically designed for specific buildings, and doors are therefore character-defining features.

The regulation of door types and appearances for additions depends on its visibility. Doors that are not visible from the front façade of the historic building or the front façades of neighboring buildings benefit from greater flexibility with regards to their recommended style and appearance. Doors that are visible should be compatible with the historic commercial doors found in the District.

Recommended:

- Using simple door types that do not detract from the District or the historic building
- Using security doors of basic design and materials
- Using doors that are in keeping with the historic integrity of the District, if visible from the front façade of the historic building or the front façades of neighboring buildings

F. Additions to Existing Buildings - Commercial

Not Recommended:

- Using doors that are not in keeping with the historic integrity of the District, if visible from the front façade of the historic building or the front façades of neighboring buildings
- Using overly ornate or overly simplified door types that detract from the District or the historic building



Figure F9 -The door is not recommended because it does not have a design that is compatible with historic doors in the Stone Mountain commercial area.

F. Additions to Existing Buildings - Commercial



Figure F10 - The window on the left, although it is not original to the building, is complimentary and does not detract from the historic nature of the building.

> F.2.f – Windows and Fenestration

Windows and fenestration, or the design and character of windows and other exterior openings, are important character-defining features of a building. Improper fenestration may include the creation of new or larger openings, which disrupts a building's historic character, and the use of historically inappropriate windows.

The fenestration within the commercial character area of the Stone Mountain Historic District is typical of commercial areas of its age. Excepting display windows, which are an element of the commercial rehabilitation and maintenance section of these guidelines, the windows of the commercial character area of the Stone Mountain Historic District are rectangular, wood-frame, double-hung windows with historic light patterns, including 4/4 and 6/6 (“light patterns” refers to the number and arrangement of glass panes within a window: a “4/4” window has four panes in the top sash and four panes in the lower sash). The windows exhibit minimal ornamentation, but many are arched and capped with jack arches of the same material as the overall building of which they are a part.

F. Additions to Existing Buildings - Commercial

Recommended:

- Using wood frame windows with historically-appropriate light patterns
- Ensuring that the fenestration pattern of additions is compatible with the fenestration pattern of the historic building
- Applying storm windows that are designed so that the meeting rail (the rail where the upper and lower sashes overlap in the center of the window) of the storm window is at the same height as the meeting rail of the historic window
- Applying window surrounds or ornament (such as jack-arched masonry) that complements the ornament found on the windows of the historic building, if present and when appropriate

Not recommended:

- Using metal-framed windows
- Using snap-on mullions or muntins to give the appearance of a multi-light window
- Incorporating decorative window types, such as fanlights, Palladian windows, bay windows, or transoms, or using art glass, such as stained glass
- Incorporating display windows on additions
- Applying ornate window surrounds or other ornament for which there is no precedent on the original building

F. Additions to Existing Buildings - Commercial



Figure F11 – The roof of this addition is flat, like that of the historic building it is associated with, which is recommended.

> F.2.g – Roofs

The roof, as the highest part of a building, can be the most visually apparent place to notice improper and non-historic treatment. Not only are historically appropriate materials important to the character of the roof, unregulated contemporary elements, such as skylights, can be glaringly obvious and historically inappropriate. Furthermore, only certain roof types are appropriate for each type and style of architecture found within a historic district.

Roofs within the commercial character area of the Stone Mountain Historic District are flat or nearly flat and bordered by parapet walls. They are most commonly finished in asphalt and tar.

Recommended:

- Constructing additions with roof types that do not detract from the integrity of the buildings in the Stone Mountain Historic District
- Constructing additions with shed or flat roofs
- Designing the roof lines of additions in such a way as not to interfere with the original roof line
- Ensuring that the roof lines of additions are not visible from the front façade of the historic building
- Using roofing materials that are in keeping with the architecture of the historic building and district

F. Additions to Existing Buildings - Commercial

Not Recommended:

- Constructing roof lines that are higher than that of the historic building
- Constructing gabled, hipped, or more complex roof types
- Incorporating dormers on additions
- Applying any manner of roof ornament, such as finials or gingerbread



Figure F12 - The gabled roof of this addition to a historic commercial building interferes with the original roofline and detracts greatly from the historic character of the building. The roofing materials are also incompatible with the historic building.

F. Additions to Existing Buildings - Residential



Figure F13 -If added to the rear of the house, this roof dormer would be a recommended addition.

F.3 – Residential Buildings

> F.3.a – Location

Location is one of the most important issues in assessing whether additions are appropriate. An addition that does not respect the historic character of a building could destroy its integrity. In general, additions should not be placed on the front façade of a historic building. This placement destroys the historic character of a building, as the front façade is typically the most important.

Additions to buildings in the Stone Mountain Historic District are typically located on the back of the building with some located on the side.

Recommended:

- Locating additions at the rear of the building
- Locating additions on the side of the building and offset behind the existing front façade only when it is not possible to place behind the building
- Locating additions to limit any loss of historic character to the building
- Locating additions so that they do not dramatically change the building's overall form
- Constructing rooftop additions only visible from rear secondary streets and alleyways
- Locating new dormers lower than the primary ridge line and set in from the eave

F. Additions to Existing Buildings - Residential

Not Recommended:

- Locating additions on the front of the building
- Building an addition that increases the height of an existing building
- Constructing rooftop additions visible from the front street right-of-way of the building or from adjacent primary streets
- Locating new dormers on primary elevations



Figure F14 - This type of addition is not recommended because it is located on the front façade of the building, which obstructs the view of the historic house.

F. Additions to Existing Buildings - Residential



Figure F15 - This is a recommended rear addition because the massing and scale are both smaller than that of the historic house, making them less visible when looking at the front of the historic house. The graphic below gives examples of appropriate and inappropriate location and scale.

> F.3.b – Massing and scale

A building's **massing** is its sense of bulk, density, and weight. Its **scale** refers to the proportionate way the building relates to its surroundings. An addition can be said to be “out of scale” when it is noticeably larger or smaller than its historic neighbors.

The massing and scale of residential buildings in the Stone Mountain Historic District vary, but tend to be consistent by block.

Recommended:

- Constructing additions which are compatible with the existing building's mass
- Scaling the new addition so that it is smaller than the existing building
- Distinguishing clearly the new addition from the original building, but complementing the overall character of the original building
- Blending the roof of a new addition with the existing building's roof shape and pitch

F. Additions to Existing Buildings - Residential

Not Recommended:

- Dominating the mass and scale of the existing building
- Installing a new roof over the addition that is incompatible in shape and pitch to the existing roof
- Constructing a new addition that detracts from the overall character of the existing building
- Constructing a new addition that alters the height of the existing building

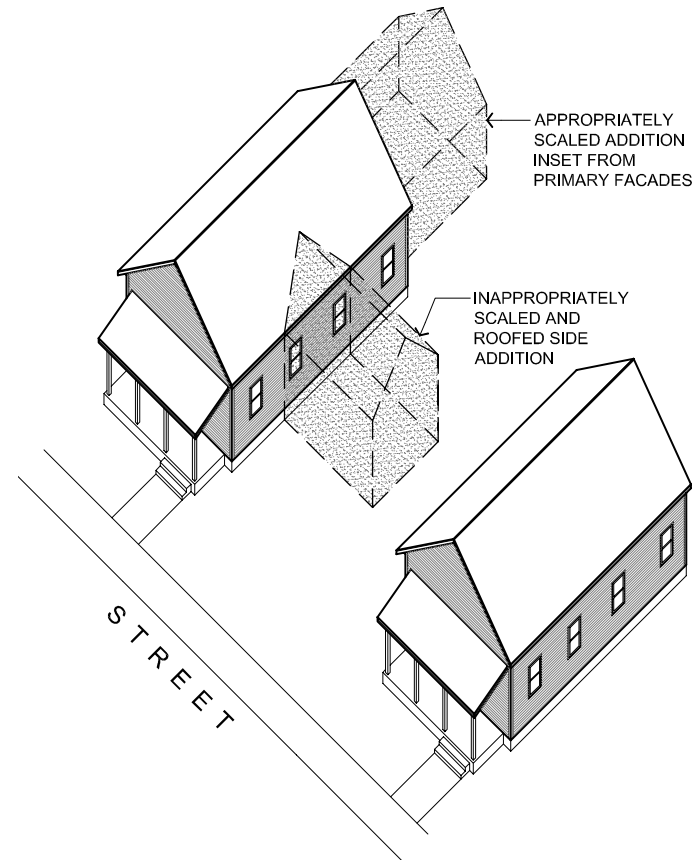

Figure F16

F. Additions to Existing Buildings - Residential



Figure F17 - This addition, made to the right, is recommended because it had been made to the side of the house and the setback allows it to be somewhat hidden from view when looking at the front of the house.



Figure F18 - This addition, to the left, is not recommended because of its setback; it has interrupted the spacing between the historic houses and although it is set back farther from the façade, it is still very visible from the front of the house.

> F.3.c – Setback

A consistency of setback, or the distance a building sits from the street, is important to a historic neighborhood. Disruption of the common setback within a historic district interferes with the visual continuity and rhythm of the historic streetscape.

The setbacks of residential buildings in the Stone Mountain Historic District vary, but tend to be consistent by block. The setbacks of buildings are generally deeper in the lot as opposed to closer to the street.

Recommended:

- Setting back a new addition on the side of the building as far as possible from the existing front façade
- Constructing a new addition with existing spacing patterns maintained between buildings along the street

Not Recommended:

- Disrupting the existing spacing pattern between buildings along the street with the setback of the addition

F. Additions to Existing Buildings - Residential

> F.3.d – Materials

Trends in prevalent building materials have changed over time. In a historic district, the use of appropriate historic materials—that is, materials that would have been used at the time of a particular building’s construction—is important. This consistency helps to assure that buildings maintain their historic integrity.

Materials that are visible from the public right-of-way, particularly those on the front façade, are the most significant, but materials in less prominent locations likewise are under the jurisdiction of the HPC, . Ordinary repair and upkeep of materials, such as painting a previously-painted surface, does not require a COA, although property owners should contact the HPC before beginning work if there is any question.

In the residential area anchored by East and West Mountain Streets, the most common exterior materials are brick, granite, and wood. Brick is commonly used not only as a wall and façade material, but for foundations as well, some of which are simple brick piers. Brick is also the most common material of historic chimneys, which are defining features of houses in this area. Granite is

a prevalent foundation material, typically used in solid wall foundations, some of which have been painted. Granite is also used decoratively in such elements as columns and entrance steps. In some houses, granite is used as the structural material for the walls which are sometimes covered with historic stucco. This combination of local materials and techniques is a unique feature of Stone Mountain buildings. Finally, wood is used most often as siding and trim-pieces, such as porch railing. Wood shingles are also common, most frequently as decoration on gables. Metal is also found within the area: examples include historic hardware and cast-iron porch railing.

Within Shermantown, brick, stone, and wood are the most common exterior materials. Brick is commonly used as a material for both foundations and chimneys. Some houses in this area, such as Ranches, are constructed with a brick veneer. Stone is also present, both in pier foundations, some of which have been reinforced and filled-in with other materials, and as solid-wall foundations. The prevalent type of stone is granite. Finally, the use of wood is a character-defining feature of these buildings. Horizontal wood siding is the most

F. Additions to Existing Buildings - Residential



Figure F19 - This addition has been constructed using recommended materials. The materials, primarily wood, are complementary to the historic house.



Figure F20 - The addition of this extra room enclosing a porch is not only not permitted in Stone Mountain, but it also uses materials that are not recommended for use on historic houses in Stone Mountain. The use of vinyl siding is not recommended.

a prevalent foundation material, typically used in solid wall foundations, some of which have been painted. Granite is also used decoratively in such elements as columns and entrance steps. In some houses, granite is used as the structural material for the walls which are sometimes covered with historic stucco. This combination of local materials and techniques is a unique feature of Stone Mountain buildings. Finally, wood is used most often as siding and trim-pieces, such as porch railing. Wood shingles are also common, most frequently as decoration on gables. Metal is also found within the area: examples include historic hardware and cast-iron porch railing.

Within Shermantown, brick, stone, and wood are the most common exterior materials. Brick is commonly used as a material for both foundations and chimneys. Some houses in this area, such as Ranches, are constructed with a brick veneer. Stone is also present, both in pier foundations, some of which have been reinforced and filled-in with other materials, and as solid-wall foundations. The prevalent type of stone is granite. Finally, the use of wood is a character-defining feature of these buildings. Horizontal wood siding is the most

F. Additions to Existing Buildings - Residential

common exterior material in the area. Wood is also used for trim.

Wood

Recommended

- Using materials that reflect, but do not attempt to duplicate, the fabric of the historic building
- Using wood or fiber cement siding

Not Recommended

- Installing vinyl or aluminum siding
- Removing or destroying extant historic materials
- Using any material that creates a false sense of age

Masonry

Recommended

- Using materials that reflect, but do not attempt to duplicate, the fabric of the historic building
- Using compatible materials such as granite or brick for foundations
- Designing additions with above-ground masonry foundations similar in height to the historic building
- Using masonry for construction of distinct elements that historically would have been constructed of masonry, such as chimneys and steps
- Using true stucco when appropriate

Not Recommended

- Using any material that creates a false sense of age
- Constructing additions on concrete slab foundations placed on-grade
- Using incompatible materials such as synthetic stucco, concrete block, and EIFS (Exterior Insulation and Finishing Systems)
- Using concrete veneer facings
- Constructing a chimney on an addition using a veneer of any material other than masonry

Metal

Recommended

- Using materials that reflect, but do not attempt to duplicate, the fabric of the historic building
- Applying metal trim and decorative elements that are compatible with the style of the historic building

Not Recommended

- Using materials that are not historically appropriate to the specific style and type of building on which work is being completed
- Using any material that creates a false sense of age
- Installing aluminum siding

F. Additions to Existing Buildings - Residential



Figure F21 – This flat wood door that does not incorporate glass would be inappropriate on an addition to a house in the Stone Mountain Historic District, since the historic doors of this district most commonly incorporate glass or paneled elements in their design. Doors on additions should be compatible with the historic door types found on the historic building to which the addition is attached.

> F.3.e – Doors

The door, as the entrance and focal point of a building, is enormously important to its historic character. Care should be taken not to install historically inappropriate doors on additions, which can create a visual dissonance and disrupt the appearance of the overall character.

Recommended:

- Installing doors and surrounding decorative features on additions that are appropriate for the style of the house
- Matching the proportions and design of screen doors and storm doors with historic doors
- Providing the greatest possible view of the main door by installing security doors with a minimal frame

Not Recommended:

- Installing doors and surrounding decorative features on additions that are inappropriate for the style of house
- Installing security or storm doors that significantly obscure the door on a primary entrance

F. Additions to Existing Buildings - Residential

> F.3.f – Windows and Fenestration

The design and character of windows and other exterior openings, are important character-defining features of a building. Improper fenestration on additions to existing structures may include the creation larger openings, which disrupts a building's historic character, and the use of historically inappropriate windows.

Recommended:

- Using materials in the windows of additions with the same visual qualities of the original windows
- Installing windows on an addition with decorative surrounds, sill, molding and lintel that are appropriate in design
- Maintaining an appropriate style and design of decorative windows, most in keeping with the style and period of the house
- Using storm windows of appropriate design that fit window dimensions and complement the window design and materials
- Maintaining a functional appearance of shutters by utilizing an appropriate shutter size for the window
- Using appropriate shutter designs and materials in keeping with the style of the house



Figure F22-The shed-roofed rear addition to this historic residential building exhibits the same 6-over-6 windows as are found on the historic building. The matching of window light patterns is just one of the elements that make this addition compatible with the historic building

F. Additions to Existing Buildings - Residential



Figure F23—The clapboard addition to this historic brick house is not compatible in many ways, including window type. The 4-over-1 windows present on the historic house are a significant character-defining feature that is diminished by the incompatible 6/6 windows on the addition.

Not Recommended:

- Using materials that are inappropriate for the style of the house
- Installing windows that reflect inappropriate design or style of the decorative surrounds, sill, moldings, and lintel
- Using storm windows with meeting rails that do not match with the meeting rails of the window
- Attaching shutters on the addition that are inappropriately sized and designed for the window
- Installing shutters that are constructed of materials inappropriate for the style of the house, such as vinyl
- Installing shutters on an addition when there are no shutters on the historic building

F. Additions to Existing Buildings - Residential

> F.3.g – Porches

Porches are a major character defining feature of historic residential buildings. Porches have traditionally served as outdoor living space, a transition space between the public and private areas of a property, and as an architectural focus of the property which is richly embellished and emphasized. As one of the most significant character-defining features of a building, porches on an addition should have similar characteristics as porches on the historic building.

Porches are typical elements on houses in the Stone Mountain Historic District. In both the area anchored by East and West Mountain Street and in Shermantown, porches vary according to the style of the house. Both full- and partial-width porches are common, with wood, masonry, or occasionally metal supports.

The appropriateness and design of a new porch should be guided by research into the location and scale of the previous porch.

Recommended:

- Constructing a new porch, if historically appropriate, that is compatible with the historic the building in scale, size, proportion, design, and materials



Figure F24 -The porch that has been added to the front of this historic house is not recommended because the materials are not compatible with the house. The railing is also not recommended because it is not complementary to the design of the house.

- Constructing additional entrances or porches on non-character-defining facades in a manner that preserves the historic character of the building
- Building railings similar in height and spacing to those used historically, while meeting current code requirements
- Basing the design of a new porch on historical, pictorial or physical evidence whenever possible

Not recommended

- Obscuring, damaging, or destroying any character-defining features

F. Additions to Existing Buildings - Residential



Figure F25 - This deck is in a recommended location, on the rear of the historic house and not visible from the front façade.

> F.3.h – Decks

Recommended:

- Constructing decks on non-character defining elevation of the property, usually on the rear of a building or in areas that are not visible from the street
- Designing and detailing decks and associated railings and steps to reflect the materials, scale, and proportions of the residence
- Aligning the deck with the height of the building's main level
- Setting the deck back from the original perimeter of the building to lessen the visual impact from the street
- Installing decks so that they are structurally self-supporting and may be removed in the future without damage to the historic building
- Constructing decks in appropriate materials such as wood or composites
- Screening with compatible foundation materials or plantings to visually tie the deck to the building

Not recommended:

- Constructing decks that project or cantilever beyond the sides of the building
- Using vinyl for decks or railings

F. Additions to Existing Buildings - Residential

> F.3.i – Roofs

The roof, as the highest part of a building, can be the most visually apparent place to notice improper and non-historic changes. Not only are historically appropriate materials important to the character of the roof, unregulated contemporary elements, such as skylights, can be glaringly obvious and historically inappropriate. Furthermore, only certain roof types are appropriate for each type and style of architecture found within a historic district.

A variety of roof types and shapes are found in the Stone Mountain Historic District, including gabled, hipped, shed, and pyramidal. The primary roofing material is asphalt shingle, though several houses have sheet metal roofing.

This subsection deals with roofs on additions. For guidelines specific to roofs on existing structures, refer to Section E.2.g on Page 87.

Recommended:

- Constructing additions with roof types which do not detract from the integrity of the buildings in the Stone Mountain Historic District
- Designing the roof lines of additions in such a way as not to interfere with the original roof line
- Ensuring that the roof lines of additions are not visible from the front façade of the historic building
- Using roofing materials that are in keeping with those of the historic building and district
- Installing additions in a manner that does not damage or visually obscure historic building fabric
- Installing new gutters and downspouts where they have not existed historically if the gutters and downspouts will prevent damage to other building features such as masonry walls and trim
- Selecting gutter and downspout styles, materials, and layouts that are appropriate to the character of the building and minimize the visual impact to the historic building
- Placing modern rooftop elements, such as mechanical units, ducts, solar panels, antennae, satellite dishes, and vents out of view from the street level or from adjacent buildings
- Incorporating new roof elements such as vents and chimneys that are visually and physically compatible with the overall design of the historic building
- Installing low-profile skylights that are not visible from the right of way

F. Additions to Existing Buildings - Residential



Figure F26 -The rear addition is out of scale with the original house in front. Its roof line is higher than that of the original building, which significantly alters the house's integrity.

Not recommended:

- Constructing additions with roof lines that are higher than that of the historic building
- Constructing additions with roof types more complex than the historic building
- Placing skylights on a primary elevation, visible from the right of way
- Inserting “bubble”-style skylights

G. Guidelines for New Construction

G.1 – The Compatibility Principle

When considering new construction (also referred to as ‘infill’) in a historic district, compatibility is important to ensure that the historic character of the district is maintained and that historic resources are not compromised. In the City of Stone Mountain, as in other locally designated historic districts, design for new and infill construction should be based on a **Compatibility Principle**.

New construction should be compatible with historic, contributing buildings on the block face, with the block face being defined as those buildings that share the same side of the street and are located between intersecting streets. Only historic buildings on either side of the new construction should be considered as part of the compatibility process.

If no historic, contributing buildings exist on either side of the new construction or on the block face, then the design for new construction should be based on historic buildings in the area that would be seen from the property.

The **Compatibility Principle** generally states that **all new construction should be no bigger than**

the biggest and no smaller than the smallest in the area of comparison. This principle can be applied to massing, scale, setback, height, roofline and window patterns of new buildings. Compatibility for new construction can also be applied when considering the orientation of buildings to the street and the general design of a building in relation to historic buildings.

If new outbuildings or ancillary structures are considered, these too should follow the principle; they should be compared not only to the principal building, but also to historic buildings that surround the new construction. Although it is important to create compatibility between new construction and historic buildings, new construction should not attempt to look historic. New buildings should not be mistaken for historic but should be complementary and draw on the visual qualities of historic structures around them.

The Stone Mountain HPC uses this **Compatibility Principle** when considering all new construction, be it in a residential or commercial area: the building and design elements of new construction should be no bigger than the biggest historic example and no smaller than the smallest historic example on the block face.

G. Guidelines for New Construction - Commercial

G.2 – Commercial Buildings

> G.2.a – Massing and Scale

A building's massing is its sense of bulk, density, and weight. Its scale refers to the proportionate way the building relates to the buildings and landscaping around it. A building that is improperly massed for a historic district can appear too large or too heavy when compared to the buildings around it. A building is "out of scale" when it is noticeably larger or smaller than its historic neighbors.

Recommended:

- Following the Compatibility Principle
- Patterning new structures after historic building forms to approximate historic building mass, roof pitch, foundation/floor-to-ceiling heights, and bay divisions
- Patterning residential buildings that will be used for commercial purposes to approximate the historic building mass, roof pitch, foundation/floor-to-ceiling heights, and bay divisions of surrounding residential examples

Not Recommended:

- Attempting to replicate historic commercial



Figure G1 - These new commercial buildings are of a recommended massing and scale. They mimic the massing and scale of historic commercial buildings like those in Stone Mountain.



Figure G2 - This new commercial building does not have a recommended massing or scale and would not be compatible for new construction in Stone Mountain. Historic commercial buildings in Stone Mountain are of two stories or less, so new construction that is three stories or more would not be recommended.

G. Guidelines for New Construction - Commercial

> G.2.b – Setback

A consistency of setback, or the distance a building sits from the street, is important to an historic neighborhood. Disruption of the common setback within a historic district interferes with the visual continuity and rhythm of the historic streetscape.

Most historic commercial buildings in the City of Stone Mountain have no setback. The only separation between the building and the street is a sidewalk. Commercial buildings that were constructed later do not follow the same setback pattern as the historic commercial buildings on the central block of Main Street; these buildings tend to be set farther back from the street and often have some kind of parking in front of the building.

Recommended:

- Following the Compatibility Principle in terms of setback

Not Recommended:

- Siting a building at a distance that does not correspond to the historic buildings on the block face

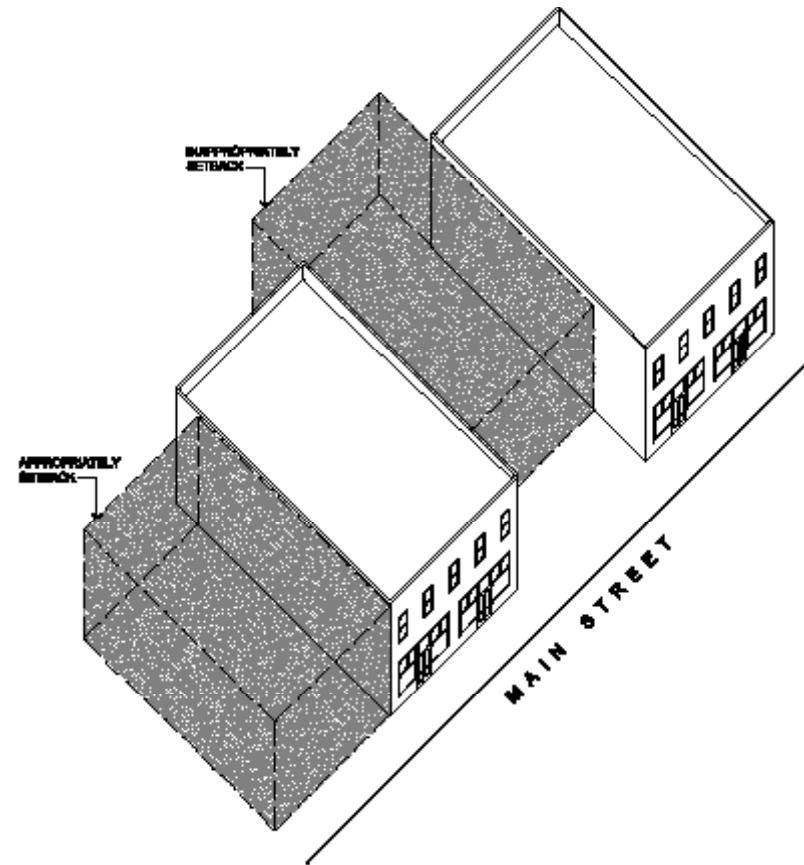

Figure G3 – This diagram shows the recommended not recommended setback for new commercial buildings that would be built between existing historic commercial buildings. This is also the recommended setback for any new construction that would be built to replace existing, non-historic commercial buildings.

G. Guidelines for New Construction - Commercial



Figure G4 - This new commercial building has a recommended design that is compatible with historic buildings on the surrounding block face. The building can be differentiated from historic commercial buildings by its use of slightly more contemporary materials and less ornate details than those of a historic commercial building, but the materials and design used do not detract from the historic character area in which it was built.



Figure G5- The general design of these new commercial buildings is not recommended because the design is not compatible with the historic buildings nearby.

> G.2.c – General Design

The general design of historic commercial buildings in the City of Stone Mountain is the one or two-part commercial block style, constructed of wood, brick, granite or other natural stone. There are commercial buildings of later construction that are made of metal; these buildings do not follow the general design of the historic commercial buildings found on the central block of Main Street.

Recommended:

- Following the Compatibility Principle in terms of general design
- Designing new commercial buildings that can be clearly differentiated from the design of historic commercial buildings according to the Secretary of the Interior's Standards

Not Recommended:

- Creating a design that does not complement the general design of existing historic commercial structures

G. Guidelines for New Construction - Commercial

> G.2.d – Storefront Design

Storefronts are the most important defining feature of most historic commercial buildings. Historically, storefronts were designed to maximize display area, increase light and attract customers using elements such as windows, doors, transoms, and other architectural detailing.

The storefronts in Stone Mountain tend to have large, display windows. Historically the doors on the central block of Main Street would have been recessed to allow for additional display space and draw the customer to the store.

Recommended:

- Following the Compatibility Principle in terms of storefront design
- Following the established solid-to-void ratio of historic buildings on the block face
- Creating a storefront that is similar in size and configuration to historic buildings on the block face

Not Recommended:

- Using window and door openings that exceed the dimensions of similar historic examples on the block face
- Attempting to look historic in storefront design



Figure G6 - The storefront design of these new commercial buildings is recommended because it has large display windows and doors with wooden frames and large panes of glass, similar to historic storefronts.

G. Guidelines for New Construction - Commercial



Figure G7 – The materials used in this new construction are recommended because they are similar and compatible to materials used in historic buildings in Stone Mountain.



Figure G8 – The materials used on this new commercial building are not recommended because they are not compatible with materials used in historic buildings in Stone Mountain.

> G.2.e – Materials

Materials are the things of which buildings are made. The prevailing trends in building material selection have changed over time. In an historic district, the use of appropriate historic materials—that is, materials that would have been used at the time of a particular building’s construction—is important. This consistency assures that buildings and districts maintain their historic integrity.

The traditional building materials used in the construction of commercial buildings in the City of Stone Mountain are wood, granite, brick, and other natural stone.

Recommended:

- Following the Compatibility Principle in terms of material
- Using building materials that were used historically

Not Recommended:

- Using vinyl or aluminum siding or External Insulation and Finish Systems (EIFS) or other materials not found on historic materials on the block fact in the construction of new buildings

G. Guidelines for New Construction - Commercial

> G.2.f – Doors

The door, as the entrance and focal point of a building, is important to its historic character. Historically, doors were often specifically designed for specific buildings, and doors are therefore character-defining features.

The typical door found on historic commercial buildings in the City of Stone Mountain would have been constructed of wood and glass. The door would have been recessed with display windows on either side of the door. Some doors on later, historic buildings were flush with the front façade of the building. For new construction, the Compatibility Principle will determine which model to follow.

Recommended:

- Following the Compatibility Principle in terms of doors
- Using clear glass for doors
- Having doors on new construction that are of the same proportion as doors on historic commercial buildings on the block face
- Using building symmetry and historic buildings on the block face to suggest door location

Not Recommended:

- Creating a false sense of history when installing doors on a new building
- Using unfinished aluminum framing for doors
- Using tinted glass in doors
- Positioning doors on the front façade so they do not correspond with historic examples on the block face



Figure G9 – The doors used in this new commercial building are compatible with doors that would be found on historic commercial buildings in Stone Mountain and are recommended.



Figure G10 – The doors used in this new commercial building are not compatible with the doors that might be found on historic commercial buildings.

G. Guidelines for New Construction - Commercial



Figure G11 – These windows are compatible with windows that are found on historic commercial buildings and are therefore of a recommended design.



Figure G12 – The windows of this new commercial building have metal frames and numerous panes of glass that span almost the entire height of the building. This is not compatible with windows found on historic buildings in Stone Mountain and is not recommended.

> G.2.g – Windows and Fenestration

The design and character of windows are important character-defining features of a building. Windows on commercial buildings in the District are typical of commercial areas of similar age with large display windows on either side of a central door. On buildings with a second story, upper windows are usually double-hung with a 4-over-4 light pattern. Historic windows on commercial buildings are typically wood frame with little or no ornament.

Recommended:

- Following the Compatibility Principle in terms of windows and fenestration
- Using clear glass for windows
- Using window proportions found in historic examples on the block face
- Using traditional divisions of a row of transom windows when historic examples exist on the block
- Repeating the height of historic bulkheads

Not Recommended:

- Creating a false sense of history when installing windows on new buildings
- Using unfinished aluminum framing on windows
- Using tinted glass in a window
- Introducing transom windows when there are no historic examples on the block face

G. Guidelines for New Construction - Commercial

> G.2.h – Roofs

The roof, as the highest part of a building, can be the most visually apparent place to notice improper and non-historic changes. Not only are historically appropriate materials important to the character of the roof, unregulated contemporary elements, such as skylights, can be glaringly obvious and historically inappropriate. Furthermore, only certain roof types are appropriate for each type and style of architecture found within a historic district.

Roofs on commercial buildings in the City of Stone Mountain are primarily flat with built-up or tar and gravel roofs.

Recommended:

- Following the Compatibility Principle in terms of roof pitch, visibility, and materials

Not Recommended:

- Using roofing materials that are not used on historic buildings on the block face
- Having a roof pitch greater or less than that found on historic buildings on the block face



Figure G13 – The roofs of these new commercial buildings are recommended because they are flat, which is compatible with the historic commercial buildings found in Stone Mountain.



Figure G14 – The roof of this new commercial building is not of a recommended design because it has a pitch that is not compatible with historic buildings that would be found in Stone Mountain.

G. Guidelines for New Construction - Commercial

> G.2.i – Outbuildings

Outbuildings, or buildings adjacent to a historic commercial building, should have appropriately historic forms, placement, and materials. Large, historically inappropriate outbuildings, like detached multiple-car garages, rarely have historic precedent, bring attention to themselves, and can overshadow the historic character of the neighborhood. Most commercial buildings in the City of Stone Mountain do not have outbuildings or ancillary structures. Where outbuildings or ancillary structures exist, they are located at the rear of the building, where they are not visible.

Recommended:

- Following the Compatibility Principle in terms of outbuildings/ancillary structures
- Locating outbuildings/ancillary structures at the rear of the main structure
- Constructing an outbuilding/ancillary structure that has a similar type and style to the historic buildings on the block face and the building with which it is associated
- Constructing an outbuilding that is smaller in scale and massing than the main building

Not Recommended:

- Locating an outbuilding or ancillary structure anywhere but the rear of the main building
- Constructing an outbuilding or ancillary structure that is of a different type or style than the main building and historic examples on the block face
- Using materials such as aluminum or vinyl to construct an outbuilding or ancillary structure
- Constructing an outbuilding or ancillary structure that is larger in scale and massing than the main building

G. Guidelines for New Construction - Commercial

> G.2.j – Driveways and Parking

Recommended:

- Creating as few curb cuts as possible when establishing driveways and parking for new commercial buildings
- Installing driveways so that they cause the least damage to historic paving and curbing materials
- Installing driveways that lead to parking in the rear of a new commercial building whenever possible
- Attempting to maintain historic parking patterns when establishing parking for new commercial buildings (i.e., having one row of parking spaces in the front of the building and relegating additional parking to another location, possibly behind the building)
- Establishing planting islands in large parking lots that must be located at the front or side of new commercial buildings
- Creating a parking lot that provides parking for several businesses in a location that allows new commercial buildings to observe the zero lot line for setback

Not Recommended:

- Creating multiple curb cuts for a driveway or parking
- Creating large parking lots at the front of new commercial buildings
- Creating large parking lots that have no planting islands

G. Guidelines for New Construction - Commercial

> G.2.k – Outdoor Lighting

Recommended:

- Installing lighting that is compatible with lighting on historic commercial buildings and the new commercial building
- Installing lighting that does not attempt to look historic
- Locating lighting where it will cause the least distraction to pedestrians and passers-by (i.e., so that the light is directed towards the building)

Not Recommended:

- Installing lighting that creates a false sense of history
- Installing lighting that is not compatible with the size or design of the building

> G.2.l – Accessibility

Recommended:

- Providing accessibility for all persons
- Installing accessibility ramps at the side of new commercial buildings and screening them from view
- Creating an entryway that is level and allows access through the front door

Not Recommended:

- Installing accessibility ramps on the front façade of a new commercial building

G. Guidelines for New Construction – Residential

G.3 – Residential Buildings

> G.3.a – Massing and Scale

A building’s **massing** is its sense of bulk, density, and weight. Its **scale** refers to the proportionate way the building relates to the buildings and landscaping around it. A new building that is improperly massed for an historic district can appear too large or too heavy when compared to the buildings around it. A building can be said to be “out of scale” when it is noticeably larger or smaller than its historic neighbors.

The massing and scale of residential buildings in the Stone Mountain Historic District vary, but tend to be consistent by block.

Recommended:

- Following the Compatibility Principle in terms of massing
- Constructing a building similar in shape to that of the buildings along the block face
- Constructing a building with compatible roof shapes and pitches to existing roofs on buildings along the block face

Not Recommended:

- Constructing a building with a roof significantly different in shape and pitch than roofs on existing buildings located along the block face
- Constructing a building with a significantly different shape to the buildings located along the block face



Figure G15 – This one-and-a-half story new house is appropriate in massing and scale for its block. It does not overwhelm the neighboring houses, but also does not stand out as too small for the block.



Figure G16 – The massing and scale of this new house is not compatible with the massing and scale of the historic house it is next to. Most historic houses in Stone Mountain are less than two stories tall.

G. Guidelines for New Construction – Residential

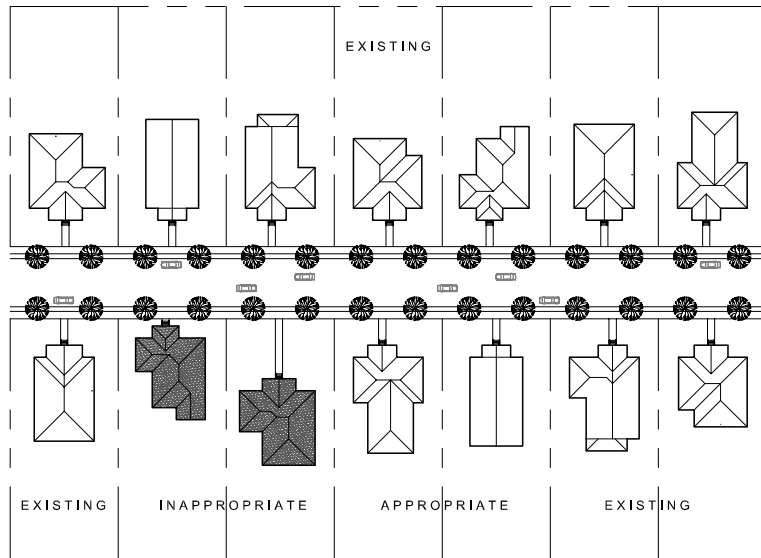

Figure G17 – Appropriate and inappropriate front setbacks for new construction.

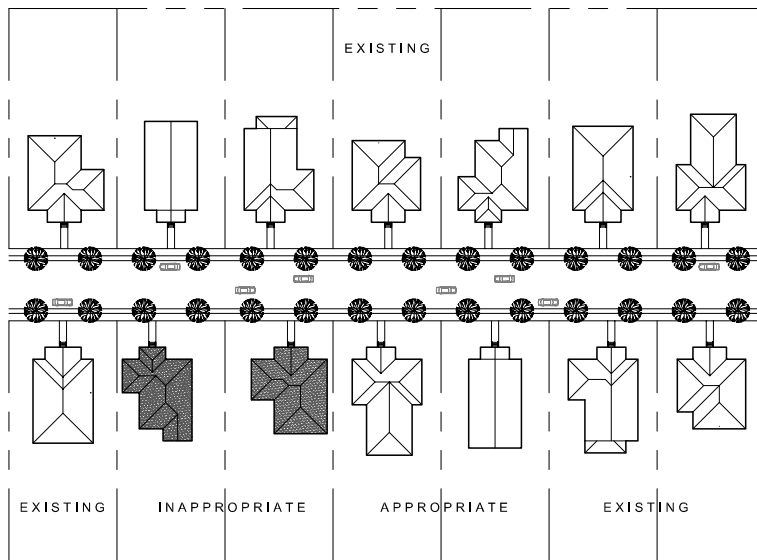

Figure G18 – Appropriate and inappropriate side setbacks for new construction.

> G.3.b – Setback

A consistency of **setback**, or the distance a building sits from the street, is important to an historic neighborhood. Disruption of the common setback within a historic district interferes with the visual continuity and rhythm of the historic streetscape.

The setbacks of residential buildings in the Stone Mountain Historic District vary, but tend to be consistent by block. The setbacks of buildings are generally deeper in the lot as opposed to closer to the street.

Recommended:

- Following the Compatibility Principle in terms of setback
- Maintaining the setback rhythm along the block face

Not Recommended:

- Disrupting the setback rhythm along the block face

G. Guidelines for New Construction – Residential

> G.3.c – Materials

Trends in prevalent building materials have changed over time. In a historic district, the use of appropriate historic materials—that is, materials that would have been used at the time of a particular building’s construction—is important.

This consistency helps to assure that buildings and districts maintain their historic integrity. Only exterior materials are regulated by the HPC. Materials that are able to be viewed from the public right-of-way, and particularly on the front façade, are the most significant. Materials in less prominent locations remain under the jurisdiction of the HPC but are assessed with greater flexibility.

Within the Stone Mountain Historic District’s residential character areas, there are many materials that reinforce the historic character of the areas. The high-style residential area anchored by East and West Mountain Streets most commonly uses as exterior materials brick, granite, and wood. Brick is commonly used not only as a wall and façade material, but for foundations as well, some of which are simply brick piers.

Brick is also the most common material of historic chimneys, which are defining features

of houses in this area. Granite is a very prevalent foundation material, and is usually used in solid wall foundations, some of which have been painted. Granite is also used decoratively in such elements as columns and entrance steps, and is found as the structural material for the walls of some houses: these walls are sometimes covered with historic stucco, a technique which represents usage of local materials and techniques and is a unique feature of Stone Mountain buildings.

Finally, wood is found most often as siding and trim, such as porch railing, but is also present as shingles, most often found as decorative elements of gables. Metal is also found within the area: examples include historic hardware and cast-iron porch railing.

In Shermantown, common exterior materials are brick, stone, and wood. Brick is commonly used as a foundation material, and also as chimney material. Some houses in this area, such as ranch houses, are constructed with a brick veneer. Stone, usually granite, is used in pier foundations, some of which have been reinforced and filled in with other materials, and as solid-wall foundations. Finally, the use of wood is a character-defining feature of

G. Guidelines for New Construction – Residential

these buildings. Horizontal wood siding is the most common exterior material in the area, while wood is also used for trim.

Wood

Recommended:

- Using wood or fiber cement siding as siding material
- Applying wood material that is compatible with the buildings on the block face on which the project is constructed
- Designing wood trim and other decorative elements as compatible with the buildings on the block face on which the project is constructed

Not Recommended:

- Using vinyl or aluminum siding
- Using synthetic stucco
- Using any material that creates a false sense of age
- Applying wood trim or decorative elements that are not compatible with the buildings on the block face on which the project is constructed
- Constructing a chimney using a veneer of wood siding or material that appears to be wood siding
- Applying wood siding or material that appears to be wood siding to an above-ground foundation

Masonry

Recommended:

- Using masonry material that respects the historic materials of the residential area in which the project is constructed
- Designing new construction with above-ground foundations of masonry that are of similar height to those on the block face on which the project is constructed
- Using materials that are distinguishable from but compatible with historic materials of the block face on which the project is constructed
- Using masonry for construction of distinct elements that historically would have been constructed with masonry, such as chimneys and steps.
- Using true stucco, when appropriate

Not Recommended

- Using concrete slab foundations placed on-grade
- Using oversized brick or exposed concrete block
- Using any material that creates a false sense of age
- Using EIFS (Exterior Insulation and Finishing Systems)
- Constructing a chimney using a veneer of any material that is not masonry

G. Guidelines for New Construction – Residential

Metal

Recommended

- Using metal materials that respect the historic materials of the residential area in which the project is constructed
- Using materials that are distinguishable from but compatible with historic materials of the block face on which the project is constructed
- Applying metal trim and ornamental decorative elements that are appropriate for new construction and compatible with historic materials of the block face on which the project is constructed

Not Recommended

- Using any material that creates a false sense of age
- Applying metal trim or decorative elements, such as railings or finials, that are not compatible with the buildings on the block face on which the project is constructed
- Using aluminum siding



Figure G19 –The inappropriate use of siding veneer on chimneys is a common inappropriate use of materials in historic districts. While siding on the house itself may be appropriate, historic chimneys in Stone Mountain are constructed of masonry.

G. Guidelines for New Construction – Residential



Figure G20 – This historic house exhibits a historic wood door with a single fixed light. When constructing new houses in Stone Mountain, one should follow the Compatibility Principle for character-defining architectural detail such as doors by observing what historic details are common on the block face.

> G.3.d – Doors

The door, as the entrance and focal point of a building, is enormously important to its historic character. Care should be taken not to construct doors that are inappropriate, creating a visual dissonance, disrupting the appearance of the overall character of the house.

Recommended:

- Installing doors and surrounding decorative features on new housing that are appropriate for the style of the house
- Following the Compatibility Principle in terms of the materials of decorative features
- Providing the greatest possible view of the main door by installing security doors with a minimal frame

Not Recommended:

- Installing doors and surrounding decorative features on new housing that are inconsistent with the Compatibility Principle

G. Guidelines for New Construction – Residential

> G.3.e – Windows

The design and character of windows and other exterior openings are important character-defining features of a building. Incompatible fenestration may include the creation of new or larger openings, which disrupts a building's character, and the use of inappropriate windows.

Recommended:

- Using materials in the windows of new with the same visual qualities of nearby historic houses
- Installing windows that reflect an appropriate design and style of decorative surrounds, sill, moldings, and lintel
- Maintaining an appropriate style and design of decorative windows most in keeping with the Compatibility Principle
- Using storm windows of appropriate design that fit window dimensions and complement the window design and materials
- Maintaining a functional appearance of shutters by utilizing an appropriate shutter size for the window
- Using appropriate shutter designs and materials in keeping with Compatibility Principle



Figure G21 – This new house in Midtown Atlanta exhibits a 6-over-1 window pattern consistent with the other homes on the block. It's a good example of a recommended approach for windows on new construction in a historic neighborhood.

G. Guidelines for New Construction – Residential



Figure G22 - The windows used in this new house are not compatible with the windows of historic houses that surround it. The windows are made with a reflective glass, they are set in metal frames and the windows are made of single panes of large glass. None of these elements is compatible with windows found on historic houses in Stone Mountain, therefore this style of window is not recommended for use on new homes.

Not Recommended:

- Installing windows on new housing that are not appropriate for the material, or design using the Compatibility Principle
- Installing windows that reflect inappropriate design or style of the decorative surrounds, sill, moldings, and lintel
- Using storm windows with meeting rails that do not correspond with the meeting rails of the window
- Attaching shutters on the new house that are inappropriately sized and designed for the window
- Installing shutters that are constructed of materials inappropriate for the style of the house, such as vinyl
- Installing security or storm doors that significantly obscure the door on a primary entrance

G. Guidelines for New Construction – Residential

> G.3.f – Porches

Porches are a major character defining feature of historic buildings. Porches have traditionally served as outdoor living space, a transition space between the public and private areas of a property, and as an architectural focus of the property, which is often richly embellished and emphasized. As one of the most significant character defining features of a building, the preservation of historic porches is imperative to buildings within historic districts.

Porches are typical elements on houses in the Stone Mountain Historic District. In both the high-style residential area anchored by East and West Mountain Street and in Shermantown, porches vary according to the style of the house. Both full- and partial-width porches are common, with wood, masonry, or occasionally metal supports

Recommended:

- Following the Compatibility Principle in terms of porches
- Incorporating porches into the design of new buildings where they are common character-defining features
- Designing porches compatible with the form, scale materials and detailing of those on surrounding buildings



Figure G23 - This new house in Midtown Atlanta exhibits a full-length porch on the front façade. As the full-length porch is a character-defining feature of the houses in Midtown Atlanta, this is an appropriate new porch for the neighborhood and block face.

Not recommended:

- Incorporating porch elements and ornament not sympathetic to the typical location of ornament on homes on the blockface and to the new structure in design, scale, and materials

G. Guidelines for New Construction – Residential

> G.3.g – Decks

Decks are not considered a historic feature and thus should not be added to the building with a method that conveys a false sense of history. Decks should not overwhelm the original building and should not be visible from the public right-of-way.

Recommended:

- Incorporating a deck at the rear of a building or in areas that are not visible from the street
- Designing and detailing decks and associated railings and steps to reflect the materials, scale, and proportions of the residence
- Aligning the deck with the height of the building's main level
- Setting the deck back from the perimeter of the building to lessen the visual impact from the street
- Constructing decks in appropriate materials such as wood or composites
- Screening with compatible foundation materials or plantings to visually tie the deck to the building

Not recommended:

- Constructing a deck on the front façade or a façade visible from the public right-of-way
- Constructing decks that project or cantilever beyond the sides of the building
- Using vinyl for decks or railings

> G.3.h – Roofs

The roof, as the highest part of a building, can be the most visually apparent place to notice improper and non-historic changes. Not only are historically appropriate materials important to the character of the roof, unregulated contemporary elements, such as skylights, can be glaringly obvious and historically inappropriate. Furthermore, only certain roof types are appropriate for each type and style of architecture found within a historic district.

A variety of roof types and shapes are found in the Stone Mountain Historic District, including gabled, hipped, shed, and pyramidal. The primary roofing material is asphalt shingle, though several houses have sheet metal roofing. Chimneys are typically of masonry, either brick or stone.

G. Guidelines for New Construction – Residential

Recommended:

- Following the Compatibility Principle in terms of roofs
- Considering the precedent set by adjacent buildings when designing rooflines for new construction
- Designing roofs of new buildings to relate to those of neighboring historic buildings in pitch, size, scale, complexity, and material
- Using roof materials on new buildings resembling those used historically
- Covering new roofs in composite shingles
- Constructing chimneys with masonry

Not Recommended:

- Constructing a building with roof shape, pitch, scale, and complexity significantly different from roofs on existing buildings along the block face
- Using roofing materials incompatible with those used historically on existing buildings along the block face
- Constructing “floating” chimneys (chimneys that do not rest on the ground, but instead are cantilevered out from the side of the building)
- Covering chimneys with siding or materials other than masonry



Figure G24 – While flat roofs may be appropriate in the Stone Mountain commercial character area, they are not in the residential character areas, where the Compatibility Principle would necessitate that gabled or hipped roofs traditional to Stone Mountain’s historic houses are most appropriate.

G. Guidelines for New Construction – Residential

> G.3.i – Appurtenances

Appurtenances are like a property’s accessories. Examples include utilities, handicapped accessibility elements, and signage. Historically inappropriate appurtenances, such as a TV satellite dish, can disrupt a neighborhood’s historic character if not placed as inconspicuously as possible.

General Recommendations

- Following the Compatibility Principle in terms of appurtenances
- Installing playsets and recreational equipment at the rear or side of the house, out of view of the public right-of-way
- Selecting window boxes and planters compatible in size, scale, style, or materials with examples on existing houses on the block face, and that do not detract from the historically-appropriate character of the new construction
- Installing house-affixed mailboxes compatible with existing examples on the block face, and that do not detract from the historically-appropriate character of the new construction

Utilities and Equipment

Recommended:

- Placing telephone, electrical, and television wires at the rear of the property or underground where possible
- Mounting meter boxes low on a side or rear wall of the residence
- Placing rooftop television antennae at the rear of the building out of view of the public right-of-way
- Installing air conditioning/heating units (including window units) on a side, rear or secondary wall of the residence
- Placing cables and wires, plumbing, heating/air conditioning units, television antennae, meter boxes, solar panels, and other utilities in locations with minimal impact on the streetscape

Not recommended:

- Placing cables and wires, plumbing, heating/air conditioning units, television antennae, meter boxes, solar panels, and other utilities where they visually dominate or damage the building
- Locating utilities, equipment and similar items on the front façade or any wall visible from the public right-of-way

G. Guidelines for New Construction – Residential

Service Areas

Recommended:

- Locating service areas for trash and recycling containers, firewood, and maintenance equipment at the rear of the property whenever possible
- Screening service areas from view, using an appropriate fence, hedge, or enclosure

Not recommended:

- Placing service areas visible from the right-of-way

Accessibility

Recommended:

- Locating ramps on a side or rear entrance whenever possible
- Constructing ramps compatible with the scale and style of the building
- Using appropriate landscape elements to screen ramps or other features related to accessibility
- Incorporating details that complement but do not match exactly the original railings and balustrades of the building
- Constructing ramps with materials that are compatible with the historic district, when possible

Not recommended:

- Constructing ramps on the front entrance of the building



Figure G25 – Accessibility ramps should be located on the side or rear of the building and screened from view of the public right-of way

G. Guidelines for New Construction – Residential

> G.3.j – Outbuildings

Outbuildings, or buildings adjacent to a house, should have appropriately historic forms and placement. Large, historically inappropriate outbuildings, like detached multiple-car garages, rarely have historic precedent, bring attention to themselves, and can detract from the historic character of the neighborhood.

Recommended:

- Designing garages and accessory structures that are similar in character to historic examples in the neighborhood
- Constructing accessory structures that are unobtrusive and do not compete visually with the primary building
- Constructing accessory structures that remain subordinate in terms of mass, size, and height to the primary building
- Locating accessory structures at the rear of the residence or to the side, set back substantially from the primary building

Not recommended:

- Constructing a garage that dominates the street scene and is not subordinate to the primary building
- Introducing a prefabricated accessory building incompatible in size, scale, form, materials, proportion, and details with historic accessory structures in the neighborhood
- Constructing outbuildings from aluminum, plastic, or vinyl

H. Community Landmark Buildings

While the Stone Mountain Historic District is composed generally of properties with either residential or commercial character, there are also multiple properties that cannot be characterized by either of these categories within the District. These properties are unique: not only do they possess distinctive architectural qualities, they also hold special historic and social significance to Stone Mountain. Because of their extraordinary significance to the community as a whole and to the integrity and appearance of the Stone Mountain Historic District, alterations to these properties should be considered independently from the general guidelines for the Stone Mountain Historic District.



Figure H1 - First Baptist Church

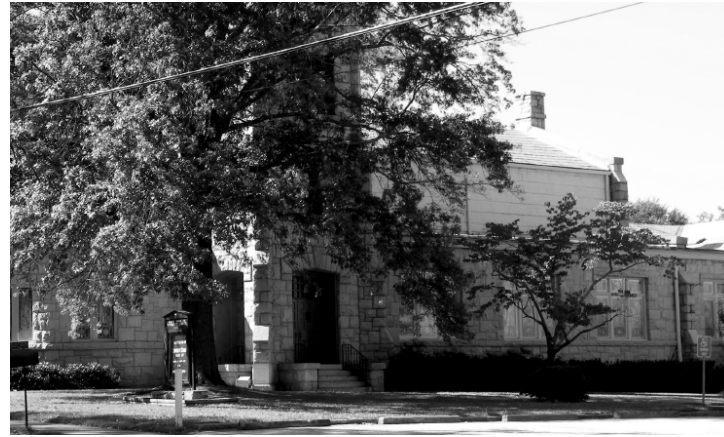

Figure H2 - Stone Mountain United Methodist Church



Figure H3 - Bethsaida Baptist Church

H. Community Landmark Buildings



Figure H4 - Georgia Railroad Depot/City Hall

Rehabilitations and additions to these buildings should be compatible solely with the resource itself, as opposed to also considering any surrounding properties or characteristics. The majority of these resources also retain exceptional integrity, and the appropriateness of alterations should be determined on a case-by-case basis. Physically, these properties are often the focal points of an area within the District. Inappropriate alteration to these resources could have a detrimental effect on the surrounding area. For example, if an inappropriate addition were placed alongside the Stone Mountain Depot, the majority of Main Street as well as parts of the residential areas would suffer from the visual incompatibility of the addition, which would be visible from all of these areas. Owners of community landmark buildings should contact the HPC for advice and discussion before planning any alteration to a special property within the Stone Mountain Historic District.



Figure H5 - Rock Gym/Stone Mountain Recreation Center

H. Community Landmark Buildings

Community Landmark Buildings within the Stone Mountain Historic District include:

- First Baptist Church
- Stone Mountain United Methodist Church
- Bethsaida Baptist Church
- Georgia Railroad Depot/ City Hall
- Rock Gym/ Stone Mountain Recreation Center
- Andrew Johnson House/ Stone Mountain Hotel/ Stillwell House
- Saint Paul's A.M.E. Church
- Trolley Station/ ART Station



Figure H7 - Saint Paul's A.M.E. Church



Figure H6 - Andrew Johnson House/Stone Mountain Hotel/Stillwell House



Figure H8 - Trolley Station/ART Station

I. Design Guidelines for Residential Landscapes

I.1 – Introduction

The historic character of any neighborhood is not solely determined by the design and composition of the contributing structures found therein. Indeed, the presence of site features, both environmental and man-made elements, contribute to the appeal and integrity of historic districts. Elements such as driveways, sidewalks, retaining walls, fences, accessory structures and even vegetation do, through their design and placement add to the personality of the residential areas in Stone Mountain’s historic district. Mature trees, shrubs and architectural features create a landscape that offers a variety of interest to pedestrians and creates a pedestrian-friendly landscape.

For these reasons, the following guidelines apply to properties experiencing rehabilitation as well as new construction and are designed to maintain the historic appearance and character of residential areas and residential buildings. Because landscapes and streetscapes contribute to the sense of place that defines a historic property, property owners are encouraged to preserve existing

landscape features and to use complementing styles, materials, plants and features when restoring landscapes or making improvements. These guidelines are applicable to areas that are visible from the street - the front yard, side yards which are exposed to the street and back yard elements that are visible from the public right of way.

Property owners should consider the following concepts of landscape design:

Scale - consider the mature size of plant materials before installation on the property. Determine that the mature size reflects the correct proportion to the lot, the building and the neighborhood.

Unity - all parts of the landscape “fit” in relation to the property, the neighborhood and the building.

Balance - may be achieved with either symmetrical or asymmetrical design but should create a sense of equilibrium.

Hierarchy - the consideration of how plant materials and hardscape elements relate to each other in size, shape, and texture will aid creating a plan that provides for a transition from public to private space.

1. Design Guidelines for Residential Landscapes

1.2 – Driveways and Parking

Driveways in the residential area anchored by East and West Mountain streets are generally located on the side of the lot and lead directly to the parking area, which could either be a garage or parking pad or area designated for parking. In Shermantown, driveways are located to the side of the lot or as a designated space in the front, parallel to the street.

Recommended:

- Placing driveways in a location that leads directly from the street to the parking area
- Minimizing the width of the driveway while providing appropriate room for vehicles (12 feet typically is an appropriate driveway width)
- Locating parking areas in the rear or side of the property
- Locating parking pad, carport or garage in the rear of side of the property and detached from the main structure
- Sharing a single driveway should be considered
- Planting landscape shrubs and trees as buffer, to shield view of parking from the street
- Preserving historic topography whenever possible

Not Recommended:

- Parking in front yard
- Parking on street
- Changing the topography of the lot
- Leveling or terracing a previous hillside lot

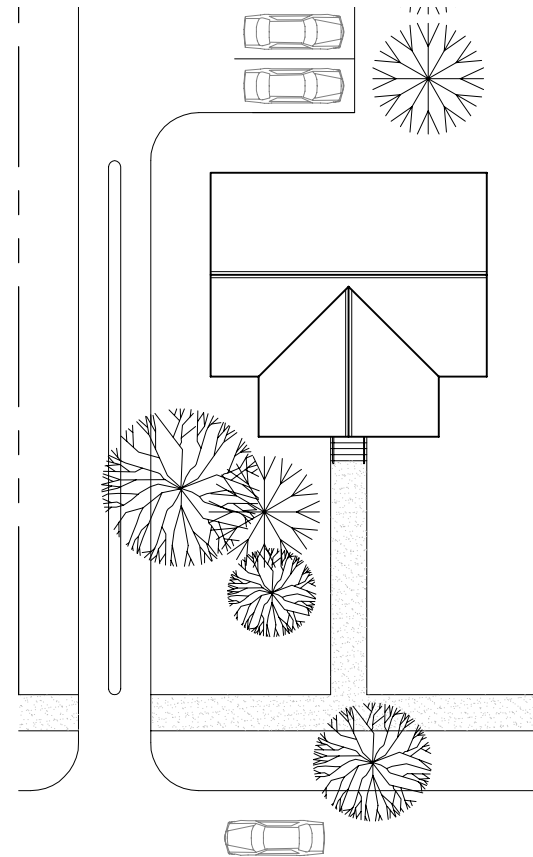

Figure 11 - Appropriate driveway

I. Design Guidelines for Residential Landscapes

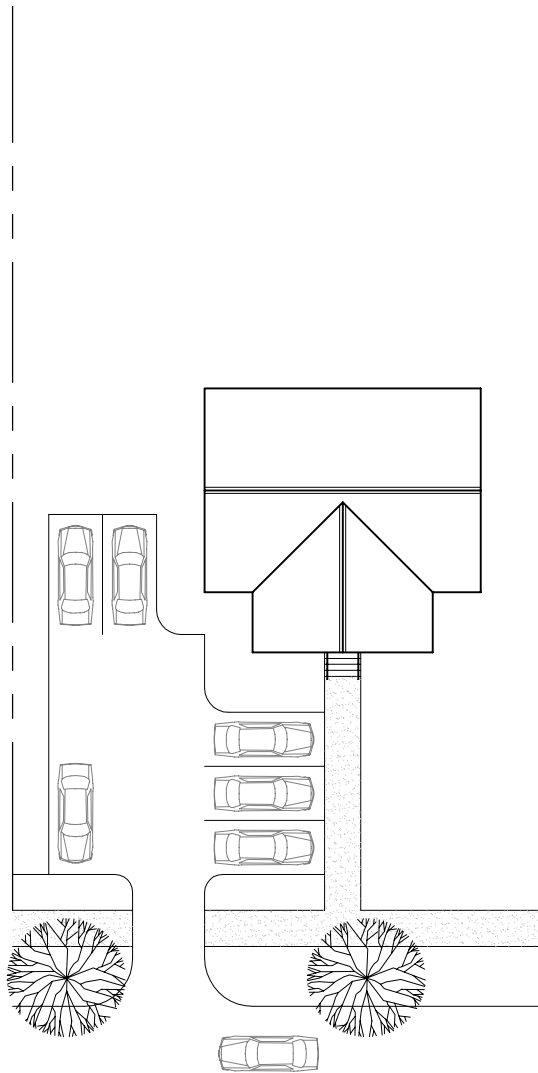

Figure I2 - Inappropriate driveway

I.3 – Entrance Walks

The residential area anchored by the East and West Mountain streets typically have walks that run from the street to the front entrance, in a straight line manner, constructed of brick or stone. Shermantown residences have frequently utilized gravel in addition to brick and stone and generally are a less formal approach to the residence.

Recommended:

- Preserving of existing materials for entrance walkways, if applicable
- Using material for restoration, repair or additions of the same type used elsewhere on the property or compatible property, as appropriate and match in material, color, texture and scoring, where applicable

Not Recommended:

- Using curved patterns for entrance walks

I. Design Guidelines for Residential Landscapes

I.4 – Outdoor Lighting

Outdoor lighting in Stone Mountain residential areas is minimal and usually limited to illumination of entrances located on building near front entrance. In areas with high style residences, additional lighting typically would be found at the street entrance to the lot.

Recommended:

- Minimizing exterior lighting as historically very few fixtures were used
- Adding accent lighting of key features of the landscape design, and providing safety lighting in a subtle manner
- Using exterior lighting fixtures appropriate in design, style and placement in landscape to the architectural elements of the property

Not Recommended:

- Using “floodlighting” visible from street
- Directing exterior lighting towards the street, the sky or a neighboring property

I.5 – Fences and Gates

Fences play a number of roles; they can define property boundaries, create private space, and add to the security and decoration of a site. While they are multi-functional, fences are not highly prevalent features in the front yards of contributing properties in Stone Mountain, and thus they must be given great consideration in terms of their impact on the character of the neighborhood before they are demolished, repaired or new ones are constructed.

When designing a fence for properties in the historic district, the factors to consider are height, location, materials and design. Height is important because it is vital that a fence not obstruct the view of the building from the street, nor interrupt the streetscape. Location also determines how a fence affects the site in question as it can create a visual impediment to the structure it surrounds. Materials and design are important because modern materials and designs are often improper in a historic district. Chain link and modern privacy fences are inappropriate and detract from the historic character of the neighborhood.

I. Design Guidelines for Residential Landscapes

Recommended

- Maintaining and preserving historic fences
- Repairing historic fences with like materials
- Keeping front-yard fences low enough (not more than four feet) to not obstruct the view of the house
- Decreasing the height of any fence that surrounds the property as it approaches the street the house faces
- Constructing new fences out of wood, cast iron or wrought iron using a vertical picket pattern, but only if the fence is characteristic of the neighborhood
- Spacing pickets so that the space between the pickets is not less than the width of an individual picket
- Constructing gates in a design and fashion similar to the fence to which it is attached
- Installing fencing that complements the design and style of the house
- Using hedges in lieu of traditional fencing when appropriate to mark property boundaries and create private space
- Using shrubs and plantings to screen or obscure chain-link fencing

Not Recommended:

- Placing rear yard fences any closer to the front façade than approximately half the distance between the front and rear façades
- Using chains or chain link for gates across driveways or walkways
- Using only gates or solitary fence sections as landscape features

I. Design Guidelines for Residential Landscapes

I.6 – Retaining Walls

In areas where the street grade is substantially lower than the grade of house lots, retaining walls provide decorative transitions from the public right-of-way to the private spaces of the yard and porch. Because of the terrain, many of the properties within Stone Mountain’s historic district have retaining walls of some sort to define the property boundary and create a level lawn. Almost all of the retaining walls around contributing properties are constructed of masonry, usually stone, brick or some combination.

We Recommend:

- Preserving and maintaining historic retaining walls
- Repairing retaining walls with like materials in a workman-like manner
- Repairing and replacing only those portions of retaining walls that need it
- Constructing new retaining walls that incorporate historic designs and materials common to the contributing structures in the area

Not Recommended

- Removing a historic wall unless it is so greatly deteriorated that it becomes a threat to the property or is deemed to be beyond repair by a qualified contractor or engineer
- Covering retaining walls in paint or stucco
- Using freestanding or “dry laid” walls
- Using retaining wall and fence combinations which obscure the view of houses from the public right of way

I. Design Guidelines for Residential Landscapes

I.7 – Landscape Structures

Like the main house on any property, ancillary or additional buildings such as gazebos, storage building, sheds, fountains and other structures can affect the character of the property and those properties in the immediate area. As such, they should be given the same due attention as primary structures. Secondary structures and landscape features should be appropriate to their setting.

Recommended:

- Maintaining and preserving historic landscape and garden structures where present
- Designing new structures compatible with the property's main building in terms of style and materials
- Placing any new gazebo, pergola, or other structure in the rear yard

Not Recommended:

- Installing garden ornamentation that detracts from the historic appearance of the house or that dominates the landscape because of size, placement, or number
- Placing water features (fountains, reflecting pools, or ponds) in front yards unless there is evidence suggesting the presence of such features historically

I.8 – Vegetation

Vegetation is often one of the overlooked features that contribute to the character of any historic district. In Stone Mountain, the pattern of landscaping demonstrates the history of the town. Large, mature trees dominate the landscape recalling an era when trees were planted to provide shade from the hot sun. Additionally, lawns and the design of shrub and flower plantings create a pedestrian-friendly atmosphere, and can often recall earlier periods in history. For these reasons, the preservation of vegetation and landscape design is encouraged by the HPC.

While the HPC does not regulate plantings and landscape designs, the following suggestions are made to assist owners in maintaining landscapes in the historic district to preserve the visible character of the area. The local County Extension Office can be of assistance in selecting appropriate plants and good gardening practices. Additionally, a list of suggested tree varieties and planting sizes is included in the appendix on Page 206.

I. Design Guidelines for Residential Landscapes

> I.8.a – Trees

Recommended:

- Preserving mature trees unless they pose an imminent danger to the public safety, or pose a risk of spreading disease
- Replanting any tree which is removed with a new tree of a similar species and variety
- Removing and grinding of any stump and backfilling the hole when a tree is removed and cannot be replaced due to extenuating circumstances

Not Recommended

- Clear-cutting existing trees or stands of trees in the historic district for construction projects even with the intent to replant
- Planting a tree of any type or specimen not native to piedmont region of Georgia

> I.8.b – Lawns and Gardens

Recommended:

- Using permeable surfaces as much as possible to aid with drainage
- Placing foundation plants an appropriate distance from the foundation
- Using shrubbery and other plant materials to screen unsightly elements such as air conditioning units and chain link fencing which are visible from the public right of way
- Using screening plants of a species, size, and number sufficient to provide the desired coverage the year round
- Using native plants in lieu of exotics

Not recommended:

- Planting invasive species
- Covering lots with concrete or other non-permeable surfaces

J. Streetscapes

J.1 – Commercial Streetscapes

Historically appropriate streetscapes are a fundamental element of historic character. Historically, streets were a unifying focal point of communities, serving as play areas, business areas, and areas of interaction. Streetscapes were often carefully designed to be a “show place” of sorts, as they were the most public area of a community. The streetscapes should reflect the District’s historic character with elements such as furnishings, landscaping, sidewalks and lighting, which all contribute to historically-appropriate streetscapes.



Figure J1 - Streetscapes were often carefully designed to be a “show place” of sorts, as they were the most public area of a community

J. Streetscapes

> J.1.a – Sidewalks (materials)

Recommended:

- Maintaining the materials used in historic construction (i.e. granite curbing and brick pavers) to create consistency
- Maintaining historic materials, scoring patterns, paving and all other aspects of construction when repairing or replacing sidewalks
- Repairing rather than replacing historic sidewalks or sidewalk materials
- Repairing historic sidewalks with in-kind materials (those materials that closely resemble the historic in consistency, composition and material)

Not Recommended:

- Replacing rather than repairing historic sidewalk materials
- Replacing historic materials with non-historic materials when no replacement it needed (replacement for purely cosmetic purposes)

> J.1.b – Sidewalks (usage)

Recommended:

- Maintaining sidewalks as a pedestrian right-of-way
- Keeping sidewalks free of obstructions
- Locating outdoor seating, trash receptacles, and moveable objects so that they are at the edge of pedestrian right-of ways (i.e. against building walls or near the edge of the sidewalk)

Not Recommended:

- Locating outdoor seating, trash receptacles, and moveable objects in the pedestrian right-of-way



Figure J2 - The arrangement of furniture, trash cans, lighting and other outdoor furnishings should be located to allow the sidewalk to remain a pedestrian thoroughfare.

J. Streetscapes

> J.1.c – Curbing

Recommended:

- Retaining historic, granite curbing
- Avoiding removal, coverage or obstruction of historic curbing
- Using granite when installing new curbing
- Repairing rather than replacing historic curbing
- Replacing historic curbing with in-kind materials if replacement is deemed necessary
- Avoiding curb cuts

Not Recommended:

- Replacing historic curbing when replacement is not necessary
- Cutting the curb materials



Figure J3 - The granite curbing used on sidewalks is a historic element that should be maintained. Brick pavers are also recommended materials for use on sidewalks.



Figure J4 - This design is not recommended because historic materials have not been used and new curb cuts have been made.

J. Streetscapes

> J.1.d – Street Lighting

Recommended:

- Preserving historic street lighting
- Making new street lighting compatible with historic street lighting (please see Compatibility Principle)
- Avoiding a false sense of history when installing new street lighting that is compatible with historic street lighting
- Making lighting attached to the exterior of a building compatible in style (please see Compatibility Principle on Page 119)
- Installing lighting on the exterior of a building that does not detract from the building façade
- Installing lighting on the exterior of a building that is in scale with the building
- Installing lighting on the exterior of a building that does not mask architectural details
- Installing lighting that is compatible with the period and style of the building
- Installing lighting in a location where it will not cause distractions or obstructions to pedestrians or passers-by

Not Recommended:

- Replacing historic street lighting with new lighting when there are no problems with the historic lighting
- Installing lighting in a style that pre-dates the historic building to which it is associated
- Installing lighting on the exterior of a building that masks architectural details
- Installing lighting on the exterior of a building that is out of scale with the building
- Installing lighting on the exterior of a building that detracts from the building façade
- Installing lighting that causes distractions or obstructions to pedestrians or passers-by



Figure J5 - The street lighting installed in the commercial area has historic design elements, but does not attempt to look historic. The lighting is also not too large in scale when compared to the buildings and other street furnishings around it.

J. Streetscapes

> J.1.e – Street Furniture

Recommended:

- Using street furniture that is compatible with existing, historic furniture
- Keeping street furniture out of the pedestrian rights-of-way
- Installing street furniture that is compatible with street furniture installed by the City (i.e. wood and metal benches)
- Installing trash receptacles that are compatible with trash receptacles installed by the City (i.e. round, metal frame cans)
- Locating commercial trash receptacles behind the building
- Screening commercial trash receptacles that are not located behind the building



Figure J6 - This bench has historic design elements and it is made of recommended materials.

Not Recommended:

- Using street furniture that is not compatible with existing, historic furniture
- Obstructing pedestrian right-of-ways with street furniture
- Installing street furniture that is not compatible with street furniture installed by the City (i.e. plastic)
- Installing trash receptacles that are not compatible with those installed by the City
- Locating commercial trash receptacles in the front of a building if the trash receptacle is not screened from view

J. Streetscapes

J.2 – Residential Streetscapes

The streetscapes of Stone Mountain can be divided into several character areas, but there are a number of consistent elements. Curbing is granite, asphalt, and cement. Concrete sidewalks are present in some areas (most of the residential area anchored by East and West Mountain streets) but not in others (most of Shermantown). Street lighting is usually mounted on telephone poles. Signage is externally lit in order to maintain a sense of historic character. Refer to Section K for more complete guidelines on signage.

Recommended:

- Retaining historic sidewalks, when present
- Repairing and preserving damaged granite curbing; constructing new curbing out of granite
- Retaining existing street lighting, where possible; constructing new street lighting that is visually compatible with the old
- Erecting signage that is externally-lit and at an appropriate scale to the adjacent properties
- Placing street furnishings that are visually compatible with adjacent historic features while not appearing to be artifacts

Not Recommended

- Destroying historic sidewalks and curbing
- Repairing granite curbing with incompatible materials
- Constructing new curbing out of a material other than granite
- Erecting internally-lit signage
- Placing street furniture that overwhelms the historic character of the district
- Placing street furniture permanently



Figure J7 - The curbing in residential areas is of various materials, including granite. When these historic curb materials exist, they should be maintained.

K. Design Guidelines for Signage

K.1 – General Considerations

Signage can be both a significant contributing historic resource and a detrimental intrusion within a historic district. Historically appropriate signage enhances the historic character of a district and particularly, its streetscapes. Maintenance of the historic character of signage helps to reinforce the overall character of historic districts.

Signage within the City of Stone Mountain is present on properties with both commercial and residential character. The character of the sign should reflect and be compatible with the type and style of building it is associated with. Signs associated with commercial buildings with residential character are primarily free standing, while the signs associated with commercial buildings within the primary commercial area are either on the front façade, on an awning or in the form of post-and-arm signs that extend from the front façade.

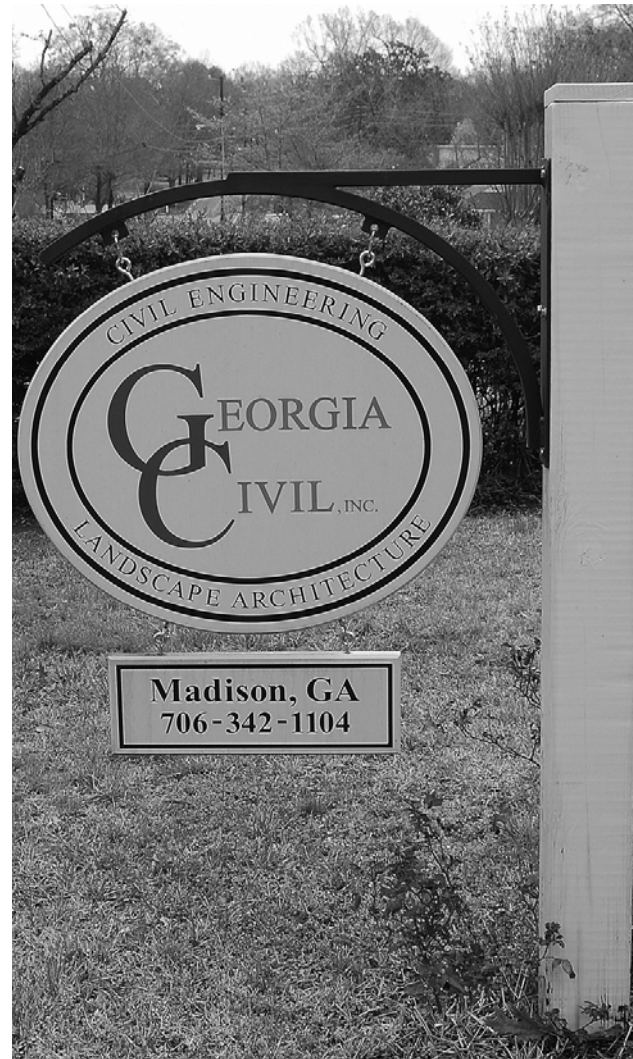

Figure K1 – This type of sign is recommended for a commercial property with residential character because it is small in scale and the lighting, which is low to the ground and masked by vegetation, is compatible with the building.

K. Design Guidelines for Signage

Recommended:

- Keeping the signage as simple as possible
- Keeping the signage in context with the building it is associated with
- Making the sign compatible with the building it is associated with
- Keeping signs in scale with the building they are associated with
- Affixing signs so that they do not obstruct the visual character or architectural details of the building
- Making signs of materials that are compatible with the historic building
- Placing signs in a location that they would have historically been placed
- Making signs of a style that is compatible with the period of construction for the historic building
- Making signs of a size permissible by the Stone Mountain Sign Ordinance
- Having three types of signs (see specific guidelines later in this section) to promote less signage clutter and create less opportunity for the obstruction of historic, architectural details
- Using sign lighting that is front-lit or directly lit with a scooped, arm or “crook-neck” light mounted above the sign
- Having free-standing post-and-arm signs for commercial buildings with residential character

Not Recommended:

- Installing signs that pre-date or post-date the building with which they are associated in type and style
- Installing signs that are out of scale with the building which they are associated with (i.e., that do not follow the Stone Mountain Sign Ordinance)
- Installing signs so that they obstruct historic, architectural features
- Installing signs in a location where they would not have been historically placed
- Installing more than three permanent signs
- Using internally light signs or awnings
- Having animated or electronic signs
- Installing flat signs on the façades of commercial buildings with residential character

K. Design Guidelines for Signage

K.2 – Primary Signs

Primary signs are the largest and most dominant sign associated with a building. They are the largest in size and are placed in the most prominent location. The primary sign also receives the most lighting, generally being placed on the primary or front façade of the building.

Recommended:

- Having primary signs with three dimensional writing which allow the characters and logos to be visible during day and night
- Having primary signs that have only the business name, logo or business type
- Having only one primary sign that is in the form of a hanging “blade” sign, a flush mounted sign or a dimensional hanging sign
- Retaining historic signs for use as a primary sign
- Having a free-standing sign as the primary sign for a commercial building with residential character
- Retaining signage that has been added to the building over time and has now gained historic significance of its own



Figure K2 –This is an example of a recommended primary sign in the blade sign design. It has three dimensional writing and only the business name.

Not Recommended:

- Having a primary sign that has more than the business name, logo or type
- Having more than one primary sign
- Removing a historic sign or removing a historic mural
- Having a primary sign on the façade of a commercial building with residential character

K. Design Guidelines for Signage



Figure K3 –This is also an example of a recommended secondary sign because it is smaller than the primary sign that is associated with the building.

K.3 – Secondary Signs

Secondary signs are generally a second, smaller version of the primary sign. They also provide additional information about the business, such as the type of business. The secondary sign can also provide the name of the business, like the primary sign only smaller in size.

Recommended:

- Having a secondary sign that is smaller in size and secondary in nature to the primary sign
- Having a secondary sign that tells the name or type of business
- Having a secondary sign located on an awning or in storefront windows

Not Recommended:

- Having a secondary sign that is larger than the primary sign
- Having an internally-lit secondary sign

K. Design Guidelines for Signage

K.4 – Subordinate Signs

Subordinate signs are those signs that are not related to the name or type of business, but they relate to business operations. Subordinate signs are intended for pedestrians to see, so they are smaller and usually located on a door or window. Types of subordinate signs include an open/closed sign, hours of operation, types of credit cards accepted or a menu posting board.

Recommended:

- Having subordinate signs that have small type and can be viewed by pedestrians or store patrons
- Having multiple subordinate signs that do not exceed three square feet in total dimension
- Having subordinate signs located in store windows

Not Recommended:

- Having subordinate signs anywhere but in the store windows
- Having subordinate signs occupy more than three square feet in total dimension

For further rules and regulations on signs in the City of Stone Mountain, please see Chapter 23 in the Stone Mountain Code of Ordinances.

L. Demolition or Relocation of Existing Structures

L.1 – Maintenance

Maintenance is paramount in the treatment of historic structures. Without proper maintenance, problems that begin as minor, easily-corrected issues can quickly manifest into costly and time-consuming structural emergencies. A COA is not required for the completion of ordinary maintenance on a building within the District. Routine maintenance is work that does not change the design, materials or exterior appearance of a building. (refer to Section 5-38-6 of the Stone Mountain Historic Preservation Ordinance on Page 186), but it can be difficult for the average property owner to determine what constitutes ordinary maintenance.

Property owners within the Stone Mountain Historic District should contact the HPC for professional advice before beginning any exterior work. Just a few minutes of discussion can avoid time-consuming meetings, assessments, and possibly even penalties that could result from the completion of exterior work without a COA

Recommended:

- Verifying the applicability of a COA before beginning any exterior work
- Maintaining, in a timely and proactive manner, contributing properties within the District
- Keeping aware of “weak spots,” such as wood gingerbread trim or roof joints, on a building and establishing a routine inspection schedule for these areas
- Comprehending a building and the differing maintenance needs inherent to some materials, ornament, systems and construction elements; for example, special cleaning techniques are involved in the proper cleaning of historic brick and stone
- Cleaning with the gentlest methods possible
- Performing maintenance in such a way that it retains as much historic material as is possible

Not recommended:

- Undertaking work before verifying the applicability of a COA to the proposed work
- Failing to routinely inspect and properly maintain a contributing building within the Stone Mountain Historic District
- Using unnecessarily harsh cleaning methods, such as sandblasting, which can severely damage historic materials

L. Demolition or Relocation of Existing Structures

L.2 – Demolition and Relocation

Demolition or removal of contributing buildings within a historic district can damage the district's character and integrity. Demolition creates a void in the streetscape, and can result in unintentional damage to neighboring properties.

Relocation of a historic building, either into or out of the district, has similar effects. Although it can result in the preservation of a historic building, it severely diminishes the building's historic significance and integrity. No matter how respectful of historic integrity the new construction that replaces a historic building is designed to be, it will nonetheless constitute the replacement of a contributing building with a non-contributing one. Therefore, demolition and relocation are only appropriate in very specific and narrowly defined circumstances, and both require a COA.

All properties within the Stone Mountain Historic District that are proposed for demolition or relocation should be evaluated by the HPC for independent historic and architectural significance, as well as significance to the District. No demolition or relocation will be considered without first presenting appropriate plans for the site after the proposed removal of the historic structure. The guidelines for infill and new construction within the Stone Mountain Historic District would then apply to post-removal plans for a site.

L. Demolition or Relocation of Existing Structures

L.3 – Demolition by Neglect

A prolonged lack of maintenance to a property creates a situation of demolition by neglect, wherein the failure to maintain said property is so great that it eventually results in the property's demise. Neglected, deteriorating properties constitute blight: they are hazardous to the general public, injurious to surrounding property values, and attractive to criminal activity, and if within a historic district, are detrimental to that district's integrity and character.

Within the City of Stone Mountain, the failure to uphold minimum property maintenance standards is a violation of the law, and the HPC and City enforce strict penalties aimed at combating “demolition by neglect.” The HPC maintains a list of neglected properties which are, on a case-by-case basis, referred to the City for prosecution under Article II, Section 5 of the Stone Mountain Code (see Page 186), which explains minimum maintenance standards. Please refer to Section E for recommendations for the proper maintenance of contributing properties within the Stone Mountain Historic District.

L.4 – Economic Hardship

Economic hardship, as it relates to the Stone Mountain Historic District, is defined as the property owner's financial inability to maintain the property as required by the Stone Mountain Historic Preservation Ordinance. In situations of verified financial hardship, “undue economic hardship” may be granted to the applicant as relief, possibly permitting a variance in the treatment of the property in question. In order to grant undue economic hardship, the HPC must review the following:

- The name and federal income tax bracket of the owner
- Documentation of the current condition of the property
- The date of purchase or acquisition of the property, and the party from whom it was acquired, as well as the amount paid for the property, and current uses of the building and the property
- The current assessed value of the land and improvements
- The current fair market value of the building and property as determined by a licensed appraiser

L. Demolition or Relocation of Existing Structures

- All capital expenditures during the ownership of the property by the current owner
- Plans for rehabilitation and documentation of the expense

It is important to remember that Federal law has declared that historic preservation is in the public interest, and therefore, the inability of the owner to attain the “highest and best use” of his property as restricted by a historic preservation ordinance does not constitute economic hardship. Furthermore, if the economic hardship is found to be self-imposed, undue hardship may not be granted.

M. Stone Mountain Cemetery

The Stone Mountain Cemetery, established in 1855, continues to be an active place of burial and remembrance. The monuments and gravestones also provide a valuable source of information about the residents of the City of Stone Mountain; the grave markers may provide information such as gender, occupation, and lifespan.

The cemetery contains more than 1300 marked and approximately 400 unmarked graves, generally located in family plots, many of which are surrounded by wrought-iron fences or granite retaining walls. A section near the front entrance is the burial site of some 150 Confederate soldiers, with graves marked by uniform rows of markers. The eastern section of the cemetery contains the majority of identified African-Americans interred in the cemetery.

The tombstones, along with other features of the cemetery such as fences and ornaments, may be architecturally significant in their own right. Located at the northern edge of the historic district, the cemetery falls under the review authority of the HPC, in accordance with chapter 6 of the Stone Mountain City Code.

M.1 – Grave Markers

Grave markers are any object, be it a headstone, a small statue, a monument or a mausoleum, that marks the location of a grave. The grave markers in the Stone Mountain Cemetery are of various shapes, sizes and materials.

Recommended:

- Constructing gravestones, monuments and mausoleums of appropriate scale to surrounding gravestones, monuments and mausoleums
- Limiting the width of headstones and markers to three feet (*Stone Mountain Code, Chapter 6, Section 6-8 (c)*)
- Constructing gravestones, monuments and mausoleums of marble, granite or other natural stone materials (*Stone Mountain Code, Chapter 6, Section 6-8 (b)*)
- Using brick for replacement if the material is historic and already present, in which case it should be in-kind correspond to the original as closely as possible (*Stone Mountain Code, Chapter 6, Section 6-8 (d&e)*)
- Cleaning with the gentlest means possible

M. Stone Mountain Cemetery



Figure M1 - These are examples of some of the markers in the Stone Mountain Cemetery.



Figure M2 - This raised plot has been paved over in an effort to reduce maintenance, but because a proper drainage system was not established, the walls of the plot are beginning to bow and could soon fall over.

- Avoiding harsh chemical cleaners, pressure washing or sand blasting as this may cause damage to the materials
- Repairing damaged gravestones, monuments or mausoleums only in consultation with a professional conservator or masonry artist to ensure proper materials and techniques are used
- Using in-kind materials (as close to the original as possible in consistency, color and composition) for gravestone, monument or mausoleum repair
- Using crushed granite or small stones to cover over raised plots
- Constructing above-ground crypts or stone boxes with the permission of the sexton (*Stone Mountain Code, Chapter 6, Section 6-8 (e)*)
- Constructing above-ground crypts or stone boxes only when such a structure exists on the plot currently (*Stone Mountain Code, Chapter 6, Section 6-8 (e)*)

Not Recommended

- Using brick or concrete masonry unit (cinder block) material in repair when it was not used historically in construction (*Stone Mountain Code, Chapter 6, Section 6-8 (d&e)*)
- Using modern materials dissimilar in composition to the historic materials for repair

M. Stone Mountain Cemetery

- Installing metal clamps, wooden braces or any support materials that are not temporary
- Constructing crypts or mausoleums unless granted permission by the sexton, following submission of plans and specifications for approval (*Stone Mountain Code, Chapter 6, Section 6-8 (b)*)
- Constructing crypts and mausoleums not comparable in scale with existing examples
- Moving gravestones or monuments unless the grave itself is also moved
- Separating any portions of a gravestone, monument or mausoleum from the grave site, should future repairs be undertaken to maintain the integrity of the object
- Re-inscribing a marker unless it is to re-emphasize a current inscription and in such an instance it should only be performed with extreme care and by a professional
- Paving over raised plots unless a proper drainage system is established to prevent water from becoming trapped beneath the paving, causing the walls to bow
- Leaving flowers or grave decorations in disrepair
- Improper or lack of disposal of live, floral grave decorations

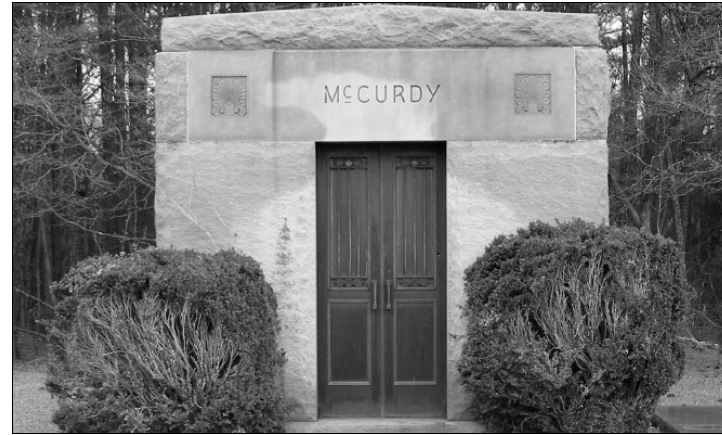

Figure M3 - This is an example of a recommended mausoleum. It is made of appropriate materials and it is not too large in scale for what is around it.

- Constructing an above-ground crypt or stone box without the permission of the sexton (*Stone Mountain Code, Chapter 6, Section 6-8 (e)*)
- Constructing an above-ground crypts or stone boxes on a plot when no such structure existed previously (*Stone Mountain Code, Chapter 6, Section 6-8 (e)*)

M. Stone Mountain Cemetery



Figure M4 - This retaining wall is made of recommended materials and is located where it will not cause serious drainage issues.

M.2 – Retaining Walls

Recommended:

- Building retaining walls of a similar material to existing walls (i.e. granite or brick)
- Designing walls in a pattern that mimics the historic pattern, but does not attempt to look historic itself
- Establishing some form of drainage system within a retaining wall where there is the potential for water to collect behind the wall

Not recommended:

- Building retaining walls of any material other than brick or granite
- Positioning retaining walls so as to trap water

M. Stone Mountain Cemetery

M.3 – Fences

Recommended:

- Erecting fences, enclosures and railings that are approved by the sexton (*Stone Mountain Code, Chapter 6, Section 6-8 (d)*)
- Erecting fences, enclosures and railings in material similar to existing fences, enclosures or railings without imitating their historic appearance
- Using wrought iron for fences and railings
- Constructing enclosures of granite or a natural stone material

Not recommended:

- Erecting fences, enclosures and railing that are not approved by the sexton



Figure M5 - This is an example of the historic fencing found in the Stone Mountain Cemetery. It should be maintained whenever possible.

M. Stone Mountain Cemetery



Figure M6 - Paths like this, which are not paved and have been left between plots, should be maintained.

M.4 – Paths and Drives

Recommended:

- Paving drives to allow general access to the cemetery
- Leaving space between enclosed plots to allow pedestrian traffic to other plots

Not recommended:

- Allowing through traffic in the cemetery (Stone Mountain Code, Chapter 6, Section 6-9 (f))
- Paving paths between plots when they were not previously paved

M. Stone Mountain Cemetery

M.5 – Plants and Vegetation

Recommended:

- Using plants and vegetation native to the area
- Trimming grass with the gentlest means possible, by hand if possible, to avoid damage to gravestones, monuments or mausoleums
- Having the plot owner maintain plants and vegetation within a plot

Not recommended:

- Locating plants and vegetation where they may obstruct a grave or cause future harm to a grave

N. Archaeological Resources

Archaeological resources are non-renewable sources of information about the past and include both artifacts (objects made or modified by humans) and features (soil stains). For thousands of years the Stone Mountain region has been a hub of human activity. The evidence of this human activity may still be present in numerous varieties of remains.

During the course of construction or gardening, prehistoric or historic artifacts may be found. These below ground resources can be analyzed in the same way that above ground resources can be analyzed, providing vital information on the history and use of the landscape in Stone Mountain.

While it is not a requirement, if the ground is disturbed, it is suggested that individuals be observant of potential archaeological resources. If an archaeological site is found, work should be halted, and the Stone Mountain HPC and the Historic Preservation Division (HPC) of the Georgia Department of Natural Resources should be notified. (Contact information for each group can be found in the appendix). The HPD web site includes basic information on archaeology.

Those individuals who will be disturbing the soil in the process of their projects should keep in mind that historic and prehistoric human burials and burial goods are protected by law. Even though there may be little left of the burial itself, the burial goods may still provide vast amounts of information about the interments. If evidence of possible burials appears, work must be halted, and the Stone Mountain HPC and the Georgia Historic Preservation Division should be contacted.

O. Appendices

O.1 – Glossary

accessory structure: a secondary structure on a property, such as a garage or shed, which is detached from the main building.

addition: extra space added to a building which alters the size and shape of the original building; the added space is usually connected to the roof or walls of a building.

ancillary: something that is subordinate or auxiliary to the main building.

appurtenance: an accessory to the building or property, such as an HVAC unit, a satellite dish or a handicap ramp.

architectural ornament: decorative details added to a building.

architrave: the molding around a door or the lowest part of an entablature above a column.

art glass: glass similar to stained glass that uses a combination of colors as well as variations of opaqueness and transparency to create an aesthetic appearance; generally used in windows

bargeboard: a board that hangs from the projecting end of a roof to hide the ends of horizontal roof timbers under the incline of a gabled roof; these boards are often decorated or carved.

bay window: a multi-part window which projects from the exterior wall of a building; typically the window is composed of three separate windows.

board and batten siding: vertical siding made of wider planks of wood whose seams/gaps are covered with smaller strips of wood.

bracket: an architectural element that projects from a wall and supports the weight of another plane that extends from the wall; typically found in the eave of a building supporting the roof.

brick bond: the pattern created by headers (the short end of a brick) and stretchers (the long side of a brick) when laying rows of bricks or other masonry to form a wall.

cornice: horizontal trim-work, like molding, at the top of a building, where the wall meets the roof.

curvilinear: a curved line rather than a straight line.

dormer: a window that projects from the slope of a roof and is topped by a small, separate roof.

eave: the edge of a roof overhanging the building wall.

entablature: in classical architecture, it separates the columns from the roofline. It has three parts from bottom to top: architrave, frieze, and cornice.

extant: that which exists.

fanlight: a semi-circular window/light above a door.

fenestration: the arrangement of openings in a building; this applies primarily to windows.

O. Appendices

finial: a decorative ornament used to accent the peak of a spire, gable, or other pinnacle on a building.

gabled roof: a roof that slopes from two sides, creating a triangular shape and the top of the end walls.

gingerbread: a form of trim that typically has scrolls, curves, and cutouts which make it seem delicate and ornate; this is typically associated with a house of the Folk Victorian or Gingerbread style from the late 19th century.

glazing: the glass portion of a window or door.

gothic revival: a revival of medieval architecture and part of the Picturesque movement; a style of architecture especially popular for churches. It was not a pure style when applied to houses in the United States and was never very popular in Georgia. These houses typically have steeply pitched and gabled roofs, elaborate bargeboards, arched window and door openings or hoods, slender porch posts with brackets, and board-and-batten siding to emphasize verticality.

hipped roof: a roof that slopes from all four sides of a building.

I-house: uncommon house type in Georgia though occasionally found in small towns of Piedmont and Upper Coastal Plains regions. This house type was built from the 1840s to the 1880s. It can be 1 or 2 stories, is one room deep and at least 2 wide with subtypes based on the floor plan (central hallway,

saddlebag, hall-parlor, et cetera). The I-house was named because of its popularity in Midwestern states beginning with the letter “I” such as Indiana.

infill: new structures built in vacant lots.

light: a pane of glass, a window, or a section of a window.

lintel: a horizontal beam above a door or window supported by the vertical framing pieces.

mansard roof: a roof that slopes twice from each of the four sides of a building; the lower slope is generally steeper than the upper slope.

massing: the overall three-dimensional shape of a building; the physical volume or shape of a building.

moldings: a horizontal wooden accent strip used to break up a surface by accenting or decorating it.

mullion: a vertical element that separates and sometimes supports windows that are set in a series or row.

muntin: a framing element within a window, window wall, or door with glass, that holds the panes/lights of glass in place.

ogee style gutters: a gutter style in which the base and back are flat while the front profile has an S-curve.

orientation: the way a building faces in relation to the street.

Palladian window: a three-part window made-up of an arched window with a narrower, rectangular window on either side.

O. Appendices

pent roof: a single-slope roof that usually joins the wall of a building above first-floor windows; also referred to as a shed roof.

pilaster: a decorative element designed to look like a column, but which is set into the façade of a building and projects only slightly from the wall, providing no support.

pier foundation: a foundation support system formed by a series of masonry columns.

Portland cement: the gray cement commonly used in modern construction and made from a limestone mixture.

preservation: the process of applying the preventative measures necessary to sustain the existing form, integrity and materials of a historic property.

reconstruction: the process of depicting the form, features and character of a non-existing site, landscape, structure, landscape or building through new construction.

repoint: the removal of existing, deteriorating mortar between masonry joints and the refilling with a new and compatible mortar; used as a form of preservation for masonry walls.

rehabilitation: the process of returning a property to a state of utility, through repair or alteration, which makes possible an efficient contemporary use while preserving those portions and features

of the property which are significant to its historic, architectural, and cultural values.

restoration: the process of accurately depicting the form, features and character of a property at a particular time by means of removing features added after that period and reconstructing features lost from that period.

sash: the frame of a window.

scale: the overall size of a building; this generally refers to how a building relates in size and massing to the buildings around it.

shed roof: a single-slope roof; see also pent roof.

sidelight: a fixed window pane/light placed on either side of a door or window opening.

sill: a horizontal beam under a window on which the vertical framing rests.

skylight: a window set into a roof.

stucco: an exterior finish composed of Portland cement, lime and sand.

transom light / transom window: a window above a door, typically rectangular in shape, made of a single pane/light or several smaller panes/lights of glass

vergeboard: a decorative board that hangs from the projecting end of a roof; see also bargeboard.

* Glossary developed from the National Park Service website and Illustrated Dictionary of Historic Architecture by Cyril M. Harris

O. Appendices

O.2 – Preservation Ordinance

ARTICLE II. HISTORIC PRESERVATION COMMISSION

Sec. 5-31. Purpose.

In support and furtherance of its findings and determination that the historical, cultural and aesthetic heritage of Stone Mountain is among its most valued and important assets and that the preservation of this heritage is essential to the promotion of the health prosperity and general welfare of the people;

In order to stimulate revitalization of the business districts and historic neighborhoods and to protect and enhance local historical and aesthetic attractions to tourists and thereby promote and stimulate business;

In order to enhance the opportunities for federal or state tax benefits under relevant provisions of federal or state law; and

In order to provide for the designation, protections, preservation and rehabilitation of historic properties and historic districts and to participate in federal or state programs to do the same;

The Mayor and Council of the City of Stone Mountain hereby declares it to be the purpose and intent of this article to establish a uniform procedure for use in providing for the protection, enhancement, perpetuation and use of places, districts, sites, buildings, structures, objects, landscape features and works of art having special historical, cultural or aesthetic interest or value, in accordance with the provisions of this article.

(Ord. of 6-7-94(1), § 1)

Sec. 5-32. Definitions.

[For the purposes of this article, the following words and phrases shall have the meanings respectively ascribed to them by this section:]

Certificate of appropriateness means a document evidencing approval by the historic commission of an application to make material change in the appearance of a designated historic property or of a property located within a designated historic district.

Designation means a decision by the governing authority of Stone Mountain to designate a property or district as a “historic property” or as a “historic district” and thereafter prohibit all material change in appearance of such property

O. Appendices

or within such district prior to the issuance of a certificate of appropriateness by the preservation commission of Stone Mountain.

Exterior architectural features means the architectural style, general design and general arrangement of the exterior of a building or other structure, including, but not limited to, the kind or texture of the building material and the type and style of all windows, doors, signs and other appurtenant architectural fixtures, features, details or elements relative to the foregoing.

Exterior environmental features means all those aspects of the landscape or the development of a site which affect the historical character of the property.

Governing authority means the Mayor and Council of the City of Stone Mountain.

Historic district means a geographically definable area designated by the governing authority as a historic district pursuant to the criteria established in this article.

Historic property means an individual building, structure, site, object or work of art including the adjacent area necessary for the proper appreciation thereof designated by the governing authority

as a historic property pursuant to the criteria established in this article.

Material change in appearance means a change that will affect either the exterior architectural or environmental features of a historic property or any building, structure, site, object, landscape feature or work of art within a historic district, such as:

- (1) A reconstruction or alteration of the size, shape or facade of a historic property, including relocation of any doors or windows or removal or alteration of any architectural features, details or elements;
- (2) Demolition or relocation of a historic structure;
- (3) Commencement or excavation for construction purposes;
- (4) A change in the location of advertising visible from the public right-of-way; or
- (5) The erection, alteration, restoration or removal of any building or other structure within a historic property or district, including walls, fences, steps and pavements, or other appurtenant features.

Person includes any natural person or corporation.

O. Appendices

Preservation commission means the City of Stone Mountain Historic Preservation Commission.

(Ord. of 6-7-94(1), § 2)

Sec. 5-33. Creation and appointment.

- (a) There is hereby created a commission whose title shall be “City of Stone Mountain Historic Preservation Commission” (hereinafter referred to as “preservation commission”). The preservation commission shall consist of no less than five (5) and no more than seven (7) members. Members of the preservation commission shall be residents of the city for at least one (1) year prior to taking office and shall be persons who have demonstrated special interest, experience or education in the preservation of historic resources, history or architecture. At least a majority of members shall be licensed architects, landscape architects, interior designers or professionals in the fields of history, architectural history, planning, archaeology or related disciplines.
- (b) The governing authority shall take action as may reasonably be required to inform city residents that an opening exists on the preservation

commission. The governing authority shall accept applications from interested individuals, review the applications and recommend a short list of potential candidates to the mayor. The mayor shall nominate individuals from the short list for confirmation by the council no later than the work session next following receipt of the short list.

- (c) The term of office for members of the preservation commission shall be three (3) years. The term of office for initial appointments shall be three years and end on January 31, 2007. Should a member of the preservation commission be unable to complete a term of office, the governing authority shall fill the remainder of the term in the same manner as appointments. Members of the preservation commission may serve until their successors are appointed.
- (d) Members of the preservation commission shall serve without compensation but may be reimbursed for reasonable expenses subject to the purchasing policies and procedures of the city.

O. Appendices

*(Ord. of 6-7-94(1), § 3; Ord. No. 01-8, Pt. I, 9-4-01;
Ord. No. 04-02, Pt. I, 5-4-04; Ord. No. 05-19, 10-4-05)*

Sec. 5-34. Powers and duties.

The preservation commission shall:

- (1) Prepare and maintain an inventory of all properties within its jurisdiction which have previously been placed in the National Register of Historic Place or the Georgia Register of Historic Places or which otherwise have the potential for designation as historic property;
- (2) Recommend to the governing authority specific places, districts, sites, buildings, structures, objects or works of art to be designated by ordinance as historic properties of historic districts;
- (3) Review applications for certificates of appropriateness, and grant or deny same in accordance with the provisions of this article and O.C.G.A. § 44-10-28;
- (4) Recommend to the governing authority that the designation of any place, district, site, building, structure, object or work of art as a historic property or as a historic district be amended, revoked or removed;
- (5) Restore or preserve any historic properties acquired by the city, with the approval of the governing authority;
- (6) Recommend to the governing authority the acquisition by the city of facade easements and conservation easements in accordance with the provisions of state and federal law;
- (7) Conduct educational programs on historic properties located within the city and on general historic preservation topics;
- (8) Make such investigations and studies of matters relating to historic preservation, including consultation with historic preservation experts or other persons, as the governing authority or the preservation commission may itself, from time to time, deem necessary or appropriate for the purpose of preserving historic resources;
- (9) Seek out local, state, federal, and private funds for historic preservation, and make recommendations to the governing authority concerning the most appropriate uses of any federal funds acquired.

O. Appendices

- (10) Submit to the Office of Historic Preservation of the Georgia Department of Natural Resources a list of designated historic properties and historic districts;
- (11) Participate in private, state and federal historic preservation programs and, with the consent of the governing authority, enter into agreements to do the same;
- (12) Review and make comments to the state office of historic preservation concerning the nomination of properties within its jurisdiction to the National Register of Historic Places or the Georgia Register of Historic Places.

(Ord. of 6-7-94(1), § 4)

Sec. 5-35. Assistance by city.

The governing authority shall provide technical and clerical assistance as the preservation commission may require and shall maintain permanent and complete records of the activities of the preservation commission.

(Ord. of 6-7-94(1), § 5)

Sec. 5-36. Bylaws.

The preservation commission shall adopt rules and procedures, such as bylaws and design guidelines, for the transaction of its business and for consideration of applications for designations and certificates of appropriateness. The preservation commission shall have the prerogative to adopt reasonable rules and standards without amendment to this article or the vote of the governing authority. The preservation commission shall provide for the time and place of regular meetings and a method for the calling of special meetings. The preservation commission will meet at least monthly unless the chair determines that insufficient business warrants holding a meeting, in which case the preservation commission shall meet the following month. A quorum shall consist of a majority of the appointed members.

The preservation commission shall elect a chair and such other officers as it deems appropriate from among its members. Officers shall serve one-year terms and shall be eligible for reelection. The preservation commission shall elect its initial officers at the first meeting following their appointment and thereafter in January of each year.

O. Appendices

(Ord. of 6-7-94(1), § 6; Ord. No. 04-02, Pt. I, 5-4-04)

Sec. 5-37. Designations.

Designations of places, districts, sites, buildings, structures, objects, or works of art or historic properties or districts shall be by ordinance adopted by the governing authority, which shall be subject to the following requirements:

(1) **Studies.** The governing authority, an historical society, neighborhood organization, property owner(s) or resident(s), may request that the preservation commission initiate studies of individual properties or districts to determine whether they meet the criteria specified in this section of designation as historic properties or historic districts. The preservation commission may also initiate such a study or studies on its own initiative based on a review of the city's historic resources. Upon determining that such recommended properties or districts meet the criteria for designation, the preservation commission may submit an ordinance for designation to the governing authority in accordance with the provisions of this section.

(2) **Reports.** The preservation commission shall prepare a report prior to submitting an ordinance for designation to the governing authority. The report shall contain, as a minimum:

- a. A physical description of the property(ies) and/or district(s) proposed for designation;
- b. A statement of the historical, cultural, architectural and/or aesthetic significance of the same;
- c. A map showing district boundaries and classification (e.g., historic, nonhistoric, intrusive and other significant categories) of individual properties therein, or showing boundaries of individual historic properties;
- d. A statement justifying district or individual property boundaries; and
- e. Representative photographs.

These reports shall be used to educate the community and to provide a permanent record of the designation.

(3) **Criteria.** The preservation commission shall consider, but not be limited to, the following criteria when considering recommendations to the governing authority for designation of historic properties or historic districts.

O. Appendices

- a. Historic properties whether they:
 1. Are of an outstanding example of a structure representative of its era;
 2. Are one of the few remaining examples of past architectural style;
 3. Are a place or structure associated with an event or persons of historic or cultural significance to the City of Stone Mountain, DeKalb County, the State of Georgia, or the nation;
 4. Are a site of natural or aesthetic interest that is continuing to contribute to the cultural or historical development and heritage of the city, county state or nation; or
 5. Are currently on or have been declared eligible by the appropriate authorities for listing on the National Register of Historic Places or Georgia Register of Historic Places.
 - b. Historic districts whether they:
 1. Have special character or special historic or aesthetic value or interest;
 2. Represent one (1) or more periods, styles or types of architecture typical of one (1) or more eras in the history of the city, county, state or nation;
 3. Cause such area, by reason of such factors, to constitute a visibly perceptible section of the city; or
 4. Are currently on or have been declared eligible by the appropriate authorities for listing on the National Register of Historic Places or Georgia Register of Historic Places.
- (4) **Notice to state.** At least thirty (30) days prior to making a recommendation on any ordinance designating a property or district as historic and at least fifteen (15) days prior to the public hearing for such designation, the preservation commission must submit a report to the Office of Historic Preservation of the Georgia Department of Natural Resources or its successor for review and comment, as required by O.C.G.A. § 44-10-26(b).
- (5) **Ordinance.** Any ordinance designating any property as historic property or any district as a historic district shall:

O. Appendices

- a. Require that the designated property or district be shown on the official zoning map of the city and be kept by the city as a public record to provide notice of such designation in addition to other notice requirements specified by this section;
- b. Describe each property to be designated, set forth the name or names of the owner or owners of the property and require that a certificate of appropriateness be obtained from the preservation commission prior to any material change in appearance of the designated property; and
- c. Include a description of the boundaries of such district, list each property located therein, set forth the name of the owner or owners of each property and require that a certificate of appropriateness be obtained from the preservation commission prior to any material change in appearance of any structure, site or work of art located within the designated historic district.

(6) **Notice and hearing.** The preservation commission and the governing authority shall hold a public hearing on any proposed

ordinance for the designation of any historic district of property. Notice of the hearing shall be published in at least three (3) issues of the principle newspaper of general circulation within the city and written notice of the hearing shall be mailed to all owners and occupants of such properties. All such notices shall be published or mailed not less than ten (10) nor more than twenty (20) days prior to the date set for the public hearing. A notice mailed to the last known owner of the property shown on the city tax records and a notice mailed to the address of the property on which residences of businesses are located to the attention of the occupant shall constitute legal notification to the owner and occupant under this article.

This published notice shall state the time, date, place and purpose of the hearing. This published notice shall also include the location or boundaries of the property or properties, the existing zoning classification and historic designation, if any, and a statement that the property could be proposed for historic designation during the proposal process.

O. Appendices

The preservation commission shall give notification of the proposal by mail to all abutting property owners as shown by the city tax records. Such notification shall be mailed not less than ten (10) nor more than twenty (20) days prior to the date set for the public hearing and shall include a description of the application and the date, time and place of the public hearing.

The commission shall cause to be erected a sign or signs giving notification of the date, time, and place of a public hearing to consider the proposed historic designation. In the case of an historic property, one (1) sign shall be placed on the property visible from a public street. In the case of an historic property, one (1) sign shall be placed on the property visible from a public street. In the case of a historic district, signs shall be placed at each point where the district boundary intersects a public street.

- (7) **Recommendations to governing authority.** A recommendation to affirm, modify or withdraw the proposed ordinance for designation shall be made by the preservation commission within

fifteen (15) days following the public hearing and shall be in the form of a resolution to the governing authority.

Following receipt of the preservation commission's recommendation, the governing authority may adopt the ordinance as proposed, may adopt the ordinance with any amendments it deems necessary, or reject the ordinance.

- (8) **Final notice.** Within thirty (30) days following a designation by the governing authority, the owners and occupants of each designated historic property, and each structure, site or work of art located within a designated historic district, shall be given written notification of such designation by the governing authority. The notice shall apprise owners and occupants of the necessity of obtaining a certificate of appropriateness prior to undertaking any material change in appearance of the historic property designated or within the historic district designated.
- (9) **Moratorium.** If an ordinance for designation is being considered, the preservation commission shall notify the city manager and no permit

O. Appendices

of any kind shall be issued for work which would constitute a material change in the appearance of a structure, site, landscape or piece of art within the designated area until the proposed ordinance is enacted or rejected by the governing authority. The preservation commission must propose an ordinance of designation to the governing authority no more than sixty (60) days after the city manager denies a building permit based on the moratorium.

(Ord. of 6-7-94(1), § 7)

Sec. 5-38. Certificate of appropriateness.

After the designation by ordinance of a historic property or of a historic district, no material change in the appearance of such historic property, or of any building, structure, site or work of art within such historic district shall be made or be permitted to be made by the owner or authorized agent unless or until the application for a certificate of appropriateness has been submitted and approved by the preservation commission.

(1) Application for certificate of appropriateness.

Owners of historic property or of property

in a historic district, or their duly authorized agents, must make application for a certificate of appropriateness on forms and according to procedures promulgated by the preservation commission for such purpose. The Georgia Department of Transportation and contractors performing work funded by the Georgia Department of Transportation are exempt from provisions of this article. Local governments are also exempt from obtaining certificates of appropriateness but shall notify the preservation commission at least forty-five (45) days prior to the beginning or undertaking of any work that would require a certificate of appropriateness, so as to allow the preservation commission an opportunity to comment.

All applications for certificates of appropriateness shall be accompanied by drawings, photographs, plans and documentation required by the preservation commission. Written authorization of the property owner shall be required if the applicant is not the owner of record.

O. Appendices

(2) **Public notice.** At least seven (7) days prior to review of an application for a certificate of appropriateness, the commission shall take such action as may reasonably be required to inform the owners of any property likely to be affected by reason of the application and shall give the applicant and such owners an opportunity to be heard. In cases where the commission deems it necessary, it may hold a public hearing concerning the application. For such public hearings, the commission shall post notice in the form of a sign in a conspicuous place on the property in question.

The preservation commission shall give the property owner or applicant an opportunity to be heard at the certificate of appropriateness hearing, as well as other parties expressing an interest in the issuance of such certificate.

The preservation commission shall approve or reject an application for a certificate of appropriateness within forty-five (45) days after the filing thereof by the owner or occupant of an historic property or building, structure, site or work of art located within a historic district. Evidence of approval shall be by certificate

of appropriateness issued by the preservation commission. Failure of the preservation commission to act within said forty-five (45) days after the filing thereof by the owner or occupant of a historic property or building, structure, site or work of art located within a historic district. Evidence of approval shall be by certificate of appropriateness issued by the preservation commission. Failure of the preservation commission to act within said forty-five (45) days shall constitute approval and no other evidence of approval shall be needed unless the owner or occupant of the property for which the certificate is requested agrees in writing to a delay. During such delay, negotiations may occur between the preservation commission and the owner or occupant to resolve any questions or issues regarding the application.

(3) **Review of applications.** When reviewing applications for certificates of appropriateness, the preservation commission shall consider, in addition to any other pertinent factors, historical and architectural value and significance; architectural style; scale;

O. Appendices

height; setback; landscaping; general design; arrangement, texture and materials of the architectural features involved and the relationship thereof to the exterior architectural style; and pertinent features of other properties in the immediate neighborhood. When considering applications, the secretary of the interior's "Standards for Historic Preservation Projects," the secretary of the interior's "Standards for Rehabilitation," and the "City of Stone Mountain Historic District Design Guidelines" shall be cited in the approval or denial of an application for a certificate of appropriateness.

(4) **Interior changes.** In its review of applications for certificates of appropriateness, the preservation commission shall not consider interior arrangements or use having no effect in exterior architectural features. The preservation commission may delegate the responsibility for determining the extent of interior change and its effect on the exterior appearance to the planning director.

- (5) **Demolition.** A decision may be made by the preservation commission approving or denying a certificate of appropriateness for the demolition of buildings, structures, sites or objects.
- (6) **Ordinary maintenance and repair.** Ordinary maintenance or repair of any exterior architectural feature in or on a historic property, that does not involve a material change in design, material, or outer appearance thereof, is excluded from review.
- (7) **Approval.** The preservation commission shall approve the application and issue a certificate of appropriateness if it finds that the proposed material change(s) in appearance would not have a substantial adverse effect in the aesthetic, historic or architectural significance and value of the historic property or the historic district. The preservation commission may approve the application as proposed, approve it with modifications, or reject the application.
- (8) **Final action.** Evidence of approval shall be by certificate of appropriateness by the preservation commission. Notice of the issuance or denial of a certificate of appropriateness

O. Appendices

shall be sent to the applicant and all other persons who have filed a written request for such notice with the preservation commission.

In the event the preservation commission rejects an application, it shall state its reasons for doing so, and shall transmit a record of such actions and reasons, in writing, to the applicant. The preservation commission may suggest alternative courses of action if it disapproves of the application submitted. The application may make modifications to the plans and may resubmit the application at any time after doing so.

In cases where the application covers a material change in the appearance of a structure, which would require the issuance of a permit of any kind, the rejection of the application for a certificate of appropriateness by the preservation commission shall be binding upon the city manager and no permit shall be issued.

All work performed pursuant to a certificate of appropriateness issued pursuant hereto shall conform to the requirements of such certificate. In the event work is performed which is

not in accordance with such certificate the preservation commission shall issue a cease and desist order and all work shall cease.

A certificate of appropriateness shall become void unless construction is commenced within twelve (12) months of the date of issuance. Certificates of appropriateness shall be issued for a period of eighteen (18) months and are not renewable.

- (9) **Records.** The preservation commission shall keep a public record of all applications for certificates of appropriateness and of all the preservation commission's proceedings in connection with such applications. Such records shall be maintained in the offices of the city.
- (10) **Appeals.** Any person adversely affected by any determination made by the preservation commission relative to the issuance or denial of a certificate of appropriateness may appeal such determination to the governing authority. Any appeal must be filed within fifteen (15) days after the issuance of the determination or, in the case of a failure of the preservation commission to act, within fifteen (15) days

O. Appendices

of the expiration of the forty-five-day period allowed for preservation commission action. The governing authority may approve, modify or reject the determination made by the commission if the governing body finds that the commission abused its discretion in reaching its decision. Appeals from decisions of the governing authority may be made to the superior court of the county. The governing authority is authorized to institute any appropriate action or proceeding in a court of competent jurisdiction to prevent any material change in appearance of a property that is designated under the provisions of section 5-37 of this article, except those changes made in compliance with the provisions of this article.

(Ord. of 6-7-94(1), § 8; Ord. No. 05-05, pt. I, 3-1-05; Ord. No. 05-18, 10-4-05; Ord. No. 06-14, pt. I, 9-5-06)

Sec. 5-39. Acquisitions.

The preservation commission may, where such action is authorized by the governing authority, enter into negotiations with the owners of historic properties within historic districts for the acquisition by gift or purchase of ownership of the

property or any interest therein. Final approval and ownership of these properties would be by the governing authority.

(Ord. of 6-7-94(1), § 9)

Sec. 5-40. Failure to maintain historic property.

Property owners of historic properties or properties within historic districts shall not allow their buildings to deteriorate by failing to provide ordinary maintenance or repair. The preservation commission shall monitor the condition of historic properties and existing buildings, structures, sites, and works of art located in historic districts to determine if they are being allowed to deteriorate by neglect.

If the preservation commission determines a failure to provide ordinary maintenance and repair, the preservation commission will notify the property owner of the property to set forth the steps which need to be taken to remedy the situation. The owner of such property shall have thirty (30) days to initiate the appropriate repairs.

In the event that efforts to correct the condition are not commenced within thirty (30) days, the owner shall be considered in violation of this article and shall be subject to fines not to exceed

O. Appendices

one thousand dollars (\$1,000.00) for each day of violation. Alternatively, at the direction of the governing authority, the preservation commission may perform such maintenance or repair as necessary to prevent deterioration by neglect. The owner of the property shall repair as is necessary to prevent deterioration by neglect. The owner of the property shall be liable for the cost of such maintenance and repair performed by the preservation commission.

(Ord. of 6-7-94(1), § 10)

Sec. 5-41. Exceptions.

Where by reason of unusual circumstances, the strict application of any provision of this article would result in exceptional practical difficulty or undue hardship upon any owner of any specific property; the preservation commission in passing upon applications shall have power to vary or modify strict adherence to said provisions or to interpret the meaning of said provision so as to relieve such difficulty or hardship; provided such variance, modification, or interpretation shall remain in harmony with the general purpose and intent of said provisions so that the architectural or historical integrity or character of the property

shall be conserved and substantial justice done. In granting variations, the preservation commission may impose such reasonable and additional stipulations and conditions as will, in its judgment, best fulfill the purpose of this article. An undue hardship shall be a situation beyond the control of the applicant, which is a problem unique to a specific property or in order to comply with this article, the person will violate another ordinance of the city. The burden of demonstrating the existence of the hardship by a preponderance of evidence shall be with the applicant.

(Ord. of 6-7-94(1), § 11)

Sec. 5-42. Application fees.

Each application for a certificate of appropriateness shall be accompanied by a fee of ten dollars (\$10.00), a copy of which will remain on file in the planning department, to partially defray the public expense in processing such application. The fee shall not be required for an application filed by the city or any nonprofit agency or organization.

(Ord. of 6-7-94(1), § 12)

Secs. 5-43--5-70. Reserved.

O. Appendices

O.3 – Cemeteries

Editor's note: This section of the appendix quotes the portion of the Stone Mountain cemetery ordinance most relevant to the city's Historic District. For the entire cemetery ordinance, please refer to the Stone Mountain Code of Ordinances.

Sec. 6-8. Rules for construction and maintenance.

- (a) All work must be approved in advance by the sexton including that done by private owners, contractors, and monument companies.
- (b) Monuments, paving, curb, wall, coping or any other edifice constructed on cemetery lots shall be made of marble, granite or other natural stone material. No brick or cinder block material shall be allowed in the construction or repair of any cemetery lot or monument. Steel reinforced concrete walls shall be allowed upon approval by the sexton.
- (c) All headstones and markers shall have proper foundations no wider than three (3) feet.
- (d) No fence, railing, or enclosure of any kind will hereafter be allowed to be erected in any part of the cemeteries unless previously approved by the sexton. The erection of vaults or tombs wholly or partly above the ground will not be allowed without special permission from the sexton. Applications for permission to build such structures must be accompanied by plans and specifications for approval.
- (e) No marble or stone enclosure or box shall be erected or built over any graves on any lot unless approved by the sexton. In cases where it is desired to duplicate those structures already on a lot, such enclosures or boxes must be supported by foundations at the center of the sides as well as at the ends. Applications for permission to build such structures must be accompanied by plans and specifications for approval.
- (f) Guy ropes may be attached to trees or posts only by special permission from the sexton, sufficient padding to be used in all cases. Planks must be laid on the sod where barrows or trucks are used to move stone.

O. Appendices

(g) No mortar or cement shall be mixed on the roadways or paths. Boards must be used in every case. No monumental work shall be delivered at the cemetery until the foundation is completed, and the contractor is ready to proceed with the work. Notice must be given at city hall before any monumental work is brought into the cemetery.

(h) No stone work shall be brought into the cemetery on weekends except by permission of the sexton.

(i) The sexton shall have the authority to enter any lot or grave site and issue stop work orders in connection with any provision of section 6.8. The sexton shall also have the authority to remove any dead or dangerous tree, shrub, vine, structure, or any object contrary to the regulations contained in section 6.8.

(Ord. No. 99-11, Pt. 1, 9-7-99)

Sec. 6-9. General rules and regulations.

(a) No signs of an advertising nature shall be permitted within the cemetery.

(b) Visitors are required to keep to the walks and roads, and are not permitted to climb upon banks, terraces, walls or monuments.

(c) No alcoholic beverages shall be permitted in the cemeteries.

(d) No person with firearms shall be permitted to enter the cemeteries except for sworn peace officers and military personnel in the conduct of a funeral ceremony.

(e) Removal of flowers following a burial shall be the responsibility of the lot owner or family of the deceased, and shall be completed within ten days of burial. Papers or decayed flowers must not be thrown on the roadways of lots, but must be removed from the grounds or placed in trash receptacles.

(f) No through traffic shall be permitted in city owned cemeteries.

(g) City owned cemeteries shall be closed to the public at dusk each day except for the holder of a valid burial permit or the holder of a license issued by the state to operate a funeral home, or with permission of the sexton.

O. Appendices

(h) It shall be unlawful for any person to block or obstruct any of the walks or driveways in city owned cemeteries.

(i) It shall be unlawful for the owner of any animal to bring such animal into any city cemetery, except for seeing eye dogs and any honorary guard utilizing horses in a funeral procession.

(Ord. No. 99-11, Pt. 1, 9-7-99)

Sec. 6-10. Penalties.

Any person guilty of a violation of this chapter shall be punished as provided in section 1-11.

(Ord. No. 99-11, Pt. 1, 9-7-99)

O.4 – Local and National Resources

City of Stone Mountain

922 Main Street

Stone Mountain, GA 30083

Phone: 770-498-8984

Fax: 770-498-8609

The official City of Stone Mountain website consists of information on the operation of the city. For more information please email or call the City Hall.

www.stonemountaincity.org

Email: info@stonemountaincity.org

Stone Mountain Historic Preservation Commission

922 Main Street

Stone Mountain, GA 30083

Phone: 770-498-8984 (City Hall)

For more information on the Design Guidelines or the COA process please contact the HPC. The Stone Mountain HPC website contains information on the administration and operation of the commission.

www.stonemountaincity.org

Email: info@stonemountaincity.org

O. Appendices

Main Street Stone Mountain

922 Main Street
Stone Mountain, GA 30083
Phone: 770-498-7334

Main Street Stone Mountain, Inc. is a private, non-profit organization devoted to the revitalization of Stone Mountain Village. They are committed to assisting residents, local businesses, and property owners in enhancing business, and promoting a healthy community where people want to live and do business.

www.stonemountainvillage.com

Stone Mountain Historic Society, Inc.

P.O. Box 71
Stone Mountain, GA 30086-0071

The Stone Mountain Historic Society, Inc. is the local group devoted to enhancing knowledge and appreciation of local historic resources.

DeKalb History Center (DHC)

Old Courthouse on the Square
101 East Court Square
Decatur, GA 30030
Phone: 404-373-1088
Fax: 404-373-8287

The DeKalb History Center is dedicated to keeping the history of DeKalb County, Georgia through preservation, education and documentation.

www.dekalbhistory.org

Historic Preservation Division, Georgia

Department of Natural Resources

34 Peachtree Street, NW
Suite 1600
Atlanta, GA 30303
Phone: 404-656-2840 (Main Number)

The Historic Preservation Division (HPD) of the Georgia Department of Natural Resources is Georgia's State Historic Preservation Office. The HPD administers a range of federal and state preservation programs for the state of Georgia.

www.gashpo.org

O. Appendices

The Georgia Trust for Historic Preservation (GTHP)

1516 Peachtree Street, NW
Atlanta, GA 30309
Phone: 404-881-9980
Fax: 404-875-2205

The Georgia Trust for Historic Preservation is the statewide nonprofit dedicated to promoting an appreciation of Georgia's diverse historic resources and providing for their protection.

www.georgiitrust.org

Email: info@georgiitrust.org

National Trust for Historic Preservation

1785 Massachusetts Ave. NW
Washington, DC 20036-2117
Phone: 202-588-6000
Fax: 202-588-6038

The National Trust for Historic Preservation (NTHP) is a nationwide preservation nonprofit dedicated to promoting an appreciation of national historic resources and providing for their protection.

www.nationaltrust.org

Email: info@nthp.org

National Park Service (NPS)

Heritage Preservation Services
1849 C Street, NW (2255)
Washington, DC 20240
Phone: 202-513-7270

The National Park Service assists in the preservation of natural and cultural resources nationwide.

There are several departments within the NPS that may prove to be helpful in maintaining your neighborhood. The following website listings are courtesy of the NPS.

www.nps.gov

Email: NPS_Hps-info.nps.gov

The Secretary of Interior's Standards for Rehabilitation

The ten standards are used as the basis for making common decisions about work that may affect the preservation of individual properties or the character defining features of a district.

www2.cr.nps.gov/tps/tax/rhb

Preservation Briefs

These Preservation Briefs created by the National Park Service provide easily understandable guides to aid in maintenance and rehabilitation of historic structures.

www2.cr.nps.gov/tps/briefs/presbhom.htm

O. Appendices

O.5 – Landscape Resources

When considering adding plants to a green space, several factors should be considered, including the plant’s cultural needs (light and water requirements), size at maturity, growth rate, and its natural susceptibility to disease and pests.

General recommendations by width of green space available:

- 10 feet or more.....Large deciduous tree
- 5 to 10 feet.....Medium deciduous tree
- Less than 5 feet.....Small deciduous tree

Recommended guidelines based on height available:

- Overhead wires present: Small trees (6-12’ tall)
- Overhead wires absent: Large/medium trees

Recommended tree species for urban environments

Large/medium deciduous trees

- Southern Sugar Maple
- White Oak
- Red Maple
- Southern Red Oak
- Silver Maple
- Darlington Oak
- American Beech
- Water oak
- White Ash
- Willow Oak
- Green Ash
- Shumard Oak
- Sycamore

Small deciduous trees

- Serviceberry
- Redbud
- American Hornbeam
- Dogwood
- Washington Hawthorn
- Fringe Tree
- Sourwood
- Hophornbeam

O. Appendices

Evergreen trees

Eastern Red Cedar

American Holly

For additional information and recommendations, contact your Dekalb County Extension Office or a landscape professional.

Certificate of Appropriateness (COA)



Permit Number: _____

Date Received: _____

Date: _____

Action Taken: _____

Date Processed: _____

Application Fee: \$10.00

Ordinary Maintenance does not require an application fee.

PROPERTY ADDRESS

Property Address or Lot Information: _____

APPLICANT INFORMATION

Applicant Name: _____ Phone Number: (____) _____

Mailing Address: _____

Fax Number: (____) _____ Email Address: _____

PROPERTY OWNER'S INFORMATION (if different from above)

Property Owner's Name: _____

Address: _____ Phone Number: (____) _____

PROJECT DESCRIPTION (please check all the apply)

Structure Alteration (visible changes to exterior or style of existing structure)

Windows Doors Porches Lighting Awning

Demolition or Relocation

Primary Building Accessory Building Site Feature Trees or Vegetation

Site Alteration

Signs Pools Fence(s) / Wall(s) Mechanical system(s) Walkways/Sidewalks

Non-Temporary site feature

Construction

New Building Additions Accessory Building

Major building restoration, rehabilitation, or remodeling

Ordinary Maintenance & Repair (A COA is not required, but the HPC requests that an application and samples be submitted to be kept on file to ensure that work performed is per the application). Ordinary maintenance is not to be a change in material or in appearance, if so a COA is required.

Re-roofing Wood repair (only a portion of Windows Doors
(shingles) siding, porch, fence, etc.) (repair) (repair)

Interior Alterations that affects exterior appearance of existing structure

Other: _____

Certificate of Appropriateness (COA)

Certificate of Appropriateness (COA)

PROJECT DESCRIPTION

Describe the current site and the proposed project in detail, including the materials and proposed finishes. Additional pages may be attached if necessary. _____

REQUIRED MATERIALS

The following materials are the minimum required by the HPC in order to have a complete application. Incomplete applications will not be reviewed by the HPC until all information is submitted.

New Building and Additions

- * stamped set of architectural elevations (all sides)
- * stamped site plan (building, fencing, paving)
- * description of project
- * landscaping plan (saved and proposed vegetation)
- * description of construction materials
- * photographs of proposed site and adjacent sites
- * stamped set of architectural floor plans
- * proposed finishes (samples)

Site Changes-fences, walls, and other site features

- * stamped set of architectural elevations (all sides)
- * site plan (building, fencing, paving, etc.)
- * description of project
- * landscaping plan (saved and proposed vegetation)
- * description of construction materials
- * photographs of existing site and adjacent sites
- * proposed finishes (samples)

Site Changes-parking, drives, and walks

- * site plan (building, paving, fencing, etc.)
- * description of construction materials
- * photographs of existing and adjacent sites
- * proposed finishes (samples)

Signs

- * architectural elevations (for signs located on the building)
- * site plan (for signs that are free standing)
- * description of project
- * description of construction materials and type of illumination

Major Restoration, Rehabilitation, or Remodeling

- * stamped set of architectural elevations (all sides)
- * stamped site plan (building, fencing, paving)
- * description of proposed changes
- * landscaping plan (saved and proposed vegetation)
- * description of construction materials
- * photographs of existing and adjacent buildings
- * stamped set of architectural floor plans
- * proposed finishes (samples)
- * documentation of earlier historic appearance (restoration only)

Minor Exterior Changes

- * description of project
- * description of construction materials
- * photographs of existing building
- * proposed finishes (samples)

Demolition

- * complete site plan showing existing location of structures
- * complete site plan showing new development
- * description of project
- * description of construction materials
- * photographs of existing site and adjacent sites
- * proposed finishes (samples)
- * landscaping plan (saved and proposed vegetation)

AUTHORIZATIONS

I HEREBY CERTIFY that I am the owner(s) of the property or that the proposed work is authorized by the owner of record and I have been authorized by the owner to make this application as his/her authorized agent. Furthermore, I certify I have read and understand the procedures and guidelines set forth in the Stone Mountain Historic District Design Guidelines.

Signature of Owner(s) Date

Signature of Applicant Date

Signature of Authorized Agent Date

Certificate of Appropriateness (COA)

PROCEDURES FOR APPLYING

Application Requirements:

All applications must be complete and include all required support materials listed on the next page to be considered for review. All materials should be in an 8 1/2"x11" format in addition to any scale format needed for detail. Incomplete applications **WILL NOT** be reviewed by the HPC or put on the Agenda for that month.

Application Deadline:

Applications are to be submitted to Stone Mountain City Hall by 12:00 noon 14 days prior to the regular scheduled HPC meeting to be placed on that month's agenda. Should this day of the month fall on a weekend or holiday, applications are due the **next** business day by 12:00 noon. The HPC meets on the third Tuesday of each month at 7:30 p.m. at Stone Mountain City Hall, unless otherwise posted outside City Hall.

Application Representation:

The **applicant** or an **authorized representative** for the applicant shall be present at the public meeting to support the application. If neither is in attendance to answer questions which may arise, the result will be **denial** of the application.

Building Permit Requirements:

All building permits must be acquired from the governing authority prior to any work commencing. Building permits will not be issued without proof of an approved COA. Work must comply with all applicable state and local codes.

Deadline for Project Completion:

A COA shall become void unless construction (foundation and framing) is commenced within **twelve (12) months** from the date of issuance. A COA is issued for a period of **eighteen (18) months** only and is not renewable.

Required Submittals:

Applicants are required to submit 8 copies of the signed application and all required material to be reviewed.

DESIGN GUIDELINES

Copies of the Design Guidelines are available at City Hall for a minimal fee. The HPC uses the Secretary of Interior's Standards and the Stone Mountain Design Guidelines to guide all decisions. Past actions of the HPC may be considered in review of a COA, but the HPC is not bound to confer the same resolution on a similar application.

IMPORTANT NOTES

Pending Approvals:

Are there any approvals pending by any other regulatory or administrative authority, which may have a bearing on the modifications or improvements which are the subject of this application? If so, specify: _____

Penalties:

Failure to apply for a certificate of appropriateness shall warrant the applicant to be fined in the same manner as provided in Section 1-11 (Code 1976, § 1-1012).

Modifications or Amendments:

If modifications or amendments become necessary, such changes must be presented to and approved by the HPC prior to beginning work on any aspect of said modification or amendment.

AUTHORIZATIONS

I HEREBY CERTIFY that I am the owner(s) of the property or that the proposed work is authorized by the owner of record and I have been authorized by the owner to make this application as his/her authorized agent.

Signature of Owner(s) Date

Signature of Applicant Date

Signature of Authorized Agent Date

Certificate of Appropriateness (COA)

PROCEDURES FOR APPLYING

Application Requirements:

All applications must be complete and include all required support materials listed on the next page to be considered for review. Applicants are required to submit 8 copies of the signed application and all required material to be reviewed. All materials should be in an 8 1/2"x11" format in addition to any scale format needed for detail. Incomplete applications **WILL NOT** be reviewed by the HPC or put on the Agenda for that month.

Pending Approvals:

If approvals are pending by other regulatory or administrative authorities, which may have bearing on the modifications or improvements which are the subject of this application, please notify the HPC upon COA application submittal.

Application Deadline:

Applications are to be submitted to Stone Mountain City Hall by 12:00 noon 14 days prior to the regular scheduled HPC meeting to be placed on that months agenda. Should this day of the month fall on a weekend or holiday, applications are due the **next** business day by 12:00 noon. The HPC meets on the third Tuesday of each month at 7:30 p.m. at Stone Mountain City Hall, unless otherwise posted outside City Hall.

Application Representation:

The **applicant** or an **authorized representative** for the applicant shall be present at the public meeting to support the application. If neither is in attendance to answer questions which may arise, the result could be **denial** of the application.

Building Permit Requirements:

All building permits must be acquired from the governing authority prior to any work commencing. Building permits will not be issued without proof of an approved COA. Work must comply with all applicable state and local codes.

Modifications or Amendments:

If modifications or amendments become necessary, such changes must be presented to and approved by the HPC prior to beginning work on any aspect of said modification or amendment.

Deadline for Project Completion:

A COA shall become void unless construction (foundation and framing) is commenced within **twelve (12) months** from the date of issuance. A COA is issued for a period of **eighteen (18) months** only and is not renewable.

Penalties:

Failure to apply for a certificate of appropriateness shall warrant the applicant to be fined in the same manner as provided in Section 1-11 (Code 1976, § 1-1012).

-----**Applicant retains this page**-----

Certificate of Appropriateness (COA)

Required Materials

The following materials are the minimum required by the HPC in order to have a complete application. Incomplete applications will not be reviewed by the HPC until all information is submitted.

New Building and Additions

- * stamped set of architectural elevations (all sides)
- * stamped site plan (building, fencing, paving)
- * description of project
- * landscaping plan (saved and proposed vegetation)
- * description of construction materials
- * photographs of proposed site and adjacent sites
- * stamped set of architectural floor plans
- * proposed finishes (samples)

Minor Exterior Changes

- * description of project
- * description of construction materials
- * photographs of existing building
- * proposed finishes (samples)

Site Changes-parking, drives, and walks

- * site plan (building, paving, fencing, etc.)
- * description of construction materials
- * photographs of existing and adjacent sites
- * proposed finishes (samples)

Site Changes-fences, walls, and other site features

- * stamped set of architectural elevations (all sides)
- * site plan (building, fencing, paving, etc.)
- * description of project
- * landscaping plan (saved and proposed vegetation)
- * description of construction materials
- * photographs of existing site and adjacent sites
- * proposed finishes (samples)

Discussion Process

- * The HPC encourages an applicant to attend a meeting and discuss their proposed work and obtain recommendations from the HPC from the HPC prior to submitting an application for a COA.

Major Restoration, Rehabilitation, or Remodeling

- * stamped set of architectural elevations (all sides)
- * stamped site plan (building, fencing, paving)
- * description of proposed changes
- * landscaping plan (saved and proposed vegetation)
- * description of construction materials
- * photographs of existing and adjacent buildings
- * stamped set of architectural floor plans
- * proposed finishes (samples)
- * documentation of earlier historic appearance (restoration only)

Signs

- * architectural elevations (for signs located on the building)
- * site plan (for signs that are free standing)
- * description of project
- * description of construction materials and type of illumination

Demolition

- * complete site plan showing existing location of structures
- * complete site plan showing new development
- * description of project
- * description of construction materials
- * photographs of existing site and adjacent sites
- * proposed finishes (samples)
- * landscaping plan (saved and proposed vegetation)

Certificate of Appropriateness (COA)

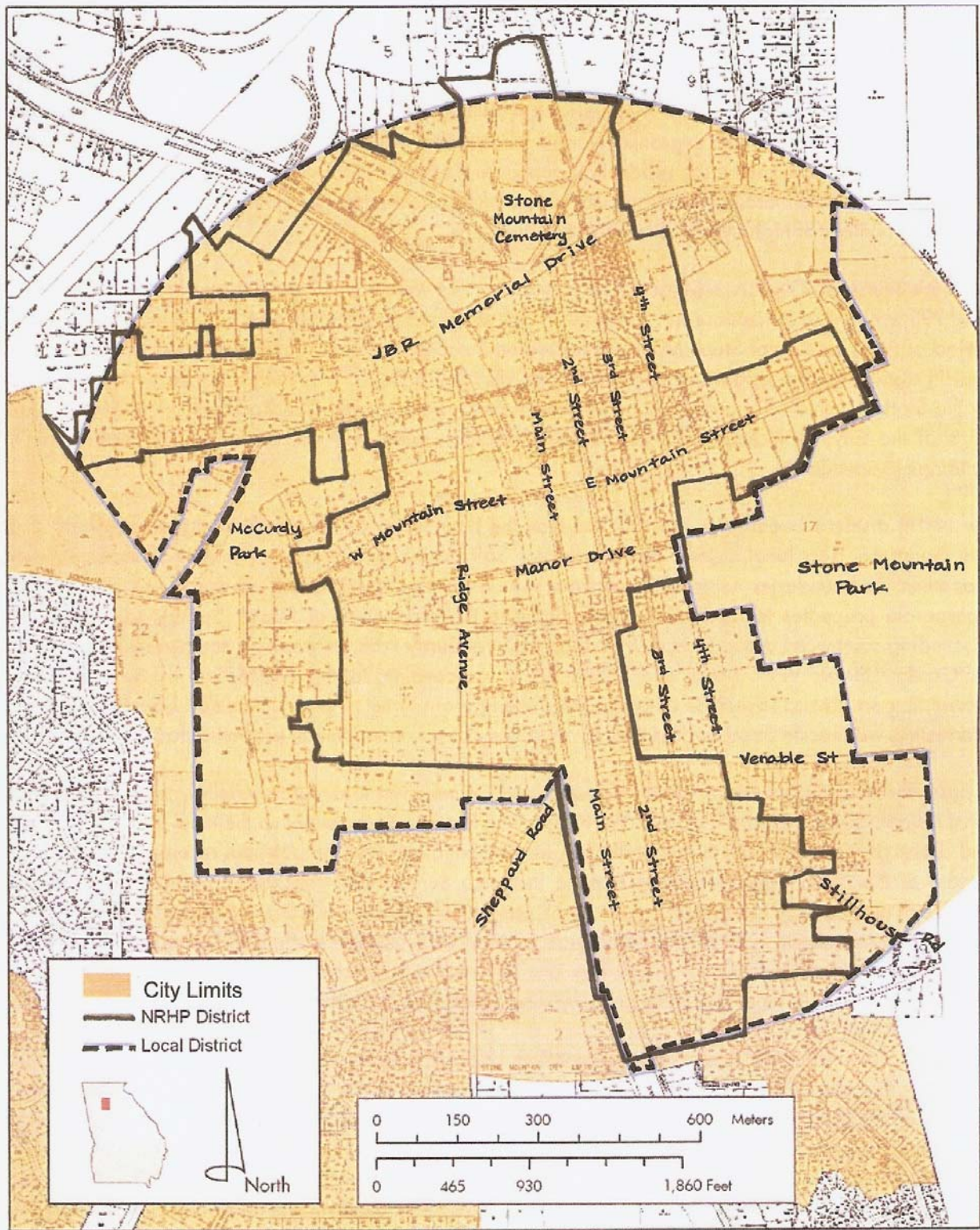

Certificate of Appropriateness (COA)

THE CERTIFICATE OF APPROPRIATENESS PROCESS

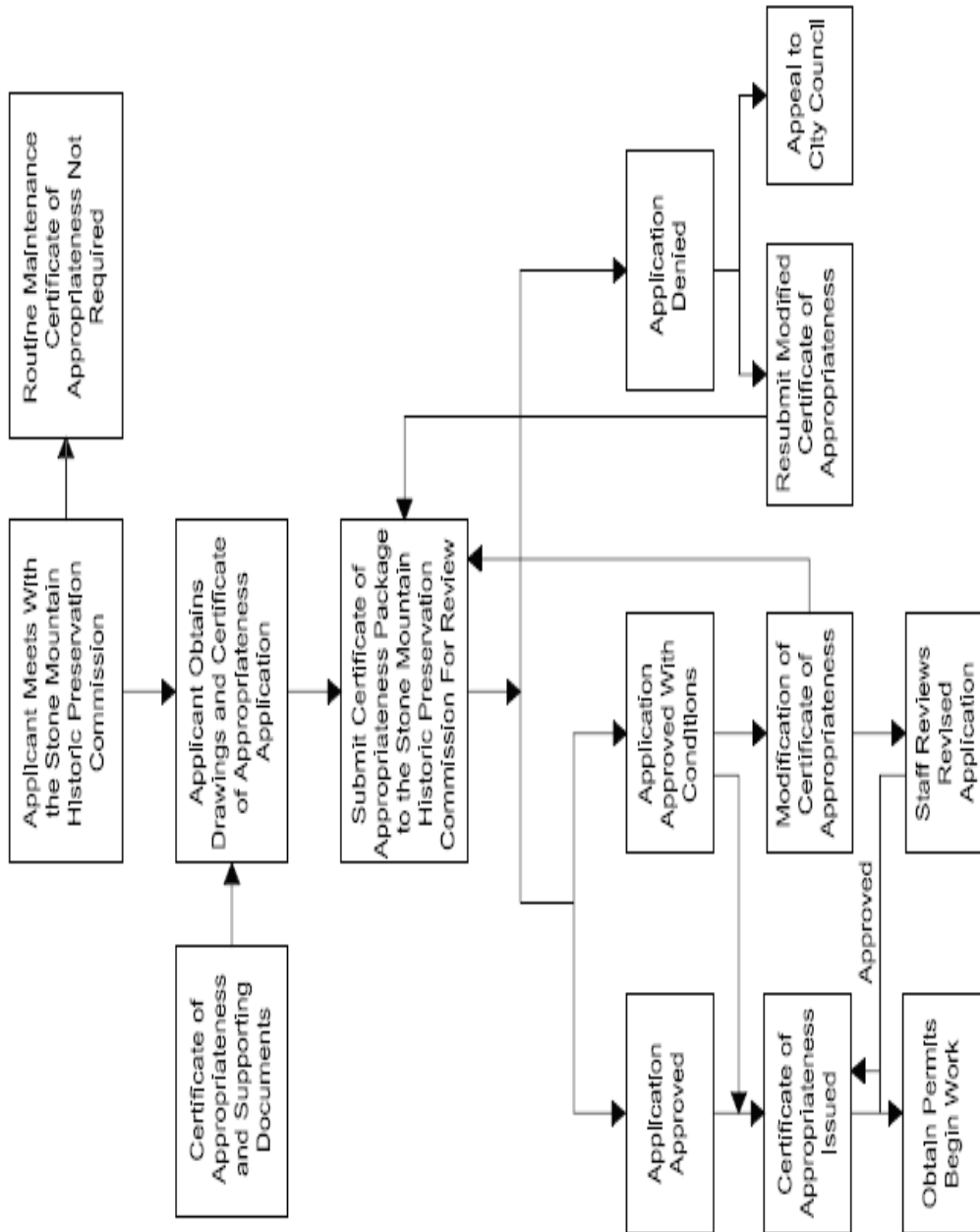

-----Applicant retains this page-----