

2005

An Exhibit on the History of Story in Games

Michael C. Leonardo
Worcester Polytechnic Institute

David M. Hickman
Worcester Polytechnic Institute

Matthew J. Girouard
Worcester Polytechnic Institute

Nicholas E. Bonatsakis
Worcester Polytechnic Institute

Follow this and additional works at: <https://digitalcommons.wpi.edu/gordonlibrary-studentreports>



Part of the [Digital Humanities Commons](#)

Suggested Citation

Leonardo, Michael C. , Hickman, David M. , Girouard, Matthew J. , Bonatsakis, Nicholas E. (2005). An Exhibit on the History of Story in Games. .

Retrieved from: <https://digitalcommons.wpi.edu/gordonlibrary-studentreports/13>

This Text is brought to you for free and open access by the George C. Gordon Library at Digital WPI. It has been accepted for inclusion in Library-related Student Project Reports by an authorized administrator of Digital WPI. For more information, please contact digitalwpi@wpi.edu.

SAVE THE PRINCESS:
A MUSEUM EXHIBIT ABOUT THE HISTORY OF STORYTELLING
IN VIDEO GAMES

An Interactive Qualifying Project Report

Submitted to the Faculty

of the

WORCESTER POLYTECHNIC INSTITUTE

in partial fulfillment of the requirements for the

Degree of Bachelor of Science

by

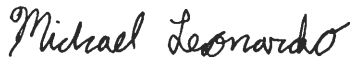

Michael Leonardo



Matthew Girouard

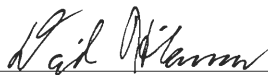

David Hickman



Nicholas Bonatsakis

Date: May 3, 2005

Prof. David Finkel, Major Advisor

Prof. Dean M. O'Donnell, Co-Advisor

Rodney G. Obien, Co-Advisor

Abstract

This project covers the design, construction and curation of a museum exhibit called, *Save the Princess: The History of Storytelling in Video Games*. To accomplish this we interviewed museum curators, researched museum design and studied electronic gaming history. The result of this project is a fully developed and interactive museum exhibit hosted in WPI's Gordon Library.

Table of Contents

Abstract	2
Introduction	4
Research	5
Field Research.....	5
Label Writing.....	9
Layout.....	12
Lighting.....	14
Artifacts.....	17
Procedure	20
Planning.....	20
Labels and Wall Text.....	21
Layout.....	24
Lighting and Aesthetics.....	26
Interactive Media.....	27
Enclosure for Interactive Hardware.....	31
The History of Storytelling in Video Games	35
Conclusions	72
References	73
Appendices	79

Introduction

Our IQP project focuses on the design and curation of the *Save the Princess: The History of Storytelling in Video Games* exhibition. To accomplish this goal, we did in depth research on the history of video and computer games made between the 1970s all the way up to the present day. We spent numerous hours playing old and new video games, analyzing their storylines, and discussing which ones had the biggest impact in society and throughout the entire gaming industry.

The project's second goal was to research the art of museum exhibit curation. We visited Boston's Museum of Science, and the Worcester Art Museum to help gather information on how to set up and run an exhibition. We interviewed Jim Welu, Worcester Art Museum's director, and he provided us with valuable information to help design the exhibit. Not only did we set up the display cases showing artifacts from gaming history, we also designed an interactive room which allows the visitors to experience video game history.

The exhibition is made possible through the cooperation of the Stanford University Libraries and the George C. Gordon Library at Worcester Polytechnic Institute. Stanford University was very generous to let us borrow artifacts from their own history of storytelling in video games exhibit. Worcester Polytechnic Institute provided us with the display cases, and space in the library to set up the exhibition.

Research

Field Research

As the first step of our research for this IQP we decided it would be best to visit a museum exhibit. We chose to visit the *Lord of the Rings* exhibition that was being featured at the Boston Museum of Science in October of 2004. We were told by our advisors that it featured a great deal of physical artifacts, as well as several interactive/media sections similar to the planned structure of our own exhibit. Upon visiting the museum, we learned several things about aspects of exhibit design that we later applied to our own.

Lighting was used to great effect in this exhibit. In many areas it was very subtle, very dim lighting in the pathways between artifacts and the various sections. This was combined with carefully placed lighting applied to each artifact that gave each its own character and made it stand out in its own way from the rest. For example, the actual ring that was featured in the movie had its own circular room. The room was very dimly lit, with the ring in a brightly illuminated case in the center. Another interesting example we noted was a case containing metallic armor and a sword. There was a bright light being projected onto the sword at a perfect angle to make the blade shimmer as if it were being held up to the sun.

The lighting of each section of the exhibit also helped guide the visitors from artifact to artifact intuitively. The majority of people most likely did not look at their map every time they finished looking at an artifact. Thus it was important that they could easily find another point of interest at any given time during their visit. The actual

locations of various artifacts were also taken into consideration. The ring mentioned above was centrally located in the exhibition area, presumably because it was a highly anticipated artifact and the majority of the visitors wanted to see it. Placing it in the center of everything made it very easy to find, and that the flow of people would not get bottlenecked as they could approach the room from several directions.

Upon making our way through the exhibition, we also took note of how the interactive portions were handled. There were several video feeds streaming clips of the film's creators offering insight into the artifacts. Each display monitor gave the user a choice of no more than a few different clips to play. The menu was simple, and the user was only given a button for each option, resulting in a very simplistic system. This was most likely done purposely, to not only avoid confusion among visitors, but also to ensure speedy operation of the interactive and allow as many people to experience it as possible.

There were however, several things we saw in the *LOTR* exhibit that we felt could have been better and that we would take note of when designing our own exhibit. Firstly, some of the interactive portions of the exhibit were in areas of the exhibition floor that would present problems if over crowded. In some instances, too many people would crowd around the video screen to either watch the current feed, or to wait to pick their own, and this would result in a major artery of the exhibit being somewhat blocked. It seems that it is important to consider to the best of your knowledge, how popular a given artifact/interactive will be and estimate how this will change the flow of traffic through the exhibit.

Overall, visiting the Museum of Science proved to be very helpful in seeing how to handle several inherent issues of exhibit design, and where problems can arise unexpectedly. The fact that this exhibit was somewhat similar in nature to ours, at least in its general structure, made it very useful. Despite the fact that we do not have access to such advanced lighting, it was still interesting to see various techniques in action. We did however, took away a great deal of information on how to handle crowd flow through lighting and more importantly through layout. Finally, we also learned a good deal about how to handle interactive media, something that is not mentioned readily in literature but rather must be experienced in person.

On December 6th, 2004, we made a visit to the Worcester Art Museum to learn more about museum curation. The museum was opened to the public in 1898, and is the second largest art museum in New England (Worcester Art Museum, 2005). Approximately thirty-five thousand pieces are displayed, including paintings, sculpture, decorative arts, photography, prints and drawings. Over five thousand years of art and culture are covered (Press Release). The staff at the Worcester Art Museum obviously has a great amount of experience in exhibition design and curation.

We met with the Museum Director, Jim Welu, to discuss curation. All of us were hoping that we would be given a few pointers on how to make a successful exhibition. At the start of the meeting, we discussed the importance of the exhibition title. Welu specifically mentioned that the title should be a thesis, and it has to be catchy. The visitor should be more interested to learn about the subject matter after reading the title. Also, the title needs to be easily understood by the target demographic for the museum exhibition.

The most important topic Jim Welu discussed next is the label creation process. The criterion for writing the labels is fairly simple; they should be written like a dialogue, and written at the sixth grade level. We were very surprised to learn that the labels the Worcester Art Museum use often take many weeks to write. The tricky part about label creation is determining how much information to include, and determining how to explain the subject matter in the simplest manner. For the purpose of the IQP, we will not spend anywhere near as much time making labels as the Worcester Art Museum, but we will follow the general guidelines.

During the interview, we discussed field testing. We found out that the average time a visitor stays in an exhibition is thirty minutes. The flow of the exhibition needs to be highly efficient to maximize the amount of time the average visitor can spend reading the labels, and examine the artifacts before losing focus and interest. Anything helping the visitors' journey through the exhibition efficiently is a big plus. Even arrows on the floor or signs help out in this regard. Jim Welu said that the goal of the exhibition is to educate the target demographic as much as possible, and to have an enjoyable time. Oftentimes the visitors take breaks, and have to resume the exhibition at a later time. Welu mentioned that the exhibition has to "make sense" from different starting locations.

Lastly, we briefly discussed the importance of interactive media in an exhibition. Jim Welu stressed that the purpose of the interactive media is to assist with the learning, and to not overpower the rest of the exhibit. For instance, in the case of our exhibit, the video games that the guests can play must have historical significance, and explain why the game is very important. We also learned that the interactive media should be fun, educational, and very simple to use. For instance, if the player cannot pick up the

interactive media controller and immediately start the presentation or video clip, there is something wrong with the interface, and the visitors will quickly lose interest.

Label Writing

In the past, we saw an exhibit on Leonardo Da Vinci at the Boston Museum of Science. One of the most memorable parts of the exhibit was a collection of sketches of the human muscle layer. The reason we remember it was because of reading the labels that accompanied the sketches; labels that told how Da Vinci dug up recent dead bodies and dissected them so he could draw their insides. That is why labels are not trivial and could make all the difference in how the audience views an exhibit.

The main task of a label is to explain an item. It may seem like a simple and obvious part of an exhibit, but label writing can be exhaustive. Some interns at the Worcester Art Museum spent up to three months designing less than a half dozen of labels for an upcoming exhibit. “There are many factors to consider when making labels,” according to Jim Welu, curator of the Worcester Art Museum (Welu, 2004). All must answer three questions: what is the article, how much should you be told about it, and who is reading this label.

There are many important things to consider in the label’s content. Deciding what it is you want to tell is crucial. It is important to give basic facts, but there is more to it. When an audience member sees an artifact, they want their unspoken questions about it answered. In a lot of museums, employees ask volunteers, “What most common questions come to mind?” That information is later used to actually decide what details

make it to the final draft of a label. Another goal for the content of a label is to promote thought but it is important not to try to *tell* the reader how they should feel about the information. A label such as:

*Mona Lisa,
Leonardo da Vinci 1503 - 1506
This piece invokes a feeling of sadness and interest with the expression of the subject's face.*

is not the intended goal. Instead, the goal is the creation of a label such as:

*Mona Lisa,
Leonardo da Vinci 1503 - 1506
The subtle smile of the Mona Lisa is world famous. Leonardo da Vinci used his finger to erase outlines and create an impression of fuzziness.*

which invokes interest and allows the viewer to decide how it makes them feel on their own.

It is very important to consider how much information to give the audience.

Giving too much information can dissuade the reader into disinterest about the related artifact. Too much information could bore the reader and in turn result in them missing important facts you want to relay. An example of too much information (another label for the Mona Lisa):

The Mona Lisa (La Joconde in french) by Leonardo da Vinci is the most famous painting of the Louvre museum in Paris, the capital city of France. Leonardo da Vinci was born in 1452 in Vinci near Florence in Italy. He was a genius in many fields including painting, music and engineering. Impressed by the Italian renaissance and in particular by Leonardo da Vinci, François the first, the King of France at that time, who was fighting a war in Italy, brought him back to France. Leonardo da Vinci painted there the Mona Lisa between 1503 and 1506. The subtle smile of the Mona Lisa is world famous. Leonardo da Vinci used his finger to erase outlines and create an impression of fuzziness. Leonardo died in 1519 in Amboise, one of the favored towns of the king.

Labels like that are seldom read thoroughly by average exhibit goers. Being concise and to the point will keep the reader's attention and allow them to move through the entire exhibit at a pace that matches their patience. Conversely, it is possible to not include enough information. This could possibly result in the reader not obtaining crucial information regarding the artifact. Furthermore, if the label is too short, the potential reader may consider it to be unimportant and not read it at all, and possibly miss out on information that would enhance their experience significantly.

It is of great importance to know and understand who your audience will be. You must know what their levels of prior knowledge are, learning styles, age, and what type of social groups they will be in (Writing Text and Labels, 2, 2000). No matter what the audience, if the subject matter is not something universal, such as in the case of a video game or any technology related exhibit, it can lose a lot of traffic over it. It is suggested that the labels are written in a very watered down manner. For a gaming exhibit, instead of using the term "Frag," which non-gamers don't understand, exhibits would have to use "Kill" so that nobody in the target audience, whom might not be all gamers, will miss key information due to unfamiliar terminology. Undershooting the target audience can also hurt if you make them feel like they're being babied. It is also important to consider the audience in regards to the general style of the writing and what points are to be emphasized more than others. For example, if the audience is mainly engineering students, such as in the case of an exhibition held at WPI, it would be better to emphasize technical aspects of artifacts rather than artistic aspects. This would ensure that more of the audience's interest would at least temporarily be caught and hopefully sustained from other content of more interest.

Audience research has been conducted at numerous museum exhibits across the world. Results from the field testing have suggested that visitors seldom read labels, they stop at less than half of the exhibition components, are more likely to use trial and error methods rather than written instructions for interactive exhibits, and children are more likely to engage in using the interactive exhibits than adults (Writing Text and Labels, 3, 2000) . Also, the results stated that visitor’s attention to the exhibits “decreases sharply after about half an hour.” The conclusions from the research that the labels need to be very concise, promote thinking, entertaining and informative.

Layout

The layout is critical to the success of any museum exhibition. The orientation of the artifacts and display cases must ensure that the visitors will be able to follow the exhibit. Just like a book, the exhibit has to make logical sense from start to finish, or else the visitors will be very confused and frustrated by the exhibit. We spent many hours designing the layout for the History of Storytelling in Video Games exhibit, and there were many different layout styles that we could have used.

There are five different types of circulation patterns that are the most common in exhibits. The five patterns are illustrated in figure R1. The *arterial* pattern is defined as a continuous path which offers no alternative routes. This type of design is very suitable for linear sequences, since there is only one main route that the visitor can take to navigate the exhibition (Belcher, 112, 1991). The biggest downside to this design is that if a visitor wishes to refer back to something that he or she has already seen, then it can

often times cause congestion if it is a crowded exhibition.

The “*comb* pattern consists of a main path supplemented by optimal alcoves” (Belcher, 113, 2005). This would allow the visitors to study without being jostled, and can potentially allow for two way flow if there is enough space. The *comb* pattern also allows the visitors to study certain parts of the exhibition at their own will without getting in the way of others.

The *chain* is similar to the arterial scheme due to its linearity (Belcher, 113, 2005). There is a series of self contained spaces within a *chain* that provide the visitors the opportunity to study. The one major downside to this pattern is that there is generally a high amount of congestion near the doorways. On the plus side, the visitors often times get a considerable amount of freedom within the exhibition spaces (Belcher, 113, 2005).

The *star* formation can be very advantageous for exhibitions that have no linearity, and want to provide the visitors with the most amount of freedom. The visitor can choose the sections of the exhibit where he or she wants without holding up traffic (Belcher, 113, 2005). One of the downsides to this layout is that the central area can become extremely congested. The last type of basic pattern is the *block*. In a sense, it is not really a system since it provides the visitors with the most amount of freedom. Only the locations of the entrance, exit, and exhibits (display cases) affect the visitor flow (Belcher, 113, 2005).

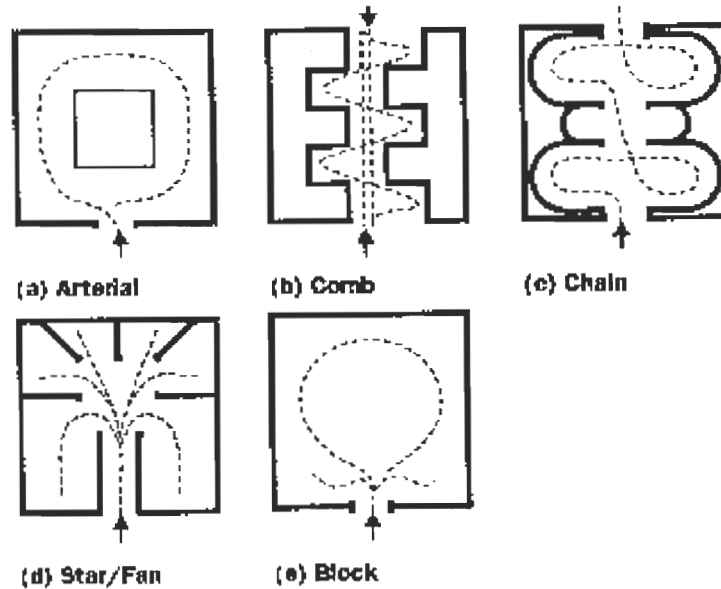

Figure R1
 These are diagrams of the various circulation patterns (Belcher, 114, 1991)

Lighting

A very important yet often overlooked element of museum exhibit design is lighting. Lighting can simply be present to allow the museum exhibit to be visible, but it also can completely alter the overall look and feel of an exhibit. The right forms and amounts of lighting can adversely change how artifacts are perceived and also in some situations create a sense of dynamics.

It is important to not only use controlled lighting to enhance exhibit artifacts, but also to use and constrain the effects of natural light as well. This delicate balance of natural and artificial lighting can in essence be considered a science. “Lighting for Museums and Art Galleries has a unique set of priorities, those of conservation and effective display,” (Shaw, 1, 2005). The first important thing to consider in the lighting

design of any exhibit is the role of natural light (i.e. sunlight). Sunlight is a very dangerous light source in that it is very effective due to its strength and color range, however it has very high UV content and is very inconsistent at times, thus making it difficult to control. Additionally, sunlight can be destructive to many types of fragile artifacts due to this UV content and its general intensity, care must always be taken when allowing sunlight to shine on these artifacts. It is still important to allow sunlight wherever possible, particularly in more artistically-based museums because it has a certain psychological effect of allowing the visitors to feel like what they are looking at is real. It is possible to obtain these positive effects of sunlight while still preventing the negative aspects of natural light by using tinted double paned glass (Shaw, 1, 2005).

There is a wide variety of artificial lighting available within the museum realm, thus it is also important to consider this type of lighting. It is typical to use halogen or fluorescent lighting fixtures to achieve the maximum color depth, however in some cases fluorescent lighting is preferred as it prevents the yellow tinge of conventional filament lighting. It is also true however, that filament based lighting gives a much more warm effect, and thus a good combination of the two is advised (Shaw, 1, 2005). In recent years the use of fiber optic lighting has become much more common. In short a fiber optic system works by projecting a light source into a fiber optic cable. The cable lines areas of the artifacts and lets light escape from it at select points. There are several advantages to this over conventional lighting methods. Firstly, this method offers far more control, as the light emitted from a fiber optic cable is much more precise than any other light source, this level of control can be seen in the photographs in figure R2.



Figure R2
(“Museum & Gallery Lighting”, 2005)

Note in the leftmost photo how the light is focused only on the jewels further emphasizing that artifact. Secondly, this type of lighting almost completely eliminates negative aspects of conventional lighting such as UV. Finally, since the original light sources are not actually in or near the display cases, it is less of a risk to the artifacts if/when a light needs to be changed (“Museum & Gallery Lighting”, 1, 2005).

Past the choice of what type of lights to use, it is also important to consider light placement. In professional museum exhibits and art galleries, such things as beam angle and wattage are always considered in lamp placement. It is suggested that proper wattage selection and placement is chosen over dimming lights. Additionally, various light fixtures tend to vary with their manufacturers and thus it is important to take this into account when purchasing lighting (Shaw, 1, 2005).

Once the lighting needed is determined on the artifact level, there are several approaches that can be taken. The “Black Box” approach is one example and can be seen in practice in the following photograph (figure R3) taken at the Chester Beatty Library in Dublin, Ireland.



Figure R3
("Museum & Gallery Lighting", 1, 2005)

In this design pattern, the room housing the exhibit is kept completely dark while there are extremely bright lights illuminating the artifacts. This greatly emphasizes the artifacts while still giving the room enough ambient lighting. In situations where the artifacts demand less light this technique would only be used with some amount of general lighting present (Shaw, 2005).

Artifacts

No one can dispute the importance of artifacts and their placement, selection, and presentation in a museum exhibit. Each artifact serves as visual memory key, a way for viewers to understand and retain the historical information and ideas from an exhibit. The three important basics to artifacts in exhibits are the selection, prominence, and relationship (McKay, 1, 1982).

The most vital issue when addressing artifact selection is choosing artifacts that fit in the theme of your exhibit. While some pieces may be of great interest or make great

center pieces, if they are not part of the theme they should not be part of the exhibit. For example: the original Darth Vader helmet displayed along side a Star Wars video game in an exhibit on the history of story telling in video games. While the helmet is of great interest and prominence, it is not part of the core theme and is extra. Artifact selection such as that can throw the viewer off from the idea and concept the exhibit is trying to express.

The second thing to consider in using artifacts is prominence. Some pieces are more important than others. They could be more significant or make a crucial point in the theme of the exhibit. If this is not apparent by itself then it is the exhibit designer's responsibility to bring this fact to the viewer's attention. This means making the artifact stand out more from the other through careful presentation. There are many techniques for doing this. One way is height, physically placing the piece even one foot higher than many others of its type. Viewers will then tend to associate more importance with a higher object. Care must be taken not to elevate the artifact too high and make it difficult to view. Another method is color contrast, perhaps placing a solid color block against the artifact. Even just placing the object alone and first in the exhibit achieves the right effect.

The last point to focus on is relationship. While an entire exhibit has a singular theme, each individual section of the exhibit can have its own relationship. These relationships can be trivial such as grouping artifact by time: decade, century, or any other measure of time. Some more in-depth grouping might consist of groups for regions, such as the effect on each part of the country of whatever the exhibit is about. More imaginative groups can obviously be made. The point is that viewers can look at a group

and ask, “What do these artifacts mean together?” and be able to figure it out. Without that ability an exhibit feels random and unprofessional.

These are just the most crucial topics for artifacts; there are many more things to consider regarding presentation of artifacts. Lighting, angles, spacing, and other things come into play, but have few rules. Most presentation related things are up to the artistic direction of the exhibit designer. The most important overall test of an exhibit design is whether the exhibit actually works. If it communicates the right message to the viewer then it is successful.

Procedure

Planning

The first several weeks of this project were spent doing extensive planning. Considering the fact that it would be a three term endeavor, we realized early on that we needed to lay out a road map for budgeting our time early on and attempt to stick to it as closely as possible. Some significant primary topics from this first phase of the project were the overall design and construction of the exhibition, financial budget, logistics, and required research.

The majority of the artifacts for this exhibition will be on loan from Stanford University. However we were not required to follow the style or theme of their exhibition. Thus we had to decide what aspect of videogames our project would focus on. We ended up deciding that given the artifacts, it would be best to stick to a theme similar to Stanford's, and thus we decided upon the history of storytelling in videogames as our theme. In addition to the theme, we discussed the overall structure and feel of the exhibition, specifically, aspects not pertaining to the artifacts themselves such as visual balance, lighting, and crowd flow. Given the audio-visual based nature of our topic, we felt that an interactive media section would enhance the overall experience of the exhibition greatly. Finally, we agreed that a catalog would compliment the exhibition nicely (see Appendix 10).

During this phase of the project, we also discussed and planned many logistical aspects of the exhibition. We chose Gordon Library as the exhibition area due to its availability and accessibility. We also confirmed the amount of space we would be

allotted, the amount of cases we'd be given to use, and a designated secure area for our interactive media section to prevent theft and avert noise. Furthermore, we established contact with Stanford in order to assure that the artifacts would still be available to us and to plan when and how they would be shipped to us. In order to continue with the planning, we wanted as much information about the artifacts as possible, so we requested detailed information. The University replied with an artifact listing that contained a small amount of information for each item listed.

Finally, we discussed necessary research for the project. Due to the fact that the exhibition was based on the history of storytelling in videogames, we felt that we would need to thoroughly research that subject. This research would help us understand the exhibition topic and thus give insight into its design. It would also be presented in the form of a timeline, highlighting important events relating to the topic (see Appendix 3). We would also need to research the design and curation of museum exhibits, as that is the other major component of the project. For this we would not only consult written materials, but we would also visit established exhibitions and meet with professional curators.

Labels and Wall Text

While the artifacts are the most important part of an exhibit, the labels are not far behind. Labels tell you what you are looking at and why it is important. We wanted to make sure that was exactly what happened in our exhibit. To do that we decided we needed to formulate a template for the labels, one that would be simple and concise. We

wanted to ensure readers understood why an artifact was relevant to the history of storytelling in video game without overwhelming them with information.

We developed a template as follows:

Game or Item Name, Year of Release

Developer

What type of media is it (cartridge, CD, source code)

Up to two sentences of detail describing importance or relevance.

We chose this template for a few reasons. It put forth the most important information first, the title and year of release. This way people could know what they were looking at and what time period it came from. Secondly we had the developer's name which was important so developers were given credit for their work. Then, in case there was any confusion to what the actual artifact was or which item the label was referring to we included a line telling what type of artifact it was. In most cases they are "Demo Software for PC", "Video game for [NES, Super Nintendo, etc] or some kind of paper item. A select few of the artifacts were of more significance or needed to be further explained. For these artifacts we included a very brief description (up to two or three sentences of detail) to compliment the rest of the label.

Once we decided on a format for the labels, we developed a process for actually writing them. We divided the labels amongst ourselves based on display case. Once we each completed our assigned labels, we met as a group to discuss each one. By approving each label as a group we reduced the chances of any being unclear or confusing.

As far as actual appearance went, we were careful to make sure the labels were easy to read. After reviewing several type faces, we used the font, “Jolt Wide,” as described in the aesthetics section. Using that font, we printed out several test labels in different font sizes. We decided font size 18 was the easiest to read while not being overly large.

Lastly, we realized that printing the labels on white paper alone would not be a very attractive touch to the exhibit. To make the labels look more professional we decided on framing each label with either black poster board or foam board if it was a large one. For the foam ones we used blue foam board (hex color value #0E459F). The foam board has a 5 mm white edge that will make all the labels have some depth. Using other pieces of foam board connected perpendicularly we made labels stand up on their own (refer to Figure P1). Not all labels were made to stand because some artifacts will be on the wall and the labels for them can just be flat against the wall as well.

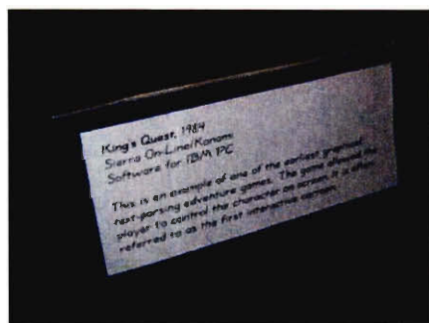

Figure P1
An example of one of our foam board labels.

Wall text was another area we needed to consider. Originally we planned on obtaining large prints of notable text from our history research. However, our resources turned out drastically lower than originally thought and we could not afford professional large prints. Instead we opted for displaying a few paragraphs the size of a piece of paper held horizontally. This way we wouldn't have to abandon wall text altogether and we

could still afford to do it ourselves. We used a much larger font size, approximately 50 depending on how the text fit on the lines. Otherwise we used the same foam backing as the labels.

All of our preprinted labels and wall texts can be found in Appendix 9. Additionally, information regarding the storage and organization of the labels can be found there as well.

Layout

The exhibition space available for the exhibit is at WPI, in the third floor of Gordon Library. A layout of the available floor space, and the exhibition design plan can be seen in Appendix 2. When entering the third floor, the visitors will be brought into the exhibition environment (only the main stairs bring the visitors to the third floor). We had many goals when designing the layout. First of all, we want the visitors to be able to effectively travel through the video games history in a linear fashion. Storylines over the past few decades have evolved from being extremely simple, to very in depth and complex. Allowing the visitors to experience each of the different eras in storytelling would be the most effective way to present the material. We selected the *arterial* layout due to the space limitation, and to provide the visitors with a linear path to study the artifacts. The exhibit will begin right after exiting the stairs leading up to the third floor, and loop around back near the stairs again. For the exhibition, this style of layout is very appropriate since the display cases will be laid out in chronological order.

Another design feature implemented into the exhibition is the isolated ‘Interactive Room’. This room will use the *comb* layout, and will have four desks/tables set up, in addition to two carousels. The visitors will be able to watch video clips, play old video games that were significant in storytelling, and play PC games. The layout allows the viewers to choose which games they want to play, and which video clips to watch. The space in the interactive room is relatively limited, so it will be difficult to accommodate more than 10 guests at a time. There was no way to avoid this bottleneck unless the interactive room was placed in the exhibition area, but this would cause many more problems. The reason the interactive room is separated is to allowing the games and clips to run during Gordon Library’s operating hours. Having all of the interactive equipment in a closed room will further enhance security, and it will also prevent any additional noise from disturbing the other students in the library who are studying.

The geographical orientation for the artifacts is the most critical element to the layout. Even though the *Save the Princess* exhibit is not huge, the items need to be placed in logical locations, and have to flow between one another. For example, if the 1970s case is right next to the modern era case, the visitors will be left wondering what happened to the games and consoles made in the 80s and 90s, and will become lost in the exhibit. For the purpose of the *Save the Princess* exhibit the display cases will be placed in chronological order. The visitors starting the exhibition will be directed to the display cases explaining the earliest games. As they travel through the exhibition, they will learn more about the modern day storytelling in video games. The visitors will be able to understand the correlation between storytelling and how technology has aided in allowing developers to implement more in-depth and complex plots in games.

The internal environment design of the exhibit is incredibly important in capturing the attention and excitement of the visitor (Belcher, 113, 1991). The entrance for the exhibit will be right next to the stairs in the third floor of the Gordon library. Although no tickets or souvenirs will be sold for the exhibit, there will be eye catching posters, pictures, and artifacts that will draw the visitor into the start of the exhibition. Research has shown that visitors are attracted to dramatic objects (Belcher, 114, 1991). A cardboard cutout of a famous videogame character, a poster or a model of a video game console is very eye catching. These need to be placed before the start of the exhibit to intrigue and attract more visitors.

Lighting and Aesthetics

Another very important aspect of exhibition design we had to take into account in approaching this project was lighting and general aesthetics. We wanted to design a look and feel that would enhance the visual quality of the exhibition, while not being distracting. We would do this by using what lighting we have available to us and also through the use of a specific color scheme and type face for all related text.

We were somewhat restricted in terms of lighting possibilities, as lighting fixtures are rather expensive, thus our design had to incorporate the use of lighting already present in the Gordon Library. The planned exhibition area features ceiling mounted track lighting that we can position anywhere we feel is necessary. As the artifact cases are the most important portions of the exhibition, we decided to position heavy amounts of lighting over each case, to further emphasize the artifacts inside. This will not only

draw attention to the cases, but will also make the artifacts (many of which are text based), as well as the labels, easier to see/read. We also had to take into consideration what the lighting would be in the interactive media room. Due to the fact that this room consists of primarily monitors and television screens, we felt it best to make it a low light room, thereby reducing glare and making the displays easier to see. Our final concern involving lighting was what the effects would be on the artifacts. In many cases lighting can degrade such materials over time, and on Stanford's request, we will rotate the artifacts as well as flipping certain ones on a consistent basis to avoid this degradation.

In choosing a color scheme we wanted to use colors that blended well together and would not be overly attention grabbing. We ended up deciding on black, blue, and dark red. These colors will blend well with any type of artifacts and also should work well with the colors in the exhibition area of Gordon library. In addition to this, we chose a type face called "Jolt Wide". This particular type face is very futuristic looking yet somewhat simple. It will be applied to all printed material associated with the exhibition. Examples of both the type face and color scheme can be found in Appendix 7.

Interactive Media

Due to the nature of videogames as an electronic medium, we came to the conclusion that an interactive media section would be a well placed addition to our exhibition. Though the exhibit features a large range of physical artifacts, it is difficult to convey certain aspects of the evolution of storytelling in videogames through these

artifacts alone. Our final interactive media section design contains two main sections. The first section includes several playable videogame consoles, while the second consists of a collection of video clips to be looped continuously (detailed outline of all items included can be found in Appendix 4).

During the early stages of design, we agreed upon the fact that this section of the exhibition would require its own room. Sound is an important element of both playable consoles and video clips. Confining this section to its own room would be the best way to prevent excessive noise in the otherwise quiet library while still allowing for freedom in terms of sound. Once we secured a room and tables we drew up a layout to be followed when actually setting up the exhibit. This layout can be found in Appendix 2 along with the layouts for the rest of the exhibit.

The playable games portion of this section will include two consoles, the Sony Playstation and the Nintendo Entertainment System. We chose these two consoles because they represent two very different eras in storytelling. This is a good way to present contrast and evolution, as well as to create a diverse experience for our visitors. For the Playstation, we chose to include the game *Final Fantasy VII*, developed by Square Enix and released in 1997 (Kasavin, 1, 1997). This game is significant in that it is a more modern chapter of a series that spans the history of storytelling. Since the Nintendo Entertainment System featured many games relevant to the earlier stages of storytelling evolution, it will include several games. *The Legend of Zelda*, released in 1987 by Nintendo (Nintendo, 2005), *Mega Man*, released in 1987 by Capcom (Nutt and Spear, 2005), *Ninja Gaiden 1*, released in 1989 by Tecmo (Skerritt, 2005), and *Super Mario Bros. 3*, released in 1990 by Nintendo (W, 2005) will all be included for use in this

console. Due to the amount of games made available for this exhibit, the games will be switched out and rotated biweekly. This will also maintain viewer interest should a viewer wish to visit the exhibit repeatedly.

The video clip section of our Interactive and Media section will be a very important component of the exhibition. As mentioned earlier, we have arranged to have two computers dedicated to running these video feeds at all times during the running time of the exhibition. The clips are all in a format compatible with a media player called Nullsoft Winamp (www.nullsoft.com). This player allows for a playlist being setup that can be displayed in a random order. The video clips that will be included range from interviews with game developers, game trailers, game history features, and gameplay footage.

It is very apparent that there would be no video games if not for the many diligent game development teams that exist. Though it is possible to give insight on a game based on your own experiences with it, the developers of that game can often give very interesting insight of their own. For this reason we have decided to include several game developer interviews. Upon the approach of any game's release date, there is usually a good amount of these interviews on sites such as *Gamespot.com*, and this was where many of our interview clips were found. Specifically, our media section will include three interviews with the developers from BioWare on the creation of *Star Wars: Knights of the Old Republic*. These interviews discuss many aspects of the game development process, both generally and in specific relation to this game. We also found a significant lecture, held with a panel of leading game developers and hosted by Vince Braudy, a co-founder of *Gamespot.com*. In it, the panel discusses the effects of technological advances

on the game industry, particularly in the area of computer graphics. Permission to use many of these interviews and clips was given formally to us for use in the interactive room. In Appendix 8, a letter written by *Gamespot.com* is available that mentions usage agreement for their material.

When searching for relevant video clips, we managed to uncover a significant number of original trailers of many games featured in our timeline and pertinent to the exhibition. As videogames feature an increasing amount of cinematic qualities, the line between the game and film industries is becoming distorted. These game trailers are proof of that. They feature just as much cinematic quality as trailers for feature films and are essential to the promotion for an upcoming game. We will feature trailers from games such as *Star Wars Galaxies: An Empire Divided*, *Grand Theft Auto 3*, *Resident Evil*, *Resident Evil 4*, *Metal Gear Solid 3*, *Max Payne*, *The Legend of Zelda: The Wind Waker*, and *Star Wars: Knights of the Old Republic*.

We also came across several “History Of” features that we will be including in our media section, particularly ones that focus on the Metal Gear and Grand Theft Auto series. These features outline the history of the given series highlighting key games and aspects through spoken dialogue and gameplay footage. They are very well done, and do an excellent job at showing the progression of the games and the industry as a whole.

Finally, we decided that it would be best to include several video clips of gameplay footage. For this, we included clips we found online, as well as several clips we made ourselves. The games featured here include *Super Mario Bros.*, *Final Fantasy*, *Castlevania*, *Grand Theft Auto 3*, and *Half-Life*. To create these clips, we used several

consoles and a PC video capture card. Microsoft's Windows Movie Maker was used to edit the clips, and to add titles.

In organizing this video clip section, we made sure to take all steps necessary in order to ensure that we were not infringing on any copyrights. All of the video features and game trailers as well as some of the gameplay footage clips were found on Gamespot.com. We wrote to the website asking if we would be able to use their clips, and they responded saying it would be fine as long as we kept the Gamespot logos intact on each clip (see Appendix 8 for e-mail).

Our final task in designing this section of the exhibition was to determine what methods we would use to keep the hardware secure. The fact that the section will be contained in its own room was a good start, however additional care needed to be taken since the room will not be monitored at all. For the PC the security measures we decided on were quite simple. Since the computer is not intended to be interactive (it just runs video loops), we will be able to start the loops then remove the keyboard/mouse altogether. This will prevent tampering and since a computer and monitor are too large to steal easily this would suffice. As for the playable consoles, we decided on an enclosure, which was designed and constructed by us. The details regarding this enclosure can be found in the next chapter.

Enclosure for Interactive Hardware

As mentioned previously, playable consoles are a significant portion of the interactive media section of the exhibition. Given the fact that these consoles will be

available for use during all regular library hours, we determined that security would be a concern. It would not be logistically possible to have a person constantly monitoring the interactive media room, thus we felt the best alternative would be some sort of restraint system. It would prevent the consoles from being stolen, tampered with, or damaged.

Upon making the decision to design such a system, we compiled a list of requirements that the final solution would have to satisfy. It would have to keep both a Nintendo Entertainment System and Sony PlayStation generally secure. Specifically, it would need to provide a deterrent from people stealing the consoles, games or controllers. Additionally, it would limit people to simply playing the games and restarting the consoles. All wiring and game selection would be restricted.

After pondering the requirements, we began considering different ideas on how to go about constructing a system that would do the job best. Originally we juggled the idea of possibly modifying the consoles themselves to allow them to be chained to a fixed structure. However, for several reasons we quickly dismissed this as a viable option. While this method prevented theft, it did not prevent tampering, and games or controllers could still easily be stolen or damaged. At this point we came to an agreement that we would need a complete enclosure system. Our initial plans called for a wooden enclosure; however after realizing that this would prevent visitors from actually seeing the consoles, we opted for a transparent enclosure. Since cost was an issue, we decided to house both consoles in a single case. This case would have openings for video, power, and controller wires, as well as slots that would allow someone to use the reset and power buttons. As these consoles generate significant heat, we also incorporated several air vents into our design to prevent overheating. It was difficult to predict how much heat

the two systems would generate, so we included air vents on the top and sides of the enclosure to ensure enough flow. Finally, we decided on a lock and chain, attached to the enclosure and the table to prevent someone from stealing the enclosure itself.

At this point we needed to figure out how to build such a case. We had a few general conditions to consider while making construction choices. We didn't have much access to a workshop and we didn't have a large budget. We had to try to satisfy our requirements with inexpensive components.

We reasoned that with our lack of equipment, we couldn't construct the case from scratch (i.e. cut/build each and every side, attach all pieces). We needed sections that were already fairly built and to mix and match them. Specifically we needed some way to implement the transparent window for the case. This led us to two ideas: plastic or Plexiglas. Plexiglas would require machinery for cutting and sealing, machinery we didn't have access to. Also, Plexiglas was fairly expensive. Instead, we considered plastic. We would need a fairly pre-constructed plastic casing. We realized that certain Rubbermaid containers were perfect for our purposes. They were clear, large enough for both consoles, and very sturdy. Therefore we chose the Rubbermaid.

Proving even more useful, the Rubbermaid containers could also be cut fairly easily. For security, we cut semicircles out of the edge of the case. This way we would screw the case against a platform made of wood, and the wood and plastic together would form the hole for controller wires and power/video cables. These holes were sized specifically so that only the wires themselves fit through, not either end where the plugs were. This meant that the wires could not be pulled out and stolen since the plugs didn't

fit through the holes. Additional cutting was used for the ventilation and reset buttons that our design called for.

The wood plank we attached the case to was about one inch thick, making it heavy enough to keep the display stable. We painted the piece of wood black for aesthetic purposes. We considered how to implement our security to prevent the entire case from being stolen. Our conclusion was to screw down a steel ring to the wood and have five feet of sized chain with a lock to secure the entire case to the display table. Once the painting, cutting, and sealing (screwing it down to the wood) of the case was done, we added a few minor details, such as lining for where we cut, and labels for the systems themselves (refer to Figure P2) .



Figure P2
Our constructed interactive hardware case.

Information pertaining to the storage of the enclosure until the exhibition time, as well as additional photos of it can be found in Appendix 5.

The History of Storytelling in Video Games

The curation and design of a museum exhibition requires an extensive understanding of its theme and content. Everything from the artifact labels and placement to the overall flow of the exhibit requires consideration and knowledge of the artifacts as well as the overall topic. For this reason, we felt it was necessary to do a significant amount of research on the topic of our exhibition, the history of storytelling in videogames.

The following section describes the history of storytelling in videogames. It not only focuses on specific games that had a significant impact on storytelling, but it also gives an overall synopsis of the evolution of videogames as a method of presenting story. Due to the fact that the artifacts are the primary focus of this exhibition, we paid special attention to highlighting their relevance. Our coverage in this next section is not fully linear since different sagas and genres overlapped each other. This is particularly evident toward recent times, when simple storylines developed branches and different plots.

The Video Game Era

In the beginning there was the simplest of all storylines; the protagonist vs. the antagonist. You either won or lost. The technology at the time could not meet the requirements for detailed graphics or immersive plots, and it held back developers from including much story in early games. Despite the lack of more sophisticated technology and storylines in the 70s, there were still important developments. Many video game

genres were developed that would serve as a foundation for storylines to come. Due to the limited technological advances during this time, it was quite common for a video game to contain simple graphics such as shapes and lines. A popular and memorable game developed by Nolan Bushnell in 1972, *Pong*, is an excellent example of the simplicity and limitation of video games (Damaria & Wilson, 20, 2004). This game featured two lines that acted as paddles along boundaries of the video screen, and a square “ball” to be bounced back and forth by these paddles.

Games comprised entirely of text commands were popular as well. William Crowther began developing a game that he created for his two daughters so as to bring himself closer to them once again. The program was based on maps he had created of nearby caves. His game was inspired by a Dungeons and Dragons fantasy role-playing game he played called *The Mirkwood Tales* (featured in the exhibit) created by Eric Roberts. Crowther added a few elements to the game, giving it a slight fantasy theme, and dubbed it *Colossal Cave*. His daughters enjoyed it and gradually the program was spread to other machines over the internet. In 1976, Don Woods came across this program and decided to contact Crowther to see if he could expand the program further. With the original author’s consent, he added a distinct *Lord of the Rings* theme to the game, incorporating touches such as a troll, elves, even a volcano inspired by Mount Doom in the trilogy (Adams, 2005). It was around this time that the game was renamed *Adventure*, which stuck with the game throughout the rest of its life. A small blurb from the game is written below.

Somewhere nearby is Colossal Cave, where others have found fortunes in treasure and gold, though it is rumored that some who enter are never seen again. Magic is said to work in the cave. I will be your eyes and hands. Direct me with commands of 1 or 2 words. I should warn you that I look at only the first five

letters of each word, so you'll have to enter "northeast" as "ne" to distinguish it from "north".

This simple introduction begins the game *Adventure*. It is unknown whether this is the original text by Crowther or from a different version created (Jerz, 2, 2001).

However, it is known is that the game began at a building near the cave. With various text prompts giving details of the player's location or of events that happen, decisions must be made by the player and the game becomes an intricate maze based off of those decisions. Woods' work pops up often in the form of a barrier that the player must cross to continue; for example, a troll who will attempt to kill you if you don't kill him first (Adams, 2, 2005).

This simple start opened up a world of possibility for beginning programmers excited at the sight of a game that had an expandable plot as this one did. From its humble beginnings, the game quickly became the "most famous, most modified, most ported, and most pirated game in the history of Interactive Fiction" (O'Brien, 7, 1999). Many different authors took the original layout for the game and added new rooms, items, and puzzles. An interesting standardization in naming came about for these games; as the game was made more complex, it would be commonly renamed by the new potential number of points that can be scored. Some spinoffs didn't even contain a similar plotline, such as John Laird's *Haunt* built in 1979, but provided a style inspired by *Adventure*.

The first significant spinoff of *Adventure* was a game produced in 1977 by MIT students Dave Lebling and Marc Blank, known as *Zork*. This game, written for the PDP-10, provided a similar feel to the original *Adventure* game but was actually completely rebuilt from the ground up (Persson and Meier, 1, 2005). The name was actually simply

a common name given to any unfinished prototype at MIT, but even with a proper renaming to *Dungeon*, the name *Zork* still stuck. Two years later, they marketed the game with the help of then-named Personal Software (later known as Visicorp). Many other versions made it to commercial sales, and in 1978 even *Adventure* itself was ported to the Atari VCS.

Along the same time, producers recognized the potential for video gaming as a marketing spin-off to already popular media, such as television shows or movies. With its popularity increasing, video gaming opened a world of resources and possibilities to promote such current media. One example, included in our exhibit, is the *Star Trek* series. By 1976 video gaming was becoming a regular pastime, and games based on the series were released.

The start of the 1980s marked the video gaming industry's second decade. The Atari VCS console was introduced in the 1970s, but sales were about to soar again due to the increasing popularity of video games (Demaria, 56, 2004). Home computer usage drastically increased during this decade, which attracted game developers to take advantage of these platforms. The 1980s is arguably the most innovative era, since developers could implement in-depth storylines, and cutting edge graphics into their games. There seemed like there was no turning back for the video games industry.

The Apple II computer was released in 1977 which resulted in independent developers using these machines to develop video games (Bellis, 2005). VisiCalc for the Apple II and soon thereafter, Lotus 1-2-3 on the IBM PC helped legitimize personal computers and increase sales. In turn, this meant many more potential customers for these games. Commodore and Amiga made a valiant attempt at being a force in the

Home PC market with the release of the VIC-20, Commodore, and Amiga PCs, but IBM and Apple had a firm grip on this industry. Most of the games developed during this era were made for these systems.

Text-parsing games continued to be extremely popular heading into the early 1980s. These games allowed the player to become immersed in the game environment by reading the text pushed onto the screen. Players would be able to react to what is happening, and then type commands to manipulate the characters and game environment. Most of these games were adventures, which were dominated by exploration, puzzle solving, and interaction with the main characters. Compared to previous arcade games, these games focus on storyline and plot instead of mindlessly testing reflexes.

One popular text-parsing computer game included in the museum exhibit is *Zork*. This game was officially released in 1980 by Blank & Liebling, and published by Infocom. It was the first commercially released text-parsing adventure games ever released for the computer (first released on the TRS-80), and was the direct successor to the mainframe game *Adventure*. The premise of the game is that you are a fearless adventurer who has been inspired by stories of the legendary realm of Quendor (also known as the Great Underground Empire). The empire was one of the mightiest in the world, but collapsed a few decades ago and the caverns lie empty (Wong, 2001). The objective of the game was to collect all of the nineteen treasures and place them in the house's trophy case. The plot for this adventure game was very straightforward, but enabled the players to be immersed into the gaming world. Numerous sequels to *Zork* were released throughout the 1980s and 1990s to continue the epic adventure. Most notably, *Zork III* was released in 1984, and is also incorporated into the museum exhibit.

Ken and Roberta Williams released their first game *Mystery House* in 1980. The married couple developed the computer game in their home office, which happened to be the kitchen (Demaria, 134, 2004). The company at the time was known as On-Line systems, but later changed its name to Sierra On-Line. *Mystery House* was the first adventure based text parsing game which also combined graphics for the Apple II (It was later released on the PC). Some of the graphics for the game are shown in Figure H1. Before this game was released, text based adventure games like *Zork* and *Adventure* were the norm. This was the first commercial computer game that contained real graphics. The game sold eighty thousand copies, which allowed the couple to produce three more games in 1980, and seven more in 1981 (Demaria, 134, 2004). The objective of the game is to simply go into the “mystery house” and to steal the jewels that are hidden within. The game itself did not innovate much on the storytelling side, but it led to the development of extremely popular *Kings Quest*, *Space Quest*, and *Police Quest* series of games released by Sierra On-Line (Demaria, 134-138, 2004).



Figure H1
A Screenshot from Sierra Online’s *Mystery House* (Mystery House, 2003). This is one of the early text-parsing graphical adventures.

There were other developers who made text-parsing adventure games as well. Scott Adams is an icon in the industry and founded Adventure International in 1978.

Throughout the late 70s and early 80s, twelve games were released by the company including *Adventureland*, *Pirate Adventure*, and *Secret Mission* (Adventure International, 2005). One game that is included in the exhibition is *Savage Island (Part 1 & 2)* which was released in 1982. The player starts the adventure on the beach of an island, and the objective is to solve a mystery of a hidden bottle of rum that is found on the beach. This game also combines text-parsing and graphics to make it immersive for the player.

Akalabeth was released in 1980 for the Apple II. It is another combined text-parsing and graphical adventure game. It was developed by Richard Garriott, and published by California Pacific. The plot of the game is to traverse the land of Akalabeth, and defeat the monsters as ordered by Lord British (Demaria, 118, 2004). Unlike most Role-playing games where the objective is to remove some-all powerful evil, the player is questing towards self improvement to become an Avatar (Schultz, 2000). The player's goal is to learn the eight virtues of the Avatar to understand how they are derived from Truth, Love and Courage. Even though only thirty thousand copies of the game were sold, it led to the creation of the highly popular Ultima series. Both *Ultima I* and *Ultima IV: The Quest of the Avatar* are featured in the exhibit.

The *Temple of Apshai* is a popular role-playing game originally released by Epyx in 1980 for the Apple II computer. In this game, the player's goal is to seek treasure in a dungeon while defeating the monsters that lie within (Temple of Apshai, 2005). The storyline for this game is minimal, but is still extremely immersive due to the combination of text and graphics to describe the rooms and artifacts in the game. Pen and paper Role-playing games were extremely popular during the early 1980s, which translated into success for this computer game. There were several add-ons released,

including the *Upper Reaches of Apshai*, which is featured in the museum exhibit, and the *Temple of Apshai: Curse of Ra*. A copy of the original game was not found, but the expansion pack was readily available. The Role-playing game genre is extremely important in the history of storytelling in video games, which makes it imperative to have in the exhibition. Role-playing games were

The early 1980s brought on many arcade game classics. Even though these games did not contain the most in depth and sophisticated methods for telling story, they did help evolve the gaming industry. Many of the games contained high quality graphics, and sound to immerse the player in the game. The most popular games also had addictive, and action packed gameplay.

The first smash hit game released that reached the mainstream in the 1980s was *Pac-Man*, released by Namco. The idea for this game came from the Japanese Programmer, Toru Iwatani, when he was staring at a pizza and noticed that there was one slice missing. Quite possibly, “It may have been the first and only time a game concept was inspired by an Italian entrée” (Demaria, 62, 2004). The storyline for this game was very simple; the main character, Pac-Man, was a hungry character whose goal was to eat little dots on the screen, and had to dodge his enemies within a maze.

Pac-Man's true significance is that there had never been a “real character” in a video game up until this time. In all of the previous game environments, games featured “nameless cars, spaceships, and featureless stick figures” (Demaria, 62, 2004). Pac-Man was the first true video game superstar, and joined the ranks of pop icons such as Mickey Mouse and Bugs Bunny. *Pac-Man*'s success spawned the “first real licensing craze with toys, lunchboxes, Pac-Man cereal, popular songs, and even a Saturday morning cartoon

show”. There were well over a dozen sequels made, including *Ms. Pac-Man*, *Professor Pac-Man*, *Pac-Man 2*, and *Baby Pac-Man* (Demaria, 62, 2004).

Another Arcade video game that had massive sales and a huge impact on the industry is *Defender*, developed by Eugene Jarvis and produced by Williams. The objective of the game was as follows; “Your mission, as a captain of the Defender, is to protect the humanoids stranded on the planet from their alien abductors” (Coin-Op Museum, 2005). As true with most arcade games up to this point in time, the storyline is not very sophisticated. There game did not feature any cut scenes, and didn’t immerse the player in the game world. The real breakthrough with this arcade game is that it is the first game to incorporate a virtual world. Radar is used to alert the player where the enemies are located (Demaria, 61, 2004). At a trade show in Chicago, Illinois, the game was deemed a flop because of the high level of difficulty (Coin-Op Museum, 2005). Contrary to the predictions, it became the highest grossing video game of all time, alongside with *Pac-Man*. Both of these games have earned more than one-billion dollars each (Coin-Op Museum, 2005).

Nintendo’s *Donkey Kong* was released in 1981, and is featured in the History of Storytelling exhibit. The game “is about a gorilla that runs away from his master, a carpenter, and steals the carpenter’s girlfriend. The carpenter must chase the gorilla through a series of industrial settings to rescue the girl” (Demaria, 82, 2004). This video game introduced the “save the princess” theme that is used in many later games, including those designed by Shigeru Miyamoto. The game is in the exhibit is because of its highly innovative plot which paved the way for future games in this genre.

Activision released the highly innovative game *Pitfall* in 1982. To continue the trend with most of the games made during the 1980s, the plot is very basic. The main character, Harry, must run around through the jungles and collect all of the treasures that were hidden in Enarc (Brundage, 2005). The game definitely did not make any breakthroughs in regards to storytelling, but *Pitfall* is the first game with a side scrolling environment (PS3 Portal, 2003). A screenshot showing the side-scrolling environment is in figure H2. This style of game allows the player to control the main character in a 2-Dimensional environment. In most side scrolling games, the player has to run, jump and sometimes duck to avoid obstacles, and fight through many enemies in order to reach the goal. *Pitfall* laid the groundwork for future side scrolling games, including the popular *Super Mario Brothers* and *Lode Runner* games.

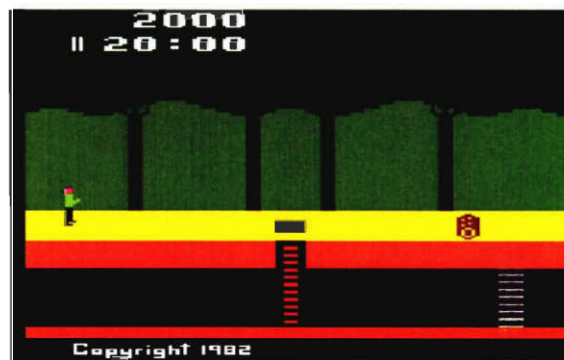

Figure H2

This is a screenshot of the side-scrolling environment in Activision's *Pitfall* (Brundage, 2005).

Another game featured in the exhibit is *Castle Wolfenstein*, by Muse Software. The game was not a huge technological breakthrough, but the gameplay was very intense and exciting. The objective is for you (the prisoner) to escape from the castle while avoiding or killing any of the Nazi guards (Castle Wolfenstein, 2005). This game offered an overhead view of the action, which paled in comparison to the 2-D side scrolling games offered in arcades and console games. This was the first game to implement

sampled speech in a computer game. ID software purchased the rights to the game and created highly successful sequels in the 1990s (Castle Wolfenstein, 2005).

Even though the 1980s introduced many new games to the market, this era also endured the biggest flops and failures in the industry. The biggest single video game flop in history is Atari's *E.T. The Extra Terrestrial* (PBS, 2005). This video game was designed, programmed and debugged in six weeks. Immediately after the development cycle, over five million copies of this video game were produced for the Atari 2600, which exceeded the number of systems available at the time. The vast majority of these game cartridges were unsold, which resulted in Atari sending the extra copies to the landfill (PBS, 2005).

The big video games industry crash started late in 1983. Numerous companies went bankrupt, but this turned out to be more of a shakeout than a crash (1983 crash, 2004). With the combination of the already poor economy, the quality of games rapidly declined, the overly aggressive and expensive marketing practices by the game developers, and low sales caused the crash. During this time, critics argued that video games were overexposed. "Every company in existence had decided that they could make money in the video game marketplace" (1983 Crash, 2004). Companies including Kool Aid and Chuck Wagon dog food had contracted developers to make video games to help promote their products. Even Quaker Oats had their own video game division during this time. The industry simply had not matured enough at this time to enter the mainstream market. The games did not appeal to the mass market, which caused so many of these companies to go bankrupt.

Another reason why the industry spiraled downwards is because of the success of many classic games including *Pong*. Numerous video game manufacturers released “almost identical games, which left the customers unable to differentiate between them” (1983 Crash, 2005). This all resulted in the massive shakeout of the industry, forcing companies such as Mattel, Magnavox, and Coleco to abandon the industry all together. In 1982, the revenues for the entire game industry exceeded three billion dollars. By stark contrast, the revenues in 1985 were a pitiful one hundred million dollars (Thomas, 2003). The video games industry was virtually dead in the United States.

Despite the massive downturn, the video games crash had a positive effect on the industry. The shakeout forced developers to create new, original, and high quality games. The release of the Nintendo Entertainment System (NES) in 1986 turned the industry back the right direction (PBS, 2005). *Super Mario Brothers* was released for the NES, and this saved the video games industry. The game is a milestone in the video games industry, is on display in the exhibition, and can be played in the interactive room. The game successfully combined the “save the princess” theme which made *Donkey Kong* very popular, along with the side scrolling environment that *Pitfall* first created. As with any “save the princess” theme based game, the plot was very simple; Mario and his brother Luigi had to rescue Princess Toadstool from the grasp of the evil Bowser Koopa (Demaria, 236, 2004). When the game is started, the player is immediately placed in the game world. The only explanation of the plot is in the manual that was included with the game. The game’s state of the art graphics and gameplay makes it a timeless classic. Figure H3 below shows the brilliant graphics that were incorporated into the game. It

spawned dozens of sequels (with many more to come), a cartoon, a movie, and many merchandise product lines.



Figure H3
Screenshot of Nintendo's Super Mario Brothers, which saved the video games industry. (Gamekult, 2000)

Another monumental game released for the NES in 1986 is *The Legend of Zelda*. This game is also featured in the exhibition, and in the interactive room due to its popularity, and innovative storytelling. This game followed a much more complex version of the highly successful “save the princess” theme, and became a smash hit. In the land of Hyrule, there was a princess named Zelda. An evil being named Ganon came to Hyrule in search of the Triforce, which is a legendary golden triangle that granted mystical powers to the beholder (Legend of Zelda FAQ, 2004). Ganon managed to find the Triforce of Power piece, which made him a force to be reckoned with. His next goal was to find the second piece, called the Triforce of Wisdom. He knew that Princess Zelda possessed this Triforce, so he went after her. Zelda managed to split the Triforce of Wisdom into eight shards, and hide these in elaborate underground dungeons scattered throughout the land. Ganon did manage to capture Zelda, but she sent out her bodyguard

Impa for help. Ganon and his troops were able to corner Impa in the middle of the wilderness. The young hunter named Link showed up at the right place at the right time. He was able to fend off Ganon and his minions. Once the enemies were gone, Impa told Link the entire story, and then he vowed to be the hero and save Princess Zelda and the land of Hyrule (Legend of Zelda FAQ, 2004). Link's quest was to find all of the eight shards of the Triforce of Wisdom hidden throughout the dungeons. Once he became powerful enough to enter Ganon's lair, he would have to slay him, rescue the princess and save Hyrule from the madness. Compared to all the other games released at the time, *The Legend of Zelda* had a very in depth and enticing storyline. It is often considered as one of the great adventure gaming classics. On the technological side, it was the first console game to incorporate a save game feature, and had a very original style of gameplay. The save game feature allowed players to experience the game at their own pace. This allowed players to play for as long as they pleased, and return at the exact same state at a later time. The implementation of this feature allowed developers to make longer and more immersive games which had a long continuous storyline. Up until this game, most games were 2-D side-scrollers. *The Legend of Zelda* featured an overhead view to give the players a better view of the action. Even though the game was not a true RPG, it is often considered a founding father for the genre. Even though RPGs such as the *Zork* and *Ultima* were developed in the past, they didn't hit the mass market until the late 1980s and early 90s. Many sequels spawned from this original game, including *Zelda II: The Adventure of Link* also for the NES, and many other versions for future consoles developed by Nintendo Incorporated.

Also during the same year, Electronic Arts released the popular *Starflight* computer game. In this game, the player took on the role as a captain in a state of the art starship, which was created to rescue a “dying homeworld in a seemingly barren galaxy” (Starflight, 2005). The game allowed the player to explore hundreds of planets throughout the galaxy. The plot for this game was seemingly one dimensional and linear at first, but it turns out to be quite a “space opera of epic proportions containing shocking plot twists and deep mysteries” (Starflight, 2005). This game is most widely known amongst the industry as pioneering open-ended gameplay.

In late 1987, the smash hit *Mega Man* was first released for the Nintendo Entertainment System. This is another classic side scrolling game (Mega Man Game FAQ). In this game, Dr. Light “has created nine new robots made to help in production and maintenance of Megaopolis, a major city where humans and robots alike live together in harmony with each other” (Kishan, 2001). Dr. Light’s assistant, Dr. Wily, however stole six of the robots from the lab and reworked them to plan on taking over the city, and the entire world. The remaining three robots, Mega Man, Proto Man, and Roll must work together to stop Dr. Wily before it is too late (Kishan, 2001). Once again, the plot for the game is very simple as common with most of the games produced in the 1980s. Unlike most games released at the time, *Mega Man* allowed the player to beat the game in a non-linear fashion. Before entering a level, the player has a choice of which world and boss to defeat before encountering the next one. After each boss robot is destroyed, Mega Man is given a new weapon. The strategy involved in choosing which boss to attack first is very important if the player wants to have the easiest time beating the game. This game spawned a slew of sequels up to the present day.

1989 marked the release date for the extremely popular PC game *Populous*, designed by Peter Molyneux of the Bullfrog development studio. In this game, the player's goal was to shape the landscape and build a civilization with the goal of conquering the enemy force. The game is regarded as the inaugural god game. In this type of game, the player has complete control of the lives of virtual people or worlds (Populous, 2005). *Populous* spawned numerous sequels, and many other god games released in the 1990s and beyond.

In the early 1990s, the video gaming industry adopted a new style of storytelling. Instead of inventing new plots to match developing games, designers imported popular stories from outside the gaming world. One game that is featured in the exhibit and followed this trend is *DragonStrike*, released in 1990. *DragonStrike's* storyline was taken from the popular DragonLance universe, which is a realm of Dungeons and Dragons. The DragonLance universe was so popular that they bought the new *DragonStrike* game on the sole basis that it expanded upon the original storyline. This new idea of bringing in customers with popular story rather than just video and gameplay would soon expand exponentially. Instead of making games with new stories, developers could just expand on the old ones. This effectively created massive worlds which brought games back for more.

On display in our exhibit because of its fine storyline reuse was the biggest selling stand alone video game of its time, *Super Mario Brothers 3 (SMB3)* for the NES. In the aftermath of an incredibly profitable use of *SMB3* in the movie "The Wizard," the game gained a major hype while Universal Studios paid Nintendo for the use of Mario and other characters. With the free promotional movie, *SMB3* was so popular when it was

released that it brought in more money than anything else in the entertainment market for three years, until the movie E.T. became a huge hit. *SMB3* grossed over 500 million dollars alone and by the end of its production it sold 17 million copies. *SMB3* permanently placed Mario in the spotlight. The game furthered the plot of Mario by placing Mario on a quest to free his princess from various Koopa bosses, but always being in the wrong kingdom. “*Super Mario Brothers 3* brought the action back to the Mushroom Kingdom, which was now a fully realized place” (Davis, 1, 2005). It was this game that secured the Mario series and allowed it to expand and add multiple characters. Many of these characters were featured in future games produced by Nintendo. In the present day, Mario is easily the most well known story in video gaming history.

‘Like with Mario, storyline expansion did not have to come from an outside source (such as DragonStrike or Star Wars). Some games started their own storyline worlds and survived long enough to create a fan base. With a following, a saga of games could follow. One such following from 1990 was *Wing Commander* by Origin Systems. Set in the 27th century, *Wing Commander* was about a young Confederate Navy Lieutenant. His goal was to take control of the Vega Sector in space ruled by the Kiltrathi, an alien race focused on ruling the galaxy. The game was designed to be a space flight combat simulator which focused more on great gameplay than real world physics. Despite its impressive development cycle, people were so pleased with past games and their storylines that they were willing to purchase *Wing Commander* blindly. Even so, it lived up to its predecessors and expanded even more on storytelling in general. The game’s character development, interpersonal conflict, and ethics make it significant in storytelling history (Biondich, 1, 2005). After each mission, a part of the story was

revealed to the player. Occasionally the player could make a major plot splitting decision that changed the story and ultimately affects the overall outcome of the game. Although the first two *Wing Commander* games used cartoon cinematics, *Wing Commander* started a series of games that were of the earliest to play out like a movie with cut scenes that used real actors. In figure H4, a screenshot from a cinematic sequence in *Wing Commander 3* is shown.



Figure H4
Comodore Geoffrey Tolywn Malcolm McDowell from *Wing Commander 3* looking up from a star map.

As time moved on in the game development world, developers exhausted story reuse. Gamers begin to demand more from their games than just a familiar setting and characters. Technology and gameplay soon stepped back into the light. With more space and speed available from the new Super Nintendo, Nintendo released *Super Mario World* in 1991, which is on display in our exhibit. The game world was 3 times the size of previous Mario games and it sported colorful graphics and animations. It introduced the addition of a new character, Yoshi, who would later go on to spawn another series of games. Being yet another major Mario success, *Super Mario World* began the trend of

character creation from Mario games. Later Wario, WaLuigi, and others would emerge from the wildly popular series.

Watching Nintendo win over players with Mario, Sega decided that if their company was going to succeed they would need a popular mascot for their 16-bit system, Sega Genesis. “Add a face that looks eerily like Felix The Cat, a good dose of attitude, and enough energy in his system to equal one hundred caffeine addicts, and you have Sonic The Hedgehog,” (Davis and Shoemaker, 1, 2005). In 1991 the release of *Sonic the Hedgehog* worked out far better than Sega had even hoped for. The character and game were completely designed to take advantage of the Genesis’ advantage over Nintendo: speed. To match this theme, they designed Sonic and the storyline of the game. Sonic would be kept simple with only the ability to jump and run. His goal was to defeat evil Dr.Kintobor who had turned every animal on the planet into robots, excluding Sonic because he was too fast to be caught. To win, Sonic had to run through the game using his speedy jump spin attack to defeat his enemies. This was one of the first times the story of a game was designed specifically to highlight the latest technology. This later would be seen again in games when graphics cards were introduced.

Sonic was one of the games that would bring about another turning point in video games. Once again they would return to their root, featuring technology changes in video in sound rather than rich storyline. Very few games have had as big an impact in this way as *Wolfenstein 3D*, released 1992 by id Software.

Wolfenstein 3D’s story was about the ally member Captain William J. Blazkowicz, his gun, and the eight floors of Nazis he had to kill to escape a Nazi dungeon (Bowen, 1, 2005). The game’s major significance was that it introduced the first-person

shooter (FPS) to the mass market. Instead of the traditional side-scrollers or even a top down view, *Wolfenstein* presented the Nazi dungeon from the Captain William's perspective. The player saw what the character saw projected three dimensions onto the screen, as shown in figure H5. At the time three dimensional games required immense processing power and *Wolfenstein* was no exception. It was made possible only by the vast advances in computer technology of the time. *Wolfenstein* was certainly not the first FPS but it took advantage of the latest technology combined it with excellent sound and visceral action, made it a smash hit.



Figure H5
A screenshot of the first person view in *Wolfenstein 3D*

Wolfenstein opened the door for a revolution of first person shooters and at first this was a massive blow to storytelling in gaming. “Part of *Wolf3D*'s appeal is in its simplicity: it is all about firepower, not brainpower,” (Bowen, 1, 2005). First person shooters took the gaming community away from story and brought them closer to action. Many years later, games like *Duke Nukem* and *Halo* would progressively expand the genre into a story telling form of entertainment but for a while it only mattered how much more convincing the developers could make the gore. *Wolfenstein* not only gave birth to a new genre, its repercussions changed the game industry forever.

What came next in the history of storytelling was general experimentation. In our exhibit we feature artifacts from games like *Maniac Mansion*, *King's Quest*, and *Monkey Island* because they tinkered with old storytelling methods to great success. For instance, *Maniac Mansion* came from the original command line style RPG. Instead of one character typing in commands like “open cupboard” and guessing which verb and spelling would make it work, there were multiple characters you controlled and the keyboard was completely removed from the game. You used the cursor to pick from a table of verbs and then clicked on the object you wanted to perform the verb on. This kind of experimentation in game design made games of that type less about guessing and more about deductive reasoning and figuring out the story.

Another example of such experimentation came in 1992. Accolade, a publisher well known for sports games, released its very unique epic sci-fi space shooter role-playing game, *Star Control II*. Listed as one of the best and most unique epic games of its type it was one of few successful attempts at merging different game types (Kasavin, *Star Control II*, 1, 2005). It had a top down combat view, an unbelievably good storyline for its time, and some well integrated RPG elements.

*The game begins when you return to Earth after being marooned for decades on a distant planet, only to find that the human race has been enslaved by a hostile caterpillar-like race called the Ur-Quan. Separated from your species, your only hope is to try to free Earth and put an end to the Ur-Quan conflict. In so doing, you travel across the galaxy, upgrade your alien vessel from a skeletal husk into the most powerful starship around, recruit the assistance of a number of memorable alien races, and do battle against many others (Kasavin, *Star Control II*, 2005).*

Simply put, *Star Control II* is worthy of mention because it made you feel like you were in the story. The player was free to continue the plot, build an army, become rich, or explore the universe. By the end you could choose to tie all loose ends or leave

things unfinished, there was no higher authority giving you missions or orders, you were in control. Even while conversing with aliens, as shown in figure H6, the player had the option of choosing what to reply with, effectively making friends or enemies depending on the choice. The game pushed the envelope for creating a detailed universe that players could lose themselves in and because part of the story. This rare hybrid inspired more in-depth worlds in future games but was so original that it has not been imitated in the more than ten years since it has been released.



Figure H6
During conversation in *Star Control II*, you usually had some interesting responses you could choose from.

X-Wing, the first big Star Wars PC game, is well known in history but its successor *TIE Fighter* is one of the most impressive PC games of the mid-nineties. Lucas Art's *TIE Fighter* (released 1994 and shown in the exhibit) featured one of the most in-depth storylines for its time. Each mission had a primary, secondary, and secret goal. Players could just satisfy the primary goal to continue on, but if they were dedicated enough they could finish the secondary and secret goals to unlock hidden pieces of the plot line. The game also placed the player in the Galactic Empire, the well known bad guy of the Star Wars universe. Unlike other games of its time, *TIE Fighter* did not have a

player self-moral realization to turn into a good guy; it kept the player with the Empire all the way to the end – an unheard of idea at the time. Combining story from the movie and novels by Timothy Zahn, *TIE Fighter* had one of the most enriched plots of any game of its time (Chin and Kasavin, 1, 2005).

In the mid-nineties, as always in video games, things started to change again. Previously games always had a single protagonist. But in the coming years, games would have players tell stories through multiple characters.

While neither game invented the Real Time Strategy (RTS), *Warcraft II* and *Command & Conquer* both brought RTS into the mainstream in 1995 (Bush, 2, 2005). More than a chess game, RTS allowed the control of multiple units. Instead of being one person with a life bar, you controlled an army and built cities and conquered your enemies. Both *Warcraft II* and *Command & Conquer* showed a long spanning plot that put the player in very different situations each mission. Some missions involved all out war while others required the escort of single units. Both games incorporated stunning and slick cut scenes that outlined the progression of the story. Real Time Strategy would become very central in the coming years with games representing entire eras and wars. With RTS, stories could be told on a much large scale than the story of a single person.

In game history, there are no clear cut defined eras of storyline types. This is because while some developers abandoned some styles, others went back to them. The lines are blurred and you can find different styles mixed together constantly. Here are some games that went against the times, but never the less had a unique impact on storytelling in games.

Telling a story through pictures, the PC game *Myst* was a very important puzzle game from 1995. Some avid gamers would go as far as to classify games as before and after *Myst*. *Myst* certainly did have a big effect on gaming. It was one of the first story driven games that had no death and no dialogue (Sengstack, 1, 2005). Outside of brief cinematics, you rarely saw anyone else. The game is set in a bright yet isolated world without people. You are alone until you find a book with a person looking back at you from one of the pages. *Myst* featured incredible art and challenging puzzles of logic. Combined with its in-depth storyline, it was a huge game (made possible only by the massive storage ability of the CD-ROM) and it only had two brothers for developers! *Myst* showed a new form of story telling that didn't feed the player the plot so easily; they were forced to figure things out.

Another game that stood out during the mid nineties was *Resident Evil* in 1996. *Resident Evil* was a third person shooter with a major focus on horror. Before this game, no other game had really made its entire theme solely survival horror. With a rich storyline based on survival and betrayal, *Resident Evil* defined the survival horror genre in gaming and completely immersed the player in a story where they felt like they were in a horror film. Despite its horror predecessors, no other game brought this genre into the mainstream as much as *Resident Evil*.

Lucas Art's released what many argue to be the finest graphics adventure creation of its time, 1995's *Full Throttle* (Young, 2005). The superb story is of a confident square-jawed man named Ben waking up in a dumpster framed for a crime he didn't commit. The film-quality plot contains murder, deception, greed, lust, love, and honor – all with

good balance. The game, on display in our exhibit, perfected the art of story telling in adventure games and is remembered for that fact ten years later today.

Up until the late nineties, games had always been the ones to tell the stories. This changed when games started becoming vessels for players to tell stories instead.

In 1997 one major game genre still had yet to emerge into the mainstream. That genre was MMORPG, or Massively Multiplayer Online Role-playing game. The MMORPG was fathered by Origin System's *Ultima Online*. In this online virtual world people could live out their characters' lives with other real players through the use of the internet. While the developers constantly added more content to the game through the internet, the true story of the game was open ended and defined by other human players. In fact, players would write news stories on the happenings of other human players in the game world. In a lot of ways MMORPGs pulled people away from actual storytelling and brought them closer to story creation, but later on some MMORPGs would become more in depth and driven such as *Everquest* and *World of Warcraft*. MMORPGs were and are notoriously difficult to develop story for because multiple players must be able to play out the plot on their own all in the same world. If you save the princess, will she be there for the next hero to save? In a way all players had to take a step down from being heroes and were more like equals.

At the end of the nineties, many games were released that were not changes in the general field, but made impacts in their own genres regarding storyline. Here are some highlights that are well remembered for paving the way for current storytelling.

The Legend of Zelda: Ocarina of Time for the Nintendo 64 was a landmark title in terms of storytelling through videogames. "The new benchmark for interactive

entertainment has arrived”(Schneider,1,1998). The story of Zelda has been seen in some form on every Nintendo console; but this game was the first to bring Link and his adventures into three dimensions (see Figure H7). However, this was not the only significant thing about this game. The game featured one of the largest game worlds in an action/adventure game up to that point, as well as an intricate plot and clever story progression. Specifically, the game world was touted as the most interactive world in a game up to that point, a world in which if the player could see an area anywhere in the distance, they could more than likely go there. This level of unbounded game world design would set the bar higher than it had ever been before, and coupled with the games stunning visuals left the player immersed in the games story (Gerstmann, 1, 1998).



Figure H7

When the first screen shots similar to these hit *Gamespot.com* before the game’s release, the site experienced more hits in one day than it had ever before (Gerstman, Screen Shots, 1998).

The story of Metal Gear was first seen on the MSX home computer and more notably later, in the form of two games *Metal Gear* and *Metal Gear 2* on the NES, however in 1998 a next generation sequel, *Metal Gear Solid* (MGS) was released on the Sony Playstation. Several video features discussing the history of the game series are included in the interactive media section. “What can I say? Hideo Kojima has come through and produced the finest PlayStation game ever” (Nelson, 1, 1998). In *MGS*, you

play as special operative Solid Snake as you are suddenly launched into a mission that turns from a simple hostage rescue, into saving the world from nuclear holocaust. The game is presented as a stealth/action game, in which the importance of being undetected far surpasses a traditional “guns blazing” approach. In designing the game as such, the creators perfected this genre and brought it to the forefront of gaming, resulting in several other hugely successful games such as *Splinter Cell* and its subsequent sequels. This title marked a significant change in how in game FMV sequences would there after be used in games. It displayed very strong cinematic qualities, both in design and implementation, something that had been seen in a handful of earlier games. However this game perfected it. The fact that it was developed at a time when computer graphics technology were beginning to make large advances, its transitions between gameplay and in game cut scenes were seamless (Nelson, 1, 1998)(Perry, “Metal Gear Solid”, 1, 2005). “Fact -- the game enables players to immediately immerse themselves into a movie-like game that stirs a fantastic cocktail of high-quality, informative cut-scenes in an unobtrusive fashion in amongst smart stealth-based gameplay”(Perry, “Metal Gear Solid”, 1, 1998).

1998 also saw the arrival of another very significant action game for the PC, *Half Life*. The exhibition features a copy of the actual game software for this ground breaking title as well as gameplay footage in the interactive media section. In this game, you play as Gordon Freeman, a scientist in a mysterious research facility. When something terrible goes wrong, you are released into a world where nothing is normal and you fight for survival. While the plot is not terribly original, the execution of the story was unparalleled at the time. “Through a series of subtle and artistic design decisions, *Half-Life* creates a reality that is self-contained, believable, and thoroughly engaging”(Dulin,

“Half-Life”, 1, 1998) *Half Life* unquestionably marked a change in the first person shooter genre in terms of gameplay elements; however it also made revolutionary changes to story. Unlike many other games before or since, the game opted to cut back on the use of FMV sequences, instead the game flowed seamlessly, playing out in real time. This meant that the player gained a sense of continuity and could become completely immersed in the plot and how it played out. In addition to this, the game was one of the first to heavily use scripted events during gameplay that would give it a more cinematic feel (Dulin, “Half-Life”, 1, 1998).

This year also marked the release of one of the best selling real time strategy games in history (over 6 million copies sold), *StarCraft* (“Blizzard Entertainment Press Release”, 2002). A Blizzard Product Catalog is featured in the exhibition, as the company has produced many games significant to the evolution of storytelling in games. In this game, you play as the commander of the armies of three distinct races in a futuristic setting. “It doesn’t stray far from the blueprint created by its predecessors, but it is without a doubt, the best game to ever adhere to that formula”(Dulin, “StarCraft”, 1, 1998). While it was not the first Real Time Strategy game to heavily incorporate elements of story into gameplay, it added new and innovative methods of expressing that story. The game featured the typical FMV sequences expected of such a game; however, it added pre/post mission briefings that strongly emphasized the introduction and evolution of characters (see Figure H8), as well as in game dialogue and scripted events. Each race had its own distinct characteristics, both artistically and technically, taking the game to a new level, as no previous game had gone to such lengths to distinguish each race. “The RTS genre was pretty well established with Blizzard’s *Warcraft* and

Westwood's *Dune II*, but it didn't change significantly until Starcraft came out in 1998, pioneering the concept of dramatically different races in one game”(Chick, 1, 2000).

This care in creating distinct races unquestionably added to the depth of the story as well as adding to the gameplay. Finally, the inclusion of persistent playable characters that interact with each other and the player added another layer of the story and further immersed the player.



Figure H8

This is an example of the pre/post mission briefing screen where a good deal of the character development took place (Dulin, “StarCraft”, 2005)

By 1999, internet access was standard to most computer users and internet gaming became increasingly popular. In the past, many games featured multiplayer as a secondary feature, and some games such as *Ultima Online* were focused in the online realm. However this year saw a vast increase in these types of games and marked the beginning of the Massively Multiplayer Online Role-playing game as a vastly popular genre. This meant more player to player interaction than ever, opening the door on infinite possibilities for story creation and development.

In 1999 one game expanded the Massively Multiplayer Online Role-playing game genre drastically, and that game was *EverQuest*. Screen shots from this landmark title will be featured in the exhibition. In *EverQuest*, you as the player take control of a fully customized character that you create from scratch. After that, you are allowed to essentially find and follow any story path that suits you within the game's universe. This game was by no means the first of its kind; however, it was the first to reach such a huge audience. With the internet progressively improving throughout the decade, and with broadband becoming more readily available, this game exploded onto the scene with its impressive design and graphics which were unmatched by any other MMORPG at the time. The game presents the player with a universe in which they can create their own characters and live out their own story dynamically. It uses a quest based system to develop gameplay, and each player can further enhance their character depending on what quests they chose to complete. These quests can sometimes intertwine with those of other players, as well and they do not always need to be violent in nature. In fact, the player is allowed to follow a non-violent path and still be successful in the game world. "Between its excellent graphics, its performance, its rich fantasy setting, and its propensity to force you to cooperate with, rather than hinder, your fellow players, *EverQuest* is the best game in its class"(Kasavin, "EverQuest", 1, 1999).

2000 was the year of *The Sims*, a game that is, in short, a simulation of life. The player selects and customizes family members, builds a house, and then interacts with the game as the virtual family's life carries on (see Figure H9). "The Sims, for all its frustrations, highs and lows, is still -- gulp -- better than your average working day in real life, and a fun experiment in psychology, love and relationships"(Lopez, 1, 2000).

Though there had been several “Sim” games previous to this one, *The Sims* was the first to introduce human behavior as the primary catalyst on such a specific level. The game lacks a predefined story; it has no preset beginning or end, and yet it still allows for the development of a story. Perhaps its massive popularity can be traced to the fact that this story that the player creates for their virtual family can be related to his/her own life story, something that other games can accomplish, but not on such a simplistic yet specific level (Lopze, 1,2000).



Figure H9
The game featured a very easy to use and intuitive menu system thus making it accessible to a very wide audience (Park,Screen Shots, 2000).

As 2001 rolled around, the videogame industry was changing, specifically in terms of artistic content and storytelling. Developers were finding more and more success in turning to darker storylines, based on characters that would traditionally be considered the antagonist. Though this marked evolution in what direction videogame storylines could be taken, it also caused a good deal of controversy, as this new trend in storytelling resulted in more realism and violence being presented to a wider audience.

“Having taken advantage of PS2's new technology to expand and develop their vision, the makers of *Grand Theft Auto 3* have created a complete videogame experience

like few, if any, before it”(Perry, “Grand Theft Auto 3 , 1, 2001). The *Grand Theft Auto* series is undoubtedly one of the most original and controversial ever. Video features on the history of the game series and the more recent iterations are included in the interactive media section. While the first two games in the series did a great deal in establishing it, the series did not really come into its own until the third installment, *Grand Theft Auto 3*. In it, you play as a no-name criminal, trying to work your way up the crime ladder of a New York inspired city. The game allows the player to either follow a specific storyline through a series of missions, or to simply explore what the city has to offer in their own way. This was a marked change in game design, where the game was created with enough content to keep a player satisfied even if they chose not to pursue the missions. While the earlier games in the series had followed this ideal, *GTA3* perfected it, by not only presenting it in a completely 3D form, but also by vastly expanding the game world and turning it into a living, breathing city (see Figure H10). Things like dynamic changes in what types of people are seen on the street according to the current time of day, dynamic weather changes, and moving traffic and public transportation all added to the game world immensely. Additionally, the game’s actual story was rich, featuring professional voice actors and a fully developed script. As well received as the game was, it still caused a great deal of controversy due to its violent content. Though the previous *GTA* games included similar content, this game was more realistic than ever before and was also introduced first on the PS2, a console that, unlike the PC, was much more accessible to a younger crowd (“Classic: IUP.com’s Essential 50 , 1, 2005). Despite this though, *GTA3* still will go down as an extremely significant title, it broke as many boundaries as it caused debates. The game was not only

technologically way ahead of its time, but it was a culmination of the idea that games could take on dark, realistic storylines and still be well received by gamers (Perry, “Grand Theft Auto 3”, 1, 2001).



Figure H10

These shots show the progression of the GTA series graphically. You can see that *GTA 3* (pictured to the far right) showed a marked improvement over the previous two games, further enhancing the sense of realism and story immersion within the game (Perry, “Grand Theft Auto 3”, Screen Shots, 2001).

Another notable game from this year is *Max Payne*. In this title, you play as Max Payne, an undercover cop, whose family and friend have just been murdered, leaving him in an intense mystery that leaves him framed for the crimes. The game’s original trailer is featured in the interactive media section of the exhibition. The game goes above and beyond what is expected of an action game in terms of storytelling. “The story elements are handled through a variety of means, presented through in-game cut scenes, conversations during gameplay, and narrated graphic novel-inspired panels that fit the game perfectly, and really add a lot of style and character to the game in the process” (Blevins, 1, 2001). The game did not revolutionize the industry in terms of storytelling, however it still deserves credit because it portrayed a dark story (something that was only beginning to become massively accepted), in a way that left the player compelled to continue on with the game.

With a story similar to that of *Max Payne* which had been released on the PC one year earlier, *Dead to Rights* left a significant mark on the console market in 2002 with its initial release on the X-Box. The game tells a story of a police officer named Jack Slate, who has been framed for murder. In this action style game, you as the player must take Jack through society's underworld to clear his name. While the game did not receive much recognition for its quality of gameplay, it was revered by many as having one of the best stories of the year and the execution of that story was extremely well done and reminiscent of an action movie. Though many earlier games had been using cut scenes and general film techniques to give them a more cinematic feel, this one was an excellent example of the state of the industry in this area. "Simply put, the game is an excellent example of how far storytelling in video games has come" (Bush and Cheung, Best Story, 2002).

This year 2002 also brought one of the most anticipated real time strategy games ever, *WarCraft III:Reign of Chaos*. This game was the sequel to Blizzard's *WarCraft II*, and essentially the next in line after 1998's *StarCraft*. The game carried on the story started in the original *WarCraft* games; however, it presented this story through modern technology that gave it new life. "*Warcraft III* has lots of great characters, and its fantasy-themed world has tons of personality" (Kasavin, "WarCraft III: Reign of Chaos", 1, 2002). In addition to a well thought out and designed story and universe, the execution of the story was advanced. Where Blizzard's previous RTS, *StarCraft* used extensive amounts of FMVs and mission briefings to convey its story, *WarCraft* cut down on this, instead opting to primarily use game engine rendered sequences that were interlaced within the action.

Star Wars Galaxies: An Empire Divided was one of two RPG games based on the Star Wars movie franchise to be released in 2003. The game software is featured in the exhibition as well as several video clips that can be found in the interactive media section. This game was the first MMORPG based on Star Wars, and the first based on any major movie franchise. The Star Wars galaxy is arguably one of the richest fictional worlds in existence, and this game fully took advantage of that fact, allowing a variety of character types and storyline possibilities. This game did even more than *EverQuest* to make MMORPGs more accessible to the general population due to the fact that Star Wars is massively popular and recognized. Though the start of the game was somewhat rocky, it evolved nicely, and currently also offers an expansion based on space flight called *Jump to Light Speed* (Kasavin, “Star Wars Galaxies: An Empire Divided”, 1, 2003)

The second notable Star Wars related game of 2003 was *Star Wars: Knights of the Old Republic*. The interactive media section features several developer interviews focusing on some of the many development stages of the game. Developed by the same folks who were responsible for *Baldur’s Gate*, this was also an RPG; however it was a single player RPG unlike *Galaxies*. The thing that made *KOTOR* unique was that it firstly took all the elements that made *Baldur’s Gate* a great game and applied them to a game set in the Star Wars universe, but more importantly, while it took place in the Star Wars universe it did not feature any of the characters from the original films. In fact, the game’s story takes place thousands of years before the events of the films. This meant that the developers had to create a completely new set of characters and other environmental aspects while staying true to the franchise’s settings and overall feel. Typically, Star Wars games tend to intentionally stray somewhat from the films, but run

in parallel with the storylines of the films. This game followed a completely unique and original storyline. “*Star Wars: Knights of the Old Republic* is not only providing one of the very best interactive Star Wars experiences, but it has tapped into the very soul of the Star Wars universe that drew hundreds of millions of fans to the franchise in the first place” (Boulding, 1, 2003). The game is very immersive, allowing the player to play as and interact with characters that have similar qualities to those found in the films. The game presents its story brilliantly through an intuitive interface, countless cut scenes and hours of dialogue, so the game universe and the characters found in it are amazingly convincing. At the time of the game’s release, some even argued that the plot was better than the two Star Wars prequels, as it encompassed more of the elements of the original Star Wars that made the films so appealing to the masses. This once again solidified the idea that a game could have a storyline as compelling as or even more compelling than a film (Kasavin, “Star Wars: Knights of the Old Republic”, 1, 2003).

Within the past year we have seen one Massively Multiplayer Online Role-playing games (MMORPG) that has been changing the genre: *World of Warcraft* (WOW), released by Blizzard Entertainment late in 2004. Similar to other games of its type, WOW is a virtual world and allows players to do whatever they want. Players choose their race and class and can go anywhere and do anything. In relation to story telling however, WOW makes a bigger leap than most games. Unlike other MMORPG’s of the years before it, WOW consists of over a thousand in-plot quests, all of which slowly unravel the story of the Warcraft universe. Evenly dispensed across pubs and inns are history books of *Warcraft* that players can read in-game. Combined with locations and heroes shown in previous Blizzard *Warcraft* titles, WOW makes MMORPG players

feel immersed in a game world like never before, writing themselves into the story as they play (Kasavin, “World of Warcraft”, 1, 2004).

Conclusions

The *Save the Princess: The History of Storytelling in Video Games* was a success. We learned about the storytelling video games between the 1970s all the way up to the present day. Our research has shown that the complexity of the storylines in video games has directly correlated with the evolution of microprocessor, sound, and graphics technology.

The research on museum exhibit curation was a success too. Visiting Boston's Museum of Science and the Worcester Art Museum allowed us to gather valuable information on setting up a museum exhibit. We learned that running a museum exhibit is a much more difficult task than it is at a first glance. The time and thought that must go into the label writing and exhibit design is much more complicated than we first expected. Designing the interactive room was also a challenge. We had to determine which games the visitors want to play, and which of the game titles would prove to be the most educational.

Once again, we would like to thank the Stanford University Libraries and the George C. Gordon Library at Worcester Polytechnic Institute for making this project possible. Stanford University allowed us to borrow artifacts from their own history of storytelling video games exhibit. Worcester Polytechnic Institute provided us with the display cases, and space in the library to set up the exhibition.

References

Works Cited

- Adams, Richard. "A History of 'Adventure.'" Colossal Cave Adventure Page.
<http://www.rickadams.org/adventure/>
(accessed 27 February 2005).
- Australian Museum Audience Research Center. "Writing Text and Labels: Review of the Literature." May 2000.
<http://www.amonline.net.au/amarc/pdf/research/text.pdf>
(accessed 12 December, 2004).
- Belcher, Michael. Exhibitions in Museums. Washington, D.C. Smithsonian Institution Press, 1991.
- Bellis, Mary. "The History of Computers – Computer History Timeline." *About.com*.
<http://inventors.about.com/library/blcoindex.htm>
(accessed 15 February 2005).
- Biondich, Paul. "Wing Commander." *All Game Guide*.
<http://www.gamerankings.com/itemrankings/launchreview.asp?reviewid=321177>
(accessed 7 January, 2005).
- Blevins, Tal. "Max Payne." *IGN.com*, 27 July 2001.
<http://pc.ign.com/articles/161/161645p1.html>
(accessed 7 February 2005).
- "Blizzard Entertainment Press Release." Blizzard, 20 September 2002.
http://www.angelfire.com/games4/starcraft_g/info/press_release.html
(accessed 1 March 2005).
- Boulding, Aaron. "Star Wars: Knights of the Old Republic." *IGN.com*, 13 July 2003.
<http://xbox.ign.com/articles/428/428645p1.html>
(accessed 8 February 2005).
- Bowen, Kevin. "Wolfenstein 3D." *Classic Gaming*.
<http://www.classicgaming.com/rotw/wolf3d.shtml>
(accessed 12 February, 2005).
- "Brief Video Game Console History." *Playstation 3 Portal*, 2003.
<http://www.ps3portal.com/?page=history>
(accessed 15 February 2005).
- Brundage, Darryl. "Pitfall!." *The Atari Times*.

<http://www.ataritimes.com/2600/reviews/pitfall.html>
(accessed 15 February 2005).

Bush, Katie. "A History of Real-Time Strategy Games." *GameSpot*.
http://www.gamespot.com/gamespot/features/all/real_time/index.html
(accessed 20 February 2005).

Bush, Katie and Cheung, James "Best and Worst of 2005." *Gamespot.com*.
<http://www.gamespot.com/gamespot/features/all/bestof2002/>
(accessed 9 February 2005).

Chick, Tom. "StarCraft" *IGN.com*, 2 June 2000.
<http://pc.ign.com/articles/152/152159p1.html>
(accessed February 8 2005).

Chin, Elliott, and Kasavin, Greg. "Gamespot's History of Star Wars Games." *Gamespot*.
http://www.gamespot.com/features/starwars_hs/tie.html
(accessed 11 January 2005).

"Classic: Iup.com's Essential 50." *Iup.com*.
<http://boards.iup.com/do/feature?cId=3137685>
(accessed 8 February 2005).

Coin Op Museum. "Coin-Op Museum: Defender." *Killer List of Video Games*.
<http://www.klov.com/D/Defender.html>
(accessed 3 February 2005).

"Computer Games – The 1983 Crash." *M/Cyclopedia of New Media*, 22 October 2004.
http://wiki.media-culture.org.au/index.php/Computer_Games_-_The_1983_Crash
(accessed 10 February 2005).

Davis, Cameron, and Shoemaker, Brad. "The History of Sonic the Hedgehog." *Gamespot*.
http://www.gamespot.com/gamespot/features/video/hist_sonic/
(accessed 11 January 2005).

Davis, Ryan. "The Greatest Games of All Time: SMB3." *GameSpot*.
<http://www.gamespot.com/gamespot/features/all/greatestgames/p-53.html>
(accessed 23 January, 2005).

DeRoux, Kenneth. "Basic Techniques for Making and Mounting Exhibit Labels." *Museum State of Alaska*.
<http://www.museums.state.ak.us/Bulletin/makinglabels.html>
(accessed 10 December 2004).

DeRoux, Kenneth. "Exhibit Labels, Some Basic Guidelines for Small Museums." *Museum State of Alaska*.
<http://www.museums.state.ak.us/Bulletin/labels1.html>

(accessed 10 December 2004).

Dulin, Ron. "Half-Life." *Gamespot.com*, 20 November 1998.
<http://www.gamespot.com/pc/action/halflife/review.html>
(accessed 8 February 2005).

Dulin, Ron. "StarCraft." *Gamespot.com*, 15 April 1998.
<http://www.gamespot.com/pc/strategy/starcraft/review.html>
(accessed 8 February 2005).

"Exhibit Design Guidelines." *Sciencenter*.
<http://sciencenter.org/ExhibitDesignGuidelines.htm>
(accessed 8 December 2004).

Gerstmann, Jeff. "The Legend of Zelda: Ocarina of Time." *Gamespot.com*,
23 November 1998.
<http://www.gamespot.com/n64/adventure/legendofzeldaoot/review.html>
(accessed 8 February 2005).

"History of Gaming Interactive Timeline of Game History." *PBS Video Game
Revolution*.
http://www.pbs.org/kets/videogamerevolution/history/timeline_flash.html
(accessed 10 February 2005).

Jerz, Dennis. "Colossal Cave Adventure." *Interactive Fiction – Foundational Works*,
10 December 2001.
<http://jerz.setonhill.edu/if/canon/Adventure.htm>
(accessed 27 February 2005).

Kasavin, Greg. "The Greatest Games of All Time: *Star Control II*." *GameSpot*.
<http://www.gamespot.com/gamespot/features/all/greatestgames/p-7.html>
(accessed 23 January 2005).

Kasavin, Greg. "EverQuest." *Gamespot.com*, 2 April 1999.
<http://www.gamespot.com/pc/rpg/everquest/review.html>
(accessed 9 February 2005).

Kasavin, Greg. "Warcraft III: Reign of Chaos." *Gamespot.com*, 3 July 2002.
<http://www.gamespot.com/pc/strategy/warcraft3reignofchaos/review-3.html>
(accessed 10 February 2005).

Kasavin, Greg. "Star Wars: Knights of the Old Republic" *Gamespot.com*, 15 July 2003.
<http://www.gamespot.com/xbox/rpg/starwarsknightsoftor/review-3.html>
(accessed 8 February 2005).

Kasavin, Greg. "Star Wars Galaxies: An Empire Divided." *Gamespot.com*, 7 July 2003.

- <http://www.gamespot.com/pc/rpg/starwarsgalaxiesaned/review.html>
(accessed 20 January 2005).
- Kasavin, Greg. "World of Warcraft." *Gamespot.com*, 29 November 2004.
<http://www.gamespot.com/pc/rpg/worldofwarcraft/review.html>
(accessed 6 February 2005).
- Kasavin, Greg. "Final Fantasy VII Review." *GameSpot*, 29 September 1997.
<http://www.gamespot.com/ps/rpg/finalfantasy7/review.html>
(accessed 27 February 2005).
- Kishan, Amir. "Mega Man Walkthrough." *Game FAQs*, 1 August 2004.
http://db.gamefaqs.com/console/nes/file/mega_man_1.txt
(accessed 10 February 2005).
- "Legend of Zelda FAQ." *Game FAQs*, 2004.
http://db.gamefaqs.com/console/nes/file/legend_of_zelda_j.txt
(accessed 14 February 2005).
- "The Legend of Zelda." *Nintendo*, 19 July 2004.
http://www.zelda.com/universe/info_z1.html
(accessed 27 February 2005).
- Lopez, Vincent. "The Sims." *IGN.com*, 5 February 2000.
<http://pc.ign.com/articles/161/161754p1.html>
(accessed 8 February 2005).
- McKay, Tom. "Exhibit Design: The Language of Artifacts." Wisconsin Historical Society, December 1982.
<http://www.wisconsinhistory.org/localhistory/articles/artifacts.asp>
(accessed 12 February, 2005).
- "Museum & Gallery Lighting." *MuseumLighting.com*
<http://www.museumlighting.com/aboutoptics.html>
(accessed 9 February 2005).
- "Mystery House." *Moby Games*, 19 August 2003.
<http://apple2.mobygames.com/game/shots/p,31/gameId,9312/gameShotId,47680/>
(accessed 27 February 2005).
- Nelson, Randy. "Metal Gear Solid." *IGN.com*, 21 November 1998.
<http://psx.ign.com/articles/150/150569p1.html>
(accessed 7 February 2005).
- "NES Classics : Super Mario Brothers." *Gamekult.com*, 2000.
<http://www.gamekult.com/tout/jeux/images/ME0000475417>
(accessed February 25 2005).

- Nutt, Christian, and Speer, Justin. "The History of Mega Man." *Gamespot*.
<http://www.gamespot.com/features/6076983>
(accessed 27 February 2005).
- O'Brien, Paul. "Game Reviews A: Adventure (aka Colossal Cave)." *SPAG (Society for the Promotion of Adventure Games)*, 12 October 1999.
<http://www.sparkynet.com/spag/a.html#advent>
(accessed 27 February 2005).
- Park, Andrew Seyoon. "The Sims." *Gamespot.com*, 11 February 2000.
<http://www.gamespot.com/pc/strategy/sims/review.html>
(accessed 2 February 2005).
- Perry, Doug. "Metal Gear Solid." *IGN.com*, 21 November 1998.
<http://psx.ign.com/articles/150/150569p1.html>
(accessed 7 February 2005).
- Persson, Hans, and Mcier, Stefan. "Mainframe Adventures." *Adventureland*.
http://www.if-legends.org/~adventure/Mainframe_adventures.html
(accessed 27 February 2005).
- "Populous." *Answers.com*.
<http://www.answers.com/Populous>
(accessed 27 February 2005).
- Schultz, Andrew. "Ultima IV Quest of the Avatar." *Game FAQs*, 2000.
http://db.gamefaqs.com/computer/doswin/file/ultima_iv_a.txt
(accessed February 3 2005).
- Schneider, Peter. "The Legend of Zelda: Ocarina of Time." *IGN.com*,
25 November 1998.
<http://ign64.ign.com/articles/150/150437p1.html>
(accessed 7 February 2005).
- Sengstack, Jeff. "Myst." *GameSpot*.
<http://www.gamespot.com/pc/adventure/myst/review.html>
(accessed 8 January 2005).
- Shaw, Kevan. "Museum and Gallery Lighting." *Kevin-Shaw.com*.
<http://www.kevan-shaw.com/articles/mus-gall/museums/Museum-Galleries.html#Introduction>
(accessed 20 January 2005).
- Skerritt, Peter. "Review: Ninja Gaiden." *Nintendo Land*.
http://www.nintendoland.com/home2.htm?reviews/nes/ninja_gaiden_3.htm.

(accessed 27 February 2005).

“Starflight.” *Answers.com*.
<http://www.answers.com/Starflight/>
(accessed 27 February 2005).

Thomas, David. “Video Game Timeline.” Spring 2003.
<http://www.buzzcut.com/filemgmt/visit.php?lid=3>
(accessed 14 February 2005).

W, Dan. “Super Mario Bros. 3.” *The Mushroom Kingdom*.
<http://www.classicgaming.com/tmk/smb3.shtml>
(accessed 27 February 2005).

Welu, Dr. James. Personal Interview. December 7, 2004.

Weyrich, Steven. “Apple II History Software.” *Apple II History*, 17 January 2005.
<http://apple2history.org/history/appy/aha82.html>
(accessed 12 February 2005).

Wong, Darrell. “Zork I.” *Game FAQs*, 23 August 2001.
http://db.gamefaqs.com/computer/doswin/file/zork_i_a.txt
(accessed 15 February 2005).

“Worcester Art Museum – Press Release.” *Worcesterart.org*, 14 December 2000.
<http://www.worcesterart.org/Information/PR/Past/3-3-00.html>
(accessed 10 December 2004).

Young, Jeffrey Adam. “Full Throttle” *GameSpot*.
<http://www.gamespot.com/pc/adventure/fullthrottle/review.html>
(accessed 20 February 2005).

Appendices

Appendix 1: Artifacts List

The following spreadsheet contains a categorized list of artifacts divided into cases. The display cases are labeled A – G. Please note that the artifacts are delegated into specific cases chronologically with size taken into account to the best of our knowledge. This may be subject to change upon the arrival of the artifacts.

Case / Artifact	Type	Company / Developer	Year
A			
Star Trek vol. 4	Newsprint Tabloid	People's Computer Company	1976
Adventure	Videogame for Atari VCS	Atari	1978
Adventureland, S.A.G.A	Software for Apple II	Adventure International	1979
Savage Island	Software for Apple II	Adventure International	1980
Wizardry: A Game of Fantasy and Adventure	Manual	Sir-Tech Software	1981
Wizardry: Proving Grounds of the Mad Overlord	Software for Apple II	Sir-Tech Software	1981
Upper Reaches of Apschai	Software for TRS-80 or Atari 400/800 computer	Automated Simulations/Epyx	1981
Castle Wolfenstein	Software for Apple II	Muse Software	1981
The Art of Computer Game Design	Draft manuscript (first rev.)	Chris Crawford	1982
B			
Upper Reaches of Apschai	Software for TRS-80 or Atari 400/800 computer	Automated Simulations/Epyx	1981
Castle Wolfenstein	Software for Apple II	Muse Software	1981
The Art of Computer Game Design	Draft manuscript (first rev.)	Chris Crawford	1982
Donkey Kong	Software for Colecovision	Coleco Industries / Nintendo	1982
Star Wars: Jedi Arena	Atari VCS Videogame	LucasFilm/Parker Brothers	1983
Star Wars: The Empire Strikes Back	Atari VCS Videogame	LucasFilm Games	1983
Mario Bros.	Software for Atari 5200 Supersystem	Nintendo	1983
Mindwheel, 1984	Software for Commodore 64 or DOS	Brøderbund	1984
C			
King's Quest	Software for IBM PC-jr	IBM	1984
Ballblazer	Apple II Software	Epyx Inc.	1985
Star Wars	NES Videogame	LucasFilm Games	1985
Wizard's Crown	Software for Apple II	Strategic	1985

Wizard's Crown	Software for Apple II	Simulations, Inc. Strategic Simulations, Inc.	1985
Mind Mirror	Software for Commodore 64	Electronic Arts	1985
Ultima I	Software for IBM PC	Origin Systems, Inc.	1985
D			
Gauntlet	Videogame for NES	Tengen	1985
Mario Bros.	Videogame for NES	Nintendo	1985
Super Mario Bros. 3	Videogame for NES	Nintendo	1985
The Legend of Zelda	Videogame for NES	Nintendo	1987
Pool of Radiance	Software for Commodore 64	Strategic Simulations, Inc.	1988
Neuromancer	Software for Commodore 64	Interplay Productions	1988
Flyer for Essex MUD	Digital Facsimile	?	1989
"Explore Fantastic new Worlds of Computer Gaming"	Product Catalog	Strategic Simulations, Inc.	1989
Metal Gear	Software for IBM PC	Ultra Software Corporation	1989
E			
Maniac Mansion	NES Videogame	Jaleco	1990
DragonStrike	Videogame for NES	Strategic Simulations, Inc.	1990
Secret of the Silver Blades	Software for DOS-compatible computer	Strategic Simulations, Inc.	1990
The Way of the Avatar (A Guide to Ultima IV)	Booklet	Origin Systems, Inc.	1990
Ultima IV	Software for IBM PC	Origin Systems, Inc.	1990
Secret Weapons of the Luftwaffe	PC Demo Software	Lucas Arts	1991
Super Mario World	Videogame for NES	Nintendo	1991
F			
Wolfenstein	PC Software	id Software	1992
The Terminator	Videogame for NES	Mindscape	1992
The Legend of Zelda: A Link to the Past	Videogame for NES	Nintendo	1992
King's Quest V	Videogame for NES	Sierra On-Line/ Konami	1992
Wolfenstein	NES Videogame	id Software	1993
Full Throttle	MAC Software	Lucas Arts	1994
G			
Star Wars: Tie Fighter	PC Demo Software	Lucas Arts	1996

Afterlife	PC Demo Software	Lucas Arts	1996
Mortimer and the Riddles of the Medallion	PC Demo Software	Lucas Arts	1996
Half-Life	PC Software	Valve/Sierra	1998
Escape from Monkey Island	PC Demo Software	Lucas Arts	2000
Asheron's Call: Dark Majesty	PC Software	Microsoft	2002
Indiana Jones and the Temple of Doom	PC Demo Software	Lucas Arts	2003
Star Wars Galaxies: An Emperor Divided	PC Software	Lucas Arts	2003

Appendix 2: Layouts

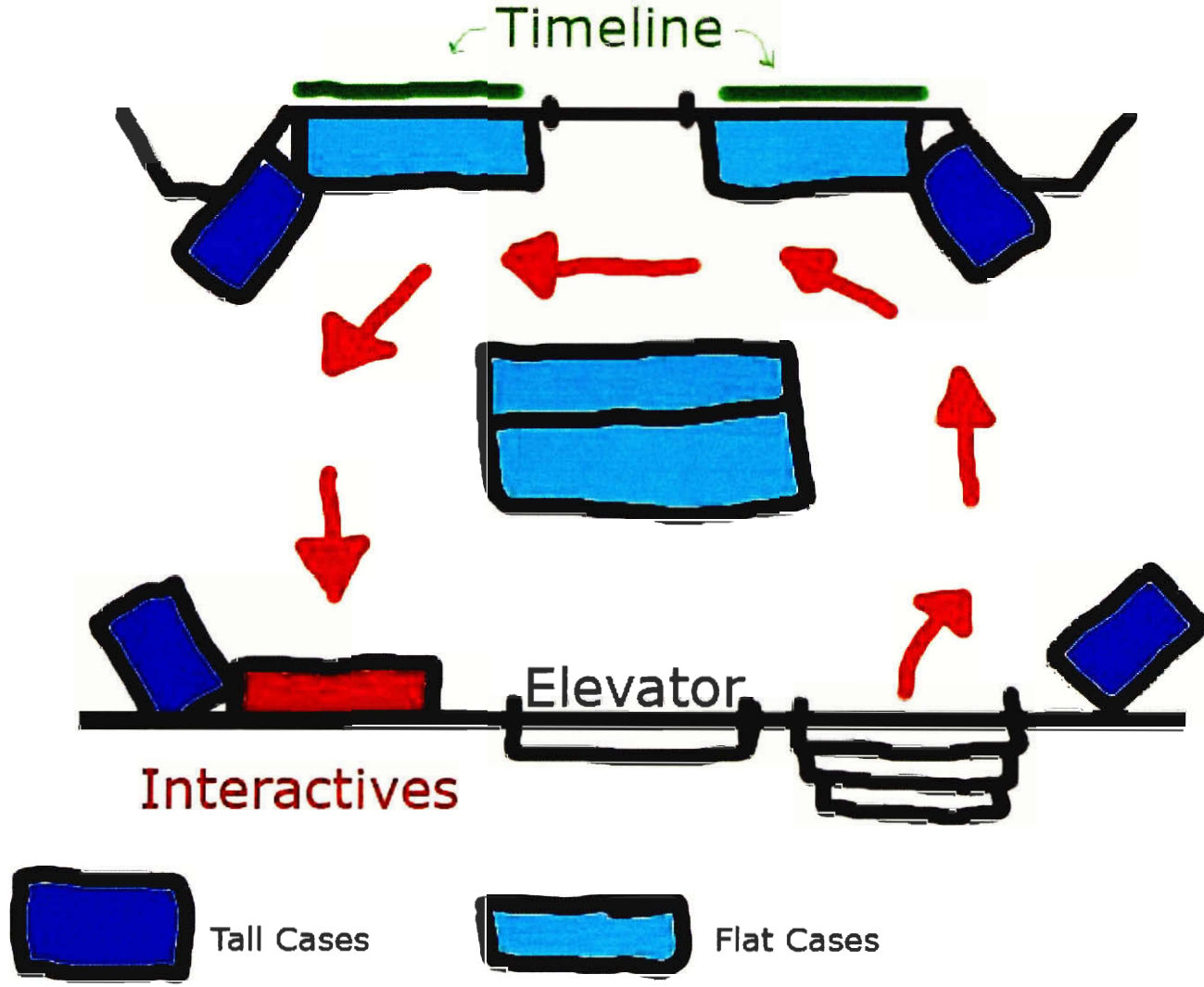

This is the initial concept sketch of the exhibit layout.

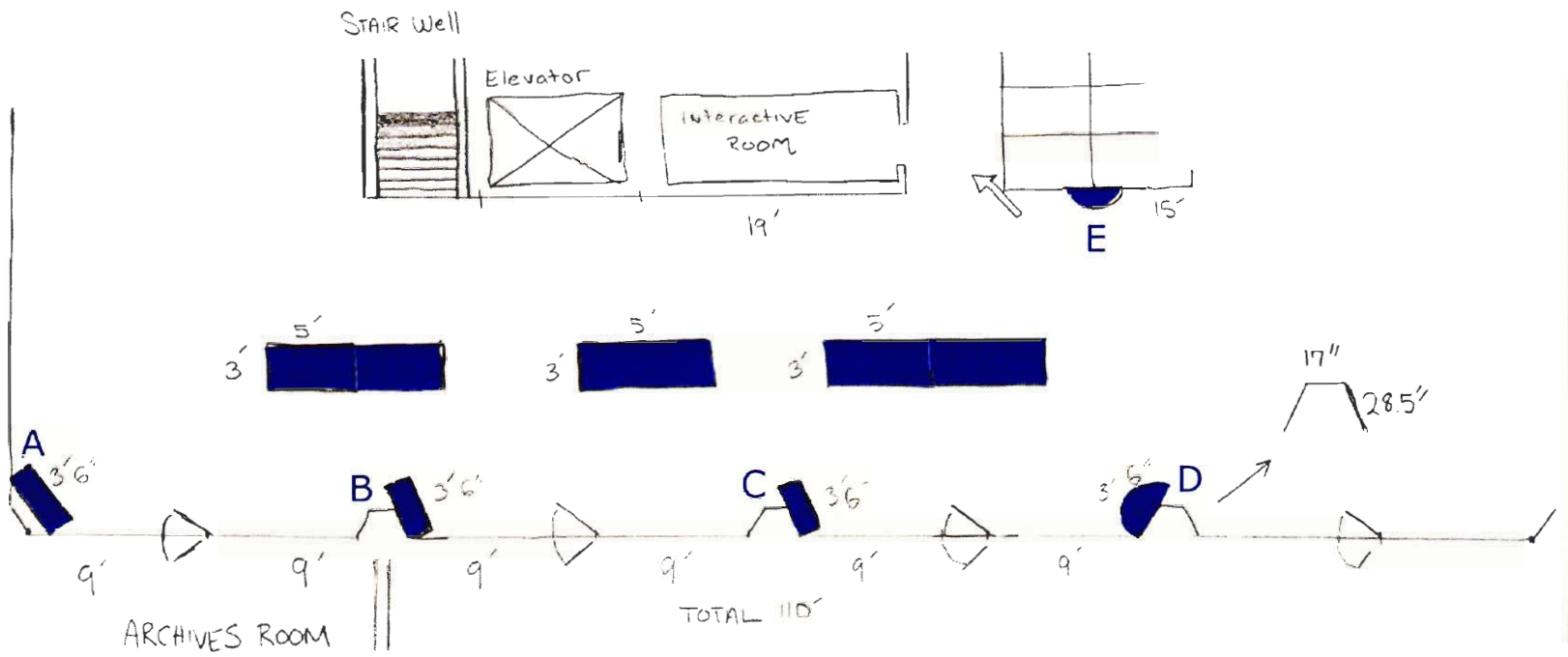

This is the second revision of the exhibit layout.

Table with
interactive
game
consoles

Case

Tables with PC Video Clips

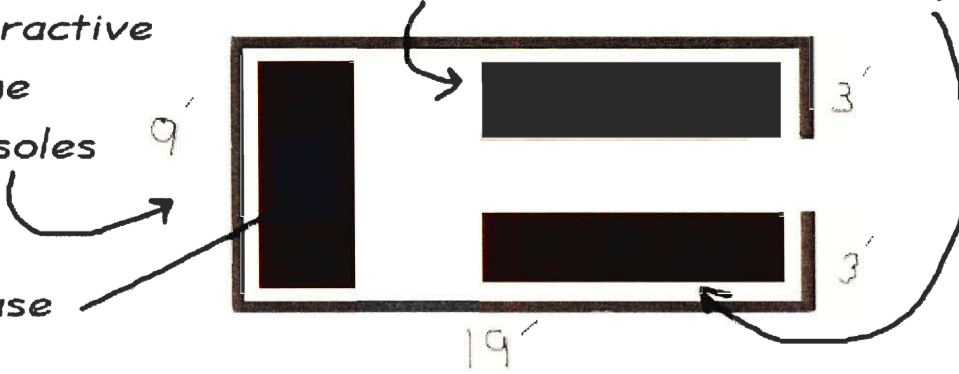

This is the layout of the Interactive Media room.

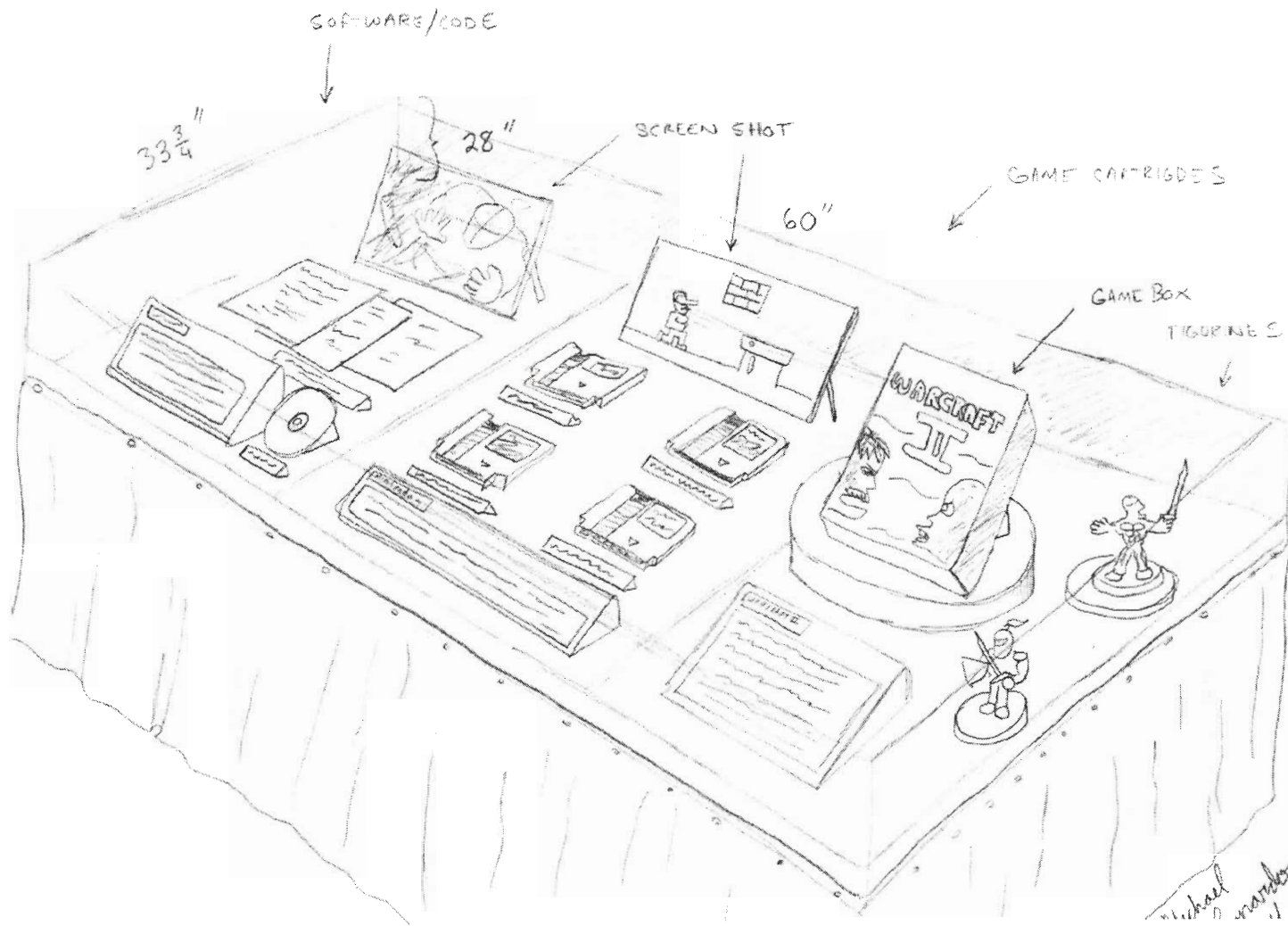

This is an artist's concept sketch of an individual case layout.

Appendix 3: Timeline

The following is a timeline outlining the significant events throughout the history of storytelling in video games. It is based on the preceding paper and our research, thus the sources in the work cited section apply here as well.

Year	Event
1972	<i>Colossal Cave</i> is created. It is text-based maze game, is developed by William Crowther based on his actual adventure in a cave. The game is used as a template and is greatly modified in the coming years.
1976	<i>Colossal Cave</i> is picked up by Don Woods, who incorporates fantasy characters with allusions to the popular <i>Lord of the Rings</i> trilogy. It becomes one of the first games to merge a known genre with another game. It becomes a wildly popular among the computer literate and many spin-offs are soon created.
1978	<i>Adventure</i> is commercialized and ported to Atari VCS. The common console allows the game to be enjoyed by the general public.
1980	<i>Zork</i> is released on the TRS-80 home computer. It is the direct successor to the mainframe game <i>Adventure</i> , and is the first commercially released text parsing game. <i>Mystery House</i> is released for the Apple II computer by On-Line systems (now Sierra On-Line). The first adventure based text parsing game which also combined graphics. <i>Akalabeth</i> is released for the Apple II computer. It is the predecessor to the popular Ultima series. It is the paramount RPG playing experience.
1981	<i>Donkey Kong</i> is released in the arcades. It introduced the “save the princess” theme used in many later games.
1982	<i>Pitfall</i> is released for the Atari 2600. It is the first game with a side scrolling environment.
1986	<i>Super Mario Brothers</i> for the Nintendo Entertainment System is released. It successfully combined the “save the princess” theme from <i>Donkey Kong</i> , and the side-scrolling environment first implanted in <i>Pitfall</i> . <i>The Legend of Zelda</i> is released for the Nintendo Entertainment System. It follows the “save the princess” theme, but also adds Role-playing game elements. The first console game to implement a save game feature.
1986	<i>Starflight</i> is released on the PC. The game pioneered open-ended gameplay, allowing players to control the storyline.
1987	<i>Mega Man</i> is released for the Nintendo Entertainment System. One of the first console games that allowed the player to progress a non-linear fashion.
1989	<i>Populous</i> is released for the PC. This is the first god game ever released, giving the player complete control of the game environment.
1990	<i>Super Mario Brothers 3</i> is released. <i>SMB3</i> sells over 17 million copies due to the success of the movie released beforehand, “The Wizard,” based on the future release of the game.

	<p>The <i>Wing Commander</i> series is started. The series brings the idea of movie quality cinematics and plot into the mainstream of gaming.</p>
1991	<p><i>Super Mario World</i> is released. With new technology allowing more space and multimedia, the Mario world is vastly expanded.</p> <p><i>Sonic the Hedgehog</i> is released, starting a series of Sonic games. Sonic was one the first characters designed specifically to show off a technological advance – in this case processor speed.</p>
1992	<p><i>Wolfenstein 3D</i> is released. <i>Wolfenstein</i> introduces the public to a new genre, the first person shooter, which at first pulls gaming away from storytelling and pushes it toward violence.</p> <p><i>Star Control II</i> is released. The game is a milestone in the progress of genre merging. The game is an epic sci-fi space shooter role-playing game.</p>
1994	<p><i>Tie Fighter</i> is released. Based in the Star Wars universe, <i>Tie Fighter</i> is one of the first games to place the player on the known “bad guy” team (the Empire) and actually keep the player in that role until the end.</p>
1995	<p>Both <i>Warcraft II</i> and <i>Command & Conquer</i> are released. Both pioneer the real time strategy genre which takes story to a grander scale with armies and nations rather than instead of individuals.</p> <p><i>Myst</i> is released. <i>Myst</i> is played through still frame pictures and is entirely puzzle based. It is one of the most unique and popular games ever.</p>
1996	<p><i>Resident Evil</i> is released. It is the first mainstream survival horror game. The game is so popular that many people buy Play Station for the sole purpose of playing it.</p>
1997	<p><i>Ultima Online</i> is released. It introduces the massively multiplayer online role-playing game genre. Through the game people from around the world can play in the same world and share quests together.</p>
1998	<p><i>The Legend of Zelda: Ocarina of Time</i> is released. The game is the first 3D incarnation of Zelda and its stunning portrayal of the story sets a new precedence for console action/adventure games.</p> <p><i>Metal Gear Solid</i> is released. A brilliant example of cinematography in video games, this title employs new technology in order to present its action based story in a fluid and cohesive manner. Additionally, it solidifies the stealth/action genre by implementing it in a way that makes it accessible to everyone.</p> <p><i>Half-Life</i> is released. In addition to revolutionizing the first person shooter in terms of gameplay, the game makes notable improvements to storytelling. Rather than using typical FMV sequences, the story is driven by in game dialogue and scripted events.</p> <p><i>StarCraft</i> is released. Though there had been earlier story driven real time strategy games, this game takes the genre to new heights. It presents its story</p>

	through the use of pre/post mission briefings, in game dialogue, and FMV sequences, further allowing the player to become immersed in the story.
1999	<i>EverQuest</i> is released. While not the first massively multiplayer online role-playing game, it still is significant in that it presents the genre in a new way through more elaborate character creation, a larger game world, and more player to player interaction.
2000	<i>The Sims</i> is released. The game follows the format of earlier “Sim” games, however this time it simulates daily life. It is an interesting evolution of story telling in that there is no predefined story; rather the player must create their own based on how they allow their “Sim” people to live and interact.
2001	<i>Grand Theft Auto 3</i> is released. The first two games in the series did much in the way of establishing it, however this game redefines it. By allowing the player to either play through a well written and implemented story, or simply explore a fully functional 3D city, the game gives players a sense of freedom like no other previously seen in an action game. The game’s crime based storyline causes more controversy than had ever been seen over a video game. <i>Max Payne</i> is released. An action /shooter in nature, the game takes storytelling in new and different directions. Through the use of intermittent novel like narrations by the main character, the very dark story is engrained in the players mind.
2002	<i>WarCraft III: Reign of Chaos</i> is released. The third installment in the WarCraft series, the game differs greatly from previous story driven real time strategy games. Through the use of a very advanced 3D game engine, the majority of the story is told on the virtual battlefield as events unfold during gameplay.
2003	<i>Star Wars Galaxies: An Empire Divided</i> is released. The first Star Wars role-playing game, and the first massively multiplayer game based on a movie license. Though plagued with inherent launch glitches, the game is still immensely popular and applies one of the most comprehensive imaginary worlds in recent history (Star Wars) to a game genre that can fully express it. <i>Star Wars: Knights of the Old Republic</i> is released. Another Star Wars RPG, however this time a single player only game. The game is described by many as one of the best Star Wars experiences since the original trilogy. Its countless FMV sequences, hours of spoken dialogue, and fully developed/well written story make the game an instant success and a notable leap in storytelling.
2004	<i>World of WarCraft</i> is released. The first massively multiplayer online role-playing game set in the WarCraft universe, the game makes marked improvements to how story is presented.

Appendix 4: Interactive Media

The actual content of this section was described in detail above. All of the components detailed will be stored at the WPI Gordon Library Archive until the exhibition in October of 2005. All of the video footage that will be included can be found on the enclosed DVD-R disc in the subdirectory labeled "Video Clips". The videos are all in windows compatible formats and should be playable with any windows media application. The following is a detailed list of all the items that will be part of the interactive media room. Please note that some of the components will be on loan from various places, and thus will not be in storage following/prior to the exhibition.

- Personal Computers
- Computer Monitor
- Televisions (2)
- Sony Playstation Console
- Nintendo Entertainment Console
- Security measures for both consoles
- Final Fantasy VII (PSX)
- The Legend of Zelda (NES)
- Mega Man (NES)
- Super Mario Bros. 3 (NES)
- Ninja Gaiden (NES)

The following is a complete listing of the video clips that will be running in the interactive media room.

Grand Theft Auto 3 - Trailer.mpg
Grand Theft Auto 3 - Video Tour.mpg
Half-Life - Game Footage 1.mpg
Legend of Zelda - Gameplay Footage.wmv
Mario Brothers 2 - Gameplay footage.wmv
Max Payne - Trailer 1.mpg
nVidia Panel Discussion.mpg
Resident Evil 4 - Trailer 1.mpg
Resident Evil 4 - Trailer 2.mpg
Resident Evil 4 - Trailer 3.mpg
Resident Evil 4 - Trailer 4.mpg
Resident Evil GC - Trailer 1.mpg
Star Wars Galaxies - Gameplay Footage 1.mpg
Star Wars Galaxies - Trailer 1.mpg
Star Wars Galaxies - Video Tour.mpg
Star Wars Knights of the Old Republic – Interview 1
Star Wars Knights of the Old Republic – Interview 2
Star Wars Knights of the Old Republic – Interview 3
Star Wars Knights of the Old Republic – Interview 4
The History of Grand Theft Auto.mpg

The History of Metal Gear.mpg
The Legend of Zelda Wind Waker - Trailer
The Wizard Trailer.wmv
Ultima - Gameplay Footage.wmv
World of Warcraft - Env.mpg
World of Warcraft - Interview 1.mpg
World of Warcraft - Trailer 1.mpg

Appendix 5: Enclosure for Interactive Media

The following are photographs of the enclosure we designed and constructed for the two consoles to be included in the interactive media room. The enclosure can be found in storage at the Gordon Library until the exhibition time.



Appendix 6: Budget Request and Outline

The following is a budget request that was submitted to the IGSD; it is a description of the project and project goals and is followed by a detailed outline of the budget.

Introduction

Jump over some barrels and rescue the girl. That one sentence summarizes the entire story of Mario, Donkey Kong, and the Princess in Nintendo's original hit "Donkey Kong" from 1981. Someone once said all you needed to have a story was a problem and a resolution. Donkey Kong had just that and that alone. Background? History? Nope. Just a princess held captive by a monkey and some random plumber out to rescue her.

Why wasn't the storyline more involved? How did the Princess get captured? Why would Donkey Kong want to kidnap her? Who was this Mario character, how did he fit in? There's a simple reason for the lack of elaboration; the developers didn't have the means to convey a more detailed plot. Back in 1981 memory, processing time, and the lack of development tools were all major problems in the development of storylines for games. The actual gameplay itself was already taking up enough computing resources as it was. Trade offs needed to be made and when it came down to it, the storyline was just not as critical to the game as the actual interactive playing. In short, technology was the bottleneck that controlled the evolution of storytelling in video games. That is the subject of our IQP; a museum exhibit of the evolution of storytelling in video games as it relates to advances in technology.

Our project is to construct and setup that museum exhibit in the WPI library. The project was inspired by Dr. David Finkel who saw a similar exhibit displayed at Stanford University in California. While there, Professor Finkel was able to arrange the future rental of large sets from Stanford's video game artifact collection. Through the funding of WPI, ourselves, and sponsors we collect, we intend on collecting a variety of other video game artifacts as well. We will organize them with a common theme and construct a successful and interesting exhibit based on our subject. We hope to be a main event to kick off the start of the proposed WPI Interactive Media and Game Development.

We hope our exhibit attracts several audiences. Given that many of WPI's students pass through the library, we expect much of the student body to make up our intended audience. Along with them many teachers would find the exhibit enlightening especially considering the proposed IMGD major. Anyone who is interested in game development, gaming, or just games in general would be a target of our marketing. Hopefully our exhibit we not be limited to on-campus and will attract off-campus attention as well.

The fruits of our labor, the exhibit itself, will be presented B-Term 2005 with the assistance of the library to host it. We, the project group, will help will the setup and maintenance. The hope is that the project will muster interest in the subject and perhaps even prompt interest into further investigation. Primary, however, the project will be for education.

Our main method in which to conduct the project is to first make contacts and

start collecting artifacts in A term, plan out the exhibit and build it in B term, and finally do the report and other paperwork in C term. The following year during B-term we would come back and actually set up the exhibit itself for all to see.

Literature Review

There have been several other organizations that have accomplished projects with similar themes. One such particular example is the work of Dr. Henry Lowood and Mr. Casey Alt of Stanford University, who has orchestrated an exhibit entitled “Fictional Worlds, Virtual Experiences: Storytelling And Computer Games.” This displays a more general history of video gaming through the use of various presentation methods including display cases and interactive multimedia.

Other works which we will base our project material on include:

- *High Score!* by Rusel Demaria and Johnny Wilson
- *Exhibitions In Museums* by Michael Belcher
- *The Display Book* by Kerry Dexter
- *Mounting and Preserving Pictorial Materials* by George T. Yeamans
- Andrew Rollings and Ernest Adams on Game Design by Andrew Rollings
- *Gaming 101: A Contemporary History of PC and Video Games* by George Jones

This project will be focusing both on the evolution of storytelling in Video Games, and the design and construction of a museum exhibit. The exhibit design is critical for the success of this project. The audience will expect an eye catching, informative, and entertaining exhibit to promote the proposed Interactive Media and Game Development major. Research on the history of video games will be necessary to explain the significance of the artifacts that will be used for the exhibition.

Procedure

The main component of this project is a museum exhibit that will focus on the evolution of storytelling through videogames. The exhibit will also focus on how the advancement of technology has affected this evolution. At the dawn of the videogame era, simplicity was present throughout the games in terms of design and story. In some cases story was not even present at all. As the technology evolved, developers were given more freedom in design and it became increasingly more feasible to tell a story through the use of a videogame. Today story is an integral part of most videogames. In many current games, all the elements of any story can be found such as character development, plot development, and setting changes. The medium has evolved from a point at which the players simply played a game, to the point at which the player can be completely immersed in an interactive story. We plan to trace this evolution, and lay it out in a comprehensive museum exhibit.

The logistics of this project are as follows. We plan to, and have begun to, take care of all preliminary activities during A-term 3004. These activities include, finding

any additional funding for the project possibly from off campus sources. Designing the layout of the actual exhibit, deciding on any supplementary information to be distributed at the exhibit, and establishing a list of the artifacts to be included in the exhibit. During B-term 2004 we plan to actually construct the exhibit main structures. We will not actually be running the exhibit, however we plan to build as much as possible before B-term 2005 when the exhibit will actually run. The elements we will be constructing will include display cases, computer display systems, lighting structures, and any other elements essential to the exhibit short of the actual artifacts. Finally, during C-term 2005 we plan to write the supplementary material for the exhibit. This will include a catalog and possibly a timeline. We will also be doing our IQP write up this term. As this exhibit is not slated to run until B-term 2005, we will be doing a significant amount of preparation at that time as well. This will include setting up the exhibit itself, organizing any lectures and guest speakers, and orchestrating the exhibit opening.

For this project we will require a good amount of materials. The majority of the artifacts will be supplied by Stanford University from their own collection; however we may need additional artifacts of our own as our planning progresses. We will also need general building supplies for constructing structural elements such as wood and wood working supplies. Several electronic displays and interactive displays are planned so we will also need at least one computer most likely more than one, and any other equipment needed to set up these types of displays. Finally, lighting is going to be an essential part of the design of the exhibit, thus we will need to purchase or rent lighting fixtures as needed.

In terms of data, it will be required of us to obtain a list of artifacts being supplied to us by Stanford, and also compile a list of artifacts we will need to obtain ourselves. We will be able to make a more extensive plan for the artifact list as we begin to design the layout of the exhibit and to apply the theme of the exhibit.

We have made projections for several costs relevant to this project. Though our budget is significantly greater than \$400, we felt it would be more feasible to lobby for off-campus sponsorship for the majority of it. The costs indicated here are the most important to the project due to the fact that we have specifically accounted for acquiring the Stanford University artifacts in all of our initial planning. Not being able to obtain these artifacts would result in a severe set back to the project. The shipping costs may seem high, however there are over 100 artifacts being sent to us from California. Also, we have been lucky enough for Stanford University to allow us the use of their artifacts, thus we feel that it is our obligation to ensure the safety of the artifacts while they are here at WPI but also while they are in transit. The loss of any items would be unfortunate and we realize that many of these objects are valuable, so we have factored in shipping insurance costs into our budget for this reason. Further more, we are aware that each student is required to contribute \$25 to the project per term. There are four students involved in the process, so we have factored in \$300 to be contributed by the student team. This money has been accounted for in the budget on the next page, and is detailed on the final page of this document.

Budget Outline

cases; general decoration)

\$200	Shipping of Artifacts from Stanford University
\$200	Shipping Insurance for Artifacts
\$100	Museum Exhibit Research (Visiting current museum exhibits such as Museum of Science in Boston, details on next page)
\$200	Basic Interactive Media Section (details on next page)
\$600	Exhibit Supplies (Construction materials for enclosures and display cases; general decoration)
\$1000	Additional Interactive Media and Electronics
\$1000	Advertising - approximately 200-300 posters
\$700	Grand Openings, Catering
\$800	Public speakers, transportation
\$1500	Catalog Printing

The following details how our (the students) \$25 per term has been/will be spent.

Boston Trip Costs

43.75 miles x \$0.32 = \$14.00

\$5.00 /person for train tickets back and forth x 4 = \$20.00

\$20.00 /person museum entry x 4 = \$80.00

Interactive Media Room Costs

Sony PSX - \$40.00 after shipping

Final Fantasy VII - \$20.00 after shipping

Nintendo Entertainment System - \$30.00 after shipping

The Legend of Zelda - \$10.00 after shipping

Mega Man - \$10.00 after shipping

Super Mario Bros. 3 - \$10.00 after shipping

Ninja Gaiden - \$10.00 after shipping

Security Housing for Consoles - \$56.00

Appendix 7: Font and Colors

The following is an example of the font we chose for the exhibition. All relevant written works featured within the exhibit will appear in this type face. It is called “Jolt – Wide”. The color theme (blue, red, and black) is also exemplified in the image.



Appendix 8: Confirmation of rights to use video clips

The following is an email response from Gamespot.com editor Greg Kasavin, confirming the use of Gamespot.com video clips in our exhibition as acceptable use.

Hi Nick,

Please consider your request for permission approved. We only ask that you make sure any assets you use from GameSpot to be attributed with the GameSpot logo or GameSpot.com URL, which is required by CNET's legal department. Thanks for thinking of us for your project.

Incidentally, the timing of your request is interesting, since I happen to be working on a big feature story on storytelling in games. At any rate, I'd be interested to know what sort of response you get from the exhibit, so if you have the opportunity, please drop me a line. Good luck,

Greg Kasavin
Executive Editor, GameSpot

-----Original Message-----

From: Apache User [ROLE] [<mailto:httpd@c10-sparta2.cnet.com>]

Sent: Tuesday, March 01, 2005 6:39 PM

To: Alicia Bradley

Subject: request for permissions from CNET user

This email was sent from the 'Request for permission form' at
<http://www.cnet.com/html/aboutcnet/editorial/form.html>

name Nick Bonatsakis

company student

email: nick718@wpi.edu

phone 8603240264

what other

url several URLs

where other

purpose: I represent a group of students at Worcester Polytechnic Institute in MA. We are putting together a museum exhibit on the history of storytelling in games. We are planning an interactive portion to our exhibit, that will feature many video clips. Many of these clips will be of our own gameplay, however we would really like to include many of the Gamespot.com features on the history of game series, as well as several interviews. This exhibition is non-profit, and the videos will be unaltered, thus ensuring advertising for Gamespot.com id

2 submit submit

Please address any questions about this email to sparta-ops@cnet.com

Ankarino

.....

Ankarino Lara | *Director, Product Development*

235 2nd Street, SF CA 94105

Appendix 9: Labels

The following is a listing of all the case labels as they will appear in the exhibit. They have all been sized down to a font size of 12 in order to save space in this document. The actual labels have been printed in Jolt Wide font in the proper font size. They were mounted on various types of poster board as described in the Procedure section. They, along with the wall text, will be stored in the Gordon Library until the time of the exhibition.

Case A

Star Trek vol. 4, 1976
People's Computer Company
Newsprint Tabloid

Adventure, 1978
Atari
Videogame for Atari VCS

Adventureland, S.A.G.A, 1979
Adventure International
Software for Apple II

These games were some of the first to incorporate a story in which the player could choose his own path or direction. The storyline became such a smash hit that it was quickly developed for several consoles and computers available at the time.

Savage Island, 1982
Adventure International
Software for Apple II

This text-parsing game incorporated basic graphics with the intention to make the plot more immersive to the player.

Wizardry: A Game of Fantasy and Adventure, 1981
Sir-Tech Software
Manual

Wizardry: Proving Grounds of the Mad Overlord, 1981
Sir-Tech Software
Software for Apple II

The first in a series of Wizardry games by Sir-Tech Software, this text-parsing game was inspired by the Dungeons and Dragons fantasy role-playing game. It allowed the player to explore the game world through a first person perspective.

Upper Reaches of Apshai, 1981

Automated Simulations / Epyx

Software for TRS-80 or Atari 400/800 computer

This is an expansion pack for *The Temple of Apshai* (1980, Epyx Software), a role-playing, treasure-seeking game that used detailed text and graphics to immerse the player.

Castle Wolfenstein, 1981

Muse Software

Software for Apple II

This was the first game to include sampled speech. It also utilized an overhead view of the action instead of common two-dimensional side-scrolling, popular in arcades and consoles of that time.

The Art of Computer Game Design, 1982

Chris Crawford

Draft manuscript (first rev.)

“The central premise of this book is that computer games constitute a new and as yet poorly developed art form that holds great promise for both designers and players.” --
Chris Crawford (Preface)

The full text is available online at

<http://www.vancouver.wsu.edu/fac/peabody/game-book/Coverpage.html>

Case B

Donkey Kong, 1982

Coleco Industries / Nintendo

Software for Colecovision

A console port of the Donkey Kong arcade game, this was the first game to use the “save the princess” theme that would continue to be included in countless other titles. It also featured the first appearance of “Jumpman”, who would later be known as Mario.

Star Wars: Jedi Arena, 1983

Lucasfilm / Parker Brothers

Videogame for Atari VCS

Star Wars: The Empire Strikes Back, 1983

Lucasfilm Games

Videogame for Atari VCS

Mario Bros., 1983

Nintendo

Software for Atari 5200 Supersystem

A console port of the Mario Bros. arcade game, this was the first game to feature Mario as the main character. It started arguably the most famous video storyline of all time by introducing Mario as a plumber with a brother named Luigi.

Mindwheel, 1984

Brøderbund

Software for Commodore 64 or DOS

Dubbing itself “an electronic novel,” this text-only game came packaged with a 70-page instruction manual that detailed scenes happening in the game.

Case C

King's Quest, 1984

Sierra On-Line/Konami

Software for IBM PC

This is an example of one of the earliest graphical text-parsing adventure games. The game allowed the player to control the character on screen. It is often referred to as the first interactive cartoon.

Ballblazer, 1985

Epyx Inc.

Software for Apple II

Star Wars, 1985

LucasFilm Games

Videogame for NES

An early side-scrolling game based off the popular Star Wars movies.

Wizard's Crown, 1985
Strategic Simulations, Inc.
Software for Apple II

Mind Mirror, 1985
Electronic Arts
Software for Commodore 64

Ultima I, 1980/1986
Origin Systems, Inc.
Software for IBM PC
Case D

Gauntlet, 1985
Tengen
Videogame for NES

Super Mario Brothers, 1985
Nintendo
Videogame for NES

This game turned the video game industry around after the massive video game crash of 1983. It successfully combined the “save the princess” theme, side-scrolling environment, and cutting edge graphics to create a smash hit.

The Legend of Zelda, 1987
Nintendo
Videogame for NES

A hit NES game that was based off the “save the princess” theme. Its enticing storyline along with RPG game elements made it an instant success which spawned numerous sequels.

Pool of Radiance, 1988
Strategic Simulations, Inc.
Software for Commodore 64

Neuromancer, 1988
Interplay Productions
Software for Commodore 64

Flyer for Essex MUD, 1989
Unknown
Digital Facsimile

“Explore Fantastic new Worlds of Computer Gaming”, 1989
Strategic Simulations, Inc.
Product Catalog

Metal Gear, 1989
Ultra Software Corporation
Software for IBM PC
Case E

Maniac Mansion, 1990
Jaleco
Videogame for NES

This was one of the first role-playing games to use only a pointer. Unlike computer games of its kind, it made gameplay less about guessing text commands and more about figuring out the story.

DragonStrike, 1990
Strategic Simulations Inc.
Videogame for NES

This game was an early example of a storyline being the primary selling point of a game. Followers of the popular DragonLance series bought this game solely on the fact that it expanded upon the storyline.

Secret of the Silver Blades, 1990
Strategic Simulations Inc.
Software for PC

The Way of the Avatar (A Guide to Ultima IV), 1990

Origin Systems Inc.

Booklet

Ultima IV, 1990

Origin Systems Inc.

Software for PC

Secret Weapons of the Luftwaffe, 1991

Lucas Arts

Demo Software for PC

Super Mario World, 1991

Nintendo

Videogame for SNES

One of the most successful Mario games ever, this game continued the Mario storyline. It expanded the character base to include the character Yoshi, who would later go on to spawn another series of games.

Case F

Wolfenstein 3D, 1992

Id Software

Software for PC

This game started a revolution of first person shooters which was a massive blow to storytelling in gaming. First person shooters took the gaming community away from story and brought them closer to action.

The Terminator, 1992

Mindscape

Videogame for NES

The Legend of Zelda: A Link to the Past, 1992

Nintendo

Videogame for NES

King's Quest V, 1992

Sierra On-Line/Konami

Videogame for NES

Wolfenstein, 1993
Id Software
Videogame for NES

Full Throttle, 1994
Lucas Arts
Mac Software

A landmark success for Lucas Arts, this game became a success because of the very skilled writers behind the game. The film-quality plot contained murder, deception, greed, lust, love, and honor - an usually rich plot for video games of its time.

Case G

Star Wars: Tie Fighter, 1996
Lucas Arts
Demo Software for PC

This game took a unique approach to storytelling by focusing on the path of a character that would in the Star Wars universe be considered an antagonist.

Afterlife, 1996
Lucas Arts
Demo Software for PC

Mortimer and the Riddles of the Medallion, 1996
Lucas Arts
Demo Software for PC

Half-Life, 1998
Valve/Sierra
Software for PC

This game represented a significant leap in both gameplay and storytelling. Specifically, it moved the plot along smoothly with very few cut scenes and an emphasis instead on dialog.

Escape from Monkey Island, 2000

Lucas Arts

Demo Software for PC

A fine example of using humor to portray a story, this game was a sequel to several earlier installments that used the same theme.

Asheron's Call: Dark Majesty, 2002

Microsoft

Software for PC

Indiana Jones and the Temple of Doom, 2003

Lucas Arts

Demo Software for PC

Star Wars Galaxies: An Empire Divided, 2003

Lucas Arts

Software for PC

This was the first massively multiplayer online role-playing game based on the Star Wars universe. It featured the ability to make characters and explore settings familiar to fans of the movies.

Wall Text

The following are the text segments used on the Wall Text.

“*Star Wars: Knights of the Old Republic* is not only providing one of the very best interactive Star Wars experiences, but it has tapped into the very soul of the Star Wars universe that drew hundreds of millions of fans to the franchise in the first place” – Aaron Boulding

“Through a series of subtle and artistic design decisions, *Half-Life* creates a reality that is self-contained, believable, and thoroughly engaging” – Ron Dulin

“Having taken advantage of PS2's new technology to expand and develop their vision, the makers of *Grand Theft Auto 3* have created a complete videogame experience like few, if any, before it” – Douglas Perry

Wolfenstein 3D opened the door for a revolution of first person shooters and at first this was a massive blow to storytelling in gaming. "Part of Wolf3D's appeal is in its simplicity: it is all about firepower, not brainpower" - Kevin Bowen

Appendix 10: Catalog

Due to the fact that we did not receive the actual artifacts before the end of our project time, it was impossible to create a complete catalog. We have however created a template/framework for a subsequent final catalog. This template/frame can be found on the enclosed DVD-R in a folder called "Catalog". To open the Catalog in a web browser, simply double click the "Home.htm" file.