

**FHS PUBLIC ACCESS**

Author manuscript

Am J Med Genet. Author manuscript; available in PMC 2017 June 29.

Published in final edited form as:

Am J Med Genet. 1984 May ; 18(1): 61–65. doi:10.1002/ajmg.1320180110.

Linkage Analysis in a Large Kindred With Autosomal Dominant Transmission of Polyglandular Autoimmune Disease Type II (Schmidt Syndrome)

Merlin G. Butler, M.E. Hodes, P.M. Conneally, Angenieta A. Biegel, and James C. Wright

Departments of Medical Genetics (M.G.B., P.M.C., M.E.H.), Medicine (A.A.B., M.E.H.), and Pediatrics (J.C. W.), Indiana University School of Medicine, Indianapolis

Abstract

Schmidt syndrome (PGA syndrome type II) is a rare condition characterized by polyglandular failure. It is an autosomal dominant trait with variable expressivity that was inherited over four generations in an Indiana kindred. Association of HLA-B8 has been reported with Schmidt syndrome. Our proband is a 12-year-old boy with Addison disease, insulin dependent diabetes mellitus (IDDM), and vitiligo. Two of his eight sibs had either IDDM (sister) or vitiligo and hyperthyroidism (brother). His mother had hypothyroidism. Seven members of earlier generations apparently were also affected. We obtained peripheral blood for HLA and genetic analysis from 21 relatives in a family with 8 Schmidt syndrome individuals in three generations. HLA studies on 15 affected and unaffected relatives showed only 2 of 7 persons with B8-containing haplotypes. Therefore, no association exists between the B8-containing haplotype and the syndrome.

We identified informative marker loci. No evidence for linkage of the Schmidt locus to any of the 14 markers was found and close linkage to esterase D and adenylate kinase and possibly properdin factor B was excluded.

Keywords

Schmidt syndrome; autosomal dominant; HLA association; genetic linkage; polyglandular autoimmune syndrome type II

Introduction

After Schmidt [1926] described two patients with nontuberculous Addison disease and chronic lymphocytic thyroiditis, the association of these two disorders was increasingly recognized. Carpenter et al [1964] reviewed the condition and added 15 new cases. Several of these individuals also had diabetes mellitus. By 1981, it was clear that the condition described by Schmidt was autoimmune in nature, involved several endocrine glands (adrenal, thyroid, pancreas, gonads) and other tissues, and could be divided into three types [Neufeld et al, 1980, 1981]: PGA (polyglandular autoimmune syndrome) type I,

characterized by Addison disease, hypoparathyroidism, and chronic mucocutaneous candidiasis with alopecia, malabsorption syndrome, gonadal failure, pernicious anemia, and chronic active hepatitis as decreasingly frequent concomitants; PGA syndrome type II: Addison disease, autoimmune thyroid disease (69%), insulin-requiring diabetes mellitus (52%), and neither hypoparathyroidism nor chronic mucocutaneous candidiasis; and, PGA syndrome type III in which Addison disease is absent but autoimmune thyroid disease is accompanied by another autoimmune dysfunction.

Several additional characteristics of PGA syndrome type II deserve note. The adrenal failure generally appears after 10 years and the peak age-of-onset is between 20–40 years. A number of authors [Thomsen et al, 1975; Eisenbarth et al, 1978, 1979; Neufeld et al, 1981] noted striking increases of HLA-A1 and HLA-B8 antigens in some patients, whereas others [Anderson et al, 1980] did not find the HLA association. Only four families of individuals with PGA syndrome type II have been published [Eisenbarth et al, 1978, 1979; Anderson et al, 1980; Farid et al, 1980]. We report here a large kindred with apparent autosomal dominant inheritance of PGA syndrome type II, the first report of a family with clear evidence of this mode of transmission.

Methods

Patients

Patient 1, the proband, was 10 4/12 years old when first seen. He developed asthma and nephrotic syndrome characterized by edema and proteinuria at 5 years, insulin dependent diabetes mellitus at 6 years and vitiligo at 9 years. At that time he began to have frequent insulin reactions and a decreased insulin requirement. At 10 years he had “flu” and shortly afterwards was admitted because of dizziness, nausea, and vomiting. His blood pressure and urine output decreased and he became unresponsive. Hyponatremia and hyperkalemia were found and the diagnosis of Addison disease was made. He was then transferred to our medical center. Treatment included NPH Insulin^R, Florinef^R, and Cortef^R.

Physical examination showed a well-built, muscular, 10-year-old boy with height and weight at the 50th percentile. There was a hypopigmented area above the right eyelid and hypopigmented areas were seen on the fingertips and toes. The rest of the skin was bronzed with pigmented dermal creases and there was a cafe-au-lait spot on the right thigh. There was a short uvula and increased carrying angle of the arms.

Patient 2 (IV-6) is the 20-year-old sister of the proband. She has had diabetes mellitus since age 3 years and reportedly had kidney infections. She was pregnant at the time of examination.

Patient 3 (IV-9) is the 16-year-old brother of the proband. He has had hyperthyroidism from age 10 years and hypopigmentation of the legs and arms since age 3 years. He has no signs of hyperpigmentation at present.

Patient 4 (III-11) is the proband's mother. She is 44 years old and has been receiving medication for hypothyroidism of unknown etiology for the past 7 years. She is normal physically and is asymptomatic.

Patient 5 (II-5) is the proband's maternal grandfather. He had vitiligo since childhood and died from a "stroke." There was no history of other endocrine failure.

Patient 6 (II-3) is the proband's maternal great aunt. She is 71 years old and has had hypopigmentation of the legs, feet, hands and abdomen since age 7 years and noninsulin dependent diabetes mellitus for the past 10 years. She also has asthma but no other signs of endocrine failure.

Patient 7 (II-10) is the proband's maternal great aunt. She is 61 years old and has had hypopigmentation of the legs, arms, hands and upper torso since age 29 years and has been receiving medication for pernicious anemia for the past 6 years. She also has asthma and arthritis but no other signs of endocrine failure.

Patient 8 (II-12) is the proband's maternal great aunt. She is 56 years old and has had hypopigmentation of the hands for the past year. She has been receiving medication for hypothyroidism of unknown etiology since age 38 years. She had asthma as a child but no other signs of endocrine failure.

Patient 9 (III-19) is patient 8's son. He is 29 years old and has had hypopigmentation of the hands since age 26 years. He has gastric ulcers but no other physical abnormalities.

Other relatives and their disorders are shown in Figure 1. The proband's maternal great grandfather and great great aunt had pernicious anemia but no other physical abnormalities; therefore the Schmidt syndrome gene was inherited from the grandfather in this family. Several family members at risk for Schmidt syndrome have only noninsulin dependent diabetes mellitus and were not considered to have Schmidt syndrome. All other relatives were considered normal.

Linkage Analysis

We typed 21 individuals, including 8 with Schmidt syndrome, in three generations for 17 marker loci and HLA-A, B, and C in an attempt to localize the gene. Four of these loci, Kell, ACPI, ADA and GC were not informative for linkage. The remaining 14 loci were analyzed for linkage using the computer program LIPED [Ott, 1974]. Inspection of the family suggested an approximate penetrance of 70%, which was included in the linkage analysis. The markers, chromosomes on which they reside, and lod scores at different recombination fractions are shown in Table I.

Results

There is no evidence for linkage of the Schmidt locus to any of the 14 informative markers; a lod score less than -2.0 is taken as sufficient evidence for rejecting the hypothesis of linkage [Morton, 1955]. Linkage to esterase D (ESD) and adenylate kinase (AK) can be

rejected at a recombination fraction of 5% or less. Linkage to properdin factor B (BF) is close to rejection at a recombination fraction of 5% or less.

Because of the reported association of HLA and the Schmidt syndrome, it is of interest to note the lod scores for HLA as well as other markers on chromosome 6. The highest lod score for HLA was 0.15 at 30% recombination fraction and the lowest lod score was -0.42 at 5% recombination. This evidence does not support linkage to HLA; however, we cannot exclude this marker with a lod score of -0.42 .

Discussion

The polyglandular autoimmune disorders are now well characterized. Our proband fits well into the PGA syndrome type II classification of Neufeld et al [1980, 1981] although he has not (yet) developed thyroid disease. His mother and a sib do have thyroid involvement and other relatives have one or more manifestations of PGA syndrome type II. The proband probably first showed manifestations of the disease at age 6 years but other relatives had variable ages of onset between childhood and 38 years. The variability in age of onset and expressivity has been noted by others [Eisenbarth and Lebovitz, 1978; Eisenbarth et al, 1978, 1979; Anderson et al, 1980; Farid et al, 1980; Wirfalt, 1981].

HLA association has been reported for PGA II but not for PGA I. Eisenbarth et al [1978, 1979] found a close association with HLA-A1 and HLA-B8. Farid et al [1980] found this association to hold in some but not all families. The family reported on by Anderson et al [1980] and our family failed to show such association.

The size ($N = 37$) and cooperativeness of our family permitted us to seek linkage of PGA syndrome type II with other markers. This led to exclusion of AK and ESD and possibly BF at close linkage, and no evidence for linkage was found with HLA or 13 other informative markers.

The inheritance of PGA syndrome type II, and indeed the other PGA syndromes, has been unclear. Various modes of inheritance of PGA syndromes have been suggested. Confusion in genetic analysis may have resulted from the confounding of the various PGA syndrome types. In our family, inheritance is clearly autosomal dominant type with reduced penetrance, variable expressivity and male-to-male transmission (Fig. 1). The family of Anderson et al [1980] suggested polygenic determination although nonpenetrance in the common father may have been responsible for the inheritance pattern.

We think that PGA syndrome type II, which is segregating in our family, may itself be heterogeneous in origin. Families such as the one presented here represent autosomal dominant inheritance and reduced penetrance and no association with specific HLA-A or B haplotypes.

References

- Anderson P, Fein S, Frey W. Familial Schmidt's syndrome. JAMA. 1980; 244:2068–2070. [PubMed: 7431539]

- Carpenter CCJ, Solomon N, Silverberg SG, et al. Schmidt's syndrome (thyroid and adrenal insufficiency): A review of the literature and a report of fifteen new cases including ten instances of coexistent diabetes mellitus. *Medicine*. 1964; 43:153–180. [PubMed: 14132718]
- Eisenbarth G, Wilson P, Ward F, Lebovitz HE. HLA type and occurrence of disease in familial polyglandular failure. *N Engl J Med*. 1978; 298:92–94. [PubMed: 619238]
- Eisenbarth G, Lebovitz H. Immunogenetics of the polyglandular failure syndrome. *Life Sci*. 1978; 22:1675–1683. [PubMed: 580945]
- Eisenbarth G, Wilson P, Ward F, Buckley C, Lebovitz H. The polyglandular failure syndrome: Disease inheritance, HLA type and immune function. *Ann Intern Med*. 1979; 91:528–533. [PubMed: 314765]
- Farid N, Larsen B, Payne R, Noel E, Sampson L. Polyglandular autoimmune disease and HLA. *Tissue Antigens*. 1980; 16:23–29. [PubMed: 7008251]
- Morton NE. Sequential tests for the detection of linkage. *Am J Hum Genet*. 1955; 7:277–318. [PubMed: 13258560]
- Neufeld M, MacLaren N, Blizzard R. Autoimmune polyglandular syndromes. *Pediatr Ann*. 1980; 9:154–162. [PubMed: 6990358]
- Neufeld M, MacLaren N, Blizzard R. Two types of autoimmune Addison's disease associated with different polyglandular autoimmune (PGA) syndromes. *Medicine*. 1981; 60:355–362. [PubMed: 7024719]
- Ott J. Estimation of the recombination fraction in human pedigrees: Efficient computation of the likelihood for human linkage studies. *Am J Hum Genet*. 1974; 26:588–597. [PubMed: 4422075]
- Schmidt MB. Eine Biglanduläre Erkrankung (Nebennieren und Schilddrüse) bei Morbus Addisonii. *Verhandl Deutsch Path Gesellsch*. 1926; 21:212–221.
- Thomsen M, Platz P, Andersen O, Christy M, Lyngsoe J, Nerup J, Rasmussen K, Ryder L, Nielsen L, Svejgaard A. MLC typing in juvenile diabetes mellitus and idiopathic Addison's disease. *Transplant Rev*. 1975; 22:125–147. [PubMed: 46642]
- Wirfalt A. Genetic heterogeneity in autoimmune polyglandular failure. *Acta Med Scand*. 1981; 210:7–13. [PubMed: 7293829]

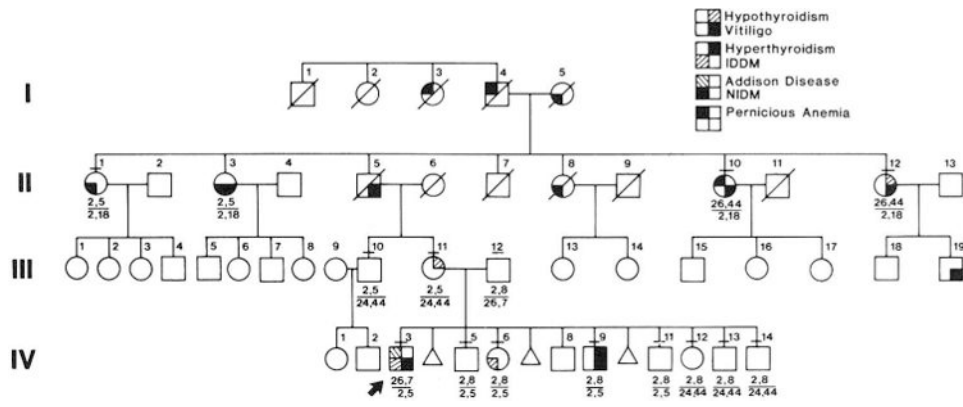

Fig. 1. Pedigree of Schmidt syndrome family. Examination of the individual indicated by a bar over the symbol denoting the case. The HLA A and B haplotypes, e.g. (A₂,B₅)/(A₂,B₁₈) are indicated under the symbols for male (□) or female (○). □, Ø male, female (deceased).

Author Manuscript

Author Manuscript

Author Manuscript

Author Manuscript

Table 1
Lod Scores Between the Schmidt Syndrome Locus and 14 Marker Loci

Marker	Chromosome	Recombination fraction						
		0.0	0.05	0.10	0.20	0.30	0.40	
RH	1	-∞	-1.01	-0.50	-0.10	0.02	0.02	
FY	1	-∞	-0.88	-0.52	-0.19	-0.05	-0.01	
PGM1	1	-∞	-1.08	-0.61	-0.21	-0.06	-0.01	
MNS	4	-∞	-1.16	-0.63	-0.23	-0.11	-0.06	
P	6	-0.15	-0.12	-0.09	-0.05	-0.02	-0.01	
BF	6	-∞	-1.86	-1.35	-0.70	-0.29	-0.07	
GLOI	6	-0.09	0.05	0.17	0.30	0.28	0.17	
HLA	6	-∞	-0.42	-0.03	0.28	0.33	0.22	
KIDD	7	-∞	-1.30	-0.89	-0.48	-0.26	-0.11	
ABO	9	0.64	0.59	0.54	0.42	0.30	0.16	
AK1	9	-∞	-2.03	-1.51	-0.78	-0.34	-0.10	
ESD	13	-∞	-2.21	-1.50	-0.85	-0.49	-0.22	
HP	16	-∞	-1.43	-0.99	-0.49	-0.20	-0.04	
GPT1	16	-∞	-0.34	-0.11	0.04	0.05	0.02	