

Spring 1993

## Focal Spot, Spring 1993

Follow this and additional works at: [http://digitalcommons.wustl.edu/focal\\_spot\\_archives](http://digitalcommons.wustl.edu/focal_spot_archives)

---

### Recommended Citation

Focal Spot, Spring 1993, April 1993. Bernard Becker Medical Library Archives. Washington University School of Medicine.

This Book is brought to you for free and open access by the Focal Spot at Digital Commons@Becker. It has been accepted for inclusion in Focal Spot Archives by an authorized administrator of Digital Commons@Becker. For more information, please contact [engeszer@wustl.edu](mailto:engeszer@wustl.edu).

SPRING, 1993

VOLUME 24, NUMBER 1

# FOCAL SPOT

MALLINCKRODT INSTITUTE OF RADIOLOGY

Indexed

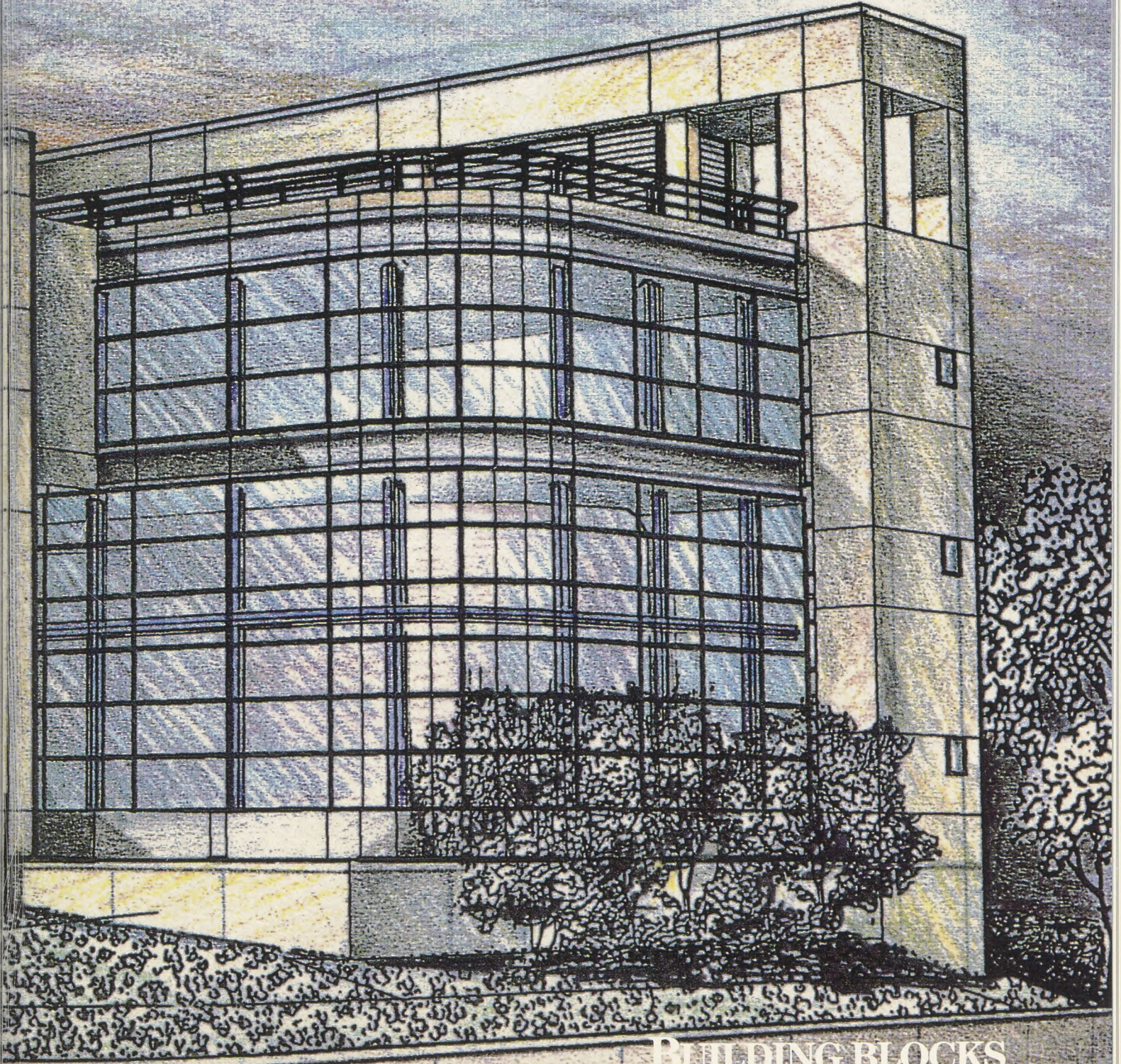

BUILDING BLOCKS  
FOR IMAGING THE MIND

## Spiral CT Arteriography

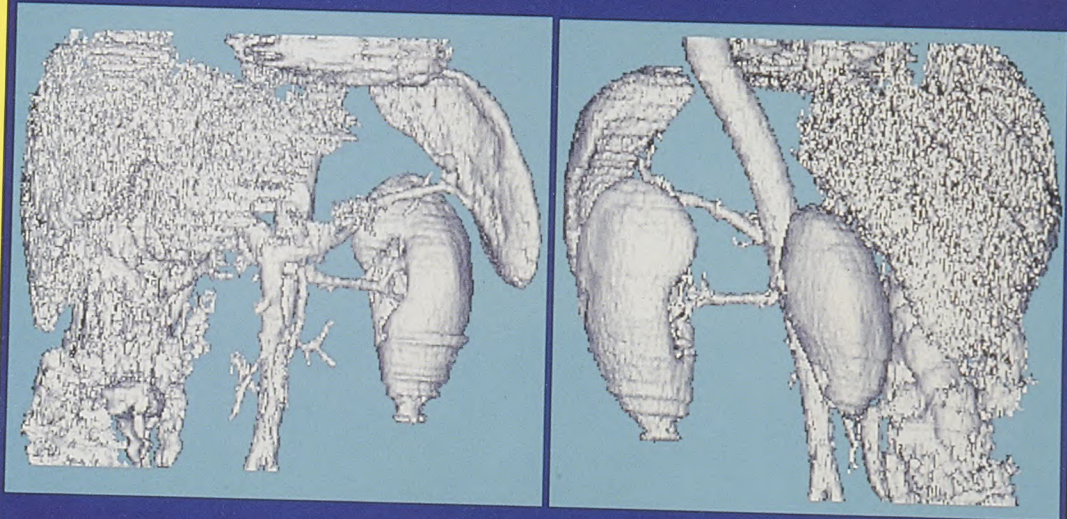

*Spiral computed tomography (CT) is noninvasively producing information that rivals data obtained from other diagnostic procedures. The three-dimensional image above defines the abdominal aorta and major vessels, including the left renal artery. For more information on spiral CT studies at MIR, please turn to page 12.*

# FOCAL SPOT

SPRING, 1993

VOLUME 24, NUMBER 1

MALLINCKRODT INSTITUTE OF RADIOLOGY

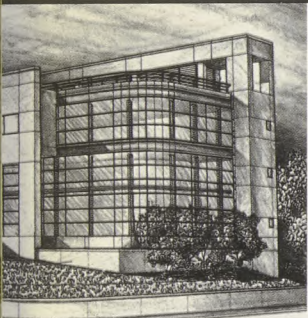

## 6 BUILDING BLOCKS FOR IMAGING THE MIND

MIR researchers have made dynamic contributions in imaging the functions of the brain, but the human mind with its ability to control our thoughts, emotions, and reasoning has remained uncharted. Now with the construction of a comprehensive neuroimaging center at the Institute, scientists hope to solve the mysteries of the mind.

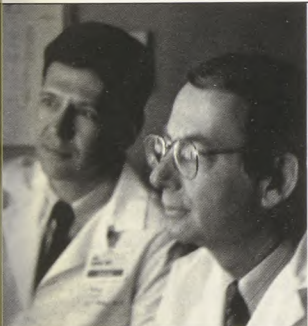

## 12 FILLING IN THE GAPS WITH SPIRAL CT

More than 20 years ago, Sir Godfrey Hounsfield came to Mallinckrodt Institute seeking information about the clinical application for a technology he had developed — computed tomography (CT). With the arrival in the past two years of a newer, faster version of CT, physicians at MIR are conducting a large-scale study to evaluate the benefits of spiral CT.



## 18 ELECTRONIC RADIOLOGY: THE DIGITAL DREAM

The transfer of medical images from one piece of equipment to another has long been a problem for hospitals because each equipment manufacturer had its own method of storing the information. MIR's Electronic Radiology Laboratory developed a software package that solved the problem.



## 2 SPOT NEWS

## 24 FYI

## 32 REFLECTIONS

**MIR**  
MALLINCKRODT  
INSTITUTE OF RADIOLOGY  
WASHINGTON UNIVERSITY  
MEDICAL CENTER

### ON THE COVER:

*The neuroimaging center at Mallinckrodt Institute's East Building will be up and running by mid-1994. The center will provide a centralized location for multi-departmental collaboration on studies of the mind. Artist's rendering courtesy of the architectural firm of Stone Marraccini & Patterson.*

# SPOT NEWS



## Mackey Earns FIRST Award

Michael A. Mackey, Ph.D., assistant professor of radiology, received a \$350,000 grant from the National Institutes of Health for his proposed study, "Mechanisms of Cell Killing During 41.5°C Hyperthermia." The grant comes under the umbrella of a First Independent Research Support and Transition (FIRST) Award, which is presented to researchers who have received no other major grants and are in the first five years of their careers.

Hyperthermia, in some form of its many incarnations, has been used to treat tumors for over 4,000 years. In modern times, the earliest documented usage of hyperthermia, or heat therapy, dates back to 1866. Sporadic studies were reported up until 1940 when hyperthermia

was overshadowed by the widespread use of radiation therapy. The revival of hyperthermia research at Mallinckrodt Institute began in 1979, and researchers in the Radiation Oncology Center's Cancer Biology Section continue to investigate the effects of hyperthermia at the cellular and molecular levels.

Clinical hyperthermia uses high temperatures to kill cancer cells, with 43°C as the treatment temperature goal. Because of the difficulty patients can experience in tolerating the higher heat levels, as well as the technical difficulties associated with heat delivery systems, investigators began to study the effects of more moderate temperature elevations on tumor cells. Historically, rodent cells were used in an attempt to measure biochemical events occurring in the cellular life cycle. It is now clear that there may be substantial differences between the responses of rodent and human cells to moderate hyperthermia.

### *Michael A. Mackey, Ph.D.*

According to Mackey, "Cells normally have mechanisms that control events in their life cycle. After a cell divides, it must double all its DNA before it can divide again, and there are elaborate biochemical mechanisms in place to prevent premature cell division. We have found that human cells heated at forty one point five degrees Celsius die because they try to divide before finishing replication of their DNA."

Mackey's research was conducted initially through a joint program at the University of California at Berkeley and at San Francisco. Preliminary findings revealed that rodent cells encounter an initial killing period at 41.5°C, followed by a plateau in cell killing. Based on numerous study results and the assumption that human cells reacted similarly to the rodent cells, the medical and biophysical communities recommended that no temperatures lower than approximately 43°C be used in clinical hyperthermia.

Mackey challenged that assumption and discovered that at 41.5°C, human cells do not encounter a plateau — cell killing continues. Why the difference between the two types of cells?

"It has to do with how the cells are affected in their life cycle," says Mackey. "The rodent cells are halted in their life cycle; human cells slow down but continue to move. Eventually, the human cell attempts to divide precociously, a process that leads to cell death. Our goal is to understand the biochemical basis for such premature cell division."

The research team is evaluating a battery of biochemical techniques, involving computer and mathematical modeling, to generate experimentally testable hypotheses. Technically, the five-year study is a basic science grant for providing researchers with an understanding of why temperature elevation can disrupt regulation of the cell growth cycle. But Mackey says that the investigation also will assist clinicians in determining the optimal therapeutic temperature for both significant cell killing and patient tolerance.

## Additional Funding for Brachytherapy Dosimetry Study

The National Cancer Institute (NCI) has awarded a \$155,387 per year renewal grant to Jeffrey F. Williamson, Ph.D., chief of the brachytherapy physics group in MIR's radiation physics section, for his study of "Heterogeneity Corrections in Brachytherapy Dosimetry." The grant, originally awarded in 1989, is now entering the second phase of a seven-year project.

Williamson and coinvestigators Perry W. Grigsby, M.D.; Vivek Mishra, Ph.D.; Ali Soleimani-Meigooni, Ph.D.; and Zuofeng Li, D.Sc., will further their study of dose distribution variations resulting from differences in density and composition of tissues treated with brachytherapy.

# SPOT NEWS

## Prosthetic Fittings More Efficient with 3-D Imaging

Funded by a U.S. Public Health Service grant, Michael W. Vannier, M.D., professor of radiology, director of the Division of Radiology Research, and head of the image processing lab, is using three-dimensional imaging techniques to improve the procedure by which prostheses are fitted. Software used to produce computer-generated models of prostheses is hampered by the insufficient data supplied by current methods of measuring the remaining limb's shape, volume, or tissue characteristics. However, anatomic three-dimensional reconstruction, using a 3-D optical surface scanner and spiral computed tomography, can clearly define the surface geometry and the hard and soft tissue of the limb.

By interfacing these 3-D imaging modalities, Vannier and coinvestigators Paul Commean, B.E.E., research engineer; Gulab Bhatia, M.S., research associate; Kirk Smith, A.A.S., research engineer; Thomas Pilgram, Ph.D., research associate; James Cheverud, Ph.D., professor of anatomy and genetics; and Robert Knapp, B.M., R.T., technical supervisor, plan to build and validate a new process to quantify prosthetic fittings. The research team will collaborate with O & D Lab, Inc., a local manufacturer of custom prost-

hetics and orthotics that has an office in the Irene Walter Johnson Rehabilitation Institute at the Washington University Medical Center.

The two-year grant of \$452,560 was awarded by the National Institute of Child Health and Human Development, a division of the U.S. Department of Health and Human Services.

## NCI Grant Renewed

Joseph L. Roti Roti, Ph.D., professor of radiology, associate director of the Radiation Oncology Center, and chief of the cancer biology section, was awarded a five-year competing renewal grant from the National Cancer Institute for the study of "Radiation-induced Alterations of Chromosomal Proteins." Funding in the amount of \$603,388 will allow Roti Roti and his team of MIR investigators to study radiation effects on nuclear proteins in mammalian cells.

Cells have a natural "feedback pathway" that verifies if all mechanisms are in place for natural cell division — most importantly, the completion of DNA replication and the detection of radiation damage to DNA. These pathways are part of the cell's intrinsic resistance to radiation and, subsequently, reduces or alters the effectiveness of radiotherapy.

According to Roti Roti, interpreting these checkpoint pathways has important implications: understanding the basic control of the cell cycle (or cell-cycle delay) will provide an insight into the cell's awareness of its internal milieu as well as the

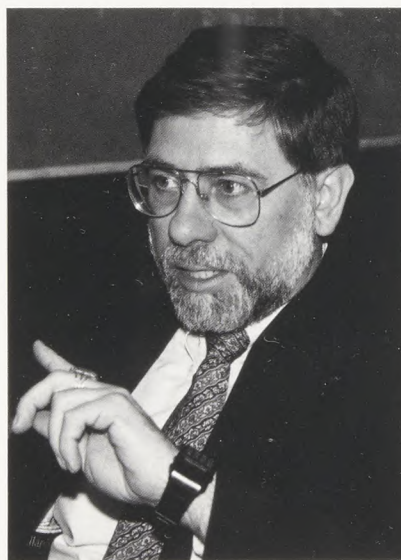

*Joseph L. Roti Roti, Ph.D.*

contribution of this phenomenon to the radio-resistance or sensitivity of cells.

Researchers will use mammalian cells grown *in vitro* and obtained from the appropriate cell-cycle stage by one of two methods — synchronization by the mitotic collection method (developed by the late Leonard J. Tolmach, Ph.D., professor emeritus of radiation biology at MIR) or by cell sorting.

Preliminary studies for the grant revealed that the protein Topoisomerase II, which is involved in DNA supercoiling changes and whose synthesis is specifically altered in irradiated cells, may be one of a group of nuclear proteins believed to play a role in radiation-induced cell-cycle delays. In particular, Roti Roti and coinvestigators Ryuji Higashikubo, Ph.D.; Yvonne C. Taylor, Ph.D.; Clayton R. Hunt, Ph.D.; Andrei Laszlo, Ph.D.; Prabhat Goswami, Ph.D.; and William D. Wright, B.S., will test this hypothesis by measuring synthesis of the protein in the radiation-induced checkpoint pathway

known as G<sub>2</sub>-block where cells rest just prior to mitosis. When the pathway is satisfied that DNA has been returned to the proper state for division, then the natural cell cycle begins.

This project encompasses many of the fundamental ways in which radiobiology relates to radiotherapy, particularly the four aspects recognized by radiation oncologists: repair, redistribution, reoxygenation, and repopulation of cells. Although the correlation of radiobiology to radiotherapy has been known for the past 30 years, Roti Roti says that no clinician or radiobiologist has been able to effectively manipulate the biology of tumors or to alter the response to cell killing.

"In radiotherapy, radiobiology has to occur," says Roti Roti. "One can have all the physics and all the imaging, but it comes down to the fact that humans are biological creatures and the way human tumor cells respond to radiotherapy is a biological response."

# SPOT NEWS

## MIR Faculty Lend Editorial Expertise to Journals

Three MIR faculty recently accepted positions on the editorial boards of nationally and internationally recognized scientific publications. Jeffrey J. Brown, M.D., assistant professor of radiology and chief of magnetic resonance imaging, was appointed as associate editor to the board of *Radiology*, a leading scientific journal that is devoted to clinical radiology and the allied sciences. Andrei Laszlo, Ph.D., assistant professor of cancer biology, was invited to join the editorial board of the *International Journal of Hyperthermia*, one of the foremost publications for radiation oncology clinicians and scientists involved in the field of hyperthermia. Michael W. Vannier, M.D., professor of radiology, director of the Division of Radiology Research, and head of the image processing lab, is a member of the editorial board for ECOMED Fachverlag's *Minimal Invasive Medizin*, a premier European medical journal.

Also, because of the consistently high quality of his reviews, James A. Brink, M.D., was presented with *Radiology's* "Editor's Recognition Award for Distinction in Reviewing," according to Stanley S. Siegelman, M.D., editor of the journal.



## MIR Alum Delivers Seventh Biello Lecture

Richard L. Wahl, M.D., a former MIR diagnostic and nuclear radiology resident, returned to the Institute on February 8, 1993, to present the Annual Daniel R. Biello Memorial Lecture. The lectureship honors the life and research of Daniel Biello, a nationally recognized MIR nuclear medicine scientist who died in 1986 from Hodgkin's disease.

Wahl has developed an expansive oncologic research program at the University of Michigan Medical Center in Ann Arbor where he is a professor of internal medicine and radiology. He is a 1978 graduate of Washington University School of Medicine and has received numerous honors recognizing his contributions to radiology and nuclear medicine, including the prestigious Berson-Yalow Award of the Society of Nuclear Medicine and recent appointment as a trustee of the American Board of Nuclear Medicine.

*Richard L. Wahl, M.D. (left), and Barry A. Siegel, M.D., director of MIR's Division of Nuclear Medicine*

Speaking in Scarpellino Auditorium on the "New Horizons in Oncologic Nuclear Medicine," Wahl outlined the future role of nuclear medicine in cancer management. "Most of conventional radiology looks at a very high quality of anatomy," he said, "but with tumors, it's basically mass or no mass. And with nuclear medicine capabilities, we are finding some lesions that are not detectable by conventional imaging modalities."

Citing cases from University of Michigan Medical Center studies of colorectal, lung, breast, and bladder cancer as well as melanoma and lymphoma, Wahl discussed the targeting of radiolabeled antibodies to CEA-producing tumors. "Absolute delivery of antibodies to tumors is lower than we would like for diagnosis and therapy," he said. "That has been a major limitation of progress in the field. We must present higher levels of antibodies to the tumor, forcing an equilibrium toward binding to the tumor."

Wahl is a leader in the fight for multicenter trials for positron emission tomography (PET) in oncology, and he discussed the goals of PET in tumor imaging, specifically in breast cancer:

- to use fluorodeoxyglucose (FDG) and PET to assess sequentially the changes in FDG uptake into large primary breast cancers being treated with an acute chemo-hormono therapy program

- to correlate short- and long-term clinical response with early changes on PET scan
- to determine if PET scanning can serve as an *in vivo* indicator of tumor response to treatment at early time points, at post-initiation of treatment, or prior to morphologic changes occurring
- to determine if PET scanning ultimately can serve as a guide to aid in cancer treatment planning.

He concluded his talk by saying that the future of nuclear medicine in cancer management shows promise — in diagnosis by using more monoclonals, more PET with regional FDG distribution, and more peptides; and in therapy with the use of radiolabeled monoclonal antibodies in lymphoma cases and new agents for treatment of bone metastases.

## MIR Radiation Oncology Center to Host International Symposia

The months of April and May will be additionally busy for MIR's Radiation Oncology Center staff as they sponsor two major scientific meetings. Scheduled for April 21 through the 23rd at The Sheraton West Port Inn in St. Louis, the "3-D Radiation Treatment Planning and Conformal Therapy - an International Symposium" will provide up-to-date information on this revolutionary method of cancer treatment. Guest faculty are internationally recognized experts in the field of radiation oncology and will speak on a broad range of topics, including 3-D computerized

# SPOT NEWS

treatment planning for external beam and brachytherapy, CT simulation, conformal therapy delivery equipment and techniques, quality assurance, on-line imaging, computer networking, and 3-D dose calculation algorithms. In July of 1991, the Radiation Oncology Center opened the St. Louis area's first three-dimensional treatment planning center. Results of MIR's clinical trials on 3-D conformal therapy have been positive, and MIR faculty will share that information with symposium attendees.

The "Third International Brachytherapy and Remote Afterloading Symposium and Workshop" will be held May 19 through the 21st at the Hyatt Conference Center.

Lectures and workshops will offer a comprehensive review of basic dosimetry, clinical application of novel radioactive sources, treatment planning, dose specification, and quality assurance. Guest faculty represent a cross-section of top international and national clinicians and scientists whose presentations will have a significant impact on the clinical application of brachytherapy.

Each symposium has been designated as a Category 1 Continuing Medical Education activity.

## PET Research Team Receives DOE Grant

Researchers at the Institute are conducting a two-year feasibility study to determine if spheroidal positron emission tomography (PET) will yield better results than conventional PET in imaging the brain. The study is funded by a U.S. Department of Energy (DOE) grant in excess of \$670,000. According to principal investigator, Michel M. Ter-Pogossian, Ph.D., professor of radiation sciences, spheroidal PET has potential advantages over conventional PET systems: simultaneous imaging of the whole brain, increased sensitivity, and volumetric reconstruction of the data.

But Ter-Pogossian, who was a key contributor to the development of PET in the early 1970s, points out that he and team members David Ficke, B.S., research associate in radiology, and John Ollinger, D.Sc., assistant professor of biomedical computing, are not building a new PET system yet. First, the researchers must evaluate if there are benefits to be gained by distributing scintillation radiation detectors on a spheroidal surface. Since increased radiation scatter is the trade-off for a higher level of sensitivity in PET imaging, the team theoretically will investigate methods to compensate for the scatter. Another important segment of the research is the development of a computer to implement algorithms for clinical studies. At the study's conclusion, information gained from the investigation also will provide design parameters for the new PET device.

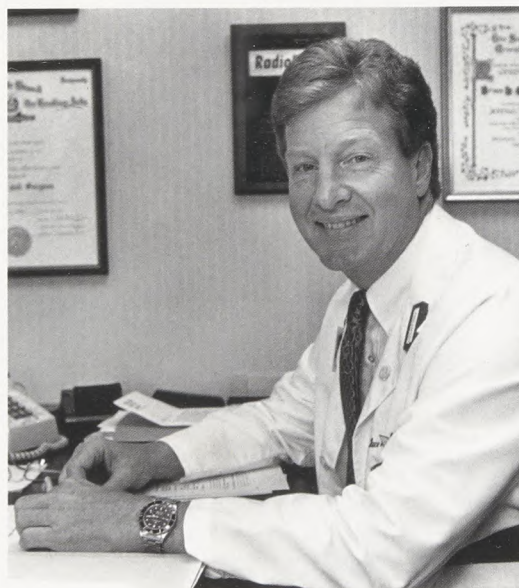

*Bruce L. McClennan, M.D.*

## McClennan Chairs ACR Committee

Bruce L. McClennan, M.D., professor of radiology and chief of abdominal imaging, was appointed chairman of the American College of Radiology (ACR) Committee on Drugs and Contrast Media, a special committee under the commission for general and pediatric radiology. McClennan, known for his expertise in the assessment of radioiodinated contrast agents and in the field of genitourinary radiological research, will be responsible for coordinating the committee's efforts in the critical issues involving radiological substances. He comes to this leadership position well prepared — as a former member of the drug and contrast media committee, McClennan was instrumental in the development of the ACR publication, "Report of Current Criteria for Use in

Water Soluble Contrast Agents for Intravenous Injections," as well as in the production of a manual on iodinated media.

McClennan is a Fellow of the ACR and a member of the Board of Chancellors as chairman of the Intersociety Commission.

The ACR was founded in 1924 and is the principal radiological organization, serving more than 28,000 members in diagnostic and therapeutic radiology and related disciplines.



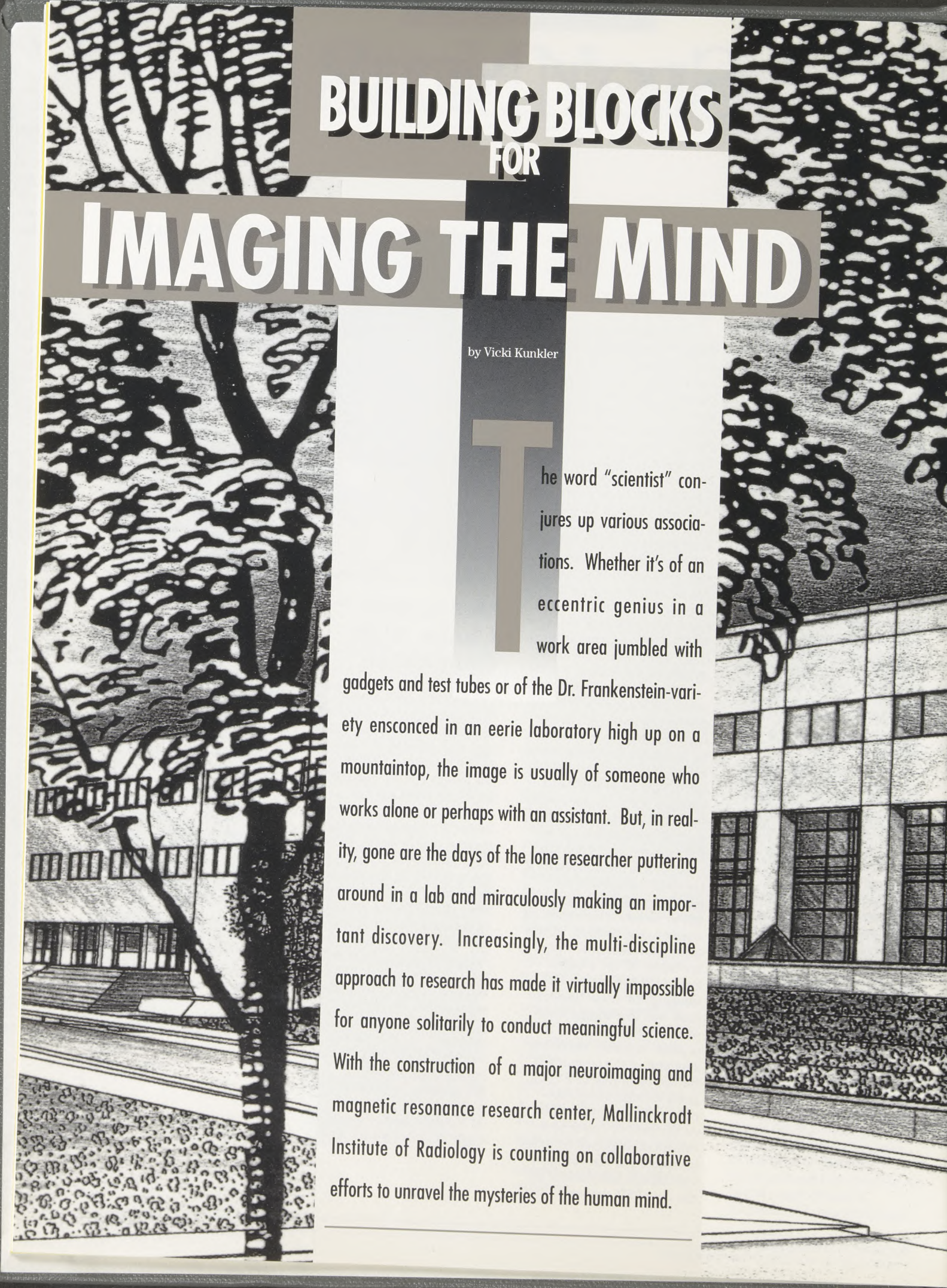

# BUILDING BLOCKS FOR

# IMAGING THE MIND

by Vicki Kunkler

**T**he word "scientist" conjures up various associations. Whether it's of an eccentric genius in a work area jumbled with gadgets and test tubes or of the Dr. Frankenstein-variety ensconced in an eerie laboratory high up on a mountaintop, the image is usually of someone who works alone or perhaps with an assistant. But, in reality, gone are the days of the lone researcher puttering around in a lab and miraculously making an important discovery. Increasingly, the multi-discipline approach to research has made it virtually impossible for anyone solitarily to conduct meaningful science. With the construction of a major neuroimaging and magnetic resonance research center, Mallinckrodt Institute of Radiology is counting on collaborative efforts to unravel the mysteries of the human mind.

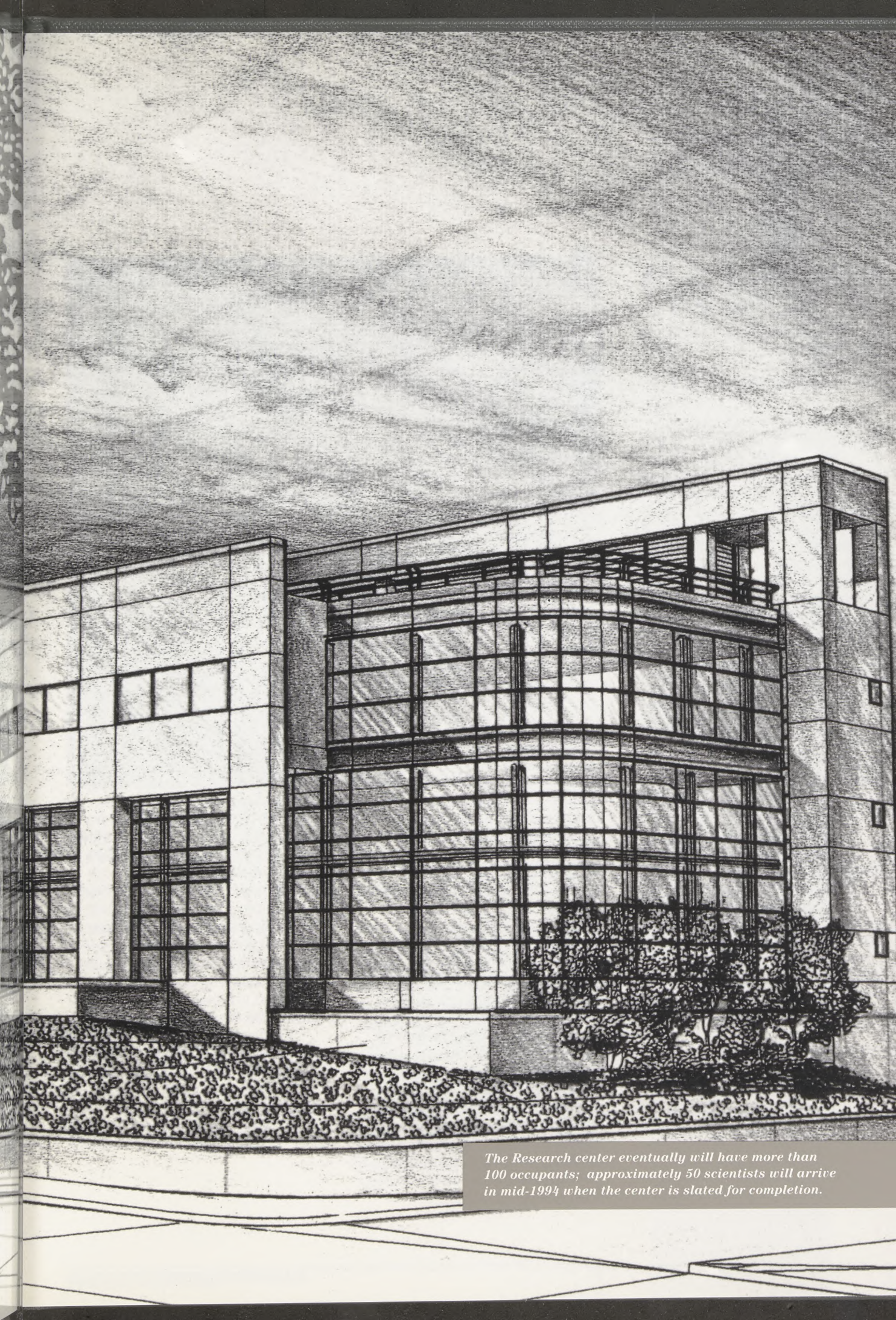

*The Research center eventually will have more than 100 occupants; approximately 50 scientists will arrive in mid-1994 when the center is slated for completion.*

## BUILDING BLOCKS FOR IMAGING THE MIND

Among the medical and public communities, the transfer of the Institute's technological component in July of 1992 to Barnes Hospital may have raised some questions and concerns about the future of MIR, but to William A. Peck, M.D., executive vice chancellor for medical affairs and dean of the medical school, and Ronald G. Evens, M.D., director of the Institute, the direction was clear-cut. In addition to aggressively pursuing an expan-

---

*"What we propose to do is even more important than mapping the brain, we're trying to map the mind."*

---

sion of clinical programs in collaboration with Barnes, Jewish, and Children's hospitals, it was time to implement an idea that had been mulled over for the past two years — to dramatically increase research activities at Mallinckrodt Institute. After consolidating advice from MIR faculty and other successful scientists in the Washington University School of Medicine departments as well as from universities nationwide, the project evolved into a four-pronged plan: build an infrastructure of computers and resources; establish a core of medical center scientists from key areas of imaging research; solicit the collaboration of major companies; and recruit scientists who have talents and skills to work on body imaging and new approaches to magnetic resonance imaging (MRI).

According to Evens, the catalyst for the project was Michael W. Vannier, M.D., director of the Division of Radiology Research and a pioneer in three-dimensional imaging. Vannier concurred with the plan for renewed emphasis on research but proposed that any increase should be based on the already proven strengths of the Institute — a tradition of excellence in imaging techniques, particularly positron emission tomography (PET); a major neurosciences team; and a large clinical base of patients as study resources.

With neuroimaging research as the logical first step in the expansion program, Mallinckrodt Institute held a deck stacked in its favor. Under the direction of Marcus E. Raichle, M.D., professor of radiology and neurology and head of neurological PET research, tremendous progress has been made in studying the brain. As one of the first researchers to use cyclotron-produced short-lived radionuclides with PET, Raichle's methods for measuring regional cerebral blood flow and metabolism provided a solid foundation for other researchers. His work in the past 10 years has focused on normal brain functions as well as major neurologic and psychiatric disorders through functional mapping of the brain, especially the areas involved in sensory and language information processing.

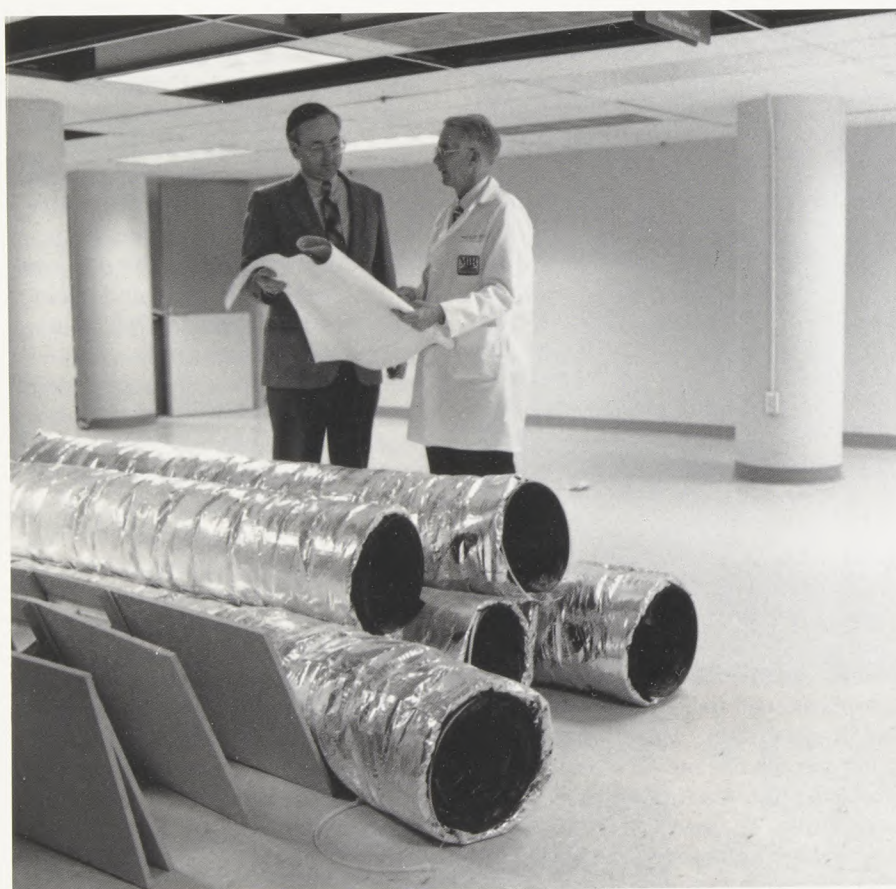

Another key researcher is Michael J. Welch, Ph.D., professor of radiation chemistry and director of the Division of Radiation Sciences. His work concentrates on the labeling of chemical compounds with short-lived radionuclides. The compounds that have been developed are used internationally for medical research and diagnosis.

Fueled by Peck's strong support, the project began to move forward. "Bill Peck believed that what we were really proposing to do was even more important than mapping the brain, we were going to try to map the mind," says Evens. "And he's right."

*Space allocation in the East Building for MIR and PET research support facilities was among the first of many steps toward realizing Michael Vannier's (left) and Ronald Evens' vision for "a place to study the mind."*

"To some extent, the brain has been mapped," Evens continues. "If you go to any textbook on anatomy, you'll see an outline of the brain and what portion of the brain controls which part of the body. But we know very little about the mind. With PET and MRI we have imaging techniques that, with careful planning and careful science, show great promise in revealing how the mind really works. And that's what we plan to study in this new research center."

"**A**ctually, we were ahead of ourselves," adds Vannier. "MRI research at the Institute was already on the move, and now we can advance into the field of functional imaging, beginning with the brain."

Raichle agrees. As invited speaker at the Institute's Twenty-first Annual Wendell G. Scott Memorial Lecture on October 5, 1992, Raichle concluded that although PET provides valuable information, he foresees that studies of the brain will increasingly involve MRI as a viable solution to problems associated with PET and the use of ionizing radiation. His talk, "Decade of the Brain 1990-2000: Importance of Brain Imaging Techniques in Understanding the Relationship Between the Human Brain and Behavior" provided a preview of the future of neuroimaging.

Vannier's involvement with the project went beyond his initial proposal. Next he had to convince the neurosciences team to buy into the idea. By attending the group's weekly lab meetings, Vannier learned about their research goals. Then, he outlined the benefits of a collaboration, suggesting to the team that "in order to be successful with further neuroimaging studies, the Institute must prepare for the future and join resources, using MRI and PET together to study and evaluate neurologic disease."

Luckily, the idea for the research center coincided with Raichle's desire to increase neuro PET. The research group had outgrown its space on the sixth floor of the Institute, and Raichle had approached Peck and the McDonnell Foundation about expanding the facility.

However, the only space available was in McMillan Clinic, not the ideal location for nurturing collaboration with radiation sciences and other involved groups. Meanwhile, Vannier and Evens had decided that the only plausible building site for the research center would be an annex to MIR's East Building, and they were interested in housing neuro PET in an accessible and complimentary facility.

Evens remembers his rushed telephone call to Raichle, proposing the new site. "Marc was somewhere in Seattle on vacation, probably up on a mountain or something," he says, referring to Raichle's enthusiasm for skiing and mountain climbing. "I called him and discussed the possibility of combining all of this research into one facility, and he quickly agreed."

The stage was set and progress since then has been steady. Funding of approximately \$18 million has been generated and pledged

for the center, with groundbreaking set for May of 1993. The Research Center (a temporary name until a more appropriate one can be chosen) will be an extension of MIR's East Building at 4525 Scott Avenue. The 45,000 square foot, multilevel structure will be freestanding, abutting the east end of the existing building and replacing the surface parking lots that extend to Taylor Avenue. There will be office and laboratory space for key collaborating scientists — psychologists, neurologists, engineers, chemists, graduate and

---

*Funding of \$18 million has been generated and pledged for the center with groundbreaking set for May of 1993.*

---

postgraduate program members, and physicists. Plus space for PET imaging, MR imaging, a neuropsychology laboratory, software support for computer imaging and analysis, animal care, chemistry (*in vivo* MR spectroscopy), electrical engineering (image reconstruction methods), and industrial liaisons (with PET/MR system manufacturers as well as pharmaceutical companies). The building also will include experimental, high field strength MR scanners for both human and animal subjects, advanced PET scanning systems, and the appropriate support systems.

**"A**nd Mike Vannier has made the entire project work," explains Evens. "He's done everything, from working with the architectural firm of Stone Marraccini and Patterson on space requirements to soliciting support and funding to actively recruiting scientists."

Foremost to the success of the project is the recruitment of additional top researchers. What do world-class scientists look for in a research environment? Vannier decided the best way to find out was simply to call and ask. After placing a multitude of telephone calls, he learned that a collaborative environment with an abundance of work space is a top priority along with dedicated state-of-the-art equipment and a stable, reliable relationship with suppliers and manufacturers.

With top-of-the-line computed tomography, PET, and MRI scanners along with various ultrasound machines, linear accelerators, and digital vascular imaging systems, the Institute has a corner on the equipment enticements. Plus MIR has long-term collaborations with companies like Siemens Medical Systems, Eastman Kodak, Mallinckrodt Medical, Varian Associates, Winthrop Pharmaceuticals, and E. I. DuPont de Nemours.

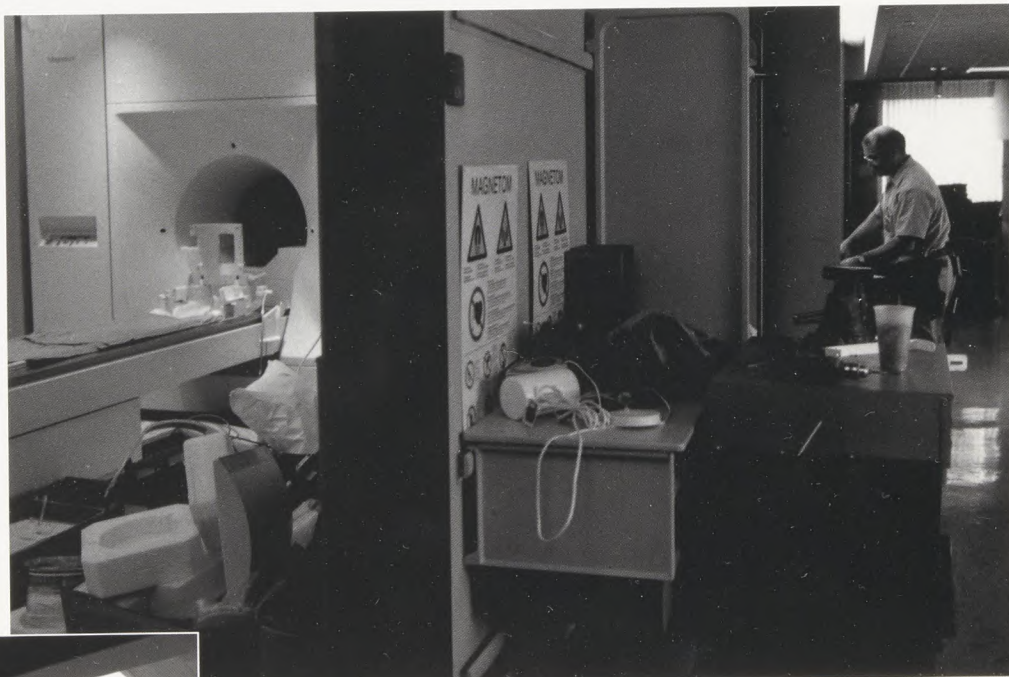

**"I** see this project as being so large and requiring so much expertise that there's absolutely no way any department alone could support it. Already collaborators include the departments of Internal Medicine, Molecular Biology and Pharmacology, Neurology and

Neurological Surgery, Psychiatry, Anatomy and Neurobiology, and Chemistry. And this list will increase as research programs are established," summarizes Evens. "I'm looking forward to putting a spade into the ground and to seeing the new building completed." □

*Work in the existing East Building has already begun — labs and a special, lead-sheathed room for the new accelerator used in isotope reproduction (left) and the installation of a stronger magnet for MRI research (above).*

# FILLING IN THE GAPS WITH SPIRAL CT

MIR RESEARCHERS EVALUATE A NEW  
VERSION OF COMPUTED TOMOGRAPHY.

In the early 1970s, scientists at Mallinckrodt Institute played a key role in the development of computed tomography (CT), a technology that revolutionized the field of radiology. For the first time in medical history, an imaging device could produce cross-sectional images of the body, allowing physicians to differentiate between diseased and healthy tissue. This noninvasive diagnostic procedure could detect early-stage tumors, reveal blood clots and enlarged organs, and locate abnormal cavities within the body. While health-care professionals did not deny the importance of CT, many believed that the \$500,000 price tag for a scanner would drive up medical costs without significantly improving diagnostic accuracy.

Two decades and scores of studies later proved that in some cases the noninvasive CT procedure could eliminate exploratory surgery, shorten hospital stays, and reduce actual surgery time by providing specific and unique diagnostic information. CT has virtually replaced some of the more expensive radiological procedures, such as angiography, lymphangiography, and myelography. And, all of these benefits are possible with little discomfort to the patient and without exposure to high levels of radiation.

In 1990, Siemens Medical Systems, Inc., a medical equipment company based in Erlanger, Germany, introduced to U.S. medical centers a newer version of computed tomography called spiral CT. The Institute received one of the first units produced and now has three units in place. Although studies are underway nationwide, MIR is the only institution in the St. Louis area to investigate the benefits of this upgraded technology that promises to reduce scanning time and lower risks to patients. CT has demonstrated its diagnostic value, but spiral CT must now prove itself as the successor.

B Y V I C K I K U N K L E R



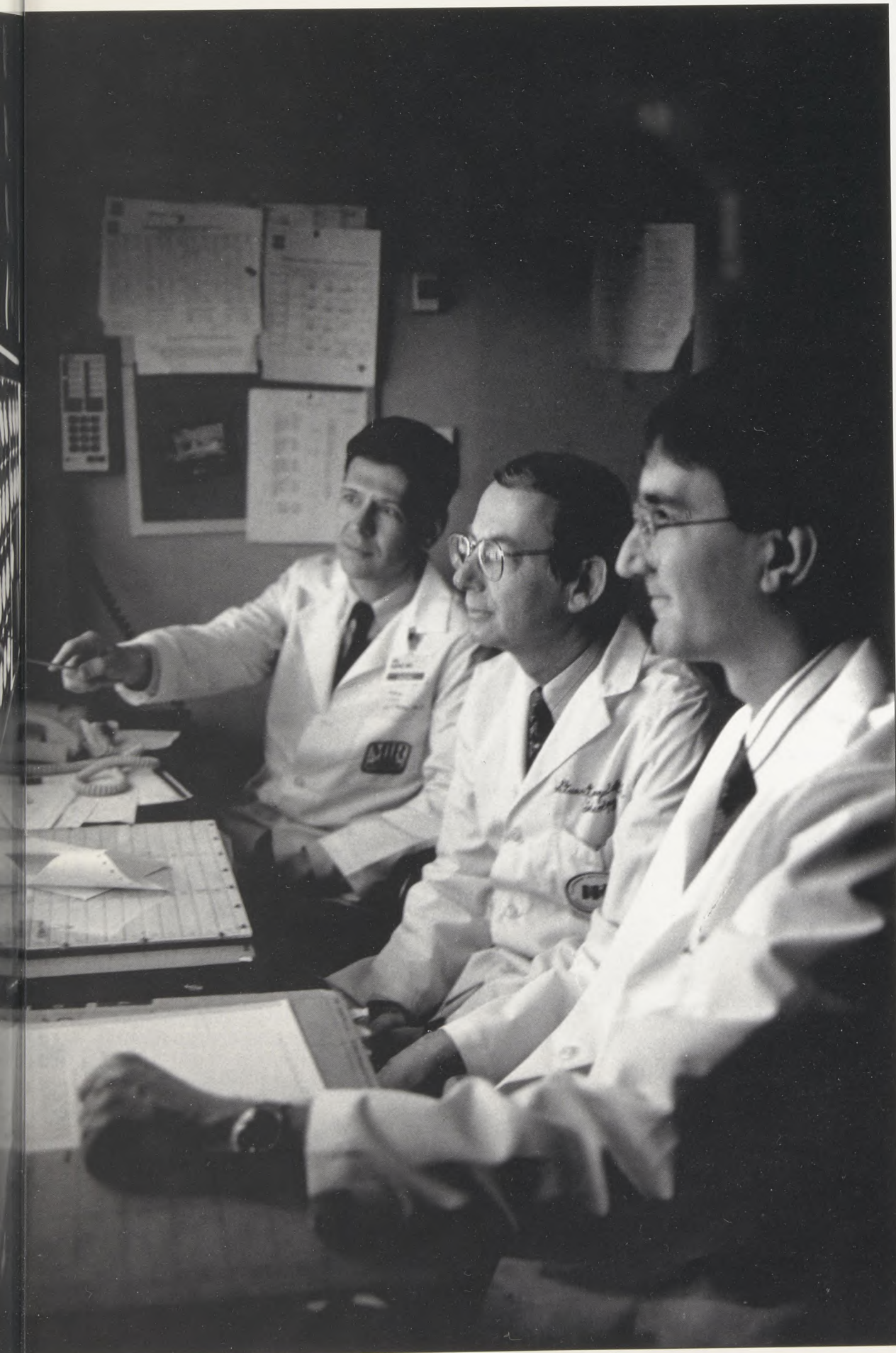

*Doctors James A. Brink (foreground), Stuart S. Sagel (middle), and Jay P. Heiken are evaluating diagnostic information provided by spiral CT.*



FILLING IN THE  
**GAPS**  
WITH SPIRAL CT

**W**hile CT often has been hailed as the greatest medical discovery since the X ray, the technology also has disadvantages. Rotation of the CT gantry is operated by cables, allowing movement of 180 degrees in one direction before the gantry must be reversed and revolved in the opposite direction. CT images are taken in one-slice increments, requiring additional time for the patient to breathe between scans and for the table to be moved for each image. Total scanning time can take from two to three min-

*Spiral CT allows the table to move through the gantry at a steady pace.*

utes, while the patient inhales, maintains a five-second breath-hold, and exhales for each of the 24 slices taken during an average scanning. And respiratory motion can produce image artifacts that affect the final diagnosis.

Ideally, the slices should all fit together like a puzzle, but if a patient takes a deep breath on one scan and a lesser inspiration on the next scan, the resulting slices may contain gaps of information. Known as respiratory misregistration, these inconsistent levels of breathing, or any patient motion, may cause omission of some areas or repeated scanning of others. Respiratory misregistration also

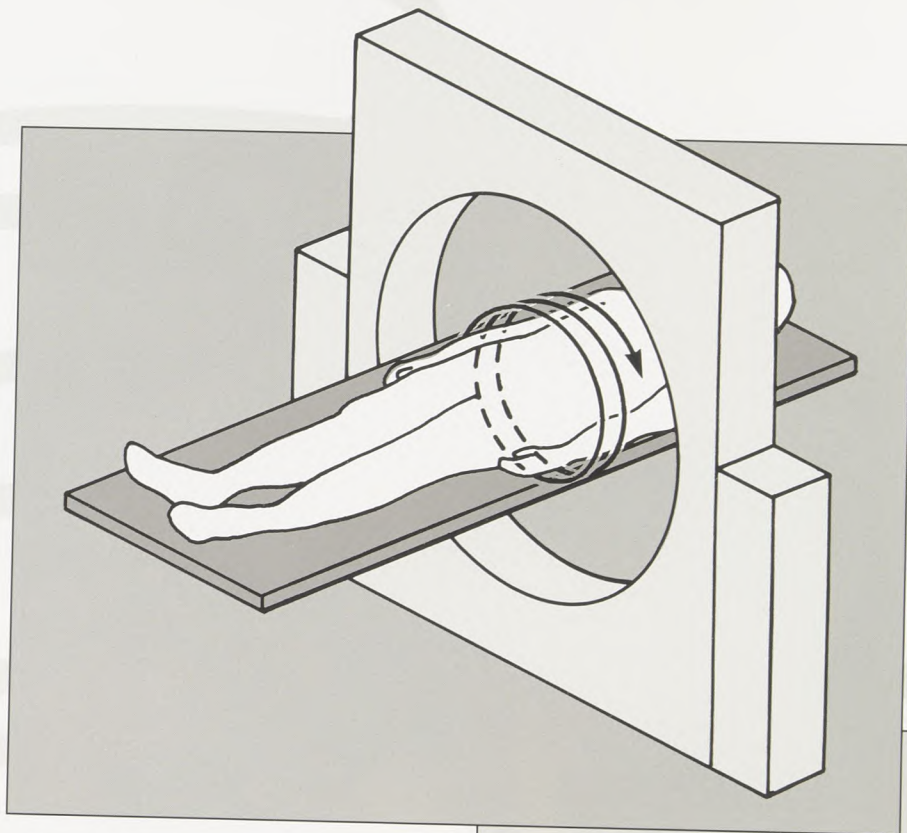

affects the consistency of the image density, and bone tissue can be averaged in with the density of a mass, resulting in a false report.

So, why all the hoopla about spiral CT? At first glance, the paraphernalia of the unit resembles that of the conventional CT equipment: the gantry with the doughnut hole in the middle, the table that moves in and out of the gantry's opening, the detectors, the X ray source, and the computers. A closer inspection reveals the absence of the tangle of cables connected to the conventional scanner. And it is this detail that gives spiral CT the edge in the computed tomography race.

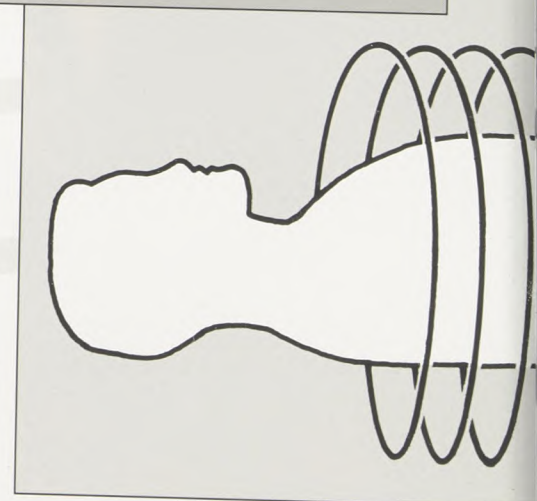

**S**piral CT operates on slipping technology, allowing the table on which the patient is positioned to move through the gantry at a steady pace. Table speeds vary with each manufacturer, usually from five to 10 millimeters per second. The detectors and the X-ray source rotate in a continuous 360 degree pathway. While the patient's entire body moves continuously through the gantry, the X-ray beam traces a spiral motion around the patient.

*In spiral CT, the X-ray tube and detector rotate continuously in a spiral motion around the patient. Imaging is on a virtual cylindrical surface with an equal distance between slices.*



The different projections of the pathway involve sophisticated reconstruction algorithms programmed by the unit's computers. Volume CT acquisition is achieved with the patient taking a single breath-hold, eliminating respiratory misregistration and image artifacts. Total scanning time ranges from a few seconds up to one-half minute, and the images are comparable to images from conventional CT.

## THE HISTORY OF CT AT MALLINCKRODT INSTITUTE

In 1968, Sir Godfrey Newbold Hounsfield, a research engineer with a British electronic company called EMI, Ltd., developed a groundbreaking technology — medical diagnostic equipment that could produce three-dimensional representations of any portion of the body. Computed tomography incorporated X-ray technology with computers. While the concept of CT was good, what Hounsfield needed was guidance from the medical field to adapt the idea for clinical use.

Mallinckrodt Institute's reputation as a top quality research facility was internationally known. So, Hounsfield made the trip to St. Louis where he and MIR scientists and clinicians began a productive collaboration. In 1972, one of the first prototype CT head scanners was introduced at the Institute. MIR researchers and Hounsfield later modified the initial technology and created a scanner that could image the entire body. In 1975, MIR was one of three institutes worldwide to receive the first whole-body CT units — the other two scanners went to the Mayo Clinic in Minnesota and to Northwick Park Hospital in England — and was the first in the United States to have two units. Hounsfield's efforts earned the 1979 Nobel Prize in medicine.

In 1985, MIR investigators produced a best-selling textbook on computed tomography. Hailed as "a landmark publication of critical interest to every radiologist — a comprehensive, up-to-date, superbly illustrated guide to computed tomography of extracranial organs," *Computed Body Tomography* was a compilation of more than 25 MIR



*Sir Godfrey Newbold Hounsfield*

staff members' clinical experiences with this state-of-the-art equipment. The volume was edited by Joseph K. T. Lee, M.D., currently chairman of the Department of Radiology at the University of North Carolina at Chapel Hill; Robert J. Stanley, M.D., who now is chairman of the Department of Radiology at the University of Alabama Hospital in Birmingham; and Stuart S. Sagel, M.D., MIR's cochief of computed tomography. Stanley and Sagel, along with Michel M. Ter-Pogossian, Ph.D., and John V. Forrest, M.D., collaborated with technical representatives from EMI during the CT clinical testing and evaluation program at the Institute. The textbook, now in its second edition, continues to be used by physicians worldwide.

In an interview marking a decade of CT technology and application at the Institute, Sagel said, "It [CT] made us [radiologists] all better interpreters of plain film radiography because it taught us anatomy in better detail than we ever knew before. When I first began to work with CT...I found that CT had taken me back to the study of medicine as a whole. That was exciting."

Widely respected for their expertise in the clinical applications of CT, MIR researchers were pioneers in the integration of three-dimensional technology with CT and magnetic resonance imaging. □

FILLING IN THE  
**GAPS**  
WITH SPIRAL CT

**T**his new technology may have an advantage in the use of contrast media, a clear solution containing iodine that is injected into the patient's blood vessel. The solution permeates the organ being examined and enables the radiologist to better study blood flow and detect tumors, obstructions, and other diseases. There are two types of contrast media — ionic and non-ionic. Ionic agents create electrically charged particles in the blood stream, causing undesirable effects in the patient, such as respiratory problems, nausea, a decrease in blood pressure, some pain, or the sensation of higher body temperatures. Patients with allergies or cardiac disease or those patients who have had a previous reaction to contrast solutions are at a higher risk of an adverse reaction. While the nonionic agents are safer and better tolerated by patients, the cost can be 10 to 12 times higher than ionic contrast. Because of the rapidity of spiral CT, in many cases the amount of contrast media can be reduced, resulting in less irritation to the patient, less motion artifact, and cost savings — especially when the more expensive nonionic material is used.

James A. Brink, M.D., assistant professor of radiology, is principal investigator of a large-scale study at the Institute to determine the optimum dosage and delivery method of contrast media used with spiral CT. Funded by a \$326,000 grant from Sanofi Winthrop, the pharmaceutical unit of Sterling Winthrop, Inc., the study began in January of this year and will include 800 patients.

Brink and coinvestigators Jay P. Heiken, M.D., cochief of computed tomography; Stuart S. Sagel, M.D., cochief of computed tomography; Christopher J. Moran, M.D., neuroradiology section; and Howard P. Forman, M.D., radiology resident, are focusing their research on three areas of the body — neck, chest, and abdomen.

---

*Because of the rapidity of spiral CT, the amount of contrast media may be reduced...*

---

**“I**n each of these three mini-studies, we are integrating all the variables we can choose, such as type of contrast, volume, and rate of administration. Three injection rates and three volumes of the non-ionic contrast Ioversol are being used,” says Brink. “So far, we have scanned thirty patients, but it's too early to predict results.”

A preliminary study at the Institute involved 80 patients with suspected thoracic pathology. Images from the Siemens Somatom Plus spiral CT scanner demonstrated good thoracic vascular opacification using reduced contrast dosage. Results of the study were presented in May of 1992 at the annual meeting of the American Roentgen Ray Society. Investigators Paul Molina, M.D.; Brink; Heiken; Sagel; and Joseph DiCroce, R.T., concluded that optimum use of reduced volumes of contrast material requires close attention to contrast media infusion technique, rates, and scan delay times.

**A**s perfect as spiral CT might sound, it does have some drawbacks. According to Heiken, “Ideally, we would like to use spiral CT for just about every examination done in the computed tomography section, but because this imaging method requires a tremendous amount of data, storage of that data presents a big problem.”

Other disadvantages include an interruption of from eight to 12 minutes while the computer's linear interpolation algorithm reconstructs slices from the data. There is no instant readout as with conventional CT. Also, the high power demands on the X-ray tube during volume scanning can cause the tube to heat up, requiring a cooling-down period before the next scan can be taken. For now, application is optimal in areas with low X-ray attenuation, such as the lung. However, manufacturers are working to correct the problem. While the rapidity of spiral CT makes it advantageous for pediatric and trauma patients and those with neurological impairments, the one breath-hold does cause problems for patients with pulmonary insufficiency and some elderly patients who cannot hold one long breath.

What's in the future for spiral CT? Researchers believe that spiral CT's direct volume acquisition has great potential for three-dimensional display and can optimize surgical or radiation therapy benefits to the patient. Many radiologists predict that within three to five years virtually all computed tomography will involve the technology of spiral CT. □



*Katheryn's now enjoying good health and is back teaching at one of the Head Start programs sponsored by the City of St. Louis.*

According to Katheryn, "At first the doctor thought I had a virus that had gone into pneumonia. Because I had such a terrible pressure in my chest, the doctor ordered X rays that revealed a mass in my bronchial area."

When Katheryn underwent a complete physical examination, a lump was discovered on her left side near her

underarm. After reviewing Katheryn's medical history and learning that her mother had died as a result of lymphatic cancer of the chest, the physician decided diagnostic tests were necessary to accurately determine the cause of Katheryn's symptoms. She was admitted to the hospital that evening and scheduled for a CT as well as a mammogram and a needle biopsy.

Katheryn admits to being frightened. "I have a thirteen-year-old son, Brandon, and I want to see him grow up," she says. "I just put my faith in God and in the doctors and decided that I would be all right."

She received a clean bill of health from the mammogram and the biopsy. Next came the CT. Katheryn says that the technologist gave her a preview of what to expect — that she might feel some pressure on her bladder or experience a heat sensation from the contrast media.

"Being able to hear a pleasant voice through the headphones while I was in the machine eased my mind," says Katheryn. "I didn't have any trouble lying still but because of my breathing problem, I had to take two breath-holds instead of just the one I had been told about. The whole procedure couldn't have taken more than a minute."

The CT scan ruled out cancer, and, after a series of breathing treatments, Katheryn was sent home with an inhaler, some antibiotics, a prescription for iron tablets, and "peace of mind." □

## A PATIENT'S PERSPECTIVE

**K**atheryn Ferguson thought she had all the symptoms of the common cold — itchy throat, sneezing, fever, aches, chills, congestion. She tried home remedies and over-the-counter medications with no relief. Katheryn's illness accelerated after a week or so, adding to the already burdensome list of symptoms a pressure in her chest, fatigue, night sweats, heartburn, loss of appetite, and the inability to lie on her right side without experiencing a choking sensation. One evening the pressure in her chest became so unbearable, Katheryn rushed to the Barnes Hospital emergency room.

ELECTRONIC RADIOLOGY:

# THE DIGITAL



*Above: At RSNA's meeting in Chicago, some of the nation's top medical-imaging equipment companies participated in an on-line demonstration that stressed the importance of digital information management.*

*Right: R. Gilbert Jost (foreground), G. James Blaine (middle), and Stephen M. Moore designed the software system.*

# DREAM

by Cliff Froehlich



**A** decade ago, when the video cassette recorder was first insinuating itself into our homes and lifestyles, two competing and incompatible tape formats (Beta and VHS) were available to consumers. Both had their advantages and their ardent defenders, but because a tape made on one type of machine could not be played on the other, the marketplace dictated that only one — VHS — would eventually survive.

Consumers wanted to share with others the television shows, movies, and home videos they had recorded or collected. But to do that, a uniform standard had to apply, a single format had to emerge before tapes could be traded freely.

Physicians have an analogous desire to exchange visual information but, instead of swapping videotapes, they share medical images — everything from chest X rays to positron emission tomography scans — as a means of consulting with one another about diagnosis and treatment. And as radiology moves further into the digital age, such data increasingly will be stored, moved, and retrieved electronically.

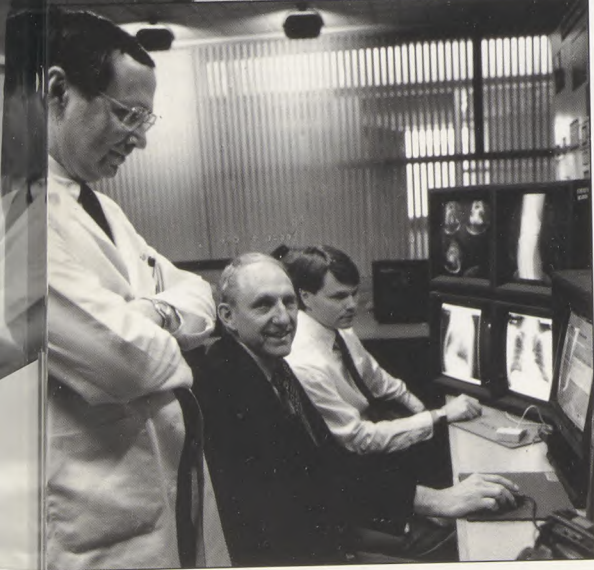

To ensure that everyone has equal access to this information, a standard must be developed so that a computed tomography scan obtained on one manufacturer's device can be read, after its electronic "shipping" to another location, on a machine made by a second supplier. But at present those images, like Beta and VHS tapes, often

cannot be shared in digital form because of variations in equipment from different manufacturers.

**"T**here's a real problem in the medical industry these days in that every vendor has its own way of storing medical images," says R. Gilbert Jost, M.D., chief of the Division of Diagnostic Radiology at Mallinckrodt Institute of Radiology (MIR). "If a hospital buys a piece of equipment from General Electric and another from Siemens, the images are in totally different formats and do not communicate. That causes some problems, particularly if you want to electronically send the images around the department or to other sites."

According to Jost, having some kind of standard that is agreeable to the industry would result in universal storage of images. It's not a new concept. Ten years ago, a group was formed to define such a standard, but progress has been slow.

"For years, all of the manufacturers have been professing support and interest in this standard," Jost continues. "But when push comes to shove, they just can't get the competitiveness out of their systems long enough to really figure out how to send images to one another."

"Standards take a long time to develop, and they require a significant effort to get a consensus of a large body of people," explains G. James Blaine, D.Sc., associate professor of computer sciences in radiology and head of MIR's Electronic Radiology Laboratory. "Until they get that consensus, the standard won't be adopted."

Last year, however, a major step was taken in the definition of that standard — with Mallinckrodt Institute playing a significant role as a literal consensus builder.

# THE DIGITAL DREAM

The American College of Radiology (ACR) and the National Electrical Manufacturers Association (NEMA) have been working together to define the standard for the formatting and exchange of electronic images. The first version of the ACR-NEMA Standard was developed in 1984, and a second version followed in 1989. A third version, now called the Digital Imaging and Communication (DICOM) Standard, is scheduled for completion this year. To illustrate the new standard and its viability, ACR and NEMA agreed to a demonstration at the 78th Scientific Assembly and Annual Meeting of the Radiological Society of North America (RSNA '92) in November of last year.

Steve Drew, RSNA director of informatics, explains the impetus behind the demonstration: "The members of the RSNA's Electronic Communication Committee, known as ECC, feel that the concept of the standard is vital to the efficiency of performing their jobs in the clinical setting. For whatever reason, work on this had been stagnating. The ECC wanted to encourage ACR-NEMA to bring it to life and get it moving, so the committee approached ACR-NEMA and told them we were interested in doing some sort of demonstration."

*"...in the medical industry, every vendor has its own way of storing medical images."*

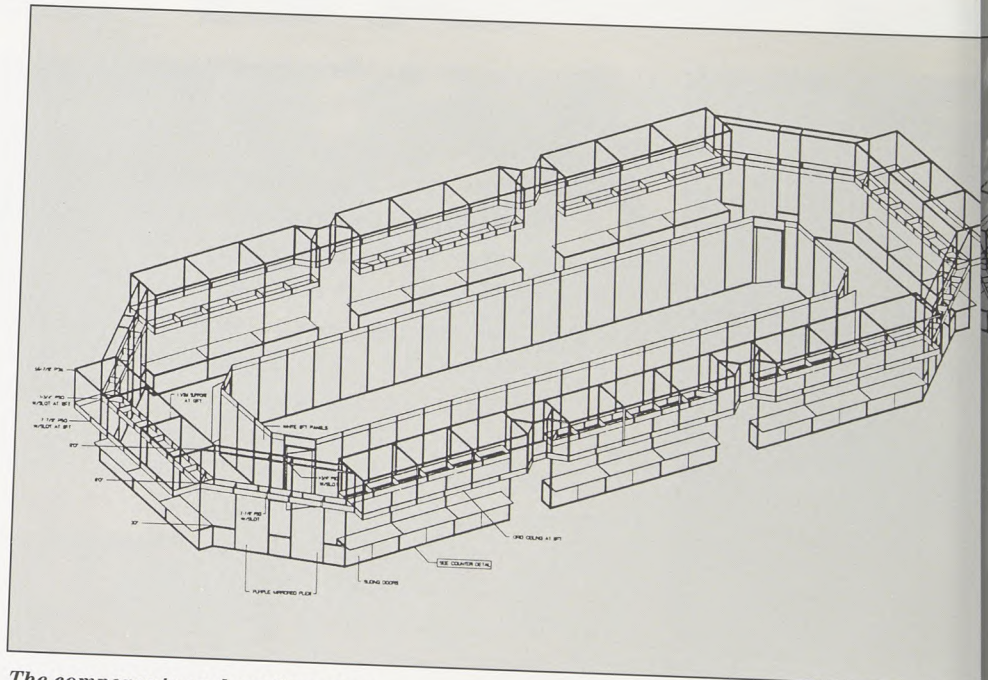

*The components and configuration of the exhibit were designated by the RSNA Electronic Communications Committee.*

Groundwork began early in 1992 to set the stage for a demonstration at RSNA that would call for manufacturers to transfer images via the newly evolving DICOM Standard. In setting up the demonstration, a simple realization (and according to Jost, an important insight) was made: A software layer, a package of software that could run on everyone's equipment and support the initial "handshake" between machines, was required.

Rather than allowing the industry to develop the necessary software, which could potentially have placed one company at a competitive advantage, RSNA decided to offer universities nationwide the opportunity to "bid" on the project. Washington University's Mallinckrodt Institute, a longtime innovator and proponent of electronic radiology, eventually emerged as the competition's victor.

But winning the contract was perhaps the easiest step in the process. "The time scale was very, very short," admits Jost. "They issued the 'Request For Proposal' in April and called for responses within a week or two. RSNA awarded the contract to MIR on May fifteenth and called for software to be developed by July fifteenth. That provided only two months for development, which placed extraordinary time constraints on us."

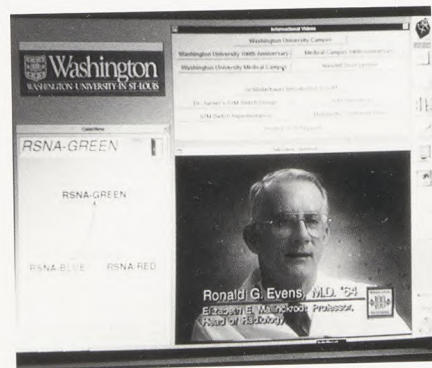
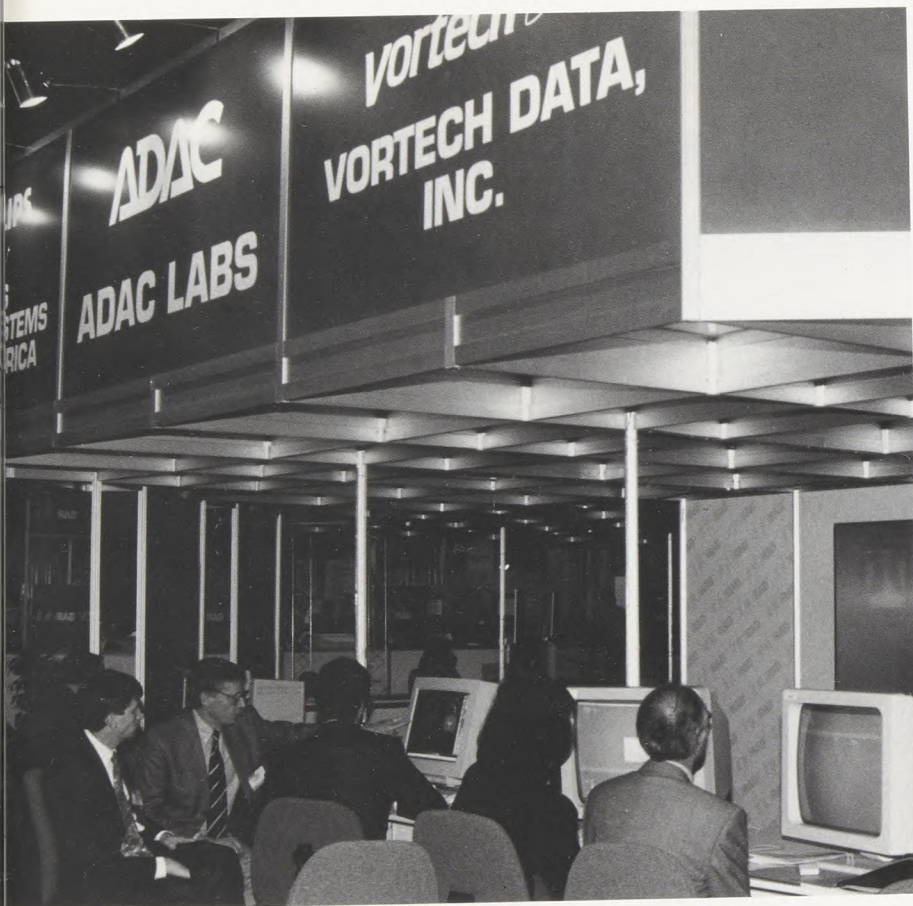

*The exhibit included a central test node (CTN) that received and handled images provided by each of the participating companies. The CTN also supported remote high-speed telecommunications links to off-site demonstrations.*



MIR's Electronic Radiology Laboratory (ERL) fortunately proved up to the challenge, digging into the project with a high level of professionalism. By all accounts, the software was virtually flawless, even from the time of its first testing.



# THE DIGITAL DREAM

“The engineering team at the ERL did an extraordinary job,” echoes Blaine. “That’s due in large part to the personal efforts and skills of Stephen Moore, our software architect. Some of the more pleasing comments were from some participants who thought that the time scale most likely was too ambitious to be accomplished. Normally, you would expect to spend six months or more in generating a quality piece of software of that complexity.”

As Jost understates, “It was a full-court press here for a couple of months.”

The software’s pre-RSNA trial in September provided a good measure of its quality. It was anticipated that four or five days would be necessary to shake the bugs from the system, but the software performed so well that within the first day, the 20 participating manufacturers were all working with it successfully.

---

*The software was virtually flawless, from the first testing.*

---



*All participants in the ACR-NEMA DICOM Standard demonstration were connected to an international computer network called Internet that provided an open forum for the prompt exchange of information.*



Jost agrees that a very limited set of the standard was demonstrated but, nevertheless, thinks it was a most important milestone to have 20 major companies all demonstrating the concept and

communicating. At RSNA in 1993, the challenges will be greater in terms of a broader application of the standard and the involvement of many more companies. In future years, connectivity may be available to all commercial vendors at the RSNA meeting.

And even given the circumscribed nature of the initial demonstration, Jost is high-

ly encouraged. "The significance of this is the telescoping into a few years of a process that otherwise might have taken ten years. It has encouraged industry to come together and demonstrate that they can in fact exchange images with one another. It's a terribly important step forward."

Further steps, of course, will lead to actual clinical applications. Once all manufacturers of radiological equipment accept and incorporate the DICOM Standard, thereby making images available in the same format, electronic radiology will take a major stride forward to becoming not only possible but practical.

"What this effort finally did was to bring out of the closet a standard that could make possible the universal transfer of digital image data," says Drew. "It opens up a lot of opportunities and new developments," agrees Jost. "Imagine putting all the radiology images in the St. Louis area on a network and allowing doctors to retrieve images from anywhere."

The most encouraging aspect of these recent developments, from Jost's viewpoint, is the unity displayed by all participants, whatever their disparate interests. "What's exciting about this is that everybody seems to be cooperating and moving ahead together," concludes Jost. "The manufacturers, the ACR, the RSNA, the universities — everybody's saying this is the way we ought to do it, and it's moving ahead at a remarkable pace." □

*Editor's Note: Cliff Froehlich, a former managing editor of Focal Spot, is executive editor of The Riverfront Times.*

The results of the RSNA demonstration, which Jost describes as one of the show's important centerpieces, proved just as pleasing. "We were very happy on the professional-membership side of things," says RSNA's Drew, "and from what we gathered from the commercial side, they thought it was a great success, also."

Blaine does caution that the exhibit at RSNA '92, though highly successful, was a limited demonstration of the DICOM Standard. For example, there was no transmission of images directly from vendor to vendor. A "central test node" allowed vendors to send images to private storage and then display them on the central test node. Or images could be retrieved from a public storage area on the central test node and displayed on each vendor's own display station.

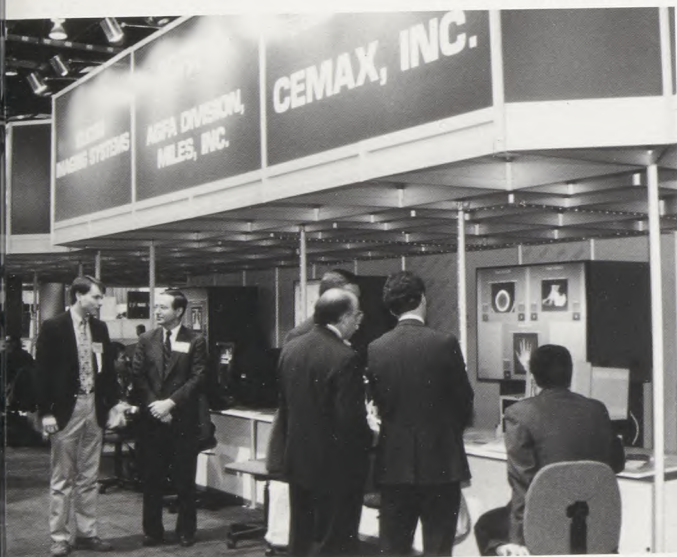

# FYI

## THE DIRECTOR'S OFFICE REPORT

### NEW STAFF

**Prem Sri T. Barton, M.D.**, assistant professor of radiology, Division of Diagnostic Radiology

**Julie A. Fiez, Ph.D.**, research associate, Division of Radiology Research

**Glenn Fletcher, Ph.D.**, instructor in radiology, Division of Radiology Research

**Douglas R. Spitz, Ph.D.**, assistant professor of radiology, Division of Radiation Oncology

**William Straube, M.S.**, instructor in radiology, Division of Radiation Oncology

**Ge Wang, Ph.D.**, instructor in radiology, Division of Radiology Research

**O. Clark West, M.D.**, instructor of radiology, Division of Diagnostic Radiology

**Xiao-Rong Zhu, Ph.D.**, research associate in radiology, Division of Radiation Oncology

### NEW FELLOWS

**Maurice L. King, M.D.**, instructor in radiology, is a fellow in radiation oncology. He completed two years of residency in radiation oncology at Mallinckrodt Institute of Radiology.

### PROMOTIONS

**Carolyn J. Anderson, Ph.D.**, was promoted to assistant professor of radiology, Division of Radiation Sciences.

**Thomas K. Pilgram, Ph.D.**, was promoted to instructor in radiology, Division of Radiology Research.

### OFF STAFF

**Peter P. Lai, M.D.**, assistant professor of radiology, Division of Radiation Oncology, has entered private practice in Visalia, California.

**Frederick A. Mann, M.D.**, assistant professor of radiology, Division of Diagnostic Radiology, has accepted a position in the department of radiology (trauma, emergency radiology, and musculoskeletal) at Harborview Hospital, University of Washington Medical Center, Seattle.

**Paul L. Molina, M.D.**, assistant professor of radiology, Division of Diagnostic Radiology, has accepted the position of director of the computed body tomography and cardiopulmonary radiology sections at the University of North Carolina, Chapel Hill.

## VISITING PROFESSORS & INVITED LECTURERS

**James A. Brink, M.D.**, assistant professor of radiology, presented "Spiral CT of the Biliary Tree: Comparison with Direct Cholangiography" (coauthored with doctors **Jay P. Heiken, Dennis M. Balfe, Jeffrey J. Brown, Joseph A. Borrello, and Michael W. Van-nier**) and "Spiral CT Angiography for Renal Arterial Stenosis: In Vitro Assessment of Technical Parameters" at the Scientific Session of the Society of Computed Body Tomography and Magnetic Resonance, Orlando, February 28. He also presented "Spiral Computed Body Tomography" and "Imaging of Renal Masses" at the Texas Society of Radiologic Technologist's Annual Meeting, Houston, March 12.

**Jeffrey J. Brown, M.D.**, assistant professor and chief of the magnetic resonance imaging section, spoke on "Biologically Relevant Properties of Gadolinium Chelates" at St. Louis University Medical Center, St. Louis, January 20. He presented "MRI of the Heart and Great Vessels," "MRI of the Liver," and "MRI of the Retroperitoneum: Pancreas, Kidneys, Adrenals" at the 8th Annual San Diego Postgraduate Magnetic Resonance Imaging Course, San Diego, March 9 - 10. Brown spoke on "Fast Scanning Techniques in the Abdomen" and "MRI of the Great Vessels" at the 36th Annual Diagnostic Radiology Postgraduate Course, San Francisco, March 25.

**Bahman Emami, M.D.**, professor of radiology and associate director of the Radiation Oncology Center, presented "Research of Target Volume in the Therapeutic Integration for Lung Cancer," "Research of Target Volume in the Therapeutic Integration for Prostate Cancer," and "Clinical Applications of 3D Conformal Radiotherapy" at the Residential Course on the Research of the Target Volume in Therapeutic Integrations, Rome, November 16 - 20. As invited speaker, he lectured on "Three-Dimensional Treatment Planning" at the Greater St. Louis Society of Radiologists, St. Louis, February 16. Emami spoke on "Management of Hilar and Mediastinal Lymphatics with Radiotherapy" at the 28th Annual San Francisco Cancer Symposium, March 6 and 7.

**Louis A. Gilula, M.D.**, professor of radiology and cochief of the musculoskeletal section, spoke on "Analytical Approach to Complex Carpal Injuries" at Brigham and Women's Hospital, Harvard University, Boston, February 4. Gilula presented "CT of the Wrist" at Semmelweis University of Medical Sciences, Budapest, March 3. He also presented "Analysis of Complex Wrist Trauma," "Ligament Instability of the Wrist," "MRI of the Wrist," and "CT of the Wrist: A Tailored Approach" at the 3rd Wiener Osteoradiologic Symposium, University of Vienna, March 5.

# FYI

**Harvey S. Glazer, M.D.**, associate professor of radiology, presented "Differential Diagnosis and Pitfalls in Mediastinal CT" at Tidewater Radiological Society, Norfolk, December 9. As visiting professor, he spoke on "Differential Diagnosis of Chest Pathology," "CT/Plain Patterns of Atelectasis," and "CT of Low Attenuation Neck Masses" at Eastern Virginia Medical School, Norfolk, December 9 - 10. Glazer presented "CT of the Postoperative Chest" and "CT of Mediastinum: Normal and Pitfalls" at the Society of Computed Body Tomography and Magnetic Resonance, Lake Buena Vista, Florida, March 1 - 5.

**Perry W. Grigsby, M.D.**, associate professor of radiology and clinical chief of the Radiation Oncology Center, presented "Gynecologic Brachytherapy," "Vaginal Cancer," "Cervical Cancer," "Management of Pituitary Tumors," and "Therapy for Thyroid Malignancies: Indicators and Results" at the 45th Midwinter Radiology/Oncology Conference, Los Angeles Radiological Society, January 15 - 17. He lectured on "Gynecologic Brachytherapy" to the Department of Radiation Oncology, University of Toronto, Ontario, January 28.

**Jay P. Heiken, M.D.**, associate professor of radiology and cochief of computed body tomography, presented a scientific paper on "Gas-containing Posterior Pararenal Space Fluid Collection: An Indication of Colonic Disease" and, as invited lecturer, presided

over a workshop, "CT Liver Contrast Enhancement Techniques," at the Twenty-second Annual Meeting of the Society of Gastrointestinal Radiologists, Scottsdale, January 17 - 22. He spoke on "Hepatic Masses: Detection and Characterization with MRI," "Diffuse Hepatic Parenchymal Disease," "Imaging of the Retroperitoneum," "Imaging of the Female Pelvis: Malignant Disease," and "MRI of the Kidney and Adrenal Gland" at Seminars in MRI, sponsored by the Loyola University Chicago Stritch School of Medicine, Vail, Colorado, January 23 - 30. He lectured on "Spiral CT: Theory, Techniques and Applications in the Chest and Abdomen," "Contrast Enhancement Techniques for CT of the Liver," "CT and MRI of the Retroperitoneum," and "Imaging Evaluation of Renal Masses" at Brain to Pelvis: 1993, sponsored by the University of Minnesota Medical School, Beaver Creek, Colorado, February 21 - 26. Heiken spoke on "Contrast Enhancement Techniques for CT of the Liver" and presided over a workshop, "Spiral CT: Theory, Technique and Abdominal Applications," at the Sixteenth Annual Course, Society of Computed Body Tomography and Magnetic Resonance, Orlando, March 1 - 5. He lectured on "Detection of Abdominal Metastases" at the 1993 Society of Air Force Physicians meeting, St. Louis, March 9. Heiken presided over the workshop, "Imaging of the Peritoneal Spaces," and lectured on "CT/MR Evaluation of Gyne-

cologic Neoplasms" and "CT/MR of Hepatic Masses" at the International London Course in Computed Tomography, Auchterarder, Perthshire, Scotland, March 14 - 18.

**Andrei Laszlo, Ph.D.**, assistant professor of cancer biology, as visiting professor presented "Mammalian Heat Shock Proteins" at the Cancer Research Laboratory, Department of Radiology, Stanford University, November 12. He presented the eyeopener lecture on "Everything You Wanted to Know About Heat Shock Proteins But Were Afraid To Ask" and, as invited lecturer, spoke on "Structure and Function of hsc 70" at the 41st Annual Meeting of the Radiation Research Society and the 13th Annual Meeting of North American Hyperthermic Society, Dallas, March 21 - 26.

**Michael A. Mackey, Ph.D.**, assistant professor of radiology, presented "Long Duration Hyperthermia - Biological Rationale" at the 41st Annual Meeting of the Radiation Research Society, Dallas, March 19 - 25.

**Bruce L. McClennan, M.D.**, professor of radiology and chief of abdominal imaging, spoke on "Laparoscopic GU Surgery: What Do Radiologists Need to Know?" at the Society of Uroradiology, Naples, Florida, January 10 - 15. He presented "Contrast Media - Update 1993" and "Staging Renal Cell Carcinoma" at Sun Valley Imaging Course, Idaho, February 20 - 27. As visiting professor for the Grand Rounds Presentation, he lectured on "Contrast Reactions: Recognition and Treatment," Albany Medical Center, New York, March 9 - 10.

**Stephen M. Moerlein, Ph.D.**, associate professor of radiology, as invited lecturer, presented "PET Visualization of Serotonin Receptors" at the 140th Annual Meeting of the American Pharmaceutical Association, Dallas, March 20 - 24.

**William A. Murphy, M.D.**, professor of radiology and cochief of the musculoskeletal section, presented a series of midday lectures on "Forensic Radiology" and served as a panelist at the Film Reading Conference, 25th International Diagnostic Course, Davos, Switzerland, March 27 - April 2.

**Carlos A. Perez, M.D.**, professor of radiology and director of the Radiation Oncology Center, presented "Radiation Therapy and Chemotherapy in the Management of Carcinoma of the Uterine Cervix" at the Metropolitan Association of Radiation Oncologists and Physicists, Chicago, March 18.

**Joel S. Perlmutter, M.D.**, research associate professor of radiology and associate professor of neurology, spoke on "PET Investigations of Dystonia" at the National Institutes of Health Conference: Research into Dystonia, Bethesda, Maryland, February 16 - 17.

**James A. Purdy, Ph.D.**, professor of radiology and associate director of the Radiation Oncology Center, as a visiting professor, spoke on "Advances in 3-D Conformal Radiation Therapy" at Henry Ford Hospital, Detroit, December 3 - 4. As invited speaker, he presented "Status of 3-D Radiation Treatment Planning" at the National Library of Medicine Workshop, Washington, D.C.,

# FYI

## VISITING PROFESSORS & INVITED LECTURERS

*Continued from page 25*

December 15. Purdy also presented "Physics Aspects of 3-D CRT" to the Radiation Therapy Oncology Group, Scientific Symposium on 3-D Conformal Therapy, New Orleans, January 15 - 17.

**Henry D. Royal, M.D.**, associate professor of radiology and associate director of the Division of Nuclear Medicine, presented "Nuclear Medicine - GI" and "Nuclear Thyroidology" at the University of California, Resident Review Counsel, San Francisco, March 1 - 5. As invited speaker, he presented "Chernobyl: Perceptions and Realities" and "Radiation Risks: Scientific and Public Views" at the Eastern Great Lakes Chapter Society of Nuclear Medicine 14th Annual Meeting, Niagara-on-the-Lake, Ontario, March 5.

**Stuart S. Sagel, M.D.**, professor of radiology, chief of chest radiology, and cochief of computed body tomography, presented "CT of Mediastinal Masses," "CT in Lung Cancer," "CT in Asbestos-Related Thoracic Disease," and "CT of the Thorax: Technique, Anatomy, Pitfalls" at the Computed Body Tomography 1993 Course, The Cutting Edge, Orlando, February 4 - 7. He also spoke on "CT of Vascular Mediastinal Lesions," "HR CT of the Pulmonary Parenchyma," "CT in Bronchogenic Carcinoma," and "Chest Radiology: Low Tech to High Tech," at the Symposium in Diagnostic Imaging, Pittsburgh, March 11 - 13.

**Marilyn J. Siegel, M.D.**, professor of radiology, as visiting professor, lectured on "CT of the Pediatric Pelvis" and "Ultrasonography of Acute Abdominal Pain" at Wilford Hall, United States Air Force Medical Center, San Antonio, February 22 - 23. She presented "MRI of Bone Marrow" and "Imaging of the Pediatric Pelvis" at the 16th Annual Society of Computed Body Tomography and Magnetic Resonance Meeting, Orlando, March 1 - 5. Siegel spoke on "CT/MR of the Pediatric Mediastinum," "CT of Congenital Lung Anomalies," and "Ultrasonography of Acute Abdominal Pain in Children" at the University of California Postgraduate Diagnostic Radiology Course, San Francisco, March 22 - 26.

**Ali Soleimani-Meigooni, Ph.D.**, assistant professor of radiology, presented "Practical Quality Assurance Tests for Positional and Temporal Accuracy of HDR Remote Afterloaders" (coauthored with **Jeffrey Williamson, Ph.D.**, and **Eric Slessinger, M.S.**) at the American Endocurietherapy Society meeting, Beaver Creek, Colorado, December 8 - 11.

**Jeffrey F. Williamson, Ph.D.**, associate professor and chief of brachytherapy physics service, spoke on "Quality Assurance for High Dose-Rate Brachytherapy" and "New Developments in Basic Brachytherapy Physics," M.D. Anderson Cancer Center, University of Texas, Houston, December 14 - 15.

**Anthony J. Wilson, M.D.**, assistant professor of radiology, as visiting professor, spoke on "The Radiological Appearance of Chondromyxoid Fibroma" and "Musculoskeletal Digital Imaging" at the Society of Skeletal Radiology Annual Meeting, Marco Island, Florida, February 17 - 20. He presented ten lectures on "Musculoskeletal Magnetic Resonance Imaging" at the 25th International Diagnostic Course, Davos, Switzerland, March 27 - April 2.

## SYMPOSIA

### MIDWEST REGIONAL RADIATION RESEARCH

*The following Mallinckrodt Institute staff members participated in the Eighth Annual Meeting of Midwest Regional Radiation Research, St. Louis, November 21 - 22.*

**Clayton R. Hunt, Ph.D.** and **Joseph L. Roti Roti, Ph.D.** were members of the Program Committee.

**Joseph L. Roti Roti, Ph.D.**, presented "Opening Remarks" and "Closing Remarks" for the 1992 meeting.

### SYMPOSIUM II: Predictors of Radiation Response

**Andrei Laszlo, Ph.D.**, chairperson.

**Robert S. Malyapa, M.D., Ph.D.**; **William D. Wright, M.S.**; **Joseph L. Roti Roti, Ph.D.**, "Variation of Nuclear Protein Content and Chromatin Structure in Rodent Cells of Differing Radiosensitivity."

**Yvonne C. Taylor, Ph.D.**; **Azemat J. Parsian, B.S.**; "Differential Post-Irradiation Caffeine Response in Normal vs. SV40-Transformed Human Fibroblasts: Potential Role of Nuclear Organization and Protein Composition."

### SESSION I: "Heat-Shock Proteins and Genes

**Mingshun Chen, Ph.D.**; **Andrei Laszlo, Ph.D.**, "Molecular Cloning and Expression of hsc 70 in Chinese Hamster Cells."

**Clayton R. Hunt, Ph.D.**, "Structure of the Mouse HSP70 Gene Family."

**Andrei Laszlo, Ph.D.**; **An Hu, M.S.**; **Teri Davidson, M.A.**; **John Subject, Ph.D.\***, "Intracellular Localization of hsc 70 in Control and Heated Mammalian Cells." \*Roswell Park Institute, Buffalo, New York.

# FYI

## SESSION II: Modifiers of Radiation Response

**Michael A. Mackey, Ph.D.**,  
chairperson.

## SESSION III: Cellular Effects of Hyperthermia

**Clayton R. Hunt, Ph.D.**,  
chairperson.

**Michael A. Mackey, Ph.D.;**  
**Joseph L. Roti Roti, Ph.D.**,  
"Towards a Novel Thermal  
Dose Concept for Use in  
Clinical Hyperthermia  
Administration."

**Michael A. Mackey, Ph.D.;**  
**Andrei Laszlo, Ph.D.;**  
**Joseph L. Roti Roti, Ph.D.**,  
"Biochemical Mechanisms of  
p<sup>34</sup>-CDC2 Kinase Activation  
Associated with Spontaneous  
Premature Chromosome  
Condensation Induction in HeLa Cells  
Heated at 41.5°C."

**Joseph L. Roti Roti, Ph.D.;**  
**Nazan Turkel, M.S.**,  
"Analysis of Nuclear Protein  
Changes Following Heat  
Shock in Normal and Ther-  
motolerant (TT) HeLa Cells."

## RADIOLOGICAL SOCIETY OF NORTH AMERICA

*The following Mallinckrodt  
Institute staff members par-  
ticipated in the 78th Annual  
Scientific Assembly and  
Annual Meeting of the Radi-  
ological Society of North  
America, Chicago, Novem-  
ber 29 - December 5.*

**PLENARY SESSIONS**  
**Mokhtar Gado, M.D.**, panel  
member for the session on  
"Base of Skull Tumors."

## REFRESHER COURSES

**Dennis M. Balfe, M.D.;**  
**William E. Torres, M.D.\***,  
"Incidental Liver Lesion."  
\*Emory University, Atlanta.

**Harvey S. Glazer, M.D.;** **J.**  
**David Godwin II, M.D.\*;**  
**Robert D. Tarver, M.D.\*\***,  
"CT of the Lung, Medi-  
astinum, and Diaphragm."  
\*University of Washington,  
Seattle. \*\*Indiana University  
Medical Center, Indianapolis.

**Marshall E. Hicks, M.D.;**  
**Thomas O. McNamara,**  
**M.D.\***, "Percutaneous Trans-  
luminal Angioplasty and Fibrin-  
olysis." \*University of  
California, Los Angeles.

**William H. McAlister,**  
**M.D.;** **Alan S. Brody,**  
**M.D.\***, "Pediatric Imaging:  
Paranasal Sinuses and Nasal  
Cavities." \*Department of  
Radiology, Children's  
Hospital of Buffalo.

**Jeff M. Michalski, M.D.;**  
**John W. Wong, Ph.D.\***,  
"Real-Time Portal Imaging."  
\*William Beaumont Hospital,  
Royal Oak, Michigan.

**William A. Murphy, M.D.**,  
"Forensic Radiology:  
Techniques for Death  
Investigation."

**Robert J. Myerson, M.D.;**  
**Leonid B. Leybovich,**  
**Ph.D.\***, "Current Trends in  
Improving the Efficiency of  
Hypothermia Combined with  
Radiation Therapy." \*Loyola  
Medical Center, Naperville,  
Illinois.

**Daniel Picus, M.D.;** **Gerald**  
**Zemel, M.D.\*;** **Eric Martin,**  
**M.D.\*\***, "Advances in Hepa-  
tobiliary Intervention."  
\*Miami Vascular Institute,  
Miami. \*\*Columbia-Presby-  
terian Medical Center, New  
York.

**Henry D. Royal, M.D.**,  
"Effects of Low-Level Radia-  
tion: Scientific, Political,  
and Social Views."

**Stuart S. Sagel, M.D.;**  
**Elliot K. Fishman, M.D.\*;**  
**Patrick F. Sheedy, M.D.\*\***;  
"Fast CT Scanning: Clinical  
Applications of Spiral and  
Electron-Beam CT."  
\*Department of Radiology,  
Johns Hopkins Hospital, Bal-  
timore. \*\*Department of  
Diagnostic Radiology, Mayo  
Clinic, Rochester.

## WORKSHOPS

**Kevin Burton, M.D.;**  
**Kenyon K. Kopecky,**  
**M.D.\***, "How to Perform Per-  
cutaneous Nephrostomy and  
Antegrade Ureteral Stent  
Placement (How-to Work-  
shop)." \*Department of  
Radiology, Indiana University  
Medical Center, Indianapolis.

**William D. Middleton,**  
**M.D.;** **Phillip W. Ralls,**  
**M.D.\*;** **Ronald R.**  
**Townsend, M.D.\*\*;** **Kevin**  
**P. Lee, CRT, RDMS\*;** **Lau-  
rence A. Mack, M.D.\*\*\***,  
"Practical Abdominal Color  
Doppler Sonography (Hands-  
on Workshop)." \*University  
of Southern California -

Los Angeles Campus Medical  
Center. \*\*Division of Body  
Imaging, University of Col-  
orado Health Sciences Cen-  
ter, Denver. \*\*\*Department  
of Radiology, University  
of Washington School of  
Medicine, Seattle.

**William D. Middleton,**  
**M.D.**, "US of Small but Not  
Insignificant Parts - Testis  
and Scrotum."

## SCIENTIFIC SESSIONS

**William D. Middleton,**  
**M.D.;** **et al\***, "Testicular  
Microlithiasis: Imaging  
Appearances and Pathologic  
Correlation." \*Multi-institu-  
tional presentation with con-  
tributing authors from  
Department of Radiology,  
University of Washington  
School of Medicine, Seattle,  
and Department of Diagnos-  
tic Radiology, Mayo Clinic,  
Rochester.

**James A. Brink, M.D.;**  
**Michael W. Vannier, M.D.;**  
**Jay P. Heiken, M.D.;**  
**William A. Kalender,**  
**Ph.D.\*;** **Roberta L. Yoffie,**  
**R.T.;** **Barry S. Brunsten,**  
**research engineer**,  
"Abdominal Spiral CT:  
Effect of Interpolation Algo-  
rithm, Collimation, and  
Zoom on Effective Section  
Thickness and Noise."  
\*Siemens Medical Systems,  
Inc., Erlanger, Germany.

**James A. Brink, M.D.**,  
presider, "Genitourinary  
(Infertility and Adrenal  
Imaging)."

# FYI

## SYMPOSIA

*Continued from page 27*

**James A. Brink, M.D.;** **Jay P. Heiken, M.D.;** **Bruce L. McClelland, M.D.;** **Dennis M. Balfe, M.D.;** **Stuart S. Sagel, M.D.;** **Michael W. Vannier, M.D.,** "Clinical Utility of Postprocessing for Spiral Abdominal CT."

**James A. Brink, M.D.;** **Jay P. Heiken, M.D.;** **Dennis M. Balfe, M.D.;** **Jeffrey J. Brown, M.D.;** **Joseph A. Borrello, M.D.;** **Michael W. Vannier, M.D.;** et al., "Non-invasive Cholangiography with Spiral CT."

**Michael D. Darcy, M.D.;** **Larry D. Dalan, M.D.\*;** **Michael A. Burns, M.D.;** **Kevin E. Burton, M.D.;** **Scott D. Stevens, M.D.\*\*;** **Michael A. Kleinhoffer, R. T.;** et al., "Detection of Hemodynamically Significant Iliac Artery Stenoses: Comparison of Angiography and Intravascular US." \*St. John's Mercy Medical Center, St. Louis. \*\*Central Baptist Hospital, Lexington.

**Lane A. Deyoe, M.D.;** **John J. Cronan, M.D.\*;** **Brian H. Breslaw, M.D.\*;** **Mark S. Ridlen, M.D.\*,** "New US and Color Doppler Techniques for the Prospective Evaluation of Acute Renal Obstruction." \*Diagnostic Imaging, Rhode Island Hospital, Providence.

**James B. Duncan, M.D., Ph.D.,** "MR Contrast Agents Targeted to Mannose 6-Phosphate Receptors: In Vitro Testing."

**Howard P. Forman, M.D.;** **William D. Middleton, M.D.;** **G. Leland Melson, M.D.;** **Bruce L. McClelland, M.D.,** "Increasing Frequency of Hyperechogenic Small Renal Cell Carcinoma."

**Howard P. Forman, M.D.;** **Lee A. Fox, B.S. (medical student);** **Harvey S. Glazer, M.D.;** **Dixie J. Anderson, M.D.;** **Bruce L. McClelland, M.D.;** **Stuart S. Sagel, M.D.,** "Role of Routine Chest Radiographs for Prostate Carcinoma in the New Era of Health Cost Containment."

**Harvey S. Glazer, M.D.,** presider, "Chest (High-Resolution CT: Airways and Emphysema)."

**Dale P. Harris, M.D.;** **Jay P. Heiken, M.D.;** **James A. Brink, M.D.;** **Dennis M. Balfe, M.D.;** **Michael D. Darcy, M.D.;** **Dixie J. Anderson, M.D.,** "Normal Abdominal Anatomy and Abdominal Complications After Lung Transplantation with Omental Wrapping."

**Jay P. Heiken, M.D.,** presider, "Gastrointestinal (MR Abdomen)"

**Marshall E. Hicks, M.D.;** **Eric S. Malden, M.D.;** **Daniel Picus, M.D.;** **Michael D. Darcy, M.D.;** **Thomas M. Vesely, M.D.;** **Michael A. Kleinhoffer, R.T.;** et al., "Fluoroscopically Guided Percutaneous Gastrostomy with a 14-F Cope Type Gastrostomy Tube: Analysis of 265 Consecutive Cases."

**Lisa S. Langmo, M.D.\*;** **Azar P. Dagher, M.D.\*;** **William B. Mehard, M.D.;** **William C. Small, M.D., Ph.D.\*;** **Jay P. Heiken, M.D.;** **Elliot K. Fishman, M.D.\*;** et al., "Does CT Arterial Portography Before Hepatic Resection Improve Patient Survival Rates?" \*Department of Radiology, Johns Hopkins Hospital, Baltimore.

**Kevin W. McEnery, M.D.;** **Anthony J. Wilson, M.B., ChB.;** **William A. Murphy, M.D.;** **Michael M. Marushack, M.D.\*,** "Spiral CT Imaging of the Musculoskeletal System: A Phantom Study." \*Department of Surgery, Washington University, St. Louis.

**L. Santiago Medina, M.D.;** **Marilyn J. Siegel, M.D.;** **Pablo A. Bejarano, M.D.\*;** **Harvey S. Glazer, M.D.;** **Dixie J. Anderson, M.D.,** "Pediatric Lung Transplantation: Radiographic-Pathologic Correlation." \*Pathology Department, Washington University, St. Louis.

**L. Santiago Medina, M.D.;** **Henry D. Royal, M.D.;** **Elbert P. Trulock, M.D.\*;** **Neil A. Ettinger, M.D.\*,** "Postoperative Evaluation of Single-Lung Transplant Patients with Quantitative Ventilation-Perfusion Imaging." \*Department of Internal Medicine, Washington University, St. Louis.

**William B. Mehard, M.D.;** **Jay P. Heiken, M.D.;** **Gregorio A. Sicard, M.D.\*,** "High Attenuation Crescent in Abdominal Aortic Aneurysm Wall at CT: Sign of Acute or Impending Rupture." \*Department of Surgery, Washington University, St. Louis.

**Viktor M. Metz, M.D.\*;** **Frederick A. Mann, M.D.;** **Louis A. Gilula, M.D.,** "Three-compartment Arthrography: Correlation of Wrist Pains with Uni- and Bidirectional Communications." \*Department of Radiology, University of Vienna School of Medicine, Vienna.

**Cynthia F. Morrison, M.D.;** **Benjamin C. P. Lee, M.D.,** "SE and Inversion Techniques in Evaluation of the White Matter in Cerebral Palsy."

**Robert J. Myerson, M.D.;** **Elisa Birnbaum, M.D.\*;** **James W. Fleshman, M.D.\*;** **Robert D. Fry, M.D.\*;** **Ira J. Kodner, M.D.\*;** **Jeff M. Michalski, M.D.,** "Preoperative Radiation Therapy for Rectal Carcinoma Judged to be Stage T3 or T4 at Transrectal US." \*Department of Surgery, Jewish Hospital of St. Louis.

**William H. Perman, Ph.D.;** **Mohkhtar H. Gado, M.D.,** "In Vivo Relationship between GD-DTPA Concentration and R<sub>2</sub> for Brain Parenchyma and Arterial Blood."

**James V. Piephoff, M.D.;** **Todd H. Wasserman, M.D.;** **Eric E. Klein, M.S.;** **Elizabeth Miller, B.A. (medical student);** **Nancy Kucik, clinical research associate;** **Barbara S. Monsees, M.D.,** "Increased Risk of Breast Cancer in Women with Hodgkin's Disease."

# FYI

Thomas K. Pilgram, Ph.D.; Michael W. Vannier, M.D.; Jeffrey L. Marsh, M.D.\*; Mokhtar H. Gado, M.D.; William H. McAlister, M.D.; Christopher J. Moran, M.D.; Gary D. Shackelford, M.D.; et al., "Craniosynostosis: Binary Nature and Radiographic Identifiability of the Abnormality." \*Department of Surgery, Washington University, St. Louis.

Hashim S. Raza, M.D.; Jeffrey J. Brown, M.D.; Joseph A. Borrello, M.D.; Dennis M. Balfe, M.D., "Dynamic Contrast-enhanced MR Imaging of the Liver: Transient Hepatic Signal Intensity Differences."

Robert D. Reinhart, M.D.\*; Joseph A. Borrello, M.D.; James A. Brink, M.D.; Glenn J. Foster, R.T.; Jeffrey J. Brown, M.D., "MR Cholangiography: Optimization of Imaging Parameters with Liver Phantom." \*Bethlehem General Hospital, Bethlehem, Pennsylvania.

Cynthia K. Rigsby, M.D.; Marilyn J. Siegel, M.D., "Normal CT Appearance and Measurements of the Pediatric Ovaries and Uterus."

Henry D. Royal, M.D.; Elbert P. Trulock, M.D.\*; Neil A. Ettinger, M.D.\*, "Effects of Ischemic Time on Relative Perfusion and Ventilation in Double-Lung Transplant Patients." \*Department of Internal Medicine, Washington University, St. Louis.

Maria E. Schmidt, M.D.; Marilyn J. Siegel, M.D., "Posterior Urethral Valves: Spectrum of Sonographic Appearances."

Janice W. Semenkovich, M.D.; Harvey S. Glazer, M.D.; Dixie J. Anderson, M.D.; Elbert P. Trulock, M.D.\*; Joel D. Cooper, M.D.\*\*; Stuart S. Sagel, M.D., "Bronchial Dehiscence in Lung Transplants: CT Evaluation." \*Department of Internal Medicine, Washington University, St. Louis. \*\*Department of Surgery, Washington University, St. Louis.

Kevin L. Shady, M.D.; Marilyn J. Siegel, M.D.; Jeffrey Brown, M.D., "Diagnosis of Intraabdominal Vascular Abnormalities in Children with SE and Flash MR Imaging."

Hui Hua Shu, M.D.; Jeffrey J. Brown, M.D.; Joseph A. Borrello, M.D.; Scott A. Mirowitz, M.D.; Gino DiIorio, M.D., Ph.D.; Fernando R. Gutierrez, M.D., "MR Imaging of Primary Pulmonary Hypertension Before and After Single Lung Transplantation: Qualitative and Quantitative Analysis."

Barry A. Siegel, M.D., president, "Nuclear Medicine (PET)."

Marilyn J. Siegel, M.D.; Shawn P. Quillin, M.D., "Color Doppler Sonography in Appendicitis in Childhood."

Kurt R. Simpson, M.D.; Dennis M. Balfe, M.D.; Edward Muka, Ph.D.; James A. Brink, M.D.; Sharlene Teefey, M.D.; Charles F. Hildebolt, D.D.S., Ph.D.; Thomas K. Pilgram, Ph.D., "Optimal Cholangiography: Assessment with Digital Techniques."

William C. Small, M.D., Ph.D.\*; William B. Mehard, M.D.; Lisa S. Langmo, M.D.\*; Azar P. Dagher, M.D.\*; Elliot K. Fishman, M.D.\*; Jay P. Heiken, M.D.; et al., "Predictive Assessment of Malignant Hepatic Tumor Resectability with CT Portography." \*Department of Radiology, Johns Hopkins Hospital, Baltimore.

Nhan P. Truong, M.D.; Frederick A. Mann, M.D.; Louis A. Gilula, M.D.; Si-Won Kang, M.D.\*, "Radiographic Wrist Instability Series: When Is It of Value?" \*Department of Radiology, Dae-Jeon St. Mary's Hospital, Catholic University Medical College, Dae-Jeon, Korea.

Todd W. Wasserman, M.D., president, "Radiation Oncology (Lymphoma)."

Anthony J. Wilson, M.B., Ch.B.; Frederick A. Mann, M.D.; O. Clark West, M.D.; Kevin W. McEnery, M.D.; William A. Murphy, M.D., "Storage-Phosphor Imaging of the Cervical Spine: Comparison with Conventional Radiography by Using a Hybrid Cassette."

## SCIENTIFIC EXHIBITS

Brian H. Breslaw, M.D.\*; Lane A. Deyoe, M.D.; John J. Cronan, M.D.\*; Mark S. Ridlen, M.D.\*, Certificate of merit for "Comparison of Urography and Color Doppler US Including Ureteral Jet Assessment in Patients with Suspected Acute Renal Obstruction." \*Diagnostic Imaging, Rhode Island Hospital, Providence.

Kevin E. Burton, M.D.; Daniel Picus, M.D.; Marshall E. Hicks, M.D.; Michael D. Darcy, M.D.; Thomas M. Vesely, M.D.; Michael A. Kleinhoffer, R.T., Certificate of merit for "Fragmentation of Biliary Calculi with Intracorporeal Electrohydraulic Lithotripsy before Percutaneous or Endoscopic Stone Removal."

Eric S. Malden, M.D.; Marshall E. Hicks, M.D.; Daniel Picus, M.D.; Michael D. Darcy, M.D.; Thomas M. Vesely, M.D., Certificate of merit for "Percutaneous Gastrostomy: Technique and Results in 265 Consecutive Patients with the Mallinckrodt Institute Gastrostomy Set."

Kevin W. McEnery, M.D.; Frederick A. Mann, M.D.; William A. Murphy, M.D.; Edward Muka, M.S.E., "Emergency Room Fascicle: Cervical Spine."

Kevin W. McEnery, M.D.; Anthony J. Wilson, M.B., Ch.B.; William A. Murphy, M.D.; Michael M. Marushack, M.D.\*, "Spiral CT Imaging of the Musculoskeletal System." \*Department of Surgery, Washington University, St. Louis.



# FYI

## SYMPOSIA

*Continued from page 29*

**Rachel F. Oser, M.D., Judy M. Destouet, M.D.; Barbara S. Monsees, M.D.; Tracy L. Roberts, M.D.,** Certificate of merit for "Imaging the Augmented Breast."

**Shawn P. Quillin, M.D.; Marilyn J. Siegel, M.D.,** *cum laude* award for "Color Doppler Sonography of Acute Lower Abdominal Pain."

**Hui Hua Shu, M.D.; Scott A. Mirowitz, M.D.; Franz J. Wippold, M.D.,** "Craniospinal MR Imaging in Neurofibromatosis."

### INFORAD EXHIBITS

**G. James Blaine, D.Sc.; Jerome R. Cox, Sc.D.\*; R. Gilbert Jost, M.D.,** "High Speed Network (Local Area Wide Area) Support for Electronic Radiology." \*Computer Science Department, Washington University, St. Louis.

**Jan D. Durham, M.D.\*; Anthony C. Venbrux, M.D.\*\*; Michael D. Darcy, M.D.; Jeanne M. LaBerge, M.D.\*\*\*,** "CIRREF Videodisk II - Portal Hypertension: Diagnosis and Treatment." \*University of Colorado, Denver. \*\*Johns Hopkins Hospital, Baltimore. \*\*\*University of California, San Francisco.

**R. Gilbert Jost, M.D.; G. James Blaine, D.Sc.; Stephen M. Moore, D.Sc.,** "ACR-NEMA Prototype Standard Demonstration."

**Kevin W. McEnery, M.D.; Fred A. Mann, MD.; William A. Murphy, M.D.; Edward Muka, M.S.E.,** "Emergency Room Fascicle: Cervical Spine."

## HONORS/ AWARDS

**Robert S. Malyapa, M.D., Ph.D.,** research associate in cancer biology, received the Radiation Research Society Travel Award to attend the Society's 41st Annual Meeting in Dallas, March 20 - 25.

## ALUMNI NEWS

**Alvin Korba, M.D.,** medical director of the Evansville (Indiana) Cancer Center and former MIR resident, received the 1992 *Kurt Sauerwein Award* at the 7th International Brachytherapy Conference in Luzern, Switzerland, in May, 1992. Dr. Korba is a pioneer in HDR brachytherapy with the GAMMAMED and, starting in early 1984, was one of the first physicians in the United States to aggressively treat lung cancer with HDR brachytherapy.

## APPOINTMENTS/ ELECTIONS

**Franz J. Wippold, M.D.,** assistant professor of radiology, was appointed clinical associate professor of radiology and nuclear medicine at the Uniform Services University of the Health Sciences, Bethesda, Maryland. He presents yearly courses in radiology at the National Naval Medical Center and at Walter Reed Army Medical Center as well as collaborates on research projects at the Armed Forces Institute of Radiology.

## CALENDAR

### April 14 - 18, 1993

Society of Breast Imaging  
Amelia Island, Florida

### April 21 - 23, 1993

3D Radiation Treatment  
Planning and Conformal  
Therapy: An International  
Symposium  
Sheraton Westport Inn  
St. Louis

### April 24 - 28, 1993

75th Annual Meeting of the  
American Radium Society  
Aruba

### April 25 - 30, 1993

93rd Annual Meeting of the  
American Roentgen Ray  
Society  
San Francisco

### April 27, 1993

American Association of  
Women Radiologists  
San Francisco

### April 29, - May 1, 1993

American College of Medical  
Physicists Annual Meeting  
Destin, Florida

### May 9 - 13, 1993

Radiology Business Manage-  
ment Association  
Las Vegas

### May 13 - 16, 1993

Society for Pediatric  
Radiology  
Seattle

### May 16 - 21, 1993

American Society of  
Neuroradiology  
Vancouver

### May 19 - 21, 1993

Third International  
Brachytherapy and Remote  
Afterloading Symposium and  
Workshop  
Hyatt Regency Hotel  
St. Louis

### June 21 - 25, 1993

International Congress of  
Radiation Oncology 1993  
Kyoto

# FYI



The MIR Alumni Reception at the 78th Annual Meeting of RSNA, November 30, 1992



Above: (left to right) Joseph K. T. Lee, M.D.; Bill Berkman, M.D.; and Tony Merlis, M.D.

Far Left: (left to right) R. Gilbert Jost, M.D.; James Blakely, M.D.; and Matt Powers, M.D.

Left: (left to right) David Davis, M.D.; Edward Kotlyarov, M.D.; and Michel M. Ter-Pogossian, Ph.D.



Above: Robert Stanley, M.D. (left), and Jim Winthrop, M.D.

Left: (left to right) Dan Malter, M.D.; Alexander Margulis, M.D.; and Ronald G. Evens, M.D.

# REFLECTIONS

## IN REMEMBRANCE

*Our dear friend and colleague G. Leland (known by all as Lee) Melson, M.D., died on November 10, 1992, following a courageous five-month battle against cancer. In his more than 20 years at Mallinckrodt Institute of Radiology, Dr. Melson, a professor of radiology, head of ultrasonography, and an accomplished teacher, earned the admiration and respect of his colleagues and peers. He was widely known for his expertise in the areas of abdominal radiology and ultrasound.*

*On January 4, 1993, in MIR's Scarpellino Auditorium, a gathering of family, friends, and colleagues shared special remembrances of this warm and caring man. In Dr. Melson's honor and as a lasting tribute to him, the Institute established a visiting professor fund that will bring to MIR those individuals whose philosophy and style of teaching most reflect that of Lee Melson's.*

*The following excerpt from that memorial tribute was presented by Bruce L. McClennan, M.D., professor of radiology and chief of abdominal radiology.*

The testimony or tribute to the worth of a man is the feeling that one has when leaving his presence. Remembrance is a good form of mourning, but to be recognized and appreciated and loved in life is really the best memorial of all. This indeed was the case for Lee Melson. Death in its wake leaves an intense, palpable pain that we all have felt and still feel. Collective remembrances such as this help us all to bear the pain of passing and turn it towards the future, as an energy for renewal and guidance to face the new and unforeseen challenges to our practices and in our lives. ... Though nature took one so special from among us, the nurturing spirit that he possessed will be felt by us all in our practice and daily family lives.

Countless patients, students, residents, ultrasound technologists, fellows, referring physicians, and radiologists have benefitted by their exposure to Lee Melson. He was a quiet and thoughtful man

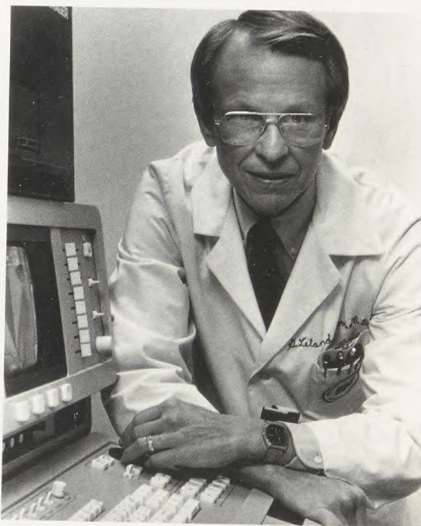

who was an extremely effective teacher, with a tireless patience in his pursuit of truth and excellence. He had a determination and true devotion to the real work that is the diagnostic process of imaging, especially ultrasonography. He believed education was a shared experience, one which was never complete. Lee prided himself in the talent he possessed, and displayed daily, for teaching all of us. "No" was not a word in his vocabulary when it came to helping others. His sense of commitment remains a model for us all. The establishment of an endowment fund in his name and in his honor will perpetuate that ideal.

Over the years, he and I had several heart-to-heart conversations, many of which ended with a hug. We touched on very personal and difficult issues of choices in our professional careers and our family lives. We encouraged each other and supported our respective choices. I continually stressed how valuable, if not critical, he was to our abdominal radiology section. So, he will be missed by me in ways too numerous to count, for he was a willing ally in the battles and challenges that our practice here at Washington University encounters. He was a wise, generous, and gracious counsel; a consummate example of what a radiologist should be and, more importantly, how one should behave. He was a

friend at my office door, waiting eagerly to tell me a joke and always beginning his hearty laugh just before the punch line; or, at the door of my home when I or my family needed him. But, best of all, he was my friend, there at my side. ...

With these words, I speak for [Doctors] Jay [Heiken], Bill [Middleton], Dennis [Balfes], Jim [Brink], and Sherry [Teefey] and all our many fellows who have and will continue to carry on the traditions and the spirit of Lee in their lives and careers. We are all excited about the endowment in Lee's honor that you all have helped create for him and we pledge to carry out what I know would be his wishes for it.

A couple of years ago I wrote a poem one cold fall morning while down at Lake of the Ozarks. I had put it away only to find it this past November. I can't actually remember the thoughts or feelings that drove me to write it, but with some modification, it now captures what I have tried to say here this evening. I hope in sharing it with you, it will help you in remembrance of him.

### The Life We Leave

And the morning sun touched those  
leaves,  
as brown as toast,  
on that tree out front,  
the one I loved most.  
Leaves seemed in such a rush as if  
they knew,  
from which branch,  
on which breeze they flew.  
Yet, each near barren branch gets  
its chance,  
like sparks flee the flame  
none are ever quite the same.  
Each on its own such a short time  
they climb and float,  
until the cold, and light now dim  
brings each to rest,  
and end,  
this quote.



*In 1986, Mallinckrodt Institute of Radiology developed one of the first and most effective mobile screening-mammography programs in the Midwest area. In the subsequent years, the original blue-and-silver van became a familiar sight around the metro-St. Louis area. As a result, more than 40,000 women were screened for breast cancer. In late 1992, a newer version of the mammography van made its debut, complete with an interpretation of Claude Monet's "The Poppy Field." Sponsored by Barnes Hospital in conjunction with MIR, the van demonstrates an ongoing commitment to the fight against breast cancer.*

# FOCAL SPOT

MALLINCKRODT INSTITUTE OF RADIOLOGY

**MIR**  
MALLINCKRODT  
INSTITUTE OF RADIOLOGY  
WASHINGTON UNIVERSITY  
MEDICAL CENTER

*Administrator*  
Planning, Marketing and Public Relations  
Virginia Trent

*Editor*  
Vicki Kunkler

*Design*  
Purviance & Company  
Marketing Communications

*Contributing Writers*  
Cliff Froehlich  
Ramona "Lisa" Simmons

*Photographers*  
Mike DeFillippo  
T. Mike Fletcher  
Mike Simane  
Cliff Willis  
Thomas Murry  
Michelle Wynn

**Focal Spot** magazine is published three times a year by the Mallinckrodt Institute of Radiology at the Washington University Medical Center at 510 South Kingshighway, St. Louis, MO 63110.

Permission is granted to reproduce articles contained herein, provided **Focal Spot** magazine of the Mallinckrodt Institute of Radiology at the Washington University Medical Center is credited.

Public Relations Department  
Mallinckrodt Institute of Radiology  
510 South Kingshighway  
St. Louis, MO 63110  
(314) 362-2866

© Mallinckrodt Institute of Radiology, 1993

Address Correction Requested

ARCHIVES  
SERIALS DEPT., MEDICAL LIBRARY  
WASH. U. SCHOOL OF MEDICINE  
CAMPUS BOX 8132  
ST. LOUIS, MO 63110

Non-Profit Organization  
U.S. Postage  
PAID  
St. Louis, Missouri  
Permit No. 1032