

2017

## The impact of communication satisfaction on paediatric nurses' job satisfaction and intention to stay

Gemma Doleman  
*Edith Cowan University*

Follow this and additional works at: <https://ro.ecu.edu.au/theses>



Part of the [Human Resources Management Commons](#), and the [Nursing Commons](#)

---

### Recommended Citation

Doleman, G. (2017). *The impact of communication satisfaction on paediatric nurses' job satisfaction and intention to stay*. <https://ro.ecu.edu.au/theses/2022>

This Thesis is posted at Research Online.  
<https://ro.ecu.edu.au/theses/2022>

# Edith Cowan University

## Copyright Warning

You may print or download ONE copy of this document for the purpose of your own research or study.

The University does not authorize you to copy, communicate or otherwise make available electronically to any other person any copyright material contained on this site.

You are reminded of the following:

- Copyright owners are entitled to take legal action against persons who infringe their copyright.
- A reproduction of material that is protected by copyright may be a copyright infringement. Where the reproduction of such material is done without attribution of authorship, with false attribution of authorship or the authorship is treated in a derogatory manner, this may be a breach of the author's moral rights contained in Part IX of the Copyright Act 1968 (Cth).
- Courts have the power to impose a wide range of civil and criminal sanctions for infringement of copyright, infringement of moral rights and other offences under the Copyright Act 1968 (Cth). Higher penalties may apply, and higher damages may be awarded, for offences and infringements involving the conversion of material into digital or electronic form.

---

# **The Impact of Communication Satisfaction on Paediatric Nurses' Job Satisfaction and Intention to Stay**

This thesis is presented for the degree of

Doctor of Philosophy

Gemma Doleman)

Edith Cowan University

School of Nursing and Midwifery

2017

---

# ABSTRACT

Effective communication is the most central process within an organisation and is essential to organisational values, norms and expectations. There is a documented connection between job satisfaction, work commitment and organisational communication. However, nurses' and nursing middle managers' satisfaction with organisational communication has not been extensively studied in recent years and not at all among paediatric nurses. Therefore, the purpose of this study was to develop and test a theoretical model that examined paediatric nurses' and middle managers' satisfaction with organisational communication and the effect this has on paediatric nurses' job satisfaction and intention to stay in their job.

Employing a quantitative research design, a series of surveys were distributed to paediatric nurses (including middle managers) in both electronic and hard copy formats. A total of 165 surveys were returned for a response rate of 42.4%. A Mann-Whitney U test was used to identify the difference in organisational communication perceptions between paediatric nurses and middle managers. A statistically significant difference was identified, with middle managers displaying greater dissatisfaction in seven communication satisfaction areas.

Structural Equation Modelling tested and refined the hypothesised model. Final analysis showed adequate fit data ( $\chi^2=2.040$ ,  $p$  value= .728, SRMR= .0302, CFI=1.00, RMSEA=.000, pCLOSE= .827). In the final model, supervisor relationships, media quality and communication climate had a direct effect on job satisfaction and an indirect effect on intention to leave ones' job and looking for another job. Job satisfaction had a direct effect on intention to leave and looking for another job. Study findings suggest that changes to upward and downward communication systems are needed to improve the nursing voice within healthcare organisations. In addition, more support and guidance is required for middle managers, including mentorship and intense training programs. Likewise, organisational communication education at the undergraduate level is needed for student nurses to develop the skills necessary to challenge weaknesses in communication once graduated.

---

# DECLARATION

I certify that this thesis does not, to the best of my knowledge and belief:

- (i) incorporate without acknowledgement any material previously submitted for a degree or diploma in any institution of higher education;
- (ii) contain any material previously published or written by another person except where due reference is made in the text of this thesis; or
- (iii) contain any defamatory material.

I also grant permission for the Library at Edith Cowan University to make duplicate copies of my thesis as required.

Signature: \_\_\_\_\_

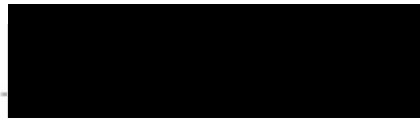

Date: \_\_\_\_\_

9<sup>th</sup> October 2017

---

# ACKNOWLEDGEMENTS

I wish to thank all who have helped me complete this research. Firstly, my supervisors Professor Di Twigg and Dr Sara Bayes. Their guidance, invaluable feedback, encouraging words and unwavering support have kept me going through the PhD journey. It has been a privilege to be supervised by two well researched academics. I have learnt a wealth of knowledge from them both.

I would a like to thank Dr Nick Gibson for his help getting through ethics in the early phase of the dissertation. Also, a big thank you to Dr Joyce Imna who took me under her wing and guided me through the Structural Equation Modelling process.

To the clinical and non-clinical nurses at Princess Margaret Hospital, thank you for taking the time to participate and offer support. Without them this study would still be an idea.

My wonderful family: Thank you for your continual support. To my mum, who has always encouraged and supported me throughout my studies. I couldn't have done it without you-thank you. To my dad, who I spent hours discussing my ideas with over the phone. Thank you for always listening. To my in-laws, Deb and Joe, who have watched my two beautiful girls so I could study, thank you for your support and encouragement.

A big thank you to my late grandfather whose last words were "never stop learning". It is because of these words that I have continued to study and have completed this dissertation. I know you would be proud.

To my Nan and John thank you for always showing support of my studies. Nan, thank you for the hours of nursing conversations we have had. It is because of you that I have developed a keen interest in change within the nursing profession. To my granddad Fox thank you for always showing support. I really appreciate it.

Finally, my two beautiful girls: Amelia and Willow, who have lost me to my university studies for the last few years. I could not have completed this journey without your support, guidance and continual love.

---

# TABLE OF CONTENTS

<b>ABSTRACT</b> .....	<b>i</b>
<b>DECLARATION</b> .....	<b>ii</b>
<b>ACKNOWLEDGEMENTS</b> .....	<b>iii</b>
<b>TABLE OF CONTENTS</b> .....	<b>iv</b>
<b>LIST OF TABLES</b> .....	<b>xi</b>
<b>LIST OF FIGURES</b> .....	<b>xiv</b>
<b>CHAPTER 1: INTRODUCTION</b> .....	<b>1</b>
Introduction.....	1
Background.....	1
Significance and purpose.....	2
Aims.....	3
Research questions.....	4
Hypotheses testing .....	4
Anticipated outcomes .....	4
Methodology overview .....	5
Thesis overview .....	5
Definitions of terms .....	6
Summary.....	8
<b>CHAPTER 2: LITERATURE REVIEW</b> .....	<b>9</b>
Introduction.....	9
Organisational structures .....	9
Mechanistic structure .....	10
Organic structure.....	11
Healthcare structures and design.....	11
Communication.....	12
Communication in nursing.....	13
Organisational communication .....	14
Directions of organisational communication in a hierarchical structure .....	14
Organisational communication in the healthcare setting .....	15
Systematic review .....	17

Aim .....	17
Review question development.....	17
PICOS statement .....	17
PICO statement.....	18
Research review questions.....	18
Design and search methods .....	18
Inclusion and exclusion criteria.....	19
Screening .....	20
Data extraction and quality appraisal .....	21
Results .....	38
Search results .....	38
Summary of quantitative quality review.....	38
Summary of qualitative papers .....	39
Summary of findings .....	40
Discussion.....	43
Implications for nursing practice .....	44
Implications for nursing research.....	45
Limitations.....	45
Systematic review conclusions.....	46
Summary.....	46
<b>CHAPTER 3: METHODS AND MATERIALS .....</b>	<b>48</b>
Introduction.....	48
Study design .....	48
Theoretical model .....	49
Research questions and hypothesis.....	50
Hypotheses .....	52
Intention to leave .....	52
Job satisfaction.....	53
Looking for a new job.....	53
Interaction hypothesis .....	54
Data collection techniques.....	54
Sampling framework .....	55
Sampling approach.....	55
Sample size .....	56



Surveys .....	58
Reliability .....	59
Data collection procedures .....	59
Data preparation and screening .....	60
Type of collected data .....	60
Missing data .....	60
Outliers.....	61
Distribution normality.....	61
Linearity.....	62
Multicollinearity .....	64
Data analysis techniques.....	64
Measurement model.....	65
Confirmatory Factor Analysis .....	65
Model fit .....	66
Structural Equation Modelling .....	67
Ethical considerations.....	67
Summary.....	68
<b>CHAPTER 4: DEMOGRAPHIC AND CONTEXTUAL RESULTS .....</b>	<b>69</b>
Introduction.....	69
Survey response rate .....	69
Response bias.....	70
Sample demographics .....	72
Participant's position .....	72
Participant's gender .....	73
Participant's age.....	74
Participant's highest level of education .....	75
Participant's employment status .....	75
Participant's area of work .....	75
Number of years in current role .....	76
Communication satisfaction differences based on level of education, years of nursing and managerial experience, contracted hours, area of work, age and gender .....	77
Communication satisfaction between paediatric nurses and middle managers with different educational levels.....	77

Communication satisfaction between paediatric nurses and middle managers with different years of nursing and managerial experience .....	78
Communication satisfaction between ward nurses and middle managers with different contract hours .....	80
Communication satisfaction between paediatric nurses and middle managers from different specialty areas.....	81
Communication satisfaction between paediatric nurses and middle managers with different ages and gender .....	83
Job satisfaction.....	85
Paediatric nurses intention to leave .....	93
Descriptive results .....	95
Data preparation and screening .....	95
Multicollinearity .....	95
Outlier .....	98
Mann-Whitney U Test .....	98
Information about my progress in my job.....	99
Extent to which my supervisor listens and pays attention to me .....	100
Extent to which my supervisor offers guidance for solving job related problems .....	101
Extent to which the amount of supervision given me is about right.....	102
Extent to which the people in my organisation have great ability as communicators .....	103
Extent to which informal communication is accurate and active .....	104
Extent to which the attitudes toward communication in the organisation are basically healthy .....	105
Summary.....	105

## **CHAPTER 5: PHASE 1 STRUCTURAL EQUATION MODELLING**

<b>RESULTS .....</b>	<b>107</b>
Introduction.....	107
Hypothesised conceptual model .....	107
Measurement model.....	108
Model fit.....	108
Congeneric Factor Analysis .....	109
Organisational integration .....	109
Corporate perspective .....	111
Communication climate.....	113

Supervisor relationships.....	115
Media quality .....	117
Horizontal communication .....	119
Confirmatory Factor Analysis.....	121
Validity and composite reliability .....	127
Common method bias .....	130
Initial hypothesised Structural Equation Model testing the relationship between communication satisfaction on job satisfaction and intention to stay ...	131
Final Structural Equation Model of the effects of communication satisfaction on paediatric nurses' job satisfaction and intention to stay ....	134
Alternative hypothesised structural model .....	136
Alternative final model .....	139
Comparison of models.....	141
Effects of final model .....	143
Job satisfaction SEM .....	143
Post hoc interaction model analysis.....	144
Interaction model for the moderator variable years in position, on horizontal communication and job satisfaction.....	145
Interaction model for the moderator variable age, on horizontal communication and job satisfaction.....	146
Interaction model for the moderator variable job position, on horizontal communication and job satisfaction.....	147
Hypothesis testing.....	148
Summary.....	149

## **CHAPTER 6: DISCUSSION, IMPLICATIONS AND CONCLUSIONS ..... 150**

Introduction.....	150
Overview of organisational communication and job satisfaction and paediatric nurses' intention to leave their job and the nursing profession and looking for another job .....	151
Discussion of the final theoretical model testing the relationship between communication satisfaction on job satisfaction and intention to stay .....	154
Direct determinants of job satisfaction .....	155
Supervisor relationships.....	155
Media quality .....	156
Communication climate.....	157
Indirect determinants of intention to leave and looking for another job....	157

Supervisor relationships.....	157
Media quality .....	158
Communication climate.....	158
Non-significant determinants of job satisfaction, intention to leave and looking for another job.....	158
Demographics .....	158
Horizontal communication .....	159
Corporate perspective .....	159
Organisational integration .....	160
Job satisfaction, intention to leave and looking for another job.....	160
Interaction model analysis .....	161
Generalisability of study findings.....	162
Study demographics.....	162
Position .....	162
Gender and age .....	162
Highest level of education .....	163
Employment status.....	163
Ward area.....	163
Years in the position .....	164
Implications for use of the study findings .....	164
Nursing education .....	164
Nursing leadership .....	165
Future research.....	166
Study limitations.....	168
Sample bias .....	168
One study site.....	169
Low response rate .....	169
Common method variance .....	170
Psychometric properties of study instruments .....	170
Generalisability of study findings.....	170
Knowledge transfer plans .....	171
Candidate reflection.....	172
Summary.....	172

<b>REFERENCES.....</b>	<b>174</b>
<b>APPENDIX A: HISTOGRAMS SHOWING DISTRIBUTION AND NORMALITY .....</b>	<b>189</b>
<b>APPENDIX B: INFORMATION SHEET .....</b>	<b>216</b>
<b>APPENDIX C: QUESTIONNAIRE.....</b>	<b>219</b>

---

# LIST OF TABLES

Table 1: Definition of terms .....	7
Table 2: Summary of search terms .....	19
Table 3: Summary of data extracted from included quantitative studies .....	22
Table 4: Adapted quality assessment used for included quantitative studies .....	34
Table 5: Joanna Briggs Institute appraisal checklist for qualitative research .....	35
Table 6: Qualitative article summary .....	36
Table 7: Number of indicators for latent variables-non-parcelled .....	57
Table 8: Goodness of fit indices used for the SEM .....	66
Table 9: Before group and after group distribution of responses .....	70
Table 10: ANOVA results for before and after groups for the organisational communication satisfaction survey .....	71
Table 11: Summary of participant position .....	72
Table 13: Participant demographics .....	73
Table 14: Mean and median communication satisfaction values for each educational level .....	78
Table 15: Mean and median communication satisfaction between paediatric nurses and middle managers with different years of nursing and managerial experience .....	80
Table 16: Mean and median communication satisfaction between paediatric nurses and middle managers with different contract hours .....	81
Table 17: Mean and median communication satisfaction between paediatric nurses and middle managers from different specialty areas .....	82
Table 18: Mean and median communication satisfaction between male and female paediatric nurses and middle managers .....	84
Table 19: Mean and median communication satisfaction between paediatric nurses and middle managers with different ages .....	84
Table 20: Do you plan to leave your present nursing job? .....	93
Table 21: Are you actively looking for another position in nursing? .....	94
Table 22: If you are/were looking for another job how easy or difficult do you think it would be for you to find an acceptable job in nursing? .....	94
Table 23: Internal consistency reliability .....	95

Table 24: Correlation among study variables .....	97
Table 25: Study variables z scores.....	98
Table 26: Statistically significant differences in response mean to the communication satisfaction questions .....	99
Table 27: Summary of ward nurses’ and managers’ satisfaction with the ‘information about my progress in my job’ .....	100
Table 28: Summary of paediatric nurses’ and managers’ satisfaction with the extent to which my supervisor listens and pays attention to me.....	101
Table 29: Summary of paediatric nurses’ and middle managers’ satisfaction with the ‘extent to which my supervisor offers guidance for solving job related problems’ .....	102
Table 30: Summary of paediatric nurses’ and middle managers’ satisfaction with the ‘extent to which the amount of supervision given to me is about right’ .....	103
Table 31: Summary of paediatric nurses’ and middle managers’ satisfaction with the ‘extent to which people in my organisation have great abilities as communicators’ .....	104
Table 32: Summary of paediatric nurses’ and middle manager’s satisfaction with the ‘extent to which informal communication is accurate and active’	104
Table 33: Summary of paediatric nurses’ and middle managers’ satisfaction with the ‘extent to which the attitudes toward communication are basically healthy’ .....	105
Table 34: Goodness of fit indices used for the SEM.....	108
Table 35: Survey item and labels for organisational integration.....	109
Table 36: Goodness of fit statistics and modification indices for organisational integration .....	111
Table 37: Survey item and labels for corporate perspective.....	111
Table 38: Goodness of fit statistics and modification indices for corporate perspective .....	113
Table 39: Survey item and labels for communication climate .....	113
Table 40: Goodness of fit statistics and modification indices for communication climate .....	115
Table 41: Survey item and labels for supervisor relationships.....	116
Table 42: Goodness of fit statistics and modification indices for supervisor relationships .....	117

Table 43: Survey item and labels for media quality .....	118
Table 44: Goodness of fit statistics and modification indices for media quality	119
Table 45: Survey item and labels for horizontal communication.....	120
Table 46: Goodness of fit statistics and modification indices for horizontal communication.....	121
Table 47: Goodness of fit indices for the initial CFA model .....	123
Table 48: Intercorrelations between composite factors .....	124
Table 49: Goodness of fit indices for the revised CFA model and removal of items .....	126
Table 50: Validity and composite reliability statistics .....	129
Table 51: Total variance explained.....	130
Table 52: Significant statistics for hypothesised SEM.....	134
Table 53: Significance statistics for the alternative SEM.....	139
Table 54: Comparison of final theoretical model and alternative final model ...	141
Table 55: Final model variable's standardised effects (total, direct, indirect) ...	143
Table 56: Significance statistics for job satisfaction .....	144
Table 57: Summary of supported hypotheses.....	148



---

# LIST OF FIGURES

Figure 1: Search and retrieval process .....	20
Figure 2: Organisational communication satisfaction and effect hypothesised conceptual model .....	51
Figure 3: Relationship between paediatric nurses' job satisfaction and intention to leave and looking for another job hypothesised conceptual model .....	51
Figure 4: Interaction effect diagram .....	54
Figure 5: Linearity of relationships between organisational communication satisfaction and job satisfaction .....	64
Figure 6: Communication satisfaction between paediatric nurses and middle managers with different educational levels.....	78
Figure 7: Communication satisfaction between paediatric nurses and middle managers with different years of nursing and managerial experience..	79
Figure 8: Communication satisfaction between paediatric nurses and middle managers with different contracted hours .....	81
Figure 9: Communication satisfaction between paediatric nurses and middle managers from different specialty areas .....	82
Figure 10: Communication satisfaction between male and female paediatric nurses and middle managers .....	83
Figure 11: Communication satisfaction between paediatric nurses and middle managers with different ages .....	84
Figure 12: Summary of paediatric nurses' response to 'The physical condition in which you work' .....	85
Figure 13: Summary of paediatric nurses' response to 'Freedom to choose your own working methods' .....	86
Figure 14: Summary of paediatric nurses' response to 'Your fellow workers' ...	86
Figure 15: Summary of paediatric nurses' response to 'The recognition you get for your good work' .....	87
Figure 16: Summary of paediatric nurses' response to 'Your immediate manager' .....	87
Figure 17: Summary of paediatric nurses' response to 'The amount of responsibility you are given' .....	88
Figure 18: Summary of paediatric nurses' response to 'The rate of pay for nurses' .....	88

Figure 19: Summary of paediatric nurses’ response to ‘Opportunity to use your abilities’ .....	89
Figure 20: Summary of paediatric nurses’ response to ‘The relations between management and staff’ .....	89
Figure 21: Summary of paediatric nurses’ response to ‘Future chance of promotion’ .....	90
Figure 22: Summary of paediatric nurses’ response to ‘The way the hospital is managed’ .....	90
Figure 23: Summary of paediatric nurses’ response to ‘The attention paid to their suggestions’ .....	91
Figure 24: Summary of paediatric nurses’ response to ‘Hours of work’ .....	91
Figure 25: Summary of paediatric nurses’ response to ‘The amount of variety in your job’ .....	92
Figure 26: Summary of paediatric nurses’ response to ‘Your security’ .....	92
Figure 27: Initial congeneric model for organisational integration .....	109
Figure 28: Final congeneric model for organisational integration .....	110
Figure 29: Initial congeneric model for corporate perspective.....	112
Figure 30: Final congeneric model for corporate perspective .....	112
Figure 31: Initial congeneric model for communication climate .....	114
Figure 32: Final congeneric model for communication climate.....	115
Figure 33: Initial congeneric model for supervisor relationships.....	116
Figure 34: Final congeneric model for supervisor relationships .....	117
Figure 35: Initial congeneric model for media quality .....	118
Figure 36: Final congeneric model for media quality .....	119
Figure 37: Initial congeneric model for horizontal communication.....	120
Figure 38: Final congeneric model for horizontal communication .....	121
Figure 39: Initial CFA model for organisational communication satisfaction ...	122
Figure 40: Higher order factor analysis for media and communication climate.....	125
Figure 41: Revised CFA model .....	126
Figure 42: Final CFA model.....	127
Figure 43: Initial hypothesised Structural Equation Model of the effects of communication satisfaction on paediatric nurses’ job satisfaction and intention to stay .....	132
Figure 44: Initial hypothesised model with significant and non-significant pathways .....	133

Figure 45: Final Structural Equation Model of the effects of communication satisfaction on paediatric nurses' job satisfaction and intention to stay with standardised path coefficient and deletion of non-significant pathways .....	135
Figure 46: Initial Iterative hypothesised Structural Equation Model of the effects of paediatric nurses' communication satisfaction on job satisfaction and intention to stay.....	137
Figure 47: Alternative significance model with significant and non-significant pathways .....	138
Figure 48: Final alternative Structural Equation Model of the effects of communication satisfaction on paediatric nurses' job satisfaction and intention to stay with standardised path coefficient and deletion of non-significant pathways.....	140
Figure 49: Final Structural Equation Model for paediatric nurses' communication satisfaction and the effect on job satisfaction and intention to stay.....	142
Figure 50: Initial hypothesised SEM for job satisfaction and intention to stay .	144
Figure 51: Moderating effects of years in position on horizontal communication and job satisfaction .....	146
Figure 52: Moderating effects of age on horizontal communication and job satisfaction .....	147
Figure 53: Moderating effects of job position on organisational integration and job satisfaction .....	148

---

# CHAPTER 1: INTRODUCTION

## INTRODUCTION

The research reported in this thesis focused on paediatric nurses' and middle managers' satisfaction with organisational communication and the effect this had on paediatric nurses' job satisfaction and intention to stay in their current position in a tertiary paediatric hospital in Western Australia. This chapter will outline the background literature pertinent to the topic and state the significance, purpose, aims, research questions, hypotheses and objectives of the study. A brief summary of the methodology will also be provided and an overview of the thesis will be presented for the reader chapter by chapter.

## BACKGROUND

Nursing shortages have been well documented both nationally and internationally over the last two decades (Buchan & Aiken, 2008; Cai, Zhou, Yeh, & Hu, 2011; Hegney, McCarthy, Rogers-Clark, & Gorman, 2002; Hickey, Sumsion, & Harrison, 2010; International Council of Nurses, 2006). However, since the global financial crisis of 2007-2008, a reduction in the exit rates of registered and enrolled nurses from the nursing profession in Australia, United States of America and United Kingdom has been noted. One hypothesis is the negative impact the global financial crisis has had on the superannuation savings of nurses and therefore on their retirement from the workforce (O'Loughlin, Humpel, & Kendig, 2010). Nevertheless, despite this reduction in exit rates, Australia still needs a predicted 85,357 registered and enrolled nurses by 2025 (Health Workforce Australia, 2014); presently there are 360,008 registered nurses, enrolled nurses and midwives registered in Australia, of which 92% are in the nursing and midwifery workforce (Australian Government, 2016). In the thesis and the study reported herein, the term 'nurse' refers to registered (RN) and enrolled nurses (EN).

Nurse shortages lead to an increase in adverse patient outcomes as a result of lower nurse to patient ratios (Buchan & Aiken, 2008; Duffield & O'Brien-Pallas, 2003), an increase in nurse job dissatisfaction and burnout, and difficulties with retention and recruitment (Hegney, Plank, & Parker, 2006; Van Den Tooren & De Jonge, 2008). If retention of nurses can be improved and exit rates maintained at 4.2%, the number of

nurses needed by 2025 will reduce to 39,094 (Health Workforce Australia, 2014). In a nurse shortage situation, one way to improve job satisfaction and work commitment of the existing nursing workforce and thereby help nurse retention is through effective organisational communication (Amos, Hu, & Henrick, 2005; Brooks, 2002). Effective organisational communication links an organisation to its environment and its parts and is essential when developing organisational values, norms and expectations (Gibson, Ivancevich, Donnelly, & Konopaske, 2009).

Effective organisational communication relies on management's ability to receive, transmit and act on information presented to them (Gibson et al., 2009). More specifically, it is middle managers' responsibility to effectively communicate with upper management, peers and subordinates, and to maintain communication flow within an organisation (Diamond, 2011). However, poor communication results in poor performance and quality of care (Awad et al., 2005; Harber & Ashkanasy, 1998), poor collaboration and teamwork, and poor commitment from leaders (Robertson-Malt & Chapman, 2008).

There is a documented connection between job satisfaction, work commitment and organisational communication (Amos et al., 2005; Brooks, 2002; Keyton, 2005). However, paediatric nurses' and middle managers' satisfaction with organisational communication has not been studied in-depth in recent years and specifically, there is a paucity of evidence in relation to paediatric nurses' job satisfaction and intention to stay in their current job.

## **SIGNIFICANCE AND PURPOSE**

As outlined above, it is known that poor communication results in poor performance and quality of care (Awad et al., 2005; Harber & Ashkanasy, 1998), poor collaboration and teamwork, and poor commitment from leaders (Robertson-Malt & Chapman, 2008). These factors can result in lower job satisfaction among nurses and reduced intention to stay in their current job and in the nursing profession (Batch, 2012; Davidson, Folcarelli, Crawford, Duprat, & Clifford, 1997). Likewise, the literature highlights that nursing shortages lead to a decrease in the quality of care provided, resulting in an increase in adverse patient outcomes as well as burnout and job dissatisfaction for remaining nurses, causing difficulties in staff retention (Hegney, Eley, Plank, Buikstra, & Parker, 2006; Morrison, Beckmann, Durie, Carless, & Gillies, 2001; Van Den Tooren & De Jonge, 2008). Whilst there is a documented connection

between organisational communication, job satisfaction and nurses' intention to stay in their current job, paediatric nurses' and middle managers' satisfaction with organisational communication has not been studied in the last decade. It is important to explore satisfaction in the paediatric setting as paediatric nurses have been noted to have above average levels of occupational stress (Mohammad Mosadeghrad, 2014). High levels of occupational stress have been associated with poor health and increased turnover intention, thereby fuelling the nursing shortage (Mohammad Mosadeghrad, 2014). Therefore, the purpose of the study was to investigate middle managers and paediatric nurses' satisfaction with organisational communication and the effect this has on paediatric nurses' job satisfaction and intention to stay in their current job.

It was of significance to investigate organisational communication satisfaction and its effect on paediatric nurses' job satisfaction and intention to stay, due to the lack of literature surrounding paediatric nurses satisfaction with organisational communication and its impact on their intention to stay in their current job. This has allowed bridging of the gap in the current literature and identification of areas and strategies that may aid paediatric nursing retention. The focus of research on organisational communication satisfaction of middle managers and paediatric nurses is necessary to enable effective performance, quality of care, collaboration and teamwork, job satisfaction and intention to stay.

This study has brought to light factors that enhance, and hinder organisational communication satisfaction, and in doing so has allowed for recommendations to be made that may improve organisational communication. In turn, it is anticipated that improved job satisfaction-aiding paediatric nursing retention strategies will ensue. Improved organisational communication, job satisfaction and intention to stay is expected to result in greater performance and quality of care, greater collaboration and teamwork, improved commitment from leaders, increased job satisfaction and improved retention of paediatric nurses. These improvements could reasonably be expected to benefit patients, their families, health care providers, the health agency, nursing scholarship and the wider community.

## **AIMS**

The first aim of this study was to investigate paediatric nurses' and middle managers' satisfaction with organisational communication and the effect this has on paediatric nurses' job satisfaction and intention to stay in their current job. The second

was to assess if there is a difference in organisational communication satisfaction between paediatric nurses and middle managers, different educational experience, years of nursing and managerial experience, contracted hours, area of work, age and gender.

## **RESEARCH QUESTIONS**

As part of this exploration, the study addressed the following broad questions:

1. How satisfied are paediatric nurses and middle managers with organisational communication?
2. What effect does satisfaction with organisational communication have on paediatric nurses' job satisfaction and intention to stay in their current job?
3. What is the relationship between job satisfaction, intention to leave and looking for another job?

## **HYPOTHESES TESTING**

A hypothesis can be either non-directional or directional in nature. A non-directional hypothesis does not predict a direction of the outcome instead states a relationship based on inequality. A directional hypothesis predicts the direction of the outcome rather than predicating inequality only. This is usually used when the outcome is anticipated and supported by the literature. Terms such as positively and negatively, better than and less than are used (Sproll, 2002). In a positive or a direct relationship, as one variable increases, the other increases, and as one variable decreases the other variable decreases. In contrast, in a negative or inverse relationship, the two variables move in opposite directions i.e. As one variable increases the other variable decreases (Le Roy, 2013). The hypotheses will be tested in accordance with the aims of the study and are presented in Chapter 3.

## **ANTICIPATED OUTCOMES**

The specific outcomes expected for this research study at its outset included the discovery of new knowledge about:

- Paediatric nurses' and middle managers' satisfaction with organisational communication and its effectiveness;
- Whether there is a disconnect between paediatric nurses' and middle managers' organisational communication satisfaction;

- Specific organisational communication issues experienced by paediatric nurses and middle managers;
- Paediatric nurses' job satisfaction;
- Paediatric nurses' intention to stay in their current job;
- The relationship between paediatric nurses' organisational communication satisfaction, job satisfaction and intention to stay in their current job; and
- Ways to improve organisational communication, paediatric nurses' job satisfaction and intention to stay in their current job.

## **METHODOLOGY OVERVIEW**

The study employed a cross-sectional quantitative research approach whereby a series of surveys were distributed to paediatric nurses. The surveys have been previously validated and reliability-tested in nursing.

## **THESIS OVERVIEW**

The study reported in this thesis was developed around a series of surveys distributed to paediatric nurses and middle managers, culminating in a response to the research questions. In this first chapter, an outline of the background literature pertinent to the topic was provided along with the significance, purpose, aims, research questions and objectives of the study. This chapter also overviewed the research methodology and the thesis chapter by chapter. Chapter 2 will systematically examine the literature surrounding paediatric nurses' and middle managers' experience of organisational communication and its effect on job satisfaction and intention to stay. The chapter will also examine the facilitators of effective communication, paediatric nurses' and managers' perceptions of organisational communication, and the relationship between job satisfaction and intention to stay. The following organisational concepts and theories will be discussed as a background to the systematic review; organisational structures, communication, communication in nursing and organisational communication.

The methods and materials used within the study design are examined in Chapter 3. A quantitative research approach will be discussed in the chapter, along with theoretical model, relevant instrumentation and sampling, data collection and analysis techniques.



Chapter 4 will present the contextual and demographic findings from the study. Including response bias testing, data preparation and screening, descriptive analysis and Mann-Whitney U Test results.

The Structural Equation Modelling (SEM) results are presented in Chapter 5. Data was first analysed using congeneric and Confirmatory Factor Analysis to measure the relationships between items and a common construct. In this chapter, the relationships between paediatric nurses' organisational communication satisfaction and the effect this has on job satisfaction and intention to stay will be identified. The data analysis will also identify the relationship between job satisfaction and intention to leave and look for another job.

The findings identified will be discussed in Chapter 6 in relation to existing literature and research findings. Along with an overview of the study, the recommendations that emerged from it for nursing practice, nursing management, education and future research and its limitations are also discussed. The thesis will then conclude.

## **DEFINITIONS OF TERMS**

The following definition of terms are used within the context of the study. See Table 1.

**Table 1: Definition of terms**

<b>Term</b>	<b>Definition</b>
Organisation	An organisation is any coordinated unit that consists of two or more people whose function is to achieve a common goal or set of goals (Gibson et al., 2009).
Communication	Communication is derived from the Latin word <i>communis</i> , meaning “common”. In communication, the communicator seeks to establish “commonness” with the receiver. Therefore, communication is defined as the transmission of information and understanding through verbal and non-verbal symbols (Gibson et al., 2009).
Organisational communication	Organisational communication is the process that links an organisation to its environment and its parts (Gibson et al., 2009) and is essential when developing organisational values, norms and expectations (Harber & Ashkanasy, 1998).
Communication satisfaction	The level of satisfaction an employee has between the overall communication flow and variables within the organisation (Kandlousi, Ali, & Abdollahi, 2010).
Communication climate	Communication climate reflects communication on both the organisational and personal levels. It includes both the extent to which communication motivates and stimulates workers to meet organisational goals, and the extent to which it makes them identify with the organisation. Also, it includes whether or not people’s attitudes towards communication are healthy within the organisation (Clampitt & Downs, 1993).
Organisational integration	Organisational integration reflects the degree to which an individual receives information about their immediate environment, and includes information about job progress, personnel news, benefits and pay, and policies and goals (Downs & Hazen, 1977).
Corporate perspective	Corporate perspective reflects the broad elements of the organisation in terms of notifications about changes, information about financial standing, and information about policies and goals (Clampitt & Downs, 1993).
Media quality	Media quality refers to the extent to which meetings are well-organised, written directives are short and clear, and the degree to which the amount of communication is about right (Clampitt & Downs, 1993).
Job satisfaction	Job satisfaction is defined as an affective orientation or overall positive feeling towards one’s work (Coomber & Barriball, 2007; Price, 2001) and is a key factor in nursing retention (Jasper, 2007). There are several predictors which include, stress, organisational trust, communication, autonomy, recognition and leadership behaviours (Laschinger & Finegan, 2005; Moore & Hutchison, 2007).
Intention to stay	Intention to stay refers to the probability of continued membership in an organisation (Cowden, Cummings, & Profetto-McGrath, 2011; Price & Mueller, 1981) and is a good predictor of nursing turnover (Cavanagh & Coffin, 1992; Price & Mueller, 1981; Van Breukelen, Van der Vlist, & Steensma, 2004).

## **SUMMARY**

In summary, effective communication in nursing and healthcare has been linked to high quality patient care, patient satisfaction, collaborative teamwork and commitment from leaders to provide resources (Pearson, 1985; Robertson-Malt & Chapman, 2008). This ultimately results in greater job satisfaction and intention to stay among nurses (Batch, 2012; Davidson et al., 1997).

Whilst there is a documented intrinsic connection between job satisfaction, work commitment and communication (Amos et al., 2005; Brooks, 2002) there is currently no reported research exploring paediatric nurses' and middle managers' satisfaction with organisational communication and the effect this has on job satisfaction and intention to stay. Therefore, the aim of this study was to identify the impact that communication satisfaction has on paediatric nurses' job satisfaction and intention to stay in their current job. In doing so, it is hoped that this study has filled the current gap in the literature and that recommendations can be made to the study site that will assist in nursing retention strategies. Chapter 2 systematically examines the literature surrounding paediatric nurses' and middle managers' experience of organisational communication and the effect this has on job satisfaction and intention to stay.

---

# **CHAPTER 2: LITERATURE REVIEW**

## **INTRODUCTION**

In this chapter the existing body of knowledge on the topic of interest, produced by researchers, academics and practitioners, is systematically identified, evaluated and synthesised (Fink, 2010). It is known that effective communication in nursing and healthcare results in high quality patient care, patient satisfaction, collaborative teamwork and commitment from leaders (McCaffrey et al., 2011; Pearson, 1985; Robertson-Malt & Chapman, 2008) which, ultimately results in greater job satisfaction and intention to stay in their current job (Batch, 2012; Davidson et al., 1997). There is a documented connection between job satisfaction, work commitment and effective organisational communication (Amos et al., 2005; Brooks, 2002). Therefore, the purpose of this chapter is to systematically examine the literature surrounding paediatric nurses' and middle managers' satisfaction with organisational communication and the effect this has on paediatric nurses' job satisfaction and intention to stay in their current job. The chapter will begin with a review of the broader organisational theory and communication literature to provide a context for the current study. Following this, the systematic review process will be discussed in relation to the review questions, search strategy, inclusion and exclusion criteria, data extraction, synthesis and review findings.

## **ORGANISATIONAL STRUCTURES**

An organisation is a social arrangement of people and resources working together in a consciously designed, coordinated and controlled structure to achieve a common goal or objective (Burton, DeSanctis, & Obel, 2006; Gibson et al., 2009; Jones, 2004; Martin, 2005). An organisation uses information in order to coordinate and control its activities. By processing information, the organisation can observe, analyse problems and communicate with others (Burton et al., 2006). Therefore, an organisation needs to be designed to effectively and efficiently process information.

The design of an organisation results from the decisions and actions made by management and results in specific organisational structures. These decisions and actions are made regarding how to divide the tasks of the organisation into smaller sets of activities in terms of job specialisation, how to group the individual jobs (Burton et

al., 2006; Gibson et al., 2009), the appropriate size of each group responding to a superior, and the distribution of authority among the jobs (Gibson et al., 2009).

Of these four aspects, the distribution of authority, or the 'shape' of the organisation, is perhaps most important as it determines how efficiently an organisation's decision making and communication systems work. A tall organisation is one that is defined as having many levels within the hierarchy in relation to the organisation's size (Jones, 2004). In contrast, an organisation that has fewer levels within the hierarchy is considered to be flat (Mckee, Kemp, & Spence, 2012). According to Jones (2004), organisations that have too many levels within the hierarchal structure suffer from communication inadequacies. As the chain of command lengthens so does the time it takes for communication between the bottom and the top, which ultimately results in slower organisational performance. Another communication issue is the level of distortion that can be identified in information travelling up and down the hierarchy through many levels of management. Additionally, managers can also manipulate the information that is communicated by restricting the flow of information (Jones, 2004). Therefore, an organisation's structure will not only vary depending on the choices that management have made regarding the design, but will also impact on the efficiency of communication systems within the organisation. An organisation can be classed as either a mechanistic or an organic structure (Gibson et al., 2009).

### **Mechanistic structure**

A mechanistic or bureaucratic structure is designed to encourage individuals within an organisation to behave in an expected way with centralised decision making (Jones, 2004), routine job functions (Mckee et al., 2012) and close supervision of subordinates. Information in this type of structure flows vertically down through the many levels of the hierarchical structure and tends to be distorted and inaccurate (Gibson et al., 2009). Each functional level of the hierarchical structure is separate, and communication and cooperation among the levels are the responsibility of someone at the top of the structure. Mechanistic structures function with formal written rules and procedures that specify roles, responsibilities and standardisation (Jones, 2004). Communication in a mechanistic structure tends to flow downward and tends to be distorted, inaccurate and viewed with suspicion by subordinates (Gibson et al., 2009).

Promotion up the hierarchical structure is slow, and is dependent on individual performance (Jones, 2004).

### **Organic structure**

Organic structures are at the opposite end of the scale to mechanistic structures and promote flexibility, allowing people to initiate change and adapt to unpredictable and turbulent environments (Jones, 2004). The hierarchy is flattened to reduce the levels of supervision, and the decision making is decentralised (Jones, 2004; Luthans, 2011; Mckee et al., 2012) with decisions being made as the organisation dictates. Informal values and norms are developed on the basis of individual expertise, competence and abilities (Jones, 2004). Other characteristics of an organic structure are; distributed network of control and authority, task flexibility, knowledge sharing and teamwork (Cosh, Fu, & Hughes, 2012). Communication in an organic structure allows information to move freely through the organisation upward, downward and laterally with the majority of communication being lateral rather than vertical in direction (Cosh et al., 2012; Gibson et al., 2009). However, due to the multifarious nature of healthcare provisions, it seems that healthcare organisations need a unique approach that includes both organic and mechanistic approaches (Olden, 2012).

### **Healthcare structures and design**

The complexity of providing healthcare services presents different challenges in structuring for effectiveness than in many other service industries (Duffield, Kearin, Johnston, & Leonard, 2007). Traditionally, healthcare institutions are shaped by the bureaucratic or mechanistic model, characterised by authoritarian hierarchy and control (Lluch, 2011; Penprase & Norris, 2004; Uhl-Bien, Marion, & McKelvey, 2007), with healthcare leaders relying on the top-down process to achieve maximum efficiency (Kubica, 2008; McAlearney & Butler, 2008). The biggest advantage of bureaucratic control is that it creates a command and control cycle for the business leadership, which makes an organisation more efficient (Jones, 2004). This results in nurses being suppressed by the dominant managerial group (Gibson et al., 2009) and discourages creativity and innovation, which leads to dissatisfaction among employees and high employee turnover rates (Boundless, 2014).

As far back as 1982 it was identified that nursing retention was positively influenced by flat organisational structures, decentralised decision making by bedside

caregivers, inclusion of chief nurse executives in top management decision making, flexible shifts, unit self-governance and investment in continuing nurse education (Muller, 1995). Hospitals with these features have become known as magnet hospitals (Aiken, 2002) and promote healthy work environments, a culture of good communication (Erenstein & McCaffrey, 2007), collaboration, decision making, adequate staffing and efficient leadership (Ulrich et al., 2007). Magnet status is something that hospitals now aspire to all over the world, as such hospitals have been making widespread changes to practice, education and management. One impact of the resulting flattening of the hierarchy is that nurses are now increasingly required to develop their own management and leadership qualities, for which good methods of communication are vital (Tourish & Mulholland, 1997).

## **COMMUNICATION**

Communication is derived from the Latin word *communis*, meaning 'common', and involves the transmission of information and understanding (Gibson et al., 2009) through both verbal and non-verbal symbols (Stein-Parbury, 2008). The ongoing and interactive process of communication seeks to establish 'commonness' with the receiver, whilst also satisfying the physical, identity, social and practical needs of the individual (Adler & Rodman, 1997; Gibson et al., 2009).

The communication process allows individuals to co-orient their behaviours to establish functional and interpersonal relationships allowing goal attainment (Kreps, 1990; Luthans, 2011). This personal and behavioural exchange can be undertaken in four distinct levels; interpersonal (between two or a small group of people), intrapersonal (cognitions and sense making of each individual), network and organisational, and macro societal or mass level (Tourish & Mulholland, 1997). Effective communication at these different levels requires an understanding of the way verbal and non-verbal language is used and is dependent upon self-awareness and empathy towards others understanding of language (Stein-Parbury, 2008). Additionally, knowledge of the process of communication as a means of generating mutually shared meanings is also an important component of effective communicative interactions (O'Toole, 2012; Putnis & Petelin, 1999).

Communication can be undertaken through both formal and informal channels. Formal communication refers to communication that is written and takes place through prescribed networks (Downs & Adrian, 2004), such as electronic media and information

technology (Batch, 2012). It functions through rules and regulations and by more formalised channels of communication that have a record of the communication dispatched. Additionally, formal communication is the result of the rights and duties given by the employers and cannot result in grapevines (Kushal & Ahuja, 2009). In contrast, informal communication is created whenever people meet and interact through social relationships (Kandlousi et al., 2010) and can be spontaneous and unplanned (Downs & Adrian, 2004). In general, there are no rules or regulations followed in this type of communication and as a result grapevines can form (Harber & Ashkanasy, 1998; Kushal & Ahuja, 2009). Grapevines can act as a constant source for rumours and require careful managing in order to prevent disruptions to organisational activities (Gibson et al., 2009). Information received and sent, the timeliness of the information, communication channels used, sources of information, follow up and action taken and the characteristics of communication relationships can all impact on the quality of communication interaction and the information transferred (Sutcliffe, Lewton, & Rosenthal, 2004; Williams et al., 2007).

### **Communication in nursing**

Effective communication is fundamental to nursing practice (Timmins, 2011), and in Australia, effective communication has become a national competency standard that each registered nurse is assessed on as a part of their annual registration renewal (Nursing and Midwifery Board of Australia, 2006). Nurses must communicate effectively using both formal and informal sources in order to provide a variety of strategies and interventions. These strategies and interventions include the use of communication technologies, communicating within a multidisciplinary team, providing patient reports both throughout and at shift change in oral and written formats, including observations and medications, providing families with patient information and offering support (Timmins, 2011). Studies have found that nurses do have good communication skills, however organisational culture and workplace policies create barriers to effective communication (Chant, Jenkinson, Randle, & Russell, 2002; Edwards, Peterson, & Davies, 2006; McCabe, 2004). Whilst there are numerous studies exploring communication in nursing, there is no literature specifically exploring organisational communication satisfaction for nurses in the Australian paediatric setting.



## **Organisational communication**

The communication process links an organisation to its environment and its parts (Gibson et al., 2009) and is essential when developing organisational values, norms and expectations (Harber & Ashkanasy, 1998). Effective organisational communication is dependent upon structure, superior-subordinate relations, socialisation, culture, commitment (Welch, 2006) as well as relevant, timely and accurate information transfer (Bryne & LeMay, 2006; Schneider, Donaghy, & Newman, 1975). Organisations with good internal communication systems experience greater productivity, greater innovation, reduced absenteeism and fewer strikes (Clampitt & Downs, 1993; Tourish & Mulholland, 1997).

### *Directions of organisational communication in a hierarchical structure*

Communication within an organisation should be provided in four distinct ways: upward, downward, horizontal and diagonal. Upward communication flows from individuals in lower levels in an organisation to those in higher levels. Communication in this type of direction includes the use of suggestion boxes, grievances and group meetings. In larger organisations it is especially difficult to get open, honest information from employees to management (Gibson et al., 2009), and many are dissatisfied with upward communication strategies (Bartels, Peters, de Jong, Pruyn, & van der Molen, 2010).

Downward, or top-down, communication flows from individuals in higher levels within the hierarchy to those in lower levels and can include instructions, memos, policy statements, procedures and manuals (Gibson et al., 2009). A major criticism in large organisations, such as hospitals, is that all communication flows downwards from administrators through each managerial level. Distortion can occur at each of these different managerial levels as individuals try to understand, comprehend, relate, communicate, visualise and interpret the message (Schneider et al., 1975). This distortion results in inadequate and inaccurate communication which leads to staff stress (Gibson et al., 2009), and results in nurses being less likely to want to remain employed (Tourangeau & Cranley, 2006). Effective upward and downward communications have been identified as strong predictors of organisational commitment (Postmes, Tanis, & De Wit, 2001).

Horizontal communication refers to communication with individuals on the same hierarchical level (Bartels et al., 2010) and involves peer-to-peer interactions (Gibson et

al., 2009). This type of communication is usually used for task-related and informal communication (Postmes, 2003) and is essential for coordinating and integrating diverse organisational functions (Gibson et al., 2009). Effective horizontal communication has also been linked to an individual's professional identification (Bartels et al., 2010). Diagonal communication refers to communication between managers and employees in different communication divisions (Baker, 2002; Wilson, 1992). This type of communication is effective when members cannot communicate effectively through other channels and is efficient in terms of time and organisational effort (Gibson et al., 2009).

### **Organisational communication in the healthcare setting**

Organisational communication in healthcare can be undertaken through both formal and informal channels (Kushal & Ahuja, 2009), including electronic media and information technology, interpersonal communication and non-verbal communication (Luthans, 2011). In healthcare, communication takes on the form of speaking, listening, reading and writing (Batch, 2012). It is the use of these informal and formal channels of communication that fosters shared perceptions of goals, behaviours and tasks to be communicated among employees (Ostroff, Kinicki, & Tamkins, 2003; Veld, Paauwe, & Boselie, 2010).

Effective communication within an organisation relies on the ability of members to identify and resolve workplace issues, reflect on foundations that guide sense making and develop a culture that balances both individual and organisational goals (Lindlof & Taylor, 2002). In nursing effective, open and clear communication has become an essential tool linking efficient practice to high quality patient care (Robertson-Malt & Chapman, 2008) as it allows nurses' suggestions to be heard, valued and accepted, and practices to be changed at the bedside (Robertson-Malt & Chapman, 2008). Hutton (1994), explains that individuals feel happier and do a better job when what is required of them has been clearly communicated. Both Brooks (2002), and Amos, Hu and Henrick (2005), highlight the intrinsic connection between job satisfaction, work commitment and communication. Likewise, a close correlation between good communication, quality of care, patient outcomes and job satisfaction has been noted (Chu, Hsu, Price, & Lee, 2003). Nurses that receive positive and effective communication in their workplace display increased work satisfaction, work commitment and feel they provide a greater quality of care (Batch, 2012; Davidson et

al., 1997). This leads to benefits such as improved productivity, greater motivation and innovation, reduced absences and grievances (Bryne & LeMay, 2006; Clampitt & Downs, 1993; Tourish & Mulholland, 1997), and assists in building relationships between workers, management and the external environment (Batch, 2012).

In contrast, without effective communication, high quality patient care, patient satisfaction, collaboration and teamwork and commitment from leaders to provide resources, becomes lost (Pearson, 1985; Robertson-Malt & Chapman, 2008). Unfortunately, healthcare systems suffer from enormous inadequacies related to poor communication (Coiera & Tombs, 1998), with an estimated \$12 billion economic waste arising from poor communications in hospitals across the United States of America (Aiken, Clarke, & Sloane, 2002; Ritu Agarwal, Sands, & Jorge Díaz Schneider BS, 2010). Healthcare staff have consistently rated communication as an important factor that contributes to a good workplace, and as one of the factors most in need of improvement (Horsley, 1996; Tourish & Mulholland, 1997). Information accessibility, hierarchical filtration, and ease of access are felt by both managers and staff to be important aspects of organisational communication, but the process to locate information can be long and exhaustive (Yazici, 2002). This leads to frustration and inefficient work environments (Yazici, 2002). Poor communication has been linked to poor performance, increased absenteeism, and increased employee turnover (Gray & Laidlaw, 2004; Robertson-Malt & Chapman, 2008).

In Australia, nurses have been found to be dissatisfied with organisational relationships and outcomes, the amount of information being received, and the length of time for communications to take place (Braff, Manias, Finch, Riley, & Munro, 2012). Additionally, a study conducted at the Princess Alexandra Hospital in the Queensland healthcare system, identified a lack of vision, values and direction, lack of or ineffective meetings, lack of consultation and feedback, lack of senior/middle management visibility, need for more face-to-face communication, lack of resources including staff, equipment and information, need for improvement in both top-down and bottom-up communication and unclear reporting lines contributed to communication difficulties (Horsley, 1996). Nurses who are dissatisfied with their jobs are more likely to not stay, both in the organisation they are dissatisfied with and in the profession of nursing itself (Abualrub & Alghamdi, 2012), which consequently results in nursing retention difficulties (Hazell, 2010; Mosadeghrad & Ferdosi, 2013; Ramoo, Abdullah, & Piaw, 2013; Wang, Tao, Ellenbecker, & Liu, 2012). Therefore, effective communication

within healthcare settings should be a core management concern, as it allows an organisation to become more cohesive, and enhances its ability to achieve its objectives and goals (Tourish & Mulholland, 1997).

## **SYSTEMATIC REVIEW**

The following section will present the results from the systematic review.

### **AIM**

The aim of this review is to examine the impact of organisational communication on nurses' job satisfaction and paediatric nurses' intention to stay in their current job. In addition, this review examines facilitators of effective organisational communication, the differences between paediatric nurses' and middle managers' experience with organisational communication and the relationship between job satisfaction and intention to stay. An objective of this review is to make recommendations for further research.

### **REVIEW QUESTION DEVELOPMENT**

In order to identify, evaluate and synthesise available literature a review question was established. By using a review question along with inclusion and exclusion criteria, the potential for bias is reduced and the focus cannot be changed once the review results have been reviewed (Averis & Pearson, 2003). To establish a good review question, the mnemonic PICOS was utilised for the quantitative research studies. PICOS stands for population, intervention, comparison intervention, outcome measures and study design. For review of qualitative research, the mnemonic PICo was utilised. The core elements of PICo include population, phenomenon of interest and context.

### **PICOS statement**

The following PICOS statement was used for quantitative studies.

Population: paediatric nurses and middle managers working in acute care hospital wards.

Intervention: effective communication.

Comparator: ineffective communication.

Outcome: the nursing outcomes job satisfaction and intention to stay.

Study design: Observational and descriptive studies including cross-sectional, prospective cohort studies and case-control studies. Experimental studies including experimental and quasi-experimental studies and studies using qualitative designs. Also included were mixed method studies where both quantitative and qualitative components are utilised together by a researcher.

#### *PICo statement*

The following PICo statement was established for review of qualitative studies.

Population: paediatric nurses and middle managers.

Phenomena of interest: nurses' and middle manager's satisfaction with hospital communication, job satisfaction and intention to stay.

Context: multi-day acute care hospital wards.

#### *Research review questions*

The following review questions were established based on the aims and outcomes of the study.

1. What is the impact of effective organisational communication compared to ineffective organisational communication on paediatric nurses' job satisfaction and intention to stay?
2. What facilitates effective communication within a hospital?
3. Do paediatric nurses and managers experience organisational communication differently within a healthcare organisation?
4. What is the relationship between paediatric nurses' job satisfaction and intention to stay?

## **DESIGN AND SEARCH METHODS**

The general conventions outlined by the Joanna Briggs institute for systematic reviews were followed for this systematic review (Aromataris & Pearson, 2014). The search strategy included five electronic databases CINAHL Plus with full text, Scopus, MEDLINE, PsycINFO and SPORTDiscus with full text data bases. A search of English-language literature in journal articles published between 1980 and 2017 was conducted using the keywords and phrases, presented in Table 2, together with the

Boolean Operators ‘AND’ and ‘OR’ to combine population, intervention, comparison intervention and outcome measure keywords.

*Table 2: Summary of search terms*

<b>Population</b>	<b>Intervention</b>	<b>Comparison Intervention</b>	<b>Outcome Measures</b>
Paediatric nurses Nurses Middle managers Nurse administrators Healthcare Hospitals Leadership Magnet Non-magnet	Effective communication, Facilitators of effective communication, Horizontal communication, Diagonal communication, Downward communication, Upward communication, Subordinate relationships Organisational/organizational communication, Managerial communication, Administrative communication, Nurse-manager communication, Organisational/organizational culture, Intra-organizational communication	Ineffective communication, Poor communication, Communication barriers	Job satisfaction, Intention to stay, Intention to leave, Commitment, Personnel turnover

A manual search of literature was also conducted for English articles published that examine organisational/administrative/managerial communication, job satisfaction and intention to stay/leave. Additional related published research cited in reference lists were also reviewed.

## **INCLUSION AND EXCLUSION CRITERIA**

The following inclusion and exclusion criteria were established for the review. Articles were included if they were peer reviewed, written in English language, explored or measured organisational/administrative/managerial communication in nursing, healthcare organisations or hospitals, studies that examined the relationship

between organisational/administrative/managerial communication and nurses' job satisfaction and intention to stay or leave/commitment/turnover. Both qualitative and quantitative studies were included in the search as well as unpublished research to minimise the risks of publication bias (Averis & Pearson, 2003). Excluded from the study were articles discussing community, long term care, nursing homes, interdisciplinary communication and articles written in languages other than English. Literature reviews and systematic reviews were also excluded as these are not original research articles (Brain, 2010).

## SCREENING

Each abstract was reviewed twice for inclusion. Studies were excluded if they did not measure organisational/administrative/managerial communication in healthcare, hospitals or nursing or did not measure the relationship between organisational/administrative/managerial communication and nurses' job satisfaction and intention to stay or leave. See Figure 1 for the search and retrieval process.

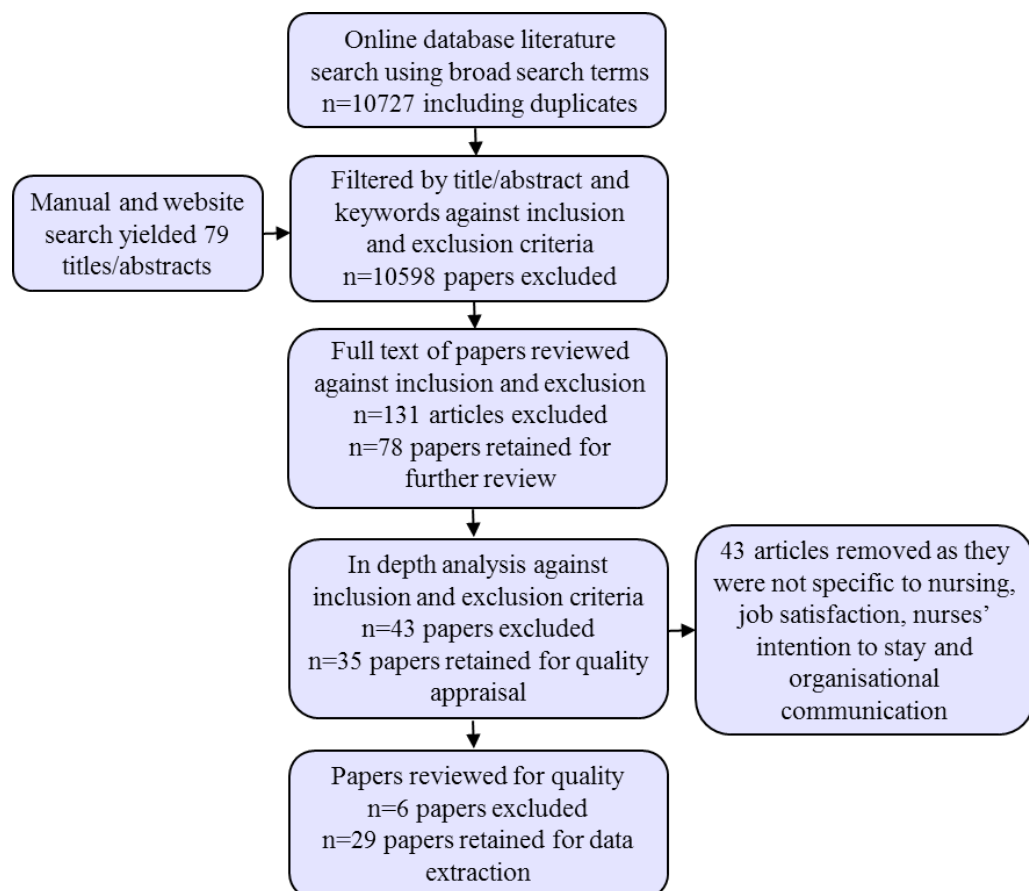

*Figure 1: Search and retrieval process*

## **DATA EXTRACTION AND QUALITY APPRAISAL**

The following data were extracted from the included quantitative studies: author, journal, country, date of publication, research purpose or objective, theoretical model, design setting, sampling method, measurement instruments, reliability and validity, significant and non-significant findings. Table 3 presents a summary of included quantitative studies.



**Table 3: Summary of data extracted from included quantitative studies**

Author (Year) Journal and Country Study Design	Theoretical Model	Sample/ Sampling Method/ Setting	Measurement /Instruments	Scoring	Reliability (Cronbach's alpha)	Validity	Analysis	Significant Findings
<b>Theme 1 Impact of organisational communication on nurses' job satisfaction and intention to stay in one's job</b>								
Naz & Gul (2014)  Journal of Psychological Research  Pakistan  Study design not reported	None	120 female nurses government and private hospitals in Rawalpindi and Islamabad.	1. Turnover intention scale 2. Organisational commitment scale 3. Communication satisfaction questionnaire	3 items  9 items  40 items	0.85  0.79  0.93	Not reported	1. Pearson Product Moment Correlation 2. Hierarchical regression 3. One way ANOVA	1. Communication satisfaction with co-workers, supervisors, and upper management has a negative relationship with turnover intentions. 2. Organisational commitment has a significant moderating role in the relationship of communication satisfaction and turnover intentions.
Pincus (1986)  Human Communication Research  United States of America  Study design not reported	Researcher developed research model	327 hospital nurses at one hospital. 66% response rate.	1. Communication satisfaction questionnaire 2. Job description index 3. Researcher developed: Job performance questionnaire	45 items  30 items  7 items	.67-.92 median 0.80  0.73-0.84 median 0.80  0.93	Not reported	1. Pearson product- moment correlation 2. Step wise multiple regression 3. Canonical correlation analysis 4. Kendall's Coefficient of concordance	1. Positive relationship between communication satisfaction and job satisfaction, and communication satisfaction and job performance. 2. Supervisor communication, communication climate and personal feedback-were found to be most strongly related to both job satisfaction and performance. 3. Top management communication was substantially related to job satisfaction and, to a lesser degree, job performance.

<b>Author (Year) Journal and Country Study Design</b>	<b>Theoretical Model</b>	<b>Sample/ Sampling Method/ Setting</b>	<b>Measurement /Instruments</b>	<b>Scoring</b>	<b>Reliability (Cronbach's alpha)</b>	<b>Validity</b>	<b>Analysis</b>	<b>Significant Findings</b>
Varona (1996)  Journal of Business Communication  Guatemala  Study design not reported	None	3 Guatemalan organisations 1. Private catholic school = 117 participants 2. Private catholic children hospital = 46 participants 3. Food factory = 117 participants	1. Communication Audit questionnaire 2. Organisational commitment questionnaire. 3. Organisational commitment instrument.	10 items  15 items  9 items	0.97  0.76  0.55	Used validity from previous research	1. Factor analysis 2. Pearson correlations analysis 3. Stepwise multiple regression 4. Paired tests 5. ANOVA	1. Positive relationship between communication satisfaction and employees' organisational commitment. 2. Supervisors were significantly more satisfied than subordinates with overall communication practices. 3. Employees with greater tenure were more committed to the organisation. 4. Organisational integrations, media quality, supervisor communication, organisational perspective, communication climate and horizontal communication were significant predictors of commitment
Kaddourah, Khalidi, Abu-Shaheen & Al- Tannir (2013)  Journal of Clinical Nursing  Lebanon  Cross sectional survey	None	140 participants 78.9% response rate. One hospital.	1. Work Quality Index Scale	38 items	0.94	Factor analysis - construct validity	1. Binomial test 2. Fishers exact test	1. 50% of nurses had inadequate communication with superiors.

Author (Year) Journal and Country Study Design	Theoretical Model	Sample/ Sampling Method/ Setting	Measurement /Instruments	Scoring	Reliability (Cronbach's alpha)	Validity	Analysis	Significant Findings
Spence-Lashinger, Purdy & Almost (2007)  The Journal of Nursing Administration  Canada  Non-experimental predictive design	Kantar's theory of structural empowerment.  Psychological empowerment.  Leader- Member exchange theory.	141 participants retained from a provincial registry.	1. Structural empowerment = conditions of Work Effectiveness Questionnaire - II 2. Psychological empowerment scale 3. LMX-MDM 4. CSE 5. Job satisfaction subsection of the pressure management subscale of the pressure management indicators	19 items  12 items  12 items  12 items	0.62-0.80  0.89-0.93  0.72-0.97  0.56-0.77  0.88	Not reported	1. Descriptive and inferential analysis 2. Structural Equation Modelling	1. 40.4% variance in job satisfaction was explained by leader- member exchange quality, empowerment and core self-evaluation 2. Higher quality relationships with their supervisors were associated with greater manager structural and psychological empowerment and greater job satisfaction.
Frone & Major (1988)  Group and Organisation studies  United States of America  Study design not reported	None	93 nurse managers. 68% response rate. One hospital.	1. Job involvement 2. Job satisfaction = 2 items from the Michigan facet-free job 3. Communication Quality = ICA Aommunication Audit	10 items 2 items  3 items scale	Previous reliability used	Previous validity used	1. Product- moment correlations 2. Hierarchical moderated regression analysis	1. The quality of information received from immediate supervisors, co-workers and subordinates was positively related to job satisfaction among highly job involved nurses but unrelated to job satisfaction among low job involved nurses. 2. The quality of information received from administration was positively related to job satisfaction for both highly and low job involved nurses.

<b>Author (Year) Journal and Country Study Design</b>	<b>Theoretical Model</b>	<b>Sample/ Sampling Method/ Setting</b>	<b>Measurement /Instruments</b>	<b>Scoring</b>	<b>Reliability (Cronbach's alpha)</b>	<b>Validity</b>	<b>Analysis</b>	<b>Significant Findings</b>
Brunetto, Farr-Wharton, and Shacklock (2011)  Contemporary Nurse  Australia  A cross-sectional design	LMX theory	900 useable surveys from nurses working in private hospitals. 20% response rate.	1. Satisfaction of supervisor–subordinate communication relationship, 2. Role Ambiguity in relation to supervisors was operationalised 3. Four item measure of self-determination 4. Four-item commitment instrument	10 items  3 items  4 items  4 items	0.803-0.905	Not reported	1. Factor analysis 2. Correlation matrix 3. Linear regression 4. Path analysis	1. The data showed that approximately a quarter (24.6%) of the variance of nurses' affective commitment can be explained by supervisor communication, supervisor ambiguity and discretionary power. 2. The data showed that 61.4% of the role ambiguity in relation to the supervisor can be explained by the variance of the supervisor–subordinate communication relationship.
Braff, Manias, Finch, Riley & Munro (2012)  Journal of Critical Care Nursing  Australia  Prospective Cross sectional survey design	Conceptual framework – communication model	281 service providers across three Australian public hospitals. 30% response rate.	1. International Communication Association (ICA) survey	135 items	Used previously established	Not reported	1. Descriptive statistics 2. For double scale item a single scale value was calculated subtracting one score from the other (i.e. amount needed from amount received)	1. Respondents were dissatisfied with communication from top management and service providers. 2. Employees employed in an operating room or post anaesthetic care unit perceived communication of information to be inadequate.

Author (Year) Journal and Country Study Design	Theoretical Model	Sample/ Sampling Method/ Setting	Measurement /Instruments	Scoring	Reliability (Cronbach's alpha)	Validity	Analysis	Significant Findings
<b>Theme 2 Facilitators of effective organisational communication</b>								
Upenieks (2002)  Journal of Nursing Administration  United States of America  Mixed method study	None	305 nurses rated their perceptions of job satisfaction.  Across 2 Magnet and 2 Non- magnet hospitals 44% response rate.  16 leaders interviewed.	1. Revised nursing work index (NWI- R) measurement tool	Not reported	Not reported	Not reported	1. Measures of central tendency 2. 2 tailed t-test 3. Content analysis 4. Triangulation analysis was used 5. Matrix system constructed to answer interview questions related to institution survey scores	1. Difference in job satisfaction scores related to greater visibility and responsive nurse leaders, better support of clinical nurses' autonomous decision- marking by magnet nurse leaders, and greater support of professional nursing climate at magnet hospitals as evidenced by adequate staffing.
Wright (2011)  Journal for Healthcare Quarterly  United States of America  Study design not reported	None	221 healthcare workers from 3 large administration hospitals.	1. Communication competence survey 2. Workplace conflict style 3. Global measure of Perceived stress scale 4. Job satisfaction survey 5. Job burnout	36 items  25 items  14 items	0.91  0.73-0.86  0.82  0.95  0.92	Not reported	1. Regression analysis	1. The results indicated that higher communication competence scores were predictive of integrating and obliging conflict styles among healthcare workers 2. Lower communication competence scores were predictive of dominating and avoiding conflict styles. 3. An integrating conflict style was predictive of reduced stress and increased job satisfaction 4. Dominating and avoiding conflict styles were predictive of increased job burnout among the participants.

Author (Year) Journal and Country Study Design	Theoretical Model	Sample/ Sampling Method/ Setting	Measurement /Instruments	Scoring	Reliability (Cronbach's alpha)	Validity	Analysis	Significant Findings
Amos, Hu & Herrick (2005)  Journal for Nurses in Staff Development  United States of America  Pre-post test study design	Conceptual framework used- Homans' social system conceptual model	44 nurses participated out of 52.  84.6% response rate.  One hospital.	1. Staff communication Questionnaire 2. IWS	25 Items  44 Items	0.96  0.91	Previously well validated	1. Paired t-test 2. Long term benefits tested using Continuous Employee Perceptions Survey.	1. Team-building activities improved staff communication and job satisfaction. 2. Team-building strategies assisted the nurse leader/manager to build an effective team by strengthening communication and interpersonal relationships so that the staff could function as a more cohesive group.
Rouse & Al- Maqbali (2014)  Journal of Nursing Management  Oman  Mixed methods	None	1526 nurses. 22 hospitals in Oman.	1. Paper and pen survey collected open ended data	Not mentioned	0.91	Not reported	1. Descriptive and frequency statistics 2. Chi-squared	1. The participants reported frustration with nurse managers who seemed overly focused on mistakes. 2. Many participants felt there was little to no appreciation for tasks that were well done. 3. Nurses also disliked being disciplined openly in front of colleagues or patients. 4. The participants stressed that nurse manager feedback should be shared privately and framed in a positive and constructive tone. 5. Active listening, team collaboration and the avoidance of discrimination/favouritism were also emphasised. 6. A supportive and communicative work environment promotes nurses' dignity and respect. 7. Embarrassing nurses in front of other health care professionals may be counterproductive.

Author (Year) Journal and Country Study Design	Theoretical Model	Sample/ Sampling Method/ Setting	Measurement /Instruments	Scoring	Reliability (Cronbach's alpha)	Validity	Analysis	Significant Findings
Khodadadi, Ebrahimi, Moghaddasian & Babapour (2013)  Journal of Caring Science  Iran  Experimental pre- post study	None	73 nurses. 160 patients who had received care from nurses.  Nurses in hospitals of Tabriz.	1. Communication skills questionnaire of nurses. 2. Job satisfaction questionnaire 3. Quality of nursing care questionnaire 4. Self-efficacy questionnaire of nurses.	29 Items  21 items  46 items  17 items	0.91	Content validity previously conducted on surveys	1. Paired t-test 2. Student's independent t-test	1. Statistically significant difference between control and experimental groups after intervention teaching communication skills. 2. The paired t-test showed a statistically significant difference in the experimental group before and after the intervention. 3. Independent t-test showed a statistically significant difference between the rate of quality of care in patients of control and experimental groups after the intervention
Chang & Chang (2009)  Journal of Advanced Nursing  Taiwan  Cross sectional design	None	318 returned surveys or which 18 discarded due to incomplete answers. 66.7% valid response rate  Nurses at 2 hospitals in Taiwan	1. Modification of Questionnaires previously developed 2. Expert review 3. Pilot study	Not reported	Factor loadings exceeded 0.7	Convergent validity and discriminant validity	1. Descriptive statistical analysis 2. Structural Equation Modelling	1. Internal marketing associated with an increase in organisational commitment. 2. Communication management had greatest influence on organisational commitment.

Author (Year) Journal and Country Study Design	Theoretical Model	Sample/ Sampling Method/ Setting	Measurement /Instruments	Scoring	Reliability (Cronbach's alpha)	Validity	Analysis	Significant Findings
<b>Theme 3 Nurses and managers experience of organisational communication</b>								
Tourish & Mullholland (1997)  Journal of Nursing Management  United Kingdom  Mixed method  Using open ended questions	None	Communication audit. One hospital. Sixty-two respondents completed the questionnaire.	1. Survey adapted from previous validated and extensively used audits.	Not reported	Not reported	Convergent validity	1. Responses were converted into mean scores for each item in the questionnaire by summing the raw scores for all responses. 2. Wilcoxon signed ranks test. 3. Cross tabulations 4. Chi-square tests	1. Significant discrepancy between the amount of information that nurses received and the amount that was needed to do the job successfully. 2. Nurses did not receive adequate information about how well they are doing their job, how they are being judged and how decisions about their jobs are being made. 3. The participants strongly expressed having 'very little or 'little' information received from senior managers, while between 'some' and a 'great deal' of information is actually required. 4. Overall, nurses desired more information through the channels that involve direct contact with their immediate managers and senior managers; becoming more involved with expressing concerns and evaluating general systems and the roles of senior managers above them was also noted to be important.



Author (Year) Journal and Country Study Design	Theoretical Model	Sample/ Sampling Method/ Setting	Measurement /Instruments	Scoring	Reliability (Cronbach's alpha)	Validity	Analysis	Significant Findings
<b>Theme 4 Relationship between job satisfaction and intention to stay in one's job</b>								
Ahmad & Oranye (2010)  Journal of Nursing Management  United Kingdom and Malaysia  Descriptive correlational design	None	556 Participants Hospitals in England and Malaysia.	1. The Structural Empowerment scale. 2. The Psychological Empowerment scale. 3. The Index of Job satisfaction scale. 4. Organisational commitment scale.	4 subscales  12 items  6 component 18 items	Ranged between 0.783 and 0.901	Construct content validity	1. Chi-test statistics 2. Spearman's rho 3. Pearson's correlation	1. Paradoxically, the fact that workers are satisfied with their job does not automatically translate to their commitment to the organisation. 2. A significant correlation between job satisfaction and total organisational commitment was noted at a P- value = 0.01 for both countries.
Gurková, Soósová, Haroková, Žiaková, Šerfelová & Zamboriová (2013)  International Nursing Review  Slovak and Czech Republic  Cross sectional descriptive survey	None	1055 hospital nurse from 12 hospital in the Czech and Slovak republics. Total response rate of 87.9%	1. Domains of job satisfaction were operationalised by eight subscales of the McCloskey/Mueller Satisfaction Scale. 2. Nurses were asked to rate how often they considered leaving their actual workplace, the nursing profession and working abroad on a scale ranging from 0.	31 items	Czech = 0.92 Slovak = 0.91	Previously validated	1. Pearson's correlation 2. Multiple regression analysis 3. ANOVA 4. Fisher's least significant difference	1. The intention to leave the workplace, the nursing profession and work were predicted by the levels of satisfaction of nurses with their control/responsibility and scheduling. 2. Czech nurses reported higher satisfaction in all subscales of the job satisfaction and less frequent intention to work abroad. 3. An inverse relationship was confirmed between age and turnover intentions. 4. Job satisfaction was positively associated with age and years of experience. 5. Job satisfaction differed by all three turnover intentions.

Author (Year) Journal and Country Study Design	Theoretical Model	Sample/ Sampling Method/ Setting	Measurement /Instruments	Scoring	Reliability (Cronbach's alpha)	Validity	Analysis	Significant Findings
Ma, Lee, Yang & Chang (2009)  Nursing Economics  Taiwan  Cross sectional questionnaire	None	1019 valid survey returned. 63.4% response rate. This study was conducted in a non- profit organisation affiliated with the Presbyterian Church in four hospitals in Taiwan.	1. A two-part questionnaire including demographics and three questions asking: (a) How would you rate the current quality of patient care in your unit? (1 = extremely bad and 10 = extremely good); (b) Are you satisfied with your current job? (1 = very dissatisfied and 10 = very satisfied); (c) Are you considering leaving your current job in the coming year? (1 = no and 2 = planning to leave current job).	14 items	Not reported	Not reported	1. Descriptive statistics 2. Chi-square test 3. Independent t-test 4. Logistic regression	1. The results of logistic regression analysis revealed that age, working evening shift, and level of job satisfaction were significant in predicting whether or not a nurse intended to leave a current job.
Mosadeghrad & Ferdosi (2013)  Mat Soc Med  Iran  Cross sectional study	None	832 surveys returned.  Response rate of 85.68%.  All University hospitals in Isfahan city (12) participated in this study.	1. The Job Satisfaction Scale. 2. Organisational Commitment Scale. 3. Managers Leadership Scale.	36 items  24 items  35 items	0.87  0.87  0.81-0.87	Validated in Persian language	In order to normalise the Likert scale on 1- 6 scales for each domain of job satisfaction and commitment surveys, the sum of raw scores of items in each domain was divided by the numbers of items in each domain and for overall job satisfaction and commitment, sum of raw scores of items was divided by 36 and 24 respectively.	1. Leadership, job satisfaction and commitment were closely interrelated. The leadership behaviour of managers explained 28% and 20% of the variations in job satisfaction and organisational commitment respectively.

Author (Year) Journal and Country Study Design	Theoretical Model	Sample/ Sampling Method/ Setting	Measurement /Instruments	Scoring	Reliability (Cronbach's alpha)	Validity	Analysis	Significant Findings
Ramoo, Abdullah & Piaw (2013)  Journal of Critical Nursing  Malaysia  Cross sectional survey	Motivation hygiene theory	141 Response 94% response rate. Hospital in Malaysia	1. Demographics Section 2. Researchers adapted the National Database of Nursing Quality Indicators – Adapted Index of Work Satisfaction (NDNQI-AIWS) 3. Index of Work Satisfaction and the Revised Nursing Work Index. 4. Motivation and hygiene factors 5. Questionnaire contained a statement regarding nurses' job plans for the next three years with eight options	4 items  60 items	0.81-0.87     0.94-0.95  0.91	Not reported	Mean MANOVA Spearman's rho Chi-square test Hierarchical logistic regression	1. The results suggest that there is a significant association between job satisfaction and nurses' intention to leave their current employment.
Wang, Ellenbecker & Liu (2012)  Journal of Advanced Nursing  Shanghai  Descriptive correlation design	None	560 nurses completed the survey. Response rate 90%. Four large hospital facilities in Shanghai.	1. The Chinese Nurses Job Satisfaction Scale (NJSS). 2. Mueller Satisfaction Scale (MMSS). 3. The HHNJS was designed to measure job satisfaction among home health care nurses. 4. Occupational Commitment was measured with the Chinese version of the Occupational Commitment Scale. 5. Nurses' intent to stay (ITS) was measured with an adapted Intent to Quit and Job Search Scales.	38 items  31 items  32 items  25 items  6 items	0.881    0.884  0.785	Validity used for intent to quit and job search scales	Descriptive statistics Spearman's correlation	1. A statistically significant positive correlation was found between occupational commitment and job satisfaction. 2. Age and job position were significantly related to job satisfaction, occupational commitment and intent to stay.

<b>Author (Year) Journal and Country Study Design</b>	<b>Theoretical Model</b>	<b>Sample/ Sampling Method/ Setting</b>	<b>Measurement /Instruments</b>	<b>Scoring</b>	<b>Reliability (Cronbach's alpha)</b>	<b>Validity</b>	<b>Analysis</b>	<b>Significant Findings</b>
Hazell (2010)  United States of America  Non-experimental and exploratory online survey	Burnout theory	129 respondents for a 0.45% response rate. Accessible population of approximately. 28,511 Florida licensed hospital employed registered nurses were invited to participate in the survey.	1. Demographic Characteristics. 2. Work Profile Characteristics = developed by researcher. 3. Job Stress = ENSS. 4. Burnout Inventory - Human Service Survey (MBI-HSS). 5. Job satisfaction = The Professional Turnover Questionnaire (PTQ). 6. Intention to Leave= the Intention to Leave Scale.	7 items  7 Items  57 items 22 items  7 items  4 items	  0.974  0.842 0.884  0.874	Previous validity results used	1. Exploratory data analysis, 2. Descriptive statistics, independent t tests and one-way ANOVA were used. 3. Stepwise hierarchical multiple regression was used to find the best explanatory models	1. Job Satisfaction was the most significant explanatory variable of 'Intention to Leave'.

Each quantitative study was reviewed using an adapted quality rating tool used in previous nursing knowledge translation and leadership systematic review studies (Cowden et al., 2011; Cummings & Estabrooks, 2003; Estabrooks, Floyd, Scott-Findlay, O'Leary, & Gushta, 2003). The tool, with permission, was adapted for this study to allow for the quality of research articles exploring organisational communication and the impact on nurses' job satisfaction and intention to stay in their current job, to be assessed. The adapted tool was used to assess four areas of each study; research design, sampling, measurement and statistical analysis. The tool comprised of 13 items that could score a possible 14 points. For item "measurement of job satisfaction and intention to stay observed rather than reported", observed was given two points, reported one point and articles including neither of these scored zero. All other items were scored one for 'met' (yes) or a zero for 'not met' (no). Based on this point system a study was categorised into one of three possible categories. A score of 0-4 was classed as a low-quality study, a score of 5-9 a medium quality study and a score of 10-14 a high-quality study. Only studies that were rated as moderate or high in quality were retained for this systematic review (See Table 4 for quality tool).

**Table 4: Adapted quality assessment used for included quantitative studies**

	No	Yes
Design <ul style="list-style-type: none"> <li>• Is the study prospective?</li> <li>• Is probability sampling used?</li> </ul>		
Sample <ul style="list-style-type: none"> <li>• Is the sample size justified?</li> <li>• Is the sample drawn from more than one site?</li> <li>• Is participant anonymity protected?</li> <li>• Is the response rate greater than 60%?</li> </ul>		
Measurement Independent variable <ul style="list-style-type: none"> <li>• Is the independent variable measured reliably?</li> <li>• Is the independent variable measured using a valid instrument?</li> </ul> Dependent variable <ul style="list-style-type: none"> <li>• Is the outcome variable observed rather than self-reported?</li> <li>• If the scale is used measuring an outcome is internal consistency &gt; .70?</li> <li>• Is a theoretical model/framework used to guide the study?</li> </ul>		

Statistical analysis <ul style="list-style-type: none"> <li>• If multiple outcomes are studied are correlations analysed?</li> <li>• Were outliers managed?</li> </ul>	
Overall study quality 0-4 low 5-9 moderate 10-14 high	

Adapted with permission from Estabrooks, Floyd, Scott-Findlay, O'Leary, & Gushta, 2003

The following data was extracted from the qualitative studies; author, date, journal article published in paradigm/philosophy to structure knowledge and understanding, methodologies and main outcomes (See Table 6). The qualitative studies were reviewed for quality using the Joanna Briggs Institute critical appraisal checklist for qualitative research. See Table 5. This process involved examining the articles for technical rigour, reporting detail, researchers' response to data and theoretical consistency (Joanna Briggs Institute, 2017).

**Table 5: Joanna Briggs Institute appraisal checklist for qualitative research**

Reviewer \_\_\_\_\_ Date \_\_\_\_\_

Author \_\_\_\_\_ Year \_\_\_\_\_ Record Number \_\_\_\_\_

	Yes	No	Unclear	Not applicable
1. Is there congruity between the stated philosophical perspective and the research methodology?	<input type="checkbox"/>	<input type="checkbox"/>	<input type="checkbox"/>	<input type="checkbox"/>
2. Is there congruity between the research methodology and the research question or objectives?	<input type="checkbox"/>	<input type="checkbox"/>	<input type="checkbox"/>	<input type="checkbox"/>
3. Is there congruity between the research methodology and the methods used to collect data?	<input type="checkbox"/>	<input type="checkbox"/>	<input type="checkbox"/>	<input type="checkbox"/>
4. Is there congruity between the research methodology and the representation and analysis of data?	<input type="checkbox"/>	<input type="checkbox"/>	<input type="checkbox"/>	<input type="checkbox"/>
5. Is there congruity between the research methodology and the interpretation of results?	<input type="checkbox"/>	<input type="checkbox"/>	<input type="checkbox"/>	<input type="checkbox"/>
6. Is there a statement locating the researcher culturally or theoretically?	<input type="checkbox"/>	<input type="checkbox"/>	<input type="checkbox"/>	<input type="checkbox"/>
7. Is the influence of the researcher on the research, and vice-versa, addressed?	<input type="checkbox"/>	<input type="checkbox"/>	<input type="checkbox"/>	<input type="checkbox"/>
8. Are participants, and their voices, adequately represented?	<input type="checkbox"/>	<input type="checkbox"/>	<input type="checkbox"/>	<input type="checkbox"/>
9. Is the research ethical according to current criteria or, for recent studies, and is there evidence of ethical approval by an appropriate body?	<input type="checkbox"/>	<input type="checkbox"/>	<input type="checkbox"/>	<input type="checkbox"/>
10. Do the conclusions drawn in the research report flow from the analysis, or interpretation, of the data?	<input type="checkbox"/>	<input type="checkbox"/>	<input type="checkbox"/>	<input type="checkbox"/>

Overall appraisal:      Include       Exclude       Seek further info

Comments (Including reason for exclusion)

---



---



---

**Table 6: Qualitative article summary**

Author (Date) Journal Country	Design/Size	Data Collection Methods	Main Outcomes
<b>Theme 1 Impact of organisational communication on nurses' job satisfaction and intention to stay in one's job</b>			
Feather, Ebright & Bakas (2015)  Nursing Forum  United States of America	A qualitative descriptive design. Total of 28 RNs provide data that were coded through qualitative content analysis for themes. Two organisations	Five focus groups were conducted through semi-structured interviews of a total of 28 RNs to provide data that were coded through qualitative content analysis for themes.	The theme of communication was identified through the RNs' discussion of the need to be made aware of the decision-making that was occurring within their organisation.  The RNs desired communication in which managers were consistent in what they said and did, listened to the personal and professional needs of the staff, responded by promoting open discussion within the unit, and maintained confidentiality, all of which promoted trust.  Communication was absent when the staff felt excluded and unaware of decisions being made within the organisation.  This type of behaviour, as perceived by the RNs, resulted in a lack of trust between the staff and the management.
Tourish & Hargie (1996)  United Kingdom  Journal of Management in Medicine	Case study from one NHS trust. 164 respondents returned the surveys. 5.5% of the NHS trust population.	Open ended survey questions.	High levels of dissatisfaction amongst all staff in the Trust. Not enough information. Not enough time. Insufficient contact with senior management. Felt excluded from decisions made about their work. The negative feelings extended to managerial staff. When communication was effective staff appreciated it. Staff wanted regular staff meetings. Clarity of organisational structure. <u>Facilitators</u>

			<p>Staff and managers trained in communication skills.</p> <p>Informed and consulted about change.</p> <p>Relevant and targeted information with pays.</p> <p>More bottom up communication.</p> <p>More seminars.</p> <p>More staff involvement in designs.</p>
<b>Theme 2 Facilitators of effective communication</b>			
<p>Adelman (2010)</p> <p>Proquest</p> <p>United States of America</p>	<p>The study was exploratory in nature utilising a Phenomenological collective case study approach.</p> <p>Four different performance excellence award-winning healthcare organisations comprised the cases studied.</p> <p>20 semi structured interviews with members of the organisations provided data for the study.</p>	<p>Data collection procedures for the study focused on capturing both textural and structural descriptions surrounding the behaviours and actions of the CEO with regard to critical upward communication and promotion of employee voice within the performance excellence award-winning healthcare organisation.</p>	<p>The results suggested the award-winning CEOs facilitated employee voice and upward communication by being approachable, largely achieved through their regular presence throughout their organisation.</p> <p>By being consistently visible and available to employees, these CEOs fostered relationships, built trust, and promoted open, upward communication. Leaders in the current case studies created a cultural focus on continuous improvement largely built around transparency of information, and particularly looking for the bad news from their employees.</p> <p>Voice invitation and positive voice response from leaders reinforced critical upward feedback as not only welcome, but expected.</p>
<b>Theme 3 Nurses and managers experience of organisational communication</b>			
<p>Hartung &amp; Miller (2013)</p> <p>The Journal of Nursing Administration</p> <p>United States of America</p>	<p>A descriptive qualitative study.</p> <p>One tertiary care centre.</p> <p>12 interview with nurse managers.</p>	<p>During the 2nd interview, the participant reviewed the initial transcript as transcribed by the non-nurse research coordinator for verification or correction.</p> <p>The participant was also verbally given a description of the researchers' initial data categories, and the participant verified and clarified the researchers' understanding of the NM perspectives.</p>	<p>5 themes were identified</p> <p>Workplace processes were identified that either promoted or hindered managers' abilities to set a positive tone and to stay connected to their staff, ensuring effective communication while meeting multiple unit and institutional challenges.</p>



<p>Garon (2012)</p> <p>Journal of Nursing Management</p> <p>United States of America</p>	<p>Descriptive qualitative study.</p> <p>33 registered nurses (RNs), in staff or management positions from a variety of healthcare settings in California.</p>	<p>Group interviews</p>	<p>Three categories: influences on speaking up, transmission and reception of a message and outcomes or results.</p> <p>The present study supported the importance of the manager in setting the culture of open communication.</p>
<p>Marx (2014)</p> <p>Journal of Nursing Management</p> <p>United States of America</p>	<p>Qualitative study.</p> <p>Purposive sampling of all managers in two hospitals face to face interviews with 14 first-line managers at the two hospitals were conducted from February to July 2007.</p>	<p>The data was collected using face-to-face interviews with first-line managers at two US hospitals. The interviews were transcribed and coded with limited use of the qualitative software ATLAS Interview questions focused on work experiences of managers with special emphases on communication.</p>	<p>Structural barriers that influenced managers' communication included the amount of face-to-face interaction with nurses, the amount of information to communicate, levels of formalisation, outreach to all nurses, time constraints and nurses' subcultural networks.</p> <p>These factors compromised managers' ability to communicate effectively with nurses.</p>

## RESULTS

### Search results

The initial electronic database and manual search yielded 10,727 abstracts and titles. Following removal of duplicates, the articles were reviewed for title and abstract against the inclusion criteria and 208 manuscripts were retrieved. After the initial review against title, abstract and keywords, 78 articles were retained for full article review. There was a total of 28 manuscripts retained for inclusion and data extraction. Of the included manuscripts, 22 were quantitative and six were qualitative. It was apparent during review of the literature that some areas of this topic have not been explored in paediatric nursing or healthcare during the 21<sup>st</sup> century, resulting in dated references.

#### *Summary of quantitative quality review*

All of the included quantitative research papers were reviewed using the adapted quality rating tool by Estabrooks, and colleagues (2003). All of the 22 quantitative

articles scored moderate (between five and nine) on the quality rating tool indicating weaknesses within the articles. Two major weakness were shared across the 22 quantitative studies, one regarding measurement and the other regarding data analysis. These weaknesses included none of the studies being prospective in nature and none using probability sampling. In addition, all research reports failed to address the possibility that outliers influenced results. Other weaknesses that emerged during the review included:

- 1) only eight of the studies used a theoretical model or framework to guide the study,
- 2) twelve studies used correlations to analyse data,
- 3) six studies did not mention the research design used in the study, and
- 4) only 12 of the 22 articles mentioned protecting anonymity and confidentiality of data.

The strengths in this set of studies included the fact that 20 studies justified the sample size, and 73% of the studies drew their sample from more than one site with two studies being carried out between hospitals in two different countries. Additional strengths include:

- 1) 55% of studies had more than 60% response rate,
- 2) Nineteen out of 22 studies used surveys that were previously validates,
- 3) Seventeen of the studies mentioned the validity of the surveys used, and
- 4) Seventeen of the studies demonstrated high internal consistency of the instruments used for data collection.

#### *Summary of qualitative papers*

There were six qualitative papers collected for this review. Five of the six studies were conducted in the United States of America and one was conducted in the United Kingdom. Four were conducted at more than one hospital and two studies were conducted at the one location. Three studies used a descriptive design, one used a phenomenological design and one used a case study design and one did not mention the qualitative design used. Two of the studies collected data through focus groups, three used interviews and one used an open-ended survey.

### *Summary of findings*

Due to a lack of consistency in methods and ways of reporting it was not possible to analyse the data using meta-analysis. Textual Narrative Synthesis is useful in drawing together different types of research evidence including both quantitative and qualitative research findings (Munn, Tufanaru, & Aromataris, 2014). Therefore, the results from this systematic review were summarised narratively, comparing results where applicable. The literature was categorised into the following four themes; the impact of organisational communication on job satisfaction and intention to stay in one's job, facilitators of effective organisational communication, nurses and managers experience of organisational communication and relationship between job satisfaction and intention to stay in one's job.

#### Impact of organisational communication on nurses' job satisfaction and intention to stay

The results of this review highlight the importance of communication within an organisation on nurses' job satisfaction (Pincus, 1986), turnover intentions and commitment to the organisation (Naz & Gul, 2014; Varona, 1996). Specifically, the quality of information received from supervisors and upper management is especially important in terms of employees organisational involvement, job satisfaction (Frone & Major, 1988; Varona, 1996), and turnover intentions (Naz & Gul, 2014; Pincus, 1986), with up to 40.4% variance in job satisfaction being explained by leader-member exchange quality (Spence-Laschinger, Purdy, & Almost, 2007). Leader-member exchange includes, job related tasks, feedback, encouragements, and hearing the subordinates' personal and occupational problems (Naz & Gul, 2014). Similarly, Brunetto and colleagues (2011) identified that 24.6% of variance of nurses' affective commitment was related to supervisor communication, supervisor ambiguity and discretionary power. The data also showed that 61.4% of the role ambiguity related to supervisors was due to the supervisor communication relationship.

Worryingly, 50% of nurses in a Lebanese study highlighted that nurses reported inadequate communication with their superiors (Kaddourah, Khalidi, Abu-Shaheen, & Al-Tannir, 2013). Likewise, a qualitative study (Feather, Ebright, & Bakas, 2015), identified that RN's wanted to be made more aware of decisions being made within the organisation. When nurses felt unaware and excluded from organisational decision making, a lack of trust with staff and management ensued. The nurses wanted communication in which managers were consistent, listened to their needs, responded

with open discussion, maintained confidentiality and promoted trust, which contribute to level of job satisfaction (Feather et al., 2015).

Further, high levels of dissatisfaction with communication were found to be present among both staff nurses and managers in a study conducted in the NHS (National Health Service). They identified not enough information, not enough time, insufficient contact with senior management and feeling excluded from decisions made about their work. These negative feelings extended to managerial staff as well, stating that “no one appears to know what is happening from the top down. There appears to be no organised communication”. This dissatisfaction was found to be a contributing factor to nursing frustrations (Tourish & Hargie, 1996). These themes somewhat mirrored in a study of communication across the perioperative pathway (Braff et al., 2012), in which respondents were dissatisfied with communication from top management, including restrictions in communication flow, timing of communication and amount of information received.

Communication climate (Pincus, 1986), organisational integration, media quality, organisational perspective, (Varona, 1996), and horizontal communication (Frone & Major, 1988; Naz & Gul, 2014), have also been identified as significant predictors of commitment (Varona, 1996), although less discussed in previous research.

#### Facilitators of effective organisational communication

This section will present the facilitators of effective organisational communication as identified within the literature.

Hospital Magnet designation was identified as a facilitator of effective communication due to greater visibility and responsiveness by nurse leaders (Upendicks, 2002). Likewise, award winning CEOs in healthcare organisations promoted upward communication by being approachable and having a regular presence throughout the organisation, which fostered relationships between employees and the CEOs. Employees felt listened to and respected, especially when the CEO proactively sought out their input (Adelman, 2010). The notion of openness, supportive and communicative work environments to promote nurses’ dignity and respect (Rouse & Al-Maqbali, 2014), has been found to promote positive communication with top managers shaping the culture of communication within an organisation (Garon, 2012). Leaders that create a cultural focus on continuous improvement largely built around

transparency of information, voice invitation and positive voice response, reinforce critical upward feedback as not only welcome, but expected (Frone & Major, 1988).

In addition, communication skills training showed a statistically significant difference between control and experimental groups after intervention. The results showed that the training of communication skills can increase the nurse's rate of communication skills and cause elevation in quality of nursing care (Khodadadi, Ebrahimi, Moghaddasian, & Babapour, 2013). Similarly, team building activities were found to assist nurse leaders and managers to build cohesive teams by strengthening communication and interpersonal relationships. As a result, a reduction in turnover intentions were noticed (Amos et al., 2005). Likewise, participants in a study in Ireland felt that communication with management would be improved if managers were trained in communication skills (Tourish & Hargie, 1996), with higher communication competence being linked to a reduction in stress and an increase in job satisfaction (Wright, 2011). Further, Chang and Chang (2009) highlighted that effective internal marketing offers good communication channels, establishes good enterprise culture, and treats nurses cordially as internal customers, which also has the added benefit of increasing personal commitment.

#### Nurses' and managers' experience of organisational communication

The review supported the notion that supervisors and staff viewed organisational communication differently, with supervisors being significantly more satisfied than subordinates with overall communication practices (Varona, 1996). Managers felt that there were numerous structural barriers that compromised their ability to communicate with nurses. These barriers included the amount of face-to-face interaction with nurses, the amount and quality of information to communicate, levels of formalisation, outreach to all nurses, time constraints and nurses' subcultural networks (Marx, 2014). Hartung & Miller (2013) identified similar themes with managers identifying workplace processes to either promote or hinder their abilities to set a positive tone and stay connected with their staff whilst meeting unit and institutional challenges. However, senior management themselves have reported that they have less power and information than was commonly imagined by ward nurses (Tourish & Hargie, 1996).

Ward nurses on the other hand felt that there was a significant discrepancy between the amount of information that they received and the amount that was needed to do the job successfully. Overall, nurses desire more information through the major

communication channels, particularly those channels that involve direct contact with their immediate managers and senior managers; becoming more involved with expressing concerns and evaluating general systems and the roles of senior managers above them (Tourish & Mulholland, 1997). Similarly, the respondents in one study highlighted that staff nurses wanted to know that the issues they had raised were acted upon with several expressing feelings of ‘nothing ever changes’ which results in nurses feeling like they are wasting time and energy in bringing issues up (Garon, 2012).

#### The relationship between job satisfaction and intention to stay

The results of this review suggest that there is a significant association between job satisfaction and nurses’ intention to leave their current employment (Hazell, 2010; Ramoo et al., 2013; Wang et al., 2012). Mosadeghrad and Ferdosi (2013), found that leadership behaviour of managers explained 28% and 20% of the variations in job satisfaction and organisational commitment respectively. The intention to leave the workplace, the nursing profession and work abroad were predicted by the levels of satisfaction of nurses with their control, responsibility and scheduling (Gurková et al., 2013).

The demographics of age (Gurková et al., 2013; Ma, Samuels, & Alexander, 2003; Wang et al., 2012), working evening shifts, job position (Wang et al., 2012) years of experience (Gurková et al., 2013) and level of job satisfaction were significant in predicting whether or not a nurse intended to leave a current job (Ma et al., 2003).

## **DISCUSSION**

The systematic review reported provides the first on this topic relative to the nursing context. The included studies confirm that organisational communication satisfaction impacts on nurses’ job satisfaction and nurses’ intention to stay in their current job. Specifically, supervisor-subordinate relationships have a strong impact with top managers controlling the communication culture of an organisation. Interestingly this present review highlighted the difference in communication perceptions between managers and ward staff, with managers being significantly more satisfied with communication than subordinates. In comparison, ward nurses felt there was a significant discrepancy between the amount of information that they received and the amount that was needed to do the job successfully. Management visibility, openness, support and Magnet designation of a hospital were also identified as facilitators of

effective organisational communication. The link between job satisfaction and intention to stay was also supported.

Nonetheless, there is a paucity of research exploring paediatric nurses' perception of organisational communication, and its impact on job satisfaction and paediatric nurses' intention to stay in their current job. This has implications for both nursing practice, and nursing research.

### **Implications for nursing practice**

The shortage of nurses is predicted to continue into the future, with Australia still needing a predicted 85,357 registered and enrolled nurses by 2025 (Health Workforce Australia, 2014). It is of vital importance that efforts to retain nursing staff becomes a top priority for management, as nurses who are dissatisfied with their jobs are more likely to leave, either the organisation they are dissatisfied with or the profession of nursing itself (Abualrub & Alghamdi, 2012). The literature confirms that there is a positive relationship between organisational communication satisfaction and job satisfaction (Frone & Major, 1988; Pincus, 1986) and a negative relationship between organisational communication and intention to stay (Pincus, 1986; Varona, 1996). Specifically, it is supervisor communication (Adelman, 2010; Feather et al., 2015; Pincus, 1986; Rouse & Al-Maqbali, 2014; Spence-Laschinger et al., 2007), personal feedback and communication climate that impacts on job satisfaction, and co-worker and top management communication that impacts on intention to stay (Brunetto et al., 2011; Pincus, 1986). In addition, nurses desire more information through the major communication channels, particularly those channels that involve direct contact with their immediate managers and senior managers; being able to express concerns and evaluate the roles of senior managers above (Braff et al., 2012; Kaddourah et al., 2013; Tourish & Hargie, 1996; Tourish & Mulholland, 1997; Upendicks, 2002).

Communication is a fundamental element of care at every level of nursing practice. It is therefore of vital importance for communication channels between managers and nurses to be open (Adelman, 2010; Mrayyan, 2008; Tourish & Hargie, 1996). By maintaining open communication, nurses have greater work satisfaction and work commitment (Batch, 2012; Davidson et al., 1997) outcomes that favour the organisation (Gray & Laidlaw, 2004). Effective communication within a healthcare organisation should be a core management concern as it allows an organisation to become more cohesive and enhances its ability to achieve goals and objectives (Tourish

& Mulholland, 1997). Therefore, management and administrators need to implement effective communication strategies, such as open lines of communication with subordinates (Adelman, 2010; Feather et al., 2015; Mrayyan, 2008; Tourish & Hargie, 1996), team building exercises (Amos et al., 2005) and skill development (Khodadadi et al., 2013) as a means of increasing job satisfaction and nursing retention.

### **Implications for nursing research**

There is a paucity of literature on this topic with only a few articles meeting the inclusion criteria developed for this systematic review. Specifically, there were only eight articles that discussed organisational communication satisfaction, job satisfaction and intention to stay or organisational commitment, with most only discussing one aspect of organisational communication, such as supervisor relationships, instead of the concept or organisational communication as a whole. The studies that were included were also limited due to the design, sampling and analysis as none of the studies utilised random sampling methods. Additional activities to increase response rates would improve reliability of the results and strengthen data analysis. The difficulty of this should be acknowledged as the expected response rate for questionnaire completion in nursing is between 42% and 53% (Aiken et al., 2002). Likewise, drawing a sample from more than one site should continue in future research as the diversity of multiple settings strengthens the validity and generalisability of study findings. Not all of the included studies mentioned validity and reliability of the tools, nor mentioned how outliers were managed, which may also limit the generalisability of the findings. Overall, the impact of communication satisfaction on nurses' job satisfaction and intention to stay in nursing needs further study and the literature would benefit from greater quality of research being conducted.

### **LIMITATIONS**

This systematic review was limited to English language studies which may have resulted in some studies of relevance being missed. Likewise, not all journals discussing the topic of interest were accessible resulting in these articles being left out of the review. There were many studies that discussed some aspects of the impact of organisational communication satisfaction on nurses' job satisfaction and intention to stay that were not included in this review as they did not comprise a full evaluation of organisational communication. However, it may be that some of these excluded papers would still aid an understanding of the topic. Additional qualitative research on the



topic would also be beneficial to further develop the lived experiences of nurses in relation to communication satisfaction and strategies for future improvement.

## **SYSTEMATIC REVIEW CONCLUSIONS**

The findings of this systematic review point to a significant positive relationship between organisational communication satisfaction and job satisfaction as well as a negative relationship between communication satisfaction and turnover intentions. There is a dearth of published studies in this area, specifically within paediatric nursing over the last decade; however, the results of this review highlight the importance of supervisor relationships in effective organisational communication. It is important to explore satisfaction in the paediatric setting as paediatric nurses have been noted to have above average levels of occupational stress, which can result in poor health and increased turnover intention (Mohammad Mosadeghrad, 2014). As healthcare faces looming shortages in nursing, it is vital to understand all of the influences on paediatric nurse retention. Therefore, further research should be conducted exploring the effects of organisational communication on nurse's job satisfaction and nurses' intention to leave their current job.

## **SUMMARY**

This chapter examined the literature surrounding nurses' and middle managers' satisfaction with organisational communication and the effect this has on nurses' job satisfaction and intention to stay in their current jobs. Organisational theory and communication literature were reviewed to provide a context for the current study including, organisational design and structures, communication and organisational communication. It was apparent during review of the literature that some areas of this study have not been explored or investigated in nursing or healthcare during this century, resulting in dated references. Whilst there was a documented connection between job satisfaction, work commitment and communication (Amos et al., 2005; Brooks, 2002) there is currently limited literature exploring nurses' (and more specifically, paediatric nurses') satisfaction with organisational communication and the effect this has on job satisfaction and intention to stay.

Due to the lack of literature surrounding paediatric nurses' satisfaction with organisational communication and its impact on their intention to stay in their current job

The aim of this study was to identify the impact that communication satisfaction has on paediatric nurses' job satisfaction and intention to stay. In doing so it is hoped that this study will fill the current gap in the literature and that recommendations can be made that may assist in nursing retention strategies in the paediatric setting. Chapter 3 will examine the methods and materials that were used to undertake the research.

---

## **CHAPTER 3: METHODS AND MATERIALS**

### **INTRODUCTION**

This chapter introduces the methods and materials that were used to answer the research questions and achieve the desirable outcomes. Included in this chapter are the study design, theoretical model, data collection, analysis, sampling, reliability and validity, and the target population. This chapter will also review the ethics and standards that were maintained and study limitations experienced.

### **STUDY DESIGN**

A study's design is guided by the research problem and the research questions being investigated and can adopt either a qualitative, quantitative or mixed method approach. A qualitative design focuses on understanding the complexity of humans within the context of their lives and is usually an interactive process seeking to obtain opinions, experiences and perspectives (Macnee, 2004). Qualitative studies are described as providing strong evidence for the truth of a conclusion and are considered to be exploratory (Watson, Mckenna, Cowman, & Keady, 2008). In contrast, a quantitative design focuses on breaking down and understanding the different parts of a picture and involves numerical data and statistics (Macnee, 2004). Quantitative research uses hypothesis and theories to assess cause and effect relationships or correlations (Harvey & Land, 2016). The study design selected for a study depends on the theoretical perspective chosen by the researcher and the topic of interest or phenomena (Watson et al., 2008).

For this study, a cross-sectional quantitative research design was used, whereby the data was collected at one point in time from paediatric nurses and middle (nursing) managers working in the only tertiary paediatric hospital in Western Australia. The data was collected through the use of online surveys. This was considered the most appropriate research design based on the aims of study, which were to investigate paediatric nurses' and middle managers' satisfaction with organisational communication and the impact this has on paediatric nurses' job satisfaction and intention to stay in their current job. The second aim was to assess if there is a difference in organisational communication satisfaction between paediatric nurses and

middle managers, different educational experience, years of nursing and managerial experience, contracted hours, area of work, age and gender.

## **THEORETICAL MODEL**

A sound model for managing quantitative research data is theory-based from findings in the literature, knowledge in the field, or one's educated guesses, from which cause and effects among variables within a theory are specified (Lei & Wu, 2007). In a graphical model a directional arrow ( → ) is used to represent a hypothesised causal relationship between variables. The variable to which the arrow is pointing is known as an endogenous variable or dependent variable, and variables with no arrow pointing to them are known as an exogenous or independent variables. Latent variables or variables that are not directly observed can also be measured in a model (Lei & Wu, 2007). The hypothesised conceptual models for this study were created from a review of theoretical and empirical literature. The literature review indicated that positive and effective communication leads to an increase in work satisfaction and work commitment (Batch, 2012; Davidson et al., 1997). Additionally, middle managers must effectively communicate with upper management, their peers, and maintain communication, thereby facilitating communication within an organisation (Awad et al., 2005). Furthermore, by maintaining open (Mrayyan, 2008) and effective communication (Chu et al., 2003), nursing retention and reduction in nursing turnover can be achieved (Jasper, 2007). Although no paediatric research has been identified through the systematic review, the findings from general nursing literature were used as the basis to construct a hypothesised conceptual model (Figure 2) on the premise that paediatric nurses' organisational communication satisfaction has a direct impact on job satisfaction and intention to stay. For this conceptual model the endogenous variables are paediatric nurses' job satisfaction, paediatric nurses' intention to leave their present job and paediatric nurses actively looking for another job. The exogenous variable is communication satisfaction. Communication satisfaction is measured through six constructs:

- 1) Communication climate
- 2) Horizontal communication
- 3) Media quality
- 4) Organisational integration
- 5) Supervisor relationships
- 6) Corporate perspective

Nurses' intention to stay is measured through their intention to leave and looking for another job. It is hypothesised in the conceptual model that each of these constructs will impact individually on paediatric nurses' job satisfaction and intention to leave as well as looking for another job. Control variables have been used in the study to examine the relationship between organisational communication satisfaction and paediatric nurses' demographics. For this study the control variables of age, highest level of education, years of experience, position, area of work, employment status were used. Gender was not used as a control variable as nursing is a female dominant profession, with only 10% of nurses working in Australia being male (Australian Bureau of Statistics, 2013). Numbers are similar in the United Kingdom and United States of America with 10.2% and 5% respectfully (Needleman, Buerhaus, Mattke, Stewart, & Zelevinsky, 2002; Oxtoby, 2003). Due to this, gender would not have been equally represented within the sample and therefore would not provide a true indication of the relationship between gender and organisational communication satisfaction. The controls were included in the SEM analysis from the beginning and were covaried with other exogenous variables, namely the six factors of communication satisfaction and each control variable. This allowed the controls to be imposed on the endogenous constructs, job satisfaction, intention to leave and looking for another job. Figure 2 was used to answer research question two and illustrates the hypothesised model between organisational communication satisfaction, job satisfaction, intention to leave one's job and looking for another job. Figure 3 illustrates the hypothesised model between job satisfaction, intention to leave one's job and looking for another job. This model was developed based on previous literature and was used to answer research question three.

## **RESEARCH QUESTIONS AND HYPOTHESIS**

There are three research questions addressed in this study:

- 1) How satisfied are paediatric nurses and middle managers with organisational communication?
- 2) What effect does satisfaction with organisational communication have on paediatric nurses' job satisfaction and intention to leave their current job and looking for another job?
- 3) What is the relationship between job satisfaction, intention to leave and looking for another job?

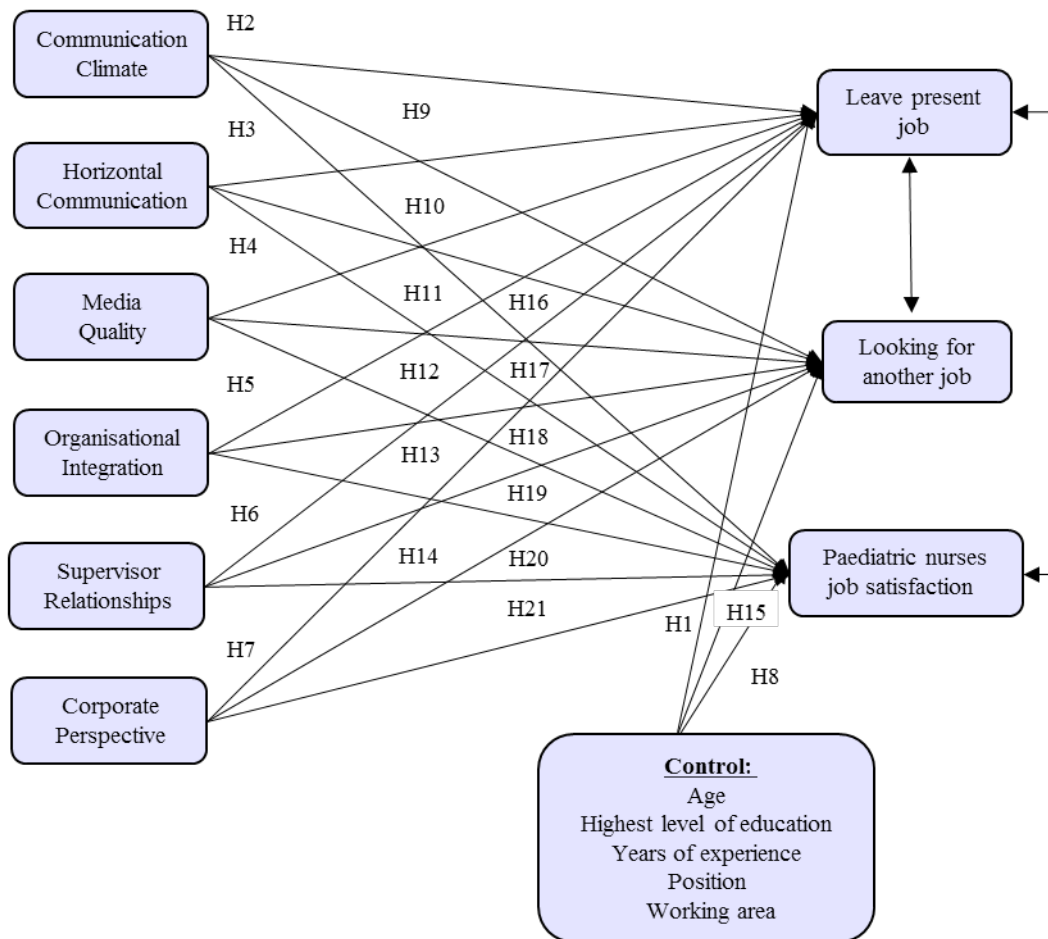

**Figure 2: Organisational communication satisfaction and effect hypothesised conceptual model**

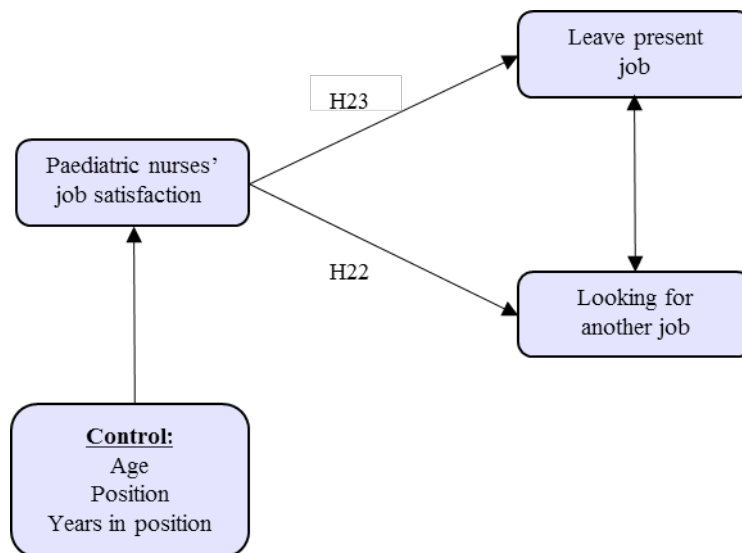

**Figure 3: Relationship between paediatric nurses' job satisfaction and intention to leave and looking for another job hypothesised conceptual model**

## Hypotheses

In order to answer the research questions above, the following directional hypotheses were developed. Each hypothesis indicates a pathway and is stated according to the outcomes of job satisfaction and intention to leave their current job. Included in the hypothesis is each of the six constructs that make up communication satisfaction and the expected effect on job satisfaction and intention to leave their current position or looking for another job. The terms positive and negative were used to anticipate the relationships. In a positive relationship, as one variable increases, the other increases, and as one variable decreases the other variable decreases. In contrast, in a negative or inverse relationship, the two variables move in opposite directions i.e. As one variable increases the other variable decreases (Le Roy, 2013). The hypotheses were developed based on the premise that the communication satisfaction subscales will have a direct and positive relationship on job satisfaction, a direct and negative relationship on intention to stay and looking for another job. The controls variables of highest level of education, years of experience, age, position and working area were used as individual variables within the SEM analysis from the beginning and were covaried with other exogenous variables, namely the six factors of communication satisfaction and each control variable. It was predicted that the control variables would have a positive relationship with job satisfaction and a negative relationship with intention to stay and looking for another job. In order to answer the research questions above, the following directional hypotheses were developed from current nursing literature.

### *Intention to leave*

- H1 - Highest level of education, years of experience, age, position and working area (controls) are individually, negatively related to paediatric nurses looking for a new job.
- H2 - Communication climate is negatively related to paediatric nurses' intention to leave their current job.
- H3 - Horizontal communication is negatively related to paediatric nurses' intention to leave their current job.
- H4 - Media quality is negatively related to paediatric nurses' intention to leave their current job.
- H5 - Supervisor relationships are negatively related to paediatric nurses' intention to leave their current job.

- H6 - Organisational communication is negatively related to paediatric nurses' intention to leave their current job.
- H7 - Corporate perspective is negatively related to paediatric nurses' intention to leave their current job.

*Job satisfaction*

- H8 - Highest level of education, years of experience, age, position and working area (controls) are positively related to paediatric nurses' job satisfaction.
- H9 - Organisational communication is positively related to paediatric nurses' job satisfaction.
- H10 - Horizontal communication is positively related to paediatric nurses' job satisfaction.
- H11 - Supervisor relationships are positively related to paediatric nurses' job satisfaction.
- H12 - Media quality is positively related to paediatric nurses' job satisfaction.
- H13 - Communication climate is positively related to paediatric nurses' job satisfaction.
- H14 - Corporate perspective is positively related to paediatric nurses' job satisfaction.

*Looking for a new job*

- H15 - Highest level of education, years of experience, age, position and working area (controls) are negatively related to paediatric nurses looking for a new job.
- H16 - Communication climate is negatively related to paediatric nurses looking for a new job.
- H17 - Horizontal communication is negatively related to paediatric nurses looking for a new job.
- H18 - Media quality is negatively related to paediatric nurses looking for a new job.
- H19 - Organisational communication is negatively related to paediatric nurses looking for a job.
- H20 - Supervisor relationship is negatively related to paediatric nurses' looking for a new job.
- H21 - Corporate perspective is negatively related to paediatric nurses' looking for a new job.



These directional hypotheses were developed to address the hypothesised relationship between paediatric nurses job satisfaction, intention to stay and looking for another job based on previous literature. See Figure 3.

H22 - The more satisfied paediatric nurses are with organisational communication, the less likely they are to be looking for another job.

H23 - The more satisfied paediatric nurses are in their job, the less likely they are to leave their job, and the less likely they are to be looking for a new job.

#### *Interaction hypothesis*

The following hypotheses were created to test the interaction effect between the moderator (m variable), independent (x variable) and dependent variable (y variable). An interaction effect is identified when the size and direction of the independent variable changes significantly at different moderator values. Both categorical and continuous variables can be used in an interaction model (Mehmetoglu & Jakobsen, 2017). See Figure 4 for interaction effect diagram.

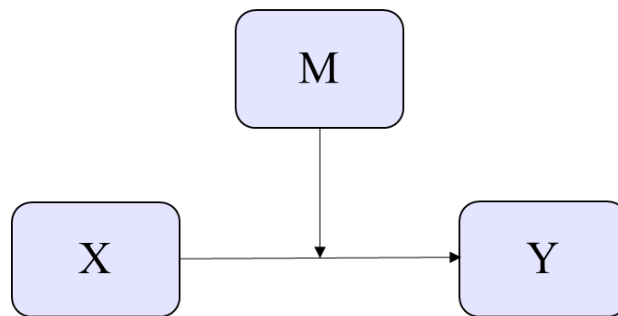

**Figure 4: Interaction effect diagram**

H24 - Years in position strengthens the positive relationships between horizontal communication and job satisfaction.

H25 - Age strengthens the positive relationship between horizontal communication and job satisfaction.

H26 - Job position dampens the positive relationship between organisational communication and job satisfaction.

## **DATA COLLECTION TECHNIQUES**

Data for the study was collected using quantitative techniques through the use of surveys. The major advantages of using this method of data collection are the quick and generally inexpensive means of obtaining a large amount of data, the administration of

questions is less time consuming and respondents can remain anonymous which may increase the honesty of responses (Nieswiadomy, 2012). However, there are some disadvantages of using this method. These include, frequent low response rates, respondents may fail to respond to the questions or may respond using socially acceptable answers; there is also a lack of opportunity for participants to clarify their understanding of items (Nieswiadomy, 2012). In order to overcome these disadvantages an information letter was provided that may have motivated respondents to participate. The questionnaire completion time was kept to a minimum to make completion less time consuming. The time that it took to complete the surveys for this study was approximately 15 minutes. Neatness and clarity of the surveys were also maintained to allow for easy understanding. All of the participants were provided with contact details of the researcher to allow for clarification of issues when needed. In addition, an email reminder about the study was sent out in week four to encourage staff completion. The surveys used in this study measured participant demographics, communication satisfaction, job satisfaction and intention to stay.

## **SAMPLING FRAMEWORK**

The unit of analysis for the study was paediatric nurses, including both RN and EN designations, and middle (nursing) managers working within the only tertiary paediatric hospital in Western Australia. The hospital is a 220 bed facility that offers general, surgical, critical care, emergency, renal, oncology, respiratory, gastroenterology, burns, mental health and outpatients care to children and adolescents, with over 250,000 children visiting per year (Government of Western Australia, n.d). The inclusion criteria for potential participants were paediatric nurses and middle managers working in a tertiary paediatric hospital. Excluded from participation were paediatric nurses and middle managers looking after adolescents in an offsite facility and paediatric nurses looking after neonates.

### **Sampling approach**

Convenience sampling was used for the distribution of the surveys. This type of sampling is a non-probability sampling method technique that allows researchers to select conveniently available participants in a timely and inexpensive manner (Polit & Beck, 2013). Sampling in this way provides no external, objective method for assessing the typicalness of the participants. Therefore, results cannot be generalised to larger populations. However, transferability of the results may be applicable. Transferability

refers to the extent to which findings from the data can be transferred to other settings or groups. A researcher needs to provide a rich and thorough description of the research setting, transactions and processes observed during the study (Lincoln & Guba, 1985) to allow readers to make a determination about the transferability of study findings to another context. Another issue with this type of sampling method is the risk of sampling bias (Gravetter & Forzano, 2016). Gravetter and Forzano (2016) explain that sampling bias caused by using convenience sampling can be overcome by two methods. Method one is to collect a broad cross section of the sample with participants from different ages, gender and different levels of education to name a few. The second method is to provide a clear description of the participants, how the sample was collected, and who the participants are. In order to overcome sample bias, the surveys were distributed to all paediatric nurses and middle managers working at the hospital. This included paediatric nurses with different levels of education, ages, years of experience, area of work and different positions. Unfortunately, gender is one area that cannot be equally represented in this sample as nursing is a female dominant profession, with only 10% of nurse working in Australia being male (Australian Bureau of Statistics, 2013). To further overcome sample bias, a thorough description of the participants is provided in Chapter 4.

#### *Sample size*

Due to the complexity of the theoretical model and level of analysis needed to investigate the relationship between variables, an SEM analysis technique was required for this study. Structural Equation Modelling will be discussed in greater detail later in this chapter. Identifying the number of participants that were needed for the SEM was dependent upon the size of the model, the distribution and reliability of the measured variables, the amount of missing data and on the strengths of the relationships between the variables (Muthen & Muthen, 2002). In general, sample size for SEM are conflicting and not very well established (Muthen & Muthen, 2002; Weston, Gore, Chan, & Catalano, 2008). However, Kline (2011), and Weston and colleagues (2008), recommend a sample size of 200 participants to ensure that the power was high enough to measure an effect in the model. Weston and colleagues (2008), went further to advocate that 10-20 participants per indicator reduces the likelihood of insufficient statistical power.

The theoretical model required 47 indicators (see Table 7) to accurately measure the constructs, which would require a minimum of 470 participants for the study. As the

population of paediatric nurses at the study hospital is 700, a 67% response rate would be needed for the study. Due to the expected response rate for questionnaire completion in nursing to be between 42%-53% (Aiken et al., 2002) a decision was made to use each latent variable as one indicator consisting of a “parcelled” set of items (Bandalos, 2002). Parcelling involves summarising or averaging a set of item scores so that a parcel score can be used in place of an item score in the SEM (Bandalos, 2002). In this study a mean of each item score was used as an indicator for each latent variable in the hypothesised conceptual model, thereby replacing individual indicators or item scores. Given that each of the nine constructs in the hypothesised model required a parcelled indicator; a sample size of between 90-180 participants were needed based on the recommendation of 10-20 participants per indicator.

Considering the relatively low response rate of questionnaire completion in nursing of 42% and 53% (Aiken et al., 2002), between 215 and 430 surveys would need to be distributed as a minimum to achieve a sample size of 90-180 participants. This was achieved by distributing a total of 390 questionnaires. This was achieved by distributing 200 information sheets with the Qualtrics™ hyperlink included (that enabled participants to complete the survey online). Each staff member had provided a personal email address to their line managers. Therefore, an email was sent to each ward manager for them to distribute to the staff working under them. This was deemed the best way to contact staff according to the industry guidance sought in the design of the study. An additional 190 printed surveys were made available throughout the hospital to enable those who preferred to complete a ‘hard copy’ than to fill in an online form.

**Table 7: Number of indicators for latent variables-non-parcelled**

<b>Group</b>	<b>Latent Variable</b>	<b>Number of Indicators</b>
Communication satisfaction	Communication climate	5
	Media quality	5
	Supervisor relationships	5
	Corporate perspective	5
	Organisational integration	5
	Horizontal communication	5
	Outcomes	
	Job satisfaction	15
	Intention to leave and looking for another job	2
<b>Total</b>		<b>47</b>

## **SURVEYS**

The survey tool incorporated a demographic questionnaire that included non-identifying employment characteristics such as, gender, age, education credentials, length and type of employment and speciality. Communication satisfaction was also measured using the survey developed by Downs and Hazen (1977). The psychometric properties of the communication satisfaction questionnaire have been re-examined more recently in the Australian retail context by Gray and Laidlaw (2004). The authors encouraged the instrument to be used for empirical and diagnostic purposes to ultimately improve organisational communication. This survey measures the relationship between communication and job satisfaction through the following eight dimensions:

- 1) Communication Climate
- 2) Relationship to Superiors
- 3) Organisational Integration
- 4) Media Quality
- 5) Horizontal and Informal Communication
- 6) Organisational Perspective
- 7) Relationship with Subordinates
- 8) Personal Feedback (Downs & Hazen, 1977)

For this study, relationships with subordinates, personal feedback and the three questions for job satisfaction were not measured, as these dimensions did not relate to the aims and objectives of the study. Instead job satisfaction was measured using the validated subsection of the work attitude survey created by Warr, Cook and Wall (1979). This tool originally had a seven-point Likert scale with 15 items, however recently the scale has been validated in nursing using a five-point Likert type scale (1 = very dissatisfied, 5 = very satisfied) with 15 items (Lu, While, & Barriball, 2007). The five-point type Likert scale was used in this study to measure job satisfaction among paediatric nurses as it was previously validated in the nursing profession. Intention to stay was measured using a subsection of the nurse survey which asked paediatric nurses' if they were planning to leave their present job, if they were actively looking for another job in nursing and if they were looking for another job how easy or difficult do they think it would be to find an acceptable job in nursing (O'Brien-Pallas et al., 2003).

## **RELIABILITY**

The surveys used in this study have established reliability. The communication satisfaction questionnaire has a reported test-retest reliability coefficient of .94 in business (Downs & Hazen, 1977). Coefficient alpha reliabilities for the eight dimensions of the communication satisfaction questionnaire have been consistently high for business, ranging from .72 to .96 for studies in the United States (Potvin, 1992) and Australia (Downs, 1991). Gray and Laidlaw (2004) identified high internal consistencies in the retail sector with all factors having a Cronbach's alpha coefficient above 0.8. Communication Satisfaction Questionnaire factors have been found to be highly correlated with job satisfaction (Downs & Hazen, 1977), strong predictors of organisational commitment (Downs, 1991; Potvin, 1992), and related to turnover (Gregson, 1987) and need fulfilment (Kio, 1980). In nursing specifically, Pincus (1986) identified a Cronbach's alpha between .67-.92 with a median 0.80. Likewise, Naz and Gul (2014), identified a Cronbach's alpha of 0.93.

The Cronbach's alpha for the five-point Likert scale of job satisfaction in a study conducted by Lu, White and Barriball (2007) was 0.89. The inter-rater reliability for all measures of the nurse survey remained at 90% during the orientation and throughout the study (O'Brien-Pallas et al., 2003). A Cronbach's alpha was recalculated for the constructs of the communication satisfaction questionnaire and job satisfaction questionnaire for this study. All constructs had acceptable Cronbach's alpha measures. These results are presented in Chapter 4.

## **DATA COLLECTION PROCEDURES**

Before the surveys were distributed a brief introduction and permission to access the wards at the hospital were sought from each unit manager. The surveys were distributed both online and via hard copy based on industry guidance. The completed hard copy surveys were placed into sealed envelopes by the completing nurses. Ward managers and Clinical Development Nurses (CDN) developed their own technique for storing the sealed envelopes with the completed surveys in from sealed boxes to large sealed envelopes. Each week for eight weeks, between April and June 2015, boxes and envelopes were checked for completed surveys. At week four, an email reminder about the study was sent out to unit managers and CDNs for distribution to ward staff. After eight weeks, no further surveys were completed both online and via hard copy, at which point the data collection ceased for the study.

## **DATA PREPARATION AND SCREENING**

Upon completion of the data collection, the online questionnaires in Qualtrics™ were downloaded into SPSS 23.0® software program. All hard copies of the surveys were manually entered into SPSS®. Data was also exported into the software package AMOS or Analysis of Moment Structures 23.0® to test the hypothesised structural model. Following entry of data into SPSS® the data was prepared and screened for missing data, univariate and multivariate outliers, distribution normality and linearity and multicollinearity.

### **Type of collected data**

The data collected from the surveys included demographic information, organisational communication satisfaction, job satisfaction and intention to stay. The demographics information; highest level of education, age, number of year in position and position were ordinal scales. Gender and what area they worked in and job status were nominal scales. The communication satisfaction and job satisfaction surveys were ordinal measures asking paediatric nurses and middle managers to rate their perceptions from extremely satisfied to extremely dissatisfied. Intention to stay was measured by three questions. The questions “if you were looking for another job how easy or difficult do you think it would be to find an acceptable job in nursing” and “are you actively looking for another job in nursing”, were nominal scales and the question are you planning to leave your present job was a nominal scale.

### **Missing data**

The amount of missing data was examined in order to prevent bias in standard error, parameter estimates and test statistics (Allison, 2003). The data was screened for missing responses. Due to the risk of nonresponse bias participants with more than 10% missing responses were removed in their entirety from the data set and not included in the analysis (Kline, 2011). For participants with less than 10% missing data, Full Information Maximum Likelihood estimation was used as it produces the least bias in the missing values (Ender & Bandalos, 2001). The data was also checked for unengaged responses resulting in no variance in the response to each question. Participants who are unengaged tend to speed through a survey, straight lining the answers in matrix questions and provide inconsistent or random responses (Suresh, 2011). Participants were removed if the standard deviation (SD) of responses equalled zero, or had very

little deviation in responses, as this results in little variation in responses and poor quality of data (Suresh, 2011). The results of the missing data analysis will be presented in Chapter 4.

## **Outliers**

Extreme values in data can artificially inflate the chi-squared value of a model, which results in false rejection of models as well as underestimation with error of parameter (Kline, 2011). As a way to counter these extreme values in the data, a z score was made for each variable. The absolute z score of  $\pm 3.29$  was used to identify outliers (Boltynkov, 2015) and will be presented in Chapter 4.

The Mahalanobis distance ( $D^2$ ) test was computed in AMOS<sup>®</sup> to determine the presence of multivariate outliers. Mahalanobis distance ( $D^2$ ) refers to the distance in terms of standard deviation for a set of scores for an individual case (vector), and the sample mean of all variables in the data set (centroids). A multivariate outlier will have a distinctive  $D^2$  to all other cases (Kline, 2011). AMOS<sup>®</sup> also provides a P1 and a P2 value. P1 refers to the probability of a score exceeding the squared Mahalanobis distance of a specific case and is expected to have a small value. The P2 score is the probability of the largest squared distance of any score would be greater than  $D^2$ . Assuming the data is normally distributed a large  $D^2$  value and small P2 values indicates the score is far from the centroid and most likely an outlier in the data (Kline, 2011). The Mahalanobis distance was calculated by using AMOS<sup>®</sup> during the analysis of the model. The results of the analysis were searched for a high  $D^2$  value and a P2 of less than .001 to signify an outlier. No cases were found to be outliers in the data.

## **Distribution normality**

Skewness and kurtosis of study variables were examined to identify if the data distribution was normal (Kline, 2011). Normality of the data is assumed when the absolute values of skewness index is less than  $\pm 3$  and kurtosis values less than  $\pm 10$  (Kline, 2011). The skewness value for the items ranged from -1.809 to 1.063. The kurtosis values ranged from -1.339 to 2.368. Gender again was the only variable to have kurtosis issues with a value of 12.618. A bell curve for each variable is presented in the Appendix A.



## Linearity

For Structural Equation Modelling to be used as an analysis technique, the constructs of the organisational communication satisfaction questionnaire and job satisfaction needed to be sufficiently linear (Kline, 2011). Curve estimation was calculated for the relationships between the six constructs of organisational communication satisfaction survey and job satisfaction as shown in the models in Figure 5.

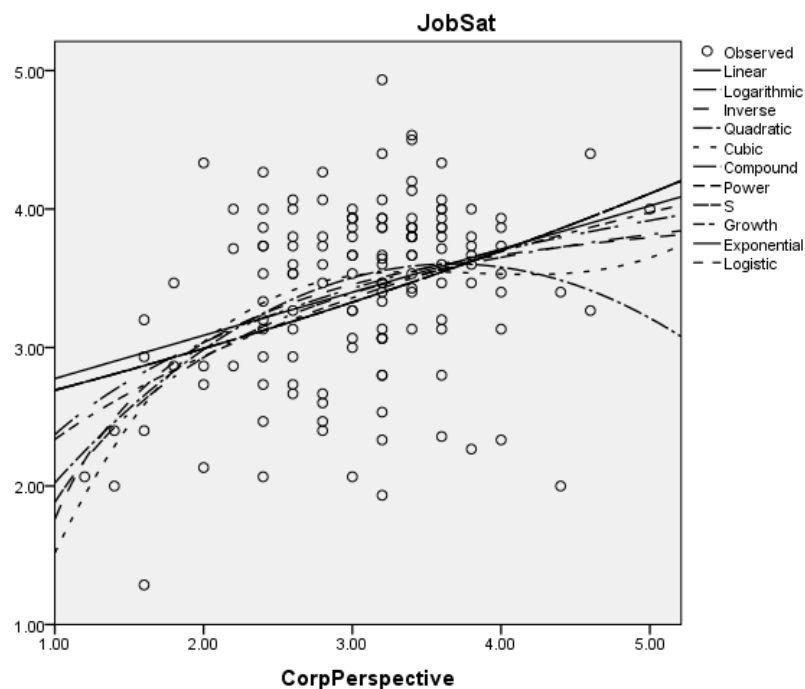
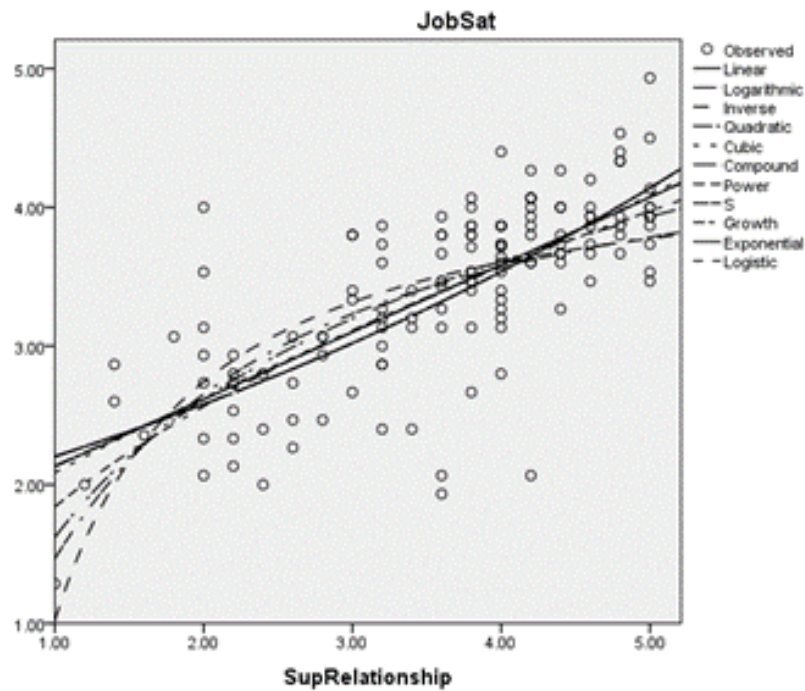

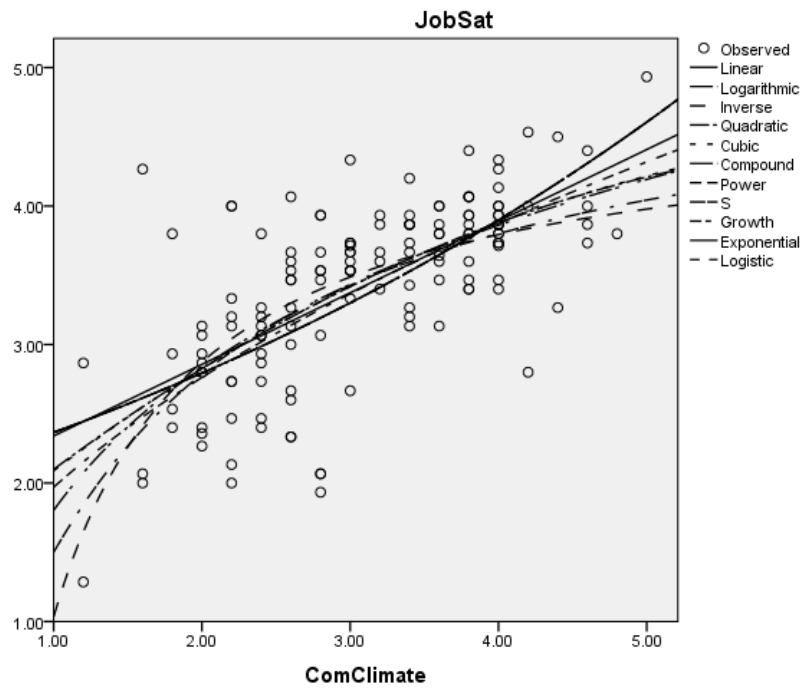
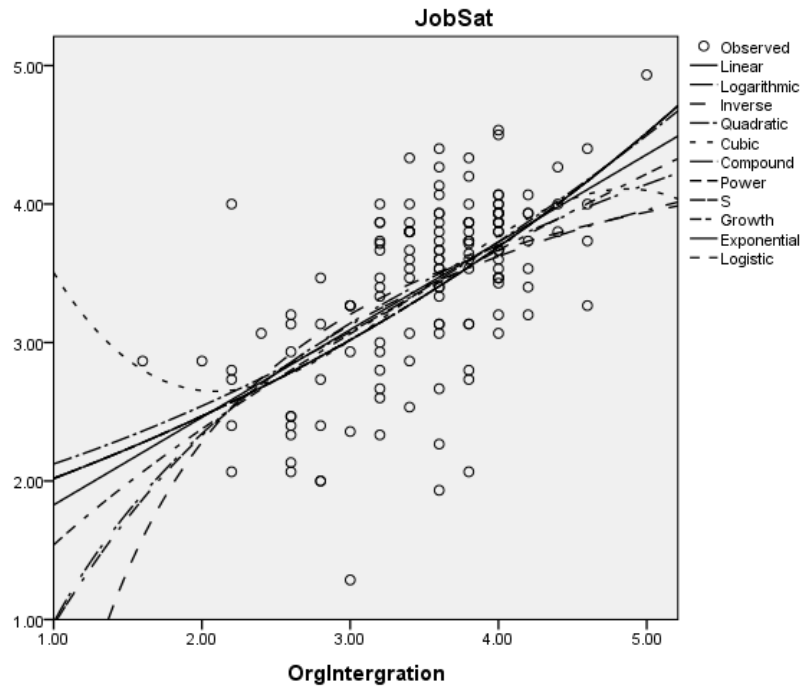

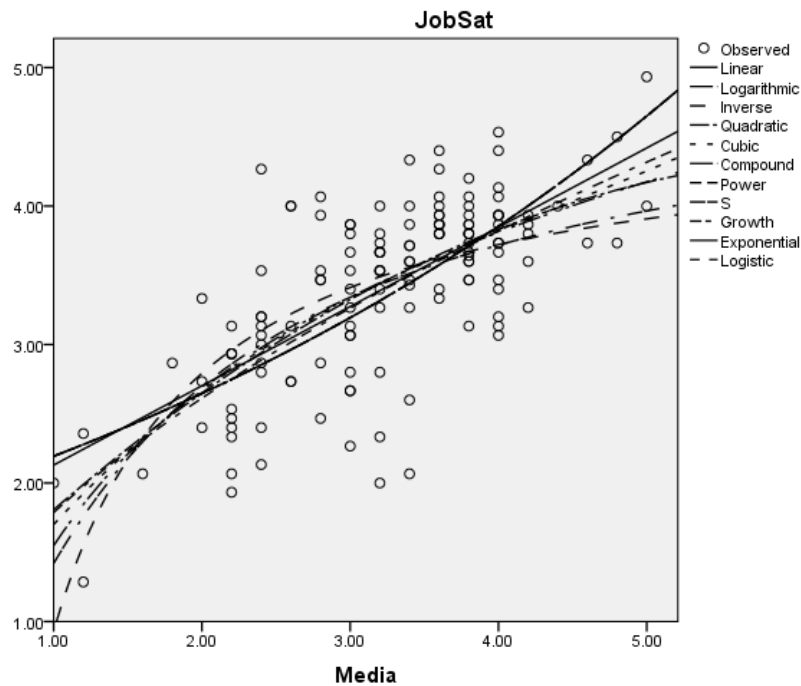

**Figure 5: Linearity of relationships between organisational communication satisfaction and job satisfaction**

It was determined that all relationships between the six constructs of the organisational communication satisfaction questionnaire and job satisfaction were sufficiently linear to be tested in a covariance based SEM such as that used in AMOS®.

### **Multicollinearity**

In Structural Equation Modelling, multicollinearity issues leads to inaccurate coefficient estimates and standard error, as well as inference errors (Mason & Perreault, 1991). In order to prevent these, correlations among study variables were calculated to identify multicollinearity. Correlation coefficients of below .20 are considered to have a very weak or non-existent correlation. Values between .20 and .40 are considered to be weak. Values between .40 and .70 are moderately strong. Values between .70 and .85 are considered to be highly correlated and values above .85 are considered to be very high (Munro, 2005). The results of the correlation are presented in Chapter 4.

## **DATA ANALYSIS TECHNIQUES**

Following data preparation and screening, several statistical techniques were utilised to answer the research questions. Descriptive statistics were used for participant demographics and presented in terms of standard deviations, numbers and percentages. Mann-Whitney U Test was used to assess the difference in each item in the

communication satisfaction questionnaire between middle managers and paediatric nurses. This technique was used to identify any disconnect between the two groups perception of communication satisfaction. The descriptive analysis and the Mann Whitney U test allowed for the second aim of the study to be assessed, identifying any difference in organisational communication satisfaction between paediatric nurses and middle managers, different educational experience, years of nursing and managerial experience, contracted hours, area of work, age and gender. The data package SPSS 23.0<sup>®</sup> was used for this component of the analysis. The first aim of the study, was to investigate paediatric nurses' and middle managers' satisfaction with organisational communication and the effect this has on paediatric nurses' job satisfaction and intention to stay in their current job. The first aim of the study was analysed using Congenic Factor Analysis, which measures the relationships between items and a common construct (Christenson, Reschly, & Wylie, 2012), Confirmatory Factor Analysis (CFA), which measures the factor structure of a set of observed variables (Munro, 2005) and Structural Equation Modelling (SEM). This was considered the most appropriate techniques to use due to the complexity of the model, to identify relationships between the communication satisfaction subscales, job satisfaction and intention to stay. The data package AMOS 23.0<sup>®</sup> was used for the Congeneric Factor Analysis, CFA and SEM.

### **Measurement model**

Following data preparation and descriptive analysis the constructs of the communication satisfaction questionnaire underwent Congenic Factor Analysis. The congeneric measurement theory is used to measure the relationships between items and a common construct. A congeneric model can be evaluated within the context of a Confirmatory Factor Analysis (CFA)(Christenson, Reschly, & Wylie, 2012).

#### *Confirmatory Factor Analysis*

CFA is a special application of SEM used to measure the factor structure of a set of observed variables (Munro, 2005). The CFA was carried out for the communication satisfaction questionnaire following items undergoing Congenic Factor Analysis. The 15 items of the job satisfaction questionnaire were all considered to contribute to one's job satisfaction. Therefore, job satisfaction did not undergo CFA and instead was calculated as a mean score.

### *Model fit*

Several fit indices were used to report and interpret the goodness of fit between the hypothesised model and the observed data (Kline, 2011) in the CFA and SEM. These specific indices were chosen as they have been found to be the most accurate reflection of model fit (Kline, 2011). The Chi-squared ( $\chi^2$ ) was used to assess the discrepancy between the covariance matrix and the hypothesised model. A non-significant value less than .05 was used as evidence of a good fit (Kline, 2011). Due to the challenges in achieving a non-significant chi-square value (Kline, 2011), model fit was also determined by using the Standardised Root Mean Square Residual (SRMR), Comparative Fit Index (CFI), Root Mean Square Error of Approximation (RMSEA) and pCLOSE. SRMR refers to the average discrepancy between the observed and hypothesised correlation matrices. A SRMR value of less than .08 was desirable. The CFI represents the comparison between the null hypothesis and the hypothesised model. A value greater than .95 is desirable for this measure. The RMSEA measures the error in the population and is reported as a 90% confidence interval. The RMSEA is considered to be one of the most important values in SEM (Byrne, 2016) with a desired value of .05 (Kline, 2011). The pCLOSE represents the p value of the hypothesis and has a desired value of greater than .05 (Byrne, 2016). These values, presented in Table 8, were used in the CFA as a measure of goodness of fit.

***Table 8: Goodness of fit indices used for the SEM***

<b>Model Fit Indices</b>	<b>Desirable Value</b>
Chi-square ( $\chi^2$ )	<.05
Standardised Root Mean Square Residual (SRMR)	<.05
Comparative Fit Index (CFI)	>.95
Root Mean Square Error of Approximation (RMSEA)	<.05
pCLOSE	>.05

In addition, Measurement error covariances or Modification indices were also used (MI) to adjust the models. Modification Indices provide evidence of model misspecification and arise from the items cross-loading on an omitted construct or content overlap with another item (Byrne, 2016). Items were removed in order from highest to lowest MI with each model reanalysed after an item was removed. Included in the MI parameter is the Par Change or the parameter change statistic, which

represents the predicted estimated change in the new path coefficient (Byrne, 2016; Kline, 2011).

## **STRUCTURAL EQUATION MODELLING**

Structural Equation Modelling (SEM) was chosen for the analysis of data in this study as it has numerous benefits and advantages when compared with other analytic techniques. In the first instance, SEM is a multivariate technique that allows for testing and revision of a hypothesised model. Both direct and indirect relationships between constructs can be tested simultaneously, unlike other analytic techniques that examine only individual effects represented in a model (Kline, 2011). This allowed for a higher level of analysis to be conducted and a greater understanding of the study's hypothesised model to be gained (Kline, 2011). Additionally, SEM allowed for CFA to be carried out, which allows for confirmation of the validity of each measurement model. Furthermore, SEM controls errors within the model by depicting the error between the indicators and the latent variables (Weston et al., 2008). Figure 2 illustrates the hypothesised SEM of paediatric nurses' communication satisfaction and its effects on job satisfaction and intention to leave. The participant demographics; age, highest level of education, years of experience, position and working area were used as control within the hypothesised model. Figure 3 presents the hypothesised SEM of paediatric nurses' job satisfaction, and its effects on intention to leave one's job and the nursing profession and looking for another job. The participant demographics of age, position and years in current position were used as controls in the hypothesised model.

## **ETHICAL CONSIDERATIONS**

Permission to undertake this study was sought from Edith Cowan University Human Research Ethics Committee and from the Hospital's Human Research Ethics Committee. Participants were presented with an information sheet outlining the purpose of this study. Participation was voluntary and participants had the right to withdraw from the study at any time without prejudice or a need for justifying the decision. As the surveys were anonymous, any submitted data will not be able to be returned to the participants as it was de-identified. A formal consent was signed by each participant either online before completion of the surveys in Qualtrics™, or by hard copy from the researcher if the survey was completed one-on-one with participants. Each participant was given a copy of the information sheet, which had the contact details of the researcher, along with the details for Edith Cowan University Human Research Ethics

Committee and the Hospital's Human Research Ethics Committee, in case the participants had further questions or complaints. Should the participants become distressed during the study they were advised and encouraged to withdraw from the study with support offered to them by the researcher and counselling services. The Samaritans Crisis line accepted to help and support participants that become emotionally distressed during or at the completion of the study. They could be contacted 24 hours a day via phone on 13 52 47 or via email on [admin@samaritanscrisisline.org.au](mailto:admin@samaritanscrisisline.org.au).

The data has been stored according to NHMRC guidelines (National Health and Medical Research Council, 2015) on a password protected computer with access only permitted to the researcher. The data will be stored in a secure place for five years, after which time it will be destroyed in a safe and secure manner. Confidentiality and anonymity were maintained throughout. Any information resulting from this study did not identify any participants. The results of this study were presented in the form of a written report to the study site and Edith Cowan University.

## **SUMMARY**

This chapter introduced the methods and materials that were used to answer the research questions and achieve the desirable outcomes. Included in this chapter were the study design, theoretical model, data collection, analysis, sampling, validity and reliability. This chapter also reviewed the ethics and standards that were maintained and study limitations experienced in the study. Chapter 4 will discuss the demographic and contextual results from the study.

---

# CHAPTER 4: DEMOGRAPHIC AND CONTEXTUAL RESULTS

## INTRODUCTION

This chapter will present the demographic and contextual findings from the study. The study involved the distribution and analysis of surveys to investigate paediatric nurses' and middle managers' satisfaction with organisational communication and the effect this has on paediatric nurses' job satisfaction and intention to leave their current job and looking for another job. First, the survey response rate of the surveys will be examined with a description of the data collection time line provided. Demographic information of the participants and working characteristics are then discussed, followed by data planning and screening for multicollinearity and outliers. Secondly, the results from a Mann-Whitney U Test will be assessed to identify differences in communication satisfaction between paediatric nurses and middle managers. Thirdly, organisational communication satisfaction will be assessed between paediatric nurses and middle managers with different educational levels, years of nursing and managerial experience, contracted hours, area of work, age and gender, to identify areas of dissonance. Structural Equation Modelling of the data is provided in Chapter 5.

## SURVEY RESPONSE RATE

Of the 200 surveys and 190 information sheets with the online link distributed, a total of 165 surveys were completed both online and in hard copy, for a response rate of 42.4%. This is in keeping with the expected response rate of questionnaire completion in nursing of 42%-53% (Aiken, Clarke, & Sloane, 2002). Eight participants had more than 10% of missing responses and were subsequently removed using Listwise deletion (Kline, 2011). These responses were considered to be missing completely at random due to the likelihood of paediatric nurses and middle managers commencing the questionnaire and not having time to complete in one sitting. Unfortunately, in this study once you exited from the Qualtrics™ program you could not return to complete the questionnaire at a later date or time without starting the survey from the beginning. This reduced the number of participants to 157. The remainder of the data was screened for participants with less than 10% missing data. There was one participant with one



response missing. Full information maximum likelihood estimation was carried out using mean substitution (Kline, 2011). Mean substitution was used where the overall sample mean was used to replace the missing data (Kline, 2011). Given that there was less than 5% missing data, mean substitution was considered an appropriate approach for management. The data was also checked for unengaged responses. Participants were removed if the standard deviation (SD) of responses equalled zero or if the standard deviation was below 0.05. Three participants were removed due to low SD (Suresh, 2011). The resulting sample size was 154 participants or 93% of received responses being usable, which is well within the required sample size of 90-180 (see Chapter 3).

## **RESPONSE BIAS**

Non-response bias relates to variation in relevant survey characteristics between respondents and non-respondents. Differences between these two groups could result in possible measurement errors (Lambert & Harrington, 1990).

For this study, non-response bias was tested using the classic method, which assumes that reluctant responses are similar to non-responses. The characteristics of reluctant participants are then used to estimate the impact of non-participation on study outcomes (Curtin, Presser, & Singer, 2000; Lin & Schaeffer, 1995; Montaquila, Brick, Hagedorn, Kennedy, & Keeter, 2008; O'Neil, 1979; Smith, 1984; Stinchcombe, Jones, & Sheatsley, 1981).

In this study, response bias was examined by using a 'before' and 'after' response category. The 'before' category referred to participants who responded promptly to completing the surveys without any encouragement. The 'after' category applied to participants who responded after the email reminder was sent. Table 9 contains the distribution of the responses.

***Table 9: Before group and after group distribution of responses***

	<b>Frequency (N)</b>	<b>Percent (%)</b>
Before group	108	70.0
After group	46	30
<b>Total</b>	<b>154</b>	<b>100.0</b>

The 'before' group, those who responded after the initial distribution of the surveys, comprised of 70.0 % of the sample. Thirty per cent of the sample were categorised as the 'after' group as they responded after the email reminder was sent out. In total, there were 154 responses, 108 before cases and 46 after cases.

A one-way analysis of variance (ANOVA) was applied to investigate the possibility of organisational communication survey non-response bias. The comparative analysis was performed on 35 items of the organisational communication instrument to determine if there were any significant differences between responses in the 'before' and 'after' groups. Table 10 shows a summary of the ANOVA results for the 'before' and 'after' groups for the organisational communication satisfaction survey.

**Table 10: ANOVA results for before and after groups for the organisational communication satisfaction survey**

	<b>F</b>	<b>P Value</b>
Information about my progress in my job	2.748	.099
Personal news	1.205	.274
Information about benefits and pay	.001	.978
Information about the requirements of my job	.042	.837
Information about departmental policies and goals	.089	.766
information about organisational policies and goals	.903	.344
Information about changes in our organisation	.004	.952
Information about government action affecting my organisation	.408	.524
Information about our organisation's financial standing	.718	.398
Information about accomplishments and/or failures of the organisation	.043	.837
Extent to which my supervisor listens and pays attention to me	3.448	.065
Extent to which my supervisor offers guidance for solving job related problems	3.178	.077
Extent to which my supervisor trusts me	1.418	.236
Extent to which the amount of supervision given me is about right	1.494	.233
Extent to which my supervisor is open to ideas	1.225	.270
Extent to which the people in my organisation have great ability as communicators	1.229	.269
Extent to which I receive, in time, the information needed to do my job	2.787	.097
Extent to which conflicts are handled appropriately through proper communication channels	.059	.809
Extent to which the organisation's communication make me identify with or feel a vital part of it	.944	.333
Extent to which the organisation's communication motivates and stimulates an enthusiasm for meeting its goals	3.842	.052

Extent to which horizontal (peers, CN-CN, RN-RN) communication with other organisational members is accurate and free flowing	.937	.335
Extent to which communication practices are adaptable to emergencies	.058	.809
Extent to which my work group is compatible	.677	.412
Extent to which informal communication is accurate and active (Informal communication refers to social relationships)	.384	.537
Extent to which the grapevine is active in our organisation	.017	.897
Extent to which written directives and reports are clear and concise	1.987	1.61
Extent to which the attitudes toward communication in the organisation are basically healthy	.828	.364
Extent to which our meetings are well organised	.006	.940
Extent to which the amount of communication in the organisation is about right	.013	.911
Extent to which the organisation's communication are interesting and helpful	.189	.664

The analysis did not show any significant differences in responses made by the 'before' and 'after' respondents on all 35 items. These results confirm that non-response bias was not an issue for the organisational communication satisfaction survey.

## **SAMPLE DEMOGRAPHICS**

Descriptive statistics were completed using the SPSS 23.0<sup>®</sup> software package to summarise demographic characteristics of the participants. These characteristics included: position, gender, participant age, level of education, current employment status, area of work, and how many years they had been employed in their current role.

### **Participant's position**

Among the 154 participants, the majority of paediatric nurses (45.5%) were registered nurses with the smallest number of participants being clinical nurse managers (5.2%). The "other" which made up 9.7% of the total population, consisted of clinical nurse specialists (5.2%), clinical nurse consultants (.6%), management (.6%), nurse educators (1.3%) and senior registered nurses (2%). Table 11 contains a summary of participants nursing position.

*Table 11: Summary of participant position*

<b>Position</b>	<b>EN</b>	<b>RN</b>	<b>CN</b>	<b>SDN</b>	<b>CNM</b>	<b>Other</b>	<b>Total</b>
Frequency (N)	10	70	37	14	8	15	154
Percent (%)	6.5	45.5	24.0	9.1	5.2	9.7	100

In order to answer the research questions and outcomes of the study the participants were grouped into two groups according to their position at the hospital. The two groups were coded into ward nurses and middle managers. The ward nurse group consisted of paediatric nurses in the following positions: enrolled nurses (EN), registered nurses (RN), clinical nurses (CN) and clinical development nurses (CDN) or staff development nurses (SDN). The middle managers group consisted of clinical nurse managers (CNM), senior registered nurses (SRN), clinical nurse specialists and clinical nurse consultants (CNC). This resulted in a sample of 131 (85.1% of the sample population) ward nurses and 23 (14.9% of the sample population) middle managers, as presented in Table 12.

### **Participant's gender**

The majority of paediatric nurses in the sample were female consisting of 94% (131) of the ward nurse group and 96% of the middle managers. Out of the males within the sample the majority (88.9%, eight participants) were a part of the ward nurse group. There was only one male in the middle managers group. Table 12 contains a summary of the participant's gender based on the two groups.

***Table 12: Participant demographics***

<b>Demographics</b>	<b>Ward Nurses %</b>	<b>Middle Managers %</b>
Participant Gender - Female	123 (94%)	22 (95%)
Participant Gender - Male	8 (6%)	1 (5%)
<b>Participant Gender Total</b>	<b>131 (100%)</b>	<b>23 (100%)</b>
Participant Age - 18-29	58 (44%)	-
Participant Age - 30-49	53 (40%)	18 (78%)
Participant Age - 50-64	19 (15%)	5 (22%)
Participant Age - 65+	1 (1%)	-
<b>Participant Age Total</b>	<b>131 (100%)</b>	<b>23 (100%)</b>
Highest Level of Education - EN	8 (6%)	-
Highest Level of Education - RN Hospital	4 (3%)	1 (4%)
Highest Level of Education - RN Post Basic	5 (4%)	-
Highest Level of Education - RN Diploma	17 (13%)	3 (13%)
Highest Level of Education - Bachelor Degree	61 (46%)	3 (13%)
Highest Level of Education - Graduate Certificate	14 (11%)	5 (22%)
Highest Level of Education - Graduate Diploma	14 (11%)	8 (35%)

Highest Level of Education - Master's Degree	8 (6%)	3 (13%)
Highest Level of Education - PhD	-	-
<b>Highest Level of Education Total</b>	<b>131 (100%)</b>	<b>23 (100%)</b>
Participant Employment Status - Full Time	80 (61%)	14 (61%)
Participant Employment Status - Part Time	46 (35%)	9 (39%)
Participant Employment Status - Casual	5 (4%)	-
<b>Participant Employment Status Total</b>	<b>131 (100%)</b>	<b>23 (100%)</b>
Area of Work - General medical and surgical	28 (21%)	6 (26%)
Area of Work - Burns	2 (2%)	-
Area of Work - Critical care services <ul style="list-style-type: none"> <li>• ICU/CCU</li> <li>• Perioperative</li> <li>• Emergency Department</li> </ul>	28 (21%)	9 (39%)
Area of Work - Day Stay	7 (6%)	-
Area of Work - Outpatients	6 (4%)	-
Area of Work - Management	-	2 (9%)
Area of Work - Other	60 (46%)	6 (26%)
<b>Area of Work Total</b>	<b>131 (100%)</b>	<b>23 (100%)</b>
Number of Years in Current Role - < 1 years	27 (21%)	1 (4%)
Number of Years in Current Role - 1-2 years	31 (24%)	4 (17%)
Number of Years in Current Role - 3-4 years	24 (18%)	7 (30%)
Number of Years in Current Role - 5-6 years	16 (12%)	-
Number of Years in Current Role - 7-8 years	13 (10%)	2 (9%)
Number of Years in Current Role - 9-10 years	4 (3%)	2 (9%)
Number of Years in Current Role - 11 + years	16 (12%)	7 (30%)
<b>Number of Years in Current Role Total</b>	<b>131 (100%)</b>	<b>23 (100%)</b>

## Participant's age

The majority of the participants in the ward nurses group were aged between 18-29 years (44.3 %, 58). There was only one ward nurse in the 65 and over category making up .76% of the ward nurse sample, 53 (40.5%) in the 30-49 age group and 19 (14.5%) in the 50-64 age group. The majority of the middle managers group were aged in the 30-49 category, comprising of 78.3% (18) of this group, with the remaining middle managers in the 50-64 age category (21.7%, 5). Table 12 contains a summary of the participant's age based on the two groups.

## **Participant's highest level of education**

In terms of nursing education, the majority of the ward nurses had a bachelor degree making up 46.6 % (61) of the ward nurses group. The highest level of education earned by the ward nurses was a master degree with 8 (6.1%) of the participants with this degree. Eight (6.1%) participants in the ward nurse group were enrolled nurses, four (3.1%) became registered nurses through hospital training, five (3.8%) had post basic education training, 17 (13%) had a registered nurse diploma education and 28 had a graduate certificate (14, 10.7%) and graduate diploma degree (14, 10.7%).

The majority of the middle managers had a graduate diploma making up 34.8% (8) of the highest education level in the middle managers group. One (4.3%) participant in the middle managers group had a highest level of education of hospital based training. Three (13%) middle managers had a registered nurse diploma, three (13%) middle managers' highest education level was that of registered nurse bachelor degree, five (21.7) had a graduate certificate and three (13%) had a master's degree. Table 12 contains a summary of the highest level of education earned by each group.

## **Participant's employment status**

The majority of participants in both the ward nurses and middle managers group worked full time consisting of 61.1% (80) and 60.9% (14) respectfully. Forty-six (35.1%) ward nurses were part time and 3.8% (5) were casual workers. Nine (39.1%) of the middle managers were employed on a part time basis. There were no middle managers employed on a casual basis in the sample. Table 12 contains a summary of the participant's employment status.

## **Participant's area of work**

The majority of participants in the ward nurse group worked in the category of 'other', which consisted of 45.8 % (60) of the group. The 'other' category consisted of oncology, hospital in the home, digital imaging, haematology, rehabilitation, ambulatory care, consumables, mental health, education, flu vaccine and plastics. The remainder of the ward nurses worked in the critical care services (28, 21.4%), surgical (16, 12.2%), general (12, 9.2%), burns (2, 1.5%), ICU/CCU (4, 3.1%), operating theatres (4, 3.1%), day stay (7, 5.3%), mental health unit (1, 0.8%), outpatients (6, 4.6%) and education (3, 2.3%).

The majority of the middle managers worked in critical care services (9, 39.1%), six worked in other wards (26.0%) six (26.0%) worked in general medical and surgical, and two (8.7%) worked in management. Table 12 contains a summary of participant's areas of work in the ward nurses and middle managers group.

### **Number of years in current role**

The majority of the ward nurses were employed in the current position for 1-2 years (31, 23.7%). Twenty-seven (20.6%) ward nurses were employed for less than one year, 24 (18.3%) employed for 3-4 years, 16 (12.2%) employed for 5-6 years, four (3.1%) employed for 9-10 years and 16 (12.2%) ward nurses employed for 11 years over.

The majority of middle managers were equally distributed between the 3-4 years and 11 years and over category consisting of seven (30.4%) participants in each. There was one (4.3%) middle manager employed for less than one year, four (17.4%) middle manager employed for 1-2 years, two (8.7%) middle managers employed for 7-8 years and two (8.7%) middle managers employed for 9-10 years. Table 12 contains a summary of participant's years in their current position.

## **COMMUNICATION SATISFACTION DIFFERENCES BASED ON LEVEL OF EDUCATION, YEARS OF NURSING AND MANAGERIAL EXPERIENCE, CONTRACTED HOURS, AREA OF WORK, AGE AND GENDER**

It was an aim of the study to assess if there is a difference in organisational communication satisfaction between paediatric nurses and middle managers with different educational levels, years of nursing and managerial experience, contracted hours, area of work, age and gender. A box graph and frequency was conducted for each which provides a summary of the distribution and presents the median, 25<sup>th</sup>, 75<sup>th</sup> percentiles and extreme scores.

### **Communication satisfaction between paediatric nurses and middle managers with different educational levels**

Communication satisfaction between paediatric nurses and middle managers with different educational levels was graphed onto a box plot (See Figure 6). None of the box plots are normally distributed with most medians either being positively skewed with the median line closer to the bottom or negatively with the median line closer to the top (Coakes & Steed, 2011). Table 13 presents the mean and median communication satisfaction values for each educational level. From the box plots and the frequency tables presented, it is apparent that paediatric nurses and managers with a master's degree and graduate certificate have lower communication satisfaction medians than paediatric nurses and managers with other educational levels.



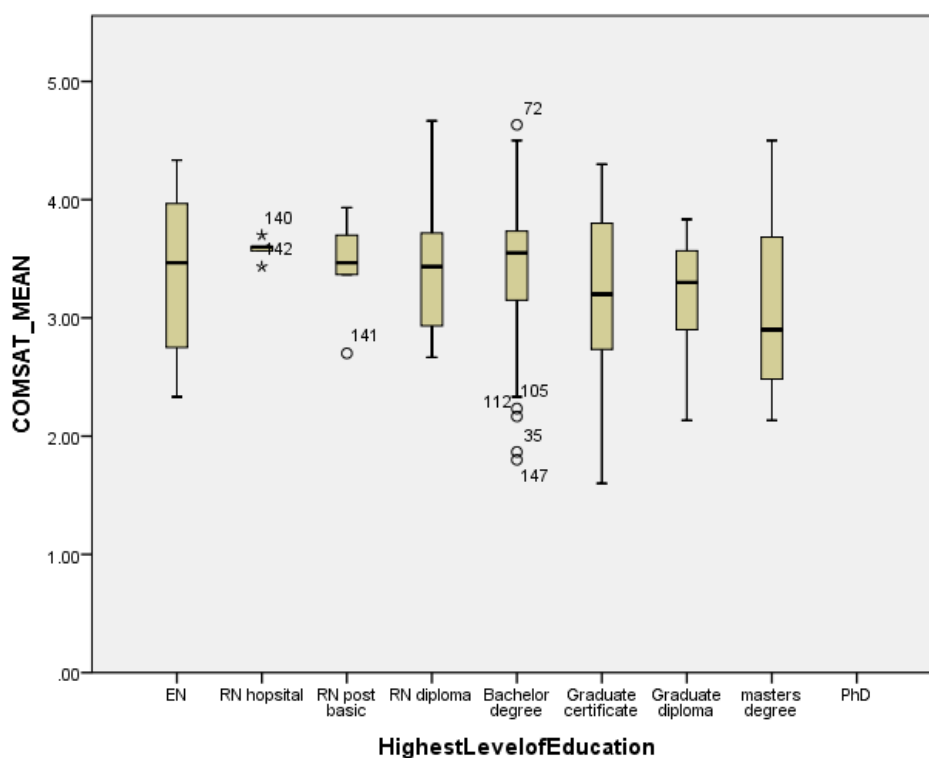

**Figure 6: Communication satisfaction between paediatric nurses and middle managers with different educational levels**

**Table 13: Mean and median communication satisfaction values for each educational level**

Mean and Median Communication Satisfaction Values for each Educational Level	Mean	Median	Number
EN	3.37	3.46	8
RN Hospital	3.58	3.60	5
RN Post Basic	3.43	3.46	5
RN Diploma	3.41	3.43	20
Bachelor Degree	3.40	3.55	64
Graduate Certificate	3.16	3.20	19
Graduate Diploma	3.20	3.30	22
Master's Degree	3.07	2.90	11
PhD	--	--	--

**Communication satisfaction between paediatric nurses and middle managers with different years of nursing and managerial experience**

Communication satisfaction between paediatric nurses and middle managers with different years of nursing and managerial experience was graphed onto a box plot (See

Figure 7). None of the box plots are normally distributed with most medians either being positively skewed with the median line closer to the bottom or negatively with the median line closer to the top (Coakes & Steed, 2011). Table 14 presents the mean and median communication satisfaction between paediatric nurses and middle managers with different years of nursing and managerial experience. From the box plots and the frequency tables presented, it is apparent that paediatric nurses and middle managers with 5-6 years and 9-10 years of nursing and managerial experience have lower median communication satisfaction values than paediatric nurses and middle managers with other levels of nursing and managerial experience.

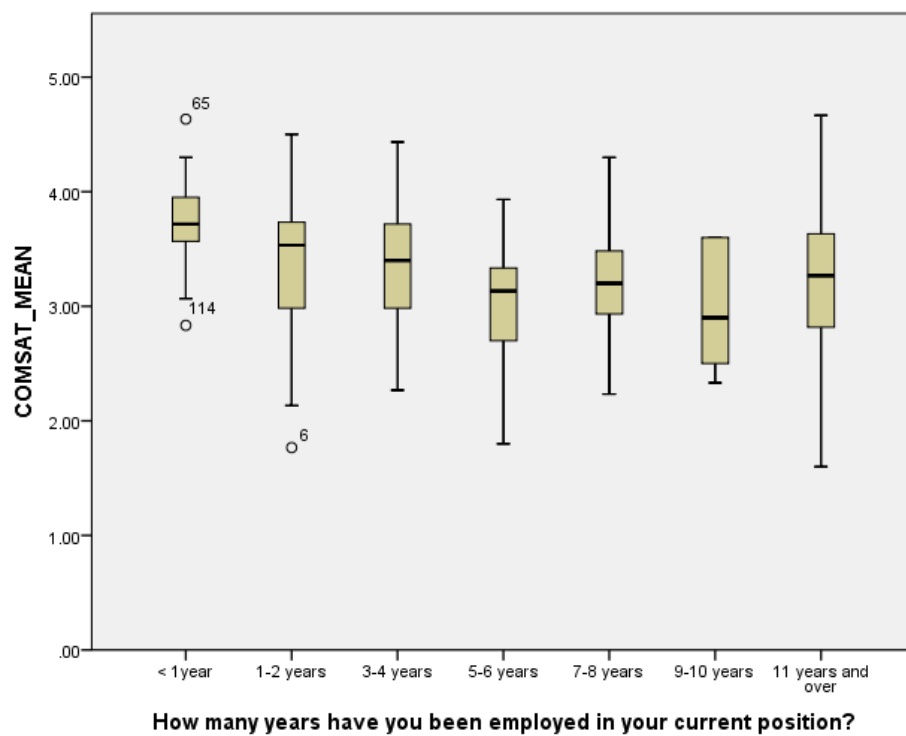

**Figure 7: Communication satisfaction between paediatric nurses and middle managers with different years of nursing and managerial experience**

**Table 14: Mean and median communication satisfaction between paediatric nurses and middle managers with different years of nursing and managerial experience**

<b>Mean and Median Communication Satisfaction Between Paediatric Nurses and Middle Managers with Different Years of Nursing and Managerial Experience</b>	<b>Mean</b>	<b>Median</b>	<b>Number</b>
< 1 years	3.70	3.71	28
1-2 years	3.36	3.53	35
3-4 years	3.36	3.40	31
5-6 years	2.97	3.13	16
7-8 years	3.21	3.20	15
9-10 years	2.97	2.90	6
11+ years	3.18	3.26	23

### **Communication satisfaction between ward nurses and middle managers with different contract hours**

Communication satisfaction between paediatric nurses and middle managers with different contract hours was graphed onto a box plot (See Figure 8). None of the box plots are normally distributed with most medians either being positively skewed with the median line closer to the bottom or negatively with the median line closer to the top (Coakes & Steed, 2011). Table 15 presents the mean and median communication satisfaction between paediatric nurses and middle managers with different contract hours. From the box plots and the frequency tables presented, it is apparent that paediatric nurses and middle managers who work part time have lower median communication satisfaction values than paediatric nurses and middle managers that work full time and casual hours.

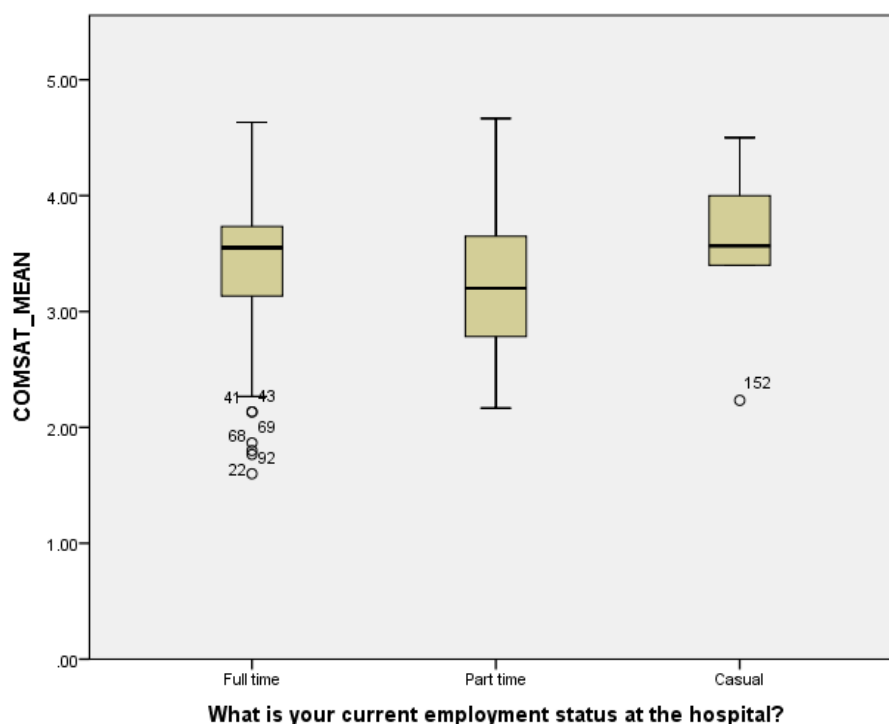

**Figure 8: Communication satisfaction between paediatric nurses and middle managers with different contracted hours**

**Table 15: Mean and median communication satisfaction between paediatric nurses and middle managers with different contract hours**

Mean and Median Communication Satisfaction Between Paediatric Nurses and Middle Managers with Different Contract Hours	Mean	Median	Number
Full Time	3.38	3.55	94
Part Time	3.21	3.20	55
Casual	3.54	3.56	5

### **Communication satisfaction between paediatric nurses and middle managers from different specialty areas**

Communication satisfaction between paediatric nurses and middle managers from different specialty areas were graphed onto a box plot (See Figure 9). None of the box plots are normally distributed with most medians either being positively skewed with the median line closer to the bottom or negatively with the median line closer to the top (Coakes & Steed, 2011). Table 16 presents the mean and median communication satisfaction between paediatric nurses and middle managers from different specialty areas. From the box plots and the frequency tables presented, it is apparent that paediatric nurses and middle managers who work in the outpatient's department have

lower median communication satisfaction values than paediatric nurses and middle managers that work in other specialty areas.

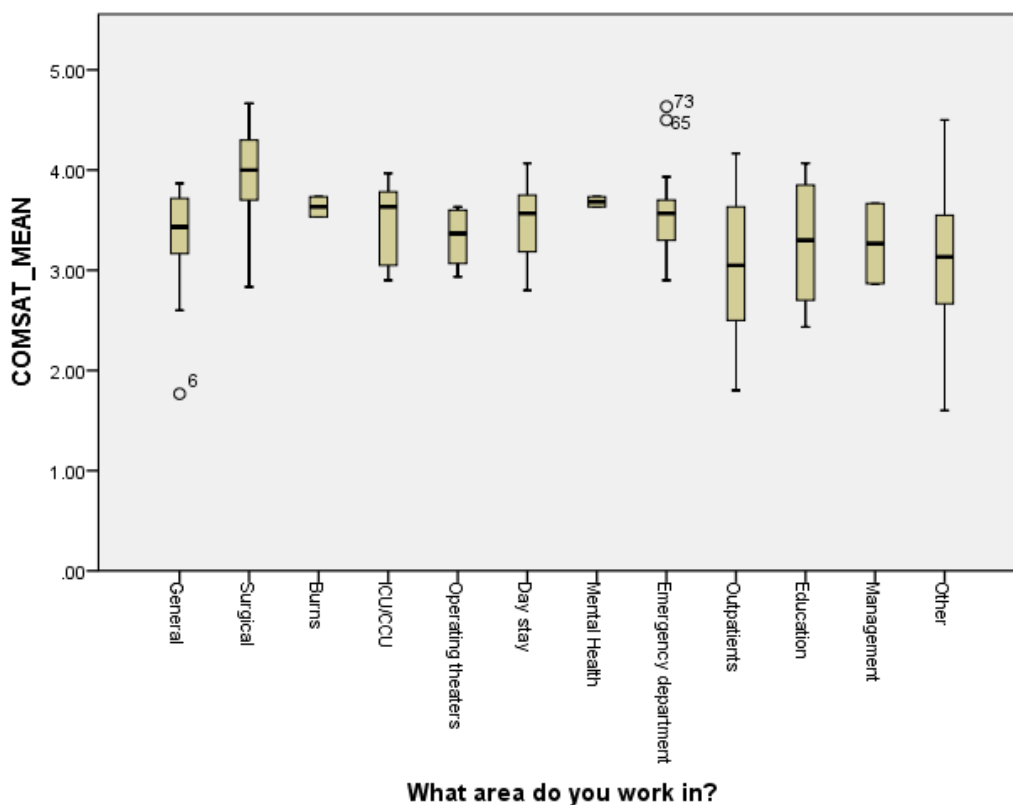

**Figure 9: Communication satisfaction between paediatric nurses and middle managers from different specialty areas**

**Table 16: Mean and median communication satisfaction between paediatric nurses and middle managers from different specialty areas**

Mean and Median Communication Satisfaction Between Paediatric Nurses and Middle Managers from Different Specialty Areas	Mean	Median	Number
General	3.31	3.43	15
Surgical	3.91	4.00	17
Burns	3.63	3.63	2
ICU/CCU	3.45	3.63	7
Operating Theatres	3.32	3.36	8
Day Stay	3.47	3.56	7
Mental Health	3.68	3.68	2
Emergency Department	3.57	3.56	21
Outpatients	3.03	3.05	6
Education	2.27	3.30	4
Management	3.26	3.26	2
Other	3.07	3.13	63

## Communication satisfaction between paediatric nurses and middle managers with different ages and gender

Communication satisfaction between paediatric nurses and middle managers with different ages and gender were graphed onto a box plot (See Figure 10 and Figure 11). Neither of the box plots are normally distributed with most medians either being positively skewed with the median line closer to the bottom or negatively with the median line closer to the top (Coakes & Steed, 2011). Table 17 and Table 18 presents the mean and median communication satisfaction between paediatric nurses and middle managers with different ages and gender. From the box plots and the frequency tables presented, it is apparent that paediatric nurses and middle managers in the 18-29 year old group have higher communication satisfaction median values than other age groups. The communication satisfaction between male and female are very similar.

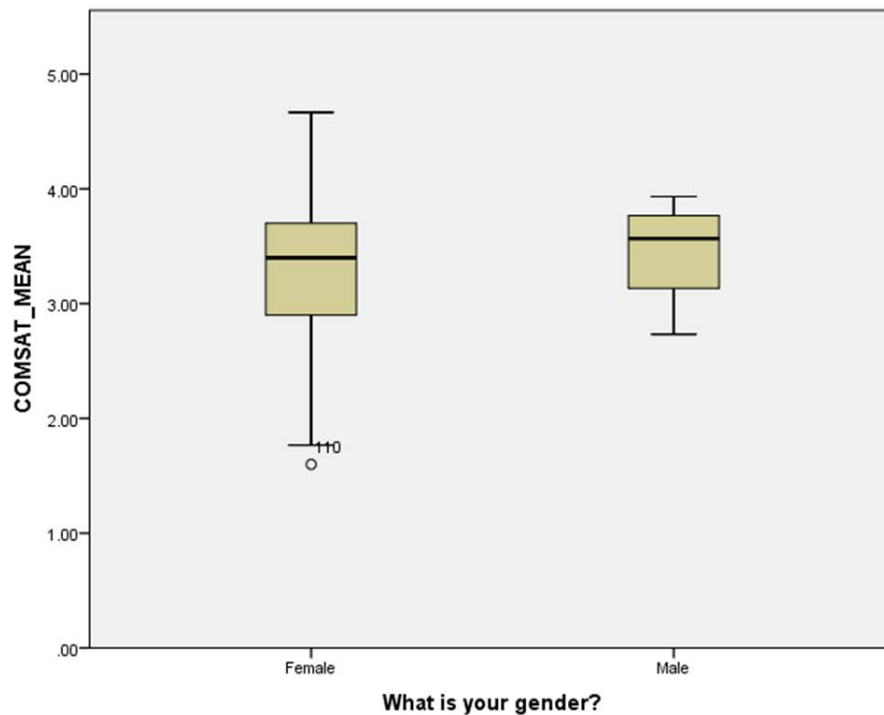

*Figure 10: Communication satisfaction between male and female paediatric nurses and middle managers*

**Table 17: Mean and median communication satisfaction between male and female paediatric nurses and middle managers**

Mean and Median Communication Satisfaction Between Male and Female Paediatric Nurses and Middle Managers	Mean	Median	Number
Female	3.32	3.40	145
Male	3.41	3.56	9

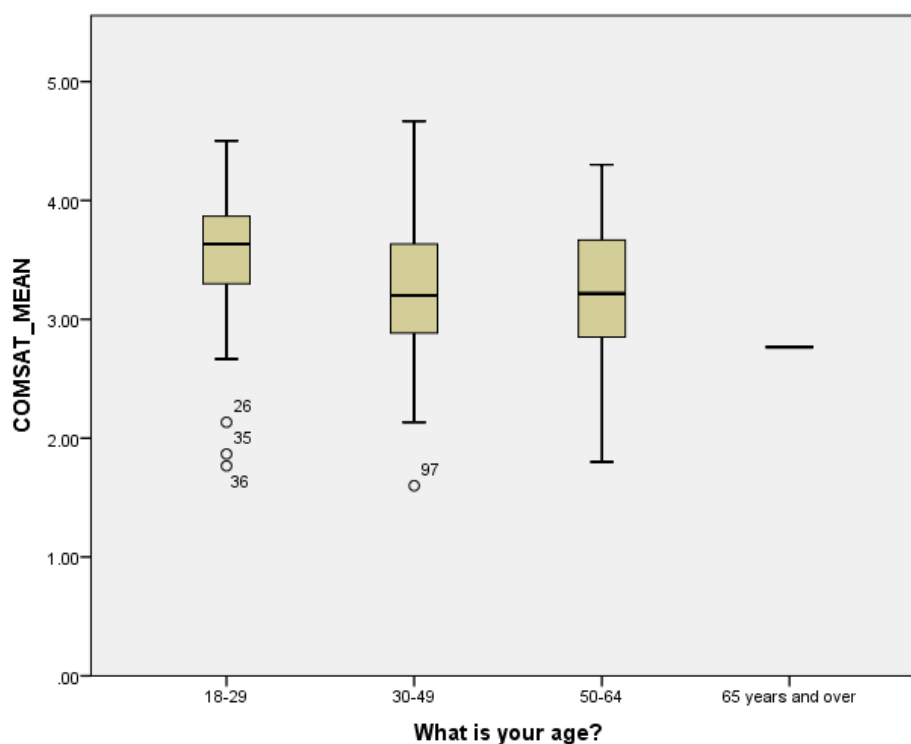

**Figure 11: Communication satisfaction between paediatric nurses and middle managers with different ages**

**Table 18: Mean and median communication satisfaction between paediatric nurses and middle managers with different ages**

Mean and Median Communication Satisfaction Between Paediatric Nurses and Middle Managers with Different Ages	Mean	Medium	Number
18-29 years	3.54	3.63	58
30-49 years	3.20	3.20	71
50-64 years	3.198	3.21	24
65+ years	2.76	2.76	1

## JOB SATISFACTION

The 131 ward nurses were asked to answer 15 questions regarding their job satisfaction using a 5 point Likert scale rating their response from very dissatisfied to very satisfied. Below is a summary and bar graph of paediatric nurses' responses to each item of the job satisfaction questionnaire.

The majority of paediatric nurses were satisfied with the 'physical conditions in which they work' (59, 45%). Ten (7.6%) participants were very satisfied, 27 (20.6%) neither satisfied nor dissatisfied, 26 (19.8%) participants were dissatisfied and nine (7%) very dissatisfied with the 'physical conditions in which they work'. See Figure 12.

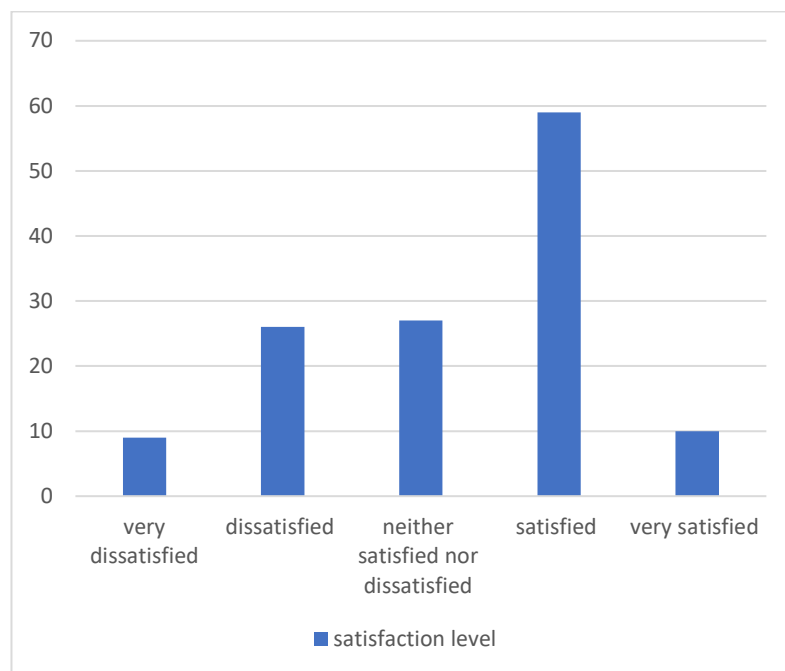

**Figure 12: Summary of paediatric nurses' response to 'The physical condition in which you work'**

For the question 'Freedom to choose your own working methods' the majority of paediatric nurses were satisfied (67, 51%). Nine (7%) participants were very satisfied, 25 (19%) were neither satisfied nor dissatisfied, 24 (18%) were dissatisfied and six (5%) were very dissatisfied with the 'Freedom to choose your own working methods'. See Figure 13.



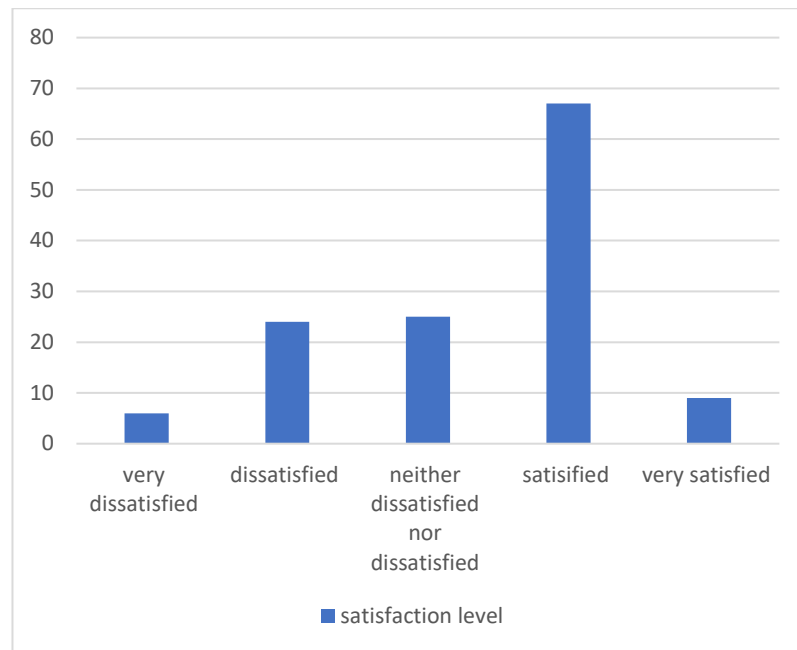

**Figure 13: Summary of paediatric nurses' response to 'Freedom to choose your own working methods'**

The paediatric nurses were asked how satisfied they were with 'your fellow workers'. Out of 131 participants, the majority (75, 57%) were satisfied with their fellow workers. 35 (27%) were very satisfied, 13 (10%) were neither satisfied nor dissatisfied, seven (5.3%) were dissatisfied and one (0.76%) participant was very dissatisfied with 'your fellow workers'. See Figure 14.

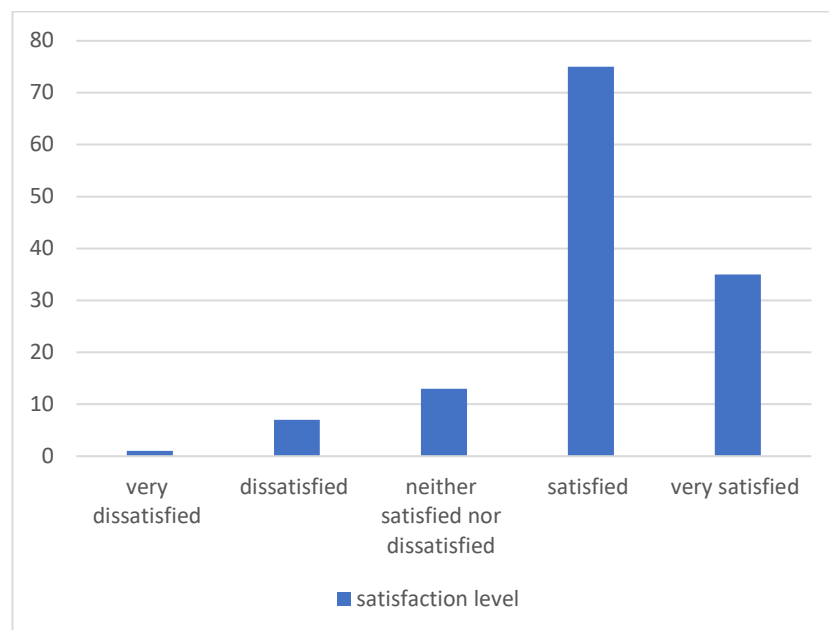

**Figure 14: Summary of paediatric nurses' response to 'Your fellow workers'**

The majority (51, 38.9%) of paediatric nurses were satisfied with ‘the recognition you get for good work’. Ten (7.6%) were very satisfied, 29 (22%) were neither satisfied nor dissatisfied, 26 (20%) were dissatisfied and 15 (11.5%) were very dissatisfied with the ‘recognition you get for good work’. See Figure 15.

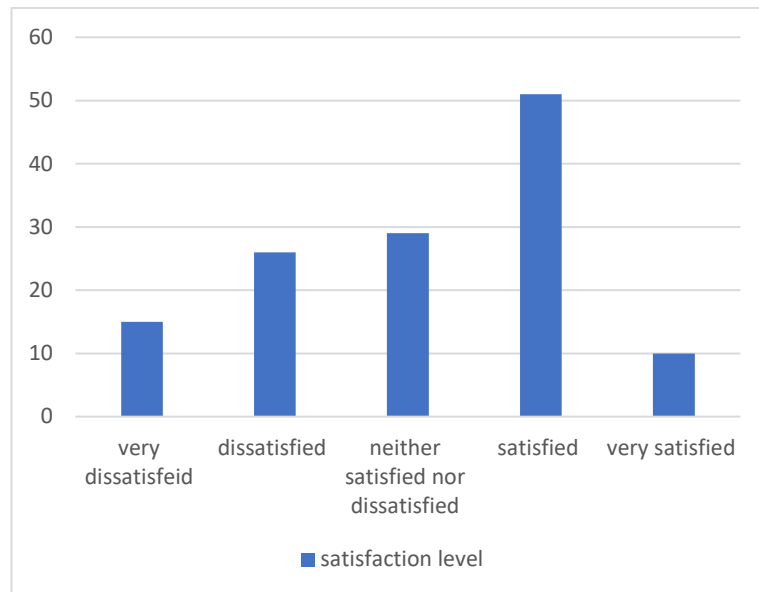

**Figure 15: Summary of paediatric nurses’ response to ‘The recognition you get for your good work’**

The majority of paediatric nurses (50, 38%) were satisfied with their ‘immediate manager’. Thirty one (23.6%) were very satisfied, 22 (17%) were neither satisfied nor dissatisfied, 17 (13%) were dissatisfied and 11 (8.4%) were very dissatisfied. See Figure 16.

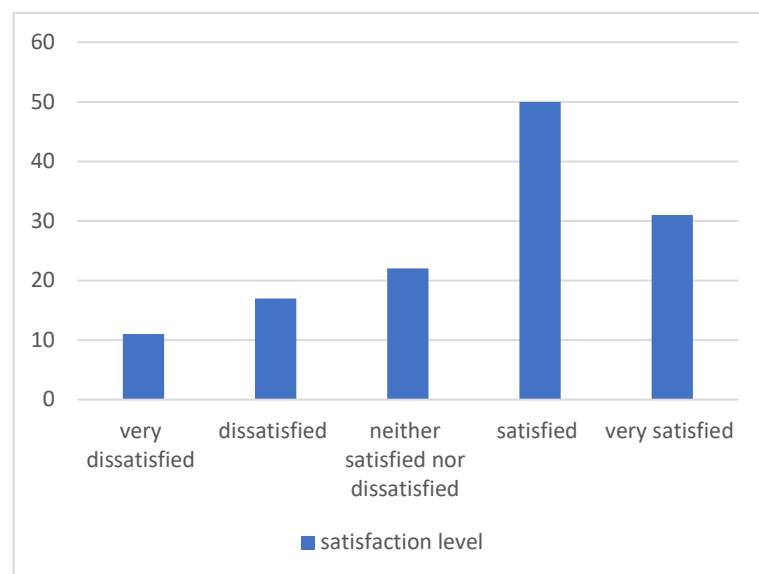

**Figure 16: Summary of paediatric nurses’ response to ‘Your immediate manager’**

For the question ‘the amount of responsibility you are given’ the majority of paediatric nurses were satisfied (72, 55%). 23 (17.5%) were very satisfied, 25 (19%) neither satisfied nor dissatisfied, nine (6.9%) dissatisfied and two (1.5%) very dissatisfied with ‘the amount of responsibility you were given’. See Figure 17.

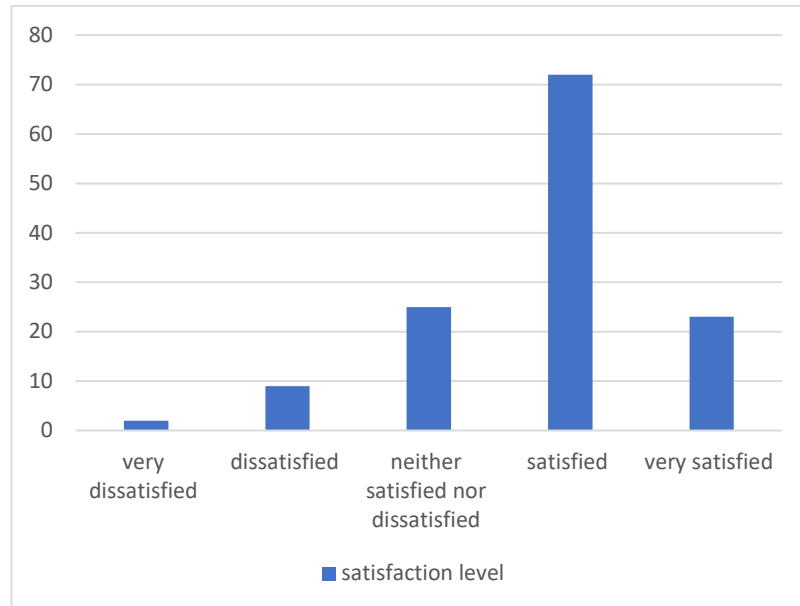

**Figure 17: Summary of paediatric nurses’ response to ‘The amount of responsibility you are given’**

35% (46) of paediatric nurses were satisfied with ‘the rate of pay for nurses’. Six were very satisfied, 26 were neither satisfied nor dissatisfied, 37 were dissatisfied and 16 were very dissatisfied with the ‘rate of pay for nurses’. See Figure 18.

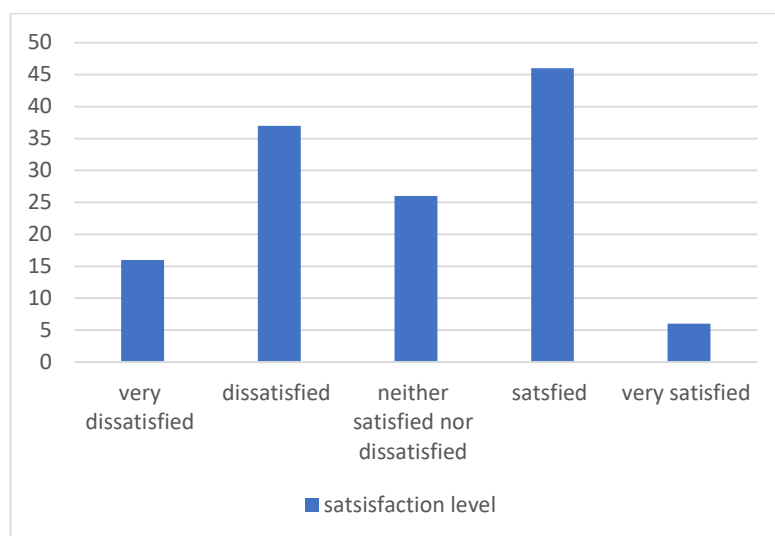

**Figure 18: Summary of paediatric nurses’ response to ‘The rate of pay for nurses’**

The majority of paediatric nurses were satisfied with the ‘opportunity to use your abilities’ (69). Seventeen were very satisfied, 20 neither satisfied nor dissatisfied, 20 were dissatisfied and five were very dissatisfied the opportunity to use their abilities. See Figure 19.

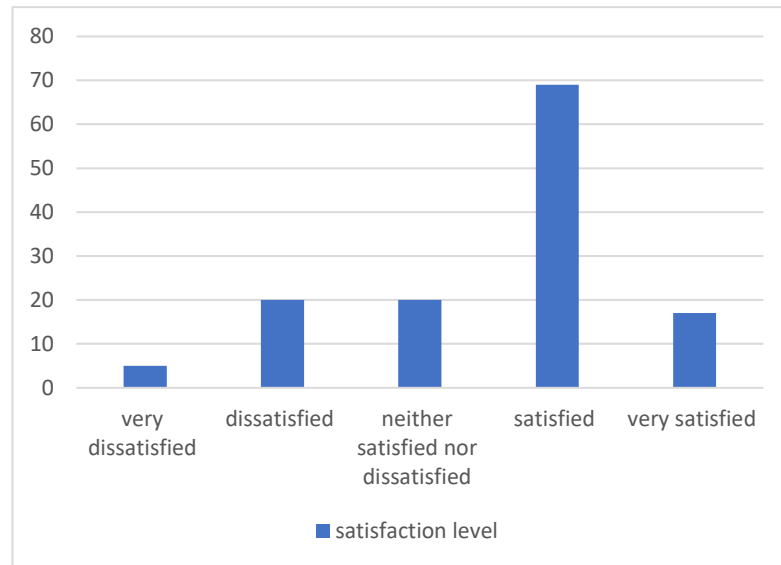

**Figure 19: Summary of paediatric nurses’ response to ‘Opportunity to use your abilities’**

The majority of paediatric nurses (54) were satisfied with their ‘relations between management and staff’. Seventeen were very satisfied, 19 were neither satisfied nor dissatisfied, 33 were dissatisfied and eight were very dissatisfied with ‘the relations between management and staff’. See Figure 20.

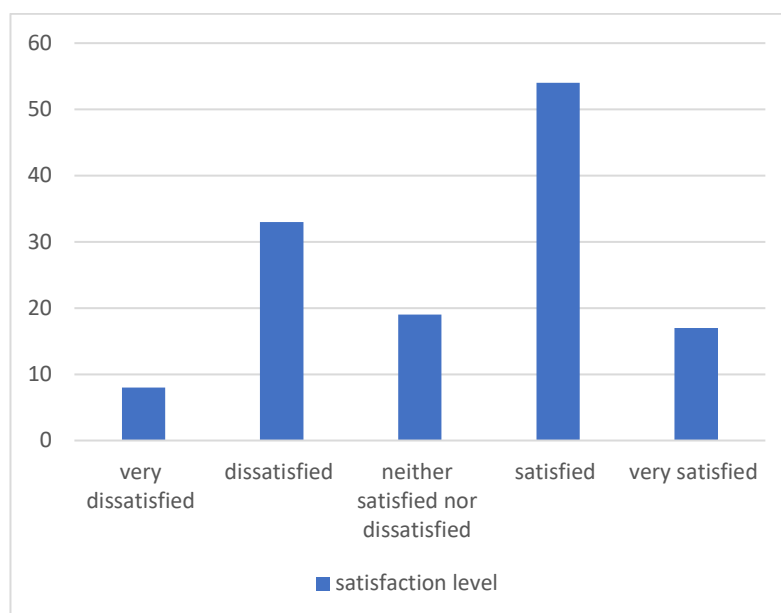

**Figure 20: Summary of paediatric nurses’ response to ‘The relations between management and staff’**

For ‘future chance of promotion’, the majority of paediatric nurses were satisfied (51), six were very satisfied, 40 were neither satisfied nor dissatisfied, 19 were dissatisfied and 15 were very dissatisfied. See Figure 21.

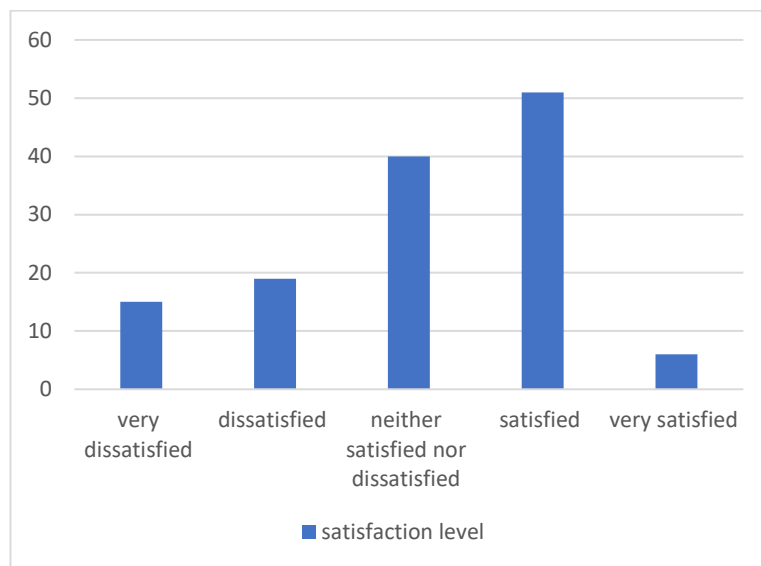

**Figure 21: Summary of paediatric nurses’ response to ‘Future chance of promotion’**

35.5% of the participants rated neither satisfied nor dissatisfied for ‘the way in which the hospital is managed’. Three participants were very satisfied, 28 were dissatisfied and Six were very dissatisfied. See Figure 22.

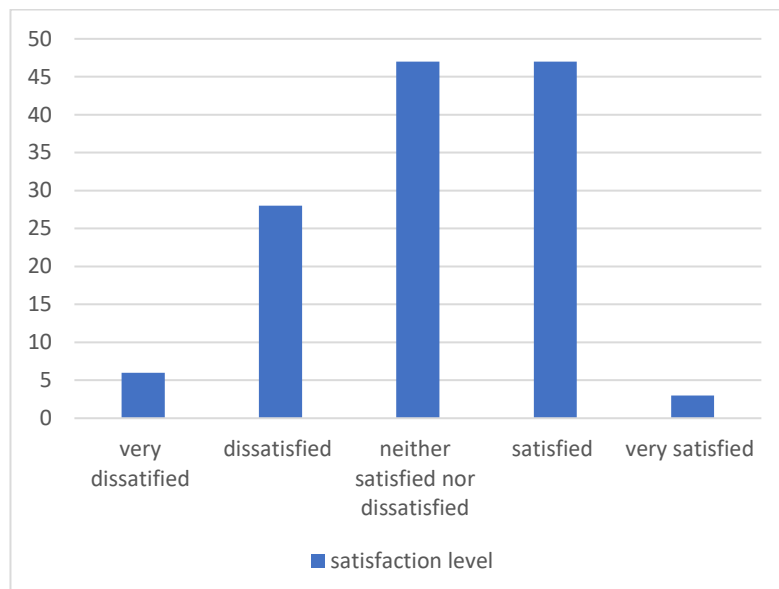

**Figure 22: Summary of paediatric nurses’ response to ‘The way the hospital is managed’**

The majority of paediatric nurses were satisfied with ‘the attention paid to their suggestions’ (46). Six were very satisfied, 45 were neither satisfied nor dissatisfied, 23 were dissatisfied and 11 were very dissatisfied. See Figure 23.

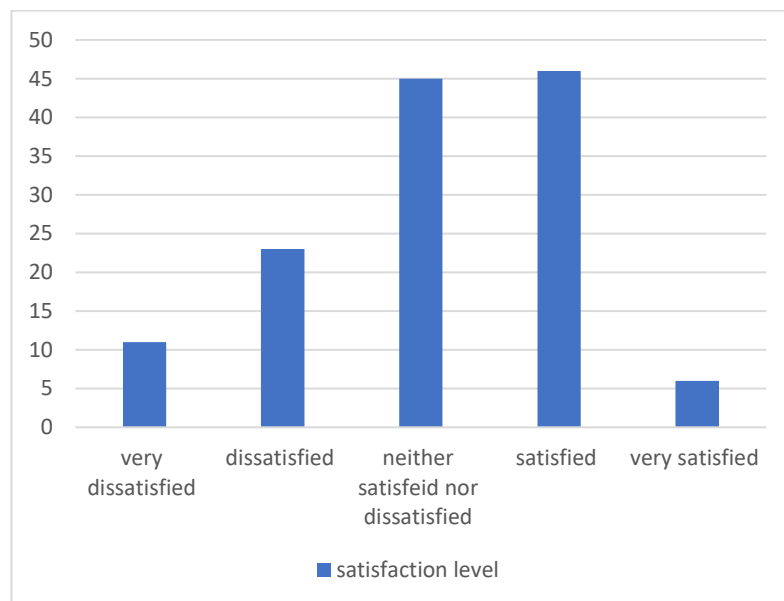

**Figure 23: Summary of paediatric nurses’ response to ‘The attention paid to their suggestions’**

The majority of paediatric nurses were satisfied with the ‘hours of work’ (82). Fifteen were very satisfied, 19 were neither satisfied nor dissatisfied, 11 were dissatisfied and four were very dissatisfied with the ‘hours of work’. See Figure 24.

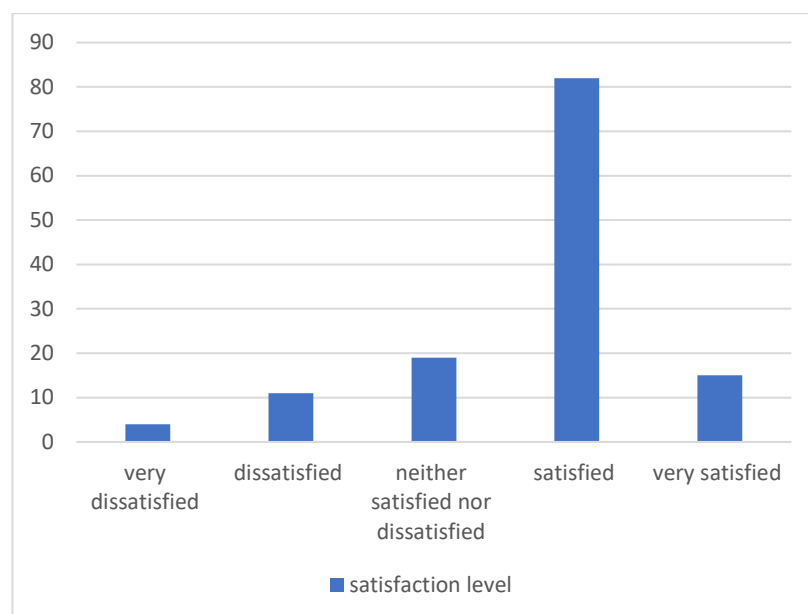

**Figure 24: Summary of paediatric nurses’ response to ‘Hours of work’**

For the question ‘the amount of variety in your job’, the majority of paediatric nurses were satisfied (78). Twenty eight were very satisfied, 16 were neither satisfied nor dissatisfied, six were dissatisfied and three were very dissatisfied. See Figure 25.

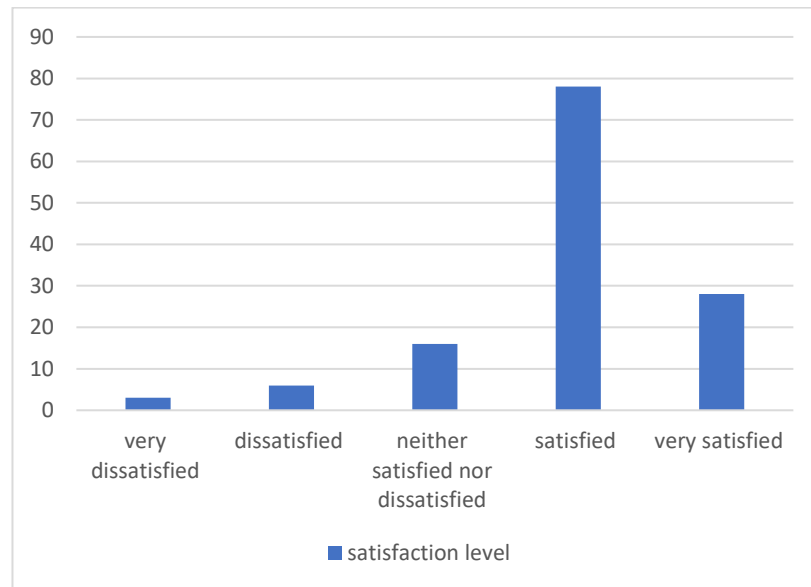

**Figure 25: Summary of paediatric nurses’ response to ‘The amount of variety in your job’**

The majority of paediatric nurses were satisfied with their ‘job security’ (76). Nineteen were very satisfied, 20 were neither satisfied nor dissatisfied, 13 were dissatisfied and three were very dissatisfied with their ‘job security’. See Figure 26.

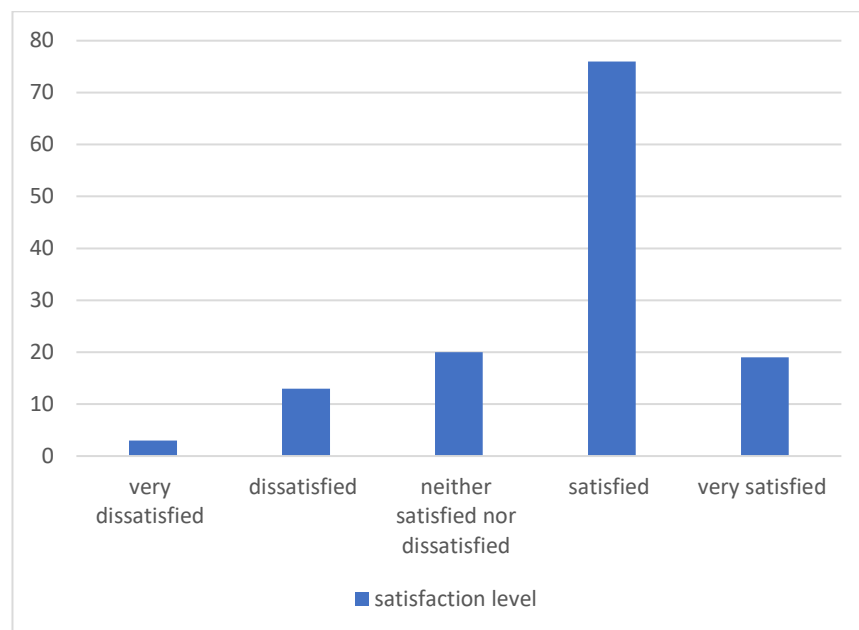

**Figure 26: Summary of paediatric nurses’ response to ‘Your security’**

## PAEDIATRIC NURSES INTENTION TO LEAVE

The 131 ward nurses were asked to answer three questions on their intention to stay in their current job. Paediatric nurses were asked if they were planning to leave their present job, if they were actively looking for another job in nursing and if they were looking for another job how easy or difficult do they think it would be to find an acceptable job in nursing (O'Brien-Pallas et al., 2003). Out of the 131 ward nurses, nine enrolled nurses, 53 registered nurses, 28 clinical nurses and nine staff development nurses has no plans to leave their jobs within the next year. Both clinical development nurses (three) and staff development nurses (one) planned to leave their present nursing job within the next 6 months. One enrolled nurse, nine registered nurses, six clinical nurses and five staff development nurses plan to leave their nursing job within the next year. Table 19 presents a summary of results for the question do you plan to leave your present nursing job?

**Table 19: Do you plan to leave your present nursing job?**

		Frequency	Percent (%)
EN	No plans within the year	9	6.87
	Yes, within the next year	1	0.76
RN	No plans within the year	53	40.6
	Yes, within the 6 months	7	5.3
	Yes, within the next year	9	6.87
CN	No plans within the year	28	21.37
	Yes, within the 6 months	3	2.29
	Yes, within the next year	6	4.58
SDN	No plans within the year	9	6.87
	Yes, within the 6 months	1	0.76
	Yes, within the next year	5	3.8
<b>Total</b>		<b>131</b>	<b>100</b>

For the second question, paediatric nurses were asked if they were actively looking for another position in nursing. Nine enrolled nurses, 49 registered nurses, 27 clinical nurses and eight staff development nurses were not actively looking for a job. There was one enrolled nurse, 20 registered nurses, 10 clinical development nurses and seven staff development nurses that were actively looking for another position in nursing. See Table 20.



**Table 20: Are you actively looking for another position in nursing?**

Position		Frequency	Percent (%)
EN	No	9	6.87
	Yes	1	0.76
RN	No	49	37.4
	Yes	20	15.3
CN	No	27	20.6
	Yes	10	7.63
SDN	No	8	6.10
	Yes	7	5.34
<b>Total</b>		<b>131</b>	<b>100</b>

For the final question, paediatric nurses were asked how easy or difficult it would be to find an acceptable job in nursing. Five enrolled nurses, two registered nurses, two clinical development nurses and one staff development nurses felt that it would be very difficult to find an acceptable job in nursing. Two enrolled nurses 38 registered nurses, 11 clinical nurses and eight staff development nurses felt it would be difficult to find an acceptable job in nursing. Three enrolled nurses, 22 registered nurses, 22 clinical nurses and four staff development nurses felt it would be easy to find an acceptable job in nursing. Of the enrolled nurse population within the sample no one rated finding an acceptable nursing job as very easy, seven registered nurses, two clinical nursed and two staff development nurses felt it would be very easy to find an acceptable job in nursing. Table 21 shows a summary of results.

**Table 21: If you are/were looking for another job how easy or difficult do you think it would be for you to find an acceptable job in nursing?**

Position		Frequency	Percent (%)
EN	Very Difficult	5	3.81
	Difficult	2	1.53
	Easy	3	2.29
RN	Very Difficult	2	1.53
	Difficult	38	29.0
	Easy	22	16.8
	Very Easy	7	5.34
CN	Very Difficult	2	1.53
	Difficult	11	8.39
	Easy	22	16.8
	Very Easy	2	1.53
SDN	Very Difficult	1	0.76
	Difficult	8	6.11
	Easy	4	3.05
	Very Easy	2	1.53
<b>Total</b>		<b>131</b>	<b>100</b>

## DESCRIPTIVE RESULTS

Following examination of the descriptive information, Cronbach's alpha ( $\alpha$ ) was calculated for each of communication satisfaction constructs and the job satisfaction questionnaire. The Cronbach's alpha ( $\alpha$ ) was calculated to allow for examination of the internal consistency reliability prior to the validity confirmation of the measurement models. See Table 22 for a summary of internal consistency and reliability results.

**Table 22: Internal consistency reliability**

Surveys		Alpha (A)
Communication satisfaction questionnaire scale		.953
Construct of the communication satisfaction questionnaire	1) Organisational integration - 5 items	.734
	2) Corporate perspective - 5 items	.842
	3) Communication climate - 5 items	.875
	4) Supervisor relationship - 5 items	.936
	5) Media quality - 5 items	.886
	6) Horizontal communication - 5 items	.829
Job satisfaction questionnaire		.873

An Alpha coefficient ( $\alpha$ ) above .70 is considered to be an acceptable as a measure of internal consistency (Weiner & Craighead, 2010). Therefore, all constructs and the communication satisfaction questionnaire have acceptable levels of internal consistency reliability before measurement model evaluation.

## DATA PREPARATION AND SCREENING

### Multicollinearity

In Structural Equation Modelling, multicollinearity issues leads to inaccurate coefficient estimates and standard error, as well as low power and large confidence intervals (Kline, 2005). In order to prevent this, correlations among study variables were calculated to identify multicollinearity. Correlation coefficient values greater .85 were used to demonstrate evidence of multicollinearity.

Organisational integration was found to have a moderately strong positive correlation with corporate perspective ( $r=.487$   $p<.01$ ), supervisor relationship ( $r=.654$   $p<.01$ ), communication climate ( $r=.631$   $p<.01$ ), horizontal communication ( $r=.500$

$p < .01$ ), media quality ( $r = .629$   $p < .01$ ) and job satisfaction ( $r = .587$   $p < .01$ ). Corporate perspective was found to have a moderately strong positive correlation with, communication climate ( $r = .629$   $p < .01$ ) and media quality ( $r = .578$   $p < .01$ ) and a weak positive correlation with horizontal communication ( $r = .376$   $p < .01$ ), supervisor relationships ( $r = .360$   $p < .01$ ) and job satisfaction ( $r = .358$   $p < .01$ ). Supervisor relationships has a moderately strong positive correlation communication climate ( $r = .682$   $p < .01$ ), horizontal communication ( $r = .549$   $p < .01$ ), media quality ( $r = .695$   $p < .01$ ) and a highly correlated positive relationship with job satisfaction ( $r = .735$   $p < .01$ ). Communication climate has a moderately strong positive correlation with horizontal communication ( $r = .603$   $p < .01$ ) and a highly positive correlation with media quality ( $r = .812$   $p < .01$ ) and a moderately strong positive correlation with job satisfaction ( $r = .603$   $p < .01$ ). Horizontal communication has a moderately strong positive correlation with media quality ( $r = .580$   $p < .01$ ) and job satisfaction ( $r = .586$   $p < .01$ ). Media quality has a strong positive correlation with job satisfaction ( $r = .692$   $p < .01$ ). Table 23 provides a summary of the correlations. None of the correlation coefficients between study variables showed a very high correlation. Therefore, no changes were made to the hypothesised SEM.

*Table 23: Correlation among study variables*

	<b>Organisational Integration</b>	<b>Corporate Perspective</b>	<b>Supervisor Relationship</b>	<b>Communication Climate</b>	<b>Horizontal Communication</b>	<b>Media Quality</b>	<b>Job Satisfaction</b>
Organisational Integration	1						
Corporate Perspective	.487**	1					
Supervisor Relationship	.654**	.360**	1				
Communication Climate	.631**	.629**	.682**	1			
Horizontal Communication	.500**	.376**	.549**	.603**	1		
Media Quality	.629**	.578**	.695**	.812**	.580**	1	
Job Satisfaction	.587**	.358**	.735**	.651**	.586**	.692**	1

Note \*\* Correlation is significant at the 0.01 level (2-tailed).

## Outlier

Extreme values in data can artificially inflate the chi-squared value of a model, which results in false rejection of models as well as underestimation with errors of parameter (Kline, 2005). As a way to counter these extreme values in the data, a z score was made for each variable. The absolute z score of +/-3.29 was used to identify outliers (Boltynkov, 2015). There were no z scores above +/-3.29 for any of the individual items, ruling out the presence of uni-variate outliers. Table 24 presents the z score values for each of the study variables.

*Table 24: Study variables z scores*

	<b>Minimum</b>	<b>Maximum</b>
Job satisfaction	-3.12008	2.33548
Organisational integration	-3.26461	2.55346
Corporate perspective	-2.75113	2.85069
Supervisor relationships	-2.74229	1.43489
Communication climate	-2.29911	2.35639
Horizontal communication	-2.89759	2.35216
Media	-2.85364	2.27126

Mahalanobis distance ( $D^2$ ) test was computed in AMOS<sup>®</sup> during analysis of the model to determine the presence of multivariate outliers. Mahalanobis distance ( $D^2$ ) refers to the distance in terms of standard deviation for a set of scores for an individual case (vector) and the sample mean of all variables in the data set (centroids) (Kline, 2011). The results of the analysis were searched for a high  $D^2$  value and a P2 of less than .001 to signify an outlier. No cases were found to be multivariate outliers in the data.

## MANN-WHITNEY U TEST

The Mann-Whitney U Test is a non-parametric test used to compare the means of two independent groups. To use the Mann-Whitney U Test the following assumptions need to be adhered to:

1. The samples are independent
2. The level of data is at least ordinal (Black, 2012)

The Mann-Whitney u test was used in this study to compare the difference in the responses to the communication satisfaction questionnaire for the two independent

groups, ward nurses and middle managers. The dependent variables in this study were continuous and not normally distributed. Therefore, the Mann-Whitney U Test was an appropriate technique to use. Table 25 provides a summary of the statistically significant differences in the response means between the ward nurses and middle managers.

**Table 25: Statistically significant differences in response mean to the communication satisfaction questions**

Question	Significance
1. Information about my progress in my job	.003
2. Extent to which my supervisor listens and pays attention to me	.029
3. Extent to which my supervisor offers guidance for solving job related problems	.021
4. Extent to which the amount of supervision given me is about right	.031
5. Extent to which the people in my organisation have great ability as communicators	.041
6. Extent to which informal communication is accurate and active	.005
7. Extent to which the attitudes toward communication in the organisation are basically healthy	.011

### **Information about my progress in my job**

‘Information about my progress in my job’ showed a statistically significant difference in response rates between the ward nurse and middle managers with a p value of .003. The difference in responses can be seen in Table 26 which provides a summary of the responses between the two groups. The majority of ward nurses (51.9%, 68) were ‘satisfied’ with the ‘information about my progress in my job’. Only four (3.1%) of the ward nurse group were ‘very dissatisfied’ with the ‘information about my progress in my job’, 19 (14.5%) were ‘dissatisfied’ and 31(23.7%) of the ward nurse group were ‘neither satisfied nor dissatisfied’. Whereas, the majority of the middle managers were ‘dissatisfied’ (10, 43.5%) with the ‘information about my progress in my job’, two (8.7%) were ‘very dissatisfied’, three (13.0%) were ‘neither satisfied nor dissatisfied’ and eight (34.8%) were ‘satisfied’ with the ‘information about my progress in my job’. There were no middle managers who were ‘very satisfied’ with the ‘information about my progress in my job’.

**Table 26: Summary of ward nurses' and managers' satisfaction with the 'information about my progress in my job'**

<b>Ward Nurses' and Middle Managers' Satisfaction with the 'Information about Progress in my Job'</b>	<b>Ward Nurses' Frequency</b>	<b>Middle Managers' Frequency</b>
Very dissatisfied	4	2
Dissatisfied	19	10
Neither satisfied nor dissatisfied	31	3
Satisfied	68	8
Very satisfied	9	-
<b>Total</b>	<b>131</b>	<b>23</b>

### **Extent to which my supervisor listens and pays attention to me**

'The extent to which my supervisor listens and pays attention to me' showed a statistically significant difference in response means between ward nurses and middle managers with a p value of .029. The majority of ward nurses (36.6%, 48) were 'satisfied' with 'the extent to which my supervisor listens and pays attention to me'. There were only six (4.6%) ward nurses who were 'very dissatisfied', 18 (13.75%) were 'dissatisfied', 27 (20.6%) were 'neither satisfied nor dissatisfied' and 32 (24.4%) were 'very satisfied'. This is in contrast to the middle managers group where the majority of middle managers were 'dissatisfied' (10, 43.5%). Only two (8.7%) middle managers were 'very satisfied', three (13.0%) middle managers were 'neither satisfied nor dissatisfied' and eight (34.8%) middle managers were 'satisfied'. There were no middle managers' who were 'very dissatisfied' with 'the extent to which my supervisor listens and pays attention to me'. Table 27 shows a summary of paediatric nurses and middle managers satisfaction with the 'extent to which my supervisor listens and pays attention to me' between the ward nurses and middle managers group.

**Table 27: Summary of paediatric nurses' and managers' satisfaction with the extent to which my supervisor listens and pays attention to me**

<b>Paediatric Nurses' and Middle Managers' Satisfaction with the Extent to Which my Supervisor Listens and Pays Attention to Me</b>	<b>Ward Nurses' Frequency</b>	<b>Middle Mangers' Frequency</b>
Very Dissatisfied	6	-
Dissatisfied	18	10
Neither Satisfied nor Dissatisfied	27	3
Satisfied	48	8
Very Satisfied	32	2
<b>Total</b>	<b>131</b>	<b>23</b>

### **Extent to which my supervisor offers guidance for solving job related problems**

'The extent to which my supervisor offers guidance for solving job related problems' showed to have a statically significant difference in response means between the two groups with a p value of .021. The majority of ward nurses (59, 45%) were 'satisfied', 30 (22.9%) were 'very satisfied', 18 (13.7%) were 'neither satisfied nor dissatisfied', 15 (11.5%) were 'dissatisfied' and nine (6.9%) of the ward nurse group however were 'very dissatisfied', with 'the extent to which my supervisor offers guidance for solving job related problems'. This is in contrast to the middle managers where the majority were equally distributed in the 'dissatisfied' and 'satisfied' category with eight nurses in each (34.85%). There were four (17.4%) who were 'neither satisfied nor dissatisfied', two (8.7%) who were 'very satisfied' and one (4.3%) middle manager who was 'very dissatisfied' with the 'extent to which my supervisor offers guidance for solving job related problems'. Table 28 provides a summary of paediatric nurses' and middle managers satisfaction with the 'extent to which my supervisor offers guidance for solving job related problems'.



**Table 28: Summary of paediatric nurses' and middle managers' satisfaction with the 'extent to which my supervisor offers guidance for solving job related problems'**

<b>Paediatric Nurses' and Middle Managers' Satisfaction with the 'Extent to Which my Supervisor Offers Guidance for Solving Job Related Problems'</b>	<b>Ward Nurses Frequency</b>	<b>Middle Managers' Frequency</b>
Very Dissatisfied	9	1
Dissatisfied	15	8
Neither Satisfied nor Dissatisfied	18	4
Satisfied	59	8
Very Satisfied	30	2
<b>Total</b>	<b>131</b>	<b>23</b>

### **Extent to which the amount of supervision given me is about right**

'The extent to which the amount of supervision given me is about right' showed to have a statically significant difference in response means between the two groups with a p value of .031. The majority of ward nurses were 'satisfied' (65, 49.6%), 30 were 'very satisfied', 25 (19.1%), 'neither satisfied nor dissatisfied' 10 (7.6%) and only one participant (0.76%) in the ward nurse group were 'very dissatisfied'. This was in contrast to the middle managers where the majority were evenly distributed between the 'neither satisfied nor dissatisfied' and 'satisfied' with eight (34.8%) response groups. Three (13.0%) middle managers were 'very satisfied' and four (17.4%) were 'dissatisfied'. There were no middle managers who were 'very dissatisfied' with the 'extent to which the amount of supervision given me is about right'. Table 29 provides a summary of nurses and middle managers satisfaction with the 'extent to which the amount of supervision given me is about right'.

**Table 29: Summary of paediatric nurses' and middle managers' satisfaction with the 'extent to which the amount of supervision given to me is about right'**

<b>Paediatric Nurses' and Middle Managers' Satisfaction with the Extent to Which the Amount of Supervision Given to Me is About Right</b>	<b>Ward Nurses' Frequency</b>	<b>Middle Mangers' Frequency</b>
Very Dissatisfied	1	-
Dissatisfied	10	4
Neither Satisfied nor Dissatisfied	25	8
Satisfied	65	8
Very Satisfied	30	3
<b>Total</b>	<b>131</b>	<b>23</b>

### **Extent to which the people in my organisation have great ability as communicators**

The 'extent to which the people in my organisation have great ability as communicators' showed to have a statistically significant difference in response means between the two groups with a p value of .041. The majority of ward nurses (50, 38.2%) were 'satisfied', 34 (26.0%) were 'neither satisfied nor dissatisfied', 33 (25.2%) were 'dissatisfied', nine (6.9%) were 'very satisfied' and five (3.8%) were 'very dissatisfied' with the 'extent to which the people in my organisation have great abilities as communicators'. This is in contrast to the middle managers group where the majority nine (39.1%) were 'dissatisfied', eight (34.8%) were 'neither satisfied nor dissatisfied', five (21.7%) were 'satisfied' and only one (4.3%) middle managers were 'very dissatisfied'. There were no middle managers who were 'very satisfied' with the 'extent to which the people in my organisation have great abilities as communicators'. Table 30 provides a summary of paediatric nurses' and middle managers satisfaction with the 'extent to which the people in my organisation have great abilities as communicators'.

**Table 30: Summary of paediatric nurses' and middle managers' satisfaction with the 'extent to which people in my organisation have great abilities as communicators'**

<b>Paediatric Nurses' and Middle Managers' Satisfaction with the Extent to Which People in my Organisation have Great Abilities as Communicator's</b>	<b>Ward Nurses Frequency</b>	<b>Middle Managers Frequency</b>
Very Dissatisfied	5	1
Dissatisfied	33	9
Neither Satisfied nor Dissatisfied	34	8
Satisfied	50	5
Very Satisfied	9	-
Total	131	23

### **Extent to which informal communication is accurate and active**

'The extent to which informal communication is accurate and active' showed to have a statically significant difference in response means between the two groups with a p value of .005. The majority of ward nurses (68, 51.9%) were 'satisfied', 39 (29.8%) were 'neither satisfied nor dissatisfied', 13 (9.9%) were 'very satisfied' and 11 (8.4%) of the ward nurse group were 'dissatisfied' with the 'extent to which informal communication is accurate and active'. This is in contrast to the middle managers group where the majority (9, 39.1%) were 'satisfied', seven (30.4%) were 'neither satisfied nor dissatisfied', six (26.1%) were 'dissatisfied' and only one (4.3%) middle manager was 'very dissatisfied'. There were no middle managers who were 'very satisfied' with the 'extent to which informal communication is accurate and active'. Table 31 provides a summary of paediatric nurses' and middle managers satisfaction with the 'extent to which informal communication is accurate and active'.

**Table 31: Summary of paediatric nurses' and middle manager's satisfaction with the 'extent to which informal communication is accurate and active'**

<b>Paediatric Nurses' and Middle Manager's Satisfaction with the 'Extent to Which Informal Communication is Accurate and Active'</b>	<b>Ward Nurses Frequency</b>	<b>Middle Managers Frequency</b>
Very Dissatisfied	-	1
Dissatisfied	11	6
Neither Satisfied nor Dissatisfied	39	7
Satisfied	68	9
Very Satisfied	13	-
Total	131	23

## **Extent to which the attitudes toward communication in the organisation are basically healthy**

‘The extent to which the attitudes towards communication in the organisation are basically healthy’ showed to have a statically significant difference in response means between the two groups with a p value of .011. The majority of ward nurses (61, 46.6%) were ‘satisfied’, 34 (26%) were ‘neither satisfied nor dissatisfied’, 25(19.1%) were ‘dissatisfied’, seven (5.3%) were ‘very satisfied’ and four (3.1%) were ‘very dissatisfied’ with the ‘extent to which the attitudes toward communication in the organisation are basically healthy’. This is in contrast to the middle managers group where the majority nine (39.1%) were ‘dissatisfied’, seven (30.4%) were ‘neither satisfied nor dissatisfied’, six (26.1%) were ‘satisfied’ and only one (4.3%) middle manager was ‘very dissatisfied’. There were no middle managers’ who were ‘very satisfied’ with the ‘extent to which attitudes toward communication are basically healthy’. Table 32 provides a summary of paediatric nurses’ and middle managers’ satisfaction with the ‘extent to which the attitudes toward communication are basically healthy’.

**Table 32: Summary of paediatric nurses’ and middle managers’ satisfaction with the ‘extent to which the attitudes toward communication are basically healthy’**

<b>Paediatric Nurses’ and Middle Managers’ Satisfaction with the ‘Extent to Which the Attitudes Toward Communication are Basically Healthy’</b>	<b>Ward Nurses Frequency</b>	<b>Middle Managers Frequency</b>
Very Dissatisfied	4	1
Dissatisfied	25	9
Neither Satisfied nor Dissatisfied	34	7
Satisfied	61	6
Very Satisfied	7	-
Total	131	23

## **SUMMARY**

In this chapter the survey response rate, sampling demographics and contextual results were presented. Of the surveys and information sheets that were distributed 164 surveys were returned. After screening the data for missing values and unengaged responses a final sample size of 154 paediatric nurses and middle managers were retained for the study. Based on 154 valid responses the majority of the participants

were female, in the 30-49 age category and worked full time with a bachelor degree in nursing.

Following calculation of study demographics, a Mann-Whitney U Test was completed to assess the difference in communication satisfaction between paediatric nurses and middle managers. Information about my progress in my job, extent to which my supervisor listens and pays attention to me, extent to which my supervisor offers guidance for solving job related problems, extent to which the amount of supervision given me is about right, extent to which the people in my organisation have great ability as communicators, extent to which informal communication is accurate and active, and extent to which the attitudes toward communication in the organisation are basically healthy, were all significantly different with middle managers being less satisfied than nurses group. Chapter 5 will present the results from the SEM analysis.

---

# **CHAPTER 5: PHASE 1 STRUCTURAL EQUATION MODELLING RESULTS**

## **INTRODUCTION**

This chapter will present the results of the modelling analysis from the study. First, the measurement model is presented with a description of the Congeneric Factor Analysis, Confirmatory Factor Analysis, validity, reliability, common method bias and modifications that were undertaken. Secondly, the SEM will be examined with a description of the Structural Equation Hypothesised Model and the alternative hypothesised models that were tested. Also, age, position, years of experience, area of work and highest level of education will be examined to identify if there is a statistically significant difference between paediatric nurses looking for another job. Job satisfaction, intention to leave their current job and looking for another job are also examined in a SEM in order to identify the significance of the relationships between the variables. A comparison between the models and the hypotheses are also made.

## **HYPOTHESISED CONCEPTUAL MODEL**

The hypothesised conceptual model for this study was created from a review of theoretical and empirical literature. The literature review indicated that positive and effective communication leads to an increase in work satisfaction and work commitment. Furthermore, by maintaining open, (Mrayyan, 2008) and effective communication (Chu et al., 2003), nursing retention and reduction in nursing turnover can be achieved (Jasper, 2007). As supported by previous literature, an organisational communication satisfaction and effect hypothesised conceptual model (Figure 5) was constructed based on the premise that paediatric nurses' organisational communication satisfaction has a direct impact on job satisfaction and intention to leave their current job and looking for another job. Organisational communication satisfaction can be categorised into five dimensions, namely; communication climate, organisational integration, media quality, horizontal communication and corporate perspective (Downs, 1994). For this conceptual model the endogenous variables are job satisfaction and intention to leave their current job and looking for another job. The exogenous variable is communication satisfaction. See Figure 2 for illustration of hypothesised

SEM of paediatric nurses' communication satisfaction and its effects on job satisfaction and intention to leave their current job and looking for another job. Figure 3 presents the hypothesised SEM of paediatric nurses' job satisfaction and its effects on intention to leave one's job, and looking for another job. The participant demographics of age, position and years in position were used as controls in the hypothesised model.

## MEASUREMENT MODEL

First, each construct within the communication satisfaction questionnaire underwent a Congeneric Factor Analysis to identify the extent to which each item is a valid measure of its construct (Bryne, 2010). Following the Congeneric Factor Analysis, a Confirmatory Factor Analysis (CFA) was conducted. The hypothesised model was then reviewed before the SEM was analysed. This section details the findings from the congeneric measurement model analysis.

### Model fit

Model fit indices were used to measure the goodness of fit in the Congeneric model and later in the CFA and SEM. The Chi-squared ( $\chi^2$ ) was used to assess the discrepancy between the covariance matrix and the hypothesised model. A non-significant value greater than .05 was used as evidence of a good fit (Kline, 2005). As it is challenging to achieve a non-significant chi-square value (Kline, 2005), model fit was also determined using Standardised Root Mean Square Residual (SRMR), Comparative Fit Index (CFI), Root Mean Square Error of Approximation (RMSEA) and pCLOSE (Blunch, 2013). Measurement error covariance or Modification Indices were also used (MI) to modify the models. Items were removed in order from highest to lowest MI with each model reanalysed after an item was removed. See Table 33 for a summary of goodness of fit indices.

**Table 33: Goodness of fit indices used for the SEM**

Model Fit Indices	Desirable Value
Chi- square ( $\chi^2$ )	>.05
Standardised Root Mean Square Residual (SRMR)	<.05
Comparative Fit Index (CFI)	>.95
Root Mean Square Error of Approximation (RMSEA)	<.05
pCLOSE	>.05

## Congeneric Factor Analysis

The congeneric measurement theory is used to measure the relationships between items and a common construct. A congeneric model can be evaluated within the context of a CFA as a congeneric model has observed and latent variables (Christenson et al., 2012). Each of the communication satisfaction constructs were analysed using Congeneric Factor Analysis and goodness of fit indices presented in Table 33.

### *Organisational integration*

The items for organisational integration were subjected to Congeneric Factor Analysis. The items representing organisational integration are displayed in Table 34.

**Table 34: Survey item and labels for organisational integration**

Survey Item	Model Label
1. Information about my progress in my job	OrgInt_1
2. Personnel news	OrgInt_2
<b>3. Information about benefits and pay</b>	<b>OrgInt_3</b>
4. Information about the requirements of my job	OrgInt_4
5. Information about departmental policies and goals	OrgInt_5

Note: the items that were deleted are in bold

The initial congeneric model indicated an inadequate fit for organisational integration ( $\chi^2= 25.332$ ,  $p$  value=.000, SRMR= .0660, CFI=.879, RMSEA= .177, pCLOSE=.001) (See Figure 27).

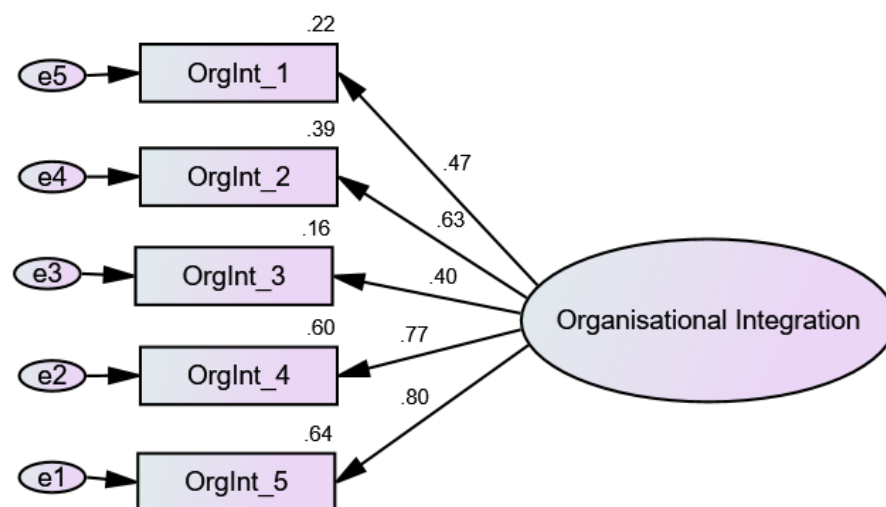

**Figure 27: Initial congeneric model for organisational integration**



The MI was reviewed revealing a covariance between errors for item 3 and 5 (err1 and err 3; MI = 7.603, Par change -.121), which indicated that 3 and 5 were caused by organisational integration and an unknown omitted construct. Hence, item 3 was removed from the model. The revised model was re-analysed. The resulting model showed substantial improvement in goodness of fit ( $\chi^2=7.493$ , p value=.024, SRMR=.0502, CFI=.960, RMSEA= .145 and pCLOSE=.056). The revised model indicated that item 1 and 2 were caused by organisational integration and an unknown construct. Based on this, the Squared multiple correlations, standardised residual covariance and regression weight, item 1 and 2 were constrained. The revised model was re-analysed. The resulting model showed substantial improvement and good fit indices ( $\chi^2=.510$ , p value= .475, SRMR=.0099, CFI= 1.00, RMSEA=.000 and pCLOSE=.542) (See Figure 28).

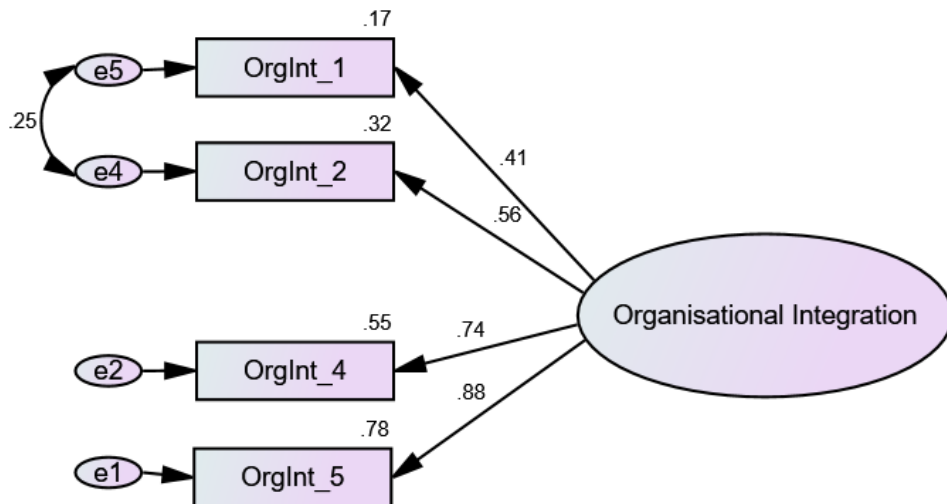

**Figure 28: Final congeneric model for organisational integration**

There were no modification indices resulting from the Congeneric Factor Analysis and therefore no further modifications were necessary.

Table 35 displays the goodness of fit statics and modification indices for organisational integration. The revised congeneric model showed adequate internal consistency reliability ( $\alpha=.750$ ).

**Table 35: Goodness of fit statistics and modification indices for organisational integration**

Item deleted	$\chi^2$ (df)	P value	CFI	RMSEA (CI)	SRMR	pCLOSE	MI (Par change)
	25.332(5)	0.00	.879	.177 (.112-.248)	.0660	.001	Err4 → err5 5.235 (.101) Err3 → err4 7.211(.123) Err2 → err4 4.909(-.060) Err1 → err3 7.603(-.121)
#3	7.493(2)	.024	.960	.145(.045-.263)	.0502	.056	Err4 → err5 5.235 (.101)
Covaried err4 and err5	.510(1)	.475	1.000	.000(.000-.206)	.0099	.542	NIL

Note: Goodness of fit is indicated by p value >.05, SRMR <.05, CFI >.95, RMSEA <.05, pCLOSE >.05

*Corporate perspective*

The items for corporate perspective were subjected to a Congeneric Factor Analysis. The items representing corporate perspective are displayed in Table 36.

**Table 36: Survey item and labels for corporate perspective**

Survey Item	Model Label
1. Information about organisational policies and goals	CorpPer_1
<b>2. Information about changes in our organisation</b>	<b>CorpPer_2</b>
3. Information about government action affecting my organisation	CorpPer_3
4. Information about our organisations financial standing	CorpPer_4
5. Information about accomplishments and/or failures of the organisation	CorpPer_5

Note: the items that were deleted are in bold

The initial congeneric model indicated an inadequate fit for corporate perspective ( $\chi^2= 17.143$ , p value= .004, SRMR= .0468, CFI= .955, RMSEA= .137, pCLOSE=.021) (See Figure 29).

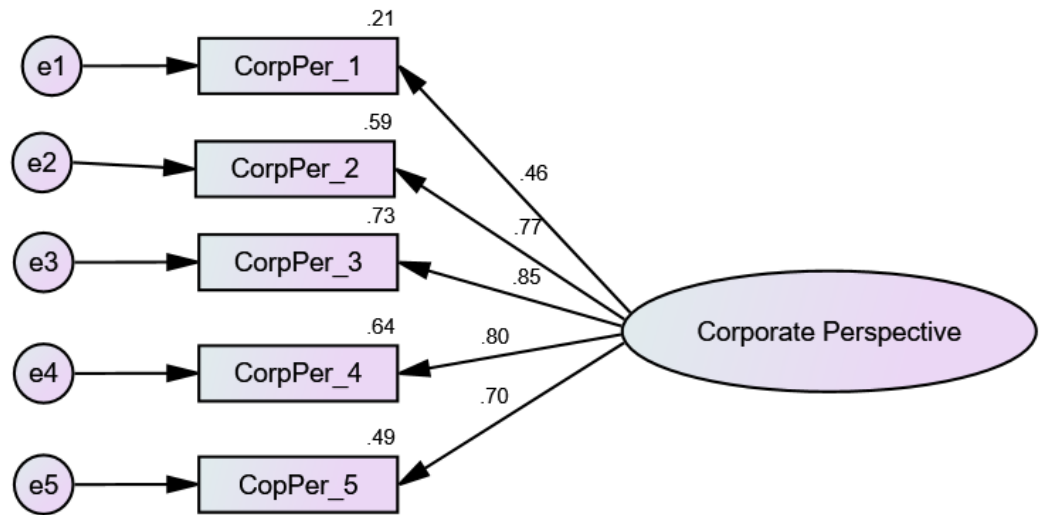

**Figure 29: Initial congeneric model for corporate perspective**

The MI was reviewed revealing an error between errors for item 1 and 2 (err1 and err 2; MI = 9.307, Par change .123), which indicated that 1 and 2 were caused by corporate perspective and an unknown omitted construct. Hence, item 2 was removed from the congeneric model. The revised congeneric model was re-analysed. The resulting model showed substantial improvement in goodness of fit ( $\chi^2=1.506$ , p value=.471, SRMR=.0176, CFI=1.0, RMSEA= .000 and pCLOSE=.575) (See Figure 30).

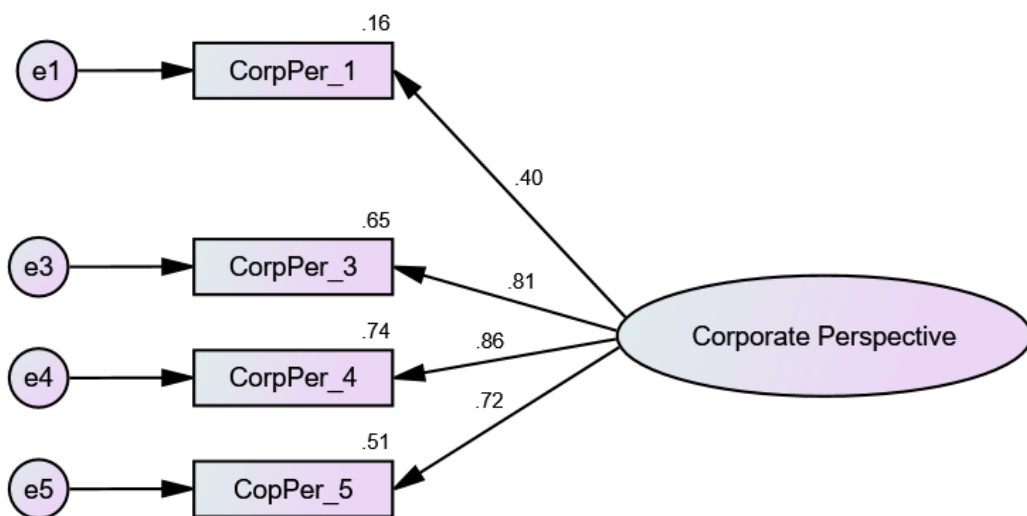

**Figure 30: Final congeneric model for corporate perspective**

There were no modification indices resulting from the Congeneric Factor Analysis and therefore no further modifications were necessary.

Table 37 displays the goodness of fit statics and modification indices for corporate perspective. The revised congeneric model showing adequate internal consistency reliability ( $\alpha=.788$ ).

**Table 37: Goodness of fit statistics and modification indices for corporate perspective**

Removed	$\chi^2(df)$	P Value	CFI	RMSEA	SRMR	pCLOSE	MI (Par Change)
	17.143(5)	.004	.955	.137(.069-.210)	.0468	.021	err3 → err4 9.307(.123) err 5 → err 1 4.348(.063)
#2	1.506(2)	.471	1.000	.000(.000-.160)	.0176	.575	NIL

Note: Goodness of fit is indicated by p value >.05, SRMR <.05, CFI >.95, RMSEA <.05, pCLOSE >.05

#### *Communication climate*

The items for communication climate were subjected to a Congeneric Factor Analysis. The items representing communication climate are displayed in Table 38.

**Table 38: Survey item and labels for communication climate**

Survey Item	Model Label
1. Extent to which the people in my organisation have great ability as communicators	ComClim_1
<b>2. Extent to which I receive, in time, the information needed to do my job</b>	<b>ComClim_2</b>
3. Extent to which conflicts are handled appropriately through proper communication channels	ComClim_3
4. Extent to which the organisation's communication makes me identify with or feel a vital part of it	ComClim_4
5. Extent to which the organisation's communication motivates and stimulates an enthusiasm for meeting its goals	ComClim_5

Note: the items that were deleted are in bold

The initial congeneric model indicated an inadequate fit for communication climate ( $\chi^2= 14.989$  p value= .010, SRMR= .0390, CFI= .970, RMSEA= .124, pCLOSE=.041) (See Figure 31).

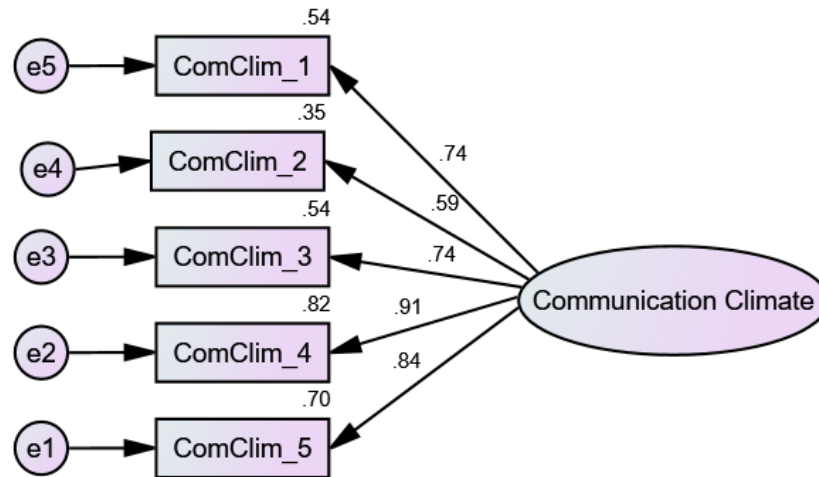

**Figure 31: Initial congeneric model for communication climate**

The MI was reviewed revealing an error between errors for item 1 and 3 (err1 and err 3; MI = 6.031, Par change .120), which indicated that 1 and 3 were caused by communication climate and an unknown omitted construct. Item 1 and 3 were constrained and the revised congeneric model was re-analysed. The resulting congeneric model showed improvement in goodness of fit ( $\chi^2=8.319$ , p value=.081, SRMR=.0293, CFI=.987, RMSEA= .091 and pCLOSE=.117). There were no modification indices resulting from the congeneric factor analysis. As the RMSEA was above .05 the squared multiple correlations, standardised residual covariance and regression weights were reviewed and as a result question 2 was removed. The revised congeneric model was re-analysed. The revised model showed substantial improvement ( $\chi^2=.012$ , p value =.911, SRMR=.0010, CFI=1.00, RMSEA= .000 and pCLOSE=.925). Figure 32 illustrates the final congeneric model for communication climate.

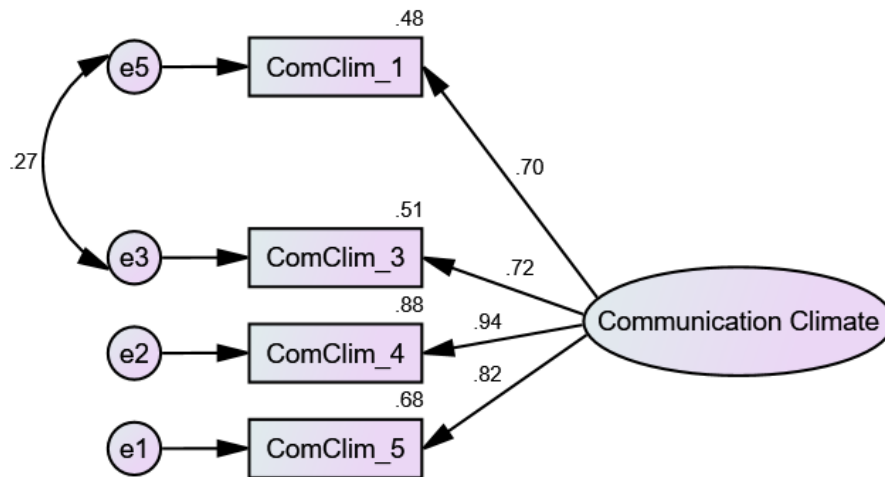

**Figure 32: Final congeneric model for communication climate**

There were no modification indices resulting from the Congeneric Factor Analysis and therefore no further modifications were necessary.

Table 39 displays the goodness of fit statistics and Modification Indices for Communication Climate. The revised congeneric model showed high internal consistency reliability ( $\alpha=.880$ ).

**Table 39: Goodness of fit statistics and modification indices for communication climate**

Removed	$\chi^2(df)$	P value	CFI	RMSEA	SRMR	pCLOSE	MI (Par Change)
	14.989(5)	.010	.970	.124(.055-.199)	.0390	.041	Err3 → err5 6.031(.120)
Constrained err3 and err5	8.319(4)	.081	.987	.091(.000-.179)	.0293	.177	nil
#2	.012(1)	.911	1.000	.000(.000-.094)	.0010	.925	nil

Note: Goodness of fit is indicated by p value > .05, SRMR < .05, CFI > .95, RMSEA < .05, pCLOSE > .05

### *Supervisor relationships*

The items for supervisor relationships were subjected to a Congeneric Factor Analysis. The items representing supervisor relationships are presented in Table 40.

**Table 40: Survey item and labels for supervisor relationships**

Survey Item	Model Label
1. Extent to which my supervisor listens and pays attention to me	SupRel_1
2. Extent to which my supervisor offers guidance for solving job related problems	SupRel_2
3. Extent to which my supervisor trusts me	SupRel_3
4. Extent to which the amount of supervision given me is about right	SupRel_4
5. Extent to which my supervisor is open to ideas	SupRel_5

Note: no items were deleted

The initial congeneric model indicated an adequate fit for supervisor relationships ( $\chi^2 = 4.176$  p value = .524, SRMR = .0123, CFI = .1.00, RMSEA = .000, pCLOSE = .686) (See Figure 33).

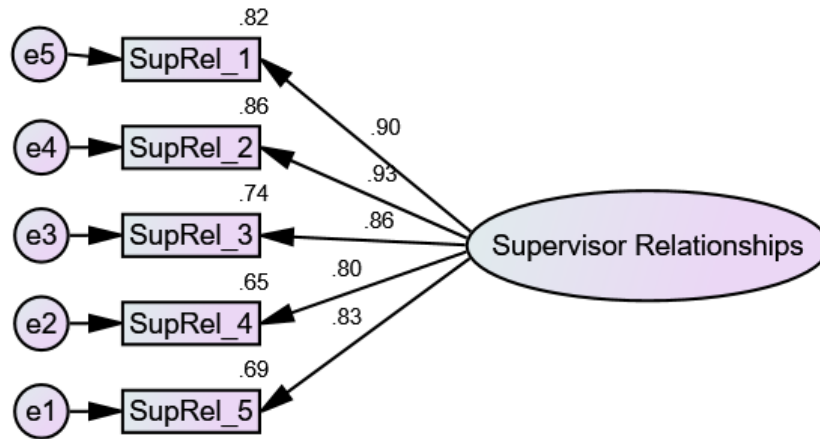

**Figure 33: Initial congeneric model for supervisor relationships**

No Modification Indices resulted from the Congeneric Factor Analysis and therefore no further modifications were necessary. Figure 34 illustrates the final congeneric model for supervisor relationships.

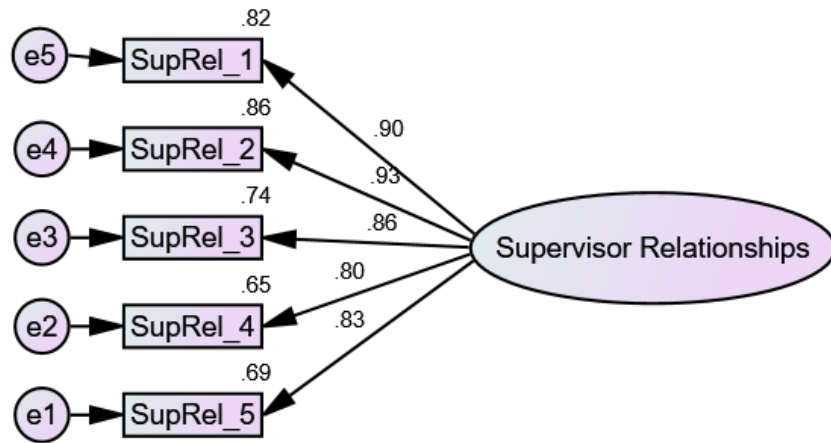

**Figure 34: Final congeneric model for supervisor relationships**

Table 41 displays the goodness of fit statistics and Modification Indices for supervisor relationships.

The revised congeneric model showed high internal consistency reliability ( $\alpha=.936$ ).

**Table 41: Goodness of fit statistics and modification indices for supervisor relationships**

Removed	$\chi^2(df)$	P value	CFI	RMSEA	SRMR	pCLOSE	
	4.176(5)	.524	1.000	.000(.000-.111)	.0123	.686	Nil

Note: Goodness of fit is indicated by p value >.05, SRMR <.05, CFI >.95, RMSEA <.05, pCLOSE >.05

*Media quality*

The items for media quality were subjected to a Congeneric Factor Analysis. The items representing media quality are presented in Table 42.

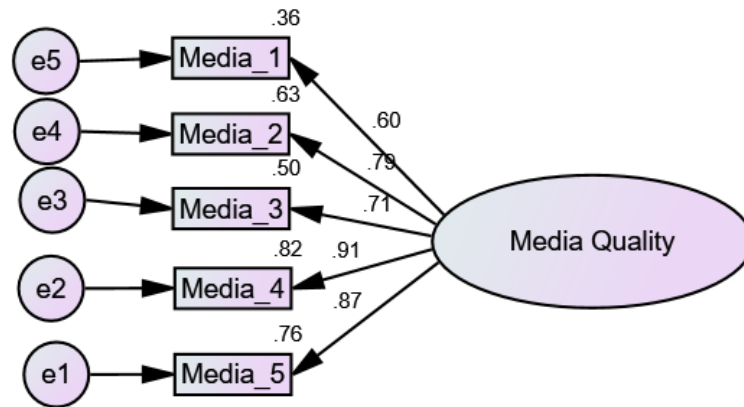

**Table 42: Survey item and labels for media quality**

Survey Item	Model Label
1. Extent to which written directives and reports are clear and concise	Media_1
2. Extent to which the attitudes toward communication in the organisation are basically healthy	Media_2
<b>3. Extent to which our meetings are well organised</b>	<b>Media_3</b>
4. Extent to which the amount of communication in the organisation is about right	Media_4
5. Extent to which the organisation's communications are interesting and helpful	Media_5

Note: the items that were deleted are in bold

The initial model indicated an inadequate fit for media quality ( $\chi^2= 14.530$ , p value= .013, SRMR= .0370, CFI= .974, RMSEA= .121 pCLOSE=.048) (See Figure 35).



**Figure 35: Initial congeneric model for media quality**

The MI was reviewed revealing an error between errors for item 1 and 2 (err1 and err 2; MI= 7.847, Par change .100). Items 1 and 2 were constrained and the revised congeneric model was re analysed. The resulting congeneric model showed improvement in goodness of fit ( $\chi^2=6.008$ , p value=.199, SRMR=.0267, CFI=.995, RMSEA= .062 and pCLOSE=.342). There were no modification indices resulting from the Congeneric Factor Analysis, however the RMSEA was still above .050. Based on this the squared multiple correlations, standardised residual covariance and regression weights were reviewed and item 3 was removed. The resulting model showed substantial improvement ( $\chi^2=.166$ , p value=.684, SRMR=.0036, CFI=1.00, RMSEA=.000 and pCLOSE=.729). Figure 36 illustrates the final congeneric model for Media quality.

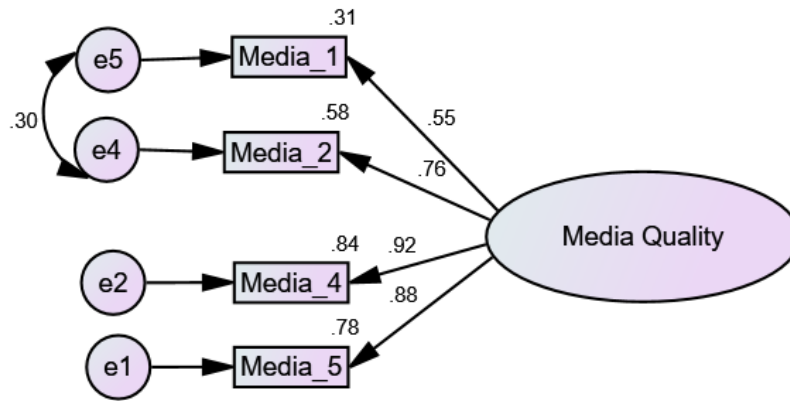

**Figure 36: Final congeneric model for media quality**

No modification indices resulted from the Congeneric Factor Analysis. Table 43 displays the goodness of fit statistics and Modification Indices for media quality. The revised congeneric model showed adequate internal consistency reliability ( $\alpha=.873$ ).

**Table 43: Goodness of fit statistics and modification indices for media quality**

Removed	$\chi^2(df)$	P value	CFI	RMSEA	SRMR	pCLOSE	MI (Par change)
	14.530(5)	.013	.974	.121(.051-.196)	.0370	.048	Err4 → err5 7.847 (.100)
Constrained err4-err5	6.008(4)	.199	.995	.062(.000-.157)	.0267	.342	Nil
#3	.166(1)	.684	1.000	.000(.000-.173)	.0036	.729	NIL

Note: Goodness of fit is indicated by p value >.05, SRMR <.05, CFI >.95, RMSEA <.05, pCLOSE >.05

### *Horizontal communication*

The items for horizontal communication were subjected to Congeneric Factor Analysis. The items representing horizontal communication are presented in Table 44.

**Table 44: Survey item and labels for horizontal communication**

Survey Item	Model Label
1. Extent to which horizontal (peers) communication with other organisational members is accurate and free flowing	HorizComm_1
<b>2. Extent to which communication practices are adaptable to emergencies</b>	<b>HorizComm_2</b>
3. Extent to which my work group is compatible	HorizComm_3
4. Extent to which informal communication is accurate and active (Informal communication refers to social relationships)	HorizComm_4
5. Extent to which the grapevine is active in our organisation	HorizComm_5

Note: the items that were deleted are in bold

The initial congeneric model indicated an inadequate fit for horizontal communication ( $\chi^2= 17.051$  p value= .004, SRMR= .0458, CFI= .946, RMSEA= .136, pCLOSE=.021) (See Figure 37).

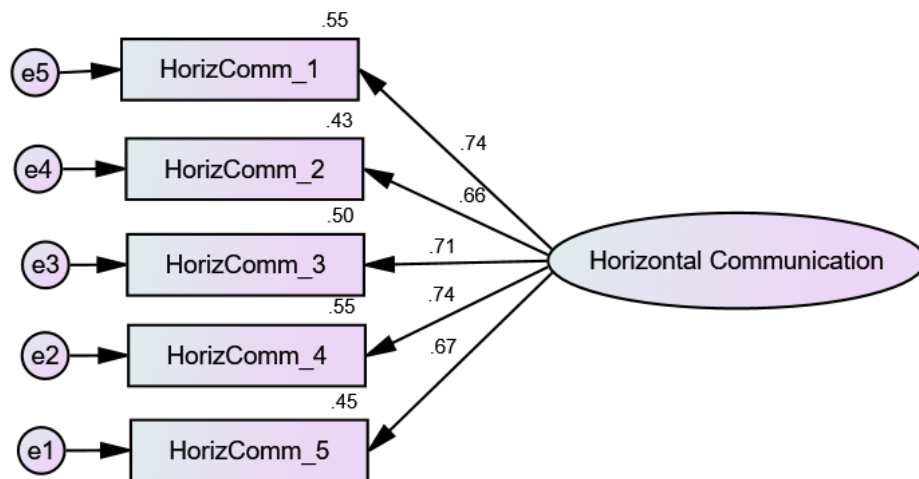

**Figure 37: Initial congeneric model for horizontal communication**

Based on this the squared multiple correlations, standardised residual covariance and regression weights were reviewed and item 2 was removed. The revised model was re-analysed. The resulting model showed improvement in goodness of fit ( $\chi^2=3.217$ , p value=.200, SRMR=.0251, CFI=.992, RMSEA= .068 and pCLOSE=.301) (See Figure 38).

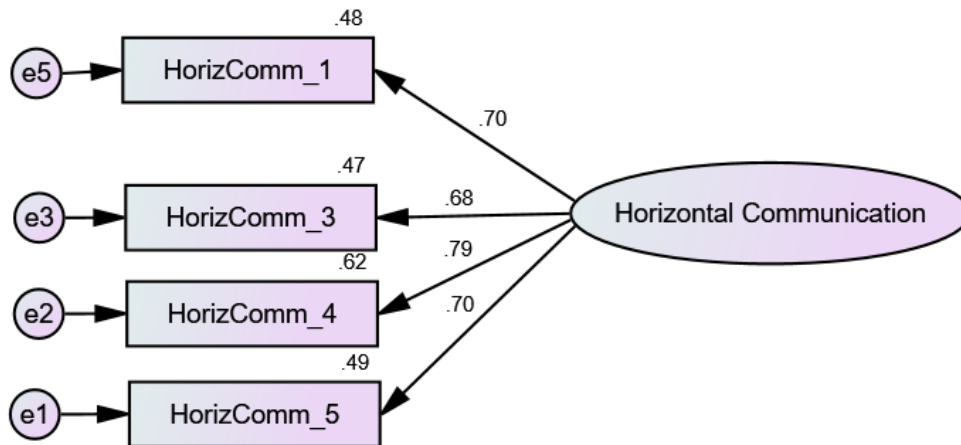

**Figure 38: Final congeneric model for horizontal communication**

No further modifications were necessary. Fit indices are presented in Table 45. The revised congeneric model showed adequate internal consistency reliability ( $\alpha=.806$ ).

**Table 45: Goodness of fit statistics and modification indices for horizontal communication**

Removed	$\chi^2(df)$	P value	CFI	RMSEA	SRMR	pCLOSE	MI (Par Change)
	17.051(5)	.004	.946	.136(.069-.210)	.0458	.021	Err3 → err5 4.12(-.069)
#2	3.217(2)	.200	.992	.068(.000-.200)	.0251	.301	Nil

Note: Goodness of fit is indicated by p value > .05, SRMR < .05, CFI > .95, RMSEA < .05, pCLOSE > .05

### Confirmatory Factor Analysis

Following the Congeneric Factor Analysis, a Confirmatory Factor Analysis (CFA) was conducted for the communication satisfaction questionnaire. The model fit indices, presented in Table 33 were used in the confirmatory factor analysis as a measure of goodness of fit. Figure 39 illustrates the CFA model for testing.

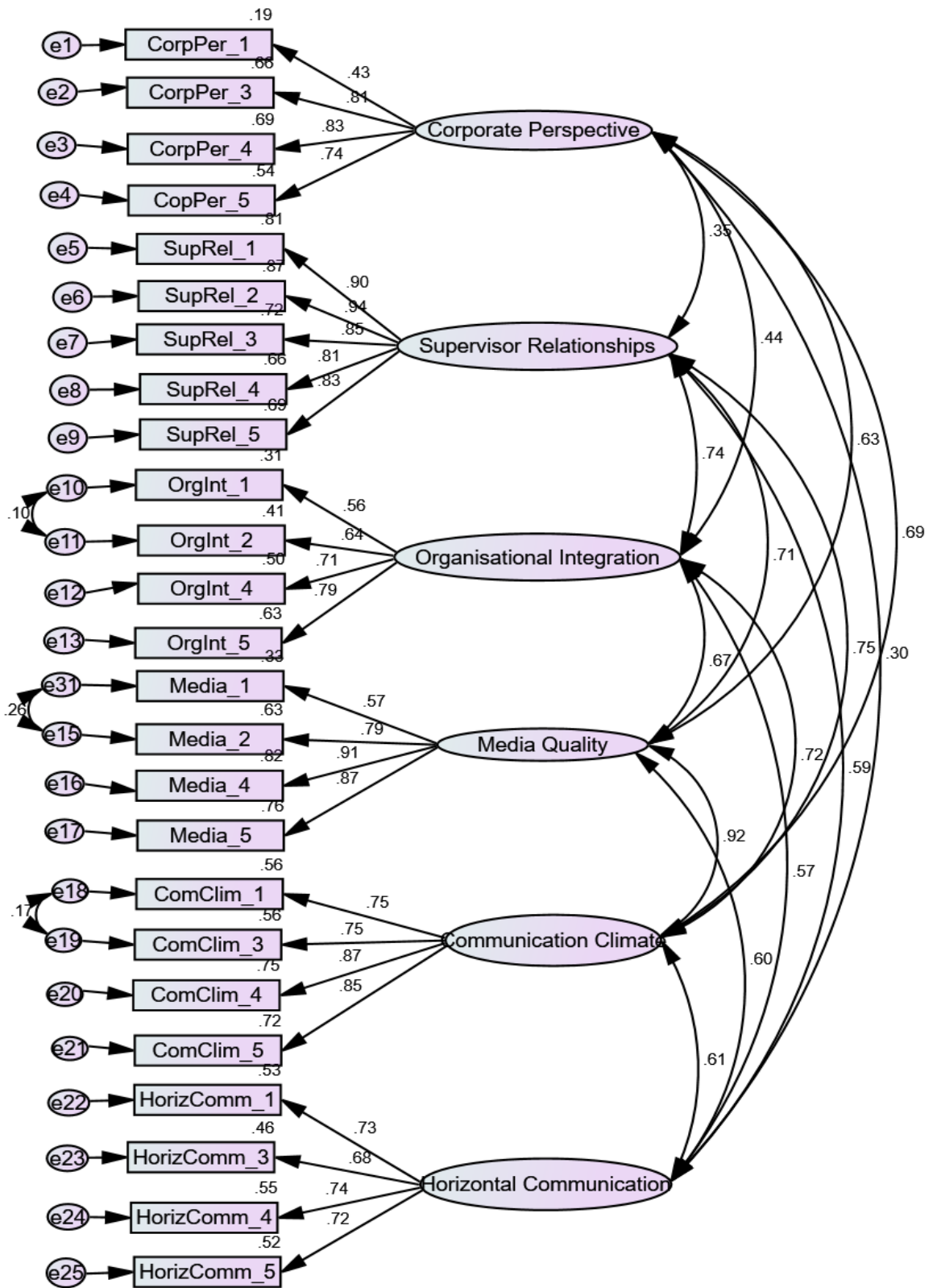

Figure 39: Initial CFA model for organisational communication satisfaction

The initial CFA showed inadequate model fit indices (see Table 46).

**Table 46: Goodness of fit indices for the initial CFA model**

<b><math>\chi^2</math>(df)</b>	<b>P value</b>	<b>CFI</b>	<b>RMSEA</b>	<b>SRMR</b>	<b>pCLOSE</b>
447.452(257)	.000	.913	.076(.064-.087)	.0740	.000

Higher order factor analysis was conducted for media quality and communication climate due to a high covariance of .92. High covariance can affect validity between variables (Kline, 2011). This was supported by examining the correlations matrix for relationships among factors. Inter-correlations above .70 indicate that factors may be measuring the same construct (Tabachnik & Fidell, 1996). Finch and West (1997), suggest that for constructs that are highly correlated, a higher order factor analysis should be conducted. Likewise, Gray and Laidlaw (2004), noted that a CFA for the organisational communication satisfaction survey should be considered in terms of a hierarchical structure. As shown in Table 47 communication climate and media quality are highly correlated ( $r = .818, p < 0.01$ ). Therefore, higher factor analysis was conducted.

*Table 47: Intercorrelations between composite factors*

	<b>Organisational Integration</b>	<b>Corporate Perspective</b>	<b>Supervisor Relationship</b>	<b>Communication Climate</b>	<b>Horizontal Communication</b>	<b>Media Quality</b>
Organisational Integration	1					
Corporate Perspective	.487**	1				
Supervisor Relationship	.654**	.360**	1			
Communication Climate	.631**	.629**	.682**	1		
Horizontal Communication	.500**	.376**	.549**	.603**	1	
Media Quality	.629**	.578**	.695**	.812**	.580**	1

Note \*\* Correlation is significant at the 0.01 level (2-tailed).

Following this, an analysis was conducted for the combined media and communication climate model (see Figure 40).

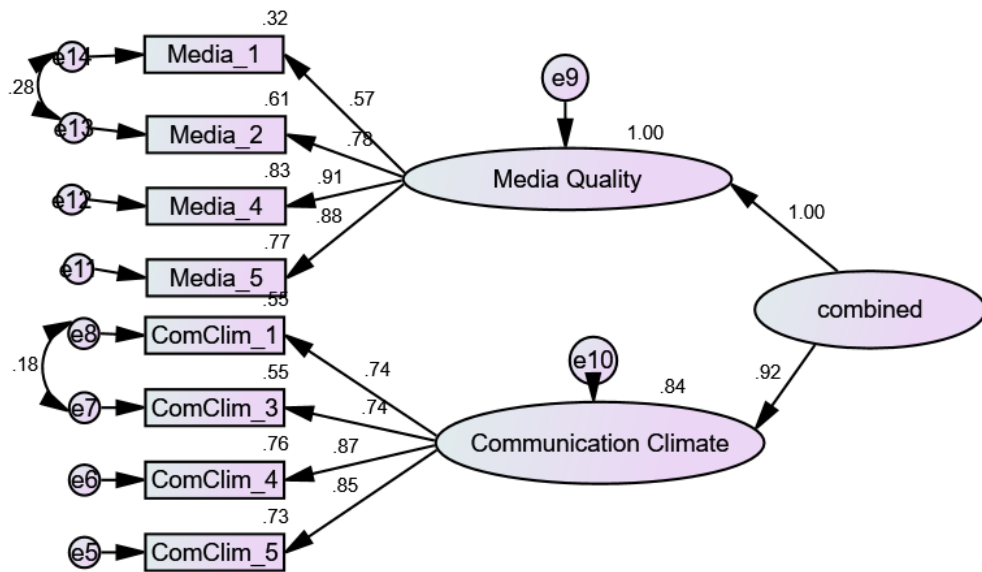

**Figure 40: Higher order factor analysis for media and communication climate**

The CFA was revised to include the higher order factor analysis for media quality and communication climate as shown in Figure 41.



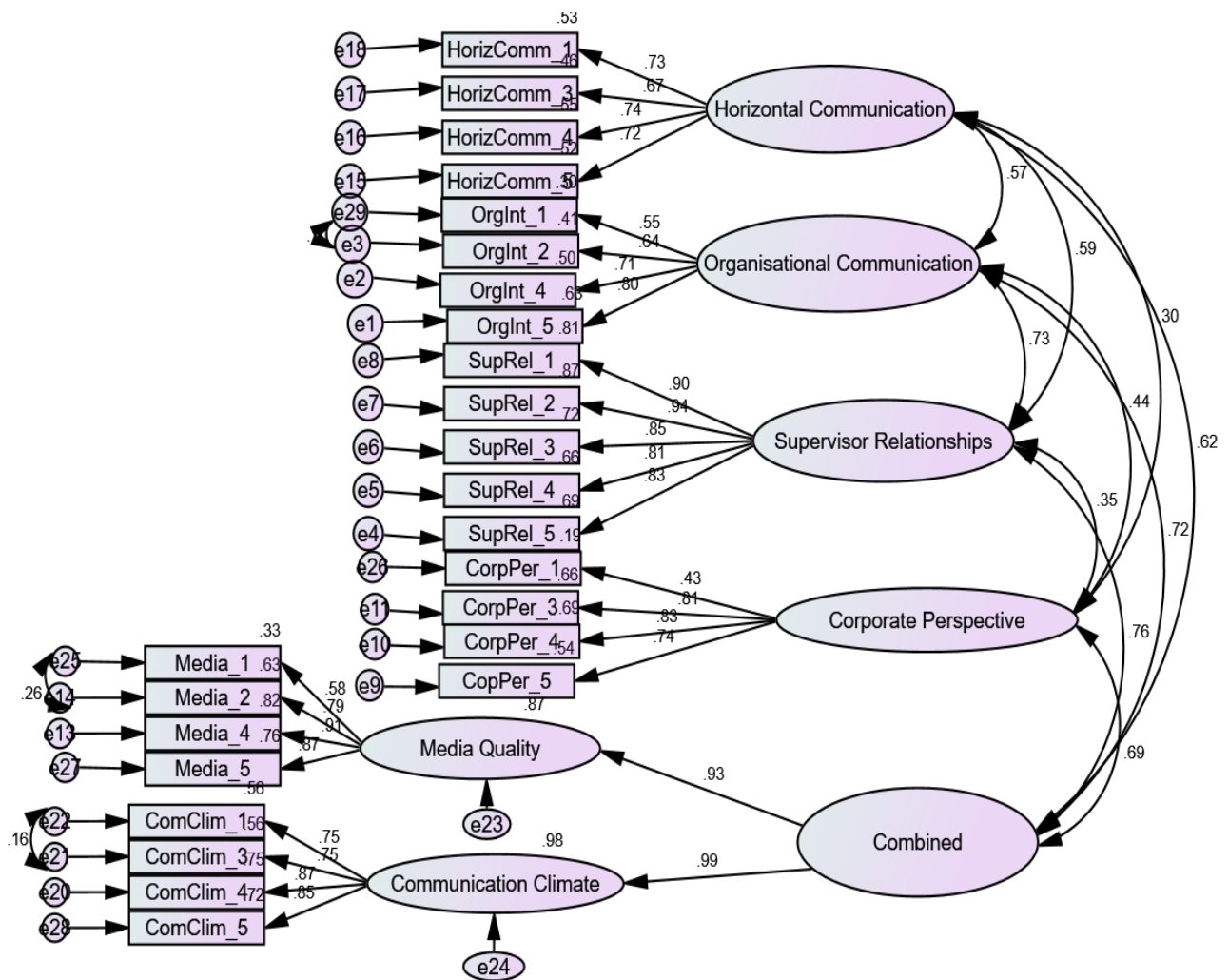

Figure 41: Revised CFA model

The revised CFA showed inadequate model fit. The fit indices, squared multiple correlations, standardised residual covariance and regression weights were reviewed and item corporate perspective 1 and organisational integration 1 were removed. Table 48 shows the goodness of fit indices for the revised CFA along with fit indices after item removal.

Table 48: Goodness of fit indices for the revised CFA model and removal of items

Question removed	$\chi^2(df)$	P value	CFI	RMSEA	SRMR	pCLOSE
	447.832(260)	.000	.914	.075(.063-.086)	.0740	.001
CorpPer_1	352.092(237)	.000	.945	.061(.047-.074)	.0618	.090
Orgint_1	299.388(216)	.000	.959	.054(.039-.069)	.0585	.303

The revised model was re-analysed. The resulting CFA model showed substantial improvement from the initial model. Figure 42 illustrates the final CFA model. The revised CFA model showed adequate internal consistency reliability ( $\alpha=.946$ ).

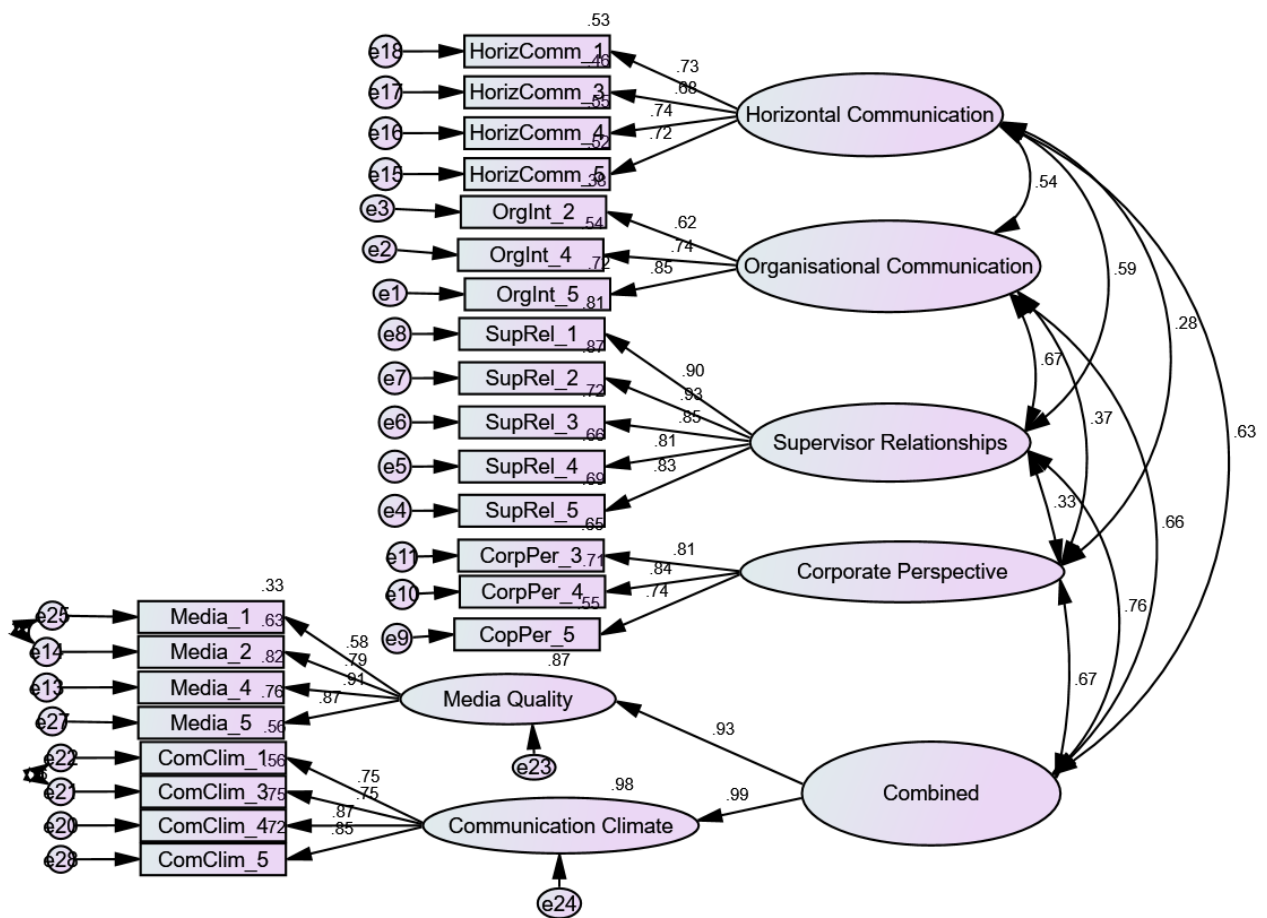

Figure 42: Final CFA model

#### Validity and composite reliability

It is necessary to establish convergent and discriminant validity testing as well as composite reliability when doing a CFA before testing a casual model. Convergent validity establishes how well the latent factor is explained by the observed variable, and the discriminant validity establishes if the latent factor is better explained by some other factor (Hair, Black, Babin, & Anderson, 2010). Validity and composite reliability were established using the following measures; composite reliability (CR), average variance extracted (AVE), maximum hared variance (MSV) and average shared variance (ASV). The CR should be greater than 0.7 ( $>0.7$ ), AVE is used for testing convergent validity and should be greater than 0.5 ( $>0.5$ ). The MSV and ASV are used to measure discriminant validity. The MSV and the ASV should be smaller than the AVE ( $MSV < AVE$ ,  $ASV < AVE$ ). Discriminant validity can also be measured by the square root of the AVE

being greater than the inter-construct correlations (Hair et al., 2010). Table 49 presents the validity and composite reliability statistics for the CFA. All factors had composite reliability values greater than 0.7. Therefore, there are no reliability issues with the CFA. There are no issues with convergent validity in the CFA as all AVE values are greater than 0.5. discernment validity is measured by the MSV and the ASV. The CFA has no discernment validity issues as the MSV is and the ASV are smaller than the AVE.

*Table 49: Validity and composite reliability statistics*

	<b>CR</b>	<b>AVE</b>	<b>MSV</b>	<b>ASV</b>	<b>Corporate</b>	<b>Organisational</b>	<b>Supervisor</b>	<b>Horizontal</b>	<b>Combined</b>
<b>Corporate</b>	0.840	0.637	0.453	0.195	0.798				
<b>Organisational</b>	0.781	0.547	0.445	0.329	0.372	0.740			
<b>Supervisor</b>	0.938	0.751	0.578	0.369	0.328	0.667	0.866		
<b>Horizontal</b>	0.809	0.514	0.391	0.277	0.284	0.540	0.587	0.717	
<b>Communication climate/Media quality</b>	0.961	0.924	0.578	0.465	0.673	0.663	0.760	0.625	0.961

### *Common method bias*

Common method bias arises from common method variance caused by the method used to collect data and not by the constructs themselves. Common method variance can cause confounding influences that can lead to incorrect conclusions (Ketchen & Berch, 2006). In order to identify the risk of bias the CFA underwent common method bias testing using Harman's single factor test and the common latent factor process (Ketchen & Berch, 2006). Harman's single factor test involved performing an exploratory factor analysis within SPSS<sup>®</sup>. The first variable explained 48.6% of the total variance as presented in Table 50.

**Table 50: Total variance explained**

Component	Initial Eigenvalues		Extraction Sums of Squared Loadings	
	Total	% of Variance	Total	% of Variance
1	10.675	46.415	10.675	46.415
2	2.277	9.899	2.277	9.899
3	1.521	6.612	1.521	6.612
4	1.210	5.262	1.210	5.262
5	.925	4.020	.925	4.020
6	.738	3.210	.738	3.210

Extraction Method: Principal Component Analysis.

- a. When components are correlated, sums of squared loadings cannot be added to obtain a total variance.

Since the first factor explained a majority of variance, common method bias is likely (Loser, 2015). The common method factor was used as a second measure of bias. A common method variable was added to the model and examined when constrained and unconstrained. The constrained model had better fit indices than those of the unconstrained model which shows that common method bias is likely (Ketchen & Berch, 2006). Due to this the variables in the model were common method adjusted. To overcome this a same source factor was added to the indicators of all constructs within the model. This was carried through into the SEM analysis (Ketchen & Berch, 2006).

## **INITIAL HYPOTHESISED STRUCTURAL EQUATION MODEL TESTING THE RELATIONSHIP BETWEEN COMMUNICATION SATISFACTION ON JOB SATISFACTION AND INTENTION TO STAY**

The SEM analysis were undertaken using the software package AMOS 23.0<sup>®</sup>. Based on the CFA, each of the latent variables were given a parcelled mean score, which replaced the individual scores in the SEM analysis. The hypothesised model underwent maximum likelihood estimation (MLE) to evaluate the goodness of fit. Several fit indices were used to report the goodness of fit between the hypothesised model and the observed data (Kline, 2005), namely; Chi-Square, Standardised Root Mean Square Residual (SRMR), Comparative Fit Index (CFI), Root Mean Square Error of Approximation (RMSEA) and pCLOSE. Figure 43 illustrates the initial hypothesised SEM of the effects of communication satisfaction on paediatric ward nurses' job satisfaction and intention to stay in their current job.

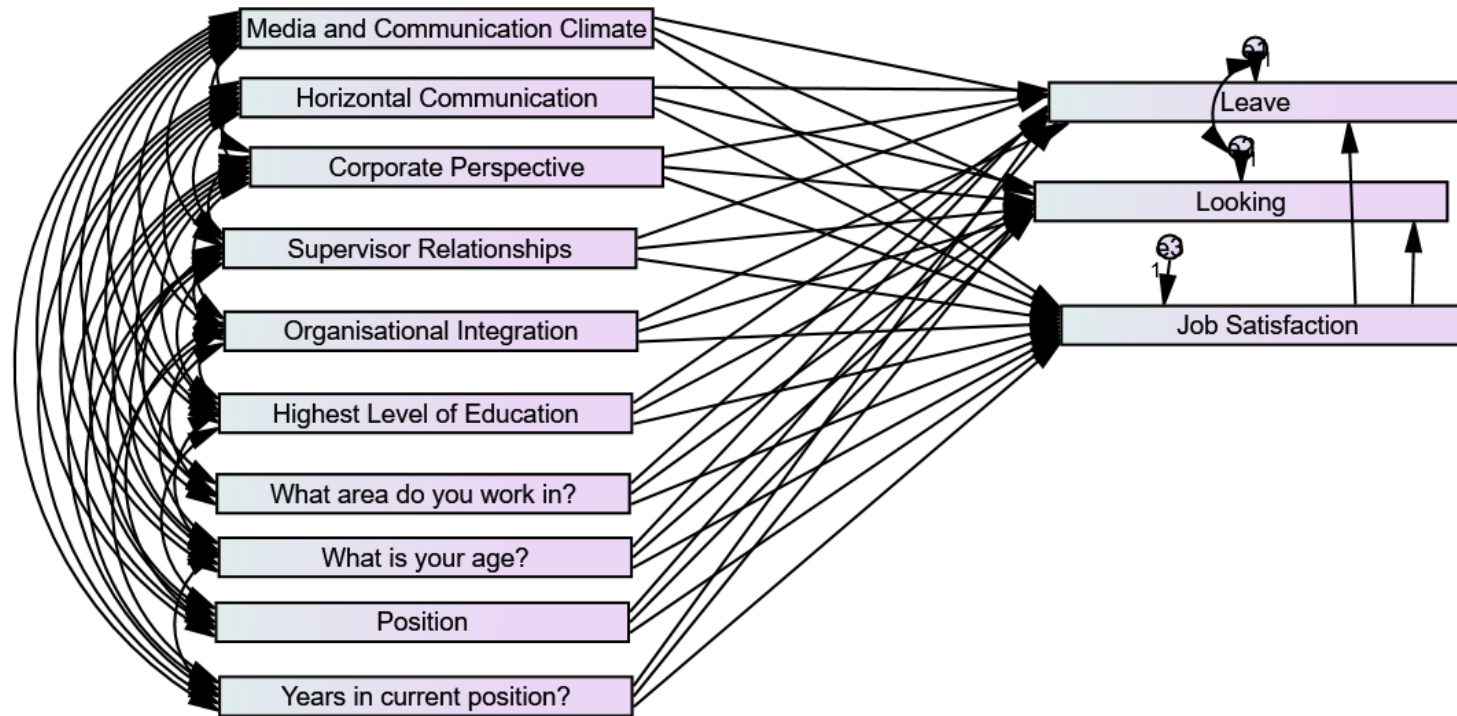

Note:  $\chi^2 = 4.939$ , p value = .667, CFI= 1.00, RMSEA= .000, pCLOSE= .819, SRMR= .0222

**Figure 43: Initial hypothesised Structural Equation Model of the effects of communication satisfaction on paediatric nurses' job satisfaction and intention to stay**

The initial hypothesised model indicated adequate fit. Following analysis of the initial hypothesised model, the insignificant pathways were removed. Figure 44 shows the model with significant pathways. The non-significant pathways in the model are shown in dotted lines.

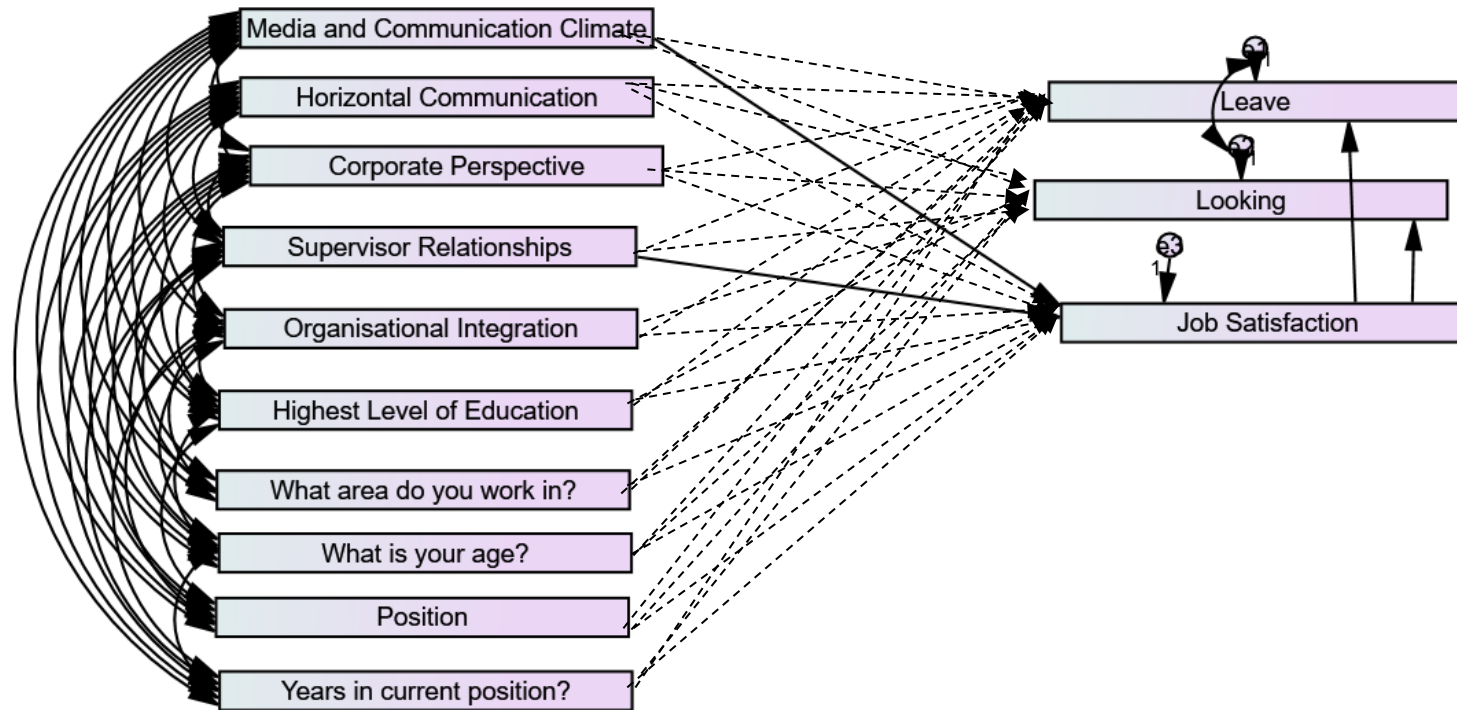

Note:  $\chi^2= 27.761$ , p value= .803, CFI=1.00, RMSEA= .000, pCLOSE= .974, SRMR= .0513

**Figure 44: Initial hypothesised model with significant and non-significant pathways**



Table 51 shows the significance statistics for the model. Supervisor relationships is positively and significantly related to job satisfaction ( $b=.259$ ,  $p=.001$ ). Media and communication climate are positively and significantly related to job satisfaction ( $b=.680$ ,  $p=.002$ ). Job satisfaction is negatively and significantly related to paediatric nurses wanting to leave their job and the nursing profession ( $b=-.227$ ,  $p=.032$ ) and negatively and significantly related to looking for another job ( $b=-.208$ ,  $p=.001$ ).

**Table 51: Significant statistics for hypothesised SEM**

			<b>Estimate</b>	<b>S.E.</b>	<b>C.R.</b>	<b>P</b>
Job satisfaction	<---	Media and Communication Climate	.680	.221	3.077	.002
Job satisfaction	<---	Supervisor	.259	.080	3.226	.001
Leave	<---	JOBSAT_MEAN	-.227	.106	-2.143	.032
Looking	<---	JOBSAT_MEAN	-.208	.063	-3.317	***

Note: P value significant at the .05 level, \*\*\*= significant at the .001 level

### **Final Structural Equation Model of the effects of communication satisfaction on paediatric nurses' job satisfaction and intention to stay**

The non-significant pathways were deleted from the final SEM. Figure 45 illustrates the final hypothesised SEM.

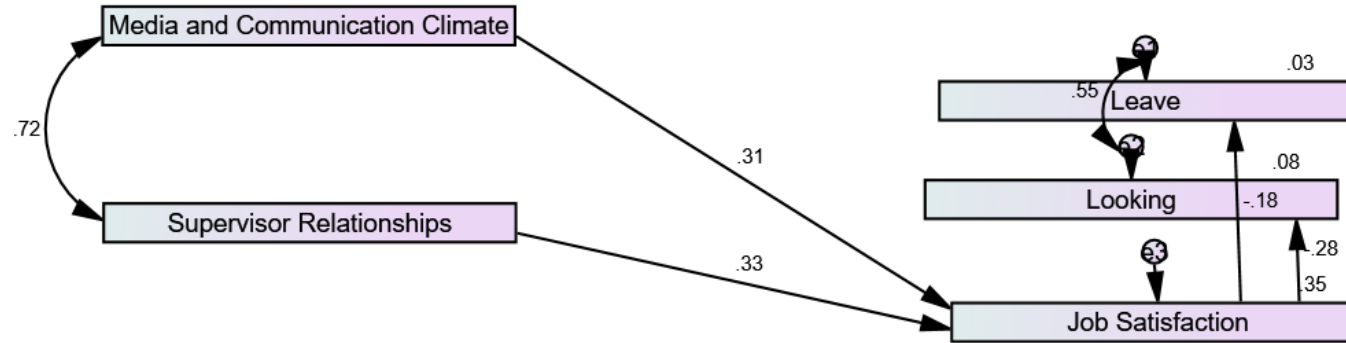

Note.  $\chi^2= 2.040$ , p value= .728, CFI=1.00, RMSEA=.000, pCLOSE= .827, SRMR= .0302

**Figure 45: Final Structural Equation Model of the effects of communication satisfaction on paediatric nurses' job satisfaction and intention to stay with standardised path coefficient and deletion of non-significant pathways**

## **ALTERNATIVE HYPOTHESISED STRUCTURAL MODEL**

Kline (2005), suggests after a final model is selected that at least one plausible alternative model be measured. Inversion in the causal model of two adjacent constructs will offer a unique theoretical perspective whilst still generating the same covariance matrix (Stelzl, 1986). In this study the pathway for job satisfaction and intention to leave were inverted. The alternative hypothesised model illustrates that intention to leave and looking for a new job has a direct effect on a paediatric nurses' job satisfaction. The alternative structural model is illustrated in Figure 46.

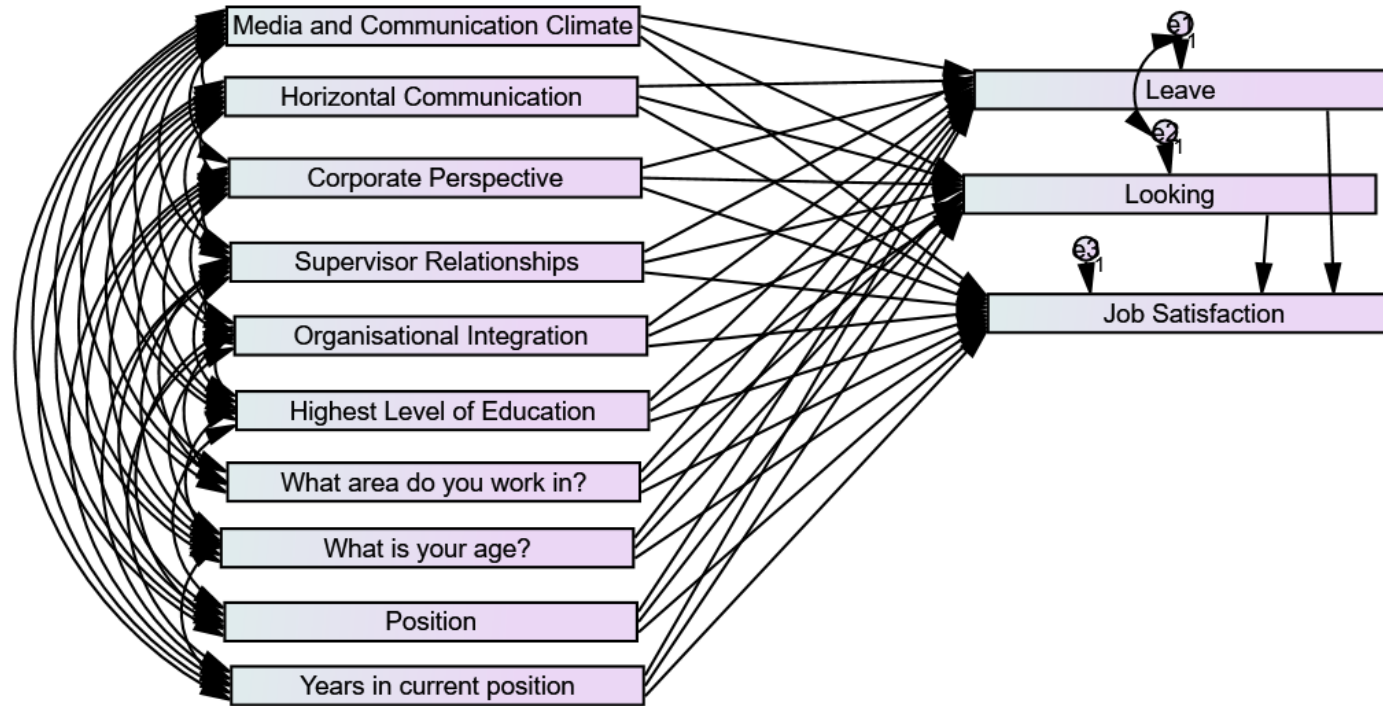

Note:  $\chi^2= 4.939$ , p value= .667, CFI=1.00, RMSEA=.000, pCLOSE= .819, SRMR=.0222

**Figure 46: Initial Iterative hypothesised Structural Equation Model of the effects of paediatric nurses' communication satisfaction on job satisfaction and intention to stay**

The initial alternative hypothesised model showed good fit. The alternative structural model with significant and non-significant pathways is presented in Figure 47. The non-significant pathways in the model are shown in dotted lines.

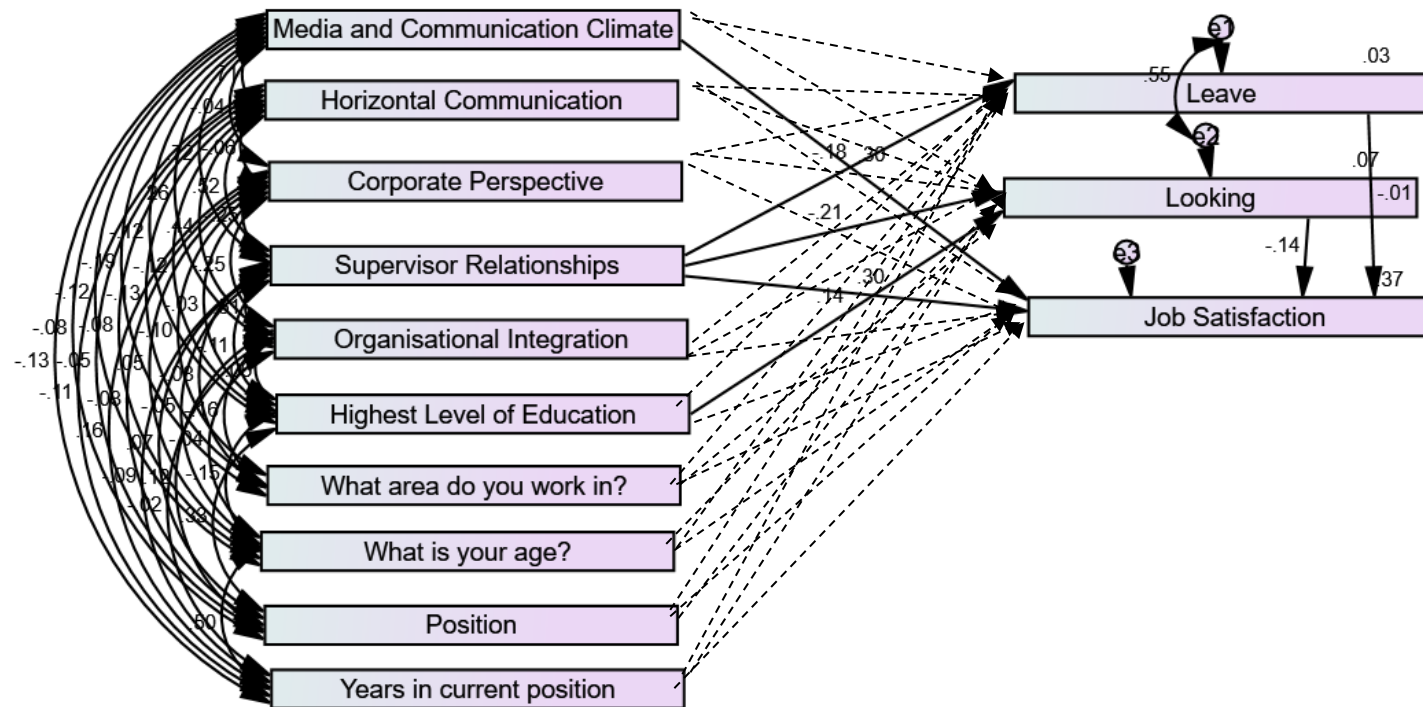

Note:  $\chi^2= 23.071$ , p value=.901, CFI=1.00, RMSEA= .000, pCLOSE= .990, SRMR= .0460

**Figure 47: Alternative significance model with significant and non-significant pathways**

Table 52 shows the significance statistics for the model. Supervisor relationships is significant to the .05 level on job satisfaction and looking for a new job and significant to the .05 level on leaving their job. Media and communication climate is significant at the .05 level on job satisfaction.

**Table 52: Significance statistics for the alternative SEM**

			<b>Estimate</b>	<b>S.E.</b>	<b>C.R.</b>	<b>P</b>
Looking	<---	Supervisor	-.122	.050	-2.449	.014
Looking	<---	Highest Level of Education	.040	.019	2.035	.042
JOBSAT_MEAN	<---	Supervisor	.242	.080	3.021	.003
JOBSAT_MEAN	<---	Looking	-.202	.096	-2.093	.036
Leave	<---	Supervisor	-.174	.084	-2.068	.039
JOBSAT_MEAN	<---	Combined	.646	.219	2.955	.003

Note: p values are significant at the .05 level

### **Alternative final model**

The non-significant pathways were deleted from the final SEM. The goodness of fit statistics showed adequate model fit. Figure 48 illustrates the final alternative SEM.

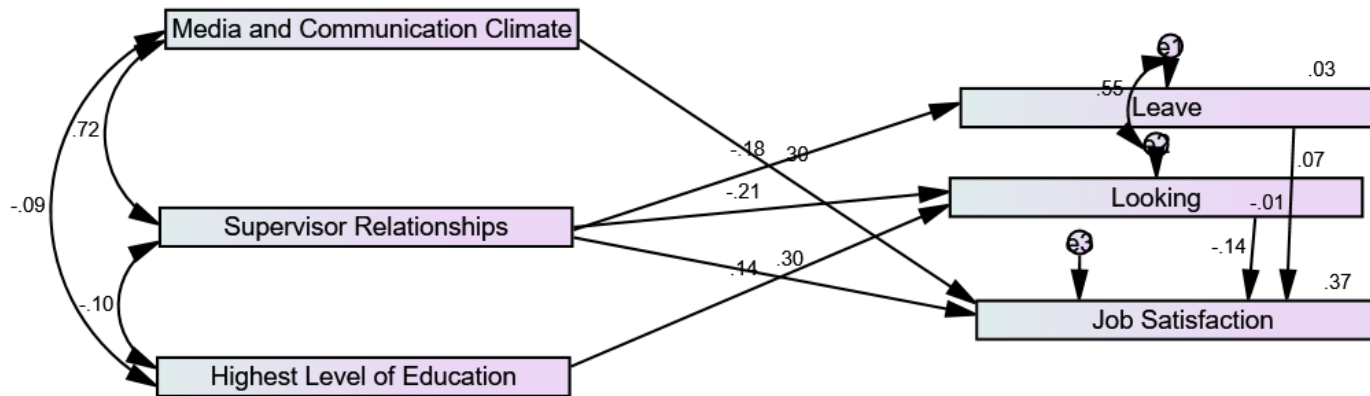

Note.  $\chi^2=2.899$ , p value =.575, CFI=1.00, RMSEA=.000, pCLOSE=.711, SRMR=.0290

**Figure 48: Final alternative Structural Equation Model of the effects of communication satisfaction on paediatric nurses' job satisfaction and intention to stay with standardised path coefficient and deletion of non-significant pathways**

## COMPARISON OF MODELS

The hypothesised model was the preferred model for several reasons. Firstly, the model is more robust with the relationship between job satisfaction and intention to leave significant at the .05 level. This is in keeping with previous research, where job satisfaction has been found to be a determinant of intention to stay and turnover intention (Jasper, 2007; Ma et al., 2003). Also, examining the goodness of fit indices the chi-square is a lower value (2.040 as compared to 2.899) a higher p value (.728 as compared to .575) and a higher pCLOSE value of .827 (compared to .711) which indicates a better fit, whilst SRMR is higher in the hypothesised model it is still below .05 which still represents a good model fit. The goodness of fit statistics is presented in Table 53. The final SEM is presented in Figure 49.

*Table 53: Comparison of final theoretical model and alternative final model*

Model	$\chi^2$ (df)	P value	CFI	RMSEA (CI)	SRMR	pCLOSE	MI (Par change)
Hypothesised final model Figure 33	2.040(4)	.728	1.00	.000(.000-.096)	.0302	.827	Nil
Alternative model Figure 36	2.899(4)	.575	1.00	.000(.000-.114)	.0290	.711	Nil

Note: Goodness of fit is indicated by p value >.05, SRMR <.05, CFI >.95, RMSEA <.05, pCLOSE >.05



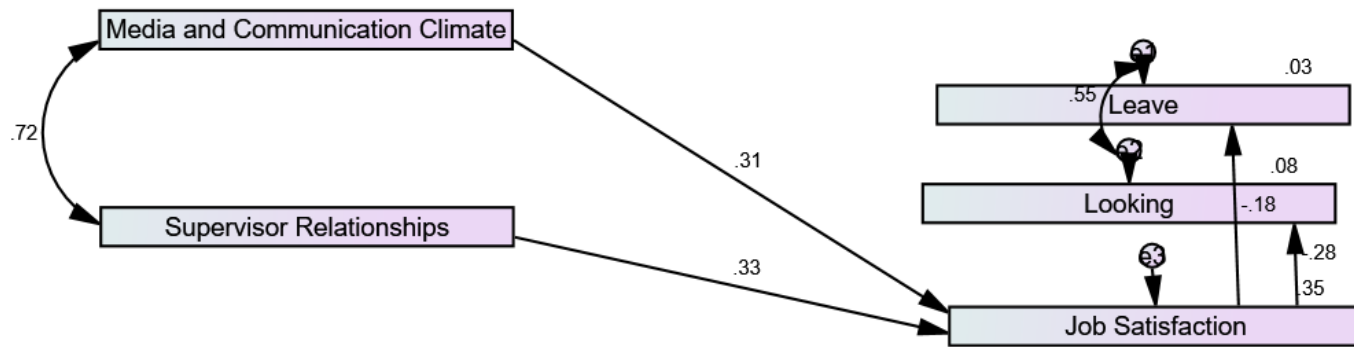

Note.  $\chi^2=2.040$ , p value=.728, SRMR=.0302, CFI=1.00 RMSEA=.000, pCLOSE=.827

**Figure 49: Final Structural Equation Model for paediatric nurses' communication satisfaction and the effect on job satisfaction and intention to stay**

## EFFECTS OF FINAL MODEL

The standardised direct, indirect and total estimates were calculated for the final SEM. The standardised direct effect is the immediate relationship between two variables. An indirect effect reflects the effects of a prior independent variable on a subsequent dependent variable and is the direct path coefficient. The total effect is the sum of the direct and indirect effects (Kline, 2005). Standardised path estimates with a value greater than .50 are considered to have a large effect, values between .30 and .50 have a medium effect and values between .20 and .30 are considered to have small effects. Value less than .20 are considered to have weak or non-existent effect (Chin, 1998).

In the final model, supervisor relationship had a medium effect on job satisfaction, a weak negative effect on leave and on looking for another job. Media and communication climate had a large effect on job satisfaction and a weak effect on looking for a new job and leaving the nursing profession. Job satisfaction had a medium negative effect on looking for a new job and intention to stay. Table 54 provides a summary of standardised effects for the final model.

**Table 54: Final model variable's standardised effects (total, direct, indirect)**

	<b>Media/Communication Climate</b>	<b>Supervisor Relationship</b>	<b>Job satisfaction</b>
Looking	-.142 (--/-.142)	-.054 (--/-.054)	-.208 (-.208/--)
Leave	-.155 (--/-.155)	-.059 (--/-.059)	-.227 (-.227/--)
Job Satisfaction	.680 (.680/--)	.259 (.259/--)	-- (--/--)

Note: Direct and indirect effects are showed in parentheses (direct/indirect) below the total effect

## JOB SATISFACTION SEM

A SEM was conducted to test the hypothesis that job satisfaction affects intention to stay. Figure 50 illustrates the initial job satisfaction SEM. The controls of position (Wang et al., 2012), age (Gurková et al., 2013; Ma et al., 2003; Wang et al., 2012) and years in position (Gurková et al., 2013) have been included in the model based on previous research. The model showed adequate goodness of fit ( $\chi^2=6.662$ , p value=.573, SRMR=.565, CFI=1.0, RMSEA= .000 and pCLOSE=.764). There were no modification

indices resulting from the CFA. As the aim of this model was to identify the significance in the relationship between job satisfaction and intention to stay and looking for another job no further modifications were made to the model. Job satisfaction was significant on looking for a new job at the .001 level and .05 level for wanting to leave their job (See Table 55). The controls age, position and years in position were not significant within the model.

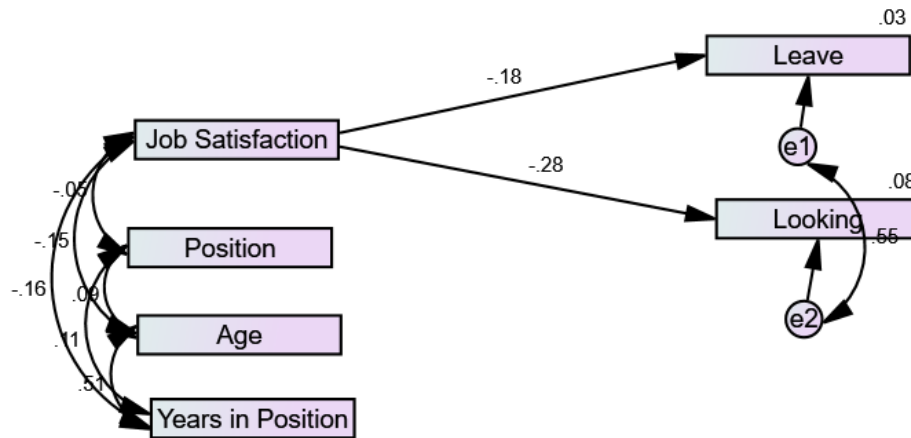

Note:  $\chi^2=6.662$ , p value=.573, SRMR=.565, CFI=1.0, RMSEA= .000 and pCLOSE=.764

**Figure 50: Initial hypothesised SEM for job satisfaction and intention to stay**

**Table 55: Significance statistics for job satisfaction**

			Estimate	S.E.	C.R.	P
Leave	<---	Job Satisfaction	-.227	.106	-2.143	.032
Looking	<---	Job Satisfaction	-.208	.063	-3.317	***

Note: \*\*\* shows p value .001 significance level, all other are at significant at the .005 level

## POST HOC INTERACTION MODEL ANALYSIS

The assumption in a statistical model is that the effect of an independent variable on the dependent variable is invariant on any other independent variable in the model. Therefore, the independent variable is assumed to be at the same level for each independent variable within a model. However, an interaction effect occurs when a third variable (moderator  $x_1$ ), affects the relationship between the independent ( $x_2$ ) and dependent variables (Y). An interaction effect is identified when the size and direction of the independent variable changes significantly at different moderator values. Both

categorical and continuous variables can be used in an interaction model (Mehmetoglu & Jakobsen, 2017). The PROCESS macro for SPSS, published by Hayes (2012), was used for the interaction analysis in which a path analysis framework is calculated. Relationships that were identified to be significant in PROCESS were illustrated in a graph using the syntax function in SPSS before being illustrated in a Microsoft Excel® spreadsheet. There were three significant interactions within the hypothesised model which will be discussed.

### **Interaction model for the moderator variable years in position, on horizontal communication and job satisfaction**

To illustrate the moderating effects, the moderating terms are graphically displayed in Figure 51. The regression weights associated with horizontal communication and years in position were examined at one standard deviation below the mean, the mean level, and one standard deviation above the mean using procedures recommended by Hayes (2012). Examination of the interaction plot shows that as the amount of horizontal communication and the number of years in the position increases, job satisfaction increases. Respondents who reported high number of years in position and low levels of horizontal communication had the lowest levels of job satisfaction. At the limited number of years in position, even with lower horizontal communication, job satisfaction increased. However, there was almost no difference in the level of job satisfaction among the number of years in position with high horizontal communication levels.

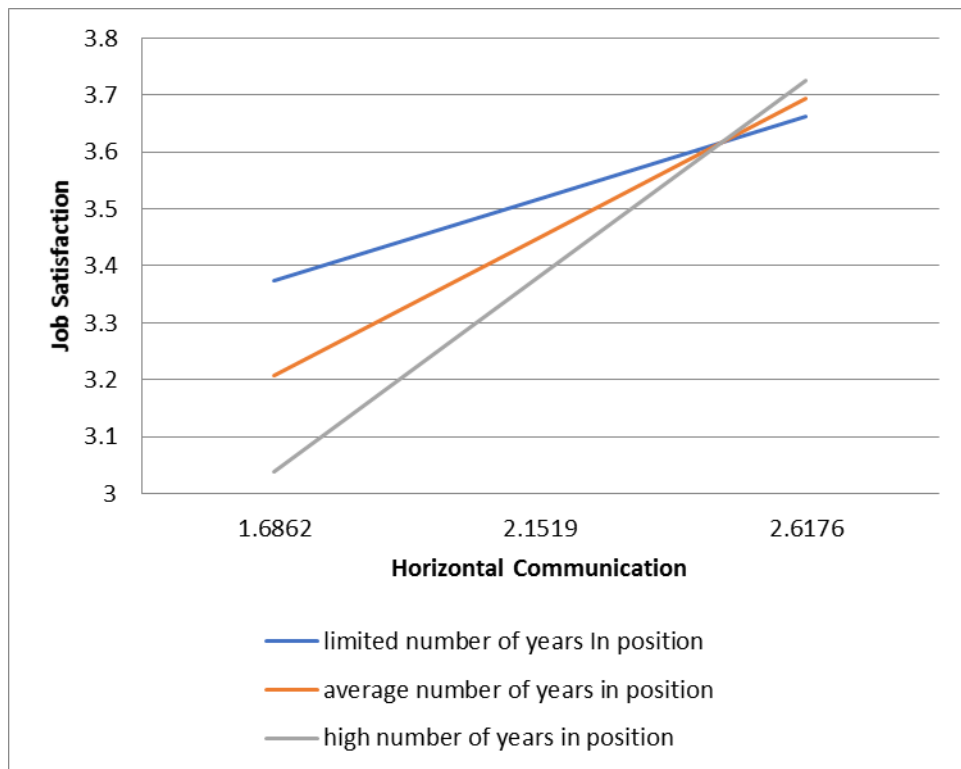

*Figure 51: Moderating effects of years in position on horizontal communication and job satisfaction*

### **Interaction model for the moderator variable age, on horizontal communication and job satisfaction**

To illustrate the moderating effects, the moderating terms are graphically displayed in Figure 52. The regression weights associated with horizontal communication and age were examined at one standard deviation below the mean, the mean level, and one standard deviation above the mean using procedures recommended by Hayes (2012). Examination of the interaction plot shows that as the amount of horizontal communication and respondents age increases, job satisfaction increases. Respondents who reported younger age and low levels of horizontal communication had the highest levels of job satisfaction. Older respondents who had low levels of horizontal communication had the lowest level of job satisfaction. There was almost no difference in the level of job satisfaction among the different ages with high levels of horizontal communication.

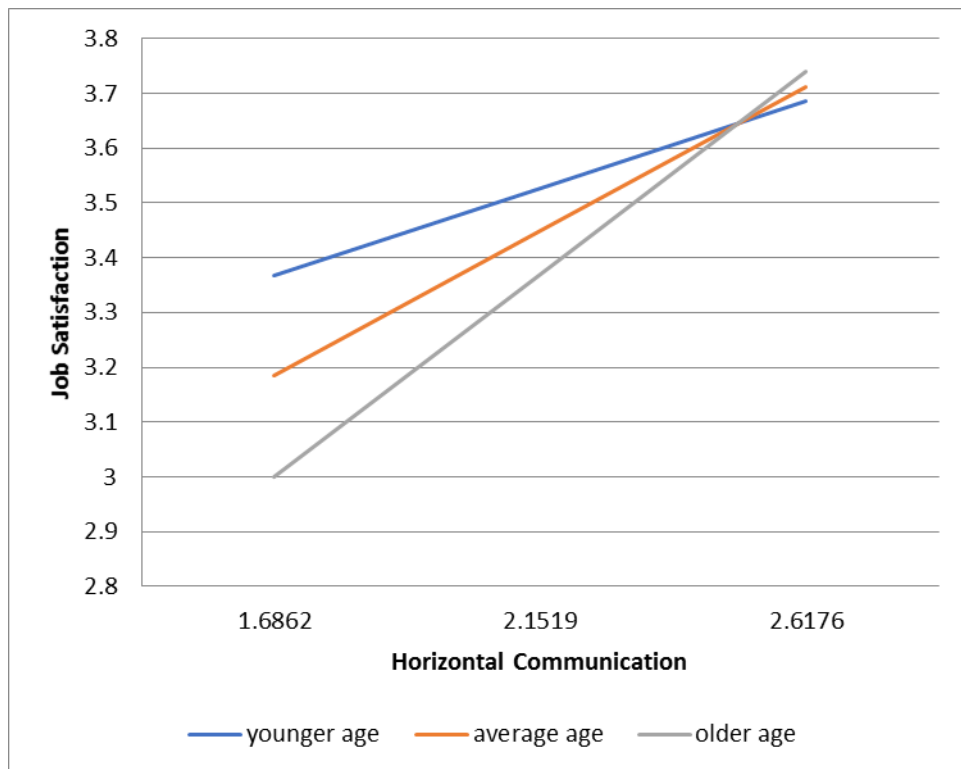

*Figure 52: Moderating effects of age on horizontal communication and job satisfaction*

### **Interaction model for the moderator variable job position, on horizontal communication and job satisfaction**

To illustrate the moderating effects, the moderating terms are graphically displayed in Figure 53. The regression weights associated with organisational integration and job position were examined at one standard deviation below the mean, the mean level, and one standard deviation above the mean using procedures recommended by Hayes (2012). Examination of the interaction plot shows that as the amount of organisational integration increases and respondents job position increases, job satisfaction decreases. Respondent in low job positions with high levels of organisational integration have greater job satisfaction levels than respondents in high job positions. Respondents with low organisational integration and low job positions had the lowest levels of job satisfaction. However, there was almost no difference in the level of job satisfaction among the different job positions with low levels of organisational integration.



**Figure 53: Moderating effects of job position on organisational integration and job satisfaction**

## HYPOTHESIS TESTING

Table 56 shows the directional hypotheses, overarching hypotheses and interaction hypothesis that were supported for the study. The terms positive and negative were used for the directional hypotheses to anticipate the relationship. In a positive relationship, as one variable increases, the other increases, and as one variable decreases the other variable decreases. In contrast, in a negative or inverse relationship, the two variables move in opposite directions i.e. As one variable increases the other variable decreases (Le Roy, 2013).

**Table 56: Summary of supported hypotheses**

Hypothesis	Supported/Not Supported
<i>Job satisfaction</i>	
H11 - Supervisor relationships are positively related to paediatric nurses' job satisfaction	Supported
H12 - Media is positively related to paediatric nurses' job satisfaction	Supported
H13 - Communication climate is positively related to paediatric nurses' job satisfaction	Supported
H22 - The more satisfied paediatric nurses are with organisational communication, the less likely they are to be looking for another job	Supported

H23 - The more satisfied paediatric nurses are in their job, the less likely they are to leave their job, and the less likely they are to be looking for a new job	Supported
<i>Interaction hypothesis</i>	
H24 - Years in position strengthens the positive relationships between horizontal communication and job satisfaction	Supported
H25 - Age strengthens the positive relationship between horizontal communication and job satisfaction	Supported
H26 - Job position dampens the positive relationship between organisational communication and job satisfaction	Supported

## SUMMARY

This chapter presented the results from the SEM analysis. Prior to testing the hypothesised model, the communication satisfaction questionnaire was subjected to Congeneric Factor Analysis, to identify the extent to which each item was a valid measure of its construct. Following the Congeneric Factor Analysis, a CFA was conducted. This resulted in media and communication climate needing to be joined together as one variable through higher factor analysis. The instrument demonstrated acceptable internal consistency before and after measurement model evaluation.

Model fit was assessed using chi-squared ( $\chi^2$ ), SRMR, CFI, RMSEA and pCLOSE indices. The final study models showed good model fit which supports eight hypotheses. Chapter 6 will present the discussion, recommendation and conclusions from the results of the study.



---

# CHAPTER 6: DISCUSSION, IMPLICATIONS AND CONCLUSIONS

## INTRODUCTION

Effective organisational communication is the most central process within an organisation and is essential when developing organisational values, norms and expectations (Harber & Ashkanasy, 1998), and there is a well-documented connection between job satisfaction, work commitment and organisational communication (Amos et al., 2005; Brooks, 2002; Keyton, 2005). However, nurses' and middle managers' satisfaction with organisational communication has not been studied extensively in recent years and more specifically, there is a paucity of evidence in relation to paediatric nurses' job satisfaction and intention to stay in their current job. The purpose of this study was to address this gap by exploring the effect that paediatric nurses' organisational communication satisfaction has on their job satisfaction and intention to stay in their current job. As well as providing the opportunity to add the body of knowledge on this topic more generally, the additional and more urgent driver for the study reported in this thesis was the predicted impending significant shortage of nurses in Australia and the need to understand what health care organisations must provide to encourage paediatric nurses to stay in their jobs.

This chapter provides an interpretation of the study findings and the relationships with previously developed knowledge. The chapter will first discuss an overview of organisational communication satisfaction at the study site. Following this, a discussion of the final theoretical models from the SEM analysis will be provided including direct, indirect, non-significant and deleted determinants of job satisfaction, intention to stay and looking for another job in nursing. Generalisability of study will also be discussed including the practical implications for nursing, education, leadership and research with the chapter concluding with a description of study recommendations, limitations and a summary of final conclusions.

## **OVERVIEW OF ORGANISATIONAL COMMUNICATION AND JOB SATISFACTION AND PAEDIATRIC NURSES' INTENTION TO LEAVE THEIR JOB AND THE NURSING PROFESSION AND LOOKING FOR ANOTHER JOB**

In the present study, communication satisfaction was defined as the level of satisfaction an employee has between the flow of communication and organisational variables (Kandlousi et al., 2010). The paediatric nurses' and middle managers' communication satisfaction was measured according to their perception of horizontal communication, communication climate, media quality, organisational integration, supervisor relationships and corporate perspective.

In this study, the ward nurses and middle manager respondents reported a relatively average score of organisational communication satisfaction. However, when the average responses to each of the communication satisfaction questions were assessed, the middle managers were significantly more dissatisfied with:

- 1) Information about my progress in my job
- 2) Extent to which my supervisor listens and pays attention to me
- 3) Extent to which my supervisor offers guidance for solving job related problems
- 4) Extent to which the amount of supervision given me is about right
- 5) Extent to which the people in my organisation have great ability as communicators
- 6) Extent to which informal communication is accurate and active
- 7) Extent to which the attitudes toward communication in the organisation are basically healthy.

These results might indicate that middle managers are effectively managing ongoing operations, communicating with upper management, communicating with their peers and maintaining communication lines with their direct reports (Awad et al., 2005), whereas communication within the management cohort itself needs to be improved (Tourish & Hargie, 1996). This is further supported by the notion that empowerment for middle managers is positively related to organisational support. Thus, organisational support for middle managers, by providing necessary resources is clearly important for

maintaining the nursing voice (Patrick & Laschinger, 2006) and for promoting effective organisational communication.

Middle management dissatisfaction with communication may also be noted due to the turnover of senior management during the course of this study. Interestingly the Nursing Standard conducted an investigation into nursing management within 200 NHS Trusts and found that most managers had been in the position for three years or less. This high turnover of management was attributed to by the pressure and lack of support (Osborne, 2014). In the nursing home environment, management turnover is linked to staff turnover and poor quality of care (Hunt, Corazzini, & Anderson, 2014). Duffield and colleagues (2011) addressed the gap in the literature by using an example from the Australian public hospital context. In the healthcare setting in Australia, executive turnover is high with 41 executives occupying 18 positions over a period of two years. Factors such as age, gender, education, lack of career advancement and remuneration were found to be important contributors of high executive turnover (Duffield, Roche, Blay, Thoms, & Stasa, 2011). However, there is limited published literature exploring nursing middle management in Australia. Therefore, future research should focus on the causes of turnover rates among the middle manager cohort and mechanisms by which turnover rates can be reduced.

It was apparent that paediatric nurses and middle managers with a master's degree and graduate certificate had lower communication satisfaction averages than paediatric nurses and middle managers with other educational levels. This is similar to a study conducted by Tourish and Mulholland (1997) who found higher grade nurses to be more dissatisfied with communication between nurses and nurse managers. Again, owing to the limited literature comparing communication between paediatric nurses and middle managers further research should focus on educational level and the impact this has on communication perception between paediatric nurses and managers to allow for identification of up to date mechanisms that can strengthen communication channels.

In this present study, paediatric nurses and middle managers with 5-6 years and 9-10 years of nursing and managerial experience had lower average communication satisfaction values than paediatric nurses and middle managers with other levels of nursing and managerial experience. Interestingly, Kaitelidou and colleagues (2012) identified that paediatric nurses who worked in a hospital for 10 years or more felt they would be more satisfied and productive in a different profession compared to colleagues who had 0-2 years in the hospital environment. In addition, paediatric nurses and middle

managers in the 18-29 year old group had higher communication satisfaction median values than that of other age groups. This is in keeping with a study conducted in the United Kingdom that assessed the communication between nurses and nurse managers and highlighted staff under 30 to be less affected by communication than older staff (Tourish & Mulholland, 1997). Further research exploring years of experience and the relationship to communication satisfaction levels is warranted.

In this study, paediatric nurses and middle managers that worked part time had lower average communication satisfaction values than paediatric nurses and middle managers that worked full time and casual hours. These results are comparable to a study conducted in Queensland, where a culture of marginalisation was found to exist for casual and part time nurses. It was found that this marginalisation affected communication for nurses and had implications for patient safety (Batch, 2012). The higher communication satisfaction among casual staff members, in this present study, may be related to the limited number of nurses representing the casual nurse population within the sample.

It is surprising that part time nurses had lower communication satisfaction scores in this present study as middle managers indicated that important information and meeting minutes were emailed and printed off for part time staff members. For example in field notes taken, one middle manager described communication with staff in the following way: *“We are the ham in the communication sandwich and nursing is really difficult to get all of the staff together to discuss things and have a meeting. If it was any other industry they say we are meeting at this time, but not with nursing as it is a 24 hours 7 days a week business. I try to send email updates and do newsletters so staff stay up to date with what is going on, especially part time staff. The newsletters are done weekly and are available for those who don’t have computer access”*. Another manager went further stating that nurses do not acknowledge information either, stating *“I sent out information in emails, newsletters and place them on the wards and they think it is not relevant to them. One nurse asked in a meeting who is this (referring to a person of discussion). The manager responded by saying it’s the nurse who is on all the forms, the one that you need to take note of. Only then did she take note. Some nurses want to do the bare minimum and not participate in the life of the ward. They have no professional responsibility to take note and to be accountable”*. It is unknown whether these results are related to the complex relationship between communication and attitudes (Eisenberg & Witten, 1987) or individual perceptions of communication that

influence participation in decision making, frequency of communication and disclosure (Falcione, Sussman, & Herden, 1987). Future research is needed to explore the relationships between communication and individual attitudes to further tease out the relationships between these concepts and identify appropriate mechanisms for improvement, particularly for part time staff.

The next section will discuss the final models from the SEM as well as determinants of intention to stay and job satisfaction including direct, indirect, non-significant and deleted determinants against relevant literature. It is apparent through searching the literature that there is limited information exploring nurses' or more specifically paediatric nurses' organisational communication satisfaction and the impact this has on their job satisfaction, intention to leave and looking for another job in the last decade.

## **DISCUSSION OF THE FINAL THEORETICAL MODEL TESTING THE RELATIONSHIP BETWEEN COMMUNICATION SATISFACTION ON JOB SATISFACTION AND INTENTION TO STAY**

The final theoretical model provided evidence that paediatric nurses job satisfaction, intention to leave their current job and looking for another job were determined by the attributes of media quality, communication climate, and supervisor relationships.

The results of the SEM<sup>®</sup> analysis indicated that the original hypothesised model had adequate model fit indices requiring no additional pathways to be included in the analysis. Overall, eight out of 26 hypotheses were supported.

In the final model, media quality and communication climate had the strongest total effect on paediatric nurses job satisfaction and a small negative total effect on both intention to leave their current job and looking for another job. Job satisfaction had a small negative total effect on both paediatric nurses intention to leave their current job followed by looking for another job. Supervisor relationship has a small total effect on paediatric nurses job satisfaction, looking for another job and intention to leave their current job. Regarding direct predictors on job satisfaction, media quality and communication climate had the strongest positive direct effect followed by supervisor relationships. These results are similar to a nursing study conducted by Pincus (1986),

where supervisor communication and communication climate were found to be most strongly related to job satisfaction. In this present study, both looking for another job and intention to leave their current job had a small negative direct effect on job satisfaction. Indirect predictors of looking for another job and intention to leave current job, showed a small negative indirect effect with media quality and communication climate and a weak indirect effect with supervisor relationships. Horizontal communication, corporate perspective, organisational integration and the controls, highest level of education, area of work, age, position and years in the role were not significant predictors of job satisfaction, intention to leave their job and looking for another job.

### **Direct determinants of job satisfaction**

There is no paediatric nursing literature that explores communication satisfaction and its impact on job satisfaction, intention to stay and looking for another job. However, parallels to general nurse population and organisational research will be made.

#### *Supervisor relationships*

Supervisor relationships refer to both upwards and downwards aspects of communicating with superiors (Clampitt & Downs, 1993). Organisations that do not utilise upward communication effectively, including the use of both positive and negative comments, can reduce the effectiveness and the quality of the decisions made by top management (Tourish & Robson, 2004). Further to this, upward and downward communication lines can be distorted (Tourish & Robson, 2004) or information withheld or manipulated (Jones, 2004) to deny fault, to avert blame for negative organisational outcomes and negative financial data and to deny failure, feedback can be suppressed (Abrahamson & Park, 1994; Ashforth & Gibbs, 1990; Sutton & Callahan, 1987). This results in disadvantages for the team and the organisation as a whole.

In the final model supervisor relationships were found to have a positive significant effect on paediatric nurses' job satisfaction. Similarly, previous research has reported that supervisor relationships impact on nurses' job satisfaction (Frone & Major, 1988; Pincus, 1986; Spence-Laschinger et al., 2007; Tourish & Hargie, 1996; Varona, 1996). Nursing leaders that are highly visible, responsive and offer support for clinical nurses improve job satisfaction of their subordinates (Upendicks, 2002). Likewise, higher quality relationships with supervisors were associated with greater

manager structure and psychological empowerment as well as greater job satisfaction (Spence-Laschinger et al., 2007). However in Australia, nurses have been found to be dissatisfied with organisational relationships, the amount of information being received and the length of time for communications to take place (Braff et al., 2012).

Additionally, a lack of vision, values and direction, lack of or ineffective meetings, lack of consultation and feedback, lack of senior/middle management visibility around the workplace, the need for more face-to-face communication, lack of resources including staff, equipment and information, need for improvement in both top-down or bottom-up communication and unclear reporting lines, have all resulted in communication difficulties for Australian nurses (Horsley, 1996). This is similar to studies conducted in Lebanon (Kaddourah et al., 2013), United States of America (Feather et al., 2015) and the United Kingdom (Tourish & Hargie, 1996; Tourish & Mulholland, 1997).

In addition, when nurses feel that management are not sharing, are withholding information or the formal channels of communication are dysfunctional, gossip or grapevines can result. This allows nurses to attain information that they feel is not readily available to them. (Atak, 2005; Harber & Ashkanasy, 1998; Houmanfar & Johnson, 2004). Unfortunately, gossip, when not handled well, can result in demoralised workers, unrest, apathy (Houmanfar & Johnson, 2004) and may result in decreased productivity and nurses wanting to leave their jobs (Altuntas, Altun, & Akyil, 2014). Therefore, nurse leaders need to assess the efficacy of the upward and downward communication and feedback to improve supervisor relationships. In addition, formal education in professional and personal communication would be of benefit to further strengthen communication channels between management and ward staff.

### *Media quality*

Media quality refers to the extent to which meetings are well-organised, written directives are short and clear, and the degree to which the amount of communication is about right (Clampitt & Downs, 1993). In the final model media quality was shown to have a positive and significant effect on paediatric nurses' job satisfaction jointly with communication satisfaction. Equally, Pincus (1986) noted that media quality had a relatively strong relationship with nurses job satisfaction. In previous research nurses have reported to be dissatisfied with the lack of or ineffective meetings (Horsley, 1996) and want more frequent meetings, with relevant and targeted information presented (Tourish & Hargie, 1996). Further, Chang and Chang (2009) highlighted that effective internal marketing offers good communication channels, establishes good enterprise

culture, and treats nurses cordially as internal customers, which also has the added benefit of increasing personal commitment. Middle managers need to create an environment that promotes effective communication in order to keep staff informed, articulate performance expectations and give feedback.

#### *Communication climate*

Communication climate reflects communication on both the organisational and personal levels. It includes both the extent to which communication motivates and stimulates workers to meet organisational goals, and the extent to which it makes them identify with the organisation. Also, it includes whether or not people's attitudes towards communication are healthy within the organisation (Clampitt & Downs, 1993). In the final model, communication climate was shown to have a positive and significant effect on paediatric nurses' job satisfaction. Likewise, Pincus (1986), noted that communication climate was strongly related to job satisfaction in nurses in a study conducted in the United States of America. Middle managers need to promote a communication environment that promotes positive communication attitudes and promotes nursing input into policy, procedures and problem solving, as a means of strengthening the relationship between nurses and middle managers.

### **Indirect determinants of intention to leave and looking for another job**

#### *Supervisor relationships*

Supervisor relationships within the final model was shown to have a weak negative indirect effect on paediatric nurses intention to leave and looking for another job in nursing. If an employee is not effectively communicated with or actively involved within the decision-making process they become less committed to the organisation in which they work. Therefore, an employee who is satisfied with the quality of supervisor subordinate relationships, employee recognition and involvement (Pincus, 1986), praise and manager practice (Tourangeau & Cranley, 2006), will be committed to their job and the organisation (Adrian & Ticehurst, 2001; Bartels et al., 2010; Becker, 1992; Brunetto et al., 2011; Griffeth, Hom, & Gaertner, 2000; Varona, 1996). In healthcare research, CEO's that facilitated employee voice and upward communication, were approachable, and fostered relationships that enhanced organisational commitment of nurses (Adelman, 2010). Differently, poor relationships can result in low commitment and high turnover intentions, with high absenteeism occurring when nurses are not satisfied with communication with their superiors (Sias,



2005). In light of this, upper management need to have greater visibility and need to strengthen their relationships with nurses in order to improve the lines of communication within the organisation.

#### *Media quality*

In the final model, media quality was found to have a combined weak negative indirect effect on paediatric nurses intention to leave and looking for another job. This finding is similar to a study conducted in a catholic private paediatric hospital in Guatemala, where media quality was found to be a significant predictor of organisational commitment (Varona, 1996). Likewise, internal marketing was associated with an increase in organisational commitment of nurses in Taiwan (Chang & Chang, 2009). Therefore, internal communication needs to be assessed and strengthened in order to reduce the like hood of paediatric nurses intending to leave their positions and looking for another job.

#### *Communication climate*

In the final model, communication climate was found to have combined weak negative indirect effect on paediatric nurses intention to leave and looking for another job. Likewise, Varona (1996) noted that communication climate appeared to be a significant predictor of organisational commitment in a Guatemalan study conducted over three organisations. Therefore, a positive communication climate needs to be formed to promote positive attitudes towards communication within the organisation, in order to improve organisational commitment and reduce the incident of paediatric nurses intending to leave or looking for another job.

### **Non-significant determinants of job satisfaction, intention to leave and looking for another job**

#### *Demographics*

Participant demographics including; age, gender, highest level of education, years of experience, position and area of work did not significantly impact on paediatric nurses job satisfaction, intention to leave or looking for another job, in this present study. This is in contrast to other nursing research, where age (Alexander, Lichtenstein, Oh, & Ullman, 1998; Gurková et al., 2013; Wang et al., 2012), position (Ma et al., 2003), working evening shift and level of job satisfaction were found to influences

nurses' intention to stay (Alexander et al., 1998; Ma, Lee, Yang, & Chang, 2009; Wang et al., 2012). These differences may be noted due to the different demographics of the studies, the dated time period of publication and organisational structures in which the studies were undertaken.

#### *Horizontal communication*

Horizontal communication refers to communication with individuals on the same hierarchical level (Bartels et al., 2010). This type of communication is usually used for task-related and informal communication (Postmes, 2003) and is essential for the coordination and integration of functions within an organisation (Gibson et al., 2009). Effective horizontal communication has also been linked to an individual's professional identification (Bartels et al., 2010), and is essential for high quality patient care, patient satisfaction, collaboration and teamwork (Pearson, 1985; Robertson-Malt & Chapman, 2008).

In the final model, horizontal communication was not found to be significantly related to paediatric nurses job satisfaction, intention to leave one's job and looking for another job. In contrast to this, lateral communication has been identified to be negatively and significantly correlated with job satisfaction (Muchinsky, 1977). Similarly, a study conducted in in three Guatemalan organisations identified horizontal communication as a significant predictor of organisational commitment (Varona, 1996). These differences may be noted due to the different countries, organisational structure and the dated time period in which the studies were conducted.

#### *Corporate perspective*

Corporate perspective reflects the broad elements of the organisation in terms of notifications about changes, information about financial standing, and information about policies and goals (Clampitt & Downs, 1993). In the final model, corporate perspective was found to be a non-significant determinant of paediatric nurses job satisfaction, intention to stay and looking for another job. In contrast, Varona (1996), conducted a study exploring differences between a catholic children's hospital, a catholic school and a food factory, in which corporate perspective was identified to be a significant predictor of commitment. Research has reported that most nurses were dissatisfied with the amount of information they received, with most wanting further dissemination of information on the general work of hospitals and the key management issues which they are faced with (Tourish & Mulholland, 1997). Additionally, research has reported

the invisible nature of senior managers, with nurses feeling excluded from decisions made about their work (Tourish & Hargie, 1996), and the organisation (Feather et al., 2015), resulting in an increase in staff frustrations (Tourish & Hargie, 1996). The differences between these studies and the present study may be noted due to cultural and contextual differences between countries and hospital sites. In addition, these studies were conducted over a decade ago, which may also account for differences and advancements in the structure of healthcare institutions as many hospitals have adopted a decentralised structure as they aspire to magnet status (Erenstein & McCaffrey, 2007).

### *Organisational integration*

Organisational integration reflects the degree to which an individual receives information about their immediate environment, and includes information about job progress, personnel news, benefits and pay, and policies and goals (Downs & Hazen, 1977). In the final model, organisational integration was shown to be a non-significant determinant of paediatric nurses' job satisfaction, intention to leave and looking for another job. This is different to a study conducted by Varona (1996) where organisational integration was identified as the most frequent predictor of commitment. However, they conducted their study across multiple organisations and across different disciplines, which may have accounted for the difference in results between the studies. Also, difference between management styles may explain differences between the results of these studies. Likewise, nurses in a NHS trust felt that they did not receive adequate information about how well they were doing in their job, how they are being judged, and how decisions about their jobs are being made (Tourish & Mulholland, 1997), which resulted in nurses feeling frustrated (Tourish & Hargie, 1996). In order to maintain low level of frustrations, adequate infiltration of information to paediatric nurses would be beneficial to prevent the organisational integration from impacting on communication satisfaction levels.

## **JOB SATISFACTION, INTENTION TO LEAVE AND LOOKING FOR ANOTHER JOB**

In the present study, all 15 items of the job satisfaction survey were rated 'satisfied' by paediatric nurses on the Likert scale. Of the 131 ward nurses 32 (24.4%) were planning to leave in the next year, 38 (29.0%) were looking for another job and 69 (52.7%) felt it would be difficult to find an acceptable job in nursing.

The results of the AMOS<sup>®</sup> analysis indicated that the original model had adequate model fit indices requiring no additional pathways to be included or deleted in the analysis. Job satisfaction showed to have a negative significant relationship with intention to leave one's job and looking for another job in nursing. This is consistent with previous literature where job satisfaction has been linked to nurses' intention to stay (Al-Ma'aitah, Cameron, Armstrong-Stassen, & Horsburg, 1996; Gurková et al., 2013; Hazell, 2010; Price & Mueller, 1981; Ramoo et al., 2013; Strachota, Normandin, O'Brien, Clary, & Krukow, 2003; Wang et al., 2012). Nurses who have high job satisfaction tend to have more work enjoyment (Davidson et al., 1997; Heath, Johanson, & Blake, 2004), and are less likely to express an intention to leave their current jobs (Gerster & Day, 1997; Kaddourah et al., 2013). Therefore, strategies that promote job satisfaction should be disseminated in order to reduce paediatric nurse intention to leave and looking for another job.

The demographics of age, position and years of experience did not have a significant impact on paediatric nurses' job satisfaction in this present study. In nursing in general, Ahmad and Oranye (2010), identified no significant association between demographic characteristics and job satisfaction in two hospitals, one located in the United Kingdom and one in Malaysia. In contrast Ma, Samuels and Alexander (2003) found the demographics of position and years of experience to have a significant impact on job satisfaction. Similarly, nurse education has been identified to have a positive impact on nurse job satisfaction and retention (Janney, Horstman, & Bane, 2001; Ndiwane, 1999), with nurses with a diploma being significantly more satisfied with their job than nurses who had a university degree (Kaddourah et al., 2013). Likewise, age, working evening shift and level of job satisfaction were found to influence nurses' intention to stay (Alexander et al., 1998; Ma et al., 2009; Wang et al., 2012). These differences may be noted due to the nursing context of the studies instead of specifically focusing on paediatric nursing and the dated time period of the studies.

## **INTERACTION MODEL ANALYSIS**

A post hoc interaction model analysis was conducted for this study. An interaction model looks at an interaction effect that occurs when a third variable (moderator  $x_1$ ), affects the relationship between the independent ( $x_2$ ) and dependent variables (Y). An interaction effect is identified when the size and direction of the independent variable changes significantly at different moderator values (Mehmetoglu & Jakobsen, 2017).

Three interaction hypothesis were supported for this study; namely, H24 - Years in position strengthens the positive relationships between horizontal communication and job satisfaction, H25 - Age strengthens the positive relationship between horizontal communication and job satisfaction, and H26 - Position dampens the positive relationship between organisational communication and job satisfaction. This is the first study to analyse interactions between variables exploring nurses satisfaction with organisational communication and the relationship between job satisfaction, intention to leave and looking for another job.

## **GENERALISABILITY OF STUDY FINDINGS**

The survey response rate of 42.4% was in keeping with the expected questionnaire completion rate of 42%-53% in nursing (Aiken et al., 2002), and is similar to studies in the paediatric setting (Adwan, 2014; Ernst, Franco, Messmer, & Gonzalez, 2004). There are studies in the paediatric setting that have a higher response rate of 68% (Suddaby & Josephson, 2013), and 71% (Varona, 1996). However, in these studies the number of nurses in which the surveys were distributed to was relatively low at 96 and 75 nurses respectfully.

### **Study demographics**

#### *Position*

All paediatric nurses and middle managers (including CNM, SRN, CNS, CNC) participated in the communication satisfaction component of the survey. The job satisfaction and intention to stay components of the survey were completed by ward paediatric nurses only and included EN, RN, CN, CDN positions. This inclusion of all nursing personal from different nursing positions is comparable to other studies conducted in paediatric nursing (Akman, Ozturk, Bektas, Ayar, & Armstrong, 2016; Ernst et al., 2004).

#### *Gender and age*

Nursing is a female dominant profession, with only 10% of nurses working in Australia being male (Australian Bureau of Statistics, 2013). Numbers are similar in the United Kingdom and United States of America with 10.2% and 5% respectfully (Needleman et al., 2002; Oxtoby, 2003). In this study, only 5.84% or nine participants

were male. These low numbers of male participants are in keeping with the number of male participants in other paediatric research (Adwan, 2014; Ernst et al., 2004).

The majority of paediatric nurses in this study were aged in the 18-29 year old category. This is similar to results from other paediatric settings (Akman et al., 2016; Ernst et al., 2004). However, a study conducted in the United States of America noted an average age of paediatric nurse participants to be  $34 \pm 10$  years. This slightly higher average may be attributed to by the age of the nursing workforce in United States of America being slightly higher than in Australia. The average American nurse being 47.0 years of age in 2010 (American Association of Colleges of Nursing, 2014), with a survey in 2013 identifying 55% of RNs in United States of America are 50 years of age or older. In contrast, the average age of registered nurses in Australia is 43.4 years of age (Australian Government, 2016).

#### *Highest level of education*

The highest level of education of paediatric nurses in this study was a bachelor degree in nursing. This is consistent with paediatric nurses in a study conducted by Ernst and colleagues (2004), where 50% of the sample had a bachelor degree. Likewise, 70.2% of participants in a study exploring the job satisfaction of paediatric nurses were found to hold a bachelor degree in nursing (Akman et al., 2016).

The majority of middle managers in this present study received a graduate diploma as their highest level of education. Educational level of middle managers in the paediatric setting were not found to be reported on in the studies reviewed.

#### *Employment status*

The majority of paediatric nurses and middle managers in this study worked in a full-time capacity. This is surprising considering the significant levels of casual and part-time employment in the Australian nursing profession, with 49.8% of nurses working less than 35 hours a week. The Australian nursing and midwifery workforce showed that in 2012 an average of 33.2 hours were being carried out by nurses (Australian Government, 2013).

#### *Ward area*

All ward areas of the hospital were included in data collection for this study. Data was returned from the following hospital ward areas; emergency department,

outpatients unit, oncology and haematology, rehabilitation, surgical, medical, theatre, ICU, burns unit, day stay, mental health, education and management. This representation of all hospital units in the sample is consistent with other research in the paediatric setting (Adwan, 2014; Ernst et al., 2004).

#### *Years in the position*

The majority of paediatric nurses had been employed in their current role for a period of 1-2 years. This is similar to other studies conducted in paediatric nursing (Ernst et al., 2004). Differently, in a study conducted in the paediatric setting in Turkey the average number of years for paediatric nurses was  $4.77 \pm 4.70$  years (Akman et al., 2016). The slightly higher number of years in position in comparison to this present study may be due to cultural and contextual differences between the hospitals and countries.

The majority of middle managers were equally distributed between the 3-4 years and 11 years and over category consisting of seven (30.4%) participants in each. The mean average length of employment for a middle manager was found to be three years or less in a study conducted in the NHS (Osborne, 2014). In contrast, paediatric nurses who worked in the hospital for 10 years or more or more felt they would be more satisfied and productive in a different profession (Kaitelidou et al., 2012). However, this may be different for the middle manager population for which no additional information was found.

## **IMPLICATIONS FOR USE OF THE STUDY FINDINGS**

The study findings presented provides the first on this topic relevant to the Australian and paediatric context. Therefore, these findings have implications for nursing education, nursing leadership and future nursing research.

### **Nursing education**

The significance of communication climate, media quality and supervisor relationships, as a direct and indirect determinants of job satisfaction and intention to look for another job, highlights the need for formal education in personal and professional communication, specifically with an understanding of the differences between a large and small healthcare organisation.

A structured, evidence-based, professional unit on the complexity of healthcare organisational structures is recommended for undergraduate students. An understanding of the way communication is distributed within a healthcare organisation and how it develops cultures and, indirectly impacts on job satisfaction, will allow student nurses to develop the skills necessary to challenge communication weaknesses once graduated. Whilst communication units are recognised within the tertiary academic sector, these tend to focus on the communication with patients and their families (Hall, 2005).

In addition, intense training for management on the benefits of effective communication and relationships with subordinates, including how to facilitate, receive and provide feedback, is of vital importance. Middle managers need to be able to create an environment that promotes effective communication, as they are in a position to influence policy and standards, highlight areas for improvement, support staff and role model effective communication behaviours (Timmins, 2011). Through dedicating time for staff and being available to listen and provide guidance, keeping staff informed, articulating performance expectations and giving feedback (McMurry & Williams, 2004; Parsons & Stonestreet, 2003), better industrial relations, fewer strikes, improved productivity, more suggestions per employee and a heightened level of innovation will result (Clampitt & Downs, 1993). This in turn will increase job satisfaction and will improve nursing retention (Abualrub & Alghamdi, 2012).

### **Nursing leadership**

In addition to educational development, nursing administration need to promote effective organisational communication. The efficacy of communications systems for upward and downward feedback need strengthening in order to improve supervisor subordinate relationships, communication climate and media quality. This will assist in reducing distortion in information travelling up and down the hierarchy through the many levels of management (Jones, 2004), and will reduce the use of grapevines to attain otherwise unavailable information (Harber & Ashkanasy, 1998). Further, adequate infiltration of relevant information is needed to maintain low levels of frustration and development of grapevines. Likewise, creating environments that promote communication and strengthening nursing input into policy, procedures and problem solving may improve the nursing voice within an organisation and may strengthen the relationship between ward nurses and management (Havens, 2001; Rafferty, Ball, & Aiken, 2001). In addition, greater upper management viability, being



approachable, and fostering relationships is needed to enhance organisational commitment of nurses and strengthening lines of communication within an organisation (Adelman, 2010).

In this study, it was highlighted that middle managers were significantly more dissatisfied in:

1. Information about my progress in my job
2. Extent to which my supervisor listens and pays attention to me
3. Extent to which my supervisor offers guidance for solving job related problems
4. Extent to which the amount of supervision given me is about right
5. Extent to which the people in my organisation have great ability as communicators
6. Extent to which informal communication is accurate and active
7. Extent to which the attitudes toward communication in the organisation are basically healthy.

This observation suggests that levels of information flow within the management cohort itself needs to be improved (Tourish & Hargie, 1996). Likewise, Patrick and Laschinger (2006), identified that empowerment for middle managers was positively related to organisational support. In light of these results, and the high turnover rates of the middle management cohort, additional support and guidance is needed from senior management. The mean average length of employment for a middle manager is 3 years or less (Osborne, 2014). Therefore, professional development opportunities for novice nurse managers to promote achievement of learning goals and support (MacPhee & Suryaprakash, 2012) is necessary. Offering mentorship from knowledgeable managers would emphasise the support offered within an organisation (Sullivan, Bretschneider, & McCausland, 2003). Likewise, improving novice nurse manager knowledge of an organisation at a global level would allow for understanding of the processes and structure of the organisation, as well as an understating of goals and key decision makers (Mathena, 2002).

### **Future research**

This present study focused on organisational communication satisfaction in a paediatric setting and the effect this has on job satisfaction and intention to stay. The final model illustrated that supervisor relationships, media quality and communication

climate impacted on job satisfaction and intention to look for another job, and intention to leave one's job. Future research would benefit from further testing and refining the theoretical model for greater understanding of organisational communication satisfaction within the healthcare environment, as this is the first-time organisational communication satisfaction has been investigated in the Australian and paediatric setting.

It is believed by many researchers that by collecting data at one point in time prevents causality of variables. Therefore, the final model of this present study would be best used in a longitudinal design to investigate organisational communication satisfaction over two points in time. This would allow for the effect of time on each determinant of organisational communication satisfaction to help establish the relationship on the final model.

This study could also be strengthened by increasing the number of participants. Although the sample size was in keeping with the size needed according to variable parcelling, a greater number of participants would increase the credibility of the final model. The difficulty of this should be acknowledged as the expected response rate for questionnaire completion in nursing is between 42% and 53% (Aiken et al., 2002).

The present study reveals the limited knowledge known around managerial turnover and job satisfaction. More research is needed around the support for management within nursing as well as managerial job satisfaction and turnover intentions within an acute care tertiary hospital.

In addition, the final model could also be examined in different sectors of the health care system, such as adult acute care, long term care or community care. This would facilitate understanding of the effect of different health care sectors on organisational communication satisfaction, to examine if the relationships of the model are robust in different clinical units or sectors. Further research could also examine organisational communication satisfaction between organisations both nationally and internationally to investigate if the relationships of the model are robust in different cultures, managerial styles and organisational structures.

It would be beneficial to gather qualitative data to further support the relationships identified in this study which would allow paediatric nurses and managers the opportunity to express their thoughts on organisational communication and changes that can be implemented in the future. Economic analysis of the impact of organisational

communications across Australian hospitals would also be beneficial to identify changes that need to be made to information technologies and process redesign, at the national level.

Further research is also needed on the impact of educational level, number of years in current position and age of paediatric nurses and the impact this has on their communication satisfaction levels. This will allow for strategies to be implemented that may improve organisational communication satisfaction levels. In addition further research on the complex relationship between communication satisfaction levels and individual attitudes are needed to identify mechanisms that can strengthen these relationships.

## **STUDY LIMITATIONS**

### **Sample bias**

The first limitation refers to the sample selection and possible sample bias. Convenience sampling was used for the distribution of the surveys. This type of sampling is a non-probability method that allows researchers to select available participants in a timely and inexpensive manner (Polit & Beck, 2013). Sampling in this way provides no external, objective method for assessing the typicalness of the participants, which can lead to problems with generalisability of results to larger populations. Another issue with this type of sampling method is the risk of sampling bias (Gravetter & Forzano, 2016). Gravetter and Forzano (2016), explain that sampling bias caused by using Convenience sampling can be overcome by two methods. Method one is to collect a broad cross section of the sample with participants from different ages, gender and different levels of education to name a few. The second method is to provide a clear description of the participants, how the sample was collected, and who the participants are. In order to overcome sample bias and issues with generalisability, the surveys were distributed to all paediatric nurses and middle managers working at the hospital. This included paediatric nurses with different levels of education, ages, years of experience, area of work and different positions. Unfortunately, gender is one area that cannot be equally represented in this sample as nursing is a female dominant profession, with only 10% of nurses working in Australia being male (Australian Bureau of Statistics, 2013). To further overcome sample bias, a thorough description of the participants is provided in Chapter 4.

## **One study site**

Only collecting data from one paediatric tertiary institution in Western Australia could also be a limitation of the study related to generalisability of study findings. Given the comparable similarities to the population of interest and thorough description of the participants, study findings may be inferred to be applicable to the paediatric population (Shadish, Cook, & Campbell, 2002).

## **Low response rate**

A low response rate can also be a limitation which may undermine the external validity of the results. In this study, a response rate of 42.4% was noted. This is in keeping with the expected response rate of nurses completing surveys' both in the paediatric setting (Adwan, 2014; Ernst et al., 2004) and other speciality areas (Aiken et al., 2002). In order to prevent low response rate in this study an information letter was provided that may have motivated respondents to participate. The questionnaire completion time was kept to a minimum to make completion less time consuming. The time that it took to complete the surveys for this study was approximately 15 minutes. Neatness and clarity of the surveys were also maintained to allow for easy understanding. All of the participants were provided with contact details of the researcher to allow for clarification of issues when needed. In addition, an email reminder about the study was sent out in week four to encourage staff completion.

Low response rates can also result in non-response bias (Rogelberg & Stanton, 2007). Non-response bias relates to variations in relevant survey characteristics between respondents and non-respondents. Differences between these two groups could result in possible measurement errors (Lambert & Harrington, 1990). For this study, non-response bias was tested using the classic method. This method assumes that reluctant responses are similar to non-responses. The characteristics of reluctant participants are then used to estimate the impact of non-participation on study outcomes (Curtin et al., 2000; Lin & Schaeffer, 1995; Montaquila et al., 2008; O'Neil, 1979; Smith, 1984; Stinchcombe et al., 1981). The analysis did not show any significant differences in responses made by the 'before' and 'after' respondents on all 35 items confirming that non-response bias was not an issue for the organisational communication satisfaction survey.

## **Common method variance**

Common method bias arises from common method variance, caused by the method used to collect data and not by the constructs themselves. Common method bias may have been introduced through the self-reporting of both predictor and outcomes variables and by the data being obtained from a single source. In order to identify the risk of bias the CFA underwent common method bias testing using Harman's single factor test and the common latent factor process (Ketchen & Berch, 2006). Harman's single factor test involved performing an exploratory factor analysis. The first variable explained 48.6% of the total variance, which suggested that common method bias was likely (Loser, 2015). The common method factor was used as a second measure of bias. The constrained model had better fit indices than those of the unconstrained model, which shows that common method bias is likely (Ketchen & Berch, 2006). As such a same source factor was added to the indicators of all constructs within the model, which was carried through into the SEM analysis (Ketchen & Berch, 2006).

## **Psychometric properties of study instruments**

The job satisfaction and intention to stay surveys have been used extensively in the nursing profession and have established reliability and validity. However, the organisational communication satisfaction survey has not been used extensively in the realm of nursing and in the paediatric or Australian context. Although unreliable and invalid instruments could have been a limitation of the study, the Psychometric testing of the instrument provided evidence that the communication satisfaction survey and constructs had acceptable levels of internal consistency reliability before measurement model analysis. In addition, Confirmatory Factor Analysis of the measurement model ensured construct validity of the communication satisfaction survey, to confirm that retained items were valid measures of the factor structure. An exception of this was corporate perspective, media quality and horizontal communication which had slight decreases in the internal consistency reliability after the deletion of an item. However, all Cronbach alpha coefficients remained above .70 and therefore, were considered to be an acceptable measure of internal consistency reliability (Weiner & Craighead, 2010).

## **GENERALISABILITY OF STUDY FINDINGS**

Overall, sample demographics as well as survey response rate were similar to characteristics of other studies conducted in nursing and specifically the paediatric

setting. The sample demographics of position, gender, highest level of education and inclusion of different ward areas was consistent with other research conducted in the paediatric settings. Age, employment status and years of experience showed slight difference between results in this study and those of other studies found in the paediatric setting, which may have been attributed to by differences in culture and context between Australia and international settings. Given the comparable similarities to the population of interest, study findings may be inferred to be applicable to the paediatric population (Shadish, Cook, & Campbell, 2002).

## **KNOWLEDGE TRANSFER PLANS**

Knowledge transfer is complex and multidimensional concept that requires the exchange, synthesis and application of knowledge to strengthen health care systems and improve patient outcomes. (World Health Organization, 2005). Based on the study conducted by Lavis and colleagues (2003) the knowledge translation framework should be developed through the use of five questions. These include:

What information should be transferred to decision makers?

Who is the target audience?

Who should transfer the knowledge?

Through what process will the knowledge be translated?

And what will be the effect of the knowledge that is transferred?

In healthcare there are four audiences for knowledge transfer: “general public/service recipients (e.g., citizens, patients, and clients), service providers (e.g., nurses and doctors), managerial decision makers (e.g., managers in hospitals, community organisations, and private businesses), and policy decision makers at the federal, state, and local levels” (Lavis et al., 2003, p. 222).

Knowledge transfer aims to inform audiences of the organisational communication determinants that impact on job satisfaction, intention to leave and look for another job, and solutions to improve organisational communication, as proposed by the research. Administrative audiences, including health care organisations, Chief Nursing Officers, Health Boards and managers across states, in collaboration with nursing education audiences, such as the Council of Deans of Nursing and Midwifery, will be targeted to make changes to the organisational communication systems and structures in place, as well as to implement educational opportunities and mentorship

programs for managers. In addition, study results will also be distributed to the Australian Association of Practice Management, which represents and unites practice managers and the profession of practice management throughout the healthcare industry. Study findings will be further conveyed to supportive interest groups, such as the Australian Nursing Federation. Findings will also be communicated to the target population by means of presentations at conferences, accessible publications of findings in scholarly journals as well as in newsletters and websites.

## **CANDIDATE REFLECTION**

The PhD learning journey has been full of personal achievements and, at times hurdles. As a PhD student, I have learnt to plan, manage, lead a successful research project and facilitate productive discussions with the executive director of nursing, nursing management and ward nurses. Throughout the journey, I have had to develop my skills and knowledge, specifically in SEM, an analysis technique I had not used prior. I have been extremely fortunate to have had such wonderful support throughout the learning journey from both of my supervisors, family and friends that has allowed me to develop strategies for successful research completion.

## **SUMMARY**

This study presented new evidence to develop knowledge regarding both Australian and paediatric nurses' satisfaction with organisational communication. The purpose of this study was to test and refine a hypothesised model that investigated the impact of organisational communication satisfaction on paediatric nurses' job satisfaction, intention to leave and look for another job. The hypothesised model was developed after review of related literature. This is the only study to investigate organisational communication satisfaction within a tertiary paediatric hospital in Australia.

The Mann-Whitney U Test compared the communication satisfaction questions means between middle managers and paediatric nurses and highlighted seven areas of dissatisfaction for middle managers. This highlighted the need for improvement in the management cohort and the addition of extra managerial support and empowerment.

Consistent with the hypothesised model, the constructs of supervisor relationships, media quality and communication climate directly predicted the degree of

job satisfaction and indirectly predicted paediatric nurses' intention to leave their job and looking for another job.

Although several study limitations were present, study findings have established implications for nursing education and nursing leadership. Future research recommends additional methods and areas of investigation to improve the credibility of the final model. Longitudinal study designs, as well as examination of organisational communication, and effects on intention to leave and looking for another job in different clinical areas and health care sectors, would improve the knowledge around this area.

In conclusion, job satisfaction and intention to leave and look for another job were determined to be related to a series of interactions with media quality, communication climate and supervisor relationships. The knowledge from this study provides insights into the areas that need attention to promote effective organisational communication, that will improve practice environments and aid nursing retention strategies, with the ultimate goal of promoting optimum outcomes for patients, nurses and healthcare organisations.



---

## REFERENCES

- Abrahamson, E., & Park, C. (1994). Concealment of negative organizational outcomes: AN agency theory perspective. *Academy of Management Journal*, 37(1302-1334).
- Abualrub, R. F., & Alghamdi, M. G. (2012). The impact of leadership styles on nurses' satisfaction and intention to stay among Saudi nurses. *Journal of Nursing Management*, 20(5), 668-678. doi: 10.1111/j.1365-2834.2011.01320.x
- Adelman, K. S. (2010). *Employee voice and upward communication: A phenomenological collective case study of leadership behaviors in performance excellence award winning health organizations*. Capella University.
- Adler, R., & Rodman, G. (1997). *Understanding Human Communication* (6<sup>th</sup> ed.). USA: Harcourt Brace College Publishers.
- Adrian, A. D., & Ticehurst, G. W. (2001). *Communication and commitment: The role of the holistic communication satisfaction*. Paper presented at the Paper presented at the annual meeting of the Academy of Management Washington, DC, USA.
- Adwan, J. Z. (2014). Pediatric nurses' grief experience, burnout and job satisfaction *Journal of Pediatric Nursing*, 29, 329-336.
- Ahmad, N., & Oranye, N. O. (2010). Empowerment, job satisfaction and organizational commitment: A comparative analysis of nurses working in Malaysia and England. *Journal of Nursing Management*, 18, 582-591. doi: 10.1111/j.1365-2834.2010.01093.x
- Aiken, L. H. (2002). Superior outcomes for magnet hospitals: The evidence base. *Magnet hospitals revisited: Attraction and retention of professional nurses*, 61-81.
- Aiken, L. H., Clarke, S. P., & Sloane, D. M. (2002). Hospital staffing, organization, and quality of care: Cross-national findings. *International Journal for Quality in Health Care*, 14(1), 5-14.
- Akman, O., Ozturk, C., Bektas, M., Ayar, D., & Armstrong, M. A. (2016). Job satisfaction and burnout among paediatric nurses *Journal of Nursing Management*, 24, 923-933.
- Al-Ma'aitah, R., Cameron, S., Armstrong-Stassen, M., & Horsburg, M. (1996). The effect of unit and gender of Jordanian nurses job satisfaction: A comparison of operating room, medical-surgical, and critical care nurses *Seminar in Preoperative Nursing*, 5, 222-229.
- Alexander, J. A., Lichtenstein, R., Oh, H. J., & Ullman, E. (1998). A casual model of voluntary turnover among nursing personnel in long-term psychiatric settings. *Research in Nursing & Health*, 21(5), 415-427.
- Allison, P. D. (2003). Missing data techniques for structural equation modeling. *Journal of Abnormal Psychology*, 112(4), 545.

- Altuntas, S., Altun, O. S., & Akyil, R. C. (2014). The nurses' form of organisational communication: What is the role of gossip. *Contemporary Nurse*, 48(1), 109-116.
- American Association of Colleges of Nursing. (2014). Nursing shortages America. American Association of Colleges of Nursing.
- Amos, M., Hu, J., & Henrick, C. (2005). The impact of team building on communication and job satisfaction of nursing staff. *Journal of Nurses in Staff Development*, 21(1), 10-16.
- Aromataris, E., & Pearson, A. (2014). The systematic review: An overview; Synthesizing research evidence to inform nursing practice. *American Journal of Nursing*, 114, 53-58.
- Ashforth, B., & Gibbs, B. (1990). The double-edge of organizational legitimation. *Organizational Science*, 1, 177-194.
- Atak, M. (2005). The place and importance of unofficial communication within organisations. *Journal of Aviation and Space Technologies*, 2(2), 59-67.
- Australian Bureau of Statistics. (2013). 4102.0 - Australian social trends: Doctors and nurses. Canberra, Australia: Australian Bureau of Statistics.
- Australian Government. (2013). Nursing and midwifery workforce 2012. Australia: Australian Institute of Health and Welfare.
- Australian Government. (2016). How many nurses and midwives are there? Australia: Australian Institute of Health and Welfare.
- Averis, A., & Pearson, A. (2003). Filling the gaps: Identifying nursing research priorities through the analysis of completed systematic reviews. *Joanna Briggs Institute Reports*, 1, 49-126.
- Awad, S. S., Fagan, S. P., Bellows, C., Albo, D., Green-Rashad, B., De La Gaza, M., & Berger, D. H. (2005). Bridging the communication gap in the operating room with medical team training. *The American Journal of Surgery*, 190, 770-774.
- Baker, K. A. (2002). Organizational Communication.
- Bandalos, D. (2002). The effects of item parceling on goodness-of-fit and parameter estimate bias in structural equation modeling. *Structural Equation Modelling*, 9(1), 78-102.
- Bartels, J., Peters, O., de Jong, M., Pruyn, A., & van der Molen, M. (2010). Horizontal and vertical communication as determinants of professional and organisational identification. *Personnel Review*, 39(2), 210-226. doi: 10.1108/00483481011017426
- Batch, M. (2012). *Communication and the casualisation of nursing: A critical ethnography*. (Doctor of Philosophy), Queensland University of Technology.
- Becker, T. E. (1992). Foci and bases of commitment: Are the distortions worth making? *Academy of Management Journal*, 35, 232-244.
- Black, K. (2012). *Business statistics for contemporary decision making* (7th ed.). United States of America: John Wiley & Sons, Ltd.

- Blunch, N. J. (2013). *Introduction to structural equation modeling: Using IBM SPSS statistics and AMOS*. London, UK: Sage Publications.
- Boltyenkov, A. (2015). *A healthcare economic policy for hearing impairment*. Germany: Springer Gabler.
- Boundless. (2014). Feedback, concurrent control, and feed forwards. Boundless Management Retrieved from <https://www.boundless.com/management/textbooks/boundless-management-textbook/control-8/bureaucratic-and-quality-control-tools-and-techniques-63/bureaucratic-control-an-overview-317-7576/>
- Braff, S., Manias, E., Finch, S., Riley, R., & Munro, F. (2012). Healthcare service provider perceptions of organisational communication across the perioperative pathway: A questionnaire survey. *Journal of Clinical Nursing*, 22, 180-191. doi: DOI: 10.1111/j.1365-2702.2012.04228.x
- Brain, S. (2010). Using the library: *Bailliere's study skills for nurses and midwives* (4th ed.). Edinburgh: Balliere Tindall.
- Brooks, I. (2002). Nurse retention: Moderating the ill-effects of shiftwork. *Human Resource Management Journal*, 10(4), 16-30.
- Brunetto, Y., Farr-Wharton, R., & Shacklock, K. (2011). Supervisor–subordinate communication relationships, role ambiguity, autonomy and affective commitment for nurses. *Contemporary Nurse*, 39(2), 227-239.
- Bryne, Z. S., & LeMay, E. (2006). Different media for organizational communication: Perceptions of quality and satisfaction. *Journal of Business and Psychology*, 21(2). doi: 10.1007/s10869-006-9023-8
- Buchan, J., & Aiken, L. H. (2008). Solving nursing shortages: A common priority. *Journal of Clinical Nursing*, 17(24), 3262-3268. doi: 10.1111/j.1365-2702.2008.02636.x
- Burton, R. M., DeSanctis, G., & Obel, B. (2006). *Organizational design: A step by step approach*. New York, USA: Cambridge University Press.
- Byrne, B. M. (2016). *Structural equation modeling with AMOS, basic concepts, applications, and programming* (3rd ed.). New York: Routledge.
- Cai, C. F., Zhou, Z. K., Yeh, H., & Hu, J. (2011). Empowerment and its effects on clinical nurses in central China. *International Nursing Review*, 58(1), 138-144. doi: 10.1111/j.1466-7657.2010.00848.x
- Cavanagh, S. J., & Coffin, D. A. (1992). Staff turnover among hospital nurses. *Journal of Advanced Nursing*, 17(11), 1369-1376.
- Chang, C. S., & Chang, H. C. (2009). Perceptions of internal marketing and organizational commitment by nurses. *Journal of Advanced Nursing*, 65(1), 92-100.
- Chant, S., Jenkinson, T., Randle, J., & Russell, G. (2002). Communication skills: Some problems in nursing education and practice. *Journal of Clinical Nursing*, 11, 12-21.

- Chin, W. W. (1998). Issues and opinion on structural equation modeling *MIS Quarterly*, 22(1), 7-16.
- Christenson, S. L., Reschly, A. L., & Wylie, C. (2012). *Handbook of research on student engagement*. New York: Springer.
- Chu, C., Hsu, H., Price, L., & Lee, J. (2003). Job satisfaction of hospital nurses: An empirical test of a casual model in Taiwan. International Council of Nurses. *International Nursing Review*, 50, 176-182.
- Clampitt, P., & Downs, C. (1993). Employee perceptions of the relationships between communication and productivity: A field study. *Journal of Business Communication*, 30(1), 5-28.
- Coakes, S. J., & Steed, L. (2011). *SPSS: Analysis without anguish using SPSS version 18.0 for Windows*: John Wiley & Sons, Inc.
- Coiera, E., & Tombs, V. (1998). Communication behaviors in a hospital setting: An observational study. *British Medical Journal*, 316.
- Coomber, B., & Barriball, K. L. (2007). Impact of job satisfaction components on intent to leave and turnover for hospital-based nurses: A review of the research literature. *International Journal of Nursing Studies*, 44, 297-314.
- Cosh, A., Fu, X., & Hughes, A. (2012). Organisation structure and innovation performance in different environments *Small Business Economics*, 39(2), 301-317.
- Cowden, T., Cummings, G., & Profetto-McGrath, J. (2011). Leadership practice and staff nurses' intention to stay: A systematic review *Journal of Nursing Management*, 19, 461-477. doi: 10.1111/j.1365-2834.2011.01209.x
- Cummings, G., & Estabrooks, C. A. (2003). The effects of hospital restructuring including layoffs on nurses who remained employed: A systematic review of impact. *International Journal of Sociology and Social Policy*, 23(8-9), 8-53.
- Curtin, R., Presser, S., & Singer, E. (2000). The effects of response rate changes on the index of consumer sentiment. *Public Opinion Quarterly*, 64, 413-428.
- Davidson, H., Folcarelli, P., Crawford, S., Duprat, L., & Clifford, J. (1997). The effects of health reforms on job satisfaction and voluntary turnover among hospital based nurses. *Medical Care*, 35(6), 634-645.
- Diamond, T. (2011). *Middle management in academic and public libraries*. United States of America: Libraries Unlimited.
- Downs, A. (1991). *The relationship between communication and organizational communication in two Australian organizations*. University of Kansas. Lawrence, K.S.
- Downs, C., & Adrian, A. D. (2004). *Assessing organisational communication: Strategic communication audit*. New York: The Guilford Press.
- Downs, C. W. (1994). Communication satisfaction questionnaire. *Communication research measures: A sourcebook*. New York: Guilford.

- Downs, C. W., & Hazen, M. D. (1977). A factor analytic study of communication satisfaction. *Journal of Business Communication*, 14(3), 63-73.
- Duffield, C., Kearin, M., Johnston, J., & Leonard, J. (2007). The impact of hospital structure and restructuring on the nursing workforce. *Australian Journal of Advanced Nursing*, 24(4), 42-46.
- Duffield, C., Roche, M. A., Blay, N., Thoms, D., & Stasa, H. (2011). The consequences of executive turnover in Australian hospitals. *Journal of Research in Nursing*, 16(6), 503-514.
- Duffield, C. M., & O'Brien-Pallas, L. (2003). The causes and consequences of nursing shortages: A helicopter view of the research. *Australian Health Review*, 26(1), 186-193.
- Edwards, N., Peterson, W. E., & Davies, B. L. (2006). Evaluation of a multiple component intervention to support the implementation of a 'Therapeutic Relationships' best practice guideline on nurses' communication skills. *Patient Education and Counseling*, 63(1), 3-11.
- Eisenberg, E. M., & Witten, M. G. (1987). Reconsidering openness in organisational communication. *Academy of Management Review*, 12, 418-426.
- Ender, C. K., & Bandalos, D. (2001). The relative performance of full information maximum likelihood estimation of missing data in structural equation models. *Educational Psychology Papers and Publications*, Paper 64.
- Erenstein, C. F., & McCaffrey, R. (2007). How healthcare environments influence nurse retention. *Journal of Holistic Nursing Practice*, November/December 303-307.
- Ernst, M. E., Franco, M., Messmer, P. R., & Gonzalez, J. L. (2004). Nurses' job satisfaction, stress and recognition in a paediatric setting. *Paediatric Nursing*, 30(3), 219-227.
- Estabrooks, C. A., Floyd, J. A., Scott-Findlay, S., O'Leary, K. A., & Gushta, M. (2003). Individual determinants of research utilization: a systematic review. *Journal of Advanced Nursing*, 43(5), 506-520.
- Falcione, R. L., Sussman, L., & Herden, R. P. (1987). Communication climate in organizations. *Handbook of organizational communication: An interdisciplinary perspective*. Newbery Park, California: Sage.
- Feather, R. A., Ebright, P., & Bakas, T. (2015). *Nurse manager behaviors that RNs perceive to affect their job satisfaction*. Paper presented at the Nursing Forum.
- Finch, J. F., & West, S. G. (1997). The investigation of personality structure: Statistical models. *Journal of Research in Personality*, 31, 439-485.
- Fink, A. (2010). *Conducting research literature reviews: From the internet to paper* (3rd ed.). USA: SAGE Publications. Inc.
- Frone, M. R., & Major, B. (1988). Communicating quality and job satisfaction among managerial nurses: the moderating influence of job involvement. *Group & Organizational Studies*, 13(3), 332-347.

- Garon, M. (2012). Speaking up, being heard: Registered nurses' perceptions of workplace communication. *Journal of Nursing Management*, 20(3), 361-371.
- Gerster, C. R., & Day, D. V. (1997). Meta-analytic review of leader-member exchange theory; correlates and construct issues. *Journal of Applied Psychology*, 82(6), 827-844.
- Gibson, J. L., Ivancevich, J. M., Donnelly, J. H., Jr., & Konopaske, R. (2009). *Organizations. Behavior, structure, and processes* (13<sup>th</sup> ed.). New York, USA: McGraw-Hill/Irwin.
- Government of Western Australia. (n.d). Child and adolescent health services. Retrieved January 3rd 2014, from [http://www.pmh.health.wa.gov.au/general/about\\_us/](http://www.pmh.health.wa.gov.au/general/about_us/)
- Gravetter, F. J., & Forzano, L. B. (2016). *Research methods for the behavioural sciences* (5th ed.). USA: Cengage Learning.
- Gray, J., & Laidlaw, H. (2004). Improving the measurement of communication satisfaction. *Management Communication Quarterly: McQ*, 17(3), 425-448.
- Gregson, T. (1987). An empirical investigation of the relationships between communication satisfaction, job satisfaction, turnover, and performance for public accountants. *Dissertation Abstracts International*, 48(1254A).
- Griffeth, R. W., Hom, P. W., & Gaertner, S. (2000). A meta-analysis of antecedents and correlates of employee turnover: Update, moderator tests, and research implications for the next millennium. *Journal of Management*, 26(3), 463-488.
- Gurková, E., Soósová, M., Haroková, S., Žiaková, K., Šerfelová, R., & Zamboriová, M. (2013). Job satisfaction and leaving intentions of Slovak and Czech nurses. *International Nursing Review*, 60(1), 112-121.
- Hair, J., Black, W., Babin, B., & Anderson, R. (2010). *Multivariate data analysis* (7th ed ed.). Upper Saddle River, NJ, USA: Prentice-Hall, Inc.
- Hall, P. (2005). Interprofessional teamwork: Professional cultures as barriers. *Journal of Interprofessional Care, Supp 1*, 188-196.
- Harber, D. G., & Ashkanasy, N. M. (1998). Culture, communication and service quality in health care administration: A tale of two hospitals. *Australian Health Review*, 21(3).
- Hartung, S. Q., & Miller, M. (2013). Communication and the healthy work environment: Nurse managers' perceptions. *Journal of Nursing Administration*, 43(5), 266-273.
- Harvey, M., & Land, L. (2016). *Research Methods for Nurses and Midwives: Theory and Practice*. London, UK, SAGE Publications Limited.
- Havens, D. S. (2001). Comparing nursing infrastructure and outcomes: ANCC magnet and non-magnet CNE's report: chief nurse executives. *Nurse Economics*, 19(6), 258-266.
- Hayes, A. F. (Producer). (2012). PROCESS: A versatile computational tool for observed variable mediation, moderation, and conditional process modeling. [White paper] Retrieved from <http://www.afhayes.com/public/process2012.pdf>

- Hazell, K. W. (2010). *Job stress, burnout, job satisfaction, and intention to leave among registered nurses employed in hospital settings in the state of Florida*. Lynn University.
- Health Workforce Australia. (2014). *Health workforce Australia 2014: Australia's future health workforce: Nurses overview report*. Canberra: Department of Health.
- Heath, J., Johanson, W., & Blake, N. (2004). Healthy work environments: A validation of the literature *Journal of Nursing Administration, 34*(524-530).
- Hegney, D., Eley, R., Plank, A., Buikstra, E., & Parker, V. (2006). Workplace violence in Queensland, Australia: The results of a comparative study. *International Journal of Nursing Practice, 12*(4), 220-231.
- Hegney, D., McCarthy, A., Rogers-Clark, C., & Gorman, D. (2002). Why nurses are attracted to rural and remote practice? *Australian Journal of Rural Health, 10*(3), 178-186.
- Hegney, D., Plank, A., & Parker, V. (2006). Extrinsic and intrinsic work values: Their impact on job satisfaction in nursing. *Journal of Nursing Management, 14*(4), 271-281.
- Hickey, N., Sumsion, J., & Harrison, L. (2010). Nursing double degrees: A higher education initiative in times of nursing shortages. *Australian Journal of Advanced Nursing, 28*(1), 52-59.
- Horsley, K. (1996). Communication? The vital link in best practice organizations. *Australian Health Review, 19*(4).
- Houmanfar, R., & Johnson, R. B. (2004). Organizational implications of gossip and rumor. *Journal of Organizational Behavior Management, 23*(2-3), 117-138.
- Hunt, S. R., Corazzini, K., & Anderson, R. A. (2014). Top nurse-management staffing collapse and care quality in nursing homes. *Journal of Applied Gerontology, 33*(1), 51-74.
- Hutton, D. W. (1994). *The change agents handbook: A survival guide for quality improvement champions*. Milwaukee: ASQC Quality Press.
- International Council of Nurses. (2006). *ICN. The global nursing shortage: Priority areas for intervention*. Geneva: International Council of Nurses.
- Janney, M. A., Horstman, P. I., & Bane, D. (2001). Promoting registered nurse retention through shared decision making. *Journal of Nursing Administration, 31*(10), 483-488.
- Jasper, M. (2007). Editorial. The significance of the working environment to nurses' job satisfaction and retention. *Journal of Nursing Management, 15*(3), 245-247.
- Joanna Briggs Institute. (2010). *Critical appraisal tools for use in JBI systematic reviews*. Australia, Joanna Briggs Institute. Retrieved from: <https://joannabriggs.org/research/critical-appraisal-tools.html>
- Jones, G. R. (2004). *Organizational theory, design, and change: Text and cases* (4th ed.). New Jersey, USA: Person Prentice Hall.

- Kaddourah, B. T., Khalidi, A., Abu-Shaheen, A. K., & Al-Tannir, M. A. (2013). Factors impacting job satisfaction among nurses from a tertiary care centre. *Journal of Clinical Nursing*, 22, 3153-3159.
- Kaitelidou, D., Kontogianni, A., Galanis, P., Siskou, O., Mallidou, A., Pavlakis, A., . . . Liaropoulos, L. (2012). Conflict management and job satisfaction in paediatric hospitals in Greece. *Journal of Nursing Management*, 20, 571-578.
- Kandlousi, N. S. A. E., Ali, J. A., & Abdollahi, A. (2010). Organizational citizenship behavior in concern of communication satisfaction: The role of the formal and informal communication. *International Journal of Business and Management*, 5(10), 51-61.
- Ketchen, D. J., & Berch, D. D. (Eds.). (2006). *Research methodology in strategy and management* (Vol. 3). UK: Elsevier.
- Keyton, J. (2005). *Communication and organizational culture*. California, USA: Sage Publications, Inc.
- Khodadadi, E., Ebrahimi, H., Moghaddasian, S., & Babapour, J. (2013). The effect of communication skills training on quality of care, self-efficacy, job satisfaction and communication skills rate of nurses in hospitals of Tabriz, Iran. *Journal of Caring Sciences*, 2(1), 27.
- Kio, B. A. (1980). A descriptive study of communication satisfaction, need satisfaction and need importance among Nigerian workers. *Dissertation Abstracts International*, 41(19A).
- Kline, R. B. (2005). *Principles of structural equation modeling* (2nd ed.). New York: Guilford Press.
- Kline, R. B. (2011). *Principles and practice of structural equation modeling* (3rd ed.). USA: Guilford Publishers.
- Kreps, G. L. (1990). *Organisational communication* (2<sup>nd</sup> ed.). New York, USA: Longman.
- Kubica, A. J. (2008). Transitioning middle managers. *Healthcare Executive*, 23(2), 58-60.
- Kushal, S. J., & Ahuja, S. (2009). *Business Communication*. New Delhi: V.K (India) Enterprises.
- Lambert, D. M., & Harrington, T. C. (1990). Measuring nonresponse bias in customer service mail surveys. *Journal of Business Logistics*, 11(2), 5-25.
- Laschinger, H., & Finegan, J. (2005). Using empowerment to build trust and respect in the workplace: A strategy for addressing the nursing shortage. *Nurse Economics*, 23(1), 6-13.
- Lavis, J. N., Robertson, D., Woodside, J. M., McLead, C. B., Abelson, J., & Knowledge Transfer Study Group. (2003). How can research organization more effectively transfer research knowledge to decision makers? *The Milbank Quarterly*, 81 (2), 221-248.



- Le Roy, M. K. (2013). *Research methods in political science: An introduction using MicroCase*.
- Lei, P.-W., & Wu, Q. (2007). Introduction to structural equation modelling: Issues and practical considerations. *Educational Management: Issues and Practice*, 26(3), 33-43.
- Lin, I.-F., & Schaeffer, N. C. (1995). Using survey participants to estimate the impact of nonparticipation *Public Opinion Quarterly*, 2, 236-258.
- Lincoln, Y. S., & Guba, E. G. (1985). *Naturalistic Inquiry*. Beverly Hills, USA: Sage Publications, Inc.
- Lindlof, T., & Taylor, B. (2002). *Qualitative communication research methods*. United States of America: Sage Publications, Inc.
- Lluch, M. (2011). Healthcare professionals' organisational barriers to health information technologies: A literature review. *International Journal of Medical Informatics*, 80, 849-862.
- Loser, F. (2015). *Strategic information systems management for environmental sustainability: Enhancing firm competitiveness with Green IS*: Universitätsverlag der TU Berlin.
- Lu, H., While, A. E., & Barriball, K. L. (2007). Job satisfaction and its related factors: A questionnaire survey of hospital nurses in mainland China. *International Journal of Nursing Studies*, 44, 574-588.
- Luthans, F. (2011). *Organizational behavior: An evidence-based approach* (12<sup>th</sup> ed.). New York, USA: McGraw-Hill/Irwin.
- Ma, C.-C., Samuels, M. E., & Alexander, J. W. (2003). Factors that influence nurses' job satisfaction. *Journal of Nursing Administration*, 33(5), 293-299.
- Ma, J.-C., Lee, P.-H., Yang, Y.-C., & Chang, W.-Y. (2009). Predicting factors related to nurses' intention to leave, job satisfaction, and perception of quality of care in acute care hospitals. *Nursing Economics*, 27(3), 178.
- Macnee, C. (2004). *Understanding nursing research: Reading and using research in practice*. USA: Lippincott Williams & Wilkins.
- MacPhee, M., & Suryaprakash, N. (2012). First-line nurse leaders' health-care change management initiatives. *Journal of Nursing Management*, 20, 249-259.
- Martin, J. (2005). *Organizational behavior and management* (3<sup>rd</sup> ed.). London, UK: Thomson Learning.
- Marx, M. (2014). Examining the structural challenges to communication as experienced by nurse managers in two US hospital settings. *Journal of Nursing Management*, 22(8), 964-973.
- Mason, C. H., & Perreault, J. W. D. (1991). Collinearity, power, and interpretation of multiple regression analysis. *Journal of Marketing Research*, 28(3), 268-280.
- Mathena, K. A. (2002). Nursing manager leadership skills. *Journal of Nursing Administration*, 32(3), 136-142.

- McAlearney, A. S., & Butler, P. W. (2008). Using leadership development programs to improve quality and efficiency in healthcare. *Journal of Healthcare Management, 53*(5), 319-332.
- McCabe, C. (2004). Nurse-patient communication: An exploration of patients' experiences. *Journal of Clinical Nursing, 13*, 41-49.
- McCaffrey, R., Hayes, R. M., Cassell, A., Miller-Reyes, S., Donaldson, A., & Ferrell, C. (2011). The effect of an educational programme on attitudes of nurses and medical residents towards the benefits of positive communication and collaboration. *Journal of Advanced Nursing, 68*(2), 293-301.
- Mckee, A., Kemp, T., & Spence, G. (2012). *Management: A focus on leaders*. Australia: Pearson.
- McMurry, A. J., & Williams, L. (2004). Factors impacting on nurse managers' ability to be innovative in a decentralized structure. *Journal of Nursing Management, 12*, 348-353.
- Mehmetoglu, M., & Jakobsen, G. (2017). *Applied statistics using STATA: A guide for the social sciences*. London, UK, Sage Publication Limited.
- Mohammad Mosadeghrad, A. (2014). Occupational stress and its consequences: Implications for health policy and management. *Leadership in Health Services, 27*(3), 224-239.
- Montaquila, J. M., Brick, J. M., Hagedorn, M. C., Kennedy, C., & Keeter, S. (2008). Aspects of nonresponse bias in RDD telephone surveys. *Advances in Telephone Methodology*, Hoboken, NJ: Wiley.
- Moore, S. C., & Hutchison, S. A. (2007). Developing leaders at every level. *Journal of Nursing Administration, 37*(12), 564-568.
- Morrison, A. L., Beckmann, U., Durie, M., Carless, R., & Gillies, D. M. (2001). The effects of nursing staff inexperience (NSI) on the occurrence of adverse patient experiences in ICUs. *Australian Critical Care, 14*(3), 116-121.
- Mosadeghrad, A. M., & Ferdosi, M. (2013). Leadership, job satisfaction and organizational commitment in healthcare sector: Proposing and testing a model. *Materia Socio-medica, 25*(2), 121.
- Mrayyan, M. T. (2008). Hospital organizational climates and nurses' intent to stay: differences between units and wards. *Contemporary Nurse: A Journal for the Australian Nursing Profession, 27*(2), 223-236. doi: 10.5172/conu.2008.27.2.223
- Muchinsky, P. M. (1977). Organisational communication: Relationship to organisational climate and job satisfaction. *Academy of Management Journal, 20*(4), 592-607.
- Muller, M. (1995). Participative management in health care services. *Curationis, 18*(1), 15-21.
- Munn, Z., Tufanaru, C., & Aromataris, E. (2014). Data extraction and synthesis: The steps following study selection in a systematic review *The Joanna Briggs Institute, 114*.

- Munro, B. H. (2005). *Statistical methods for health care research* (5th ed.). USA: Lippincott, Williams & Wilkins.
- Muthen, L. K., & Muthen, B. O. (2002). How to use a Monte Carlo study to decide on sample size and to determine power. *Structural Equation Modelling*, 9(4), 599-620.
- National Health and Medical Research Council. (2015). National statement on ethical conducting human research 2007. Commonwealth of Australia.
- Naz, S., & Gul, S. (2014). Moderating role of organizational commitment between communication satisfaction and turnover intentions among nurse. *Pakistan Journal of Psychological Research*, 29(1), 39-52.
- Ndiwane, A. (1999). Factors that influence job satisfaction of nurses in urban and rural community health centers in Cameroon: Implications for policy. *Clinical Excellence of Nursing Practice*, 3(3), 172-180.
- Needleman, J., Buerhaus, P., Mattke, S., Stewart, M., & Zelevinsky, K. (2002). Nurse-staffing levels and the quality of care in hospitals. *The New England Journal of Medicine*, 346(22), 1715-1722.
- Nieswiadomy, R. M. (2012). *Foundations of nursing research* (6<sup>th</sup> ed.). USA: Pearson.
- Nursing and Midwifery Board of Australia. (2006). National competency standards for the registered nurse. Australia Nursing and Midwifery Board of Australia.
- O'Loughlin, K., Humpel, N., & Kendig, H. (2010). Impact of the global financial crisis on employed Australian baby boomers: A national survey: The Phenomenological approach in nursing research. *Nursing Research*, 31(3), 178-181.
- O'Neil, M. J. (1979). Estimating nonresponse bias in RDD telephone surveys. *Advances in Telephone Survey Methodology*, Hoboken, NJ: Wiley.
- O'Toole, G. (2012). *Communication: Core interpersonal skills for health professionals*, (3<sup>rd</sup> ed.). Australia: Elsevier.
- O'Brien-Pallas, L., Thomson, D., Hall, M. L. M., Pink, G., Kerr, M., Wang, S., . . . Meyer, R. (2003). Evidence-based standards for measuring nurse staffing and performance projec t# RC1-0621-06.
- Osborne, K. (2014). Nursing standard research reveals high turnover of top level staff. *Nursing Standard*, 28(49), 7.
- Olden, P. C. (2012). Managing mechanistic and organic structures in health care organizations. *The Health Care Manager*, 31(4), 357-364.
- Ostroff, C., Kinicki, A. J., & Tamkins, M. M. (2003). Organizational culture and climate In Wiley (Ed.), *Handbook of Psychology: volume 12 Industrial and Organizational Psychology*. New York.
- Oxtoby, K. (2003). Men in nursing. *Nursing Times*, 99 (32), 20-23.
- Parsons, M. L., & Stonestreet, J. (2003). Factors that contribute to nurse manager retention, *Nursing Economics*, 21(3), 120-126.

- Patrick, A., & Laschinger, H. K. S. (2006). The effect of structural empowerment and perceived organizational support on middle level nurse managers' role satisfaction. *Journal of Nursing Management*, *14*(1), 13-22. doi: 10.1111/j.1365-2934.2005.00600.x
- Pearson, A. (1985). Nurses as change agents and a strategy for change. *Nursing Practice*, *1*, 80-84.
- Penprase, B., & Norris, D. (2004). *What nurse leaders should know about complex adaptive systems theory*. Paper presented at the Nursing Leadership Forum.
- Pincus, J. D. (1986). Communication satisfaction, job satisfaction and job performance. *Human Communication Research*, *12*(3), 395-419. doi: 10.1111/j.1468-2958.1986.tb00084.x
- Polit, D. F., & Beck, C. T. (2013). *Essentials of nursing research: Appraising evidence for nursing practice* (8th ed.). Pennsylvania, USA: Wolter Kluwer, Lippincott Williams & Wilkins.
- Postmes, T. (2003). A social identify approach to communication in organizations. *Social identity at work developing theory for organizational practice* (pp. 81-98). New York, USA: Psychology Press.
- Postmes, T., Tanis, M., & De Wit, B. (2001). Communication and commitment in organizations: A social identity approach. *Group Processes and Intergroup Relations*, *4*(3), 227-246.
- Potvin, T. C. (1992). Employee organizational commitment: An examination of its relationship to communication satisfaction and an evaluation of questionnaires designed to measure the construct. *Dissertation Abstracts International*, *52*(4147A).
- Price, J. L. (2001). Reflections on the determinants of voluntary turnover. *International Journal of Manpower*, *22*(7), 600-324.
- Price, J. L., & Mueller, C. W. (1981). A causal model of turnover for nurses. *Academy of Management Journal*, *24*(3), 543-565.
- Putnis, P., & Petelin, R. (1999). *Professional communication: Principles and Applications* (2<sup>nd</sup> Ed.). Australia: Prentice-Hall.
- Rafferty, A. M., Ball, J., & Aiken, L. H. (2001). Are teamwork and professional autonomy compatible, and do they result in improved hospital care? *Quality in Health Care*, *10*, 1132-1137.
- Ramoo, V., Abdullah, K. L., & Piaw, C. Y. (2013). The relationship between job satisfaction and intention to leave current employment among registered nurses in a teaching hospital. *Journal of Clinical Nursing*, *22*(21-22), 3141-3152.
- Ritu Agarwal, M., Sands, D. Z., & Jorge Díaz Schneider BS, M. (2010). Quantifying the economic impact of communication inefficiencies in US hospitals. *Journal of Healthcare Management*, *55*(4), 265.
- Robertson-Malt, S., & Chapman, Y. (2008). Finding the right direction: The importance of open communication in governance model of nurse management, *Contemporary Nurse*, *29*(1).

- Rogelberg, S. G., & Stanton, J. M. (2007). Understanding and dealing with organizational survey nonresponse. *Organizational Research Methods, 19*(2), 195-209.
- Rouse, R. A., & Al-Maqbali, M. (2014). Identifying nurse managers' essential communication skills: An analysis of nurses' perceptions in Oman. *Journal of Nursing Management, 22*(2), 192-200.
- Schneider, A. E., Donaghy, W. C., & Newman, P. J. (1975). *Organizational Communication*. USA: McGraw-Hill Inc.
- Shadish, W. R., Cook, T. D., & Campbell, D. T. (2002). *Experimental and quasi-experimental designs for generalized causal inference*. Belmont, CA: Wadsworth Cengage Learning.
- Sias, P. M. (2005). Workplace relationship quality and employee information experiences. *Communication Studies, 56*(4), 375-395.
- Smith, T. W. (1984). Estimating nonresponse bias with temporary refusals *Social Perspectives, 27*, 473-489.
- Spence-Laschinger, H. K., Purdy, N., & Almost, J. (2007). The impact of leader-member exchange quality, empowerment, and core self-evaluation on nurse manager's job satisfaction. *Journal of Nursing Administration, 37*(5), 221-229.
- Sproll, N. L. (2002). *Handbook of research methods: A guide for practitioners and students in the social sciences* (2nd ed.). USA: Scarecrow Press, Inc.
- Stein-Parbury, J. (2008). *Communication for effective nursing: Transitions in nursing preparing for professional practice* (2<sup>nd</sup> ed.). NSW, Australia: Elsevier, Churchill Livingstone.
- Stelzl, I. (1986). Changing a casual hypothesis without changing the fit: Some rules for generating equivalent path models. *Multivariate Behavioural Research, 21*(3), 309-331.
- Stinchcombe, A. L., Jones, C., & Sheatsley, P. (1981). Nonresponse bias for attitude questions. *Public Open Quarterly, 45*, 359-375.
- Strachota, E., Normandin, P., O'Brien, N., Clary, M., & Krukow, B. (2003). Reasons registered nurses leave or change employment status, *Journal of Nursing Administration, 33*(2), 111-117.
- Suddaby, E. C., & Josephson, K. (2013). Satisfaction of nurses with the withdrawal assessment Tool-1 (WAT-1). *Paediatric Nursing, 39*(5), 238-259.
- Sullivan, J., Bretschneider, J., & McCausland, M. (2003). Designing a leadership development program for nurse managers. *Journal of Nursing Administration, 33*(10), 544-549.
- Suresh, N. (2011). Who are the unengaged and what do they mean for our data? *QUIRKS: Marketing Research Media, November 2011, Page 46*.
- Sutcliffe, K., Lewton, E., & Rosenthal, M. (2004). Communication failures: An insidious contributor to medical mishaps. *Academic Medicine, 79*, 186-194.

- Sutton, R., & Callahan, A. (1987). The stigma of bankruptcy: Spoiled organisational image and its management. *Academy of Management Journal*, 30, 405-436.
- Tabachnik, B. G., & Fidell, L. S. (1996). *Using multivariate statistics* (3rd ed.). New York: Harper Collins.
- Timmins, F. (2011). Managers' duty to maintain good workplace communications skills, *Nursing Management*, 18(3).
- Tourangeau, A. E., & Cranley, L. A. (2006). Nurse intention to remain employed: Understanding and strengthening determinants. *Journal of Advanced Nursing*, 55(4), 497-509.
- Tourish, D., & Hargie, O. (1996). Communication in the NHS: Using qualitative approaches to analyse effectiveness. *Journal of Management in Medicine*, 10(5), 38-54.
- Tourish, D., & Mulholland, J. (1997). Communication between nurses and nurse managers: a case study from the NHS Trust. *Journal of Nursing Management*, 5(25-36).
- Tourish, D., & Robson, P. (2004). Critical upward feedback in organisations: Processes, problems and implications for communication management. *Journal of Communication Management*, 8(2), 150-167.
- Uhl-Bien, M., Marion, R., & McKelvey, B. (2007). Complexity leadership theory: Shifting leadership from the industrial age to the knowledge era. *The Leadership Quarterly*, 18(4), 298-318.
- Ulrich, B. T., Woods, D., Hart, K. A., Lavandero, R., Leggett, J., & Taylor, D. (2007). Critical care environments: Value of excellence in Beacon units and Magnet organisations. *Critical Care Nurse*, 27(3), 68-77.
- Upendicks, V. (2002). What constitutes successful nurse leadership? A qualitative approach to utilizing Kanter's Theory of organizational behavior. *Journal of Nursing Administration*, 32(12), 622-632.
- Van Breukelen, W., Van der Vlist, R., & Steensma, H. (2004). Voluntary employee turnover: Combining variables from the 'traditional' turnover literature with the theory of planned behavior. *Journal of Organizational Behavior*, 25(7), 893-914.
- Van Den Tooren, M., & De Jonge, J. (2008). Managing job stress in nursing: What kind of resources do we need? *Journal of Advanced Nursing*, 63(1), 75-84.
- Varona, F. (1996). Relationship between communication satisfaction and organizational commitment in three Guatemalan organizations. *Journal of Business Communication*, 33(2), 111-131.
- Veld, M., Paauwe, J., & Boselie, P. (2010). HRM and strategic climates in hospitals: does the message come across at the ward level? *Human Resource Management Journal*, 20(4), 339-356.
- Wang, L., Tao, H., Ellenbecker, C. H., & Liu, X. (2012). Job satisfaction, occupational commitment and intent to stay among Chinese nurses: A cross-sectional questionnaire survey. *Journal of Advanced Nursing*, 68(3), 539-549.

- Warr, P., Cook, J., & Wall, T. (1979). Scales for the measurement of some work attitudes and aspects of psychological well-being. *Journal of Occupational Psychology*, 52, 129-148.
- Watson, R., Mckenna, H., Cowman, S., & Keady, J. (2008). *Nursing research: Designs and methods*. London, UK: Elsevier Health Sciences.
- Weiner, I. B., & Craighead, W. E. (2010). *The Corsini encyclopedia of psychology. Volume 4, R-Z Brief biographies index* (4th ed. Vol. 4). New Jersey, USA: John Wiley & Sons, Inc.
- Welch, S.-A. (2006). Understanding clinical-culture: Organizational communication in the clinical practicum. *The Internet Journal of Allied Health Sciences and Practice*, 4(4).
- Weston, R., Gore, P., Chan, F., & Catalano, D. (2008). An introduction to using structural equation models in rehabilitation psychology. *Rehabilitation Psychology*, 53(3), 340-356.
- Williams, R., Silverman, R., Schwind, C., Fortune, J., Sutyak, J., Horvath, K., . . . Dunnington, G. (2007). Surgeon information transfer and communication: Factors affecting quality and efficiency of inpatient care. *Annals of Surgery*, 245, 159-169.
- Wilson, D. O. (1992). Diagonal communication links within an organizations. *The Journal of Business Communication*, 29(129-141).
- World Health Organization. (2005). Bridging the "Know-Do" gap: Meeting on knowledge translation in global health.
- Wright, K. B. (2011). A communication competence approach to healthcare worker conflict, job stress, job burnout, and job satisfaction. *Journal for Healthcare Quality*, 33(2), 7-14.
- Yazici, H. J. (2002). The role of communication in organizational change: An empirical investigation. *Information and Management*, 39, 539-552.

---

# APPENDIX A: HISTOGRAMS SHOWING DISTRIBUTION AND NORMALITY

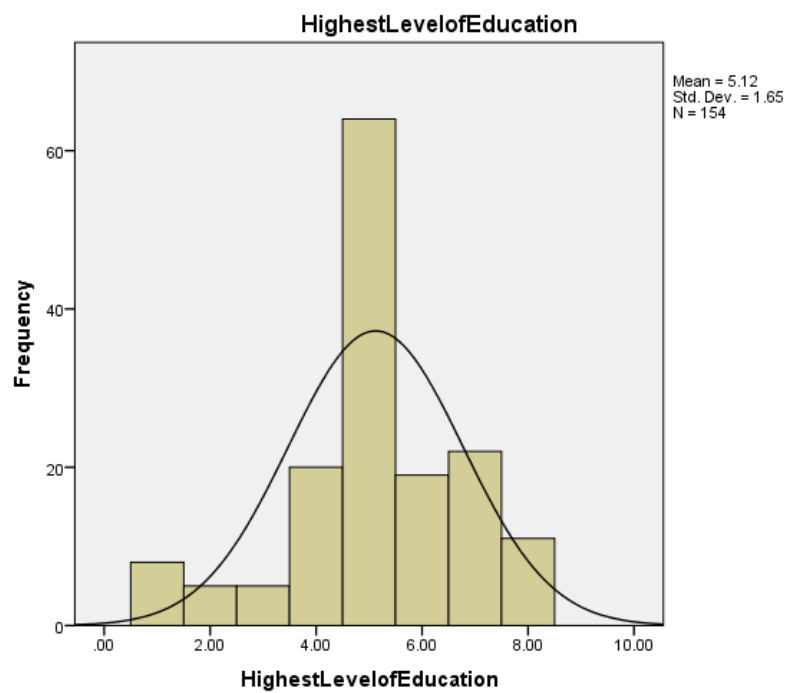
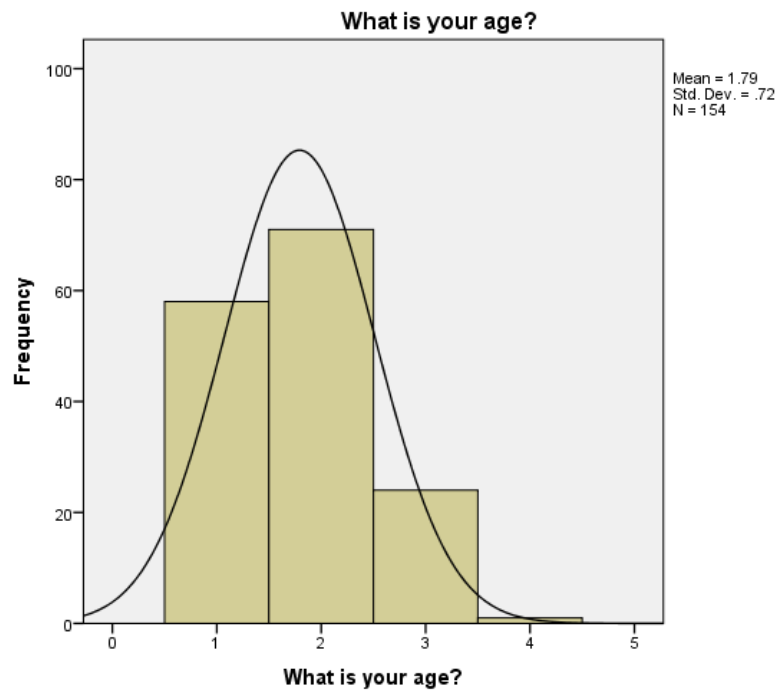



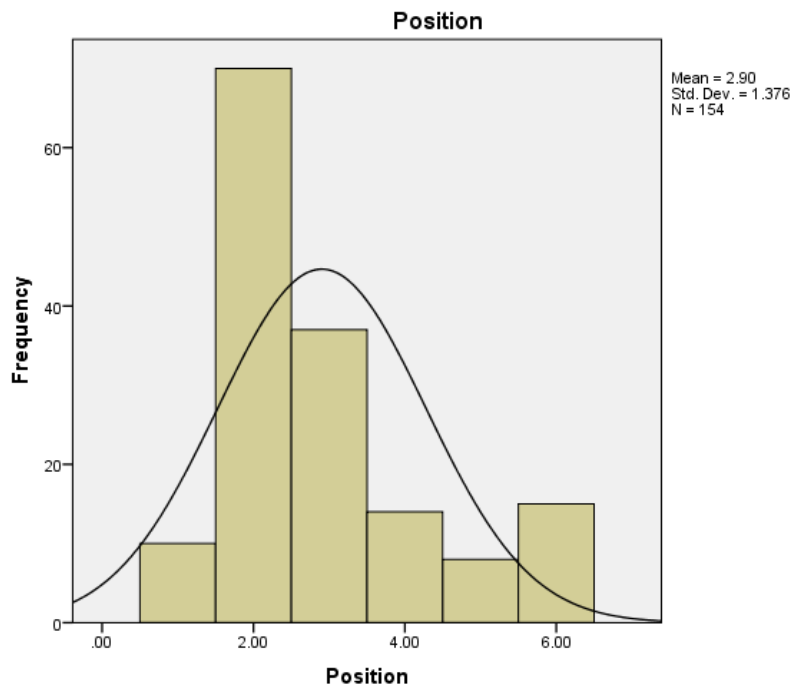
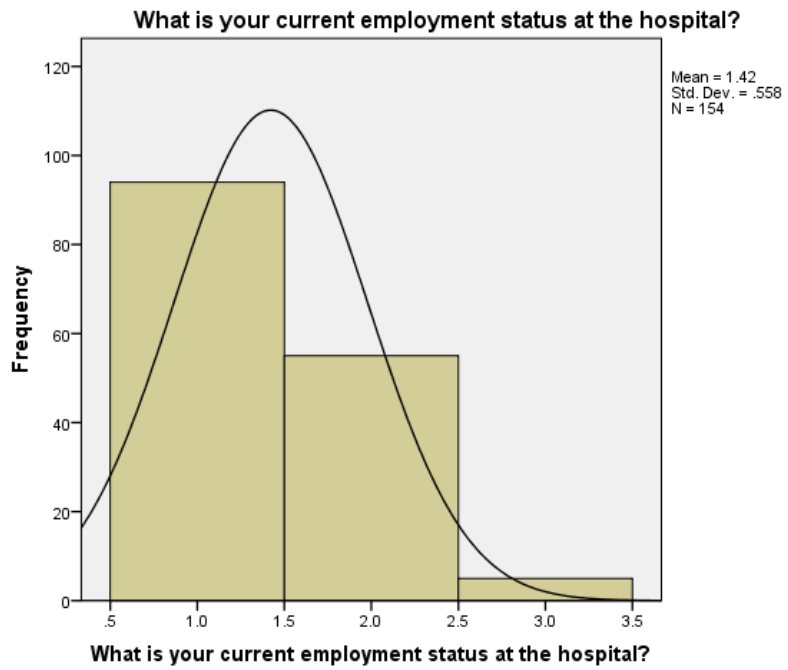

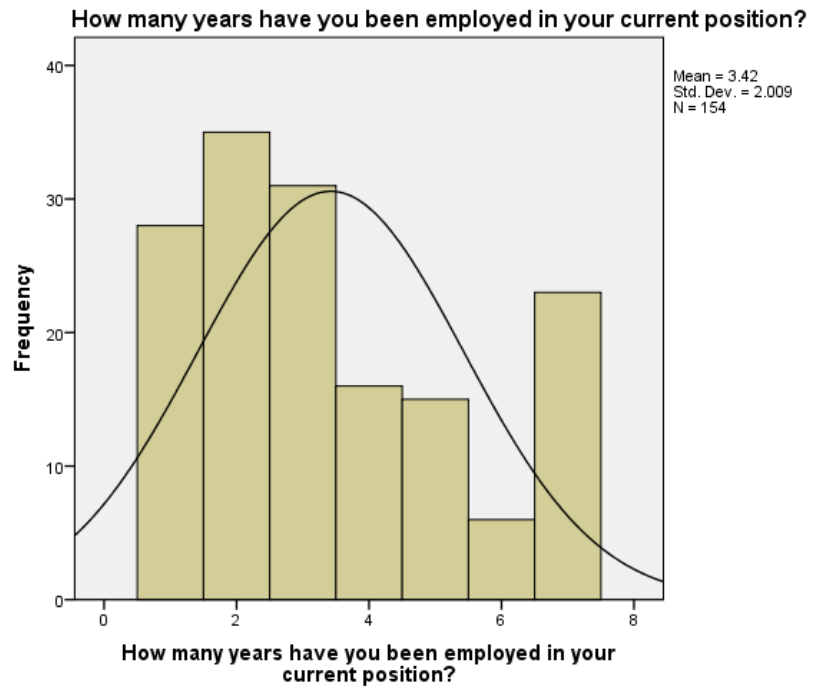
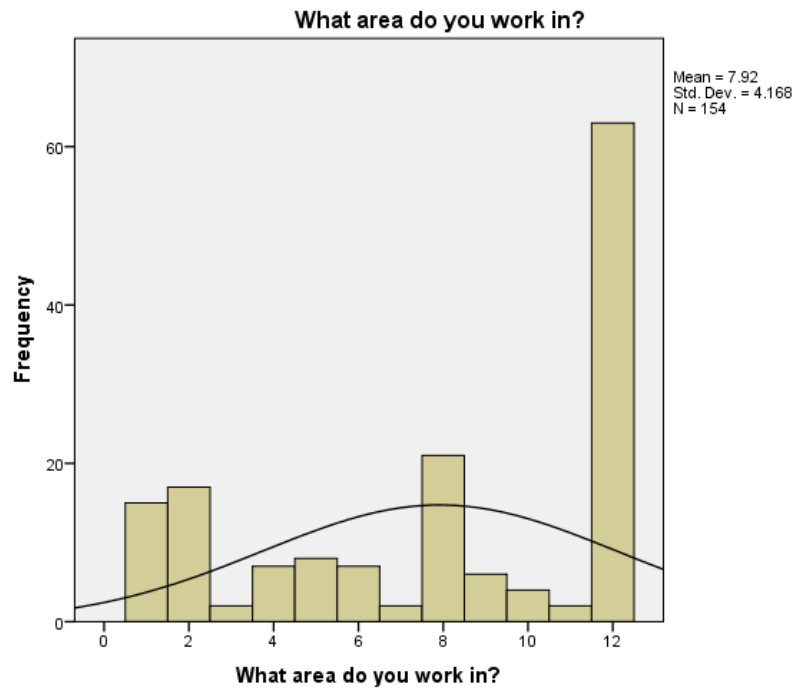

Listed below are several kinds of information often associated with a person's job. please indica...-Information about my progress in my job1

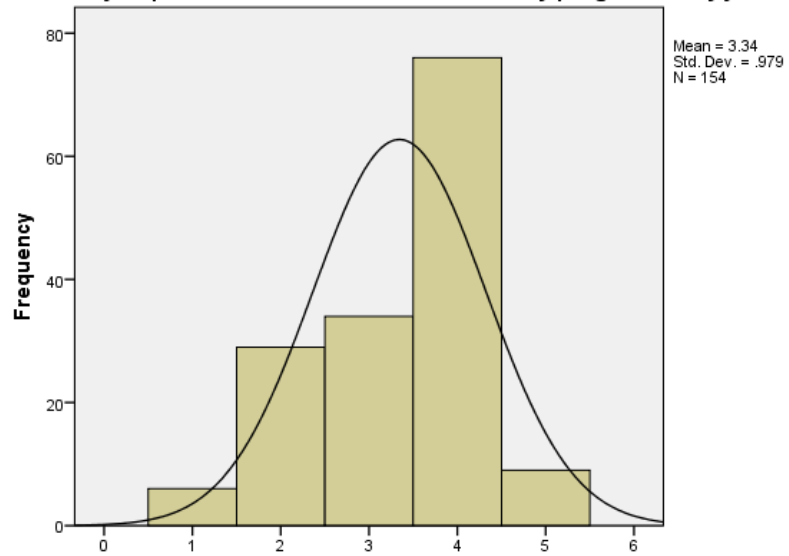

Listed below are several kinds of information often associated with a person's job. please indica...-  
Information about my progress in my job1

Listed below are several kinds of information often associated with a person's job. please indica...-Personal news 2

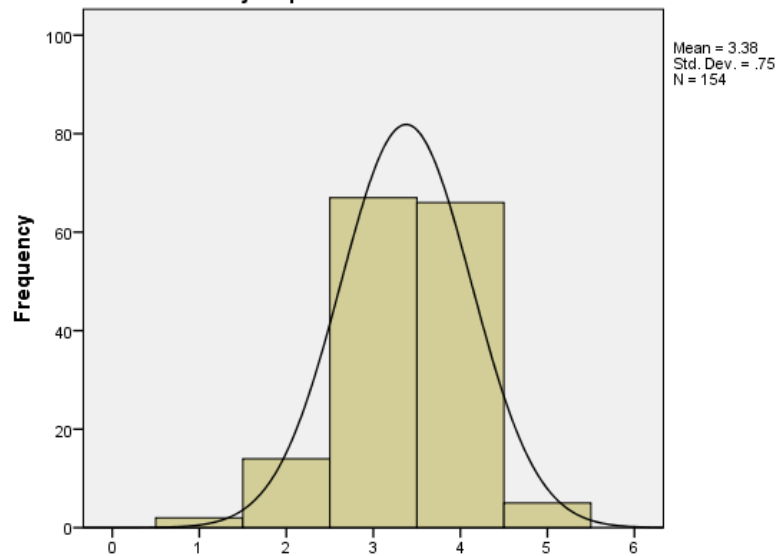

Listed below are several kinds of information often associated with a person's job. please indica...-  
Personal news 2

Listed below are several kinds of information often associated with a person's job. please indica...-Information about benefits and pay3

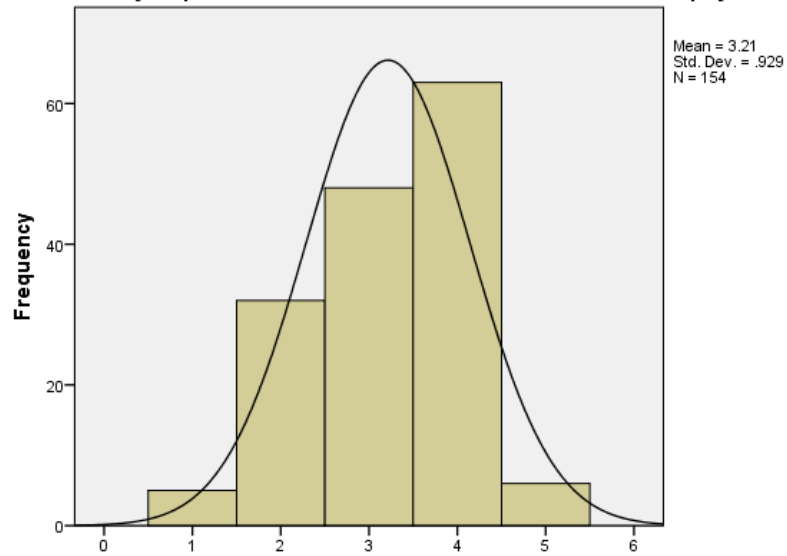

Listed below are several kinds of information often associated with a person's job. please indica...- Information about benefits and pay3

Listed below are several kinds of information often associated with a person's job. please indica...-Information about the requirements of my job4



Listed below are several kinds of information often associated with a person's job. please indica...- Information about the requirements of my job4

Listed below are several kinds of information often associated with a person's job. please indica...-Information about departmental policies and goals5

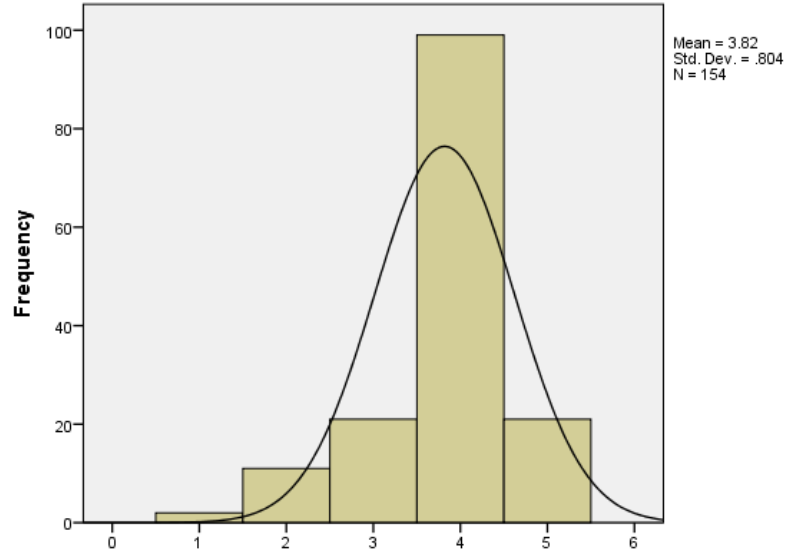

Listed below are several kinds of information often associated with a person's job. please indica...-Information about departmental policies and goals5

Listed below are several kinds of information often associated with a person's job. please indica...-information about organisational policies and goals6

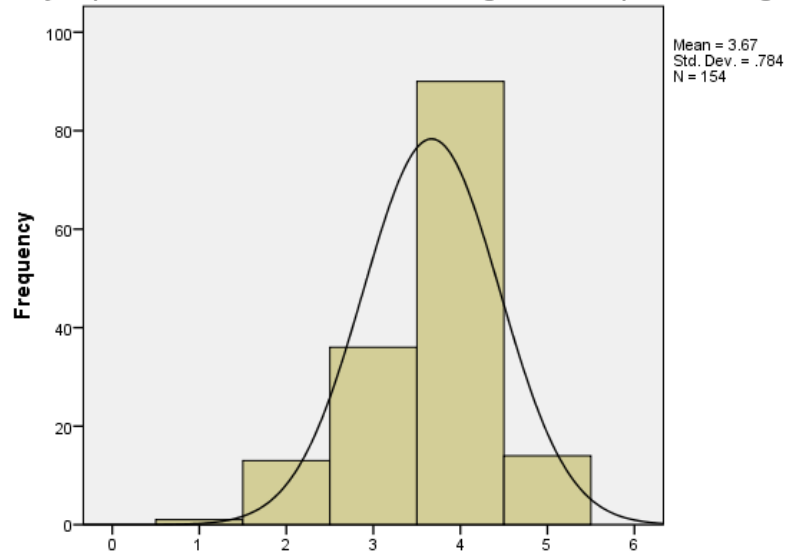

Listed below are several kinds of information often associated with a person's job. please indica...-information about organisational policies and goals6

Listed below are several kinds of information often associated with a person's job. please indica...-Information about changes in our organisation7

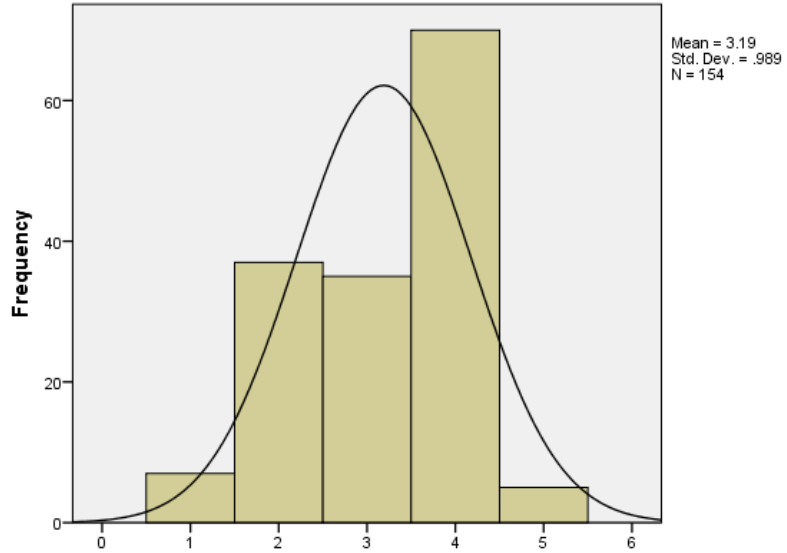

Listed below are several kinds of information often associated with a person's job. please indica...- Information about changes in our organisation7

Listed below are several kinds of information often associated with a person's job. please indica...-Information about government action affecting my organisation8

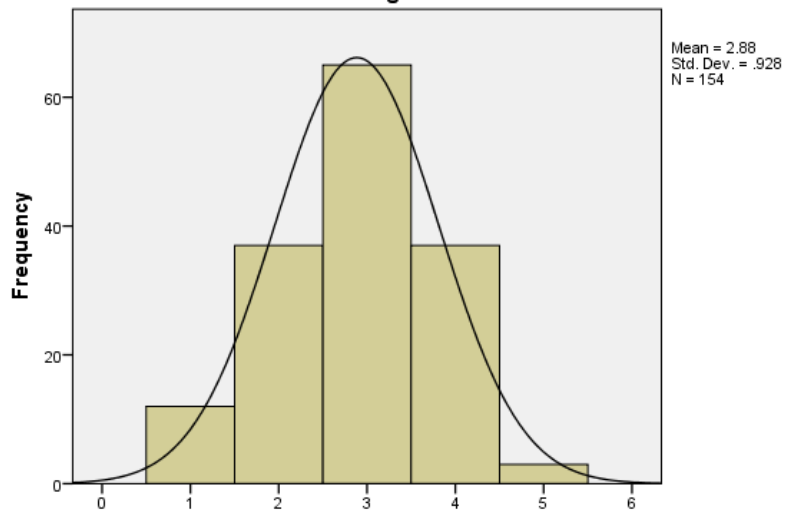

Listed below are several kinds of information often associated with a person's job. please indica...- Information about government action affecting my organisation8

Listed below are several kinds of information often associated with a person's job. please indica...-Information about our organisations financial standing9

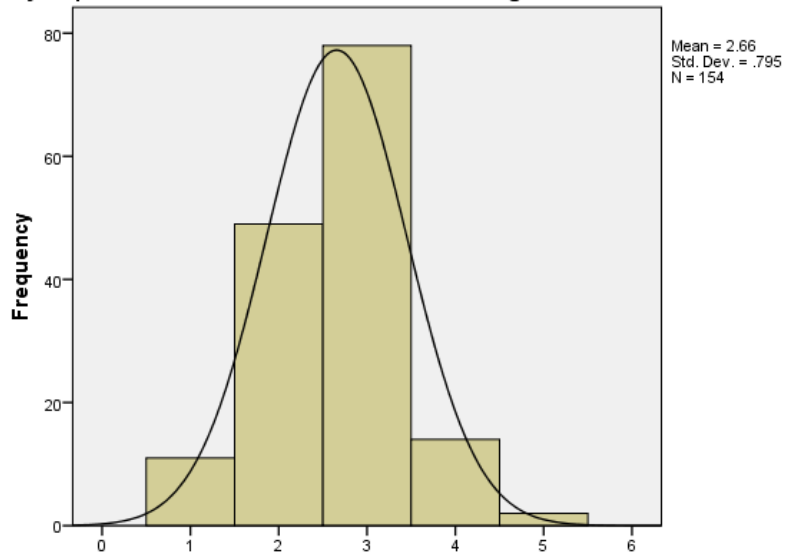

Listed below are several kinds of information often associated with a person's job. please indica...-Information about our organisations financial standing9

Listed below are several kinds of information often associated with a person's job. please indica...-Information about accomplishments and/or failures of the organisation10

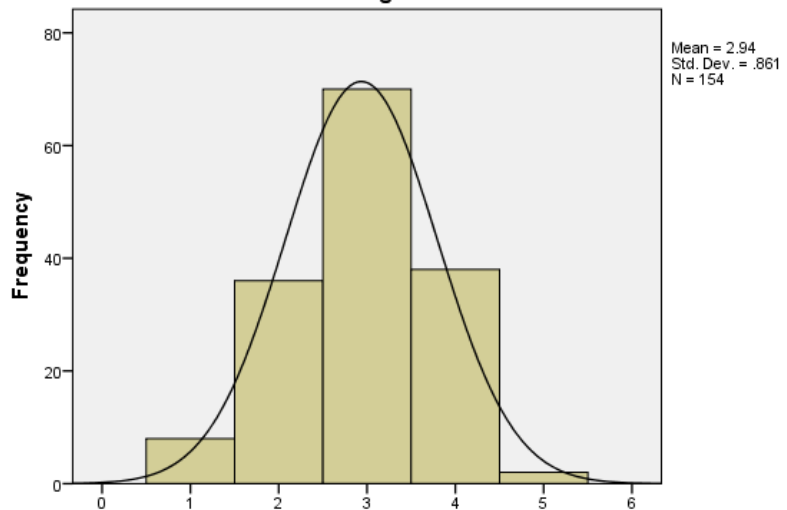

Listed below are several kinds of information often associated with a person's job. please indica...-Information about accomplishments and/or failures of the organisation10

Please indicate how satisfied you are with the following (tick the appropriate number )-Extent to which my supervisor listens and pays attention to me11

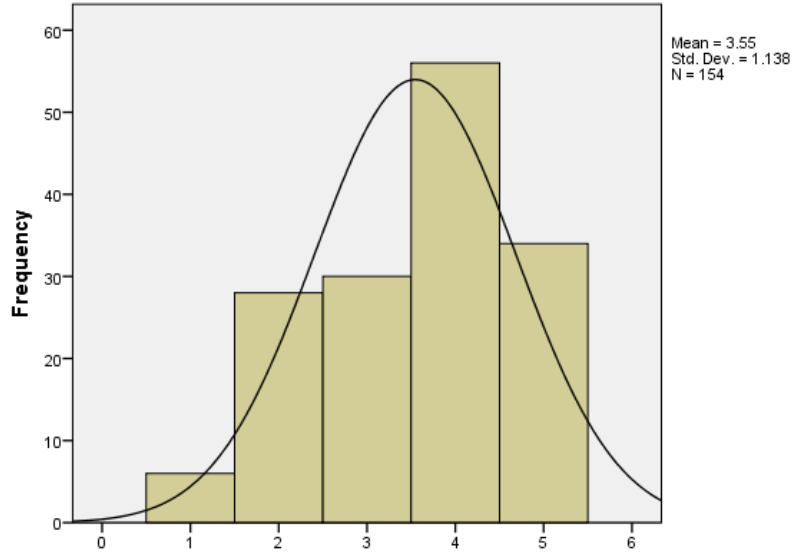

Please indicate how satisfied you are with the following (tick the appropriate number )-Extent to which my supervisor listens and pays attention to me11

Please indicate how satisfied you are with the following (tick the appropriate number )-Extent to which my supervisor offers guidance for solving job related problems12

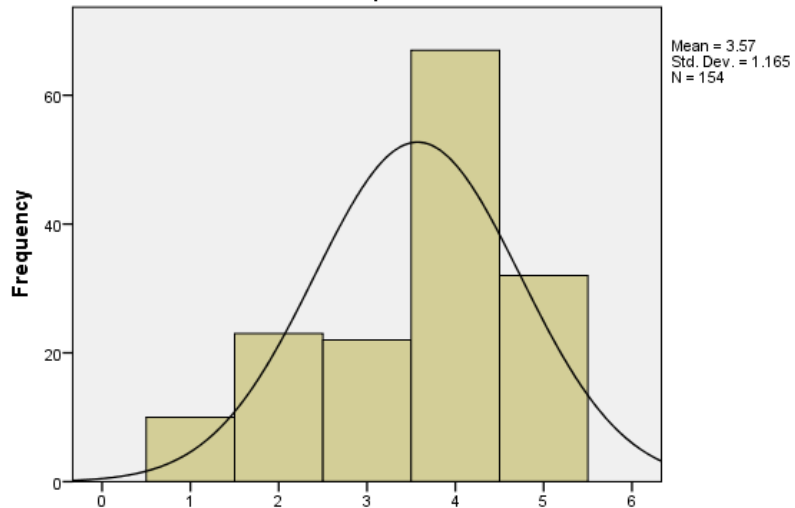

Please indicate how satisfied you are with the following (tick the appropriate number )-Extent to which my supervisor offers guidance for solving job related problems12



Please indicate how satisfied you are with the following (tick the appropriate number )-Extent to which my supervisor trusts me13

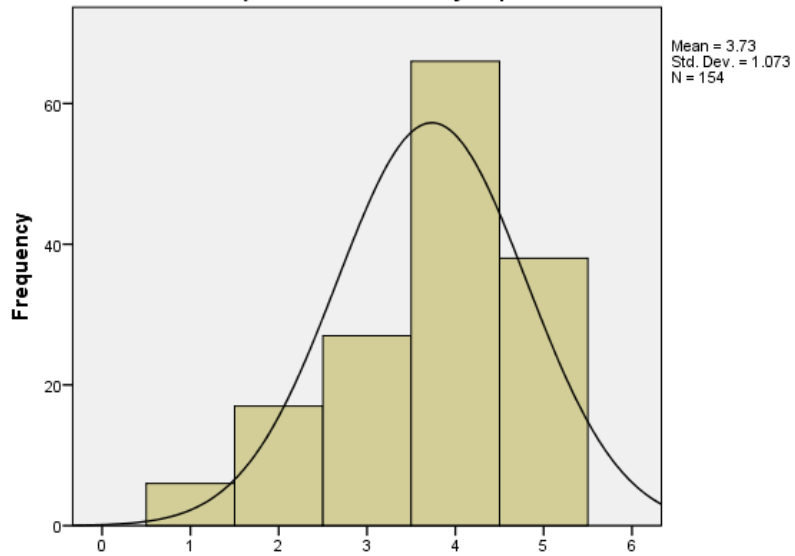

Please indicate how satisfied you are with the following (tick the appropriate number )-Extent to which my supervisor trusts me13

Please indicate how satisfied you are with the following (tick the appropriate number )-Extent to which the amount of supervision given me is about right14

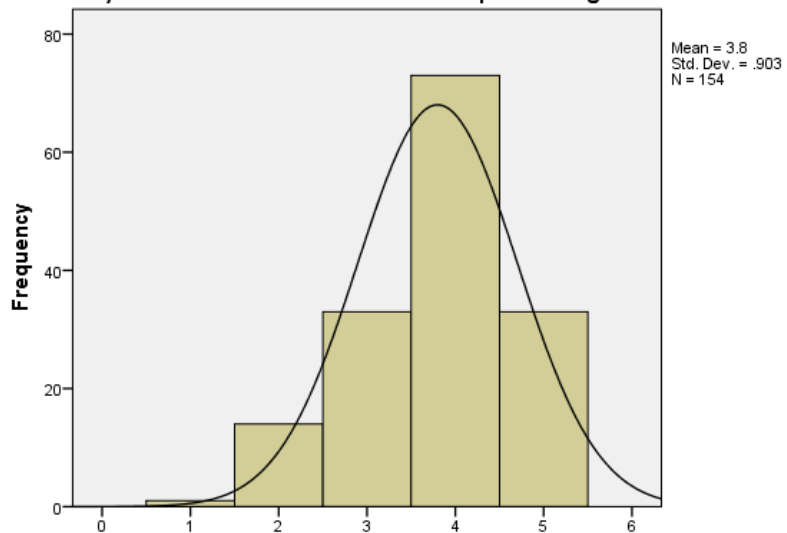

Please indicate how satisfied you are with the following (tick the appropriate number )-Extent to which the amount of supervision given me is about right14

Please indicate how satisfied you are with the following (tick the appropriate number )-Extent to which my supervisor is open to ideas15

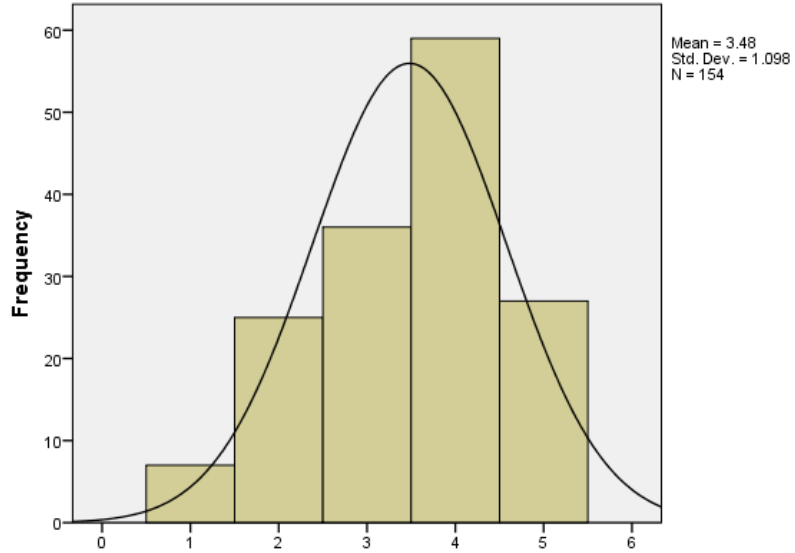

Please indicate how satisfied you are with the following (tick the appropriate number )-Extent to which my supervisor is open to ideas15

Please indicate how satisfied you are with the following (tick the appropriate number )-Extent to which the people in my organisation have great ability as communicators16

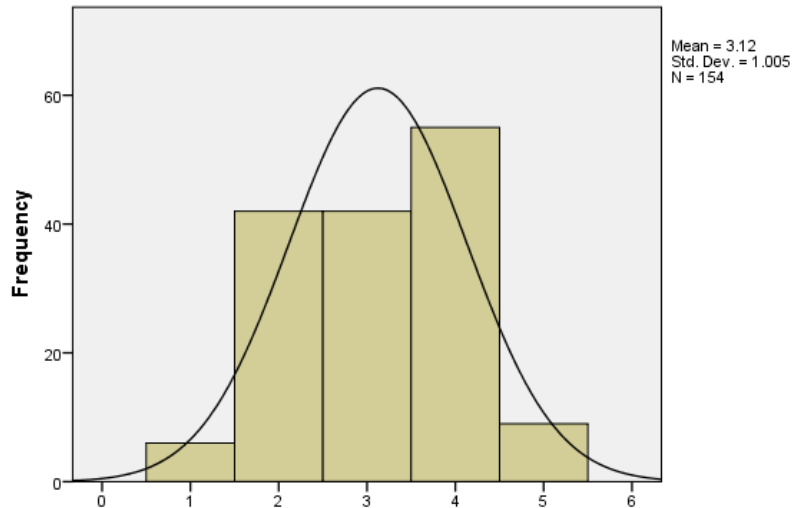

Please indicate how satisfied you are with the following (tick the appropriate number )-Extent to which the people in my organisation have great ability as communicators16

Please indicate how satisfied you are with the following (tick the appropriate number )-Extent to which I receive, in time, the information needed to do my job17

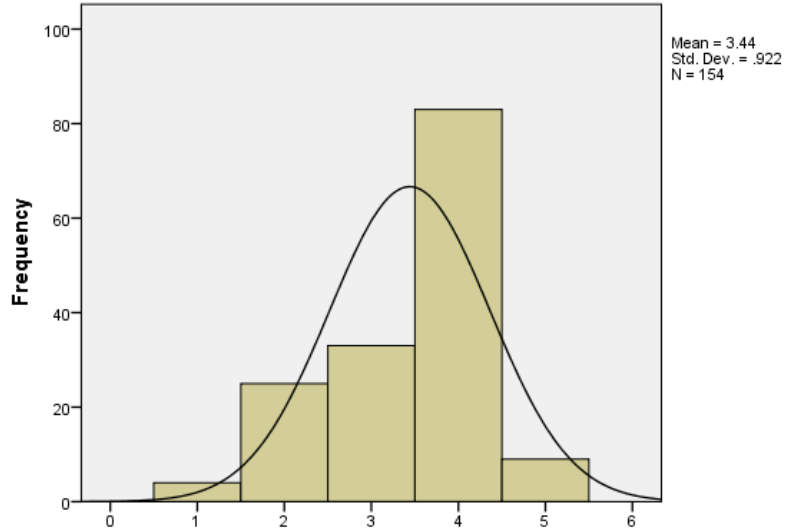

Please indicate how satisfied you are with the following (tick the appropriate number )-Extent to which I receive, in time, the information needed to do my job17

Please indicate how satisfied you are with the following (tick the appropriate number )-Extent to which conflicts are handled appropriately through proper communication channels18

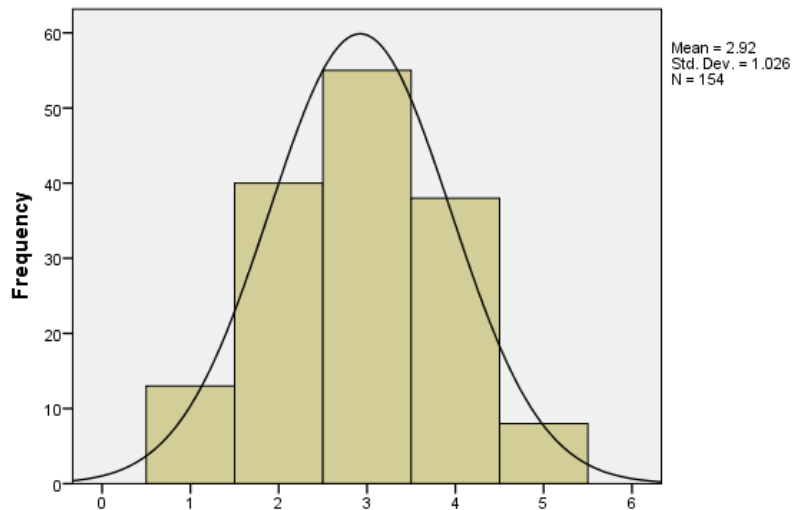

Please indicate how satisfied you are with the following (tick the appropriate number )-Extent to which conflicts are handled appropriately through proper communication channels18

Please indicate how satisfied you are with the following (tick the appropriate number )-Extent to which the organisation's communication make me identify with or feel a vital part of it<sup>19</sup>

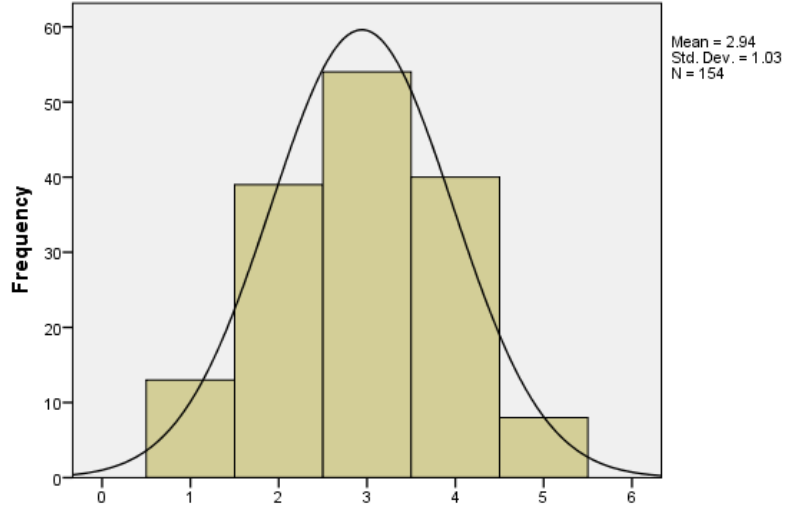

Please indicate how satisfied you are with the following (tick the appropriate number )-Extent to which the organisation's communication make me identify with or feel a vital part of it<sup>19</sup>

Please indicate how satisfied you are with the following (tick the appropriate number )-Extent to which the organisation's communication motivates and stimulates an enthusiasm for meeting its goals<sup>20</sup>

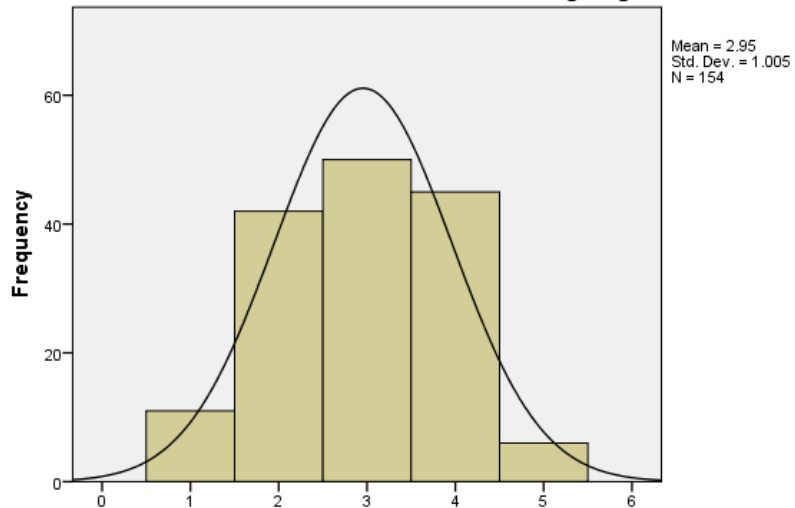

Please indicate how satisfied you are with the following (tick the appropriate number )-Extent to which the organisation's communication motivates and stimulates an enthusiasm for meeting its goals<sup>20</sup>

Please indicate how satisfied you are with the following (tick the appropriate number )-Extent to which horizontal (peers, CN-CN, RN-RN) communication with other organisational members is accurate and free flowing21

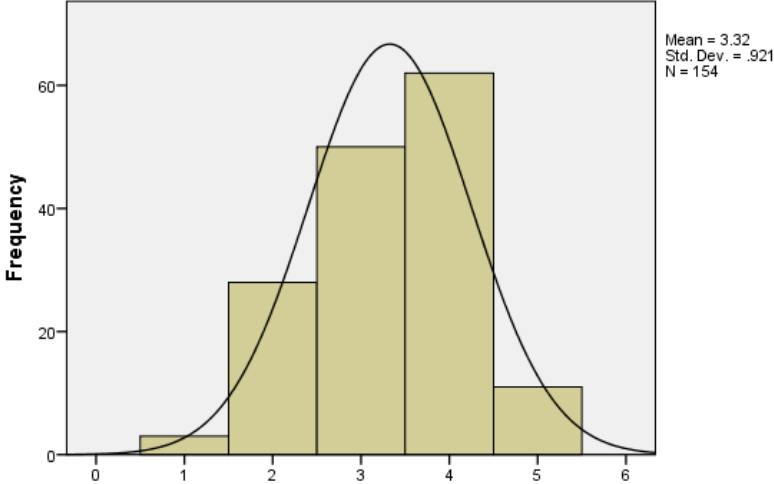

Please indicate how satisfied you are with the following (tick the appropriate number )-Extent to which horizontal (peers, CN-CN, RN-RN) communication with other organisational members is accurate and free flowing21

Please indicate how satisfied you are with the following (tick the appropriate number )-Extent to which communication practices are adaptable to emergencies22

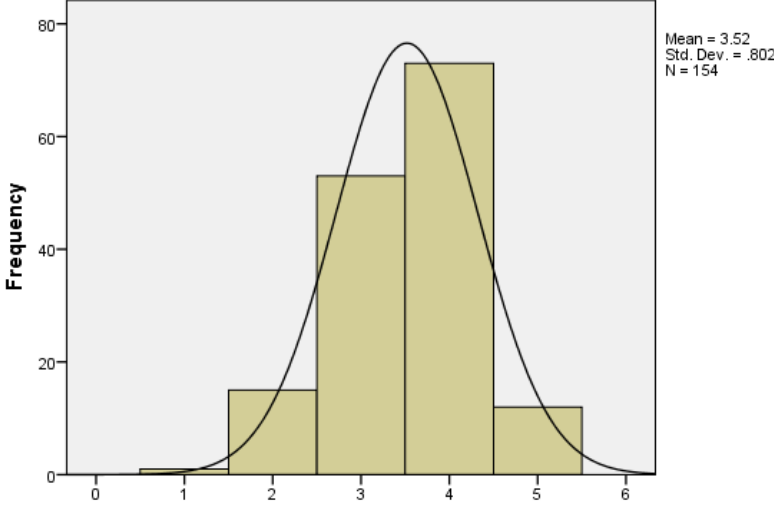

Please indicate how satisfied you are with the following (tick the appropriate number )-Extent to which communication practices are adaptable to emergencies22

Please indicate how satisfied you are with the following (tick the appropriate number )-Extent to which my work group is compatible23

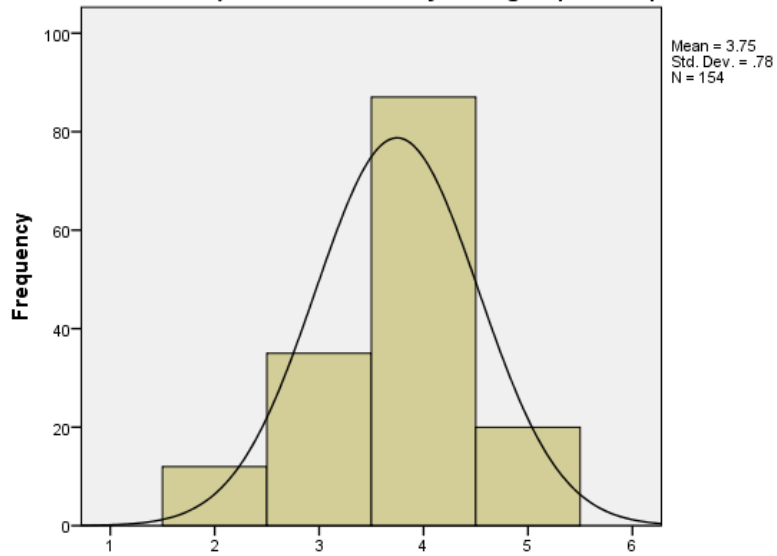

Please indicate how satisfied you are with the following (tick the appropriate number )-Extent to which my work group is compatible23

Please indicate how satisfied you are with the following (tick the appropriate number )-Extent to which informal communication is accurate and active (Informal communication refers to social relationships24

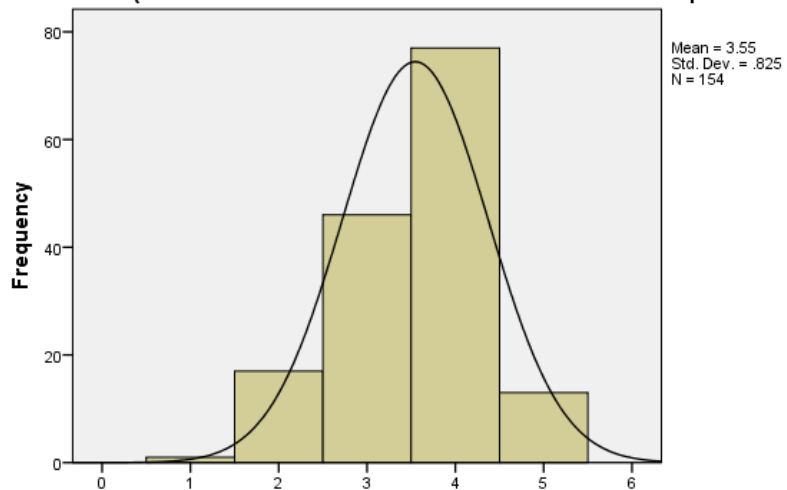

Please indicate how satisfied you are with the following (tick the appropriate number )-Extent to which informal communication is accurate and active (Informal communication refers to social relationships24

Please indicate how satisfied you are with the following (tick the appropriate number )-Extent to which thegrapevine is active in our organisation25

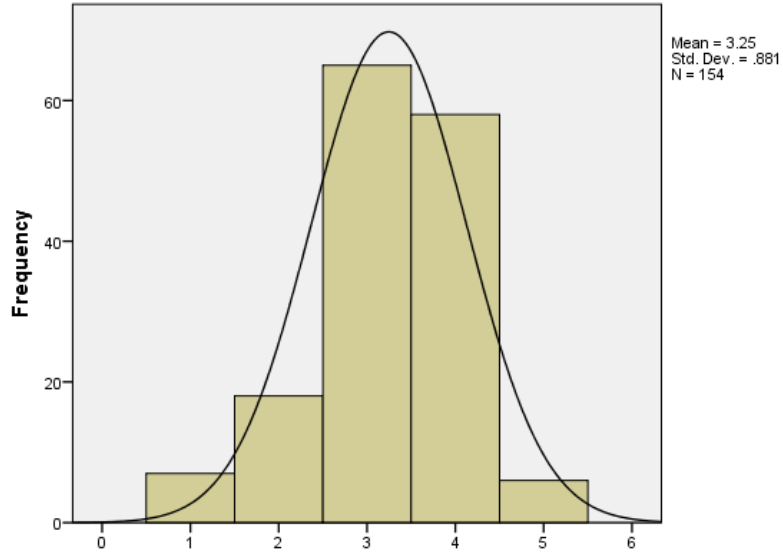

Please indicate how satisfied you are with the following (tick the appropriate number )-Extent to which thegrapevine is active in our organisation25

Please indicate how satisfied you are with the following (tick the appropriate number )-Extent to which written directives and reports are clear and concise26

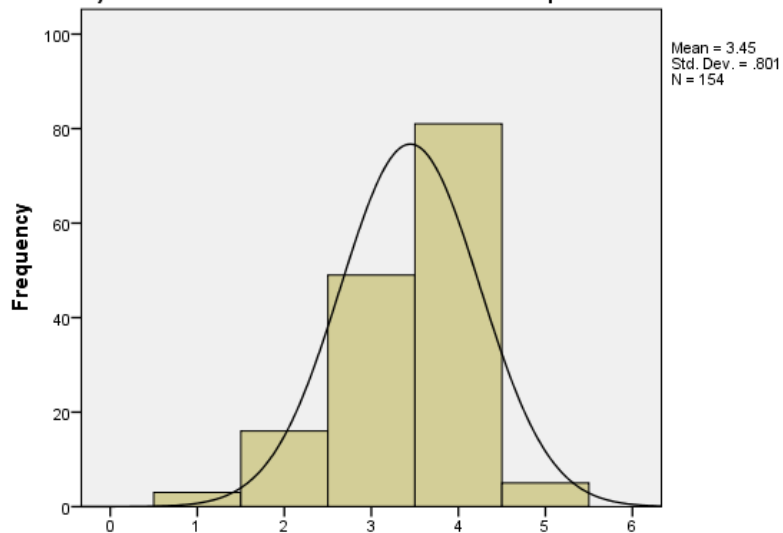

Please indicate how satisfied you are with the following (tick the appropriate number )-Extent to which written directives and reports are clear and concise26

Please indicate how satisfied you are with the following (tick the appropriate number )-Extent to which the attitudes toward communication in the organisation are basically healthy27

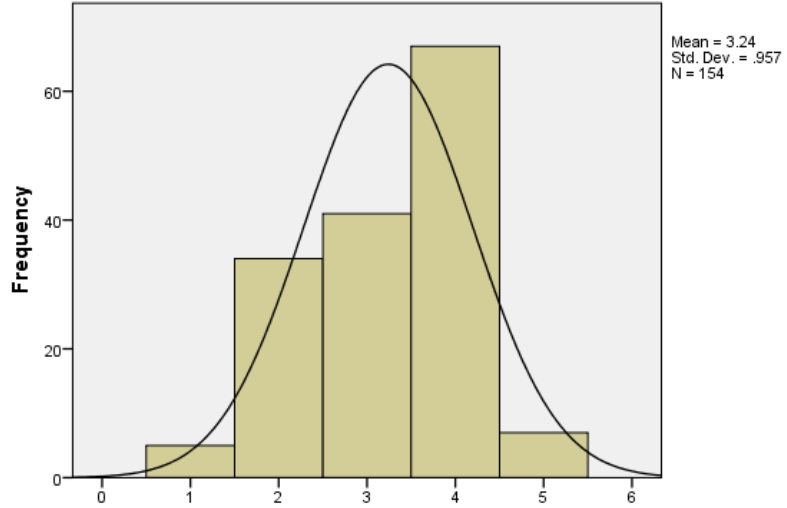

Please indicate how satisfied you are with the following (tick the appropriate number )-Extent to which the attitudes toward communication in the organisation are basically healthy27

Please indicate how satisfied you are with the following (tick the appropriate number )-Extent to which our meetings are well organised28

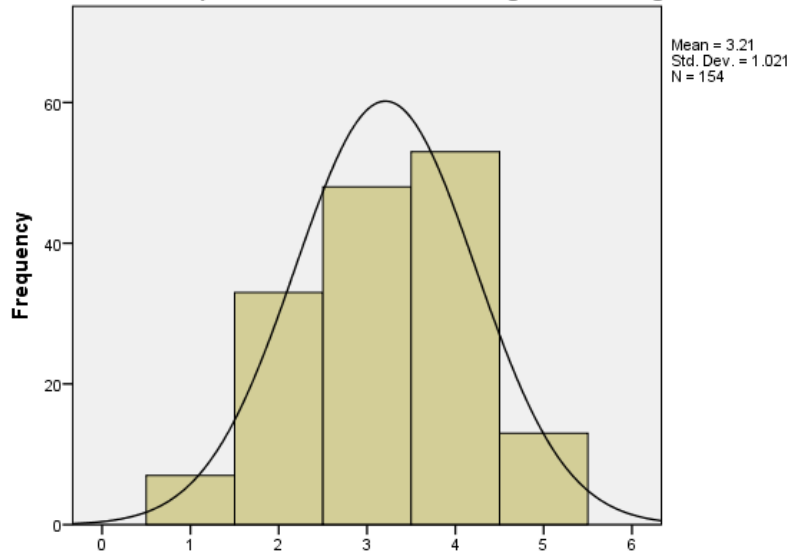

Please indicate how satisfied you are with the following (tick the appropriate number )-Extent to which our meetings are well organised28



Please indicate how satisfied you are with the following (tick the appropriate number )-Extent to which the amount of communication in the organisation is about right29

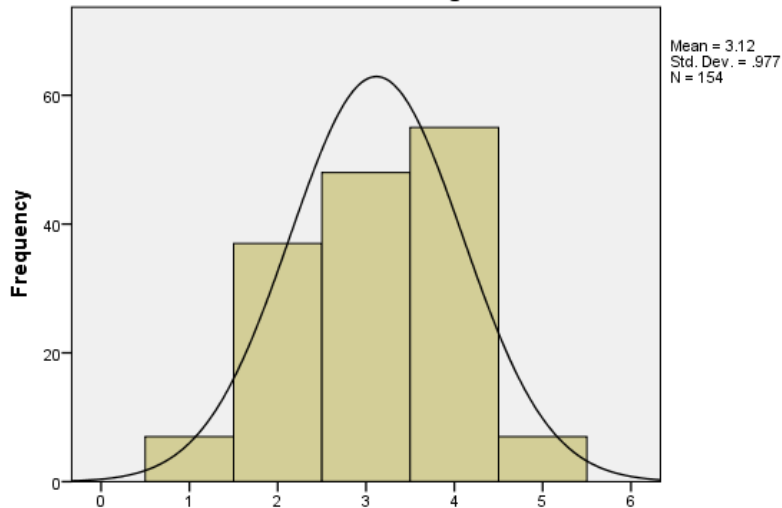

Please indicate how satisfied you are with the following (tick the appropriate number )-Extent to which the amount of communication in the organisation is about right29

Please indicate how satisfied you are with the following (tick the appropriate number )-Extent to which the organisation's communication are interesting and helpful30

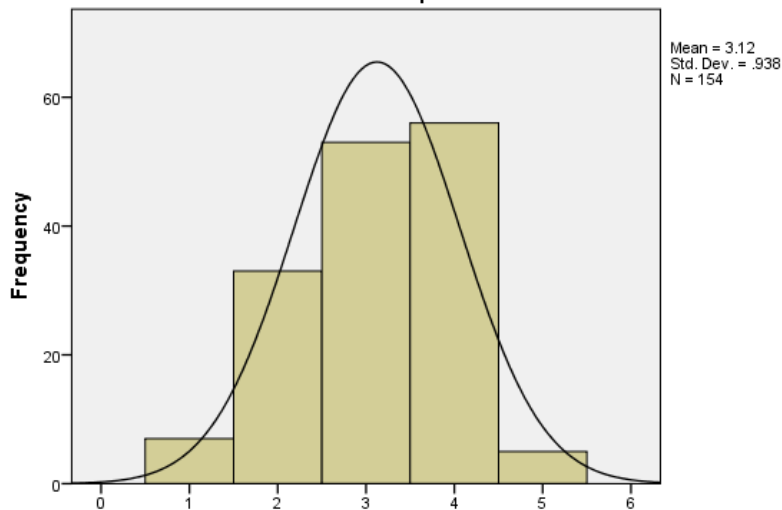

Please indicate how satisfied you are with the following (tick the appropriate number )-Extent to which the organisation's communication are interesting and helpful30

The following questions are related to various aspects of your job. Please indicate how satisfied...-The physical conditions in which you work

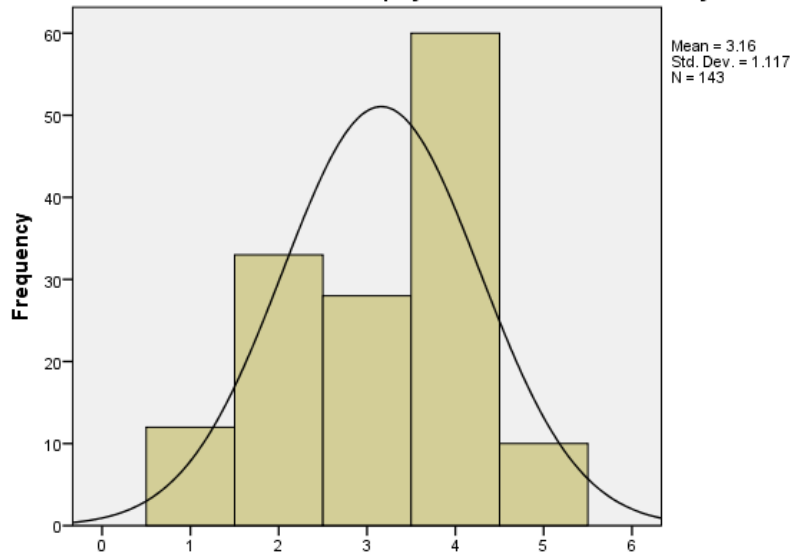

The following questions are related to various aspects of your job. Please indicate how satisfied...-The physical conditions in which you work

The following questions are related to various aspects of your job. Please indicate how satisfied...-Freedom to choose your own working methods

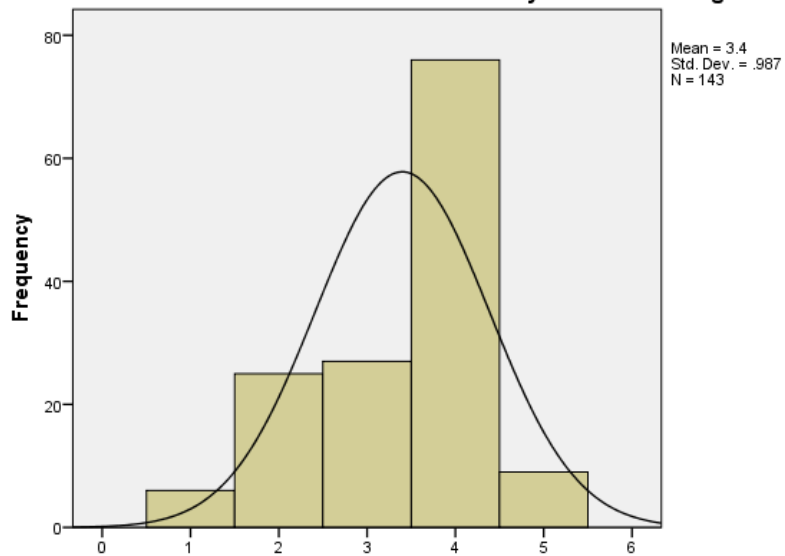

The following questions are related to various aspects of your job. Please indicate how satisfied...-Freedom to choose your own working methods

The following questions are related to various aspects of your job. Please indicate how satisfied...-Your fellow workers

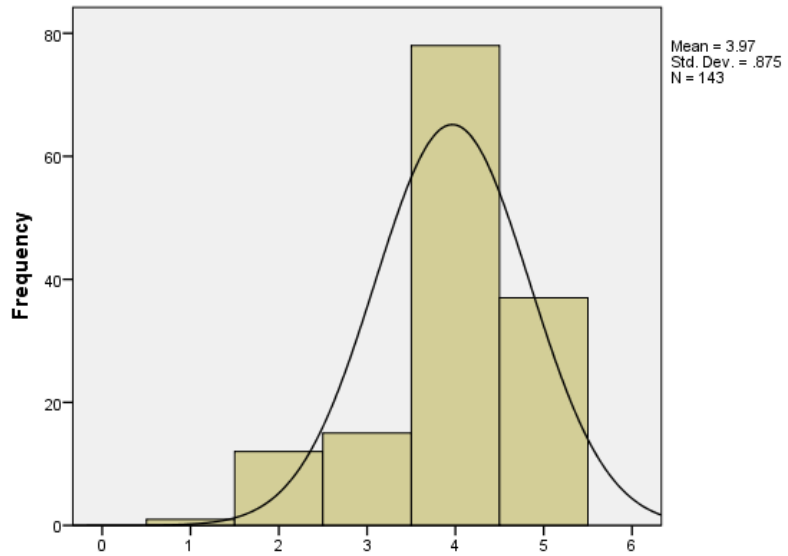

The following questions are related to various aspects of your job. Please indicate how satisfied...-Your fellow workers

The following questions are related to various aspects of your job. Please indicate how satisfied...-The recognition you get for good work

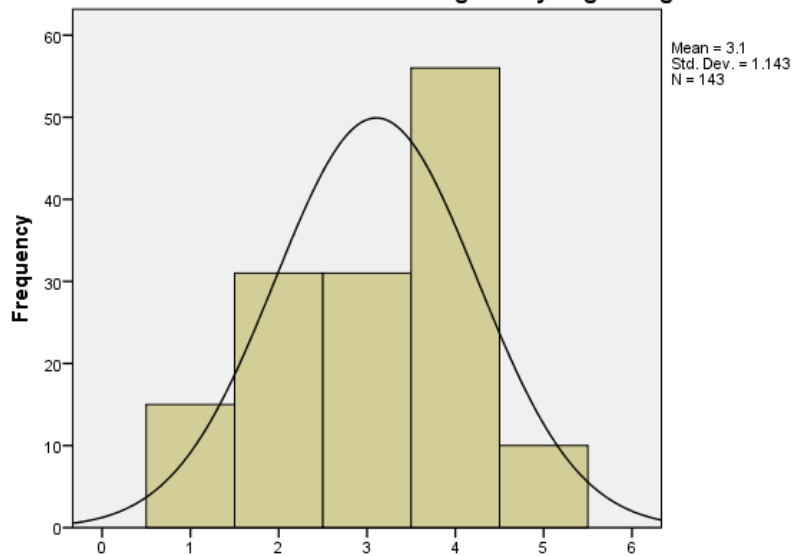

The following questions are related to various aspects of your job. Please indicate how satisfied...-The recognition you get for good work

The following questions are related to various aspects of your job. Please indicate how satisfied...-Your immediate manager

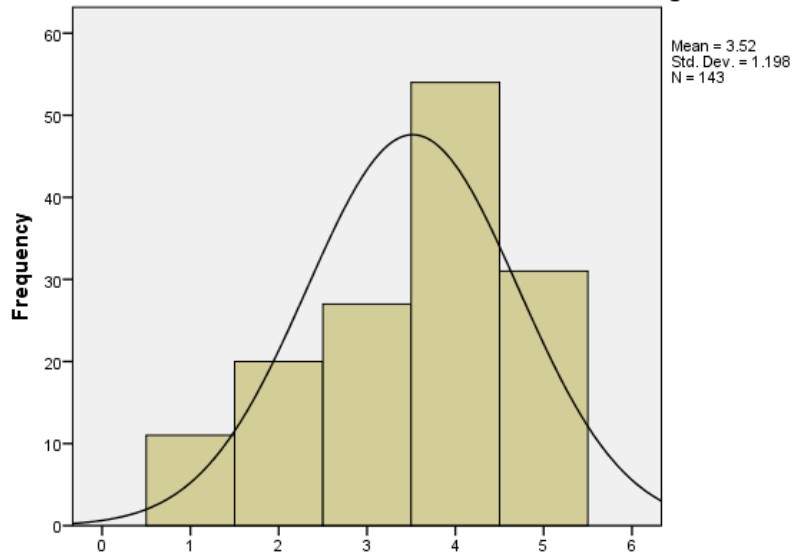

The following questions are related to various aspects of your job. Please indicate how satisfied...-Your immediate manager

The following questions are related to various aspects of your job. Please indicate how satisfied...-The amount of responsibility you are given

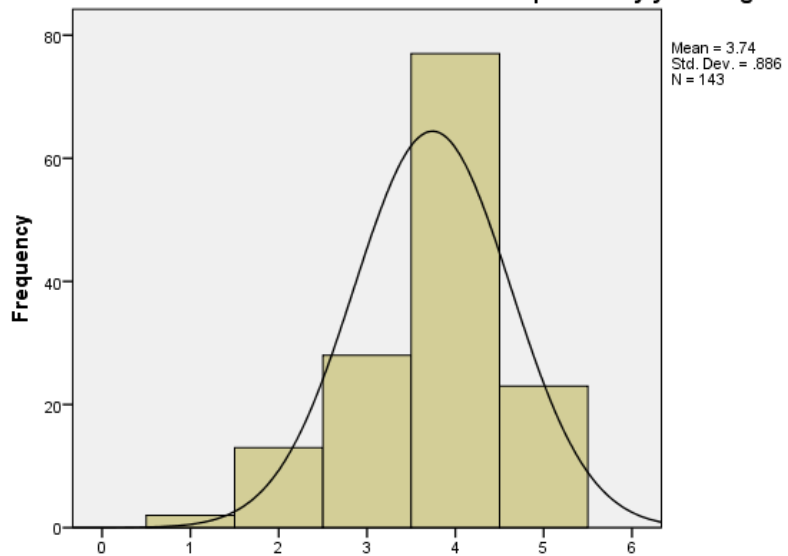

The following questions are related to various aspects of your job. Please indicate how satisfied...-The amount of responsibility you are given

The following questions are related to various aspects of your job. Please indicate how satisfied...-The rate of pay for nurses

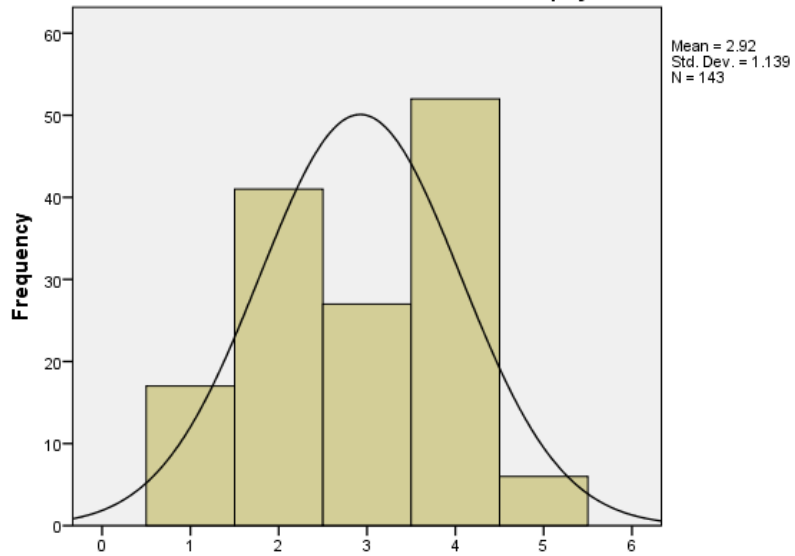

The following questions are related to various aspects of your job. Please indicate how satisfied...-The rate of pay for nurses

The following questions are related to various aspects of your job. Please indicate how satisfied...-The opportunity to use your abilities

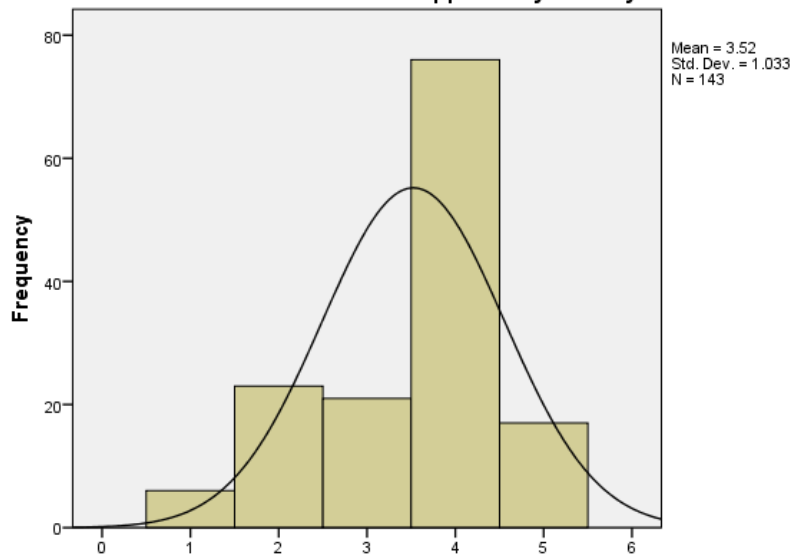

The following questions are related to various aspects of your job. Please indicate how satisfied...-The opportunity to use your abilities

The following questions are related to various aspects of your job. Please indicate how satisfied...-Relations between management and staff

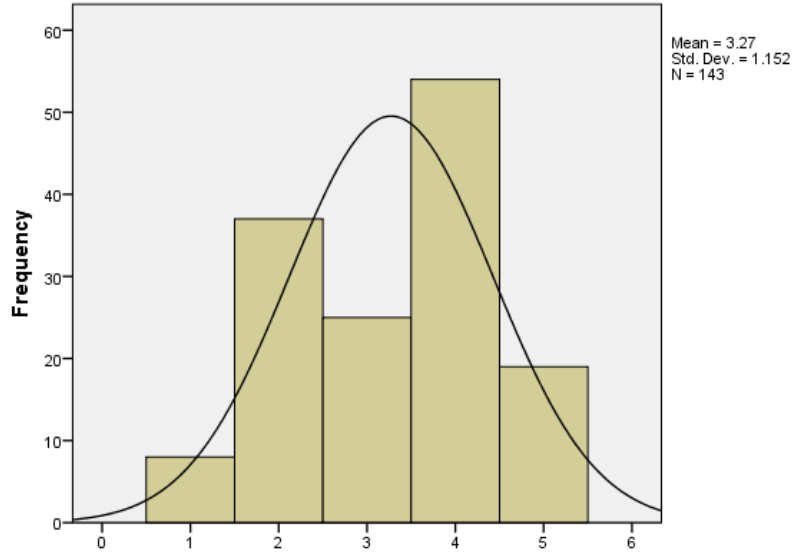

The following questions are related to various aspects of your job. Please indicate how satisfied...-Relations between management and staff

The following questions are related to various aspects of your job. Please indicate how satisfied...-Future chance of promotion

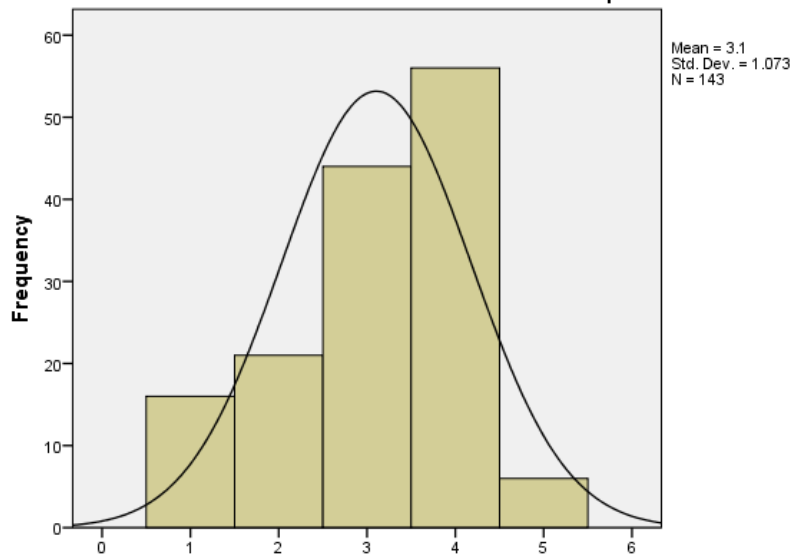

The following questions are related to various aspects of your job. Please indicate how satisfied...-Future chance of promotion

The following questions are related to various aspects of your job. Please indicate how satisfied...-The way the hospital is managed

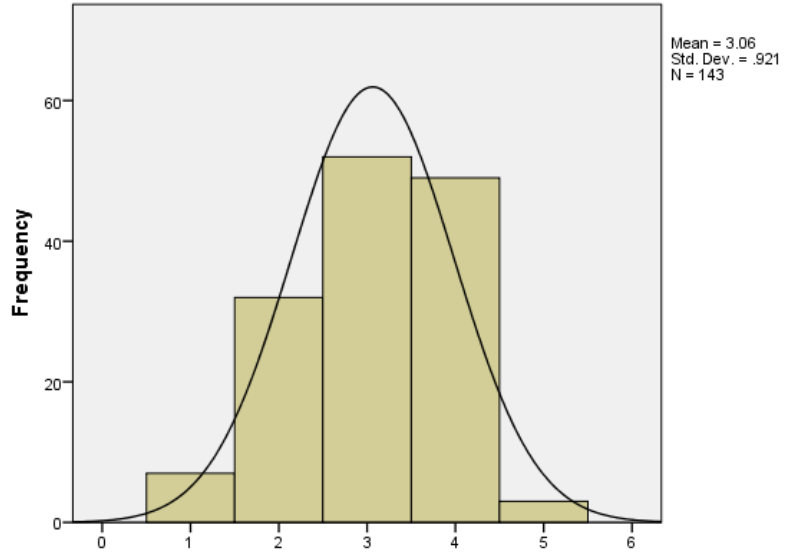

The following questions are related to various aspects of your job. Please indicate how satisfied...-The way the hospital is managed

The following questions are related to various aspects of your job. Please indicate how satisfied...-The attention paid to your suggestions

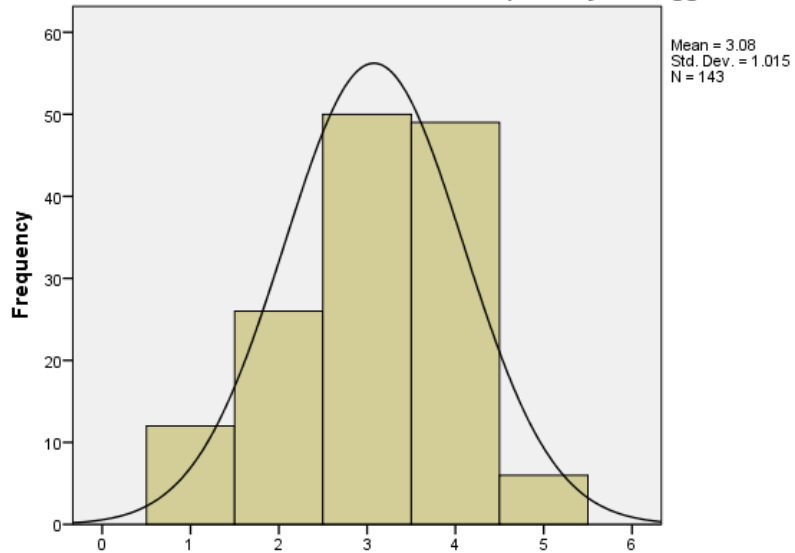

The following questions are related to various aspects of your job. Please indicate how satisfied...-The attention paid to your suggestions

The following questions are related to various aspects of your job. Please indicate how satisfied...-The hours of work

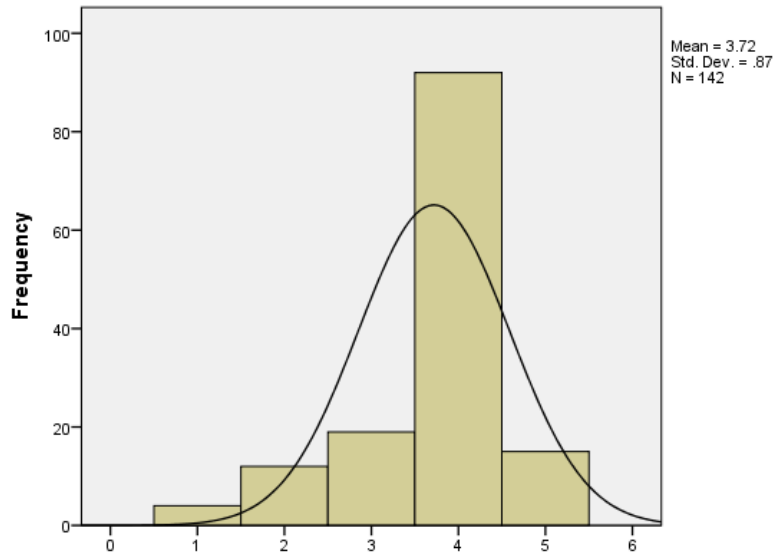

The following questions are related to various aspects of your job. Please indicate how satisfied...-The hours of work

The following questions are related to various aspects of your job. Please indicate how satisfied...-The amount of variety in your job

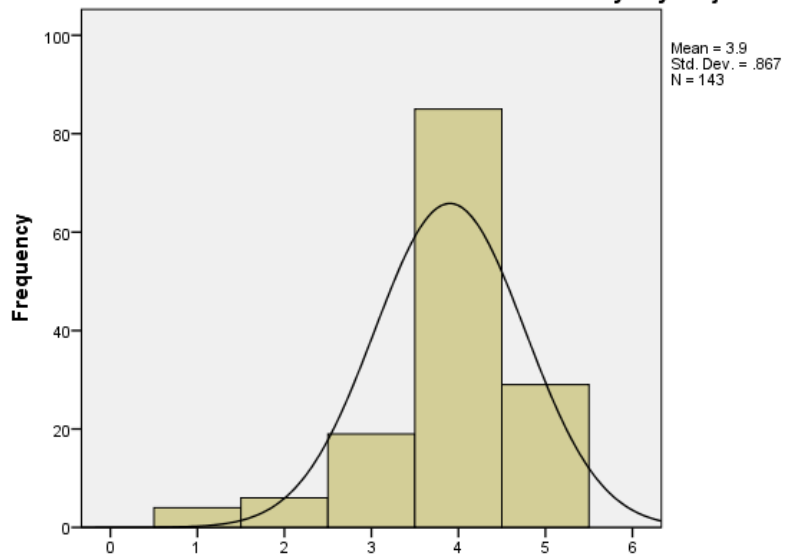

The following questions are related to various aspects of your job. Please indicate how satisfied...-The amount of variety in your job



The following questions are related to various aspects of your job. Please indicate how satisfied...-Your security

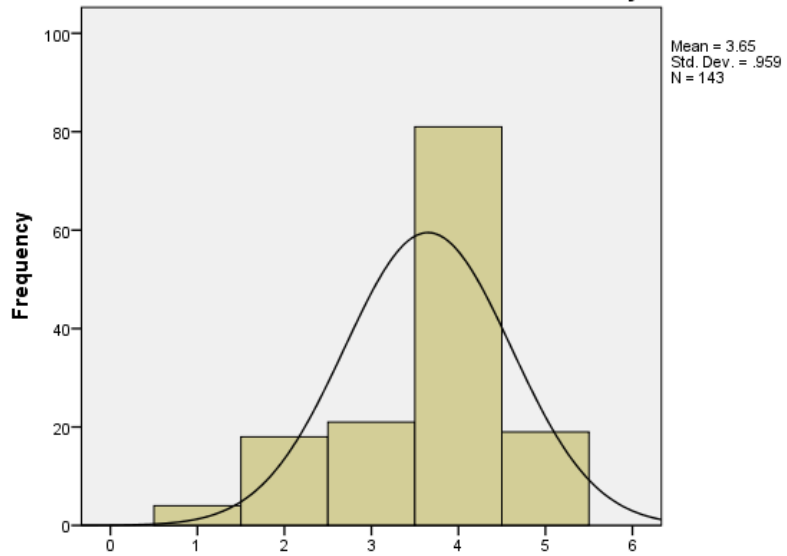

The following questions are related to various aspects of your job. Please indicate how satisfied...-Your security

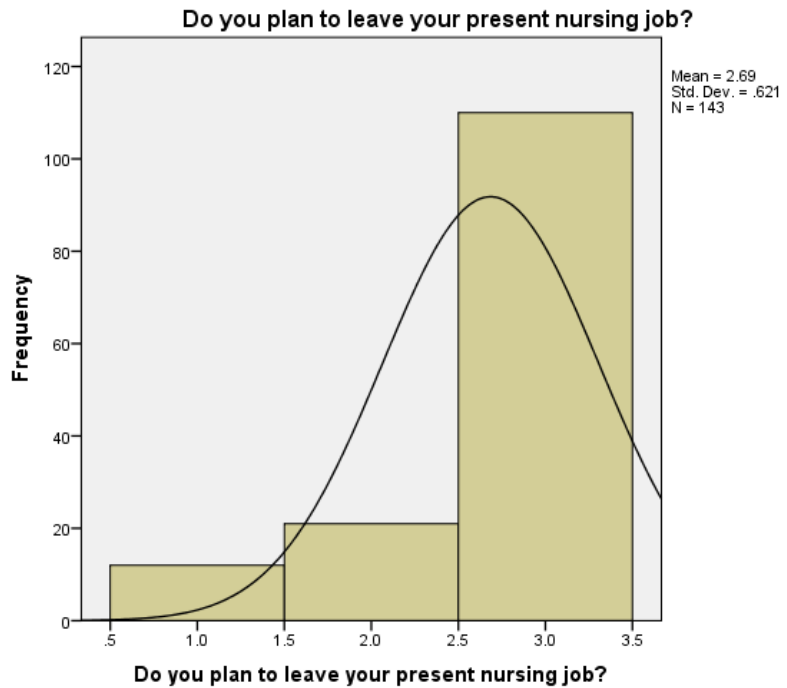

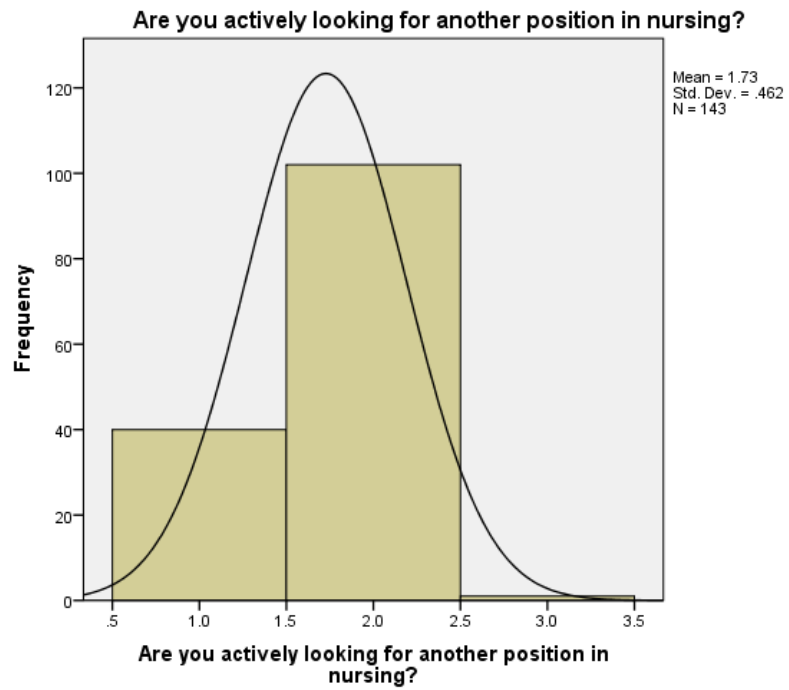

**If you are/were looking for another job how easy or difficult do you think it would be for you t...**



# APPENDIX B: INFORMATION SHEET

FORM 3A



Government of Western Australia  
Department of Health  
Child and Adolescent Health Service

## INFORMATION SHEET

### Phase 1 Questionnaire Data Collection

#### The impact of communication satisfaction on paediatric nurses job satisfaction and intention to stay.

##### Why are we doing the study?

We are doing the study to explore how paediatric nurses and middle managers feel about communication within the organisation and how the communication affects paediatric nurses' job satisfaction and intention to stay in the job and in the nursing profession. It is known that poor communication results in poor performance and lower levels of patient care, poor collaboration and teamwork and poor commitment from managers, which results in lower job satisfaction among nurses and more nursing wanting to leave their jobs and the nursing profession. Whilst there is a documented connection between job satisfaction, work commitment and communication, this has not been studied in nursing in the last two decades and not in relation to paediatric nurses and middle managers. This research project focuses on organisational communication satisfaction of middle managers and paediatric nurses and looks at the effect this communication satisfaction has on paediatric nurses' job satisfaction and intention to stay in the job and in the nursing profession. The study will be separated into two distinct Phases. This information sheet is related to Phase one of the study and will involve the collection of data through a questionnaire. 605 participants will be invited to fill in the questionnaires. Phase two of the research study will involve interviews and focus group discussions with the researcher. Participants for Phase two of the study will be recruited separately.

##### Who is carrying out the study?

This study is being conducted for a Doctoral thesis by Gemma Evans.

##### What will the study tell us?

It is hoped that this study will allow for recommendations to be made that may improve organisational communication. It is also hoped that a relationship between nurses' and managers' organisational communication satisfaction, nurses' job satisfaction and their intention to stay in their job and in nursing will be identified.

##### Do I have to take part?

Participation in this study is entirely voluntary: you are in no way obliged to participate and if you do participate - you can withdraw at any time. Whatever your decision, please be assured that it will not affect your relationship with your employer or ECU. There will be no cost to you and you will not be paid for taking part in this study.



**What will you be asked to do if you decide to take part in this study?**

You will need to complete a questionnaire via the software package Qualtrics™ by inserting the following URL into an internet webpage [https://ecuau.qualtrics.com/SE/?SID=SV\\_4Si56rIPkvbbeRL](https://ecuau.qualtrics.com/SE/?SID=SV_4Si56rIPkvbbeRL) or via hard copy. This takes approximately 15 mins to complete. The researcher will give you a copy of the questionnaire if you prefer to complete it in that way. The questionnaire will include non-identifying employment characteristics such as length of employment, questions related to your current view on communication of information at the hospital and your job satisfaction and intention to stay in your job and in the profession.

**Is there likely to be a benefit to myself?**

There is likely to be no immediate benefit to you, however, the study will give you the opportunity to confidentially express your perception of organisational communication at PMH through a questionnaire.

**Is there likely to be a benefit to other people in the future?**

It is hoped that this study will bring to light factors that enhance and hinder organisational communication satisfaction and in doing so will allow for recommendations to be made that may improve organisational communication; and in turn may improve job satisfaction aiding nursing retention strategies.

**What are the possible risks and/or side effects?**

It is possible that you may feel emotionally distressed or uncomfortable during or after completion of the questionnaires. If you find that completion of the questionnaire makes you uncomfortable in any way, please notify the researcher.

**Where is your information kept?**

The data will be stored according to NHMRC guidelines (National Health and Medical Research Council, 2007) on a password protected computer with access only permitted to the researcher. The data will be stored in a secure place for 5 years, after which time it will be destroyed in a safe and secure manner. The results of this study will be presented in the form of a report to PMH and to ECU at the completion of the data analysis phases.

**What about my privacy?**

All identifying results and data will be kept confidential and only the investigators will have access to your information. We will ask you not to disclose any patient sensitive information whilst completing the questionnaires. However, if any such information is disclosed it will be kept strictly confidential and will not be reported or published. A report of the study will be



presented, submitted and examined by Edith Cowan University and Princess Margaret Hospital, but individual participants and wards will not be identifiable in such a report.

**Who has approved the study?**

This study has been approved by Edith Cowan University Human Research Ethics Committee (HREC). If you have any complaints or reservations about any aspect of your participation in this research, which you cannot resolve with the researcher you may contact the the Research Ethics Officer at ECU, on (08) 6304 2170. The funding for this study has been provided in the way of a PhD resource allocation from Edith Cowan University.

The Princess Margaret Hospital Human Research Ethics Committee and the Child and Adolescent Health Service (CAHS) Division of Clinical Research and Education have also granted approval for the conduct of this study and will be monitoring the study to ensure that terms of approval and monitoring are met. If you have any concerns about the ethics or code of practice of this study, you may also contact the Executive Officer of the Princess Margaret Hospital Human Research Ethics Committee on (08) 9340 8221 or the research governance office on (08) 9340 7108

**Who to contact for more information about this study:**

If you would like any more information about this study, please do not hesitate to contact one of the research team. They are very happy to answer your questions.

<b>Name</b> Gemma Evans	<b>Title</b> Mrs	<b>Contact Number</b> 0421255741
<b>Name</b> Di Twigg	<b>Title</b> Professor	<b>Contact Number</b> (08) 6304 2400
<b>Name</b> Sara Bayes	<b>Title</b> Doctor	<b>Contact Number</b> (08) 6304 3508

**Who to contact if you have any concerns about the organisation or running of the study?**

If you have any concerns or complaints regarding this study, you can contact the Director of Medical Services at PMH (Telephone No: (08) 9340 8222). Your concerns will be drawn to the attention of the Ethics Committee who is monitoring the study.

**What to do next if you would like to take part in this research:**

If you would like to take part in Phase one of this research study, please read and sign the consent form provided.

**THANK YOU FOR YOUR TIME**



Phase 2 was not carried out due to time constraints and was deemed unnecessary for the purposes of this study.

---

# APPENDIX C: QUESTIONNAIRE

The impact of communication satisfaction on paediatric nurses job satisfaction and intention to stay



Government of **Western Australia**  
Department of **Health**  
Child and Adolescent Health Service

The literature shows an intrinsic connection between job satisfaction, work commitment and communication. However, nurses' and middle managers satisfaction with organisational communication has not been studied in the last two decades and specifically not in relation to nurses' intention to stay and nurses' job satisfaction. It is important to study organisational communication satisfaction and its effect on nurses' intention to stay and nurses' job satisfaction in order to bridge this gap in the literature and to identify areas and strategies that may aid job satisfaction and nursing retention.

The questionnaire has been approved by the human research ethics committee at Edith Cowan University and Princess Margaret Hospital. Your responses will be completely confidential so be as honest as you like and please do not sign your name on the questionnaire. I appreciate you taking the time to fill in this questionnaire. It will take you 15 minutes to complete.

## Demographics

Q1 What is your gender?

- Female
- Male

Q2 What is your age?

- 18-29
- 30-49
- 50-64
- 65 years and over



v4 04122014



Q3 What are your nursing educational credentials (you may choose more than one option)?

- EN certificate
- RN Hospital certificate
- RN Post-basic certificate
- RN Diploma
- Bachelor degree
- Graduate certificate
- Graduate diploma
- Masters degree
- PhD

Q4 What is your current employment status at the hospital?

- Full time
- Part time
- Casual

Q5 What is your current position?

- EN
- RN
- CN
- SDN
- CNM
- Other \_\_\_\_\_

Q6 What area do you work in?

- General
- Surgical
- Burns
- ICU/CCU
- Operating theaters
- Day stay
- Mental Health
- Emergency department
- Outpatients
- Education
- Management
- Other \_\_\_\_\_



The impact of communication satisfaction on paediatric nurses job satisfaction and intention to stay



Government of **Western Australia**  
 Department of **Health**  
 Child and Adolescent Health Service

Q7 How many years have you been employed in your current position?

- < 1 year
- 1-2 years
- 3-4 years
- 5-6 years
- 7-8 years
- 9-10 years
- 11 years or more

Q8 Listed below are several kinds of information often associated with a person's job.

Please indicate how satisfied you are with the amount and/ or quality of each kind of information by ticking the appropriate response. Please use the following scale to answer the questions.

	Very Dissatisfied	Dissatisfied	Neither satisfied nor dissatisfied	Satisfied	Very Satisfied
Information about my progress in my job	<input type="radio"/>	<input type="radio"/>	<input type="radio"/>	<input type="radio"/>	<input type="radio"/>
Personnel news	<input type="radio"/>	<input type="radio"/>	<input type="radio"/>	<input type="radio"/>	<input type="radio"/>
Information about benefits and pay	<input type="radio"/>	<input type="radio"/>	<input type="radio"/>	<input type="radio"/>	<input type="radio"/>
Information about the requirements of my job	<input type="radio"/>	<input type="radio"/>	<input type="radio"/>	<input type="radio"/>	<input type="radio"/>
Information about departmental policies and goals	<input type="radio"/>	<input type="radio"/>	<input type="radio"/>	<input type="radio"/>	<input type="radio"/>
Information about organisational policies and goals	<input type="radio"/>	<input type="radio"/>	<input type="radio"/>	<input type="radio"/>	<input type="radio"/>
Information about changes in our organisation	<input type="radio"/>	<input type="radio"/>	<input type="radio"/>	<input type="radio"/>	<input type="radio"/>
Information about government action affecting my organisation	<input type="radio"/>	<input type="radio"/>	<input type="radio"/>	<input type="radio"/>	<input type="radio"/>
Information about our organisations financial standing	<input type="radio"/>	<input type="radio"/>	<input type="radio"/>	<input type="radio"/>	<input type="radio"/>
information about accomplishments and/ or failures of the organisation	<input type="radio"/>	<input type="radio"/>	<input type="radio"/>	<input type="radio"/>	<input type="radio"/>



v4 04122014



The impact of communication satisfaction on paediatric nurses job satisfaction and intention to stay



Government of **Western Australia**  
 Department of **Health**  
 Child and Adolescent Health Service

Q9 Please indicate how satisfied you are with the following (tick the appropriate response ).  
 Please use the following scale to answer the questions.

	Very Dissatisfied	Dissatisfied	Neither satisfied nor dissatisfied	Satisfied	Very Satisfied
Extent to which my supervisor listens and pays attention to me	<input type="radio"/>	<input type="radio"/>	<input type="radio"/>	<input type="radio"/>	<input type="radio"/>
Extent to which my supervisor offers guidance for solving job related problems	<input type="radio"/>	<input type="radio"/>	<input type="radio"/>	<input type="radio"/>	<input type="radio"/>
Extent to which my supervisor trusts me	<input type="radio"/>	<input type="radio"/>	<input type="radio"/>	<input type="radio"/>	<input type="radio"/>
Extent to which the amount of supervision given me is about right	<input type="radio"/>	<input type="radio"/>	<input type="radio"/>	<input type="radio"/>	<input type="radio"/>
Extent to which my supervisor is open to ideas	<input type="radio"/>	<input type="radio"/>	<input type="radio"/>	<input type="radio"/>	<input type="radio"/>
Extent to which the people in my organisation have great ability as communicators	<input type="radio"/>	<input type="radio"/>	<input type="radio"/>	<input type="radio"/>	<input type="radio"/>
Extent to which I receive, in time, the information needed to do my job	<input type="radio"/>	<input type="radio"/>	<input type="radio"/>	<input type="radio"/>	<input type="radio"/>
Extent to which conflicts are handled appropriately through proper communication channels	<input type="radio"/>	<input type="radio"/>	<input type="radio"/>	<input type="radio"/>	<input type="radio"/>
Extent to which the organisation's communication make me identify with or feel a vital part of it	<input type="radio"/>	<input type="radio"/>	<input type="radio"/>	<input type="radio"/>	<input type="radio"/>
Extent to which the organisation's communication motivates and stimulates an enthusiasm for meeting its goals	<input type="radio"/>	<input type="radio"/>	<input type="radio"/>	<input type="radio"/>	<input type="radio"/>
Extent to which horizontal (peers) communication with other organisational members is accurate and free flowing	<input type="radio"/>	<input type="radio"/>	<input type="radio"/>	<input type="radio"/>	<input type="radio"/>
Extent to which communication practices are adaptable to emergencies	<input type="radio"/>	<input type="radio"/>	<input type="radio"/>	<input type="radio"/>	<input type="radio"/>
Extent to which my work group is compatible	<input type="radio"/>	<input type="radio"/>	<input type="radio"/>	<input type="radio"/>	<input type="radio"/>
Extent to which informal communication is accurate and active (Informal communication refers to social relationships)	<input type="radio"/>	<input type="radio"/>	<input type="radio"/>	<input type="radio"/>	<input type="radio"/>
Extent to which the grapevine is active in	<input type="radio"/>	<input type="radio"/>	<input type="radio"/>	<input type="radio"/>	<input type="radio"/>



v4 04122014

EDITH COWAN

The impact of communication satisfaction on paediatric nurses job satisfaction and intention to stay



Government of **Western Australia**  
 Department of **Health**  
 Child and Adolescent Health Service

our organisation					
Extent to which written directives and reports are clear and concise	<input type="radio"/>	<input type="radio"/>	<input type="radio"/>	<input type="radio"/>	<input type="radio"/>
Extent to which the attitudes toward communication in the organisation are basically healthy	<input type="radio"/>	<input type="radio"/>	<input type="radio"/>	<input type="radio"/>	<input type="radio"/>
Extent to which our meetings are well organised	<input type="radio"/>	<input type="radio"/>	<input type="radio"/>	<input type="radio"/>	<input type="radio"/>
Extent to which the amount of communication in the organisation is about right	<input type="radio"/>	<input type="radio"/>	<input type="radio"/>	<input type="radio"/>	<input type="radio"/>
Extent to which the organisation's communications are interesting and helpful	<input type="radio"/>	<input type="radio"/>	<input type="radio"/>	<input type="radio"/>	<input type="radio"/>

If you are in middle management please finish the questionnaire here. If you are a ward nurse please continue to the end of the questionnaire.



v4 04122014

The impact of communication satisfaction on paediatric nurses job satisfaction and intention to stay



Government of **Western Australia**  
Department of **Health**  
Child and Adolescent Health Service

Q10 The following questions are related to various aspects of your job. Please indicate how satisfied or dissatisfied you are with each in your present job (Answer only if you are a ward nurse and are NOT in middle management).

	Very Dissatisfied	Dissatisfied	Neither satisfied nor dissatisfied	Satisfied	Very Satisfied
The physical conditions in which you work	<input type="radio"/>	<input type="radio"/>	<input type="radio"/>	<input type="radio"/>	<input type="radio"/>
Freedom to choose your own working methods	<input type="radio"/>	<input type="radio"/>	<input type="radio"/>	<input type="radio"/>	<input type="radio"/>
Your fellow workers	<input type="radio"/>	<input type="radio"/>	<input type="radio"/>	<input type="radio"/>	<input type="radio"/>
The recognition you get for good work	<input type="radio"/>	<input type="radio"/>	<input type="radio"/>	<input type="radio"/>	<input type="radio"/>
Your immediate manager	<input type="radio"/>	<input type="radio"/>	<input type="radio"/>	<input type="radio"/>	<input type="radio"/>
The amount of responsibility you are given	<input type="radio"/>	<input type="radio"/>	<input type="radio"/>	<input type="radio"/>	<input type="radio"/>
The rate of pay for nurses	<input type="radio"/>	<input type="radio"/>	<input type="radio"/>	<input type="radio"/>	<input type="radio"/>
The opportunity to use your abilities	<input type="radio"/>	<input type="radio"/>	<input type="radio"/>	<input type="radio"/>	<input type="radio"/>
Relations between management and staff	<input type="radio"/>	<input type="radio"/>	<input type="radio"/>	<input type="radio"/>	<input type="radio"/>
Future chance of promotion	<input type="radio"/>	<input type="radio"/>	<input type="radio"/>	<input type="radio"/>	<input type="radio"/>
The way the hospital is managed	<input type="radio"/>	<input type="radio"/>	<input type="radio"/>	<input type="radio"/>	<input type="radio"/>
The attention paid to your suggestions	<input type="radio"/>	<input type="radio"/>	<input type="radio"/>	<input type="radio"/>	<input type="radio"/>
The hours of work	<input type="radio"/>	<input type="radio"/>	<input type="radio"/>	<input type="radio"/>	<input type="radio"/>
The amount of variety in your job	<input type="radio"/>	<input type="radio"/>	<input type="radio"/>	<input type="radio"/>	<input type="radio"/>
Your security	<input type="radio"/>	<input type="radio"/>	<input type="radio"/>	<input type="radio"/>	<input type="radio"/>

Q11 Do you plan to leave your present nursing job (Answer only if you are a ward nurse and are NOT in middle management) ?

- Yes, within the next 6 months
- Yes, within the next year
- No plans within the year

Q12 Are you actively looking for another position in nursing (Answer only if you are a ward nurse and are NOT in middle management)?

- Yes
- No



v4 04122014

The impact of communication satisfaction  
on paediatric nurses job satisfaction and  
intention to stay



Government of **Western Australia**  
Department of **Health**  
Child and Adolescent Health Service

Q13 If you are/were looking for another job how easy or difficult do you think it would be for you to find an acceptable job in nursing (Answer only if you are a ward nurse and are NOT in middle management)?

- Very Difficult
- Difficult
- Easy
- Very Easy

For phase 2 of this research study the researcher will be conducting interviews and focus group discussions with participants. These interviews and focus group discussion will be confidential. If you are interested in discussing ways to improve communication satisfaction, job satisfaction and intention to stay and would like to be contacted please discuss this with the researcher on collection of the questionnaire or by email on [g.evans@ecu.edu.au](mailto:g.evans@ecu.edu.au) or by mobile phone on 0421255741. All email and phone conversations will be kept anonymous.

We appreciate you taking the time to fill in this questionnaire. Thank you for your participation.