



---

Dissertations

Theses and Dissertations

---

1986

## Mitotic Recombination and DNA Metabolismn in Saccharomyces Cerevisiae

Merl F. Hoekstra  
*Loyola University Chicago*

Follow this and additional works at: [https://ecommons.luc.edu/luc\\_diss](https://ecommons.luc.edu/luc_diss)

 Part of the [Medicine and Health Sciences Commons](#)

---

### Recommended Citation

Hoekstra, Merl F., "Mitotic Recombination and DNA Metabolismn in Saccharomyces Cerevisiae" (1986). *Dissertations*. 2401.

[https://ecommons.luc.edu/luc\\_diss/2401](https://ecommons.luc.edu/luc_diss/2401)

This Dissertation is brought to you for free and open access by the Theses and Dissertations at Loyola eCommons. It has been accepted for inclusion in Dissertations by an authorized administrator of Loyola eCommons. For more information, please contact [ecommons@luc.edu](mailto:ecommons@luc.edu).



This work is licensed under a [Creative Commons Attribution-Noncommercial-No Derivative Works 3.0 License](#).  
Copyright © 1986 Merl F. Hoekstra

MITOTIC RECOMBINATION AND DNA METABOLISM  
IN SACCHAROMYCES CEREVISIAE

by

Merl Francis Hoekstra

Library -- Loyola University Medical Center

A Dissertation Submitted to the Faculty of the Graduate  
School of Loyola University of Chicago in Partial  
Fulfillment of the Requirements for the Degree of  
Doctor of Philosophy

February

1986

TABLE OF CONTENTS

	Page
ACKNOWLEDGMENTS . . . . .	vi
VITA . . . . .	vii
LIST OF TABLES . . . . .	viii
LIST OF ILLUSTRATIONS . . . . .	x
Chapter	
I. GENERAL INTRODUCTION . . . . .	1
The diversity of genetic recombination . . . . .	4
An introduction to yeast recombination . . . . .	10
Properties of fungal recombination . . . . .	15
Mutations affecting yeast recombination . . . . .	20
Properties of mitotic recombination in yeast . . . . .	31
DNA repair mutations affecting mitotic recombination . . . . .	40
Introduction to experimentation . . . . .	56
II. RELATIONSHIPS BETWEEN A HYPER-REC MUTATION ( <u>reml</u> ) AND OTHER RECOMBINATION AND REPAIR GENES IN YEAST . . . . .	64
Introduction . . . . .	66
Materials and Methods . . . . .	71
Yeast Strains . . . . .	71
Media and techniques . . . . .	75
Isolation of <u>reml-2</u> . . . . .	75
Determination of mitotic recombination frequency . . . . .	77
Results . . . . .	79
The hyper-rec phenotype of <u>reml</u> does not depend upon the <u>SPO11</u> meiotic recombination function . . . . .	79
Interactions between the <u>reml-2</u> mutation and the <u>RAD50</u> and <u>RAD52</u> loci . . . . .	82
The <u>RAD6</u> gene is not required for the hyper-rec phenotype of <u>reml</u> . . . . .	85
The <u>reml</u> mutation does not reverse the meiotic defect of either <u>spoll-1</u> or <u>rad6-1</u> . . . . .	85
Discussion . . . . .	90

III.	HYPER-MUTATION CAUSED BY THE <u>rem1</u> MUTATION IN YEAST IS NOT DEPENDENT ON THE ERROR-PRONE OR EXCISION-REPAIR GROUPS . . . . .	96
	Abstract . . . . .	96
	Introduction . . . . .	98
	Materials and methods . . . . .	102
	Strains and growth conditions . . . . .	102
	UV and MMS treatment . . . . .	102
	Determination of spontaneous mutation rates . . . . .	105
	Results . . . . .	107
	The effect of the <u>rem1-2</u> allele on spontaneous mutation . . . . .	107
	Increased mutation in <u>rem1-2</u> strains is not dependent on error-prone or excision-repair groups . . . . .	107
	Radiation and chemical sensitivity of the <u>rem1-2</u> allele . . . . .	112
	Induced mutation in <u>rem1-2</u> strains . . . . .	116
	Discussion . . . . .	120
IV.	INTERACTIONS BETWEEN RECOMBINATION AND REPAIR FUNCTIONS DURING MITOSIS IN YEAST: GENETIC ANALYSIS AND CLONING OF <u>REM1</u> . . . . .	129
	Abstract . . . . .	129
	Introduction . . . . .	132
	Materials and Methods . . . . .	136
	Strains and culture conditions . . . . .	136
	Isolation of <u>RAD3</u> . . . . .	137
	DNA manipulations . . . . .	138
	Sucrose gradient analysis . . . . .	138
	Results . . . . .	140
	High levels of gene conversion in <u>rem1</u> cells requires excision-repair functions . . . . .	140
	Increased crossing-over in <u>rem1</u> cells occurs in the absence of excision-repair functions . . . . .	143
	Excision-repair mutations eliminate the need for recombination-repair functions in <u>rem1</u> mutant strains . . . . .	148
	The cloning of <u>REM1</u> . . . . .	158
	Discussion . . . . .	173

V.	PROPERTIES OF SPONTANEOUS MITOTIC RECOMBINATION OCCURRING IN THE PRESENCE OF THE <u>rad52-1</u> MUTATION OF <u>Saccharomyces cerevisiae</u> . . . . .	182
	Summary . . . . .	182
	Introduction . . . . .	183
	Materials and Methods . . . . .	186
	Strains . . . . .	186
	Media . . . . .	186
	Isolation of <u>lys2</u> mutations . . . . .	189
	Determination of mitotic recombination levels . . . . .	191
	DNA blot analysis . . . . .	191
	Results . . . . .	192
	Prototroph production at hetero-allelic loci in <u>rad52-1</u> are not due to reversion . . . . .	192
	Isolation and characterization of <u>lys2</u> mutations . . . . .	195
	Spontaneous mitotic recombination at <u>LYS2</u> in <u>RAD52</u> and <u>rad52-1</u> backgrounds . . . . .	197
	Discussion . . . . .	212
VI.	EXPRESSION OF THE <u>Escherichia coli</u> <u>dam</u> GENE IN <u>Saccharomyces cerevisiae</u> : EFFECT OF <u>IN VIVO</u> ADENINE METHYLATION ON GENETIC RECOMBINATION AND MUTATION . . . . .	216
	Abstract . . . . .	216
	Introduction . . . . .	218
	Materials and methods . . . . .	221
	Strains and culture conditions. . . . .	221
	Construction of pMFH1 . . . . .	221
	Measurement of recombination and mutation frequency . . . . .	225
	Transformation, DNA purification, and hybridization analysis . . . . .	225
	Results . . . . .	227
	Expression of the <u>dam</u> gene in <u>S. cerevisiae</u> . . . . .	227
	Examination of a specific DNA sequence in the presence of <u>dam</u> . . . . .	235
	Effect of <u>dam</u> methylation on spontaneous mitotic recombination . . . . .	239
	Effect of <u>dam</u> methylation on meiotic recombination . . . . .	239
	Effect of <u>dam</u> methylation on mutation . . . . .	241
	Discussion . . . . .	244

	Page
VII. EXCISION-REPAIR FUNCTIONS IN YEAST RECOGNIZE AND REMOVE N-6-METHYLADENINE CREATED <u>IN VIVO</u> . . . . .	250
VIII. GENERAL DISCUSSION . . . . .	263
LITERATURE CITED . . . . .	294

## ACKNOWLEDGMENTS

I would like to thank Dr. R. E. Malone for his direction during the undertaking of this research. His uncompromising attitude towards science was a valuable lesson learned. I also thank Drs. T. Hashimoto, R. V. Miller, S. K. Farrand, and R. Elder for helpful comments.

I thank my parents for their encouragement and unspoken support while I was a student.

Kevin Jordan, Chuck Edwards, Maarten Ryder, and Charlie Krikorian, trusted and treasured friends, offered kind advice along the way and helped me to appreciate certain by-products of yeast metabolism.

Lastly, but most importantly, I thank my wife Denise for her infinite patience. Denise was always ready with a helping hand, a word of advice, or a compassionate ear. She understood the reasons for the long hours required to complete my research, and tolerated my time away without complaint.

## VITA

The author, Merl Francis Hoekstra, is the eldest son of Art and Roselea Hoekstra. He was born December 2, 1959 at Vernon, British Columbia, Canada.

His elementary education was obtained in St. James and West Vernon Elementary Schools. His secondary education was completed in 1977 at VSSS, Vernon, B. C.

Mr. Hoekstra received a Rotary Scholarship to attend the University of British Columbia and graduated with a B.Sc. (Microbiology) in 1981. Following graduation, Mr. Hoekstra married Denise Maxine Denham on July 25, 1981.

In August, 1981, Mr. Hoekstra entered the Department of Microbiology at Loyola University of Chicago. During his study at Loyola University, he has received a University Basic Science Fellowship and a Schmidt Dissertation Fellowship. Mr. Hoekstra has been the recipient of two travel fellowships from the International Yeast Committee to attend conferences in France and Scotland. Also, in the spring of 1983, he won first place honors at the Sigma Xi Student Research Competition and the Illinois Society for Microbiology Graduate Student Research Competition.



LIST OF TABLES

TABLE	PAGE
1. Properties of Mutations used to Study <u>reml</u> . . .	69
2. Genotype of Strains . . . . .	72
3. Analysis of <u>reml-2/REM1 SPO11/spo11-1</u> Diploids .	80
4. Spontaneous Mitotic Recombination Frequencies in <u>spo11</u> and <u>reml</u> Diploids . . . . .	81
5. Analysis of <u>reml/REM1 RAD52/rad52</u> Diploids . . .	83
6. Analysis of <u>reml-2/REM1 RAD50/rad50</u> Diploids . .	84
7. Analysis of <u>reml-2/REM1 RAD6/rad6-1</u> Diploids . .	86
8. Spontaneous Mitotic Recombination in <u>reml rad6</u> Double Mutants . . . . .	87
9. Sporulation of <u>reml spo11</u> and <u>reml rad6</u> Double Mutants . . . . .	89
10. Strains . . . . .	103
11. Frequency of Spontaneous Mutation in Haploid Strains . . . . .	108
12. Mutation Rates in Haploid Strains . . . . .	109
13. Reversion Rates in Various Strains . . . . .	111
14. Reversion Frequency at <u>leu1-c</u> in Diploid Strains . . . . .	113
15. Phenotypes of Mutations used in Combination with <u>reml</u> . . . . .	134
16. Analysis of Various <u>reml/REM1 RAD/rad</u> Diploids .	141
17. Spontaneous Mitotic Recombination in Excision-Repair Deficient <u>reml</u> -containing Strains . . . . .	142
18. Chromosome Loss in <u>reml</u> -containing Strains . . .	147
19. Excision-Repair Mutations Rescue Double Mutant Inviability of <u>reml rad52</u> and <u>reml rad50</u> Double Mutants . . . . .	149

	Page
20. Spontaneous Mitotic Recombination in Triple Mutant Strains . . . . .	150
21. The <u>rem1</u> Mutations are Tightly Linked to <u>RAD3</u> . . . . .	159
22. Cloned Fragments that Complement for <u>RAD3</u> UV Sensitivity Reduce <u>rem1</u> Hyper-recombination . . . . .	167
23. Cloned <u>REM1</u> Complements for Double Mutant Inviability . . . . .	169
24. Strain Genotypes . . . . .	187
25. Frequency of Reversion to Prototrophy . . . . .	209
26. List of Strains . . . . .	222
27. Effect of <u>in vivo</u> Adenine Methylation on Mitotic Recombination . . . . .	240
28. Effect of <u>in vivo</u> Adenine Methylation on Meiotic Recombination . . . . .	242
29. Effect of <u>in vivo</u> Adenine Methylation on Mutation . . . . .	243
30. Segregation Analysis for <u>dam/---</u> <u>RAD/rad</u> Diploids . . . . .	257
31. Comparison of Mitotic Recombination in Diploid Strains Containing <u>rem1-2</u> and <u>rad3-2</u> . . . . .	282
32. Double Mutants Containing <u>rad3-2</u> and <u>rad52-1</u> are Viable . . . . .	283

## LIST OF FIGURES

Figure	Page
1. Illustration of Stern's Observation of Mitotic Recombination in <u>Drosophila melanogaster</u> . . . . .	7
2. Example of Chromosomal Configuration used for Determining Mitotic Recombination . . . . .	11
3. Simplified Version of the Two-Strand Model for Yeast Recombination . . . . .	37
4. Demonstration of the Concept of how to Determine if a Cloned Gene is Essential . . . . .	48
5. How to Follow Segregation of <u>rem1-2</u> . . . . .	57
6. Survival Curves for <u>rem1</u> -containing strains . . . . .	114
7. Relative Forward Mutation Levels in <u>rem1</u> Strains Following MMS Treatment . . . . .	117
8. Channelling Model as Applied to <u>rem1</u> . . . . .	121
9. Modified Channelling Model for the Action of <u>rem1</u> . . . . .	124
10. Chromosomal Configuration for Determining Chromosome Loss . . . . .	145
11. Sucrose Gradient Analysis of <u>rem1</u> Cells . . . . .	153
12. Neutral Sucrose Gradient Analysis of <u>rem1</u> Cells . . . . .	156
13. Map of pMFH100 and Demonstration that the Clone Co-segregates with UV <sup>R</sup> . . . . .	161
14. Survival Curves for <u>rad3-2</u> Strains Containing Various <u>RAD3</u> Clones . . . . .	163
15. Demonstration that pMFH100 Complements for <u>rem1</u> Hyper-recombination . . . . .	165
16. The <u>rem1</u> -complementing Plasmid Hybridizes with a Verified <u>RAD3</u> Internal Fragment . . . . .	171
17. Model for Interactions Between <u>rem1</u> and Various Repair Mutations Leading to the Production of Gene Conversion, Crossing-over, and Mutation . . . . .	176

	Page
18. Recombination and Mutation Frequencies at Various Loci in <u>RAD52</u> and <u>rad52-1</u> strains . . .	193
19. Southern Analysis of <u>lys2</u> Mutations . . . . .	198
20. Spontaneous Mitotic Recombination at <u>LYS2</u> in <u>RAD52</u> Strains . . . . .	200
21. Spontaneous Mitotic Recombination at <u>Lys2</u> in <u>rad52-1</u> Strains . . . . .	203
22. Relative Recombination at <u>LYS2</u> . . . . .	206
23. Allele Order of <u>LYS2</u> Mutations . . . . .	210
24. Construction of pMFH1 . . . . .	223
25. Illustration that Yeast DNA from <u>dam</u> (pMFH1) Transformants is Refractory to Cleavage by <u>MboI</u> . . . . .	228
26. Illustration that Methylated and Nonmethylated yeast DNA is Suseptible to <u>Sau3AI</u> digestion . . . . .	230
27. Evidence that <u>dam</u> -transformed Yeast Cells are Susceptible to <u>DpnI</u> Cleavage . . . . .	233
28. Restriction Map of <u>TRP1</u> 1.4 Kb <u>EcoRI</u> Fragment .	236
29. Construction of YIpDAM . . . . .	252
30. Analysis of <u>dam</u> -produced Methylation in Repair-deficient Mutants . . . . .	255
31. Segregation Analysis of <u>dam</u> -methylation in Tetra-type Tetrads for <u>dam</u> and <u>rad1</u> or <u>rad3</u> strains . . . . .	259
32. Relative Recombination Levels Along Chromosome VII . . . . .	265
33. Doubling Times in Various <u>rem1</u> and <u>rad</u> -containing Strains . . . . .	275
34. The <u>rem1-2</u> Mutation is Dominant to <u>rad3-2</u> for UV Sensitivity . . . . .	285
35. Schematic Diagram of Structure - Function Attributes for <u>RAD3</u> . . . . .	289

## CHAPTER I

### GENERAL INTRODUCTION

The three R's of deoxyribonucleic acid (DNA) metabolism are replication, recombination and repair. The processes are intimately associated and cellular functions can be implicated in an overlapping fashion for all three systems. For example, damage can arise in the form of base mispairing during DNA synthesis. If unrecognized or not corrected, the mismatch can become a mutation after a further round of replication. It has been estimated, however, that DNA repair mechanisms can increase the maintenance of post-replicative genetic stability by as much as three orders of magnitude (reviewed in 67). In the same vein, current models of genetic recombination all involve some amounts of DNA synthesis for the event to occur (50, 107,156,239). Different modes of DNA repair also implicate DNA synthesis as a requirement for the damage to be processed (67,90,96). The specific purpose of this dissertation is to gain further understanding of mitotic recombination. However, because of the intimate associations between replication, recombination and repair, experiments will be described that touch on all three of these cellular processes. An examination of mutations affecting genetic

recombination will be presented and an in depth analysis of the REM1 gene will be discussed.

The organism chosen as a model system for studying eukaryotic DNA metabolism is the baker's and brewer's yeast, Saccharomyces cerevisiae. The microbe is amenable to experimentation because it is easily manipulated. This ascomycete has some of the favorable attributes of prokaryotes. It is unicellular, small ( $\sim 5 \mu\text{m}$ ), easily grown in broth, and forms single colonies on solidified medium. The organism is a true eukaryote, however, with 17 linear chromosomes (164) containing centromeres (32) and telomeres (238). It has a nuclear membrane and contains mitochondria and other subcellular organelles such as golgi apparatus and endoplasmic reticulum (yeast subcellular structures are discussed in detail in references 20 and 222). The yeast also has a rich history of genetics dating back as far as the classic studies of Winge and Lindgren in the 1940's (136, 259) demonstrating Mendelian segregation.

The small size and ease of growth make S. cerevisiae amenable to laboratory analysis. However, with the onset of transformation studies (100), the yeast has become a favorite organism for molecular biological research. It can be said that S. cerevisiae is the Escherichia coli of eukaryotes.

Another major attribute for yeast is that it is non-infectious. There have only been a few documented cases of

saccharomycosis (43), and patients generally demonstrate other underlying problems (one patient was a self-stated "health food freak", raising the possibility of being in contact with, or ingesting, unusually large numbers of organisms). Like higher eukaryotes, the yeast has two mating types ( $\underline{a}$  and  $\alpha$ ) and is capable of mating, during which opposite mating types fuse to form a diploid organism (136). However, yeast stocks can also be maintained as haploids when they contain a mutation in the HO gene (heterothallic strains). Diploids, when starved for carbon and nitrogen, can undergo meiosis and form a tetrad of spores contained within an ascus (52). By micromanipulation, the meiotic products (ascospores) can be separated and allowed to germinate for genetic analysis.

Even considering this formidable list of attributes, it is not surprising that there are some problems in working with yeast. For example, it is difficult to specifically radiolabel chromosomal DNA. Yeast lacks a thymidine kinase (86). However, by using a tup mutation (which allows TMP uptake) in combination with tmp (deficient in thymidylate synthetase), thymidine monophosphate can be efficiently incorporated (11). Also, because of the small chromosome size [ranging from 150 to 2500 kilobase pairs (55), with an average size of 800 Kbp (177)] cytogenetic analysis has been hampered. However, the small size has afforded the isolation and analysis of intact chromosomes (22), and a number

of research groups are attempting to clone entire chromosomes.

### The Diversity of Genetic Recombination

Genetic recombination is a process that has been described in almost all organisms which have been directly examined for this process. Recombination has been described in organisms that span the phylogenetic spectrum. It has been extensively characterized in a large number of bacteria including both gram positive and negative species (reviewed in 256 and 258). Also many phages, infecting a wide range of bacteria, show genetic recombination (256,258). Recombination has been demonstrated in eukaryotic cells as well. It occurs in fungi such as Saccharomyces (63, 96,128) Schizosaccharomyces (134,240), Neurospora (25,76, 158), Aspergillus (179,180), Candida (253), Sordaria (255), Ascobolus (211), and Dictyostelium (113). Recombination has also been examined in insects such as Drosophila, mosquito, and housefly (23,256) and has been described in plants ranging from Maize to Lilium (108). Higher eukaryotes (mammalian cells) have been examined for the ability to perform recombination and tissue culture cells can be shown to perform homologous and non-homologous recombination (37, 66,135,226). Viruses that infect mammalian cells also show the ability to carry out recombination. This includes the recent demonstration of recombination in RNA viruses [Aphthovirus serotype 0 (116)]. In addition to the ubiquity



of genetic recombination across the phylogenetic spectrum, recombination has been implicated as a cellular mechanism for genome variation. Not only is genetic recombination a prime director for species diversity, it is involved in events including phase variation in Salmonella flagellar switching (264), somatic rearrangements for immunoglobulin class switching (153), antigenic variation in Trypanosomes (14), and pilus variation in Neisseria gonorrhoea (89). Mitochondrial DNA has also been shown to undergo recombination (234,265). Therefore, in part owing to its ubiquity, genetic recombination has a wide spread and diverse body of literature that predates the primary structure of DNA.

Recombination plays an active role in cellular metabolism. Without recombination, chromosomal non-disjunction and cellular inviability would occur in many organisms following the meiosis I reductional division (6). There are, however, exceptions to this rule. For example, male Drosophila generally do not show meiotic recombination events, although recombination can be induced by treatments like X-rays (174). The male fly is heterogametic, lacking synaptonemal complex and crossing-overs, and uses distributive pairing in meiosis (reviewed 245). However, male Drosophila are capable of carrying out recombination as evidenced by its discovery during P element transposition (44,214). In addition to its role in meiosis, recombination can occur during mitosis (at spontaneous frequencies approxi-

mately  $10^3$  fold lower than meiosis). Interest in mechanisms of mitotic recombination has been stimulated, in part, by the observation that mutagenic carcinogens are also recombinogens (96).

The study of mitotic recombination commenced in the 1930's with the observation of "twin spots" on the abdomen of Drosophila (233). Using specially constructed strains heterozygous, in repulsion, for yellow body (y) and singed wing (sn), Stern observed adjacent homozygous pools of y and sn cells immersed in a sea of heterozygous cells (Figure 1). These homozygous twin spots occurred at a low frequency and were attributed to a mitotic cross-over homozygosing the markers at some period during the fly's development, presumably after fertilization but before reaching maturity.

A similar approach can be taken in S. cerevisiae to demonstrate mitotic recombination (see Figure 10, Chapter 2). Strains that contain an ade2 mutation (a defect in phosphoribosylaminoimidazole carboxylase) accumulate a red pigment (112). Double mutants that contain adenine metabolism mutations epistatic to ade2, such as ade5, are blocked in red pigment formation and are white (112,207). Using red diploids homozygous for ade2 and heterozygous for ade5, half red/half white colonies can be observed (45,79). Each portion of the colony can be shown to be homozygous for wild type and mutant ADE5 alleles respectively, thus demonstrating a sectored colony approach to mitotic recombination

Figure 1 Illustration of Stern's observation of mitotic recombination in Drosophila melanogaster. A doubly heterozygous fly for the linked body color and bristle morphology genes (233) is wild type. If a somatic recombination event occurs, within the wild type cells one finds "twin spots" of homozygous yellow body color or singed bristle.

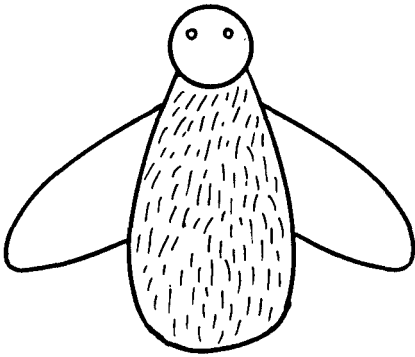

Brown body , Normal bristles

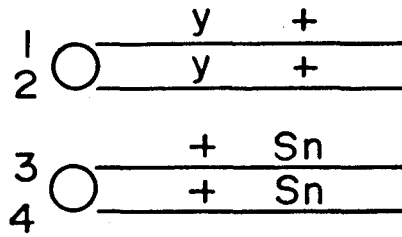

Holliday Structure  
Formation

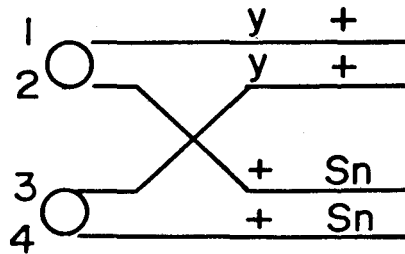

Resolution and  
Segregation

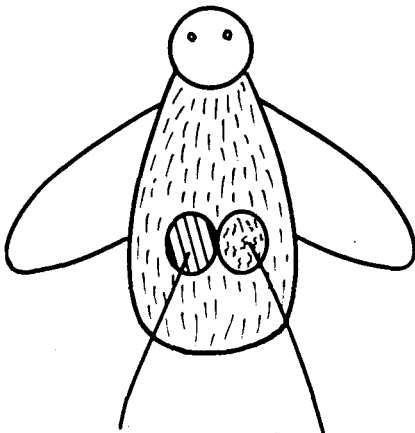
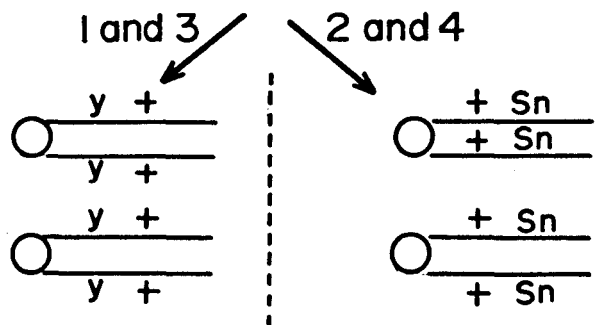

Yellow body Singed bristle

" twin spots "

in yeast (81,208). (Other mechanisms, including chromosome loss, can account for sectors and these will be discussed later.)

Twin spots have also been observed in the black population. Reciprocal mirror-image spots of varying pigmentation hue on the backs of patients with Bloom's Syndrome, a hereditary DNA repair defect (67), have been attributed to mitotic crossing-over. Cultured lymphocytes from these patients also have increased levels of sister-chromatid exchanges and quadriradials, which are thought to be diagnostic of mitotic recombination events.

Mitotic recombination has also been proposed as a chromosomal mechanism for the generation of familiarly based, bilateral, retinoblastoma (26). Using heterochromatin staining, isozyme analysis, and DNA blot analysis of restriction fragment length polymorphisms, it has been shown that a single somatic cross-over, homozygosing the chromosome 13 rb-1 mutation in heterozygous carriers, can generate a bilateral eye tumor "twin spot". A similar analysis has demonstrated that Wilm's disease can occur in heterozygous carriers after a somatic cross-over (114). Thus, from the original observation in Drosophila of somatic crossing-over, to the many studies in yeast, mitotic recombination is appearing in clinical literature as a mechanism for generating homozygosity to allow the expression of deleterious functions.

## An Introduction to Yeast Recombination

Recombination can occur in diploid yeast cells, as previously stated, during mitotic growth or during meiosis and sporulation. Meiotic levels of recombination (which are 3 - 4 orders of magnitude higher than mitotic levels) can be induced without the commitment to a reductional division (227). Cells that have been induced for meiotic recombination but returned to mitotic growth have been referred to as "meiototic" (50).

The recombination that occurs during mitosis and meiosis is spontaneous and occurs inter- and intragenically. In common yeast recombination terminology, intergenic recombination is referred to as reciprocal recombination or crossing-over and intragenic recombination as non-reciprocal recombination or gene conversion (50). The use of jargon to describe the type of recombination event, like the use of non-disjunction or chromosome-loss for segregation abnormalities, unconsciously implies a direct molecular mechanism. However, Roman has shown that greater than 90% of intragenic recombination is gene conversion (209).

While the mechanism of genetic recombination may vary for the different life cycle stages (50,63,239), procedures for detecting the rates are similar. As shown in Figure 2, intragenic recombination is most conveniently measured in diploids containing non-complementing alleles for mutations conferring auxotrophy (heteroalleles). Rare prototrophic

Figure 2 Example of chromosomal configuration used for determining mitotic recombination. In this example, aux1 and aux2 are mutations conferring auxotrophy and drug<sup>R</sup> is a mutation for drug-resistance. Heteroalleles are represented by aux1-1/aux1-2 and heterozygosity is represented by drug<sup>R</sup>/DRUG<sup>S</sup> and aux2-1/AUX2. The strain is auxotrophic for AUX1, drug-sensitive, and prototrophic for AUX2. If selection for AUX1 is placed on a culture, intragenic recombination (gene conversion) can be selected as shown in the left-hand portion. Approximately 50% of the time, distal markers will be crossed-over. In this specific case, aux1-1 is converted to AUX1. If one selects for drug-resistance, intergenic recombinants can be detected. In this case a simplified cross-over is depicted between AUX1 and DRUG. Demonstration that crossing-over has occurred is shown by aux2-1 being homozygous.

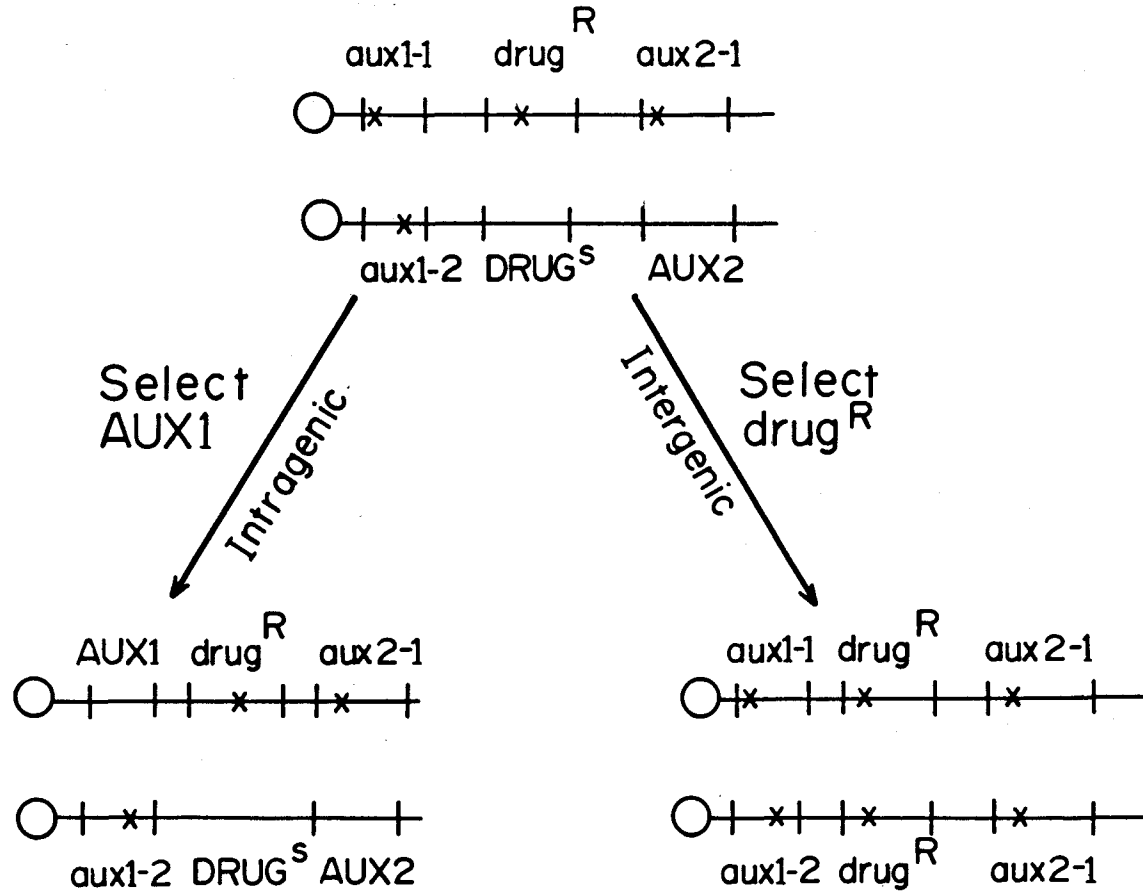



recombinants can be selected on synthetic complete medium by omitting the auxotrophic requirement. In a typical analysis, spontaneous intragenic mitotic recombinants can be detected at low frequencies, but in excess of reversion for either input allele (205). Upon shifting to a meiosis-inducing environment, the level of recombination increases and reaches a meiotic plateau by the time cells are committed to haploidization (52). The contribution of gene conversion and crossing-over to the intragenic exchange can be assessed by examining the genotypes of diploid recombinants at the heteroallelic locus. Non-reciprocal marker exchanges (gene conversions) are observed for greater than 95% of mitotic intragenic recombinants (Chapter 2 and reference 50).

Spontaneous intergenic recombination is conveniently measured with recessive drug-resistance alleles (Figure 2). Heterozygotes at a drug-resistance gene are sensitive. The level of drug-resistance is measured as an indication of recombination (50). It should be noted that multiple mechanisms can generate the resistant cell. A single cross-over between the centromere and the locus can homozygose the resistance allele, generating a selectable cell. Alternatively, gene conversion or loss of the chromosome with the sensitivity-conferring allele can produce a phenotypically resistant cell. Using appropriately constructed strains, the contribution of each mechanism can be determined (Figure 10, Chapter 2 and reference 142). The large majority of

drug-resistant colonies in wild type cells can be attributed to intergenic crossing-over (Chapter 2 and reference 142). Like intragenic recombination, the kinetics of intergenic recombination start with low levels in mitosis, increase following meiotic induction, and reach a maximum by the time cells are committed to haploidization (52). Depending upon the chromosomal distance over which a cross-over can take place (i.e., the distance from the centromere to a marker), intergenic recombination has a higher frequency than intragenic recombination (140,143).

Spontaneous mitotic and meiotic intragenic recombination occurs in a non-random association with crossing-over of markers flanking the locus of conversion (60,61,81,82, 210). This suggests, but in no way confirms, that gene conversion and crossing-over can have a common molecular precursor (50,63,64,239). Current models for mitotic and meiotic recombination generally accommodate this observation.

Despite the similarities in techniques for measuring mitotic and meiotic recombination, the mechanism generating a recombinant is not necessarily equivalent. Although many years of analysis have been dedicated to elucidating the mechanism of genetic recombination, the most satisfactory models are still controversial. It can be said that exact molecular mechanisms in fungi (particularly enzymology) are unknown. Any published model can account for most genetic data, but currently there is no unifying model for all fungi

nor for meiosis and mitosis. It is conceivable that no appropriate unifying model can be constructed and any proposed mechanism may require a caveat designating the model as specific for a given organism or period during an organism's life cycle. It is apparent, however, that meiotic and mitotic recombination have different properties. In the following pages, the properties of fungal recombination will be discussed.

### Properties of Fungal Recombination

Meiotic recombination has historically been studied by segregation pattern (or tetrad) analysis (162). Much of the work on segregation has been carried out in S. cerevisiae, however, other fungi such as Ascobolus (211) and Sordaria (255) have contributed to the knowledge of meiotic recombination. The primary advantages the latter fungi have over S. cerevisiae are: i) large numbers of asci can be scored directly by rapid visual analysis; and ii) eight spores are produced instead of four. The octads are due to a mitotic division occurring after meiosis but before spore formation (255). Thus, each spore contains genetic information from one of the eight DNA strands entering meiosis.

Segregation analysis requires the determination of the exact genotype for each spore. A diploid S. cerevisiae cell, heterozygous for a marker (M/m), will normally produce a Mendelian segregation pattern of 2M:2m. For octad-forming yeast the pattern is 4M:4m. If, following dissection and

germination, S. cerevisiae colonies are directly tested from the dissection plate rather than picking colonies to a master plate first, the previously described sectored colonies can be observed in meiotic segregants. This "plate dissection" method of segregant analysis functionally produces octad segregations of 4:4 from the tetrad pattern of 2:2 (63,64). Deviations from the 4:4 pattern occur as much as 20% of the time (63,64, R. E. Malone, personal communication). The deviations are two classes of aberrant segregations, gene conversion and post-meiotic segregation (PMS).

A meiotic gene conversion event, visualized by 6:2 (or 5:3) segregation, is non-reciprocal transfer of information from one chromatid to another. The information on one chromatid is lost and replaced with precise information from the corresponding chromatid. It should be emphasized that gene conversion is not mutation (60,61,207).

Formally, gene conversion is the transfer of information from two strands of one chromosome to another. In many models this transfer is presumed to occur by correction of mismatches in heteroduplex (or hybrid) DNA following strand transfer (155,232). Repair of a mismatch can result in gene conversion or restoration, depending upon which strand is repaired. Alternative models, such as Double-Strand Break repair (DSB), accommodate the formal transfer of two strands without necessarily requiring heteroduplex mismatch

repair (239).

The second class of non-reciprocal 4:4 patterns are post-meiotic segregations. These are visualized by 5:3 or 3:5 patterns (which in the strictest sense are also gene conversions) or by aberrant (non-reciprocal) 4:4's. Historically these are presumed to reflect the persistence of unrepaired mismatches in hybrid DNA following strand transfer (256). For 5:3 segregations only a single heteroduplex need be postulated, while aberrant 4:4's require two unrepaired heteroduplexes (171). The 5:3 type segregation is often called asymmetric because of its requirement for only a single heteroduplex (63). Aberrant 4:4 segregations, requiring two heteroduplexes, are termed symmetric (63). Fogel and co-workers have demonstrated that S. cerevisiae is capable of generating asymmetric heteroduplex DNA but the level of symmetric hybrid DNA is extremely low [essentially undetectable (63,64)]. This is in contrast to other organisms, notably Ascobolus, in which aberrant 4:4's are readily detected (211). It should be noted, however, that certain models of mitotic recombination for S. cerevisiae differ from models of meiotic recombinants in that extensive symmetric heteroduplex DNA is described (45,50).

An important observation pertinent to meiotic recombination is that stretches of DNA along the chromosome are converted and not single base pairs (171,258). In other words, adjacent sites are frequently involved in the same

conversion event (co-conversion). The frequency of co-conversion is a distance dependent property and can occur in meiosis for regions hundreds of nucleotides long. For example, DiCaprio and Hastings (38) have reported the co-conversion of four markers along a region of one centi-Morgan. It is believed that the length of the co-conversion tract reflects the length of a heteroduplex (50,171,258). If true, meiotic heteroduplexes are relatively short compared to mitotic co-conversion tracts (45,50,79,82), some of which have been described to essentially cover the length of a chromosome arm (discussed below). Golin and Falco (83), however, have recently argued that long mitotic heteroduplexes are produced by multiple recombination events occurring along the length of a chromosome arm.

As a consequence of co-conversion, frequencies of meiotic gene conversion reflect the allelic position within a gene (64,211). For genes with a number of alleles, frequencies tend to be greater at one end and decrease towards the other end (64,211). This has been termed polarity and is believed to be a property of an allele's position relative to a fixed recombination initiation site. A prevailing theory is that alleles closer to an initiation site will have a higher probability of being involved in a recombination event than alleles further away. With one notable exception, mitotic recombination events appear to initiate randomly (115), which leads to the absence of polarity. The

exception is the recently discovered region, HOT1 (115). In a screen for mitotic recombination hotspots, Keil and Roeder discovered this unique site which is part of the repeated ribosomal DNA gene cluster (115). One hypothesis to account for HOT1, and the lack of other mitotic hotspots, is that the generation and retention of repeated DNA families may require gene conversion (10,169,172). This mechanism has been hypothesized not only for yeast, but also proposed for the evolution of globin gene families in mice (41). It is interesting that fine structure sub-clone mapping has shown that HOT1 overlaps the transcription initiation region of the 21S ribosomal RNA gene (R. Keil, personal communication), suggesting that transcription of this region may be involved in the generation of the hotspot.

Although mitotic recombination apparently occurs without specific initiation sites, it is similar to meiotic recombination in showing a distance-dependent frequency (50). A number of groups have shown (Chapter 3 and references 63,148,149,230) that spontaneous and induced recombination can be used for fine structure mapping. Close heteroalleles within a given genetic distance will show a recombination frequency that depends on the genetic distance, presumably as a reflection of the probability of being jointly involved in a heteroduplex. The further apart two alleles are from each other, the more frequently a recombination event can occur between them.

An important property for gene conversion being integral to most recombination models is that it is not necessarily allele specific (171). In other words, for meiotic recombination, aberrant segregations should be a function of the position in the gene and not a function of the specific allele. Segregations in S. cerevisiae show that gene conversion to either allele at a given locus occurs with equal frequency (parity). Analysis of 30 sites in unselected tetrads, including base substitutions and frameshift mutations, shows that parity in conversion frequencies for 6:2's and 2:6's occurs (63,64). Large deletions also convert in both directions. Similar analyses for mitotic recombination have also shown parity. In heteroallelic crosses, convertants can be shown for either input allele at equal frequencies (50,79,81). Thus, in S. cerevisiae, both mitotic and meiotic recombination display parity.

#### Mutations Affecting Yeast Recombination

A classic approach to understanding metabolic and developmental processes is through mutational analysis. The logic being that in order to appreciate all the intricacies of a given process one should perturb the system at a specific point and examine the ramifications. A pertinent example is that of recA in E. coli. Mutation analyses have demonstrated not only recA's role in homologous recombination, but its vital role in the so-called "SOS" repair process (reviewed in 249). The sum of knowledge on recA is not



yet complete; however, mutational analysis preceded and allowed purification of the protein to elucidate exacting biochemical and biophysical details of its action (201,249).

In yeast, a number of approaches have been fruitful for the isolation of potential recombination-deficient strains. As in all mutant hunts, the nature of an isolated mutation is entirely dependent upon the rationale used to construct the assay system. Therefore a wide variety of recombination-defective mutations are known.

Four specific classes of meiotic recombination-deficient mutations have been described in S. cerevisiae (reviewed in 71). Some of these mutations confer altered mitotic recombination phenotypes. In the following pages, a discussion of recombination mutants and their phenotypes will be presented. A comparison will be made, where appropriate, between the effects of these mutations on meiotic and mitotic recombination.

Possibly the most effective approach to examining mutants defective in meiotic recombination has been to isolate mutations characterized as radiation or chemical sensitive and subsequently examine their affect on recombination. (This approach appears to be fruitful for all organisms in which it has been attempted.) A second approach is to isolate mutations affecting sporulation and examine the recombination phenotype (47,49). The inference from this approach is that recombination is an integral part of meiosis. Any

strain unable to sporulate is a potential candidate for containing a mutation defective in recombination (52). By mutagenizing homothallic spores and screening diploid survivors for the inability to sporulate, the temperature sensitive mutations spo7, 8, and 11 were isolated and shown to be deficient in meiotic recombination (49). Both spo7 and 8 have subsequently been shown to be defective in pre-meiotic DNA synthesis (52). The recombination phenotype may reflect this defect. The spoll-1 mutation confers a deficiency in meiotic gene conversion and intergenic recombination (17, 120,121,247). Strains containing spoll are proficient in mitotic recombination (16,17,143) and transcription of SPOLL is regulated during the S. cerevisiae life cycle [it is induced during meiosis (reported in 121,247)]. Dawes and Hardie modified this procedure by treating vegetative populations of homothallic diploids with chemicals known to be more effective mutagens (36). They allowed the culture to recover for a few generations in presporulation medium and subjected the cells to sporulation conditions. Recessive mutations affecting sporulation were recovered by treating the culture with ether to kill vegetative cells (and some ascospores), germinating the survivors, repeating sporulation conditions, and screening for the ability to form asci. Unfortunately, the mutations isolated have not been extensively characterized.

A third, and more brute-force, approach to isolating

meiotic recombination mutations has been to screen directly for mutations affecting intragenic gene conversion. Much work has been generated by Fogel and co-workers using this approach. Using a heteroallelically-marked chromosome III disome, Roth and Fogel (213) isolated con1, con2, and con3 (deficient in meiotic gene conversion). These, unfortunately, are also poorly characterized but have been shown proficient in premeiotic DNA synthesis (213). These same workers have also isolated mei1, mei2, and mei3 by use of the disome approach (213).

A chromosome VII disome has been used by Fogel's group to isolate recessive mutations blocked for induced mitotic gene conversion. The rec1-4 series was isolated by this approach. Amongst these, rec2 and rec3 reduce sporulation while rec4 affects gene conversion at arg4 (205).

Finally, Williamson and Fogel have isolated four recessive mutations (cor1 - cor4) presumed to be defective in heteroduplex mismatch correction (63,254). Strains with these mutations demonstrate an increase in the ratio of 5:3/6:2. Subsequently the cor series has been renamed pms (altered post meiotic segregation) to avoid the direct implication of a speculated mechanism (254).

As mentioned earlier, many of the mutations initially isolated as sensitive to radiation (RAD) have been characterized with respect to genetic recombination. In general, it appears that mutations conferring sensitivity to ionizing

radiation affect sporulation (and spore viability), while UV-sensitive mutants are proficient in meiotic recombination and sporulation [refer to Table 1 in Haynes and Kunz (96)]. To summarize, by convention, RAD series numbers up to 49 have been reserved for UV sensitive mutations and RAD numbers starting at 50 are designated for X-ray sensitive mutations (71). There is considerable overlap in sensitivity between the two types of radiation-sensitive series and mutations that affect recombination-repair of UV light-induced DNA damage are in the RAD50 series even though the most striking phenotype is X-ray sensitivity (71,96). In addition, there are X-ray sensitive mutations that are also UV sensitive (71,96). These mutations (e.g. rad6 and 18) block X-ray and UV mutagenesis and have been proposed to block the error-prone UV-repair pathway (note that the use of error-prone in this context is not meant to imply inducibility as compared to the E. coli error-prone repair system). It is interesting that rad6 and rad18-containing strains are not induced for mitotic recombination after X-rays (71,184), suggesting that a common error-prone repair pathway exists for UV and X-ray damage not involving recombinational mechanisms.

The best characterized group of X-ray sensitive mutants is the so called RAD50 recombination-repair epistasis group (71,96) (A discussion of epistatic interactions is presented below.) As mentioned, the rad mutations

conferring a defect in meiosis have the common property of X-ray sensitivity. It is tempting to propose that this correlation may occur because X-ray resistance and meiotic DNA metabolism both require functional recombinational machinery. In many organisms, X-ray repair processes appear to operate via a recombinational mechanism (30,102,154) (hence, for yeast, the term "RAD50 double-strand break repair group" is synonymous with "RAD50 recombination-repair epistasis group"). Since double-strand breaks are lethal to strains lacking recombination-repair functions [Ho and Mortimer have demonstrated this in rad52-1 strains (102)] and DNA strands must be broken during meiotic recombination, this may account for the common gene product requirement.

Meiotic recombination can mechanistically occur by single-strand breaks (156), while double-strand break repair has been shown to be defective in X-ray sensitive mutants such as rad52-1 (101,102,198). It may be that strand breaks remain unrepaired if the overall recombination process is defective in rad52. Resnick *et al.* have shown that single-strand interruptions (SSI's) accumulate in rad52 strains during meiosis (197). These SSI's do not accumulate in wild-type cells and are dependent on DNA synthesis (hydroxyurea blocks their occurrence). Potentially these SSI's represent strand breaks involved in the initiation of meiotic recombinations.

Recently, Resnick and Nitiss have extended the

observation of SSI's in meiotic recombination. Using a relatively synchronously sporulating strain and a complex sucrose gradient system to enrich for certain regions of genomic DNA, these workers can demonstrate SSI's reproducibly accumulating at specific chromosomal domains (195, 200, J. Nitiss, personal communication). This may be the in vitro observation of recombination initiation sites.

While rad52 has been one of the most extensively characterized X-ray sensitive mutations in terms of its DNA profile on sucrose gradients at time points during meiosis, this mutation and other ionizing-radiation sensitive rad mutations have been characterized using other techniques. Analyses involving interrupted meiosis [return to mitotic growth (52)] and the spol3 reductional division bypass (described below and in reference 52) have demonstrated the recombination-deficient phenotype of some rad mutations (71, 141). Also, the spol3 procedure (141), has allowed the analysis of epistatic interactions between recombination defective mutations (52,71,141).

As mentioned previously, meiotic recombination can be measured by interrupting the meiotic process and plating cells on vegetative medium. A number of groups have used this approach to determine if sporulation-defective rad mutants are deficient in meiotic recombination and, at what stage (premeiotic DNA synthesis, early meiosis, or haploidization) the sporulation defect becomes apparent. A number

of rad mutations have been examined this way. Game et al. (73,74) have examined rad6-1, rad50-1, rad52-2, and rad57-1 mutations. Prakash et al. (186) have described rad6 and rad52 and Malone has extensively characterized rad50 (140). Game and co-workers found that strains with rad6-1 underwent premeiotic DNA synthesis but failed to progress past this point (74). In this study, recombinants were not found among cells removed from sporulation medium, but no decline in viability was observed at times that meiosis would be complete in wild type cells. The rad6-1-containing strains do not, however, form viable spores (Chapter 2 and reference 74) and may not commit to meiotic recombination. Whether this reflects an actual involvement in meiotic recombination is controversial (139,142).

RAD6 has been cloned (183) and a recent report has described the predicted amino acid sequence (201). The gene product is unusual as it demonstrates a high degree of charged amino acids and is similar in size and structure to the high mobility group (HMG) of DNA binding proteins in mammalian cells. The function of this group of proteins is currently unknown, but they have been proposed to be structural regulatory proteins. This in no way gives a function to the RAD6 gene product, but speculation based on structural homology can easily generate a role for the protein in DNA metabolism at virtually any stage of meiosis.

The other rad mutations studied by Game et al. (74)

sporulate (at a reduced level), and the spores formed are inviable. Return to mitotic growth (RTG) experiments have shown rad50 and rad52-containing mutants to have reduced levels of intragenic and intergenic recombinants (74,139, 187). These strains do show premeiotic DNA synthesis (74). The cells also show a drop in viability early in meiosis (74,186). These findings suggest that rad50 and rad52 strains are defective in meiotic recombination and that the observed lethality is a consequence of initiated or committed recombination that remains unresolved.

The rad57-1 mutation has also been examined by RTG procedures (71,73). This mutation differs from rad50 and rad52 in that some recombinants are observed early in meiosis. The frequency does decline later in meiosis, indicating the time of action for the RAD57 gene product is different from the products of RAD50 and RAD52. The lethality observed in the latter strains at the completion of meiosis is also found in rad57. A similar burst of recombinants has also been demonstrated in homozygous rad51-3 diploids (161). Thus, by interrupting meiosis and returning cells to mitotic conditions, strains sensitive to ionizing radiation can be demonstrated to be largely deficient in recombination.

Return to mitotic growth experiments have a number of flaws inherent in their design. For example, even in the most synchronous strains of S. cerevisiae, meiotic events



occur over a period, rather than a point, of time (52). Therefore, rare events, even when selected, can be masked by asynchrony. Also, the act of removing cells from meiotic conditions to mitosis produces cells that are at a stage between both life stages. These cells are neither mitotic nor meiotic.

Malone and Esposito used an alternative approach to investigating putative  $\text{Rec}^-$  mutations (141). In 1980, Klapholz and Esposito described two recessive mutations from an ATCC strain, spol2-1 and spol3-1, that confer the ability upon strains carrying these mutations to undergo premeiotic DNA synthesis, meiotic recombination, and sporulation without meiotic division (117,118). In other words, these strains form dyad asci by bypassing reductional division but maintaining a normal meiosis II centromeric-disjunctive equational division. Thus meiotic recombination can be assayed without haploidization, and the meiotic process is allowed to reach completion, unlike RTG experiments.

Recombination is believed to be required during meiosis for homologous chromosome pairing prior to centromere disjunction (6). Therefore, a logical explanation for the lethality conferred by a rad mutation during meiosis is an inability to segregate chromosomes properly in meiosis I. Using this reasoning, Malone examined meiosis in spol3 homozygous diploids containing rad50 and rad52 (139). He demonstrated that spol3 "rescued" rad50 and allowed viable

diploid spore formation. The sporulation occurred without recombination, confirming that rad50 is defective in meiotic recombination and supporting the notion that meiosis I division depends on recombination. The spo13 mutation did not "rescue" rad52. Inviabile dyads were formed from the double mutant. However, triple mutants of spo13-1 rad50-1 rad52-1 were viable, leading to the interpretation that RAD50 and RAD52 act sequentially in meiosis with RAD50 epistatic to RAD52. If rad50 blocks the formation of a recombination intermediate that requires RAD52 for repair or resolution, spo13 rad52 stocks can survive meiosis if they contain rad50.

Similarly, rad51-3 and rad57-1 have been reported to resemble rad52-1 in that spo13 does not rescue meiotic lethality (71). Triple mutants of spo13 rad50-1 rad57-1 are viable and show no recombination, implying that rad57 lethality is due to a defect in recombination. The spoll mutation has also been examined in the spo13 bypass system (141). Double mutants of spo13 spoll produce dyad spores but no recombinants. Epistasis was demonstrated in this analysis, with spoll acting before rad52. The bypass has also been attempted with rad6, but the spo13 rad6 double mutant, which forms inviable dyads, is not "rescued" by other rad mutations (141). Using this approach, a recombination pathway has been described for the interactions of spo and rad mutants through meiosis. Both rad50 and spoll act

before rad52, and rad50 acts before rad57 (52,71,139,141).

The concept of using known mutant phenotypes, in double mutant strains, to analyze a less characterized mutation has been exploited for this dissertation. Interactions between mutations during mitosis will be described later in this introduction. The reason for using a specific mutation is described when the mutation first appears.

### Properties of Mitotic Recombination in Yeast

Interest in mitotic recombination has been stimulated, in part, by the observation that genotoxic agents increase the rate of mitotic gene conversion and crossing-over (51). The level of spontaneous mitotic recombination, as mentioned earlier, is three to four orders of magnitude lower than meiotic recombination. However, treatment of yeast cells with mutagenic regimens such as UV, X-rays, chemical agents, or thymidylate starvation induces the levels of mitotic recombination significantly above background (67,96,127). This observation has been used as the impetus to construct genetically marked S. cerevisiae strains for use as a eukaryotic model system in tests similar to the widely used Ames Salmonella mutagenicity test.

Studies of mitotic recombination induction lead to divergent interpretations, both of which may be correct. One interpretation suggests that recombination is induced by physical lesions present in the DNA (50,67,96). Alternatively, the induction of a state of competence for mitotic

recombination may be the explanation for the increase in rates (54). Fabre and Roman X-ray irradiated an  $\alpha$  strain of *S. cerevisiae* containing a double mutation in ade6 and mated this with an unirradiated a/a strain heteroallelic for ade6 and containing the kar1 mutation (to prevent nuclear fusion). They were able to demonstrate an induction of recombination in the unirradiated strain, suggesting the involvement an inducible, diffusible factor in the X-ray stimulation of mitotic recombination. Fogel and Hurst (58) also examined UV-induced recombination of genes on different chromosomes. They observed joint conversion frequencies much higher than expected from independent events and argued that UV-induction of mitotic recombination was due to a diffusible factor.

The induction of competence for spontaneous mitotic recombination may be a population phenomenon (62). When intergenic and/or intragenic recombinants are jointly selected, the frequency is often greater than that predicted from single selection for both (coincidence). A number of groups (62,97,109,157), have argued that the coincidence of recombination in Schizosaccharomyces pombe (157) and *S. cerevisiae* may be due to a recombinationally proficient sub-population of mitotic cells ["parameiosis" (62)]. This notion of coincidence remains a speculation and is not a generally accepted property of mitotic recombination. Demonstration of its presence will require the isolation of

the sub-population (a difficult experiment to design) or isolation of a mutation that predisposes cells to maintain the competent stage. Part of the problem in thinking of mitotic recombination in these terms appears to stem from attempts to generalize the results for UV and X-ray induction experiments to studies on spontaneous mitotic recombination (42). In the two cases, the lesion(s) and cell's response(s) are most likely different and caution must be advised for directly comparing data from these experiments.

The properties of spontaneous mitotic recombination can be compared to meiotic recombination. The most obvious difference in the two forms is the frequency. Meiotic recombination occurs  $10^3$ - $10^4$  fold more often than mitotic recombination for a given genetic region (50,128). Also, each recombination event in meiosis is an independent event while mitotic recombination events occur in a stochastic fashion; a measured recombinant may reflect an occurrence during a previous generation.

Meiotic recombination is believed to require initiation at specific sites (171). This is reflected in the previously described property known as polarity. Mitotic recombination is initiated randomly and occurs without polarity (50,171). Both forms of recombination do have a distance dependence. Mitotic co-conversion at both LEU1 and TRP5 (18 cM apart) is greater than LEU1 and MET13 (94 cM) (79). The distance dependence phenomenon, however, depends

upon the treatment given to cells. Spontaneous mitotic recombination shows distance dependent co-conversion. However, co-conversion following X-ray treatment is not observed, at least for telomere proximal markers on chromosome VII (209). Once again, caution is required in examining the properties of induced recombination when describing the rules of spontaneous mitotic recombination.

One of the more interesting comparisons between mitotic and meiotic recombination is in the nature of the postulated heteroduplex structure (in classical single-strand invasion models). During mitosis, recombinants at heteroalleles are reciprocally exchanged 12-14% of the time [70/553 selected prototrophs at various heteroalleles originating spontaneously or by mutagen induction (summarized from 51)]. Historically, from the work in Drosophila, all mitotic recombinants were believed to be cross-overs (233). However, these data eliminate reciprocal exchanges as the sole origin of intragenic recombinants. The high frequency of reciprocal exchange and the ability to recover with equal amounts of ++/++ cells and ++/m1-1 m1-2 cells from heteroalleles (+m1-1/m1-2+) (50,79) is not expected if the molecular mechanism for S. cerevisiae mitotic and meiotic recombination systems follow the same rule. As described, meiotic recombination in yeast lacks symmetric heteroduplex [it occurs at most in 0.008% of all segregations (63,64)]. The recovery of ++/++ and ++/m1-1 m1-2 at a relatively high

frequency from intragenic recombinants indicates that mitotic cells may form a symmetric Holliday structure not detected in yeast meiosis (5,50,79-82).

Meiotic intragenic recombination is associated with reciprocal exchanges 30-65% of the time (63,64), implying that the two processes are separate manifestations of the same event. Spontaneous mitotic intragenic recombination is non-randomly associated with reciprocal exchanges 10 to 55% of the time (50). This suggests that mitotic gene conversion, like its meiotic counterpart, may have a common precursor with crossing-over.

The timing of meiotic recombination is such that exchange events occur after premeiotic DNA synthesis, at the four strand stage (232,256). As proposed by Stern (233), it was generally accepted that mitotic recombination also occurs at a four strand stage either late in S period or during G2. Historically it was not obvious how reciprocal recombination between unreplicated homologs could generate sectorized colonies with cross-over configuration of markers distal to the exchange point. A number of workers have shown that, in *S. cerevisiae*, mitotic recombination can occur at the two strand stage as well as the four strand stage (53,54,79-82).

Undoubtedly one of the most elegant experiments used to argue for G1 recombination is described by Fabre (53). Using a diploid strain heteroallelic for cdc4 (which confers

a conditional-lethal cell-division-cycle arrest early in G1), Fabre was able to detect CDC4 recombinants at the permissive and non-permissive temperatures. This established that gene conversion can occur during the two-strand (G1) phase of the cell cycle.

Based on a large body of genetic data collected from the analysis of the genotypes of sectored prototrophic colonies, Esposito and co-workers (45,50,79-82) presented a molecular model for yeast mitotic recombination that invokes prereplicative two strand stage as the substrate for initiation of recombination. Their model is based on the Aviemore model (45,50,156) for general genetic recombination. Their model, as well as its genetic predictions, is compared with a four strand model in Figure 3. The figure is a simplification of the model for the sake of comparison. An excellent description of the salient points used in its construction is given in a review by Esposito and Wagstaff (50).

Using as an example a hypothetical heteroallelic configuration of m1-1+/+m1-2 for a given locus, G2 events produce sectored colonies with the markers at locus M being (m1-1+/++)/(++/+m1-2). Only G1 events can generate the other eight classes of sectored prototrophic marker segregations. Golin and Esposito found that 70/71 Trp<sup>+</sup> prototrophs at TRP5 and 20/20 Leu<sup>+</sup> prototrophs at LEU1 are produced by G1 conversions (81). Analysis of this sort leads to a molecular model proposing prereplicative strand exchange in G1



Figure 3 Simplified version of the two-strand model for yeast mitotic recombination. This figure has been simplified from Esposito and Wagstaff (49). The left-hand side demonstrates 2-strand exchange before replication. After resolution, 9 different combinations of markers are possible. 1 & 3/2 & 4 represent the chromosomes segregating into a given side of a sectorized colony. The right-hand side is the classical 4-strand model with exchange after replication. Only one class of markers is predicted in a given sectorized colony following resolution.

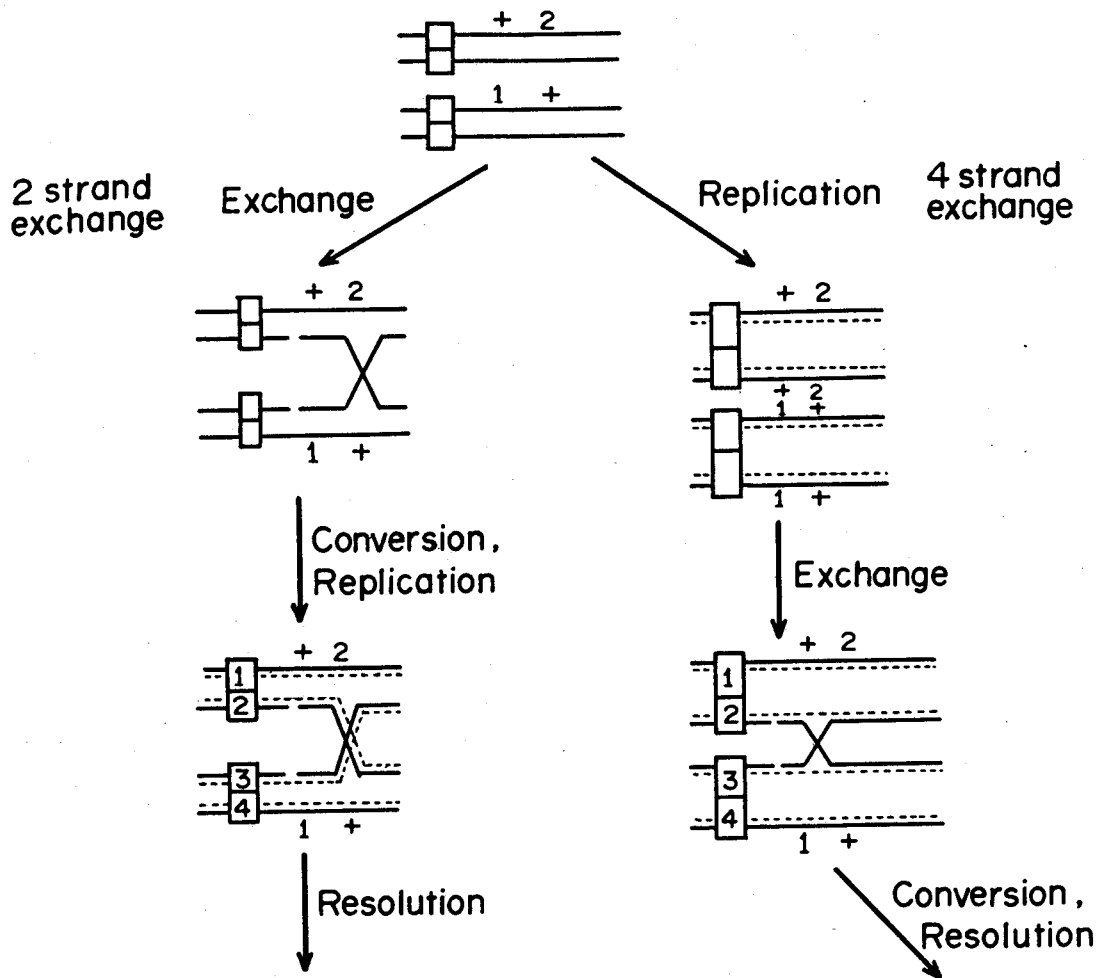

	I	II	III	IV	V	VI	VII	VIII	IX
1 and 3	++	++	++	++	++	++	++	++	++
	1+	+2	++	12	+2	1+	+2	1+	1+
2 and 4	++	++	++	++	++	++	++	++	++
	1+	+2	++	12	++	++	12	12	+2

+	+
1	+
-----	
+	+
+	2

or early S phase. The heteroduplex persists until conventional mismatch repair occurs. Subsequent DNA replication during S phase generates revertant prototrophs which show the diagnostic marker configuration described above. Golin and Esposito further noted that the nature of the spontaneous mitotic heteroduplex was symmetrical at least 30% of the time [for LEU1 and TRP5 (81)]. Therefore, the two strand model for mitotic recombination, as formally stated (45,50), can accommodate asymmetric and symmetric heteroduplexes equally well. DNA replication through the cross-over resolves the recombination event. This is in marked contrast to the rarity of symmetric heteroduplex during yeast meiosis and the post replicative timing of its occurrence.

The data by Fabre (52) and Golin and Esposito (80) in no way require all mitotic recombination to occur solely in G1. Roman and Fabre recently demonstrated that although most X-ray-induced revertants arose in G1, these events can also take place in G2 (209). By using the fungicide methylbenzimidazol-2-yl-carbamate [which affects microtubules (260, 261)], Roman and Fabre held cells in G2 arrest, treated the cells with X-rays to stimulate mitotic recombination, and found the G2-diagnostic class of revertants increased from 6% to 28% of all revertants. Thus, they demonstrated that yeast cells are competent to undergo G2 recombination. Once again, caution is required as Roman relies on X-rays to

stimulate the low levels of mitotic recombination. A direct correlation between his experiments and Esposito's analysis of spontaneous events may not be warranted.

Recombination is apparently essential to meiosis in yeast; an attempt at chromosomal alignment and reductional division without a complete complement of required gene products leads to lethality and, if formed, inviable spores. Mitotic recombination does not have the same constraint. Even the most recombinationally deficient strains (rad52) can survive mitotic growth. These same strains, however, are sensitive to certain DNA damaging (recombinogenic) treatments (73,140,186). It can be stated, therefore, that any observed mitotic recombination in yeast, be it spontaneous or induced, may be a reflection of DNA repair.

#### DNA Repair Mutations Affecting Mitotic Recombination

Studies of mutations conferring sensitivity to radiation and/or chemical mutagens have been informative in determining not only how a cell responds to environmental insults, but how gene products interact during growth. In this section, a description of the major RAD genes and a discussion of their presumed role in mitotic cellular metabolism will be described. Some of these mutations have been discussed in detail above with regards to their affects on meiotic recombination. These mutations will only be mentioned briefly below. As will become obvious, mutations in RAD genes have many phenotypes that include not only

sensitivity to radiation. As a generalization, many rad mutants are affected in mitotic recombination and/or mutation and thus are superb subjects for analyzing the processes.

The major RAD mutations of yeast have been classified into three broad groups, termed epistasis groups (71,96). The groups are named after a prototypic mutation for each class and have synonymous alternative names designating a proposed mechanism for DNA repair (244). The classes are: i) the RAD3 excision-repair epistasis group; ii) the RAD6 error-prone repair epistasis group; and iii) the RAD52 double-strand break or recombination-repair group.

The usual method of isolating radiation sensitive mutants is experimentally simple. Cells are treated with a mutagen and plated on rich medium. Surviving colonies are then tested for the ability to survive treatment by X-rays or UV-light by a replica plate assay. Cox and Parry deliberately tried to saturate the yeast genome in a search for rad mutants (33). They uncovered 96 isolates that were arranged into 22 complementation groups. Cox and Parry argued, based on the number of independent isolates for each complementation group, that statistically more loci must be involved in radiation damage repair in yeast. More recent speculations, following the cloned isolation of damage-inducible (din) genes, have raised the possibility that yeast, like E. coli, dedicates up to 1% of its genetic potential to

handling environmental insults (215).

Early work on the repair of DNA damage in yeast has relied primarily upon genetic studies. Biochemically, most DNA repair gene products are uncharacterized because of the earlier mentioned difficulties in specifically radiolabeling genomic DNA and an abundance of endogenous proteases (112) that make enzyme isolations difficult. Genetically, however, much is understood regarding the potential role(s) for a number of radiation-sensitive mutations. Many of the studies have used double and multiple mutants to devise a logically constant model for DNA repair (reviewed in 71 and 96). These studies are based on identifying and characterizing "epistasis groups". Also, mutants have been characterized with respect to pleomorphic properties such as induced or spontaneous mutation and recombination rates and cross-sensitivity to DNA-damaging treatments.

Double and multiple mutant studies in yeast have proven informative on a number of levels for studying the mitotic action of radiation sensitivity. Not only can complementation groups be determined, but the interactions, with respect to testable parameters, can be investigated.

Regarding radiosensitivity, three different situations arise (40,71,96). Designating a moderately radiation sensitive mutant as radX, an extremely sensitive mutant as radY, and the mutagen sensitivity for the respective strains as LSF(radX) and LSF(radY) (where LSF is log surviving frac-

tion), the interactions are : i) the two genes are in the same epistasis group,  $LSF(\underline{radX} \underline{radY})=LSF(\underline{radY})$ ; ii) the two genes have an additive effect,  $LSF(\underline{radX} \underline{radY}) = LSF(\underline{radX}) + LSF(\underline{radY})$ ; and iii) the two genes affect each other synergistically,  $LSF(\underline{radX} \underline{radY}) > LSF(\underline{radX}) + LSF(\underline{radY})$ . The historical interpretation of these interactions is that epistasis argues for the gene products acting in the same pathway (71). If an early step in a pathway is blocked, inactivating a later step should confer no greater radiosensitivity as a molecular repair intermediate is unable to reach the later step regardless. If each mutation blocks a different pathway or confers sensitivity by different mechanisms, an additive response can be expected for the double mutant (71). Mechanistically, the additivity of two mutations implies that the blocks are due to the recognition and action of the gene products on different radiation-produced substrates (in contrast to the sequential action on the same substrate for epistasis). Synergism, the more than additive interaction of the double mutant, is interpreted as competition between gene products for the same substrate (71). One hypothesis is that damage can be repaired by each pathway in wild-type cells. If a block occurs in one repair pathway, the remaining pathway can compensate by repairing more damage than if both mechanisms were operable. Inactivating both pathways removes the competition and the radiation sensitivity synergism is observed.

While not all complementation groups between mutations conferring radiation and/or chemical sensitivity have been determined, to date more than 100 mutations are known (96). For the repair groups mentioned above, mutants within a group show epistasis, but interact synergistically (occasionally additively) with mutants in other groups when cells are treated with radiation or mutagenic chemicals. Triple mutants, one from each group, show the greatest synergism. Thus, at least three separate pathways are present in yeast for the repair of primary radiation damage (71,96,244).

Regarding UV-induced damage and repair it has been estimated that a dose of  $1 \text{ J/m}^2$  will generate 240 dimers per haploid yeast genome (243). From this, Cox and Game have estimated that the dose required to reduce wild type survival by 63% (one lethal hit per cell) will generate 27,000 dimers per haploid (33). Considering the large number of dimers required per cell-lethal-hit, S. cerevisiae appears extremely proficient in dimer removal. In fact, triple-mutant strains, blocked in all three dark repair epistasis groups and treated with low UV fluences, have survival kinetics whereby one "lethal hit" is observed at less than  $0.01 \text{ J/m}^2$  (33). This has led to estimates, first presented by Unrau et al. (243), that one or two unrepaired dimers can be lethal and supports the contention that the primary UV photoadduct of cyclobutyl dimers are the major source of UV lethality in a yeast cell.



As early as 1954, Saracheck (220) demonstrated in yeast, as in bacteria, that the lethal effects of UV radiation can be photoreactivated. In other words, visible light exposure immediately after UV treatment prevents cell death. The reversal is mediated by a single enzyme, PHR1 (192,223,262), for which a mutant (phr1-1) was isolated in 1969 by Resnick (192). The mutant shows no photoreactivation and lacks enzyme activity. However, the phr1-1 mutation does not affect UV sensitivity of dark incubated cells and therefore is not categorized as a rad mutant nor is it placed in an epistasis group.

The loci of the RAD3 group are primarily UV sensitive, but not ionizing radiation sensitive (96). These mutations generally confer enhanced UV mutagenesis, are sporulation proficient, and show variable levels of spontaneous mitotic recombination and mutation (depending upon the mutation and locus examined). These mutants can undergo meiotic recombination and at least nine loci are known to control error-free excision of dimers (96,101,202,203). The majority of members of the epistasis group have increased mutation rates when treated with UV, but show wild-type levels of X-ray-induced mutation. All of the members examined show elevated levels of UV-induced mitotic recombination. Reynolds and Friedberg (202,203) have demonstrated that rad1 through rad4 and rad14 are defective in the production of single-strand DNA breaks following UV treatment. If UV-treated DNA is

pre-incised in vitro with a dimer-specific nuclease (such as T4 UV endonuclease), then cell extracts of rad1 through rad4, rad7, rad10, rad14, and rad16 strains are capable of completing dimer excision. This suggests that incision or pre-incision stages are defective in these mutant strains.

Studies of the DNA incision reaction for UV damage repair in S. cerevisiae have been complicated by a number of factors. Other than the obvious genetic complexity, the incision at dimers is rapidly followed by excision, resynthesis and ligation. Therefore, detection at time of sampling is low relative to the maximum, potential, total genomic dimer number. To circumvent this problem, Wilcox and Prakash (257) have made use of a CDC mutation conferring conditional DNA ligation (cdc9). Thus, incision and resynthesis associated with the mechanism of dimer removal can be studied by blocking the resealing of the repair tract, allowing the detection of a greater number of strand breaks. In this analysis, Wilcox and Prakash demonstrated that in the cdc9 strain alone, essentially 100% of the potential breaks are observed on alkaline sucrose gradient. The mutants rad1 through rad4 and rad10 demonstrate a total defect (0%) in the incision of UV-treated DNA. Other RAD3 epistasis group members, such as rad7, rad14, rad16, and rad23 are deficient, but not totally defective, for in vivo incision. Thus it appears as if the RAD3 group can be subdivided into two categories. Some genes are required for

DNA incision while others are involved but perhaps not absolutely essential for the process (67,68). Alternatively, the known alleles of rad7, rad14, rad16, and rad23 may be leaky.

A number of RAD genes belonging to the RAD3 epistasis group have been cloned (68,69,99,165-168) to facilitate the isolation of the gene products for biochemical analysis. Clones containing RAD1, RAD2, RAD3, and RAD10 have been obtained (68,69). While DNA sequencing of the coding regions of these genes has led to the conceptual translation, (the genes could encode products of at least  $9 - 13 \times 10^4$  molecular weight), little is known about the precise gene function and the gene products have not been purified.

The RAD3 gene is the most intriguing of the cloned excision-repair genes. The gene has been shown to be essential by gene disruption studies (Figure 4). Insertion of pBR322 and URA3 sequences into the center of the RAD3 coding region, producing a null allele, creates inviable cells (99,168). The nature of the essential function is currently not understood. However, from cloning, sequencing, deletion studies, and analysis of mutant alleles, (68, 69,99,164-167) the essential function is apparently distinct from the incision activity. Mutants entirely defective in DNA incision retain wild-type viability.

While excision-repair appears to account for most dimer repair in wild-type strains (since excision-deficient

Figure 4 Demonstration of the concept of how to show if a cloned gene is essential. Diploid strains are transformed with an integrating plasmid containing an internal fragment of a cloned gene (in the case shown, RAD3). The plasmid integrates by homologous recombination into the corresponding chromosomal region, producing a diploid heterozygous for the disruption. Cells are sporulated and dissected. Germinated cells are examined for viability. If the gene is essential, segregation of 2 viability: 2 inviability is observed. The inviability is linked to selectable markers on the YIp plasmid.

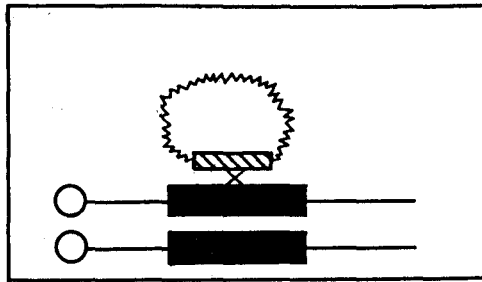

■ = RAD3

▨ = internal fragment of RAD3

~ = pBR322

Integration

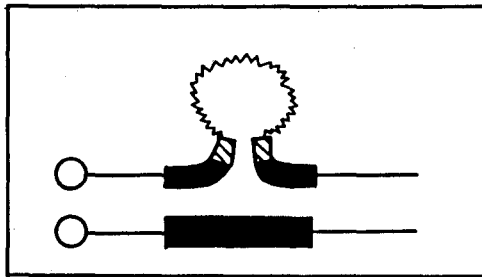

Sporulation  
Dissection  
Germination

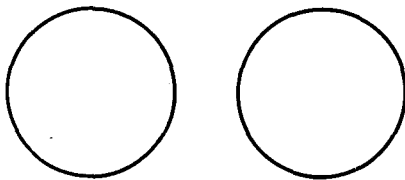

2 Live Spores  
(RAD3)



2 Dead Spores  
(rad3::null)

strains tend to be the most UV-sensitive), other non-excision repair UV-sensitive mutants have been isolated (71,96,183,184). Loci of the RAD6 group are UV and X-ray sensitive and are involved in error-prone recovery (71,96,183,244). Other than rad6-1, members of this group are only moderately sensitive to UV, X-ray, and genotoxic chemicals. Strains containing mutations from the RAD6 group are proficient in dimer excision and the majority (8/12) can sporulate (96). All members show decreased UV or chemically-induced mutation rates. There is locus-dependent fluctuation in spontaneous mutation and X-ray stimulated mutation rates vary (96). The frequency of spontaneous mitotic recombination varies among the members of the group, but most RAD6 group mutant strains show enhanced mitotic recombination levels when treated with UV or ionizing radiation (96).

McKee and Lawrence have proposed subcategorization of the RAD6 group based on phenotypic comparisons (155). The first subgroup would contain RAD6 alone. This gene functions in the error-prone repair of lesions produced by most mutagens examined (96,184,244). An implication for the role of RAD6 in postreplication-repair can be drawn from the work of Prakash (181,182). She examined the size of newly synthesized DNA in various mitochondrial-less, excision-repair-deficient strains following UV treatment. Initially, the molecular weight corresponds to interdimer distances. With time in growth medium, the molecular weight of newly

synthesized DNA increases to unirradiated size. Prakash found that rad6-1 blocks the postreplicational increase in daughter strand molecular weight but that rad18 and rad52 (discussed below) only partially inhibit the increase. She suggested more than one repair mechanism plays a role in postreplication-repair in S. cerevisiae, with recombinational and non-recombinational (error-prone) modes being involved.

While rad6 mutants are highly sensitive to DNA damage, mutation is non-inducible by any agent in these strains (71, 96,184,244). An interesting observation is that UV resistance in rad6-1 can be restored by ochre suppression, but mutability is not restored by this suppression (160). Different alleles of RAD6 also present varying phenotypes. Although both known alleles of RAD6 (rad6-1 and rad6-3) are proficient in mitotic recombination (144,160) only one allele, rad6-1, is deficient in meiotic recombination and sporulation. Perhaps mutational ability and recombinational proficiency are independent.

Continuing the subcatagorization of the RAD6 epistasis group, the second subgroup is the RAD18 locus. Strains containing rad18 accumulate single and double-strand breaks after ionizing radiation treatment (96). In one study, these strains are claimed to be partially defective in dimer excision, and rad18 stocks show altered mitotic gene conversion frequencies (12). Reynolds and Friedberg examined

excision-repair steps in rad18 cells and were unable to demonstrate any nuclease deficiency in comparison with wild-type or excision-repair-deficient (RAD3 group) mutants (202,203). Therefore, the dimer removal deficiency may reflect a role of RAD18 in error-free repair that is RAD6 dependent and, based on the previously mentioned work of Prakash, RAD18 may be involved in recombinational postreplication repair.

The third and fourth subgroups are an ill-defined set of mutations that, for group three, include RAD9 and RAD15 (96). Strains mutated at these loci are only moderately sensitive to chemical agents like MMS (Methyl Methane Sulfonate) and, where examined, show wild type levels of spontaneous and UV-induced mitotic recombination (96). Thus, the mode of recovery, error-prone or error-free, appears to depend upon the nature of the damage.

The fourth subgroup of the RAD6 epistasis group contains the REV and UMR loci (96). Mutations in these loci confer only moderate sensitivities to radiation or chemical agents, but are deficient in UV and chemically-stimulated mutation, where examined (96). These genes appear to be solely involved in error-prone repair.

The epistasis group most interesting to persons studying genetic recombination is the RAD52 group. This group, unlike the RAD3 and RAD6 groups, is sensitive primarily to X-rays (71,74,96,186). Most mutants affect sporula-



tion and recombination and are generally depressed for UV and chemically-induced mutation (71,96,182). Strains with rad50, rad51, rad52, rad54, or rad57 cannot repair DNA double-strand breaks (71,193,195,198, J. Nitiss, personal communication). It appears as if double-strand breaks, regardless of how chain cleavage is generated, is the dominant lethal form of damage. A single unrepaired double-strand break in yeast is lethal. The basis for this argument comes from the work of Malone and Esposito (141). It is known that mating type switching in S. cerevisiae involves a site-specific unique double-strand cleavage at the mating type locus, mediated by the HO endonuclease (125,126). Malone and Esposito (141), and Haber's group (250,251), demonstrated that rad52-1 strains are unable to perform homothallic mating type switching, and that the attempt to switch in the absence of RAD52 can lead to cell death.

Further evidence that the dominant lethal damage is a double-strand break comes from the work of Barnes and Rine (8). In an attempt to find nuclear-pore mutants, they constructed a galactose-inducible EcoRI endonuclease that functions in yeast. Wild type cells, grown in galactose, were able to tolerate this construct. Strains containing rad52-1 were inviable upon induction of the endonuclease, reinforcing the notion that a double-strand cleavage is the lethal damage.

Game has subdivided the RAD50 epistasis group into two categories (71). The RAD52 subgroup contains RAD51, RAD52, and RAD54, while the loci RAD50, RAD53, RAD55, RAD56, and RAD57 are in the second.

The RAD52 subgroup is highly X-ray sensitive, while the second subgroup is somewhat less sensitive (71, 96). Double mutants show that rad52-1 is epistatic to the RAD50-containing group (71,134). Homothallic strains carrying mutations in the RAD52 subgroup are either inviable or fail to switch mating-types, while other X-ray sensitive mutants, like rad50 and rad57, are switching proficient. Interestingly, those mutants unable to switch also demonstrate the strongest block in mitotic and meiotic recombination. In fact, rad50 strains are hyper-rec in mitosis (Chapter 2 and reference 139). Perhaps homothallic switching uses enzymes with a role in spontaneous mitotic recombination.

Currently, there is little biochemical information regarding the precise function of any yeast RAD gene. However, many RAD genes have been cloned over the past few years. Some of the genes have been sequenced and predicted amino acid sequences are available. It is hoped that ongoing studies will reveal the nature of the encoded proteins and the precise action of the functions in normal cellular metabolism and the handling of environmental insults.

The RAD series of genes are not the only functions

that, when mutated, affect mitotic recombination and/or DNA repair. Esposito and co-workers have used a hyperhaploid  $n+1$  strain, disomic for chromosome VII, to isolate hypo- and hyper-rec mutations affecting spontaneous mitotic gene conversion and intergenic recombination (46). They isolated five classes of rec mutants following UV mutagenesis.  $Rec^-$  mutants that simultaneously affected conversion and intergenic recombination were detected, suggesting that these processes are under joint genic control during mitosis. Conversion-specific and intergenic recombination-specific recombination mutants were also isolated, indicating that these phenomena can be separated. Group I mutants exhibit reduced levels of gene conversion and crossing-over and are therefore defective in coordinate control. Group II mutants are conversion proficient but reduced in intergenic recombination, indicating the existence of REC genes responsible for mitotic crossing-over. Group III mutants are proficient for gene conversions but are intergenic hyper-recs and illustrates that mutated REC genes can affect crossing-over without affecting conversion. Group IV is the inverse of group II and is decreased in mitotic gene conversion but is intergenic recombination proficient. Therefore, this class demonstrates conversion can be uncoupled from crossing-over in the analogous, but opposite, fashion to group II's uncoupling of crossing-over from conversion. The final class, Group V, exhibits enhanced conversion and crossing-

over. This group, with phenotypes similar to rem1 (79-82, 142,144) (discussed below), also demonstrates the coordinate genic control of crossing-over and conversion.

Esposito and Bruschi have speculated, on the basis of the rec mutant's phenotypes, for potential roles of each group in the mechanism of genetic recombination (46). Groups I-III have been assigned no specific functions other than a defect in any of the stages of heteroduplex formation, establishment of Holliday structures, or resolution of Holliday structures. Group IV, however, may reflect a defect in mismatch repair, involved in heteroduplex resolution. Group V, the class with a general spontaneous hyper-rec phenotype, has been proposed to be a manifestation of increased initiation of mitotic recombination (46).

#### Introduction to Experimentation

Experiments presented in this dissertation are directed towards understanding the processes of spontaneous mitotic recombination and DNA repair. A major portion of the research is dedicated to the analysis of REM1 (RAD3). Mutations in REM1 confer a semi-dominant, hyper-rec, hyper-mutable phenotype that is mitosis-specific (79-82,142,143). The procedure for following the rem1 phenotype in meiotic segregants is given in Figure 5. This figure demonstrates the level of rem1-produced, semi-dominant, hyper-recombination. The first allele, rem1-1, was reported by Golin and Esposito as evidence for the joint genic control of sponta-

Figure 5 How to follow segregation of rem1-2. Meiotic segregants are mated with a lawn of tester spores (TX or TY). TX and TY are homothallic strains containing specific auxotrophic and drug-resistance markers. By mating segregants with TX or TY, multiple heteroallelic and heterozygous marker configurations are available for diagnosing the rem1 phenotype. Diploids are selected by complementation on adenine omission medium and have a number of heteroallelic and heterozygous drug-resistance markers. Due to the semi-dominance of rem1-2, segregants containing rem1 produce more recombinant papillae than those with REM1. By using nine different media, segregation is followed with greater confidence.

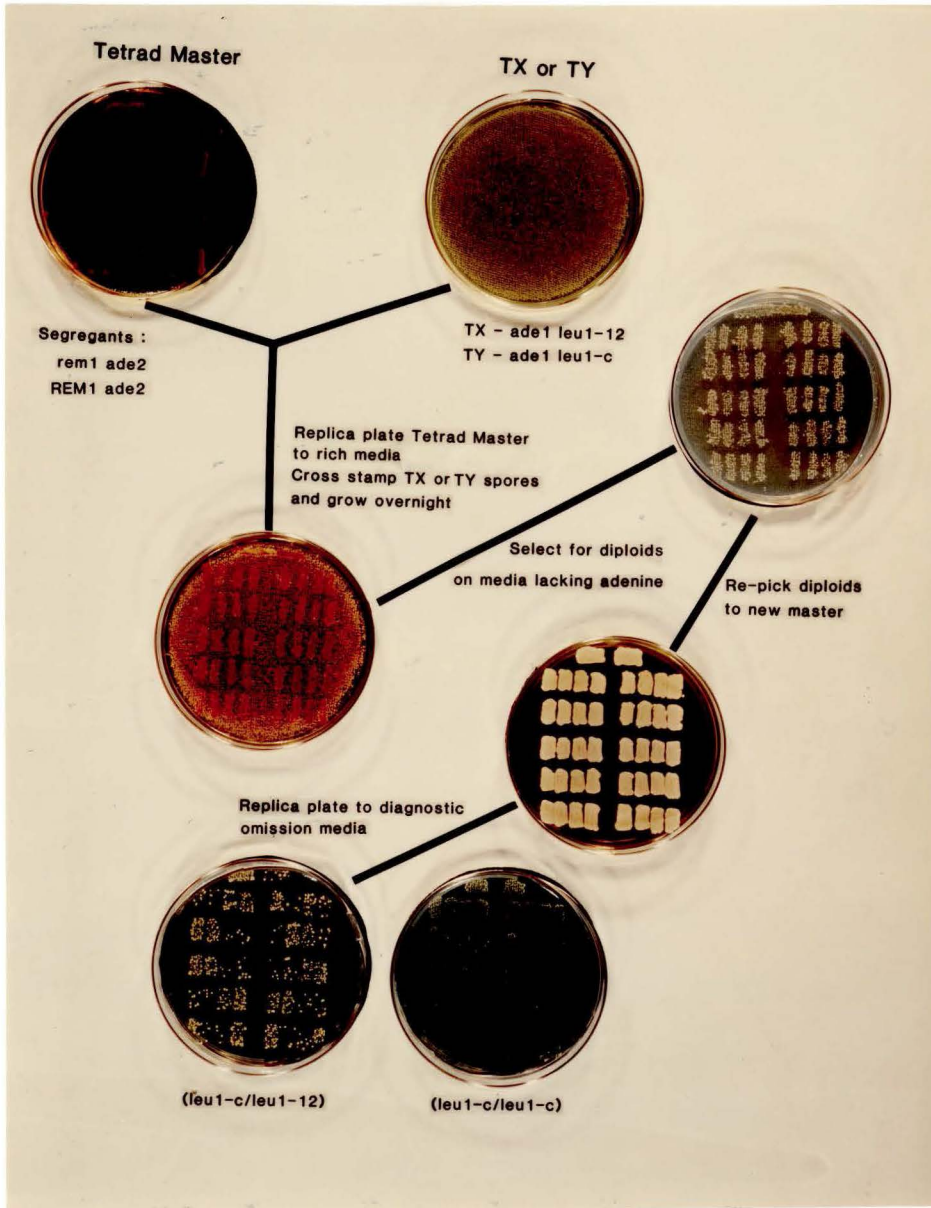

neous mitotic recombination and mutation (79-82, 142). The mutation was used as a tool to enhance spontaneous recombination for the elucidation of the two-strand model for mitotic recombination described earlier (45,59,79). Malone, Golin and Esposito (142) examined the properties of recombination in rem1-1 and noted that the distribution of cross-overs was such that the mitotic map of chromosome VII was altered (Figure 32, Chapter 8). The centromere region of this chromosome had a distribution of cross-overs intermediate between the meiotic and wild type mitotic maps. (A meiotic map demonstrates centromeric compression relative to the mitotic map.) This led to the proposal that the mechanism of the mitotic phenotype of rem1 might be due to the "turning-on" of meiotic functions during mitosis (142,143).

A second allele of REM1, rem1-2, was isolated in our laboratory during a screen for mutations affecting spontaneous mitotic recombination (Chapter 2, reference 143). Using this allele, the specific prediction of a mitotic "turning-on" of meiotic functions was tested. The approach, described in a later chapter, was to use meiotic recombination deficient mutants. Based on the success of Malone and Esposito with the spol3 bypass system for meiotic recombination (141), an extensive characterization of the interactions between rem1 and mutations in the excision-repair, error-prone repair, and double-strand break repair epistasis groups was presented. While examining double and

multiple mutants, it was discovered that the rem1-1 and rem1-2 mutations are alleles of RAD3. This was an unexpected discovery as currently known RAD3 mutations are exquisitely UV sensitive while the rem1 alleles of RAD3 are UV resistant (Chapters 3, 4 and 8).

The RAD3 gene has been cloned by both Freidberg's group and Prakash's group (68,69,99,165-168). A clone of the REM1 gene was isolated during the course of this work and has proven to be identical to Friedberg's clone. The clone, contained originally on pMFH100, complements the UV sensitive alleles of RAD3 and the hyper-rec alleles known as rem1.

The rad52-1 mutation was used in part of the work analyzing rem1. The rad52-1 mutation confers a general Rec<sup>-</sup> phenotype (74,140,186). It is deficient in mitotic and meiotic gene conversion and, according to some, defective in crossing-over (140). Work from Szostak's lab has demonstrated selected plasmid chromosome recombination is present in rad52 strains (172). Recent evidence refutes this observation in that unselected plasmid - chromosome recombination cannot be detected by Southern blot analysis (Chuck Edwards, Masters Thesis, Loyola University of Chicago). Also, rad52 strains are defective in a specific intrachromosomal recombination event -- mating-type switching (141,251,252), but sister chromatid exchange is present in rad52-1 cells (185, 263). While examining the properties of rem1-2 and rad52-1,



it was noted that various heteroalleles recombined at a similar frequency in rad52-1 strains (Chapter 5 and reference 140). In wild-type cells, the same heteroalleles show a wide range of recombination frequencies (Chapter 5, references 140 and 143). This observation has been investigated further by examining recombination at a set of six alleles along the length of the LYS2 gene. These alleles, four of which were isolated during the course of this dissertation, span along the length of the LYS2 gene. The pairwise combinations recombine at varied frequencies in wild type cells. Strains containing rad52-1 do recombine the heteroalleles, at rates greater than reversion or suppression of the input alleles, but the fluctuation present in wild-type is greatly reduced.

Finally, considering the fact that cells respond to environmental insults by increasing somatic recombination frequencies, one proposal for the mechanism of rem1's action was that it was an analogue of E. coli's methyl-directed mismatch repair system (7,150,152,189). (A comparative discussion of rem1 and dam is given in Chapter 2.) In other words, the rem1 mutated function might over-methylate DNA causing enzymes involved in mismatch repair act more frequently. During this study, an S. cerevisiae shuttle vector containing the E. coli dam gene became available (15) and it was determined if S. cerevisiae responds to a previously non-encountered DNA modifying agent -- N-6-methyladenine.

While work was ongoing, Hattman's group contradicted their earlier work (93) and demonstrated that yeast cells contain extremely low levels of DNA methylation (188). Later, it was also demonstrated that the rem1 mutations are alleles of RAD3, a function involved in the incision or pre-incision step of excision-repair (202,203). Therefore, it seems unlikely that rem1 mutations increase DNA methylation. However, it was decided to continue the examination of dam-produced methylation in yeast as a means of discerning the properties of the various repair groups. It was found that cells do respond to dam-created methylation and a stimulation of recombination and mutation is observed (Chapter 6 and reference 103). Introducing the dam gene to strains defective in excision-repair shows that N-6-methyladenine is recognized and responded by excision-repair mechanisms.

The study of mitotic recombination was initially stimulated by examining the affects of DNA damaging treatments upon mitotic cells. This led to the examination of the effects of radiation-sensitive mutations on recombination and finally the isolation of mutants like rem1, which are proficient in radiation damage repair but altered in spontaneous mutability and recombination. The demonstration that dam-produced N-6-methyladenine is recognized at the level of RAD3 ties-in directly with the analysis, at a genetic, biochemical, and molecular level, of the rem1

alleles of RAD3.

## CHAPTER II

### RELATIONSHIPS BETWEEN A HYPER-REC MUTATION (rem1) AND OTHER RECOMBINATION AND REPAIR GENES IN YEAST<sup>1</sup>

#### ABSTRACT

Mutations in the REM1 gene of Saccharomyces cerevisiae confer a semidominant hyper-recombination and hypermutable phenotype upon mitotic cells (80). These effects have not been observed in meiosis. We have examined the interactions of rem1 mutations with each of rad6-1, rad50-1, rad52-1 or spoll-1 mutations in order to understand the basis of the rem1 hyper-rec phenotype. The rad mutations have pleiotropic phenotypes; spoll is only defective in sporulation and meiosis. The RAD6, RAD50 and SPO11 genes are not required for spontaneous mitotic recombination; mutations in the RAD52 gene cause a general spontaneous mitotic Rec<sup>-</sup> phenotype. Mutations in RAD50, RAD52 or SPO11 eliminate meiotic recombination, and mutations in RAD6 prevent spore formation. Evidence for the involvement of RAD6 in meiotic recombination is less clear. Mutations in all three RAD genes confer sensitivity to X-rays; the RAD6 gene is also required for UV damage repair. To test whether any of these

<sup>1</sup> R. E. Malone and M. F. Hoekstra, (1984). Genetics 107:33-48.

functions might be involved in the hyper-rec phenotype conferred by rem1 mutations, double mutants were constructed. Double mutants of rem1 spoll were viable and demonstrated rem1 levels of mitotic recombination, suggesting that the normal meiotic recombination system is not involved in production the rem1 phenotype. The rem1 rad6 double mutant was also viable and had rem1 levels of mitotic recombination. Neither rem1 rad50 nor rem1 rad52 double mutants were viable. This suggests that rem1 causes its hyper-rec phenotype because it creates lesions in the DNA that are repaired using a recombination-repair system involving RAD50 and RAD52.

## INTRODUCTION

The study of mutants with increased levels of recombination in Escherichia coli has led to greater understanding of a number of genes involved in DNA metabolism. Mutations with an increased recombination (hyper-rec) phenotype in E. coli include lesions in the polA, lig, uvrD, dut and dam genes (4,7,123,150,242). In the presence of many of these mutations, the recombination that occurs appears to be essential. For example, double mutants of polA or dam and either recA or recB mutations are not viable (87,152). On the other hand, recA uvrD double mutants are viable but are no longer hyper-rec (4). All of these hyper-rec mutations cause nicks, gaps or breaks in the DNA, which presumably stimulate recombination. In addition to their hyper-rec phenotype, most of these mutants also cause a hypermutable phenotype. In the case of the polA and lig mutations, this may be due to the induction of the SOS (error-prone) repair systems (123). In the case of dam mutations it appears to be due, at least in part, to the loss of methyl-directed mismatch repair (77,189). Second site revertants of dam mutations (mutH, mutL, mutS) that reduce the hyper-rec phenotype but increase the hypermutable phenotype of dam mutations are apparently defective in mismatch base repair (77). Since hyper-rec mutations in E. coli have given considerable insight into recombination and repair processes, we have isolated and studied a hyper-rec mutation in

saccharomyces cerevisiae in the hope that it would be of similar utility in yeast.

The REM1 gene was originally defined by the rem1-1 allele isolated by Golin and Esposito (80). It was initially isolated as a mutation that conferred a hypermutable phenotype and was found to also increase mitotic recombination (77). It caused no significant increase (or decrease) in meiotic recombination (77). The mutant allele rem1-1 was semi-dominant: heterozygous rem1-1/REM1 diploids displayed approximately 50% of the increases in recombination and mutation found in homozygous rem1-1/rem1-1 diploids. Using a direct screen for mutants affecting mitotic recombination, we isolated a mitotic hyper-rec mutation, rem1-2, which is allelic with rem1-1. Like rem1-1, it is hyper-rec, hypermutable and semidominant. One hypothesis to explain the hyper-rec phenotype of rem1 mutations is that it leads to the appearance of the meiotic recombination system in mitotic cells. The frequency of meiotic recombination in yeast is several orders of magnitude greater than mitotic recombination. Thus, the presence of meiotic recombination functions in mitotic cells might lead to increased levels of mitotic recombination. Some support for this notion comes from the observation that rem1 mutant strains have a distribution of cross-over events that is intermediate between that which normally occurs in mitosis and that which occurs in meiosis (142). An alternative hypothesis is that

the presence of rem1 mutations leads to lesions in the DNA that stimulate recombination and produce mutations. We suppose that in yeast, as in E. coli, these recombinogenic defects might be nicks, gaps or breaks in the DNA. This second hypothesis also suggests the possibility that one (or many) of the known repair systems in yeast may be required for expression of the  $Rem^-$  phenotype. The experiments presented in this paper test these hypotheses by determining the effect of various  $Rec^-$  and repair defective mutations on strains containing rem1.

Recombination and repair pathways in yeast are complex, and many mutations affecting these processes have pleiotropic phenotypes (for reviews, see references 50,63, 96). Recombination can occur in meiosis, and, at a lower frequency, in mitosis; the two recombination processes share some functions, whereas others are specific for meiotic recombination (see following data). Haynes and Kunz (96) propose that dark repair functions can be loosely grouped into three major epistasis groups (or pathways): the RAD3 group (primarily responsible for UV excision repair), the RAD52 group (primarily responsible for double-strand break repair and thought to be a recombination-repair pathway) and the RAD6 group (an error-prone repair system).

The mutations used to study rem1 were rad50-1, rad52-1, spoll-1 and rad6-1; their phenotypes are summarized in Table 1. The rad50 mutant phenotypes suggest that the



Table 1 Properties of mutations used to study reml

Mutation	Repair Defect	Repair Epistasis Group	Spontaneous Mitotic Recombination Between Homologs	Meiotic Recombination Between Homologs
<u>rad6-1</u>	UV sensitive <sup>a,b</sup> X-ray sensitive <sup>a</sup>	<u>RAD6</u> Error-Prone Repair <sup>a,b</sup>	Present <sup>c,d</sup>	Sporulation Defective <sup>e</sup> Recombination Defective <sup>e,f</sup>
<u>rad50-1</u>	X-ray sensitive <sup>g</sup>	<u>RAD52</u> Double-strand Break Repair	Present <sup>h</sup>	Sporulation Defective <sup>e</sup> Recombination Deficient <sup>e,h</sup>
<u>rad52-1</u>	X-ray sensitive <sup>g</sup>	<u>RAD52</u> Double-strand Break Repair	Deficient <sup>i,j</sup>	Sporulation Defective <sup>e</sup> Recombination Deficient <sup>e,h,i</sup>
<u>spoll-1</u>	None <sup>k</sup>	None	Present <sup>l,m</sup>	Sporulation Defective <sup>l</sup> Recombination Deficient <sup>l</sup>

A review of the properties of repair genes in yeast is given in Haynes and Kunz (96). Some specific references are: <sup>a</sup>Prakash (181); <sup>b</sup>Prakash (181); <sup>c</sup>Saeki *et al.* (216); <sup>d</sup>Malone (unpublished results); <sup>e</sup>Game *et al.* (74); <sup>f</sup>Malone (139); <sup>g</sup>Game and Mortimer (72); <sup>h</sup>Malone and Esposito (142); <sup>i</sup>Prakash *et al.* (186); <sup>j</sup>Malone and Esposito (140); <sup>k</sup>Klapholz (117); <sup>l</sup>Klapholz and Esposito (120); <sup>m</sup>Bruschi and Esposito (16).

RAD50 gene may be a meiotic recombination function that is also used in mitotic repair processes. The properties of the rad52-1 mutation suggest that the RAD52 gene product may be a general recombination function in mitosis and meiosis; the repair defect of rad52 mutants reflects the role of RAD52 in recombination repair. The rad6-1 mutation confers sensitivity to a large number of DNA damaging agents (UV, X-ray, methyl methane sulfonate (MMS), etc.); it is required for almost all induced mutagenesis, the implication being that it plays a central role in error-prone repair in yeast (181,182). Its role in meiotic recombination is less clear, although it does abolish sporulation (74,139). It seems certain that RAD6 is required for repair and induced mutagenesis but not for spontaneous mitotic recombination.

## MATERIALS AND METHODS

### Yeast Strains

The relevant genotypes of the strains used are shown in Table 2. Strains containing rem1-1, and rem1-2 were constructed by performing several backcrosses with REM1 laboratory stocks in order to develop relatively isogenic backgrounds. The rem1-1 mutation was obtained from JG25-26A, kindly supplied by John Golin (University of Oregon). Some of the strains used in backcrosses were K264-5B and K264-10B (obtained from Sue Klapholz, University of Chicago); others were standard wild-type strains used in our laboratory. Many of the experiments described were performed using different (although related) genetic backgrounds in order to reduce the possibility that strain backgrounds affected the gene interactions; we found similar effects in all backgrounds. Linkage relationships of the genetic loci used are shown:

<p>II    <u>    0    lys2    tyr1    his7    </u>            53          39          51</p>	<p>III    <u>    0    MAT    </u>            25</p>
<p>IV    <u>    0    rad50    </u>            145</p>	<p>V    <u>  can1    ura3    0    hom3    his1    </u>            44          8    56          3</p>
<p>VII    <u>  ade5    met13    cyh2    rad6    trp5    leu1    0    ade6    </u>            81          15          54          24          18          3    29</p>	
<p>VII    <u>  spo11    0    </u>            21</p>	<p>XIII    <u>  rad52    0    </u>            16</p>
	<p>XV    <u>    0    ade2    </u>            88</p>

The roman numerals refer to the chromosome number, and the numbers below the line refer to map distances between loci (163). Gene symbols are defined by Plischke *et al.* (178);

Table 2 Genotypes of strains

Diploid	Relevant Genotype									
MH1	a	<u>rem1-2</u>	<u>spoll-1</u>	<u>ade2-1</u>	<u>lys2-1</u>	<u>tyr1-2</u>	<u>his7-1</u>	<u>CAN1<sup>S</sup></u>	<u>ura3-1</u>	+
	α	<u>rem1-2</u>	<u>spoll-1</u>	<u>ade2-1</u>	<u>lys2-1</u>	<u>tyr1-2</u>	<u>his7-2</u>	<u>can1<sup>R</sup></u>	<u>ura3-13</u>	<u>hom3</u>
	<u>+ met13-c cyh2<sup>R</sup> trp5-c leul-c ade6</u> <u>ade5 met13-d CYH2<sup>S</sup> trp5-c leul-12 +</u>									
MH2	a	<u>rem1-2</u>	<u>spoll-1</u>	<u>ade2-1</u>	+	<u>tyr1-2</u>	<u>his7-1</u>	<u>CAN1<sup>S</sup></u>	<u>ura3-1</u>	+
	α	<u>rem1-2</u>	<u>spoll-1</u>	<u>ade2-1</u>	<u>lys2-1</u>	<u>tyr1-2</u>	<u>his7-2</u>	<u>can1<sup>R</sup></u>	<u>ura3-13</u>	<u>hom3</u>
	<u>+ met13-c cyh2<sup>R</sup> trp5-c leul-c</u> <u>ade5 met13-d CYH2<sup>S</sup> trp5-c leul-12</u>									
MH3	a	<u>rem1-2</u>	+							
	α	+	<u>rad52-1</u>							
MH4	a	<u>rem1-2</u>	<u>ade2-1</u>	<u>lys2-2</u>	<u>tyr1-2</u>	+	<u>CAN1<sup>S</sup></u>	<u>ura3-1</u>		
	α	<u>rem1-2</u>	<u>ade2-1</u>	<u>lys2-1</u>	<u>tyr1-2</u>	<u>his7-2</u>	<u>can1<sup>R</sup></u>	<u>ura3-13</u>		
	<u>+ met13-c rad6-1 trp5-c leul-c ade6</u> <u>ade5 met13-d rad6-1 trp5-2 leul-12 +</u>									
MH5 - MH8	a	<u>rem1-1</u>	+							
	α	+	<u>rad52-1</u>							
MH9 - MH12	a	<u>rem1-2</u>	+							
	α	+	<u>rad52-1</u>							

Table 2 Genotype of strains (continued)

MH13	<u>a</u>	<u>spoll-1</u>	<u>ade2-1</u>	<u>lys2-1</u>	<u>tyr1-2</u>	<u>his7-1</u>	<u>ade5</u>	<u>met13-c</u>	<u>cyh2<sup>R</sup></u>	<u>trp5-c</u>	<u>leul-c</u>
	<u>α</u>	<u>spoll-1</u>	<u>ade2-1</u>	<u>lys2-2</u>	<u>tyr1-2</u>	<u>his7-1</u>	+	<u>met13-c</u>	<u>cyh2<sup>R</sup></u>	<u>trp5-c</u>	<u>leul-c</u>
MH14	<u>a</u>	<u>spoll-1</u>	<u>ade2-1</u>	<u>lys2-1</u>	<u>tyr1-2</u>	<u>his7-1</u>	<u>ade5</u>	<u>met13-c</u>	<u>cyh2<sup>R</sup></u>	<u>trp5-c</u>	<u>leul-c</u>
	<u>α</u>	<u>spoll-1</u>	<u>ade2-1</u>	<u>lys2-1</u>	<u>tyr1-2</u>	<u>his7-1</u>	+	<u>met13-c</u>	<u>cyh2<sup>R</sup></u>	<u>trp5-c</u>	<u>leul-c</u>
MH15	<u>a</u>	<u>rem1-2</u>	<u>ade2-1</u>	+	<u>tyr1-1</u>	<u>his7-2</u>	<u>CAN1<sup>S</sup></u>	<u>ura3-13</u>	<u>ade5</u>	<u>met13-d</u>	<u>trp5-2</u>
	<u>α</u>	<u>rem1-2</u>	<u>ade2-1</u>	<u>lys2-2</u>	<u>tyr1-2</u>	<u>his7-1</u>	<u>can1<sup>R</sup></u>	<u>ura3-1</u>	+	<u>met13-c</u>	<u>trp5-c</u>
RM13	<u>a</u>	<u>ade2-1</u>	<u>CAN1<sup>S</sup></u>	<u>ura3-13</u>	<u>hom3</u>	+	+	<u>met13-c</u>	<u>cyh2<sup>R</sup></u>	<u>trp5-c</u>	<u>leul-c</u>
	<u>α</u>	<u>ade2-1</u>	<u>can1<sup>R</sup></u>	<u>ura3-1</u>	+	<u>his1</u>	<u>ade5</u>	+	<u>CYH2<sup>S</sup></u>	<u>trp5-2</u>	<u>leul-12</u>
		+	<u>tyr1-1</u>								
		<u>lys2-1</u>	+								
RM15	<u>a</u>	<u>ade2-1</u>	<u>CAN1<sup>S</sup></u>	<u>ura3-1</u>	+	<u>met13-c</u>	<u>cyh2<sup>R</sup></u>	<u>trp5-c</u>	<u>leul-c</u>	<u>ade6</u>	
	<u>α</u>	<u>ade2-1</u>	<u>can1<sup>R</sup></u>	<u>ura3-13</u>	<u>ade5</u>	<u>met13-d</u>	<u>CYH2<sup>S</sup></u>	<u>trp5-2</u>	<u>leul-12</u>	+	
		<u>lys2-2</u>	<u>tyr1-2</u>	<u>his7-1</u>							
		<u>lys2-1</u>	<u>tyr1-1</u>	<u>his7-2</u>							
RM27	<u>a</u>	<u>HO</u>	<u>ade2-1</u>	<u>can1<sup>R</sup></u>	<u>ura3-13</u>	<u>ade5</u>	<u>met13-d</u>	<u>CYH2<sup>R</sup></u>	<u>trp5-2</u>	<u>leul-12</u>	
	<u>α</u>	<u>HO</u>	<u>ade2-1</u>	<u>CAN1<sup>S</sup></u>	<u>ura3-1</u>	+	<u>met13-c</u>	<u>cyh2<sup>R</sup></u>	<u>trp5-c</u>	<u>leul-c</u>	
		<u>lys2-1</u>	<u>tyr1-1</u>	<u>his7-2</u>							
		<u>lys2-2</u>	<u>tyr1-2</u>	<u>his7-1</u>							
RM33	<u>a</u>	<u>rem1-2</u>	<u>ade2-1</u>	<u>CAN1<sup>S</sup></u>	<u>ura3-1</u>	+	<u>met13-c</u>	<u>cyh2<sup>R</sup></u>	<u>trp5-2</u>	<u>leul-c</u>	<u>ade6</u>
	<u>α</u>	<u>rem1-2</u>	<u>ade2-1</u>	<u>can1<sup>R</sup></u>	<u>ura3-13</u>	<u>ade5</u>	<u>met13-d</u>	<u>CYH2<sup>S</sup></u>	<u>trp5-2</u>	<u>leul-12</u>	+
		<u>lys2-1</u>	<u>tyr1-2</u>	<u>his7-2</u>							
		<u>lys2-2</u>	<u>tyr1-1</u>	<u>his7-1</u>							

Table 2 Genotype of strains (continued)

---

RM81 -	<u>a</u>	<u>rem1-2</u>	<u>+</u>
RM83	$\alpha$	+	rad50-1
RM92 and	<u>a</u>	<u>rem1-2</u>	<u>+</u>
RM93	$\alpha$	+	rad6-1
RM94 and	<u>a</u>	<u>rem1-2</u>	<u>+</u>
RM95	$\alpha$	+	spoll-1

---

the position of the centromere is represented by a circle.

### Media and techniques

The recipes for all media used have been previously described (75). Dropout media are synthetic complete media lacking a specific growth requirement (e.g., URA dropout is complete media lacking uracil). MMS plates, used to follow segregation of rad6-1, rad50-1, and rad52-1, are YPD plates containing 0.01% MMS (Eastman Kodak); strains containing these mutations do not grow on MMS plates. Standard techniques were used for sporulation, dissection, testing of auxotrophic requirements and prototrophic selection of diploids (47,48). Segregation of spoll-1 was followed by complementation tests with known spoll-1 tester strains; the diploids formed were assayed for their ability to sporulate and/or for their level of meiotic chromosome segregation (120). Segregation of reml-1 and reml-2 was followed by a mitotic recombination assay. Spore clones were crossed to tester strains containing different heteroalleles and drug resistance markers; the resulting diploids were tested for mitotic recombination by replica plating to appropriate selective media. Diploids with the reml mutation exhibit a 10- to 50-fold increase in recombinant papillae when compared with wild-type strains.

### Isolation of reml-2

The reml-2 mutation was isolated during a screen for

mutations affecting spontaneous mitotic recombination. The diploid RM13 was mutagenized with ethyl methane sulfonate (Eastman Kodak) to a survivor level of 55% and the diploid cells plated on YPD (rich) medium. Approximately 1200 colonies were picked, and small patches were made on YPD "master" plates. After growth, each of these plates was then replicated to a series of dropout media to monitor mitotic gene conversion at the heteroallelic loci present in RM13. In addition, the masters were replicated to media containing either the drug canavanine sulfate (United States Biochemical Corporation) or cycloheximide (Sigma) in order to monitor reciprocal recombination levels (see following data). Twelve clones that exhibited mitotic hyper-rec phenotypes at all diagnostic loci were detected. After single colony purification and retesting, six mutants retained their hyper-rec phenotype. The six strains were sporulated, and random spores were isolated. When the mutants were outcrossed to wild-type haploids, one of the six mutants gave rise to spores that conferred a hyper-rec phenotype, even though it was present in a heterozygous state. Subsequent analysis of the mutation showed that it segregated in a 2:2 fashion and was semidominant. The level of mitotic recombination in a heterozygote was approximately midway between the wild-type and the homozygous mutant strain. When CAN1<sup>S</sup> mutant strains were replica plated to medium containing canavanine, more can1<sup>R</sup> papillae were



observed than in wild-type strains. This suggested that the mutant increased mutation rate, and it was crossed to rem1-1. Forty-five tetrads were examined, and all segregated 4:0 for the hyper-rec and hypermutable phenotype. From these data we conclude that the mutation is an allele of the REM1 locus and have designated it rem1-2. Like rem1-1, analysis of rem1-2 diploids showed no effect on meiotic map distances.

#### Determination of mitotic recombination frequencies

Single colonies from recently constructed diploids were picked into 1 ml of sterile deionized water, and cell concentration determined by hemacytometer count. Approximately 25 cells/ml were inoculated into 35 ml of YPD broth. The culture was grown at 30° with vigorous shaking until a cell concentration of approximately  $2 \times 10^7$  cells/ml was reached. Each culture was inoculated from an independent colony. In most cases, several independent diploids were used. After they were harvested by centrifugation, cells were washed twice in an equal volume of sterile 0.2 M phosphate buffer (pH 7.5), sonicated briefly to disrupt clumps and plated at various dilutions on YPD, complete medium, dropout media lacking various auxotrophic requirements, complete medium containing cycloheximide or arginine dropout medium containing canavanine. Plates were scored after 3 days of incubation at 30° C. To monitor mitotic gene conversion, we have measured the frequency of prototrophs in

diploids containing pairs of auxotrophic alleles (e.g. his7-1/his7-2). Such intragenic or heteroallelic recombination occurs primarily by gene conversion in yeast (50). To monitor mitotic crossing-over, we measured the frequency of drug-resistant cells in diploids heterozygous for a recessive drug resistance locus. For example, a CAN1<sup>S</sup>/can1<sup>R</sup> diploid is sensitive to canavanine. A cross-over event between the CAN1 locus and the centromere can lead to a homozygous can1<sup>R</sup>/can1<sup>R</sup> cell. Loss of the chromosome containing the dominant, sensitive allele would also generate a resistant cell. Where possible, we attempted to control for this by checking for expression of recessive alleles on the same chromosome as the drug-resistant locus. We examined both centromere-proximal recessive markers and recessive markers on the opposite arm wherever possible. In those strains that could be tested, none of 50 colonies (resistant to either drug) examined showed any evidence for chromosome loss.

## RESULTS

The hyper-rec phenotype of rem1 mutations does not depend upon the SPO11 meiotic recombination function

To determine whether the hyper-rec phenotype of the rem1-2 mutation was dependent upon meiotic recombination functions, we constructed two diploids that were heterozygous for rem1-2 and spoll-1. Dissection of these diploids generated spores that were 88% viable (Table 3A). Analysis of the genotypes of the spores produced indicated that one-quarter of the segregants were rem1-2 spoll-1 (Table 3B). Tetrad analysis also gave no indication of linkage. To determine the mitotic recombination phenotype of the double mutant, diploids homozygous for rem1-2 and spoll-1 were constructed containing a number of heteroallelic loci and two recessive drug resistance loci (to monitor gene conversion and crossing-over, respectively; see MATERIALS and METHODS). The data in Table 4 indicate that the spoll-1 mutation does not eliminate the high levels of mitotic recombination caused by the rem1-2 mutation. The double mutant exhibits an increase in recombination frequency at some loci compared with rem1-2 alone (see DISCUSSION). These data indicate that the rem1-2 mutation stimulates recombination to about the same extent as the rem1-1 allele.

Table 3 Analysis of rem1-2/REM1 SPO11/spo11-1 diploids

## A. Viability of Spores Produced

## Tetrad Survival Patterns

No. of Diploids Analyzed	Viable : Inviable					% Viable
	4:0	3:1	2:2	1:3	0:4	
2	21	11	1	1	0	88

## B. Genotypes of Spores Produced

No. of Spores Analyzed	<u>rem1-2</u> <u>SPO11</u>	<u>REM1</u> <u>spo11-1</u>	<u>rem1-2</u> <u>spo11-1</u>	<u>REM1</u> <u>SPO11</u>
76	20	20	18	18

The diploids examined were RM94 and RM95.

Table 4 Spontaneous mitotic recombination frequencies in spoll-1 and reml diploids

		Recombination Frequency X 10 <sup>5a</sup>								
		Intragenic							Intergenic	
Diploid Genotype	No. of Cultures	<u>lys2-1</u> <u>lys2-2</u>	<u>tyr1-1</u> <u>tyr1-2</u>	<u>his7-1</u> <u>his7-1</u>	<u>ura3-1</u> <u>ura3-13</u>	<u>met13-c</u> <u>met13-d</u>	<u>trp5-c</u> <u>trp5-2</u>	<u>leu1-c</u> <u>leu1-12</u>	<u>can1</u> <sup>R</sup> <u>CAN1</u> <sup>S</sup>	<u>cyh2</u> <sup>R</sup> <u>CYH2</u> <sup>S</sup>
<u>+</u> <u>+</u>	14	0.40	0.30	0.36	0.51	4.2	3.1	3.1	22	41
<u>reml-1</u> <sup>b</sup> <u>reml-1</u>	10	3.8 (9.6)	4.0 (13)		7.5 (15)	55.1 (13)	30.4 (9.8)	44.6 (15)	160 (7.3)	
<u>reml-2</u> <u>reml-2</u>	3	8.1 (20)	4.2 (14)	8.5 (24)	10 (20)	28 (6.7)	26 (8.4)	69 (22)	180 (8.2)	320 (7.8)
<u>reml-2</u> <u>reml-2</u>	10		2.8 (9.3)	2.7 (7.5)	23 (45)	81 (19)	340 (110)	200 (65)	790 (36)	2800 (68)
<u>spoll-1</u> <u>spoll-1</u>										

81

<sup>a</sup>Values are geometric mean frequencies. The numbers within parenthesis indicate the relative increase over wild-type frequencies.

<sup>b</sup>The reml-1 recombination frequencies are taken from Golin (80).

Interactions between the rem1-2 mutation and the  
RAD50 and RAD52 loci

Because the hyper-rec effect of a rem1 mutation was not prevented by inactivating a gene (SPO11) required for meiotic recombination, we examined the effect of the rad52-1 mutation, since rad52-1 eliminates both meiotic and mitotic recombination. We found, however, that the double mutant could not be constructed (Table 5). Diploids heterozygous for rem1-2 (or rem1-1) and rad52-1 had rather poor spore viability, and no double mutants have ever been detected. We infer that rem1 rad52-1 strains are not viable.

Since the SPO11 gene product (a meiotic Rec function) was not required for rem1 strains, the lethality of the rad52 double mutant could be most easily understood in terms of the mitotic defects conferred by rad52. To distinguish between the mitotic recombination defect and mitotic repair defect caused by rad52-1, we attempted to construct rad50 rem1 strains. The RAD50 gene is in the RAD52 repair group, but rad50 mutations do not eliminate spontaneous mitotic recombination. Thus, if the rad50-1 rem1 double mutant were alive, it would suggest that the mitotic recombination defect of rad52-1 was the reason that rad52 rem1 strains were inviable. The data in Table 6 indicate that the rad50 rem1 double mutant combination is lethal. We infer from this that it is the repair defect in the RAD52 epistasis group, or repair pathway, that causes the inviability of

Table 5 Analysis of rem1/REM1 RAD52/rad52-1 diploids

A. Viability of Spores Produced

Tetrad Survival Patterns

Diploid	Viable : Inviabile					% Viable
	4:0	3:1	2:2	1:3	0:4	
<u>rem1-1 RAD52</u> REM1 rad52-1						
MH5	6	24	9	1	0	72
MH6	0	3	7	0	0	58
MH7	4	19	12	5	0	64
MH8	2	4	2	2	0	65
Total	12	50	30	8	0	67
<u>rem1-2 RAD52</u> REM1 rad52-1						
MH3	4	25	18	2	0	66
MH9	0	3	6	1	0	55
MH10	3	11	5	1	0	70
MH11	8	22	16	2	0	69
MH12	2	2	4	1	1	58
Total	17	63	49	7	1	66

B. Genotypes of Spores Produced

Diploid Genotype	<u>rem1</u> <u>RAD52</u>	<u>REM1</u> <u>rad52-1</u>	<u>rem1</u> <u>rad52-1</u>	<u>REM1</u> <u>RAD52</u>
<u>rem1-2 RAD52</u> REM1 rad52-1	124	118	0	133
<u>rem1-1 RAD52</u> REM1 rad52-1	101	84	0	75

Diploids heterozygous for rem1 and rad52 were sporulated and dissected by micromanipulation. After 3 days, spores were examined for viability. Viable spores were tested for rem1 and rad52 as described in text.

Table 6 Analysis of rem1-2/REM1 RAD50/rad50-1 diploids

A. Viability of Spores Produced

Tetrad Survival Patterns

Diploid	Viable : Inviabile					% Viable
	4:0	3:1	2:2	1:3	0:4	
RM81	0	7	3	0	0	68
RM82	5	17	10	0	1	69
RM83	1	9	13	3	0	58
Total	6	33	26	3	1	65

B. Genotypes of Spores Produced

Viable Spore Genotype

Diploid Genotype	<u>rem1</u> <u>RAD50</u>	<u>REM1</u> <u>rad50-1</u>	<u>rem1</u> <u>rad50-1</u>	<u>REM1</u> <u>RAD50</u>
<u>rem1-2 RAD50</u> <u>REM1 rad50-1</u>	56	55	0	53

Diploids heterozygous for rem1-2 and rad50-1 were sporulated and dissected by micromanipulation. After 3 days, spores were examined to determine viability. Viable spores were picked and tested for the presence of rem1 and rad50-1 as described in Materials and Methods.



both rad50 and rad52 with rem1.

The RAD6 gene is not required for the  
hyper-rec phenotype of rem1

The RAD6 gene is not required for mitotic recombination but is essential for the repair of UV damage as well as damage by many chemical agents. Current data suggest that RAD6 acts in a different epistasis group or repair pathway than do the RAD50 and RAD52 genes (96). Therefore, we asked whether rem1-2 rad6-1 double mutants were viable (Table 7). The double mutant was clearly alive, which allowed us to ask whether it was still hyper-rec. Table 8 reveals that a rad6-1 mutation does not inhibit the hyper-rec phenotype of the rem1-2 mutation. Thus, the RAD6 pathway is neither required for viability nor recombination in rem1 strains.

The rem1 mutation does not reverse the meiotic  
defect of either spoll-1 or rad-1

The spoll-1 mutation has the meiotic phenotype of reduced sporulation and greatly reduced spore viability ( $\leq 1\%$ ) (120). The rad6-1 mutation totally eliminates sporulation (74). For both mutations it has been proposed that meiotic defect is deficiency in genetic recombination. All data for spoll-1 confirm the defect, whereas the available data for rad6-1 suggest that its primary lesion may not be in recombination (139). We wondered whether the increased recombination levels in mitosis exhibited by rem1

Table 7 Analysis of rem1-2/REM1 RAD6/rad6-1 diploids

## A. Viability of Spores Produced

## Tetrad Survival Patterns

No. of Diploids Analyzed	Viable : Inviable					% Viable
	4:0	3:1	2:2	1:3	0:4	
2	22	8	1	0	0	92

## B. Genotypes of Spores Produced

No. of Spores Analyzed	<u>rem1-2</u> <u>RAD6</u>	<u>REM1</u> <u>rad6-1</u>	<u>rem1-2</u> <u>rad6-1</u>	<u>REM1</u> <u>RAD6</u>
56	19	14	12	11

The diploids analyzed were RM92 and RM93. After sporulation and dissection, viable spores were tested for the presence of rem1-2 and rad6-1 as described in the text.

Table 8 Spontaneous mitotic recombination in rem1 rad6 double mutants

Diploid Genotype	Mean Recombination Frequency X 10 <sup>5</sup>				
	<u>ura3-1</u> ura3-13	<u>met13-c</u> met13-d	<u>trp5-c</u> trp5-2	<u>leul-c</u> leul-12	<u>can1<sup>R</sup></u> CAN1 <sup>S</sup>
<u>rem1-2 rad6-1</u> rem1-2 rad6-1	4.9 (9.6)	72 (17)	900 (290)	32 (10)	980 (45)

Mitotic recombination frequencies are the geometric mean of three cultures. The values in parentheses are the relative increase over wild type recombination frequencies. For wild type and rem1 frequencies refer to Table 4. The diploid used in this experiment was MH4.

mutant strains might allow productive sporulation in the presence of rad6-1 or spoll-1 mutations. Doubly mutant diploids were exposed to sporulation medium and examined for sporulation and spore viability (Table 9). The reml hyper-rec phenotype, even though it elevates mitotic recombination as much as 25-fold, does not overcome the meiotic defects of either mutation.

Table 9 Sporulation of rem1 spoll1 and rem1 rad6 double mutants

Diploid Genotype	No. of Diploids Examined	% Sporulation	Spores	
			% viable	No. examined
<u>rem1-2</u> <u>rem1-2</u>	5	69	82	290
<u>rad6-1</u> <u>rad6-1</u>	4	0.2	0	10
<u>spoll-1</u> <u>spoll-1</u>	2	34	0	120
<u>rem1-2 rad6-1</u> <u>rem1-2 rad6-1</u>	2	<0.2	0	3
<u>rem1-2 spoll-1</u> <u>rem1-2 spoll-1</u>	2	38	0	100

The degree of sporulation was determined by microscopic examination of at least 150 cells per diploid. Asci were then dissected, and the viability of the spores determined after 3 days. The diploids were made from segregants of intercrossoes of diploids heterozygous for rem1-2, rad6-1, or spoll-1.

## DISCUSSION

The rem1-1 and rem1-2 mutations cause increased frequencies of spontaneous mitotic recombination (a hyper-rec phenotype). One possibility for the increase in recombination is the induction of meiotic recombination functions that are not normally present (at least in high levels) during mitosis. For example, modification of an operator (or promoter) for a positive regulator of meiotic Rec functions could lead to the semidominant production of those functions during mitosis. (In this hypothesis, an ad hoc explanation of the increased mutation frequency caused by rem1 is that it would be due to the presence of unusual DNA metabolic enzymes during mitosis). Since the spoll-1 mutation did not prevent the hyper-rec phenotype of rem1, we feel that induction of the meiotic recombination system by rem1 mutations is unlikely. Of course, it is possible that meiotic functions other than SPO11 are utilized in the enhancement of recombination caused by rem1. Nonetheless, it is true that the "normal" complete meiotic recombination system cannot be responsible for the increased level of mitotic recombination conferred by rem1.

An alternative explanation of the rem1 hyper-rec phenotype is that DNA lesions are created that cause induction of repair "system(s)." When these repair systems act on the lesions, they lead to production of recombinants. (The hypermutable phenotype of rem1 mutations would then be

explainable by simply assuming that the lesions were also mutagenic.) There are at least three repair systems, pathways or "epistasis groups" in yeast; several of these pathways apparently overlap, and no clear scheme has emerged that allows all of the repair mutants to be unambiguously classified. However, most mutants can be placed into three categories as discussed in the introduction of this paper. We have utilized repair mutants that fall into two of these categories. The RAD50 and RAD52 genes are in the "double-strand break" repair pathway, whereas the RAD6 gene is in the error-prone repair pathway (96). It is reasonable to assume that double-strand breaks are repaired via a recombination-repair mechanism. Recently, Szostak et al. (239) have proposed a model for yeast recombination that incorporates a double-stranded break as central intermediate. Although their model addressed the properties of meiotic recombination, it was motivated by data obtained from mitotic studies of plasmids containing double-strand breaks. It should be noted that cells that have been transformed with plasmid DNA containing double-stranded breaks may utilize recombination processes resembling those in cells containing chromosomal double-strand breaks caused by radiation.

The inviability of rem1 rad50-1 and rem1 rad52-1 double mutants strongly indicates that the RAD52 "pathway" is indispensable in the presence of rem1 mutations. If this pathway is one that acts by a recombinational mechanism,

this is consistent with the hyper-rec phenotype of rem1 and lends credence to the contention that rem1 mutants are associated with repair and are essential. This is similar to the observations made in E. coli for lig, polA, and dam mutations (7,123,151). It is interesting that, although both RAD50 and RAD52 are required for X-ray repair, RAD50 is not necessary for spontaneous mitotic recombination. This suggests that the putative recombination event that takes place in recombination-repair may not be equivalent to "normal" spontaneous mitotic recombination. Consistent with this idea is the observation that RAD50 is required for induced mitotic recombination (216). It is tempting to speculate that the difference between X-ray recombination-repair and normal spontaneous mitotic recombination may be the difference between recombination initiated by double-strand breaks caused by X-rays and recombination initiated by other means such as single-strand nicks or unbroken homologous strand invasion (24,156,172). If the requirement in rem1 mutant strains for the RAD52 repair pathway were due to the creation of double-strand breaks, then DNA from rem1 strains should have a smaller average molecular weight than wild-type DNA. We are currently analyzing DNA from rem1 mutants with a variety of physical techniques.

A third hypothesis to explain the effect of rem1 mutations on recombination is that it leads to the induction of a completely new recombination system. A precedent for



this kind of event exists in E. coli, in which the sbcA and sbcB mutations create new recombination pathways (30). We feel that this third possibility is less likely, because strains containing a rem1 mutation do require RAD50, RAD52 and presumably the entire recombination-repair pathway. Additionally, rem1 provided no help to spoll-1 cells in meiosis; if rem1 turned on a new Rec pathway, it might well supplement the recombination defect in spoll-1 cells.

The data in Table 3 indicate that more mitotic recombination occurs in a rem1 spoll diploid than in the presence of rem1 alone. Note that, with the exception of the tyr1 and his7 loci, all other loci exhibit frequencies two- to tenfold higher in the double mutant. Klapholz and Esposito (120) have found that spoll-1 has little or no effect on mitotic recombination. Bruschi and Esposito (16) suggest that spoll-1 may specifically increase mitotic crossing over but not intragenic recombination. Although it is unclear whether the rem1 and spoll mutations are acting synergistically, it is clear that double-mutant strains do exhibit a hyper-rec phenotype. Thus, the SPOLL function, which is required for meiotic recombination to occur, is not necessary for the hyper-rec phenotype of rem1 (Table 4).

Although the hyper-rec phenotype exhibited by the rad6-1 rem1-2 double mutant is consistent with the meiotic recombination system not being induced by rem1 mutations, it does not provide strong support for this conclusion. Al-

though Game *et al.* (74) suggested that RAD6 was required for meiotic recombination, subsequent evidence indicates that it may be required for some other aspect of meiosis (139). The viability of the rad6-1 rem1-2 double mutant gives us the opportunity to test whether the hyper-mutability of rem1 strains is dependent upon the RAD6 error-prone repair system. We are testing this by analyzing mutation rates in the double mutant.

In conclusion, we feel that mutating the REM1 locus in yeast leads to the expression of a new or altered function(s) that, in turn, may lead to lesions in the DNA. We propose that these lesions lead to breaks in the DNA that, if not repaired by the RAD52 recombination-repair pathway, cause the cells to die. The semidominance of the two rem1 mutant alleles would occur if the mutant allele positively controls a "new" function that leads to lesions. Alternatively, it could be due to a mutant enzymatic function that can compete with the wild-type product in rem1/REM1 heterozygotes. Finally, the REM1 gene product may be a component of a multienzyme complex. The rem1 product and complexes containing REM1 product could compete equally well. The ability of a single mutation to be semidominant, mutagenic and recombinogenic has significant portents for a number of interesting problems in higher eukaryotic systems. Perhaps one of the most relevant is the relationship between mutagenesis and carcinogenesis in mammalian systems. A single

event creating a mutation such as rem1 would allow not only an increased frequency of mutations (most of which are recessive) but would also cause them to become homozygosed by mitotic recombination.

## CHAPTER III

### HYPER-MUTATION CAUSED BY THE rem1 MUTATION IN YEAST IS NOT DEPENDENT ON THE ERROR-PRONE OR EXCISION-REPAIR GROUPS<sup>2</sup>

#### ABSTRACT

Mutations in the REM1 gene of Saccharomyces cerevisiae confer a semi-dominant hyper-rec/hyper-mutable phenotype. Neither rem1 mutant allele has any apparent meiotic affect. We have examined spontaneous mutation in rem1-2 strains and demonstrate that the rem1-2 mutation, like rem1-1, confers an approximate 10 fold increase in mutation rates for reversion and forward mutations. Unlike certain yeast rad mutations with phenotypes somewhat similar to rem1, strains containing rem1 are resistant to MMS and only slightly UV sensitive at very high doses. Also, rem1 mutant strains are less inducible for forward mutation to canavanine-resistance. To understand the mutator phenotype of rem1, we have used a double mutant approach, combining the rem1 mutation with radiation-sensitive mutations affecting DNA repair. Double mutants of rem1-2 and a mutation in the yeast error-prone repair group (rad6-1) or a mutation in excision-repair

<sup>2</sup> M. F. Hoekstra and R. E. Malone, (1986). Mutation Research (in preparation).

(rad1-2 or rad4) maintain the hyper-mutable phenotype. We have interpreted these results in terms of a channelling model for recombination and mutation. Since mutation rates remain elevated in double mutant strains, it appears as if the effect of rem1 on mutation mimics spontaneous mutation in not requiring the action of a repair system.

## INTRODUCTION

The understanding of DNA metabolism in prokaryotes has been aided by the isolation and characterization of mutations demonstrating abnormal phenotypes with respect to radiation and chemical sensitivity. For example, in Escherichia coli, mutations in genes coding for functions involved in recombination or DNA repair, such as recA, recB/C, and the uvrA, B, C, D series, are sensitive to UV irradiation and/or genotoxic chemicals (31,215,217). Often, the mutations confer altered levels of spontaneous recombination and mutation (reviewed in 249). We have employed the baker's and brewer's yeast, Saccharomyces cerevisiae, as a eukaryotic model system for studying DNA metabolism as it relates to genetic recombination and DNA repair. Yeast cells exhibit the same genetic properties as more complex eukaryotes, but are more amenable to basic genetic analysis.

The process of mutation in S. cerevisiae occurs by at least two different pathways. In responding to environmental insults such as UV damage or certain genotoxic chemicals, the cell can employ an "error-prone" repair process requiring, among others, the RAD6 gene (71,96,184, 244). The repair of damaged DNA by the error-prone system leads to an increased frequency of mutations in survivors. Yeast have other, presumably error-free, repair pathways including photoreactivation (192,243), excision-repair (202,203) and recombination-repair (74,140). This latter

pathway has also been called double-strand break repair (96,171). Unlike the error-prone (recA/lexA dependent) SOS repair system in E. coli (249), the mechanism by which induced mutations occur via error-prone repair in yeast is not yet understood. With the exception of photoreactivation, yeast repair "pathways" are not rigidly defined (70, 94). Certain repair gene products may act in more than one pathway, and the pathways themselves may share common branches.

Mutations can also occur spontaneously in yeast. Since spontaneous mutations occur at similar frequencies in strains with RAD6 and with rad6 (this work and reference 92), this class of mutations does not appear to depend on error-prone repair. It is reasonable to assume that a primary source of spontaneous mutations in yeast is unrepaired replication errors; such errors (base mismatches) need not be acted upon by an error-prone system to become mutations (244). Only replication is required to fix them. It is possible, however, that some replication errors are normally corrected by one of the error-free systems. Thus, certain repair mutations, involved in recombination-repair or excision-repair, can lead to an increased spontaneous mutation rate (18, 161). To account for increased mutation rates in recombination-repair deficient strains, it has been proposed that replication errors and other spontaneous damages are channelled into the error-prone repair process

when the normal error-free pathways are inactivated (92, 106,186,244).

In 1977, Golin and Esposito described the isolation of rem1-1 (80). This mutation was isolated on the basis of a mutator property and subsequently shown to confer a hyper-recombinogenic phenotype. We have previously described the isolation of a second REM1 mutation, rem1-2, that confers a mitosis-specific, semidominant hyper-rec phenotype (144). Strains with rem1 mutations have no apparent meiotic defect. During the initial characterization of the hyper-rec rem1 phenotype, we observed that double mutant strains containing rem1 and mutations in the yeast recombination-repair group were inviable (144). Specifically, rem1-2 rad50-1 and rem1-2 rad52-1 double mutant spores do not form colonies. This phenomenon is not due to allele specific interactions; combinations like rem1-1 rad52-1, rem1-2 rad50-3, and rem1-2 rad50-4-4 are also inviable (M. F. H. and R. E. M., unpublished observations and reference 144). On the basis of this data, we have proposed that rem1 strains contain recombinogenic DNA lesions requiring recombination-repair for viability (144). In other words, in the presence of a rem1 mutation, recombination-repair appears to be essential.

In this report we describe the characterization of spontaneous mutation in rem1-2 strains. Unlike certain yeast rad mutations with hyper-rec and/or mutator pheno-



types, we demonstrate that rem1 strains are as resistant as wild type to Methyl-methane-sulfonate (MMS) and are only slightly UV sensitive (at high doses). We also present a characterization of interactions between rem1-2 and mutations in excision-repair and error-prone repair. We analyzed the phenotypes of rem1-containing double mutants with respect to spontaneous mutation levels (e.g., rem1-2 rad1-2, rem1-2 rad4 and rem1-2 rad6-1). From the data presented, we propose that mutations occurring in rem1 strains are formally similar to spontaneous mutations in that they can occur without requiring the action of repair systems.

## MATERIALS AND METHODS

### Strains and growth conditions

The strains used in this report are listed in table 10. Strain constructions involved standard procedures for crosses, propagation and dissection (144). The rad1-2 mutation originated from DH25 - 1D (kindly supplied by Dr. L. Prakash, University of Rochester). The rad4 mutation was obtained from the Yeast Genetic Stock Center (Berkeley, CA). These mutations were introduced into our strains by at least four backcrosses with wild type laboratory strains. Growth conditions and media recipes are as described by Golin and Esposito (80) and Malone and Hoekstra (144).

### UV and MMS treatment

UV survival kinetics were performed by exposing cells to a constant dose of UV light for an increasing period of time and measuring viability at various times. The UV light source was two Germicidal lamps (GE model G15T8, 15 watt) and UV fluence levels were measured by a UVX digital radiometer (Ultraviolet Products, Inc.). After exposure to the UV source, the plated cells were immediately wrapped in aluminum foil in the dark and grown at 30°C for 3 days. This precaution was taken to avoid photoreactivation of the UV-produced lesions. MMS resistance was determined as described by Hoekstra, Naughton and Malone (Chapter 4 and reference 106). Briefly, cells were grown in YPD medium to

Table 10 Strains

---

strain	Relevant Genotype
K210-4A	$\alpha$ <u>his7-2 met13-d CYH2<sup>S</sup> trp5-2 leu1-12</u>
K210-6D	a <u>his7-2 met13-d CYH2<sup>S</sup> trp5-2 leu1-12</u>
K264-5B	$\alpha$ <u>his7-1 lys2-2 ura3-1 CAN1<sup>S</sup> leu1-c</u>
K264-10D	a <u>his7-1 lys2-2 ura3-1 CAN1<sup>S</sup> leu1-c</u>
MH85-9A	$\alpha$ <u>rad1-2 his7-2 leu1-12</u>
MH86-7A	a <u>rad1-2 his7-2 leu1-c</u>
MH78-8D	$\alpha$ <u>rad4 his7-1 leu1-c</u>
MH90-3D	$\alpha$ <u>rad4 his7-1 leu1-c</u>
RM97-2D	a <u>rad6-1 his7-2 met13-d CYH2<sup>S</sup> trp5-2 leu1-12</u>
RM97-9A	$\alpha$ <u>rad6-1 his7-2 met13-d CYH2<sup>S</sup> trp5-2 leu1-12</u>
RM115-5C	$\alpha$ <u>rad6-1 his7-1 lys2-2 ura3-1 CAN1<sup>S</sup> leu1-c</u>
RM115-19A	a <u>rad6-1 his7-1 lys2-2 ura3-1 CAN1<sup>S</sup> leu1-c</u>
MH84-5C	$\alpha$ <u>rem1-2 CAN1 met13-d CYH2<sup>S</sup> trp5-2 leu1-c</u>
MH84-21B	$\alpha$ <u>rem1-2 lys2-2 ura3-1 CYH2<sup>S</sup> leu1-c</u>
MH84-24A	a <u>rem1-2 his7-2 CAN1<sup>S</sup> met13-d CYH2<sup>S</sup> trp5-2</u> <u>leu1-c</u>
MH84-26A	a <u>rem1-2 lys2-2 ura3-1 CAN1<sup>S</sup> CYH2<sup>S</sup> leu1-c</u>
MH89-11D	a <u>rem1-2 his7-2 leu1-12</u>
MH90-12D	$\alpha$ <u>rem1-2 his7-1 leu1-c</u>
MH87-6D	a <u>rem1-2 rad1-2 his7-2 leu1-c</u>
MH88-2D	a <u>rem1-2 rad1-2 his7-1 leu1-12</u>
MH90-17D	a <u>rem1-2 rad4 his7-1 leu1-c</u>

---

Table 10 (Continued)

---

Strain	Relevant Genotype
RM116-4B	<u>a</u> <u>rem1-2</u> <u>rad6-1</u> <u>his7-2</u> <u>met13-d</u> <u>CYH2<sup>S</sup></u> <u>trp5-2</u> <u>leu1-12</u>
RM116-1A	<u>α</u> <u>rem1-2</u> <u>rad6-1</u> <u>his7-2</u> <u>met13-d</u> <u>CYH2<sup>S</sup></u> <u>trp5-2</u> <u>leu1-12</u>
RM117-8C	<u>a</u> <u>rem1-2</u> <u>rad6-1</u> <u>lys2-2</u> <u>ura3-1</u> <u>CAN1<sup>S</sup></u> <u>leu1-c</u>
RM117-7B	<u>α</u> <u>rem1-2</u> <u>rad6-1</u> <u>lys2-2</u> <u>ura3-1</u> <u>CAN1<sup>S</sup></u> <u>leu1-c</u>

---

mid-logarithmic phase, washed twice with and resuspended in 5 ml of 0.2 M sodium phosphate buffer (pH 7.5). To this, 50 microliters of MMS (Eastman Kodak) was added and survival assayed at various times following addition. MMS was inactivated by diluting and holding cells in sterile 5%  $\text{Na}_2\text{S}_2\text{O}_3$  for 5 minutes before plating on appropriate media. UV and MMS survival kinetics were measured at least three times.

#### Determination of spontaneous mutation rates

In preliminary experiments, the frequency of spontaneous mutation was determined as described by Hoekstra and Malone (Chapter 6 and reference 103) and Hoekstra, Naughton and Malone (Chapter 5 and reference 106). Precise mutation rates were determined by the method of Luria and Delbruck (137) as modified by Fogel and co-workers (59,146). Yeast strains were plated for single colonies on YPD medium and grown for 3 - 4 days at 30°C until large, well-isolated colonies were present. Colonies were removed from the Petri dish by excising a small agar block around the colony. The colony was washed off the agar in a small volume of buffer (approximately 0.2 ml) and the entire colony plated on appropriate medium. To determine the average number of cells per colony, ten isolated colonies were analyzed by the above regimen and appropriate dilutions plated on synthetic complete medium. The number of cells in a colony ranged from  $5 \times 10^6$  to  $2 \times 10^7$ . From microscopic observation, we

estimate that greater than 99% of the cells are removed from the agar block in the wash. Data in Table 12 was determined by the traditional method of growing a number of independent liquid cultures (137). To determine the mutation rate, the equation  $P(o) = e^{-m}$  was used.  $P(o)$  is the fraction of cultures showing no mutation and "m" is the average number of mutations. The mutation rate is determined from  $m/(N_t - N_o)$ , where  $N_t$  and  $N_o$  are the number of yeast in a culture at times t and o.

## RESULTS

### The effect of the rem1-2 allele on spontaneous mutation

Since the rem1-1 mutation has been shown to be a mutator (80), we wanted to verify that the rem1-2 allele also conferred this phenotype. Tables 11 and 12 demonstrate that spontaneous mutation levels are increased in rem1-2 strains and that the increase can be as much as ten-fold greater than wild type. Mutation is increased in rem1-2 cells whether it is measured by frequencies or rates calculated by the method of Luria and Delbruck (137). The auxotrophic mutation lys2-2 is an ochre mutation, hence prototrophs can represent revertants or forward mutations at tRNA loci. Resistance to canavanine or cycloheximide also represent forward mutations. Thus, rem1-2 increases mutation rates on all chromosomes at all loci examined for both forward and reverse mutation. These results are similar to the 6 and 15 fold stimulation of mutation at CAN1 and trp5-2 for rem1-1 strains (79,80).

### Increased mutation in rem1-2 strains is not dependent on error-prone or excision-repair groups

To determine if mutations occurring in rem1-2 strains require the action of repair pathways, the level of spontaneous mutation in double mutant strains was measured. The data presented in table 11 suggest that RAD6 is not required for the increase in mutation caused by the rem1-2 mutation.

Table 11 Frequency of spontaneous mutation in haploid strains

Genotype	No. of Cultures	Prototroph and Drug-Resistance (X10 <sup>8</sup> )								
		<u>his7-2</u>	<u>ura3-1</u>	<u>met13-d</u>	<u>trp5-2</u>	<u>leul-12</u>	<u>leul-c</u>	<u>lys2-2</u>	<u>CAN1</u>	<u>CYH2</u>
<u>±</u>	4	1.6	<0.8	<0.9	<0.5	<0.9	<1.3	96.2	108	<6.7
<u>rad6-1</u>	4	<3.2	<0.9	<1.6	<3.2	<3.5	<2.6	44.9	50.9	3.2
<u>rem1-2</u>	6	32.0	5.9	3.0	4.7	4.4	13.0	175	545	11.2
<u>rem1-2 rad6-1</u>	4	14.4	2.8	5.5	3.0	7.6	29.5	140	725	18.3

Mutation frequencies were determined as described in Materials and Methods and Hoekstra, Naughton, and Malone (106). Values with a less-than symbol indicate that at least one of the cultures showed no mutants. In those cultures where no mutants arose, we have calculated an estimated frequency based on the appearance of 1 colony. Therefore, the values in the table with "<" represent an overestimate. The lys2-2 allele is suppressible and therefore represents both forward and reverse mutations. The values at CAN1 and CYH2 represent measurements of forward mutation to drug<sup>R</sup>.



Table 12 Mutation rates in haploid strains determined from multiple liquid cultures

GENOTYPE	MUTATION RATE (X 10 <sup>8</sup> )		
	his7-2	leu1-c	CAN1
Wild type	1.08	0.87	370
<u>rad6-1</u>	3.36	1.19	350
<u>rem1-2</u>	13.7	10.6	1900
<u>rem1-2 rad6-1</u>	31.3	39.8	910

Mutation rates were determined by growing multiple cultures, inoculated at low concentration (approximately 25 cells/ml), to stationary phase, washing the cells, and plating the entire contents on the appropriate medium. Three parallel cultures were grown to determine average cell titre. The cell titre appeared strain specific and ranged from approximately  $5 \times 10^7$  cells/ml for rad6-1-containing strains to  $1.5 \times 10^8$  cells/ml for wild-type and rem1 strains. The results presented represent 36 cultures per strain per medium. The mutation rates were calculated using the P(o) method of Luria and Delbruck (135).

We also note that rad6-1 strains alone had wild type (or perhaps slightly elevated) levels of spontaneous mutation. This argues that RAD6 plays no role in spontaneous mutation. If RAD6 did act in an error-prone fashion to contribute to spontaneous mutation, then removing it should lead to reduced mutation levels. This is clearly not the case and suggests that most spontaneous mutation is not dependent upon error-prone repair. This conclusion is supported by the data obtained from P(o) measurements of mutation rates in rem1-2 rad6-1 double mutants (Tables 12 and 13). The effect of excision-repair mutations (rad1-2 and rad4) on mutability are shown in Table 13. Both reversion and forward mutation rates, measured at a number of loci, are elevated in rem1-2 rad1-2 and rem1-2 rad4 double mutants. Interestingly, we do not observe increased mutation rates in rad1 and rad4 mutants. In other words, damages do not appear to be shifted to the RAD6 pathway. Comparisons of the mutation levels in rem1-2 rad double mutants versus the rad single mutant control background levels shows that the relative increase is similar to the increase in rem1-2 versus wild type. We do note that the rem1 rad1 and rem1 rad4 double mutants are not as hyper-mutable as rem1 alone. However, these strains are elevated 7 and 5 fold above the rad1 and rad4 backgrounds. Therefore, mutations found in rem1-2 strains of S. cerevisiae are similar to spontaneous lesions found in wild type cells in that the action of

Table 13 Reversion rates in various strains

GENOTYPE	MUTATION RATE (X 10 <sup>8</sup> )			RATIO <sup>a</sup>
	his7-1	his7-2	leul-c	
Wild type	0.09	1.3	0.32	1.0
<u>rad1-2</u>	---	<0.08	0.46	0.7
<u>rad4</u>	0.10	---	0.20	0.9
<u>rad6-1</u>	---	1.1	0.39	1.0
<u>rem1-2</u>	0.56	8.0	4.8	9.2
<u>rem1-2 rad1-2</u>	---	3.0	2.8	5.5
<u>rem1-2 rad4</u>	0.53	---	0.72	4.1
<u>rem1-2 rad6-1</u>	---	6.0	6.8	13

The mutation rate was determined by the agar-block method, which is distinct from the traditional liquid culture method (see Materials and Methods). Rates were calculated by the P(o) method of Luria and Delbruck (135) from 52 cultures. The number of cells in a colony ranged from  $5 \times 10^6$  to  $2 \times 10^7$ .

<sup>a</sup>RATIO refers to the relative mutation rate for a given locus, compared to wild type and averaged for all loci examined within a given strain.

repair systems is not required for their occurrence. We note that in every case but one, the mutation rates determined from liquid culture experiments are slightly higher than those determined by the agar block method. The reason for this difference is unclear, however, in all cases the trends are identical.

Because all recombination studies have necessarily been performed in MAT $\alpha$ /MAT $\alpha$  diploids, we examined mutation levels in cultures of diploids. As expected, for reversion at leul-c, homozygous rem1-2 and rem1-2 rad6-1 diploids exhibit essentially the same properties as haploids (Table 14). Thus, the recombination (143) and mutation effects of rem1 have been analyzed in the same cell type.

#### Radiation and chemical sensitivity of the rem1-2 allele

Unlike rad mutations with hyper-rec phenotypes (eg. rad6-1 and rad50-1), rem1 strains are MMS and UV resistant (Figure 6). Included as controls for MMS survival are a wild type strain closely related to the rem1-2 strain (a sister strain from the same tetrad) and a rad52-1 strain of similar genetic background. The rad52-1 mutation confers a high level of MMS sensitivity (182). As shown in Figure 6A, rem1-2 strains are as resistant as wild type to the radio-mimetic monofunctional alkylating agent MMS. Figure 6B shows the UV survival kinetics for rem1-2. Controls included on this figure are wild type and rad6-1 strains. The rad6-1 mutation, as discussed, is defective in error-prone

Table 14 Reversion frequency at leu1-c in diploid strains

DIPLOID GENOTYPE	<u>+</u> +	<u>rad6-1</u> rad6-1	<u>rem1-2</u> rem1-2	<u>rem1-2 rad6-1</u> rem1-2 rad6-1
REVERSION FREQUENCY (X 108)	1.09	2.03	108	183

Reversion frequencies were determined as described in Materials and Methods. The strains used in this experiment were intercroses of haploids presented in Table 10. Results represent geometric mean reversion frequencies from triplicate measurements.

Figure 6 Survival curves for rem1-containing strains. Procedures for kill curves are described in Materials and Methods. Strains used were haploids listed in Table 10. The wild-type and rem1-2 survival curves following MMS treatment (A) represent triplicate measurements. The UV survival curves (B) represent the average of four independent measurements. All experiments were performed using highly related sister segregants from a heterozygous REM1/rem1 diploid.

A. MMS Survival

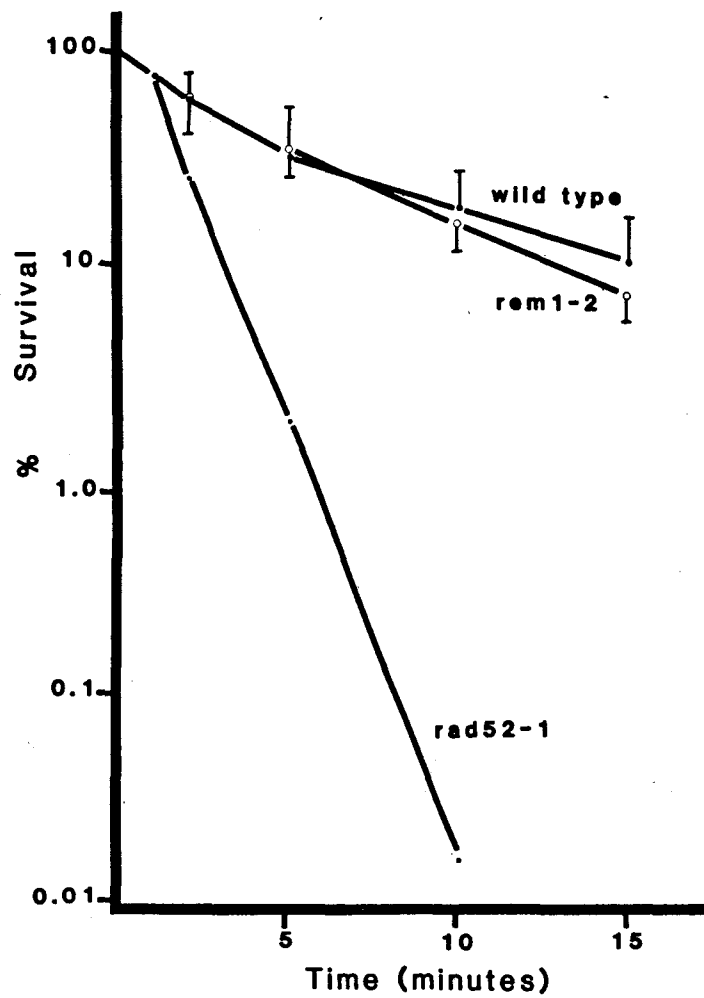

B. UV Survival

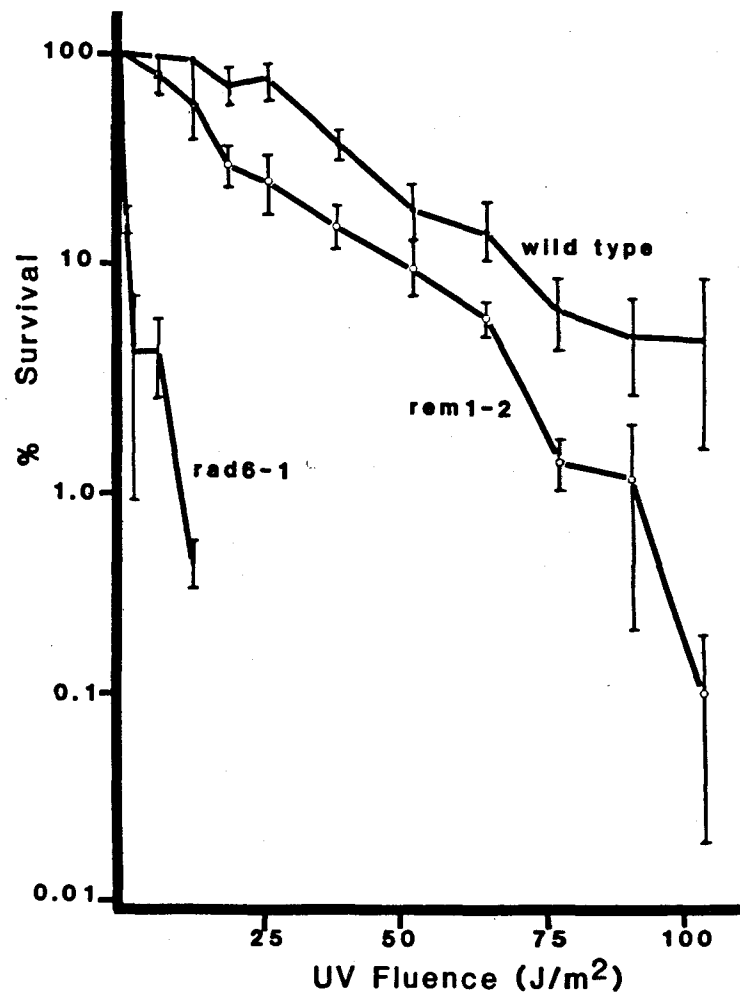

(inducible) repair and is UV, X-ray and chemical sensitive (96). At low UV fluence levels, rem1-2 is as resistant as wild type to UV irradiation. At very high UV doses, rem1-2 begins to demonstrate modest UV sensitivity. However, in no way does the slight sensitivity at high UV levels match the UV sensitivity of rad6-1 or rad1-2, rad3-2, and rad4 excision-repair mutations (Chapters 4 and 8). We have found that for comparable doses, rem1-2 is at least 2 - 3 orders of magnitude more resistant to UV than these excision-repair mutations.

#### Induced mutation in rem1-2 strains

To determine the extent that mutation could be induced in rem1 strains, we measured forward mutation to canavanine resistance. The canavanine-resistance mutation frequency as a function of MMS exposure, relative to the untreated sample, is plotted in Figure 7. The inset represents the actual mutation frequencies observed at a given MMS dosage. The wild type demonstrates a maximum 17.5 fold increase in forward mutation when treated with MMS ( $2.4 \times 10^{-6}$  versus  $4.2 \times 10^{-5}$ ), but rem1-2 shows only a 3 fold increase in mutation ( $1.1 \times 10^{-5}$  versus  $3.2 \times 10^{-5}$ ) at the corresponding maximum. It is interesting that the actual frequencies reached at maximum by rem1-2 and wild type cells are similar. W. Seide and F. Ekhardt (personal communication) have examined UV-induced mutation in rem1-2 strains. For wild type cells, a linear-quadratic biphasic induction curve



Figure 7 Relative forward mutation levels in rem1 strains following MMS treatment. The frequency of canavanine-resistant cells was determined at various times following MMS addition. Values presented for a given dose are relative to the untreated sample. The frequencies represent the geometric mean mutation frequency from three experiments. For both REM1 and rem1-2, the standard deviations at all times of measurement was less than 5% of the values shown.

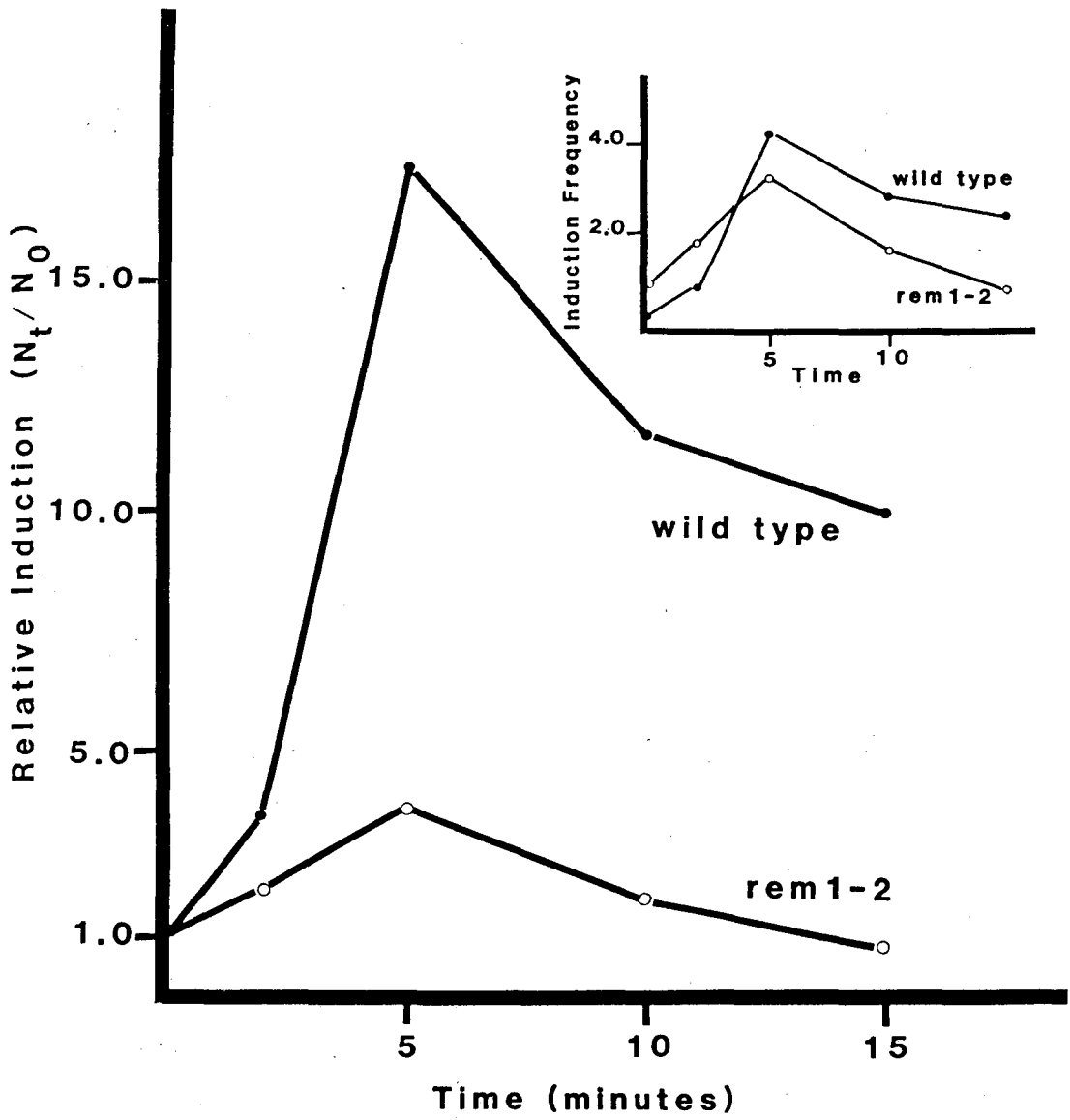

is normally observed with a plot of log mutation frequency versus log dose. The historic interpretation of wild type kinetics is that the linear portion of the curve represents constitutive levels of the mutational process while the quadratic portion is due to an inducible component of the mutational process (40,95). Seide and Ekhardt have found that induced reversion in rem1-2 strains following low UV doses, follows only linear kinetics. This is similar to observations for UV-induced mutation in excision-repair defective strains. These results, taken together with the MMS induction kinetics, suggest that the inducible component for mutation may be defective in rem1-2 strains.

## Discussion

Mutations in the reml gene of yeast lead to increased levels of spontaneous mitotic recombination and mutation. The reml-increased recombination may be essential because strains containing reml and a mutation in genes needed for recombination-repair are inviable. Cells which contain reml and a mutation in error-prone repair (rad6-1) or excision-repair (rad1-2 and rad4), however, are viable.

Von Borstel and co-workers, and others, have proposed a "channelling" mechanism for the generation of induced mutations (71,92,244). They proposed that when an induced DNA lesion occurs, alternative repair systems can recognize and respond to the lesion. Depending upon the lesion and mode of repair, a recombination event or mutation can occur. For example, following UV treatment, mitotic recombination is increased as some UV damage is channelled through the recombination-repair group. If the cyclobutyl dimer is acted upon by excision-repair functions, the lesion can be channelled through this repair group and corrected in an error-free fashion. If acted upon by the RAD6 error-prone group the result can be a mutation. We have considered the cellular responses to reml-created DNA lesions in terms of the "channelling" hypothesis.

A channelling model for the reml-created DNA lesion is given in Figure 8. If reml mutations result in DNA lesions (X) which can be repaired by either recombination-repair

Figure 8 Channelling model as applied to rem1. Salient points for the construction of the model are presented in the text.

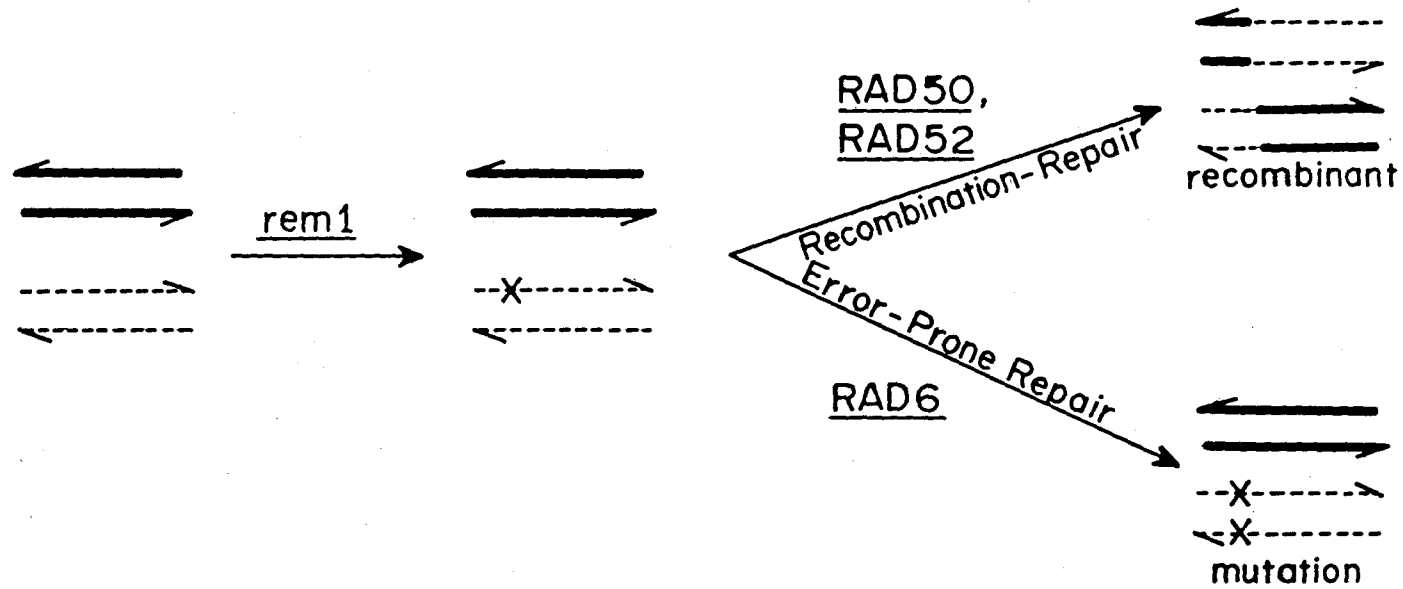

(which would lead to increased mitotic recombination), by error-prone repair (which would lead to increased mutation), or by excision-repair (which would result in neither mutation or recombination), then rem1 rad6 double mutants should display two phenotypes. They should show even higher levels of mitotic recombination than rem1 alone and rad6 (almost normal) levels of spontaneous mutation. We have previously shown that rem1-2 rad6-1 double mutants have rem1 levels of spontaneous mitotic gene conversion and crossing-over (143). The data presented here indicate that rem1-2 rad6-1 strains have increased mutation levels similar to rem1-2 alone. Mutations in RAD6 do not lead to a reduction in the hyper-mutable effect of rem1. The scheme, as shown, can account for the inviability of rem1 rad52 and rem1 rad50 double mutants (143) by requiring rem1 hyper-recombinogenic lesion to proceed through the RAD52 recombination-repair group. However, the independence of rem1 hyper-mutation from RAD6 (and presumably the error-prone repair pathway) is inconsistent with this model.

A revised hypothesis for the rem1-created DNA lesion still presumes that a single form of lesion occurs in rem1 strains and, like the channelling model, it has alternative fates. This modified channelling model, as applied to rem1, is given in Figure 9. If unrecognized, the lesion directly leads to a mutation. No repair system need act on it. If recognized, the lesion ultimately results in a double-strand

Figure 9 Modified channelling model for the action of rem1.

The construction of the model is described in the text.



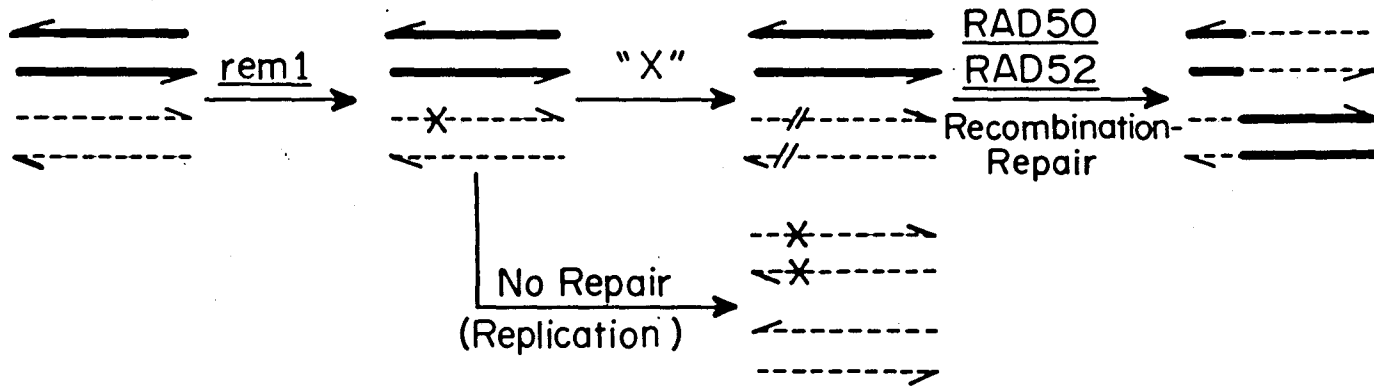

break. In other words, there should be a cellular function(s) which acts upon rem1 damage to create the recombinogenic lesions. We have found that excision-repair functions in yeast (e.g. rad1 and rad4) appear capable of recognizing the rem1 lesion and result in its conversion to a double-strand break (Chapter 4). The revised model accounts not only for the rem1 rad50 and rem1 rad52 double mutant inviability, but for rem1 hyper-recombination (by processing the lesion through recombination-repair) and the independence of rem1 mutability from rad6-1. We have examined spontaneous mutation in rem1-containing, excision-repair deficient strains and have demonstrated that mutation rates are elevated above the rad1-2 and rad4 single mutant controls. These data are consistent with the scheme presented above; the excision-repair products are not required for the increase in mutation caused by rem1. We conclude neither excision-repair nor error-prone repair are involved in the hyper-mutation phenotype of rem1. We note, however, with regards to the proposed cellular function(s) acting on the rem1 damage, that a mutated "X" could rescue rem1 rad50 and rem1 rad52 double mutant inviability. A mutation of this sort could prevent the formation of a recombinogenic intermediate.

An alternative hypothesis for the nature of the rem1-created DNA lesion is a direct double-strand break. This would account for the dependence upon recombination-repair,

but not for the increased mutation frequency in rem1 strains. It is also difficult to conceive how a double-strand break could lead to mutations because the recombination-repair pathway in yeast is likely an error-free system (61,71,96). Also, if the rem1 mutation leads to a direct double-strand break, triple mutants like rem1 rad1 rad52 should be inviable. Thus, unless rem1 damage causes recombination-repair to be mutagenic, we feel it unlikely that rem1 leads directly to DNA double-strand breaks.

What might the rem1 DNA lesion be? One obvious possibility is a base mismatch. The presence of the rem1 mutation might increase the occurrence of replication errors, resulting in more mismatched bases. If unrecognized, these would result in mutations. In both mitosis and meiosis, gene conversion appears to involve the correction of base mismatches. It has recently been demonstrated that yeast cells contain a mitotic mismatch repair system (D. Bishop and R. Kolodner, personal communication). Also, mutants (pms) have been isolated which have increased frequencies of meiotic gene conversion and mitotic mutation and demonstrate a decreased ratio of 6:2 and 2:6/5:3 and 3:5 classes of meiotic gene conversions [characteristics predicted for a mutant defective in base mismatch repair (63,254)]. We therefore suggest that gene products exist which could recognize the putative rem1-caused mismatch. These gene products would act on the rem1-produced DNA lesion, ulti-

mately resulting in a double-strand break. The break would be repaired by the RAD52 recombination-repair system, resulting in increased recombination. If rem1 does lead to an increase in base mismatches, a possible function for the wild type REM1 product might be DNA replication. A test for the prediction of increased mismatches would be to examine rem1-2 pms1 double mutants. If removing heteroduplex correction ability, presumably via base mismatch correction, affects the outcome of the rem1 DNA lesion, a rem1 pms1 double mutant should show levels of recombination and mutation different from the rem1 hyper-recombination and hypermutation frequencies.

## CHAPTER IV

### INTERACTIONS BETWEEN RECOMBINATION AND REPAIR FUNCTIONS DURING MITOSIS IN YEAST: GENETIC ANALYSIS AND CLONING OF REM1<sup>3</sup>

#### ABSTRACT

The rem1 mutations in yeast are semi-dominant mutations that cause an increase in mutation and recombination levels during mitosis. We have examined the interactions between the rem1 mutant alleles and various radiation-sensitive mutations to gain an understanding of the cause of the hyper-rec/hyper-mutable phenotype. We have found that: (i) double mutants of rem1 and mutations in double-strand break repair are inviable; (ii) rem1 strains with mutations in excision-repair exhibit a specific reduction in mitotic gene conversion; (iii) triple mutants, defective in double-strand break repair and excision-repair, and containing rem1 are viable, have altered gene conversion levels, but demonstrate crossing-over levels greater than rem1 alone. We have interpreted these observations in a model to explain the effect of the rem1 mutation. Consistent with the predictions of the model, we find that the

<sup>3</sup> M. F. Hoekstra and R. E. Malone, 1986. Cell (in preparation)

size of DNA from rem1 strains, as measured by neutral sucrose gradients, is slightly smaller than wild type. We also have cloned the REM1 gene. The clone complements all rem1 mutant phenotypes tested. As expected from genetic mapping, the cloned REM1 complements the rad3-2 mutation for UV-sensitivity and hybridizes to an internal fragment from a verified RAD3 clone. An authenticated RAD3 clone also complements for rem1 hyper-recombination. On this basis we feel rem1 mutations are alleles of the essential mitotic function RAD3.

## INTRODUCTION

Genetic recombination is a ubiquitous process; it has been observed in almost every organism examined. Recombination is essential in most organisms for meiosis to occur. The meiotic hallmark of homologous pairing during reductional division is believed to require recombination (6). Generally, without recombination, homologous pairing is not facilitated and the cell undergoing meiosis does not generate viable products (74,186).

This is not to say that recombination is restricted to meiosis, mitotic recombination can and does occur (128). Recently, experimental molecular models for mitotic recombination in higher eukaryotic cells have been described. Many of these experiments describe the recombination that occurs between artificial substrates [ie. plasmids (37,135, 226)]. The results of these experiments have shown that tissue culture cells are capable of supporting homologous and non-homologous recombination between the introduced molecules. Also, interest in mitotic recombination has been stimulated, in part, by the observation that many mutagenic and carcinogenic treatments are also recombinogenic (96). From this observation, one can speculate that spontaneous mitotic recombination may simply be a reflection of the cell's response to spontaneous chromosomal lesions.

In this communication, we examine the properties of spontaneous mitotic recombination using natural substrates

-- chromosomes. The model system we have employed is the baker's and brewer's yeast Saccharomyces cerevisiae. In yeast, like most eukaryotes, mitotic recombination is a relatively rare occurrence. It occurs at a frequency of approximately  $10^{-3}$  -  $10^{-6}$ , and for a given genetic interval the level is as much as 2 to 3 orders of magnitude lower than meiotic recombination (50). We have examined mitotic recombination in hyper-rec rem1 strains of S. cerevisiae in order to gain an understanding of the recombination phenotypes conferred by the mutation.

The rem1 mutations confer a semi-dominant, mitosis-specific, hyper-rec/hyper-mutable phenotype (80,81,143). The first allele, rem1-1, was isolated by Golin and Esposito as a mutator mutation and subsequently shown to confer an increase in spontaneous mitotic recombination (80,81). We independently isolated a second allele, rem1-2, as a hyper-rec mutation (143) and have shown it to confer a mutator phenotype (Chapter 3 and reference 105). Unlike certain rad mutations that display some of the rem1 phenotypes, strains containing rem1 are essentially as resistant as wild type cells to treatments such as UV and Methyl-methane-sulfonate (MMS) (Chapter 3 and reference 103), implying that rem1 mutations do not confer a defect in repair.

In wild-type cells, there is a meiotic centomeric compression of map intervals (142). The distribution of recombination events along a chromosome in rem1 strains is



intermediate to wild type mitotic and meiotic distributions (142). This led to a proposal that meiotic functions might be "turned-on" in rem1 strains (142,143), perhaps generating recombination structures not normally present in mitotic cells. We addressed this possibility and demonstrated, by multiple mutant analysis, that the complete meiotic recombination system was not responsible for the rem1 phenotype (143). By the same multiple mutant approach, it was shown that rem1-containing strains require the RAD50 and RAD52 functions (143). The RAD50 and RAD52 gene products are involved in double-strand break (recombination) repair (71,74,96,140,186). Double mutants of rem1 rad50 and rem1 rad52 are inviable (141). This is not an allele specific effect. Both rem1 mutations are inviable with a number of rad50 and rad52 mutant alleles. Therefore, we have proposed that lesions occur in the DNA of rem1 strains which require recombination-repair to maintain viability (143).

To examine mitotic recombination we have used a combination of genetic, physical, and molecular biological approaches. In this report we describe the analysis of interactions between rem1 and various RAD functions in yeast (the properties of the mutations used in this study are summarized in Table 15). We show that rem1-produced recombination requires excision-repair functions for the generation of a molecular intermediate resolved by double-strand break

Table 15 Phenotype of mutations used in combination with rem1

Mutation	Radiation Sensitivity	Repair <sup>b</sup> Group	Recombination		Spontaneous <sup>f</sup> Mutation	Comments
			Spontaneous <sup>d</sup> Mitotic	Meiotic <sup>e</sup>		
<u>rem1</u>	± UV <sup>a</sup>	N.C. <sup>c</sup> (ER)	+++	+	+++	Semi-dominant; Hyper-rec/mutable; Mitosis-specific
<u>rad1</u>	UV	<u>RAD3</u> ER	+	+	±	Deficient in dimer removal
<u>rad4</u>	UV	<u>RAD3</u> ER	+	+	±	Deficient in dimer removal
<u>rad50</u>	X/gamma	<u>RAD52</u> DSBR	+++	0	++	Sporulation defective; Meiotic Rec <sup>-</sup>
<u>rad52</u>	X/gamma	<u>RAD52</u> DSBR	0	0	++	Sporulation defective; General Rec <sup>-</sup> ; Unable to switch mating types

For a complete discussion of all mutants phenotypes refer to the body of the text. Excellent reviews discussing yeast epistasis groups have recently been presented by Game (71) and Haynes and Kunz (96). <sup>a</sup>rem1 is slightly UV sensitive at high fluence levels. <sup>b</sup>ER is Excision Repair; DSBR is Double-Strand Break Repair. <sup>c</sup>Not categorized because of slight sensitivity. <sup>d</sup>+ = wild type; 0 = decreased levels; +++ = increased recombination. <sup>e</sup>+ = proficient; 0 = absent or reduced. <sup>f</sup>± = small reduction relative to wild type; ++ and +++ = varying levels of increased mutation.

repair as a gene conversion. These same functions are not required for the cross-over events observed. Interpretation of the results is presented by a pathway of gene function interactions leading to the production of a recombinant chromosome.

We also report the cloning of REM1. The clone complements all rem1 phenotypes and suprisingly it complements a UV sensitive mutation - rad3-2. The RAD3 gene is one of the more interesting DNA repair products. From gene disruption studies, a null allele of RAD3 is unable to germinate from spores, and the gene product is involved in the incision step of excision-repair (202,203). We show that the rem1 mutations are mutant (but UV resistant) alleles of the essential function RAD3.

## MATERIALS AND METHOD

### Strains and culture conditions

The yeast strains used in this study are isogenic isolates containing the various recombination and repair mutations described throughout the text and in Table 15. All strains have been backcrossed at least three times to the isogenic strains K210-4A, K210-6D, K264-5B, or K264-10B (supplied by Dr. S. Klapholz, University of Chicago). Haploids contain either of two sets of mutations which, when intercrossed, generate seven different heteroallelic and two heterozygous drug-resistance markers used for the measurement of recombination (Figure 10 and reference 143). Haploid genotypes, for either mating type, were: i) ho lys2-1 tyrl-1 his7-2 can1<sup>R</sup> ura3-13 ade5 met13-d trp5-2 leul-d ade2-1; or ii) ho lys2-2 tyrl-2 his7-1 ura3-1 met13-c cyh2<sup>R</sup> trp5-d leul-12 ade2-1. Strains not of these configuration are noted in the text. The rad1-2 and rad3-2 mutations originated from Dr.L. Prakash (University of Rochester). The rad4 mutation was from the Yeast Genetic Stock Center (Berkley, CA).

Yeast media formulations and standard techniques for sporulation, dissection, testing of auxotrophic requirements, and segregation analysis have been described (143). Procedures for determining recombination levels are as described by Malone and Hoekstra (143).

The E. coli strains used throughout the course of this

work were HB101, MC1006, or RK1400 (237). Media for growth of E. coli are described in Maniatis et al. (147).

### Isolation of RAD3

Spheroplasts of the ura3-52 rad3-2-containing S. cerevisiae strain LP2649-1A (97) were transformed to uracil independence using a yeast pool constructed in YEp24 (kindly supplied by Carl Falco, E. I. DuPont deNemours and Co., Wilmington, Delaware). Agar overlays containing the transformants were lifted off the regeneration plates and mascerated in a small volume of 0.2 M sodium phosphate buffer (pH 7.5). The mixture was diluted and transformants plated for single colonies on uracil omission medium. Colonies (22,500) were picked to a grid pattern on synthetic defined medium lacking uracil, grown overnight at 30°C, replicated to uracil omission medium and the replicate exposed to a UV light source (two 15 Watt G.E. model G15T8 Germicidal Lamps, fluence exposure of 100 J/m<sup>2</sup>). The exposed plates were immediately wrapped in foil to avoid photoreactivation and cells grown for two days. After retesting of resistant patches, five repeatedly demonstrated approximately wild type levels of UV resistance. Included as controls on each plate was a RAD3 and rad3-2 strain containing the vector, YEp24. All five demonstrated cosegregation of the plasmid with UV resistance.

The plasmids were rescued in E. coli from total yeast DNA preparations. Restriction analysis demonstrated that

all five have the same insert. One of these, pMFH100, was chosen for subsequent analysis.

#### DNA manipulation

Restriction analysis followed the recommendation of manufacturers. Enzymes were purchased from Bethesda Research Laboratories (Gaithersburg, MD) and New England Biolabs (Beverly, MA). Procedures for transformation, DNA isolation, plasmid purification, and DNA blot hybridizations have been described (103,104,106).

#### Sucrose gradient analysis

The procedure for sucrose gradient analysis of yeast chromosomal DNA was as described by Resnick et al. (194 - 201). Briefly, cells were grown overnight in complete synthetic medium containing 12.5 ug/ml adenine and 10 mCi of <sup>3</sup>H-adenine or <sup>14</sup>C-adenine (RPI). Where indicated, the label was chased for one generation in synthetic medium containing 50 ug/ml adenine. Gentle cell lysis was accomplished by incubating cells in 0.1 M Tris Sulfate (pH 9.3), 0.01 M EDTA, 0.3 M 2-Mercaptoethanol for 10 min at 37°C. Cells were washed and resuspended in 50 mM K<sub>2</sub>HPO<sub>4</sub> (pH 6.5), 10 mM EDTA (at 10<sup>8</sup> cells/ml) and 2 X 10<sup>7</sup> cells added to 20 µl of 12.5% NaSarkosyl, 20 µl of 2 mg/ml RNase A, 20 µl of 2 mg/ml Zymolyase 60,000. The mixture was incubated at 37°C for 10 min in a 1000 µl pipetor tip which had been shortened, to enlarge the bore, and sealed with parafilm. Ten µl of 5

mg/ml Proteinase K was added to the mixture and held for 30 min. Just prior to loading, 50  $\mu$ l of a solution containing 20 mg/ml NaSarkosyl, 30 mg/ml Na deoxycholate, 50 mg/ml Na lauryl sulfate was added to complete lysis. Pre-formed 5 - 20% linear gradients were gently loaded by placing the pipettor tip on an automatic pipet gun and slowly dialing the lysed cells onto the gradient. Centrifugation was in an SW50.1 rotor at 9,000 R.P.M. for 16 hours.

Gradients were fractionated from the bottom and each fraction made to 0.3 M NaOH, incubated at 37°C for 60 min, neutralized with HCl and an equal volume of ice cold 10% TCA added. The precipitate was collected on Whatman glass fiber filters, dried, and counted using a toluene-based scintillation cocktail. Measurements of radioactivity were performed using a Unilux II (Nuclear Chicago) or a LS-5801 (Beckman) liquid scintillation counter.

Number average molecular weights were calculated as  $M_n = [(\sum_x^y C_i)/(\sum_x^y C_i/M_i)]$  (198), where  $C_i$  and  $M_i$  are the counts and molecular weight of DNA in the  $i^{\text{th}}$  fraction.  $M_i$  was determined from the relationship  $d_i/d_t = (M_i/M_t)^{0.38}$ , where  $d_i$  is the distance from the top to fraction "i" and  $d_t$  is the distance to the average position of the size standard. The values  $M_i$  and  $M_t$  are the molecular weights of yeast DNA in fraction "i" and the size standard DNA [phage T4 was assumed to be  $1.2 \times 10^8$  daltons (198)].

## RESULTS

### High levels of gene conversion in rem1 cells requires excision-repair functions

From previous work, it was postulated that rem1-produced hyper-recombination was performed by the recombination-repair (double-strand break) functions RAD50 and RAD52 (143). Considering that excision-repair functions act on several different DNA lesions, including structural and chemical distortions like pyrimidine dimers and psoralen cross-links (5,9,90) and subtle changes like yeast DNA methylated in vivo by the E. coli dam enzyme (reference 102 and Chapter 7), we asked whether yeast excision-repair functions were involved in the recognition and response to rem1 lesions. The excision-repair mutations studied in combination with rem1 were rad1-2, rad3-2 and rad4. The double mutants, rem1 rad1-2 and rem1 rad4, are viable (Table 16). The double mutant rem1 rad3-2 could not be constructed because only parental tetrads were found from doubly heterozygous crosses (see below). The level of spontaneous mitotic intergenic and intragenic recombination in rem1 rad1 and rem1 rad4 strains was measured at a number of loci on several chromosomes. As shown in Table 17, either of the excision-repair mutations rad1 or rad4 reduce the level of rem1-stimulated intragenic recombination essentially back to the normal wild type level. This implies that the excision-repair functions are required for the hyper-rec phenotype of



Table 16 Analysis of various rem1/REM1 RAD/rad diploids

Diploid Genotype	Segregant Genotype <sup>a</sup>			
	REM1 RADX	rem1 RADX	REM1 radx	rem1 radx
<u>rem1-2</u> + <u>b</u> + rad50-1	53	56	55	0
<u>rem1</u> + <u>b</u> + rad52-1	208	225	202	0
<u>rem1-2</u> + + rad1-2	35	34	33	37
<u>rem1-2</u> + + rad4	28	161	160	27

Diploids heterozygous for rem1 and rad were sporulated and dissected by micromanipulation. After 3 days, spores were examined for viability. Viable spores were tested for rem1 and rad.

<sup>a</sup>RADX refers to the rad mutation for a given diploid

<sup>b</sup>Compiled data from Malone and Hoekstra (141) for rem1-1 and rem1-2 (Chapter 2).

Table 17 Spontaneous mitotic recombination in excision-repair deficient rem1-containing strains

GENOTYPE	NO. <sup>a</sup> CULTURES	RELATIVE RECOMBINATION FREQUENCIES								
		INTRAGENIC							INTERGENIC	
		LYS2	TYR1	HIS7	URA3	MET13	TRP5	LEU1	CAN1	CYH2
+	19,23	1.0	1.0	1.0	1.0	1.0	1.0	1.0	1.0	1.0
+		(0.4)	(0.3)	(0.36)	(0.51)	(4.2)	(3.1)	(3.2)	(22)	(41)
<u>rem1-2</u> rem1-2	9,19	16	36	13	19	8.8	8.9	24	7.4	8.1
<u>rad1-2</u> rad1-2	3,9	--	1.7	1.1	0.9	--	--	1.8	5.2	3.2
<u>rad4</u> rad4	6,12	0.55	0.36	0.55	0.83	1.5	1.5	1.0	7.5	7.4
<u>rem1 rad1</u> rem1 rad1	6,16	--	1.2	1.6	0.62	0.91	--	--	10	11
<u>rem1 rad4</u> rem1 rad4	6,16	0.65	1.6	1.5	1.7	1.3	1.9	2.3	11	3.3

Recombination levels are geometric mean frequencies normalized relative to wild type levels. The wild type recombination frequencies ( $\times 10^5$ ) are given in brackets below the first row.

<sup>a</sup> The first value indicates the minimum number of cultures examined for gene conversion. The second number indicates the number of cultures examined for crossing-over.

rem1. Interestingly, the level of intergenic crossing-over, as measured by drug-resistance at CAN1 and CYH2, was not reduced.

To demonstrate that the reduction of intragenic recombination was in fact due to the presence of the excision-repair mutations and not due to reversion of the rem1 allele, a number of recombinant colonies from double mutant diploids were sporulated and tetrads dissected. In every case (10/10 asci germinating four live spores), all segregants showed both the rem1 and rad1 (or rad4) phenotypes (data not shown). Thus, this trivial explanation for the reduction of rem1 hyper-recombination in rem1 rad1-2 or rem1 rad4 strains is not warranted. To confirm that the selected prototrophs from heteroallelic configurations were convertants and not cross-over events, ten Ura<sup>+</sup> and ten Leu<sup>+</sup> colonies from each mutant class presented in Table 16 were sporulated and dissected. In all recombinants examined, the segregant genotypes indicated the recombination event must have been a gene conversion since reciprocal double mutants were not observed (data not shown). Therefore, the elevation of mitotic gene conversion by the rem1 mutation requires at least the RAD1 and RAD4 excision-repair functions.

Increased crossing-over in rem1 cells occurs  
in the absence of excision-repair

We were suprised the excision-repair mutations

reduced rem1 gene conversion but not crossing-over, as current molecular models of mitotic and meiotic recombination propose gene conversion and crossing-over to be associated events (50,63,156,239). The method of measuring mitotic crossing-over in yeast has historically relied on the use of selectable drug-resistance markers (50). The level of resistance from heterozygous configurations conferring sensitivity, such as can1<sup>R</sup>/CAN1<sup>S</sup>, is measured as an indicator of intergenic recombination. Unfortunately, chromosome loss of the sensitivity allele can also contribute to the population of cells able to grow in the presence of a drug (139,142). We tested the possibility that high drug-resistant frequencies in rem1 rad1 and rem1 rad4 strains were due to chromosome loss by constructing strains to measure the relative contribution of recombination and chromosome loss to a drug-resistant population. The chromosome configurations as well as the procedure for measuring the relative contributions to the putative cross-over population are given in Figure 10. Table 18 gives the level of chromosome loss in wild-type, rem1, rad1-2, rad4 and the double mutant strains. While chromosome loss relative to wild-type is elevated approximately ten-fold in all mutant strains, the rem1-2 rad1-2 and rem1-2 rad4 double mutants show no more chromosome loss than the single mutants. We conclude that loss cannot explain our results. Also, the level of chromosome loss in wild type strains, for the

Figure 10 Chromosome configurations for measuring chromosome loss. Heteroallelic and hetrozygous diploids are constructed with the genotype given in the top box. For chromosome V, canavanine-resistance is selected, while for chromosome VII, cyhcloheximide-resistance is selected. Not all possible combinations are shown, only selected cases. To follow chromosome loss versus mitotic recombination, markers on opposite arms or distal to the drug-resistance are measured in drug-resistant cells. Although shown in the figure, chromosome loss need not be associated with reduplication.

<sup>a</sup>Loss (with reduplication) of Chromosome V.

<sup>b</sup>Mitotic cross-over between centromere and CAN1.

<sup>c</sup>Loss (with reduplication) of chromosome VII.

<sup>d</sup>Mitotic cross-over between centromere and CYH2.

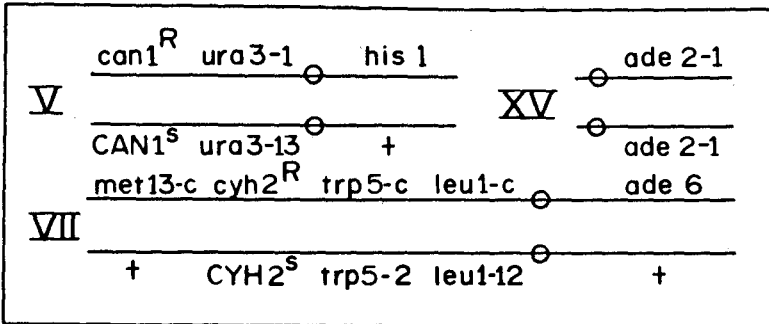

Phenotype : Red ; Cycloheximide - sensitive ; Histidine prototroph ; Canavanine - sensitive.

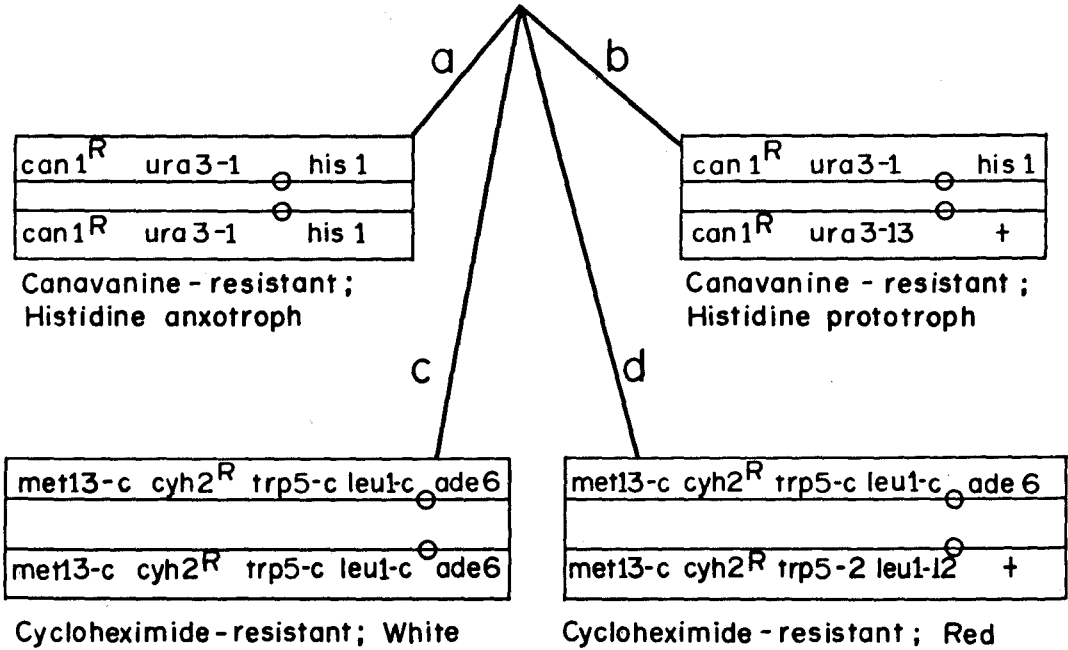

Table 18 Chromosome loss in rem1-containing strains

DIPLOID GENOTYPE	No. CULTURES	CHROMOSOME V <sup>a</sup>			CHROMOSOME VIII <sup>b</sup>		
		Can1 <sup>R</sup> FREQ (X10 <sup>4</sup> )	CHL <sup>c</sup> FREQ (X10 <sup>6</sup> )	% <sup>d</sup>	Cyh2 <sup>R</sup> FREQ (X10 <sup>4</sup> )	CHL <sup>c</sup> FREQ (X10 <sup>6</sup> )	% <sup>d</sup>
<u>+</u> <u>+</u>	12	3.0	2.8	0.93	3.1	2.1	0.66
<u>rad1-2</u> <u>rad1-2</u>	6	10	29	2.8	7.9	1.4	0.17
<u>rad4</u> <u>rad4</u>	8	15	17	1.1	12	18	1.5
<u>rem1-2</u> <u>rem1-2</u>	8	27	23	0.85	54	29	0.55
<u>rem1 rad1</u> <u>rem1 rad1</u>	8	16	7	1.1	12	6.5	0.54
<u>rem1 rad4</u> <u>rem1 rad4</u>	8	20	15	0.74	22	4.7	0.21

The level of chromosome loss contributing to the drug-resistant population was determined as shown in figure 10.

<sup>a</sup>On average, 880 can1<sup>R</sup> colonies per diploid were picked to master plates and the his1 and hom3 configurations determined for the opposite chromosome arm.

<sup>b</sup>Approximately 330, on average, cyh2<sup>R</sup> colonies per diploid were picked and tested for their chromosome VIII configuration.

<sup>c</sup>Frequency of Chromosome Loss (CHL)

<sup>d</sup>Percent refers to the relative amount of chromosome loss occurring in a drug resistant population.

frequency of drug-resistance in these strains appears to be an accurate indicator of recombination. The excision-repair mutations specifically reduce gene conversion but do not reduce hyper-crossing-over in rem1 mutants.

Excision-repair mutations eliminate the need for recombination-repair functions in rem1 mutant strains

Since rem1 rad50 and rem1 rad52 double mutants are inviable (Tables 17 and 19 and reference 143), we previously proposed that rem1 strains contain a recombinogenic lesion requiring double-strand break repair functions for resolution (Chapter 2 and reference 141). As described above, rem1 hyper-gene conversion is dependent upon excision-repair functions. We therefore determined whether the reduction of rem1 gene conversion by the rad1 and rad4 excision-repair mutations would rescue the double mutant inviability of rem1 rad50 and rem1 rad52. As shown in Table 19, the mutations rad1-2 and rad4 restore viability to the double mutants. Triple mutants with rem1-2 in combination with rad1-2 (or rad4) and rad50-1 (or rad52-1) are viable. We interpret this to mean that mutationally inactivating excision-repair functions in rem1 strains blocks the formation of a lesion that requires double-strand break repair for resolution and viability.

The recombination phenotype of triple mutants containing rem1-2 with rad1 or rad4 and rad50-1 or rad52-1 was examined (Table 20). The observations that rad1 and rad4



Table 19 Excision-repair mutations rescue the double mutant inviability of *rem1 rad50* and *rem1 rad52* double mutants

DIPLOID GENOTYPE	SEGREGANT GENOTYPE								RAD MUTATION	
	RADX	RADX	RADX	radx	RADX	radX	radX	radX	"X" <sup>a</sup>	"Y" <sup>b</sup>
	RADY	RADY	radY	RADY	radY	radY	RADY	radY		
	REm1	rem1	REm1	REm1	rem1	REm1	rem1	rem1		
<u>rem1 rad1</u> + + + rad52	24	31	26	22	0	30	26	26	<u>rad1</u>	<u>rad52</u>
<u>rem1 rad1</u> + + + rad50	31	36	24	18	0	32	35	29	<u>rad1</u>	<u>rad50</u>
<u>rem1 rad4</u> + + + rad52	57	6	40	4	0	10	50	45	<u>rad4</u>	<u>rad52</u>
<u>rem1 rad4</u> + + + rad50	47	6	38	8	0	8	40	41	<u>rad4</u>	<u>rad50</u>

The mutations used in this experiment were rem1-2, rad1-2, rad50-1, and rad52-1. Triply heterozygous diploids were constructed, sporulated, dissected, and viable spores examined for the presence of rem1 and/or rad mutations. The 8 possible segregant genotypes are presented.

<sup>a</sup>"X" refers to the excision-repair mutation in the diploid

<sup>b</sup>"Y" refers to the recombination-repair mutation in the diploid

Table 20 Spontaneous mitotic recombination in triple mutants

DIPLOID GENOTYPE	NO. CULTURES	RELATIVE RECOMBINATION FREQUENCIES								
		INTRAGENIC							INTERGENIC	
		URA3	HIS7	TYR1	LYS2	LEU1	MET13 <sup>c</sup>	TRP5	CAN1	CYH2
<u>rad52</u> <u>rad52</u>	6 <sup>a</sup>	0.13	0.13	0.03	0.11	----	1.5	---	0.45	0.18
<u>rad1 rad52</u> <u>rad1 rad52</u>	6	---	0.25	0.14	0.40	----	1.3	---	68	9.8
<u>rem1 rad1 rad52</u> <u>rem1 rad1 rad52</u>	6	0.051	0.15	0.042	0.20	----	0.91	---	135	13
<u>rad4 rad52</u> <u>rad4 rad52</u>	6	0.024	0.053	---	0.42	----	0.41	---	55	28
<u>rem1 rad4 rad52</u> <u>rem1 rad4 rad52</u>	6	0.20	0.50	0.37	---	----	2.8	---	---	11
<u>rad50</u> <u>rad50</u>	10 <sup>b</sup>	13	7.1	27	---	18	13	11	50	34
<u>rad1 rad50</u> <u>rad1 rad50</u>	12	2.6	1.5	5.5	1.0	4.9	5.0	10	13	45
<u>rem1 rad1 rad50</u> <u>rem1 rad1 rad50</u>	6	6.7	5.9	40	14	3.1	8.3	---	136	129
<u>rad4 rad50</u> <u>rad4 rad50</u>	6	4.8	1.5	16	44	---	---	---	30	15
<u>rem1 rad4 rad50</u> <u>rem1 rad4 rad50</u>	9	5.5	6.7	58	---	2.7	3.4	3.8	51	51

The alleles used are rem1-2, rad1-2, rad50-1, and rad52-1. Values are normalized to wild type. The wild type values are given in Table 17.

<sup>a</sup>Data from Malone and Esposito (1980 and 1981).

<sup>b</sup>Data from Malone, Jordan, and Wardman (146) and this work.

<sup>c</sup>Recombination values are elevated at met13 heteroalleles because of a high mutation and suppression rate (140).

reduce rem1 gene conversion but not rem1 crossing-over (Table 17) and that excision-repair mutations rescue rem1-2 rad50-1 and rem1-2 rad52-1 double mutant inviability (Table 19) together imply that rem1-created hyper-crossing-over need not proceed through the RAD52 recombination-repair pathway. If so, triple mutants should exhibit rad50-1 and rad52-1 levels of gene conversion and rem1 levels of crossing-over. As shown in Table 20, rad52-1-containing triple mutants are reduced for gene conversion but are increased for drug-resistance from heterozygous configurations conferring sensitivity. Strains with the rad52-1 mutation alone increases chromosome loss a few fold (86, 139). Therefore, although not measured, the level of chromosome loss in rad1 rad52 and rad4 rad52 double mutants may also be increased. Subject to this possibility, the data is consistent with rem1 hyper-crossing-over not being reduced by rad52-1 (see Discussion and Chapter 8). Similarly, triple mutants with rad50-1 rather than the rad52-1 mutation have approximately the double mutant rad1-2 rad50-1 or rad4 rad50-1 level of gene conversion but are slightly increased for crossing-over. The rad50-1 mutation is hyper-rec (139), making the interpretation of double and triple mutant phenotypes difficult. However, at least part of the hyper-recombination (crossing-over) in rem1-2 strains may occur independently of the RAD52 recombination-repair epistasis group.

Since rem1 rad52 and rem1 rad50 double mutants are inviable, we have proposed that lethal recombinogenic lesions occur in rem1 strains. Because the RAD52 repair system responds to and repairs double-strand breaks, one possibility for the rem1 DNA lesion is a double-strand break. To test this hypothesis we examined rem1 DNA on neutral sucrose gradients. Consistent with the genetic evidence, the No. average molecular weight for the furthest sedimenting chromosomal peak ( $M_n$ , calculated from three gradients) of rem1-2 DNA ( $2.18 \times 10^8$ ) is slightly smaller than an isogenic wild-type ( $2.65 \times 10^8$ ) (Figure 11). The curves in Figure 11 are from a representative 5 - 20% neutral sucrose gradient of DNA prepared from strains which have had the label chased for a generation after an overnight pulse. The calculated  $M_n$  for wild type is similar to the value reported by Resnick and Martin (198). Interpolating our values for rem1-2 and REM1 with published dose curves (198), it appears that the change in molecular weight is similar to an X-ray dose of less than 5 Krad [1 - 2 strand breaks per cell (198)]. In terms of wild type cell viability, a dose of 5 Krad reduces the surviving fraction only a few percent at most (74,186,198). In rad52 cells, however, a dose of 5 Krad reduces viability 2 - 3 orders of magnitude. This is consistent with our interpretation for the double mutant inviability.

The interpretation of the data in Figure 11 is com-

Figure 11 Sucrose gradient analysis of rem1 cells. REM1 and rem1-2 stocks were grown overnight in synthetic medium containing  $^3\text{H}$  or  $^{14}\text{C}$ -adenine as described in Materials and Methods. When at a concentration of  $1 \times 10^7$  cell/ml, cells were resuspended in medium containing  $50 \mu\text{g/ml}$  unlabelled adenine and grown for 1 generation. Sucrose gradients (5 - 20%) were formed and run as described in Materials and Methods. Size standards (phages T4 and T7) are shown.

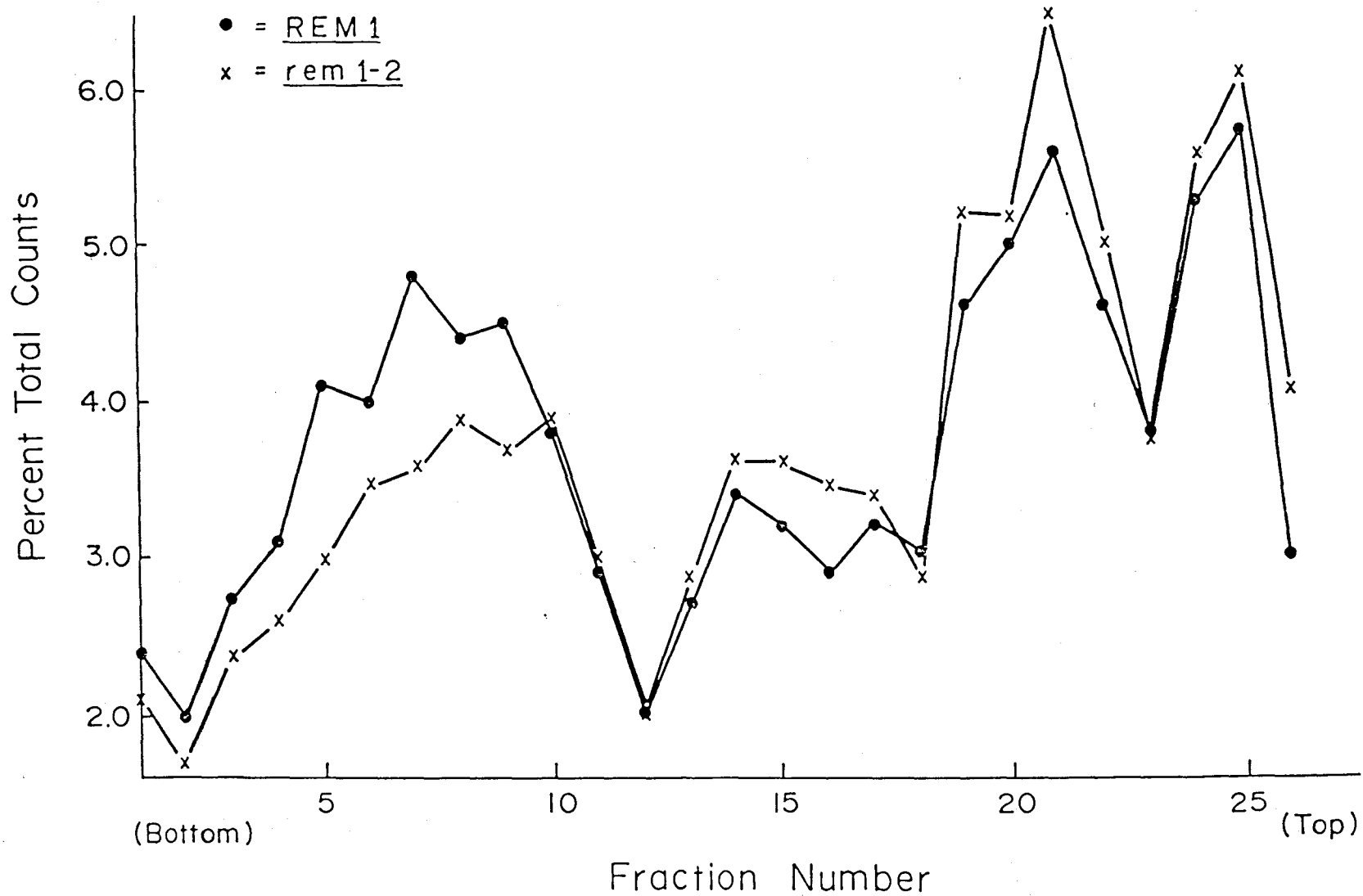

plicated because these strains contain mitochondria which obscure the upper portion of the gradient. We also wanted to continuously label DNA so that both newly replicated and older DNA could be examined. Much of the label, in the absence of a chase period, appears in the upper portion of the gradient for both mitochondrial and chromosomal DNA. To allow us to examine all the chromosomal DNA, we generated mitochondrial-less ("petite") strains by growing haploid parents overnight in the presence of ethidium bromide (229), and screened colonies for the inability to grow on glycerol. (Strains were shown to be rho<sup>0</sup> by DAPI staining, kindly performed by Chuck Edwards.) The rem1 phenotype was maintained in the petite isolates when recombination levels were determined by a replica plate assay (data not shown). Petite wild type strains have normal mitotic recombination levels (R. E. M., unpublished observation). We examined both newly replicated and continuously labelled DNA from these strains by growing overnight in the presence of label and examining profiles on 5 - 20% neutral sucrose gradients without a chase (Figure 12). From the curve, we infer that newly replicated wild type DNA is larger than newly replicated rem1 DNA. Thus, by both sucrose gradient analyses, rem1 DNA is smaller than wild type DNA. We note, however, that by either analysis, the shift in profiles is not a large one. This is not surprising for two reasons. First, the strains are competent for double-strand

Figure 12 Neutral sucrose gradient analysis of rem1. Mitochondrial-less REM1 and rem1-2 cells were grown overnight to  $2 \times 10^7$  cell/ml in  $^3\text{H}$  or  $^{14}\text{C}$ -adenine, mixed, and run on 5 - 20% neutral sucrose gradients as described in Materials and Methods. The normalized ratio of REM1/rem1-2 for 8 separate gradients is plotted as a function of sedimentation. To generate this figure we have taken the ratio of REM1:rem1 per gradient fraction and normalized to the ratio of total counts per gradient. This sets a normalized value of unity if REM1 equals rem1. Regions of the curve greater than 1.0 indicate more REM1 DNA is present compared to rem1. Values less than 1.0 indicate the amount of DNA from rem1 is greater than REM1.



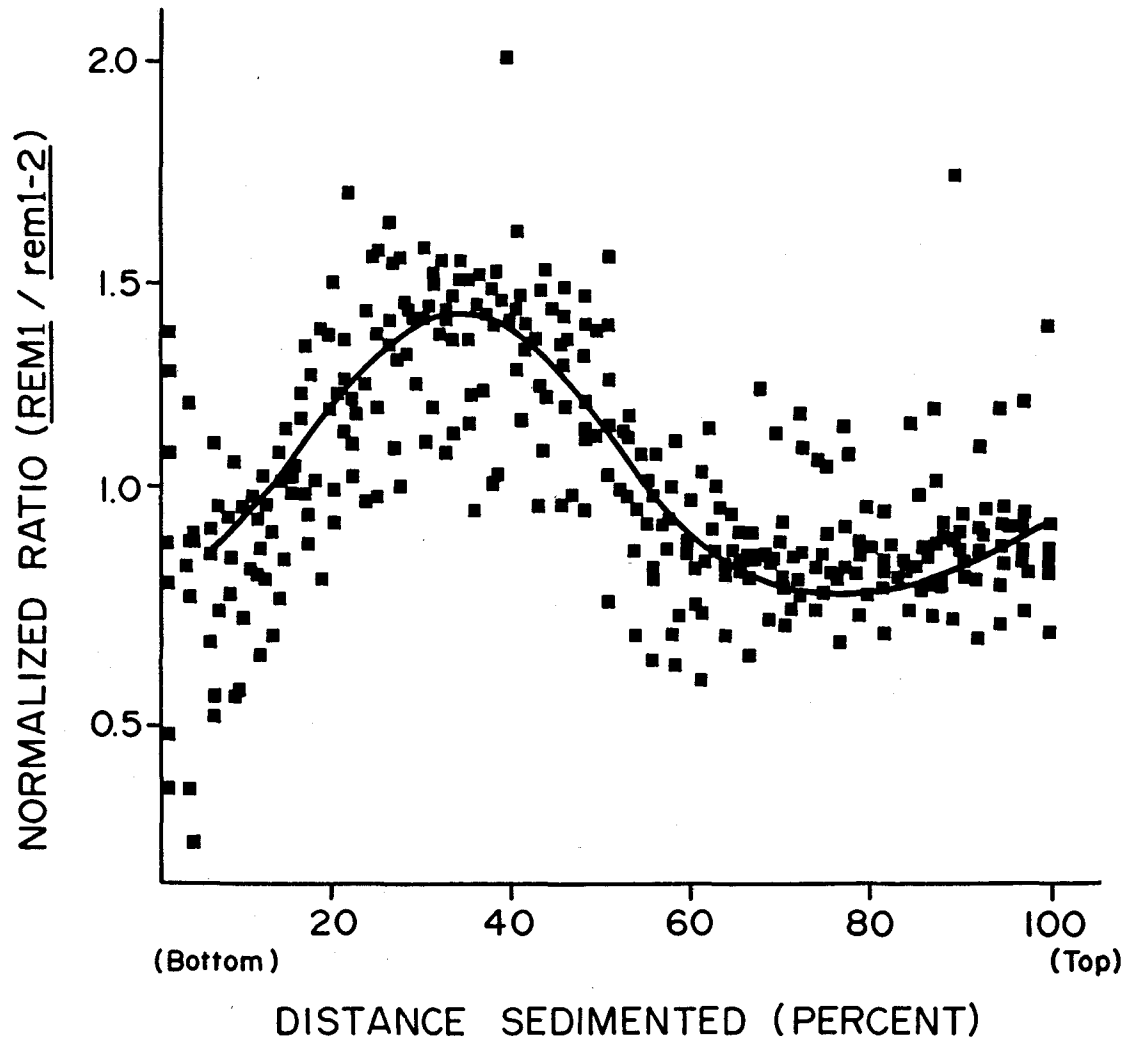

break repair and breaks probably do not persist for long. second, the increased recombination in rem1 strains is, at most, 10 - 20 fold higher than REM1 for any given locus. Only a few lesions (1 - 2) per cell per generation would be needed to generate this increase (72). The strand breaks observed are consistent with the genetic predictions from double mutant inviability. We propose that these double-strand breaks are not the primary rem1 DNA lesion, but rather are a consequence of the action of the excision-repair system on the primary lesion (see Discussion).

#### The cloning of REM1

From the data in Tables 16 and 19 we noticed the parental class of tetrads grossly out-numbered non-parental or tetra-type tetrads, indicating that the REM1 locus is linked to RAD4. Examination of the current S. cerevisiae map showed RAD3 linked to RAD4 (162) by the same map distance as REM1. We determined if REM1 is close to RAD3 by genetic mapping. REM1 is tightly linked to RAD3; only parental-type tetrads were observed in crosses between rem1-1 (or rem1-2) and rad3-2 (Table 21). In fact, examination of all spores from these crosses showed no recombinant types were ever produced. From the mapping data, the rem1 mutations are less than 1 cM. from RAD3 (approximately 1 - 2 Kb by current estimates). On this basis, the rem1 mutations could be alleles of the essential mitotic function RAD3.

Our approach to determining if REM1 and RAD3 were the

Table 21 The rem1 mutations are tightly linked to RAD3

GENOTYPE	SEGREGATION PATTERN <sup>a</sup>			MD <sup>b</sup> (cM)
	<u>P</u>	<u>T</u>	<u>NPD</u>	
<u>rem1-2</u> + + <u>rad4</u>	59	21	2	20.2
<u>rem1-1</u> + + <u>rad4</u>	58	14	3	21.3
<u>rad3-2</u> + + <u>rad4</u>	89	28	4	21.4
<u>rem1-2</u> + <sup>c</sup> + <u>rad3-2</u>	26	0	0	<1.9
<u>rem1-1</u> + <sup>c</sup> + <u>rad3-2</u>	49	0	0	<1.0
<u>rem1-1</u> + <sup>d</sup> + <u>rem1-2</u>	81	0	0	<0.6

<sup>a</sup>p, NPD, and T refer to parental, non-parental, and tetra type tetrads respectively.

<sup>b</sup>Map distances were calculated using the formula  $MD = ((T+6N) / (P+T+NPD)) \times 100/2$  (173)

<sup>c</sup>REM1 RAD3, rem1-2 rad3-2, or rem1-1 rad3-2 spores have not been recovered out of 360 viable spores examined.

<sup>d</sup>All tetrads segregate 4:0 for hyper-recombination

same gene was to clone RAD3 and determine if it complements the reml phenotypes. Spheroplasts of the genotype ura3-52 rad3-2 were transformed to uracil independence using a cloned yeast pool constructed in the episomal plasmid YEp24 (kindly supplied by Carl Falco). Transformants were tested for UV resistance and clones demonstrating wild type UV resistance chosen for further use. A plasmid, pMFH100, was isolated in E. coli which complements the rad3 mutation for UV sensitivity (Figure 13) but does not complement other UV-sensitive mutations such as rad1-2 and rad4 (data not shown). Cosegregation of the plasmid and UV sensitivity is observed when plasmid-containing strains are grown non-selectively and Ura<sup>+</sup> or Ura<sup>-</sup> cells tested for UV resistance (Figure 13). pMFH100 is as proficient as pNF3001 [a RAD3-containing plasmid kindly supplied by L. Naumovski and E.C. Friedberg (166)] for complementing rad3-2 UV sensitivity (Figure 14).

pMFH100 complements for the reml semi-dominant, hyper-rec phenotype (Figure 15). Diploid strains homozygous for reml-1 or reml-2, containing multiple heteroallelic auxotrophies and heterozygous drug-resistance markers, were transformed with pMFH100. The plasmid containing diploids were tested for their level of recombination. Plasmid pMFH100, which contains a 2  $\mu$  origin of replication (conferring high copy number), is able to reduce the level of reml-produced hyper-recombination (both gene conversion and cros-

Figure 13 Map of pMFH100 and demonstration that the clone co-segregates with UV<sup>R</sup>. The plasmid was rescued in *E. coli* strain RK1400 by transforming cells with total yeast DNA. E is EcoRI; H is HindIII; K is KpnI; SI is SalI; B is BalI; C is ClaI; HI is HpaI; Sm is SmaI; B is BamHI; S is Sau3AI; BII is BglII; HII is HpaII; P is PstI. The 3.9 Kb KpnI - SalI fragment is a subclone (pMFH102) in pJO158 (35) that complements rad3-2 UV-sensitivity (Fig. 14) and rem1 hyper-recombination (Table 17). The restriction map of pMFH102 is identical to Naumovski and Friedberg (167) and Higgins et al. (99). The insert in pMFH100 is larger than those shown by Naumovski and Friedberg (166) and Higgins et al. (99) but the region surrounding the KpnI - SalI fragment is identical to those RAD3 clones previously reported. The inset figure demonstrates that the 5 RAD3 isolates co-segregate plasmid and UV<sup>R</sup>. UV-resistant isolates were grown non-selectively for a few generations, picked to YPD masters and replicated to complete synthetic medium or uracil omission medium. A complete plate was exposed to 100 J/m<sup>2</sup> UV and all three plates grown at 30° C overnight. The "X's" are LP2649-1A (ura3-52 rad3-2) containing YEp24 and GF206 (URA3 RAD3).

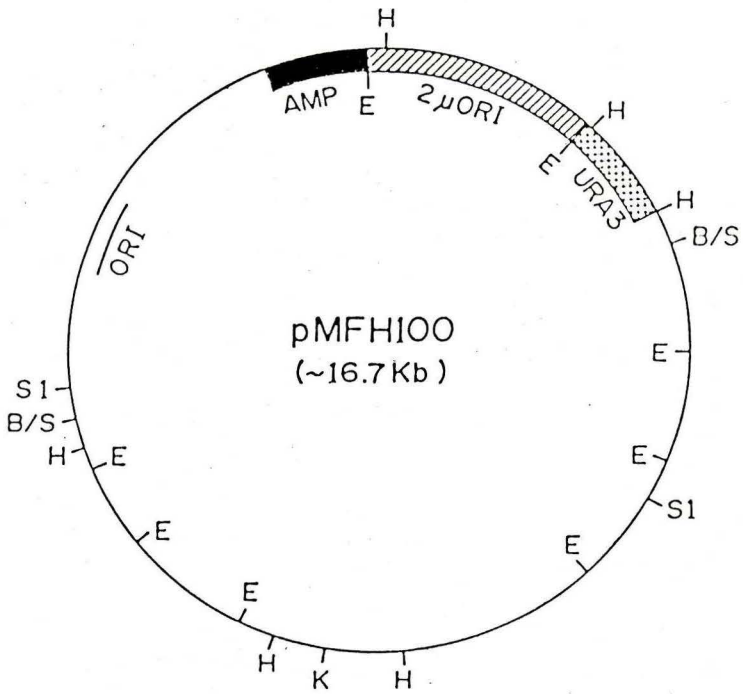

500bp

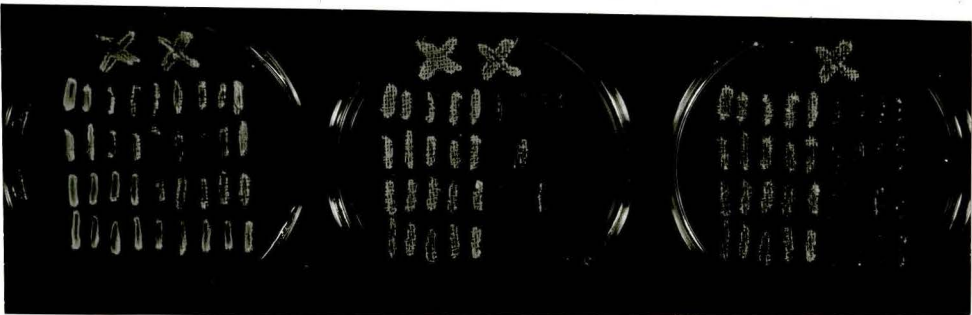

COMPLETE

URA

UV

Figure 14 Survival curves for rad3-2 strains containing various RAD3 clones. The plasmids used are pMFH100 (original isolate in YEp24), pMFH102 (3.9 Kb KpnI - SalI fragment in pJO158), and pNF3001 [4.5 Kb EcoRI fragment in YCp50 (166)]. The cells were grown to mid-log phase in selective medium, diluted, and plated on appropriate medium. Plates were exposed to varying doses of UV-irradiation, wrapped in foil to avoid photoreactivation, and grown for 3 days at 30°C. Surviving fraction represents the percent survival at a given dose relative to the untreated sample. All measurements were performed at least three times.

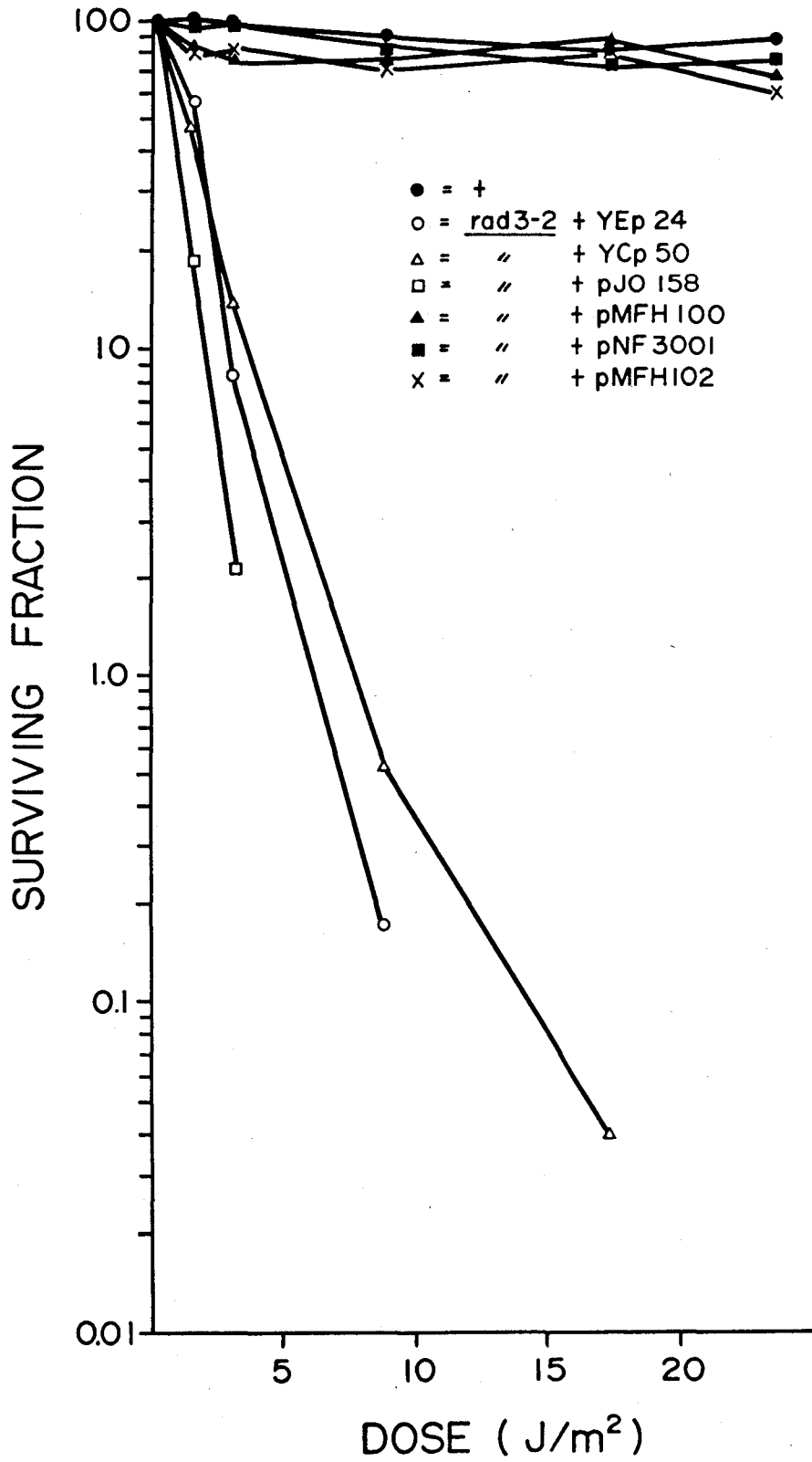



Figure 15 Demonstration that pMFH100 complements for rem1 hyper-recombination. rem1-1 and rem1-2 homozygous diploids were transformed with pMFH100 or YEp24. Isolates were struck to quartiles on uracil-ommission selective medium and grown overnight. The plates were replicated to various ommission and drug-containing media and grown at 30° C for 3 days. Strains with pMFH100 demonstrate approximately a 20 - 30 fold decrease in recombinant papillae for inter- and intragenic recombination.

rem1-2/rem1-2cyh2<sup>r</sup>/CYH2<sup>s</sup>rem1-2/rem1-2his7-1/his7-2leu1-c/leu1-12rem1-1/rem1-1met13-c/met13-dleu1-c/leu1

Table 22 Cloned fragments that complement for RAD3 UV sensitivity reduce rem1 hyper-recombination

RELATIVE RECOMBINATION FREQUENCIES							
GENOTYPE	HIS7	TYR1	LEU1	TRP5	MET13	CAN1	CYH2
<u>rem1-2</u>							
<u>YEp24</u>	50	--	67	34	--	13	49
<u>pMFH100</u>	(1.2)		(7.2)	(3.5)		(47)	(31)
<u>pJO158</u>	--	40	37	--	10	15	105
<u>pMFH102</u>		(0.072)	(1.6)		(0.63)	(20)	(12)
<u>YCp50</u>	20	--	15	--	--	3.6	9.4
<u>pNF3001</u>	(1.1)		(2.9)			(12)	(17)
<u>rem1-1</u>							
<u>YEp24</u>	--	--	26	15	--	25	55
<u>pMFH100</u>			(2.9)	(9.6)		(57)	(120)
<u>YCp50</u>	--	--	15	6.8	--	7.2	9.4
<u>pNF3001</u>			(1.1)	(5.1)		(98)	(76)

Values represent the ratio of geometric mean recombination frequencies for the vector alone relative to a given insert-containing plasmid. pMFH100 is the original RAD3 isolate contained in YEp24, pMFH102 is the 3.9 Kb KpnI - SalI RAD3 fragment subcloned in pJO158, and pNF3001 is a 4.5 Kb EcoRI RAD3 fragment in YCp50. Values in brackets represent the geometric mean recombination frequencies ( $\times 10^5$ ) for the insert-containing plasmids. For YEp24 and YCp50-based plasmids, 12 cultures were grown. For the pJO158-based plasmids, 15 cultures were grown. All experiments were performed on uracil omission (Yep24 and YCp50) or tryptophan omission (pJO158) medium lacking a specific auxotrophic requirement (double omission medium) or containing Canavanine sulfate or Cycloheximide, where required.

sing-over) approximately 10 - 20 fold (Table 22). Therefore the plasmid can complement both rad3-2 UV-sensitivity and rem1 hyper-recombination.

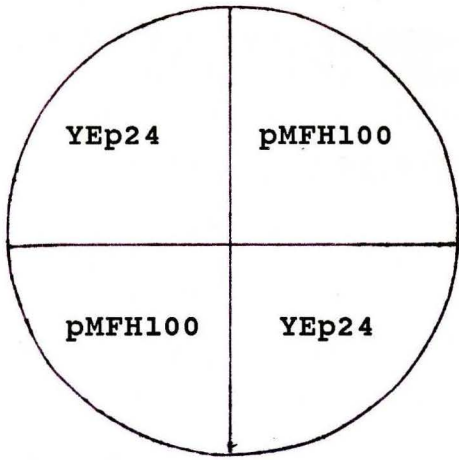
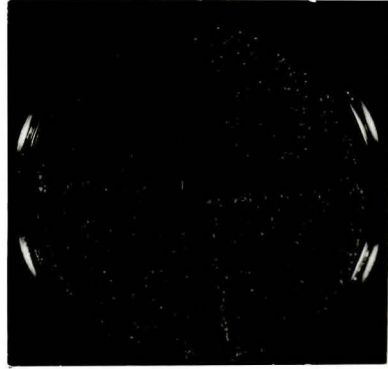
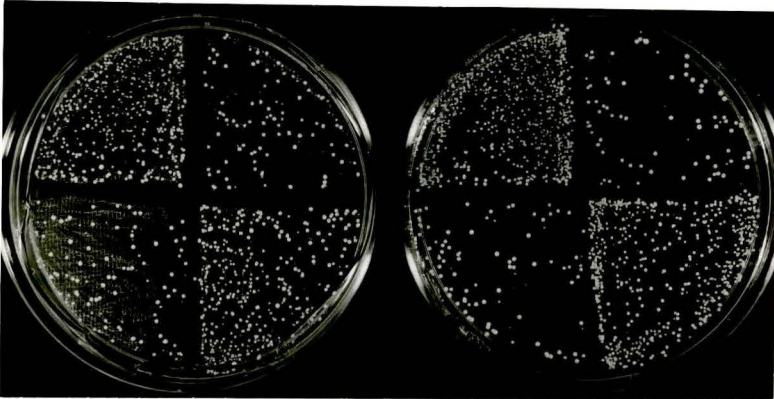
The rad50-4-4 mutation confers sensitivity to MMS at 35°C but not at 30°C (145). The double mutant rem1-2 rad50-4-4 is inviable at 35°C on complete synthetic medium, YPD medium and MMS-containing media. The double mutant is able to grow on all media at 30°C. A temperature-sensitive double mutant strain of rem1-2 rad50-4-4 was transformed with pMFH100 and the plating efficiency determined at 30°C and 35°C (Table 23). The plasmid pMFH100 restores the viability of the double mutant on complete medium at 35°C, consistent with the contention that the plasmid contains REM1. The plasmid does not complement the rad50 defect since transformants remain MMS sensitive at 35°C (data not shown). The restriction map for the insert in pMFH100 is identical to the RAD3 inserts described by Naumovski and Friedberg (166) and Higgins et al. (99). In addition, a 3.9 Kb KpnI - SalI fragment (Figure 13), subcloned into pJ0158 (35) (pMFH102), also complements for the hyper-rec phenotype of rem1-1 and rem1-2 (Table 22). This same subclone complements rad3-2 UV sensitivity (Figure 14). We find that the RAD3-containing plasmid pNF3001 complements the rem1 hyper-rec phenotype by causing a reduction in recombination levels when introduced into rem1-1 and rem1-2 homozygous diploids (Table 22). A 1.5 Kb BamHI - EcoRI internal fragment from

Table 23 Cloned REM1 complements for double mutant inviability

GENOTYPE	EFFICIENCY OF PLATING ( <u>35°/30°</u> )
<u>rem1-2</u>	0.98
<u>rad50-4-4</u>	0.81
<u>rem1-2 rad50-4-4</u> + YEp24	1.1 x 10 <sup>-5</sup>
<u>rem1-2 rad50-4-4</u> + pMFH100	0.65

The strains were grown overnight to mid-log phase and aliquots of serial dilutions plated on complete synthetic or uracil omission media (for plasmid-containing strains). Parallel plates were grown at 30° and 35°. For determinations at 35°, all media was pre-warmed.

pNF3001 specifically hybridizes to our plasmids (pMFH100 and pMFH102) at the region identified by Naumovski and Friedberg (166) and Higgens et al. (99) as the RAD3 gene (Figure 16). Therefore, we feel that rem1-1 and rem1-2 are alleles of the yeast essential/excision-repair function RAD3.

Figure 16 The rem1-complementing plasmid hybridizes with a verified RAD3 internal fragment. Plasmids were digested with various enzymes, run overnight in 0.8% agarose, blotted to nitrocellulose, and hybridized with a 1.5 Kb BamHI - EcoRI fragment from pNF3300 (167). Enzyme abbreviations are as in Figure 13. Size standards are lambda HindIII fragments. Lanes 1 - 6 = pMFH100, Lanes 7 and 8 = pNF3001, Lane 9 = pNF3300. Enzymes used for a given lane were: (1) E - H, (2) BII, (3) BII - E, (4) B, (5) B - E, (6) K - SI, (7) B - E, (8) BII - E, (9) B - E.

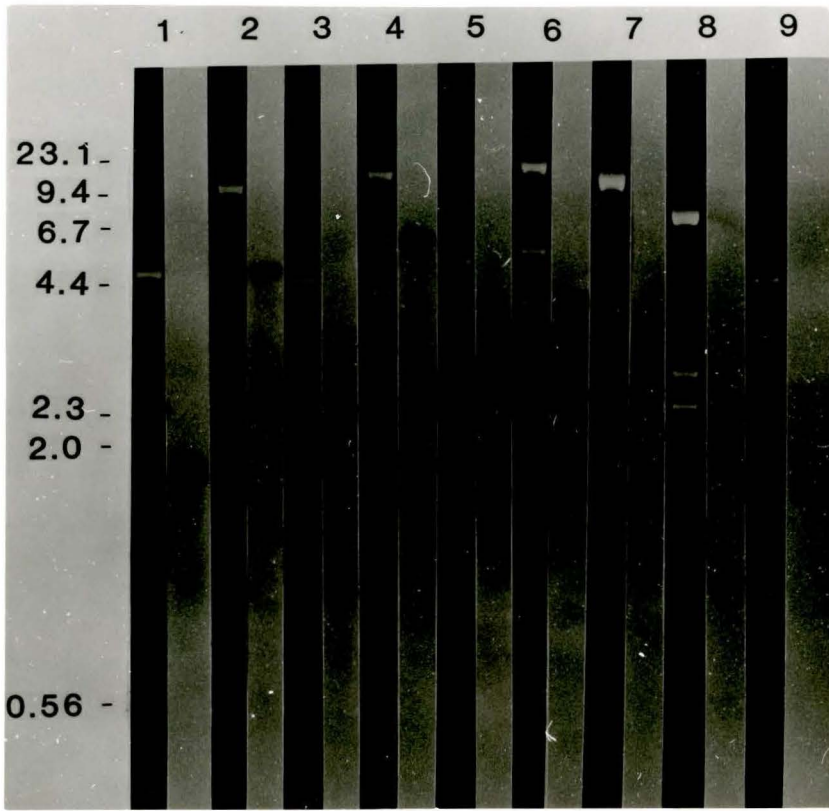



## DISCUSSION

In order to gain a better understanding of the mutant phenotypes of rem1, we have examined interactions between the hyper-rec mutation and mutations in excision-repair and recombination-repair. Initially, we examined the recombination-repair group of functions to determine if rem1 recombination is similar to spontaneous mitotic recombination between homologs in requiring RAD52 (74,140,186). Since rem1 rad52 and rem1 rad50 double mutants are inviable (Table 19 and reference 143), we could not ask that question. However, in part because of the double mutant inviability, we have proposed that recombinogenic lesions occur in rem1 strains which at least sometimes requires resolution by the double-strand break repair epistasis group (143). If the rem1 mutations lead to the direct production of a double-strand break, it is not entirely clear how this could lead to the joint stimulation of recombination and mutation. A direct double-strand break need not be mutagenic and the act of recombination itself is not believed to be mutagenic. Therefore, a simple model for the action of the rem1 mutation is that lesions occur in rem1 strains which require cellular processing for the observed stimulation of recombination and mutation. Considering the diverse signals that elicit an excision-repair response in yeast [ie. pyrimidine dimers, psoralen cross-links, and N-6-methyladenine (5,9,90,175)], we have examined the excision-re-

pair functions RAD1 and RAD4 (202,203) to determine if these have a role in rem1 hyper-recombination by responding to a rem1 DNA lesion.

The rad1-2 and rad4 mutations specifically reduce rem1 hyper-gene conversion but not hyper-crossing-over (Table 17). Functionally, these experiments demonstrate that RAD1 and RAD4 are extragenic suppressors of rem1 gene conversion. Since rem1 stocks require recombination-repair functions for viability and, as demonstrated, excision-repair for increased gene conversion, we asked if these two sets of interactions are inter-related. Specifically, we wished to know if excision-repair functions act on an initial rem1 DNA lesion. Our approach was to determine if the excision-repair mutations "rescue" double mutant inviability and allow strains such as rem1 rad52 to survive. Of the eight possible segregation classes for triply heterozygous diploids, only the expected double mutants containing recombination-repair and rem1 mutations are inviable (Table 19). All other segregation classes, including the predicted viable triple mutants, are observed. One interpretation is that the initial rem1 DNA lesion is not processed into a recombinogenic signal, such as a double-strand break, requiring recombination-repair functions.

The viability of triple mutants allowed us to examine the levels of recombination in these stocks. Since current molecular models for recombination propose an association

between conversion and crossing-over (50,63,155,239), and rad52-1 confers a mitotic Rec<sup>-</sup> phenotype for homologous inter- and intragenic recombination (74,140,186), triple mutants like rem1 rad1 rad52 should demonstrate rad52 (ie. reduced) levels of conversion and crossing-over if rem1 hyper-recombination is entirely dependent on RAD52. As shown in Table 20, triple mutants demonstrate approximately single mutant (ie. rad52) levels of gene conversion, but are apparently increased for crossing-over. This observation is complicated by the fact that Rad52<sup>-</sup> cells have increased levels of chromosome loss. At this time we do not know whether all drug-resistant colonies occurring in the triple mutants are cross-overs, arising independent of the recombination-repair system, or if the high levels represent chromosome loss. Most likely, the drug-resistant population in triple mutants will comprise both cross-over and chromosome loss events. The interpretation of recombination levels in rad50-containing strains is difficult as rad50 itself is hyper-rec (139,145). However, the rad52 levels in triple mutants do fit the prediction that gene conversion should be generally reduced.

Figure 17 is an interpretation of the interactions described in this report. We propose that strains containing rem1 have a DNA lesion, indicated as "X", which can stimulate recombination and mutation. We feel there are alternative routes by which the DNA lesion is processed.

Figure 17 Model for interactions between rem1 and various repair mutations leading to the production of gene conversions, cross-overs, and mutations. Salient points regarding the generation of the model are given in the text.

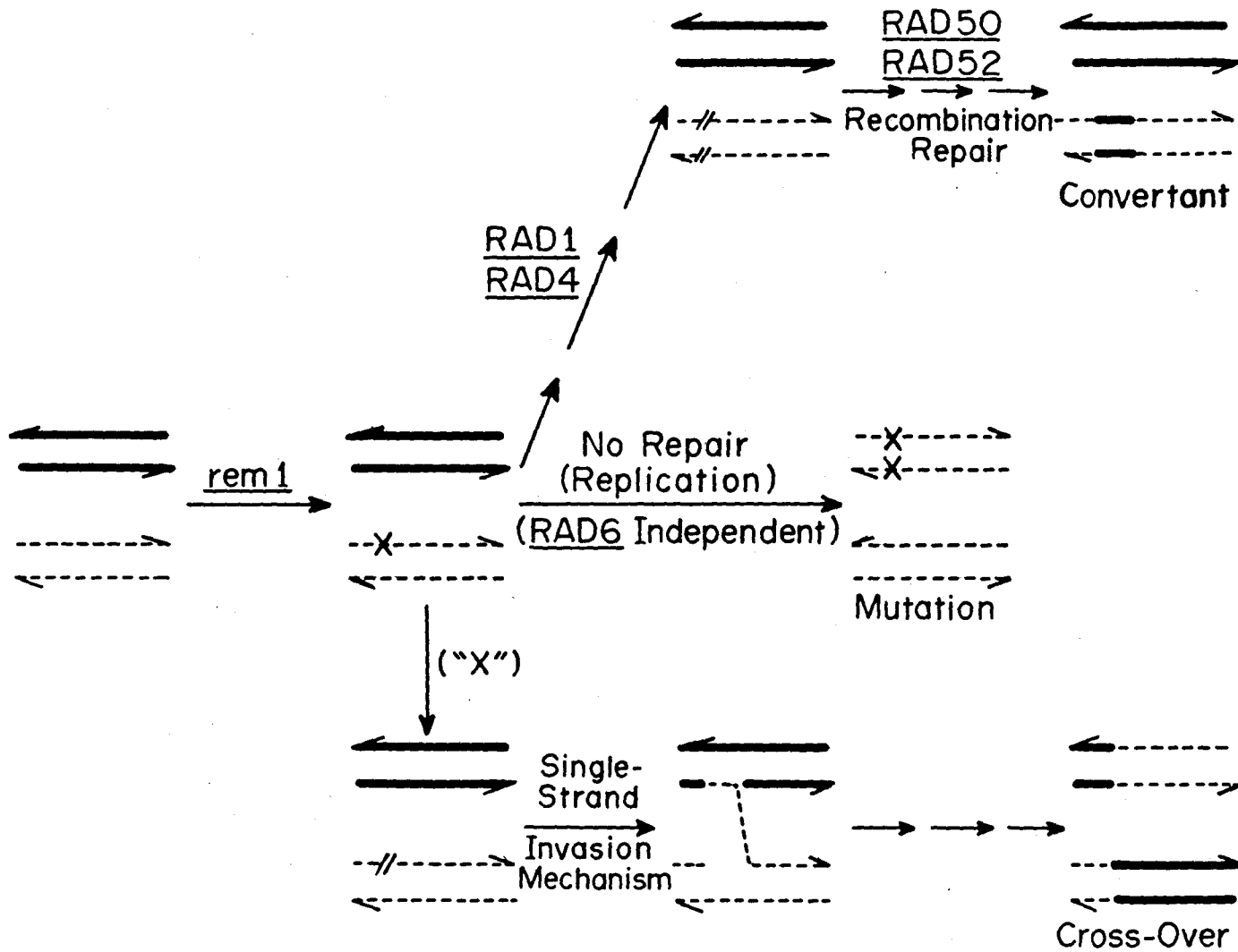

depending upon the route, different outcomes are observed. As indicated in Figure 17, the rem1 DNA lesion is recognized and acted upon at least by the RAD1 and RAD4 products. (The actual number and nature of the steps are not known and have been designated by three arrows). In the absence of these functions we presume the recombinogenic lesion for gene conversion (ie. the double-strand break) is not formed and triple mutants can survive. By determining the levels of recombination in triple mutants, gene conversion and crossing-over appear to be separable. If all rem1 recombination proceeds by RAD1 and RAD4 gene products, one might predict from molecular models that conversion and crossing-over would be affected similarly -- either both increased, both decreased, or both unaffected. However, we find that rem1 gene conversion can be specifically reduced by the mutations in excision-repair functions. We therefore propose that rem1 DNA lesions can undergo conversion and crossing-over events by alternative mechanisms. Since rem1 conversion is reduced by rad1 and rad4 (Table 17), and these mutations rescue double mutant inviability (Table 19), we believe it likely that rem1-created gene conversion proceeds by the RAD52 recombination-repair group of functions, presumably initiated by a double-strand break. However, since crossing-over is elevated in these strains, we feel it proceeds through a non-double-strand break, RAD52-independent mechanism such as a single-strand invasion. If the drug-re-

sistance frequency in triple mutant strains like rem1 rad1 rad52 is due to crossing-over and not chromosome loss, this would support the notion that rem1 hyper-crossing-over can proceed by a RAD52-independent mechanism. Some cross-overs may normally occur via a RAD52-dependent double-strand break mechanism as well. In Figure 17, we have proposed a simplified single-strand invasion model (155) as the mechanism for generating cross-overs in the absence of rad1 or rad4. Whatever the actual mechanism, we feel it is highly unlikely that the mechanism is based upon double-strand breaks given the genetic observations described earlier. It must be emphasized, however, that not all conversion or crossing-over need be entirely restricted to one mechanism or the other.

We have previously shown that mutations can occur at rem1 levels in rem1 rad6-1 strains (Chapter 3 and reference 105). That is, rem1 hyper-mutability is observed in the absence of the RAD6 error-prone repair function. We have interpreted this to mean that rem1 DNA lesions mimic spontaneous mutation in avoiding the requirement for a repair system (105). Thus, we have proposed the rem1 DNA lesion becomes a mutation in the absence of RAD6 by simple replication (Figure 17).

While constructing rem1 rad4 strains, we noted linkage between these loci. Further attempts at mapping rem1 with RAD3 demonstrated REM1 to be inseparable from RAD3. To find

out if the rem1 mutations are alleles of RAD3, we cloned RAD3 by complementing for rad3-2 UV-sensitivity and determined whether the clone complemented rem1 phenotypes. The plasmid pMFH100 is able to complement rem1-1, rem1-2, and rad3-2 phenotypes (Figures 14 and 15 and Tables 22 and 23).

A verified RAD3 clone (166) also complements rem1 hyper-recombination (Table 22) and an internal portion of RAD3 specifically hybridizes to a 3.9 Kb KpnI - SalI fragment which we have determined to contain the rem1 hyper-recombination complementing activity. Therefore, on the basis of these experiments, we feel that the rem1 mutations are alleles of RAD3 and wish to propose new names for the rem1 mutations. In order to avoid duplicate allele numbers with other rad3 mutations, we propose rem1-1 renamed as rad3-101 and rem1-2 as rad3-102.

Why was the identity of the rem1 mutations not discovered earlier? The most striking differences between rem1 alleles and currently known rad3 mutations are that: i) rem1 strains are almost as UV resistant as wild type (Chapter 4 and reference 105); ii) rem1 strains are hyper-rec and hyper-mutable (Table 17 and reference 141) while rad3-2 strains demonstrate essentially wild type levels (Chapter 8); and iii) rem1 alleles are inviable with rad50 and rad52 while rad3 alleles, like rad3-2, are viable (Chapter 8 and reference 71). The RAD3 gene is an essential mitotic function (99,167) involved in the pre-incision step of excision-



repair (202,203). Two groups, other than ourselves, have cloned RAD3. Both found that a truncated clone, lacking as much as 74 nucleotides at the 3' end of the coding region, conferred normal levels of UV resistance to rad3 mutants when present on a multicopy plasmid and complemented the RAD3 function essential for haploid viability (99,165-167). Unfortunately, neither group has analyzed the recombination properties of the truncated product. However, the possibility exists that the rem1 mutations may reside within the 3' end. We currently are attempting to clone the rem1-1 and rem1-2 alleles to determine their location for structure-function analysis. Detailed mutational analysis of the RAD3 gene should provide more specific information about the regions involved in excision-repair and mitotic recombination as well as the essential role RAD3 plays in mitosis.

## CHAPTER V

### PROPERTIES OF SPONTANEOUS MITOTIC RECOMBINATION OCCURRING IN THE PRESENCE OF THE rad52-1 MUTATION OF Saccharomyces cerevisiae<sup>4</sup>

#### Summary

All major recombination pathways in Saccharomyces cerevisiae require the RAD52 gene product. We have examined the effect of rad52-1 on spontaneous mitotic recombination between heteroalleles, and have found that heteroalleles are produced significantly above reversion levels. This residual recombination occurs at a relatively uniform level, at all heteroallelic loci examined. To help understand the role RAD52 plays in mitotic recombination, we examined recombination between six alleles of the LYS2 gene. The rad52-1 mutation decreases variation between the different heteroallelic pairs. The pattern of recombination also changes from wild type cells. This suggests the RAD52 gene product may play a role in the formation or correction of mismatches in a heteroduplex.

<sup>4</sup> M. F. Hoekstra, T. Naughton, and R. E. Malone, 1986. Genetical Research (Camb.) (submitted)

## INTRODUCTION

The RAD52 gene is apparently required for almost all types of genetic recombination in Saccharomyces cerevisiae. The rad52-1 allele, isolated as an X-ray sensitive mutation, is pleiotropic and confers a variety of mutant phenotypes (reviewed in 71 and 96). It is deficient in meiotic recombination at all loci on all chromosomes examined (74,186). As expected for a meiotic Rec<sup>-</sup> mutation, all spores formed following meiosis are inviable and do not germinate. The rad52-1 allele also confers a Rec<sup>-</sup> phenotype for spontaneous mitotic recombination (74,140,186). All current data support the contention that mitotic gene conversion is greatly reduced in rad52-1-containing strains. Consistent with this is the deficiency conferred by rad52-1 for the switching of mating types in homothallic strains (140). The effect of rad52-1 on spontaneous mitotic crossing-over is less defined. Malone (139) and Malone and Esposito (140) found that recombinants formed by cross-overs between homologous chromosomes were reduced 5 - 10 fold. Jackson and Fink (110), however, found that intrachromosomal reciprocal events at a his4 duplication were not reduced. Likewise, Prakash and Taillon-Miller (185), as well as Zamb and Petes (263), found that rad52-1 did not inhibit sister-strand crossing-over. Orr-Weaver et al. (172) examined the integration of non-replicating plasmids and argued that the relative frequency of integration was not reduced in rad52-1

strains. Since a reciprocal cross-over is required to insert a circular plasmid into a chromosome, their suggestion was that rad52-1 did not affect mitotic crossing-over.

More recently, Haber and Hearn (88) examined spontaneous mitotic recombination between the his4 heteroalleles used by Jackson and Fink (110). However, Haber and Hearn examined MATa/MAT $\alpha$  diploid recombination occurring between homologs with easily detectable outside markers, rather than at a duplication in haploids. They found that 84% of the events generating His<sup>+</sup> prototrophs in rad52-1 strains were associated with exchange of outside markers. This is in contrast to 23% in Rad<sup>+</sup> cells. The events producing His<sup>+</sup> prototrophs were conversions; Haber and Hearn did not detect the reciprocal double his4 mutant. They concluded gene conversion did occur in the absence of RAD52 and observed the properties were markedly different than conversions occurring in wild type cells. Not only was conversion often associated with exchange, but the pattern was different. On the basis of their observations, Haber and Hearn argued that the majority of gene conversion events in rad52-1 cells occurred by the formation of DNA heteroduplexes and mismatch repair.

We have been interested in the role RAD52 plays in spontaneous mitotic recombination. We observed the frequencies of prototroph formation at different loci examined by Malone and Esposito for gene conversion were remarkably

similar. If prototrophs were due to recombination, and not reversion, similar frequencies suggest the residual recombination occurring in the absence of RAD52 has different properties than recombination occurring in its presence. One way to generate a uniform recombination frequency at various heteroallelic pairs is for the process to no longer depend upon the distance between mutations, and all heteroduplex DNA treated identically. To examine this question we looked at recombination between several alleles at a single locus, LYS2. The data in this paper suggests the RAD52 gene product may play a role during spontaneous mitotic recombination in the formation and/or correction of mismatches.

## MATERIALS AND METHODS

### Strains

The relevant genotypes of S. cerevisiae strains are shown in Table 24. Strains were constructed by several backcrosses (at least three times) with wild-type laboratory strains in order to develop relatively isogenic backgrounds. Some of the strains used in backcrosses were K210-4A, K210-6D, K264-5B, and K264-10D (kindly supplied by Dr. S. Klapholz, University of Chicago). Standard techniques were used for sporulation, dissection, testing of auxotrophic requirements and prototrophic selection of diploids (143). All strains contained the ochre suppressible mutation ade2-1 and at least one other suppressible auxotrophy such as trp5-2, tyr1-1, or met13-c (94). These mutations were included to assay prototrophs arising from heteroalleles for the presence of suppressor mutations. The lys2-1 and lys2-2 alleles are ochre suppressible mutations. If  $Lys^+$  prototrophs occur by suppression rather than recombination, other ochre suppressible mutations can be co-suppressed and detected in a replica plate assay (142).

### Media

Media recipes have been previously described (80). Liquid medium (YPD) is 1% yeast extract, 2% Bactopectone and 2% dextrose. Solidified medium contains 1.8% Bactoagar (Difco). MMS plates, used to follow the segregation of

Table 24 Strain genotypes

	<u>lys2-1</u>	<u>lys2-2</u>	<u>lys2-500</u>	<u>lys2-501</u>	<u>lys2-502</u>	<u>lys2-503</u>
<u>lys2-1</u>	MH53 \ MH32	MH38	MH39	MH40	MH41	MH42
<u>lys2-2</u>	MH17	MH54 \ MH33	MH43	MH44	MH45	MH46
<u>lys2-500</u>	MH18	MH22	MH55 \ MH34	MH47	MH48	MH49
<u>lys2-501</u>	MH19	MH23	MH26	MH56 \ MH35	MH50	MH51
<u>lys2-502</u>	MH20	MH24	MH27	MH29	MH57 \ MH36	MH52
<u>lys2-503</u>	MH21	MH25	MH28	MH30	MH31	MH58 \ MH37

The strains listed in the upper right-hand portion of the table are RAD52 diploids containing the lys2 alleles designated by following a path along a row and down a column. The left-hand lower portion below the diagonal lists rad52-1 diploid strains.

Table 24 (Continued)

Strain	Relevant Genotype
RM11-10D	a <u>tyr1-1 ura3-13 hom3 ade2-1</u> <u>met13-c cyh2<sup>R</sup> trp5-c leu1-c ade6</u>
RM13-128D	α <u>tyr1-1 can1<sup>R</sup> ura3-13 his1 ade2-1</u> <u>ade5 met13-c cyh2<sup>R</sup> trp5-c leu1-12</u>
RM13, RM15 and RM27	a <u>leu1-c trp5-c cyh2<sup>R</sup> met13-c</u> α <u>leu1-12 trp5-2 CYH2<sup>S</sup> met13-d</u>  <u>ura3-1 lys2-1 tyr1-2 his7-2 RAD52 ade2-1</u> <u>ura3-13 lys2-2 tyr1-1 his7-2 RAD52 ade2-1</u>
RM41 and RM42	a <u>leu1-c trp5-c cyh2<sup>R</sup> met13-c</u> α <u>leu1-12 trp5-2 CYH2<sup>S</sup> met13-d</u>  <u>ura3-1 lys2-1 tyr1-2 his7-2 rad52-1 ade2-1</u> <u>ura3-13 lys2-2 tyr1-1 his7-1 rad52-1 ade2-1</u>
MH32	a <u>rad52-1 lys2-1 tyr1-1 his7-2 ura3-13</u> α <u>rad52-1 lys2-1 tyr1-1 his7-2 ura3-13</u>  <u>trp5-2 leu1-12</u> <u>trp5-2 leu1-12</u>
MH33	a <u>rad52-1 lys2-2 tyr1-2 his7-1 ura3-1</u> α <u>rad52-1 lys2-2 tyr1-2 his7-1 ura3-1</u>  <u>trp5-c leu1-c</u> <u>trp5-c leu1-c</u>



rad52-1, are YPD medium containing 0.01% Methyl-methane-sulfonate (Eastman Kodak). Strains containing rad52-1 are MMS sensitive.

#### Isolation of lys2 mutations

Mutations in the LYS2 gene were selected using a modification of the procedure of Chattoo et al. (27). Wild type strains RM11-10D and RM13-128D were each inoculated into 40 ml of YPD and grown overnight to a titre of  $2 \times 10^7$  cells/ml (mid-exponential phase). Cells were pelleted and washed twice in sterile 0.2 M sodium phosphate buffer (pH 7.5), re-suspended in 5 ml of phosphate buffer and 50 microliters of Ethyl-methane-sulfonate (EMS, Eastman Kodak) added. The suspension was held at  $24^{\circ}$  C for 45 minutes (corresponding to 81% survival). Preliminary EMS mutagenesis experiments indicated that this regimen generated a two log increase in forward mutation at CAN1. For the isolation of lys2 mutations, aliquots of mutagenized cells were spread on supplemented minimal media containing 4 mg/ml  $\alpha$ -aminoadipate ( $\alpha$ -AA). Prior to EMS treatment, the cultures demonstrated a spontaneous  $\alpha$ -AA resistance frequency of  $4.3 \times 10^{-6}$ . After EMS treatment, the frequency of resistance rose to  $6.2 \times 10^{-4}$ .

Approximately 600  $\alpha$ -AA resistant colonies were picked to master plates and tested for their ability to grow on lysine omission medium. Concomitantly, these isolates were subjected to lys2 complementation and allelism tests

against known lys2-1 and lys2-2 mutations. Isolates that were unable to grow without added lysine, did not complement known lys2 mutations but were able to undergo meiotic allelic recombination with both lys2-1 and lys2-2 were repicked to new master plates (44 isolates). Twenty-seven of these were in RM11-10D background and 17 in RM13-128D.

All possible pairwise crosses were done, with diploids being selected on medium without homoserine or histidine. Diploids were subsequently replicated to lysine omission medium and the number of Lys<sup>+</sup> papillae counted. A wide range of responses varying from a few to several hundred papillae per one cm<sup>2</sup> diploid patch was observed. Eleven RM11-10D and eight RM13-128D isolates from the pairwise crosses were chosen to pursue further.

The 19 isolates were backcrossed with unmutagenized wild type strains to remove the new lys2 mutations from the mutagenized background. The diploids were sporulated, dissected and lys2 mutations of both mating-types isolated. Four lys2 alleles which, when intercrossed, gave a wide range of mitotic papillation frequencies and demonstrated no papillae when homozygous were chosen, along with lys2-1 and lys2-2, for subsequent use. These strains were subjected to two further clean-up backcrosses before being outcrossed to rad52-1 strains. Following the recommendation of Dr. J. K. Bhattacharjee (Miami University of Ohio), we have named the isolates lys2-500, lys2-501, lys2-502 and lys2-503 (using an

allele numbering scheme of Chattoo et al., 27).

#### Determination of mitotic recombination levels

The procedure for determining mitotic recombination values is essentially as described by Malone and Hoekstra (143). Single colonies from freshly constructed diploids were picked into 1 ml of YPD and cell concentration determined by hemocytometer count. Ten ml of YPD was inoculated with  $10^4$  cells and the culture grown at  $30^{\circ}$  C with vigorous shaking to approximately  $2 \times 10^7$  cells per ml. Each culture was initiated from an independent colony and for all diploids at least three (most often 6 to 10) cultures were measured. After harvesting by centrifugation, cells were washed twice in sterile phosphate buffer, sonicated briefly to disrupt clumps and plated on lysine omission and complete synthetic media. Plates were scored after three days of growth at  $30^{\circ}$  C.

#### DNA blot analysis

The procedure for small scale isolation of total yeast genomic DNA has been described (105). DNA blotting, nick-translation and hybridization conditions are as described by Hoekstra and Malone (103).

## RESULTS

### Prototrophs produced at heteroallelic loci in rad52-1 are not due to reversion

Malone and Esposito (140) demonstrated that mitotic inter- and intragenic recombination between homologs in rad52-1 strains was reduced compared to RAD52 at all loci examined. Close examination of data published by Malone and Esposito reveals recombination frequencies for various heteroallelic loci ranging from  $1.0 \times 10^{-7}$  to  $6.9 \times 10^{-7}$  (Figure 18). The greatest variation between any of the heteroalleles in rad52-1 is only a 6.9 fold difference in recombination frequency (LEU1 versus TYR1). Compared to this relatively low range of fluctuation between loci, RAD52 strains had recombination frequencies ranging from  $2.9 \times 10^{-6}$  to  $7.5 \times 10^{-5}$  (HIS7 versus LEU1). This is approximately a 26 fold difference. The RAD52 recombination frequencies (Figure 18) are taken from the larger data set described by Malone and Hoekstra (143). The data used include those described by Malone and Esposito (140). In addition to the general suppression of intragenic recombination and the relatively uniform amount of heteroallelic recombination in rad52-1, the variations that occur have a pattern different from RAD52 strains.

It was necessary to demonstrate prototrophic colonies arising in rad52-1 homozygous diploids from heteroallelic loci were recombinants rather than revertants. Reversion

Figure 18 Recombination and mutation frequencies at various loci in RAD52 and rad52-1 strains. Geometric mean recombination and reversion frequencies for strains RM13, RM15, RM27, RM41, RM42, MH32, and MH33 are presented. The Rad<sup>+</sup> values are from Malone and Hoekstra (143), rad52-1 frequencies are from Malone and Esposito (140), and rad52-1 reversion frequencies are from this work.

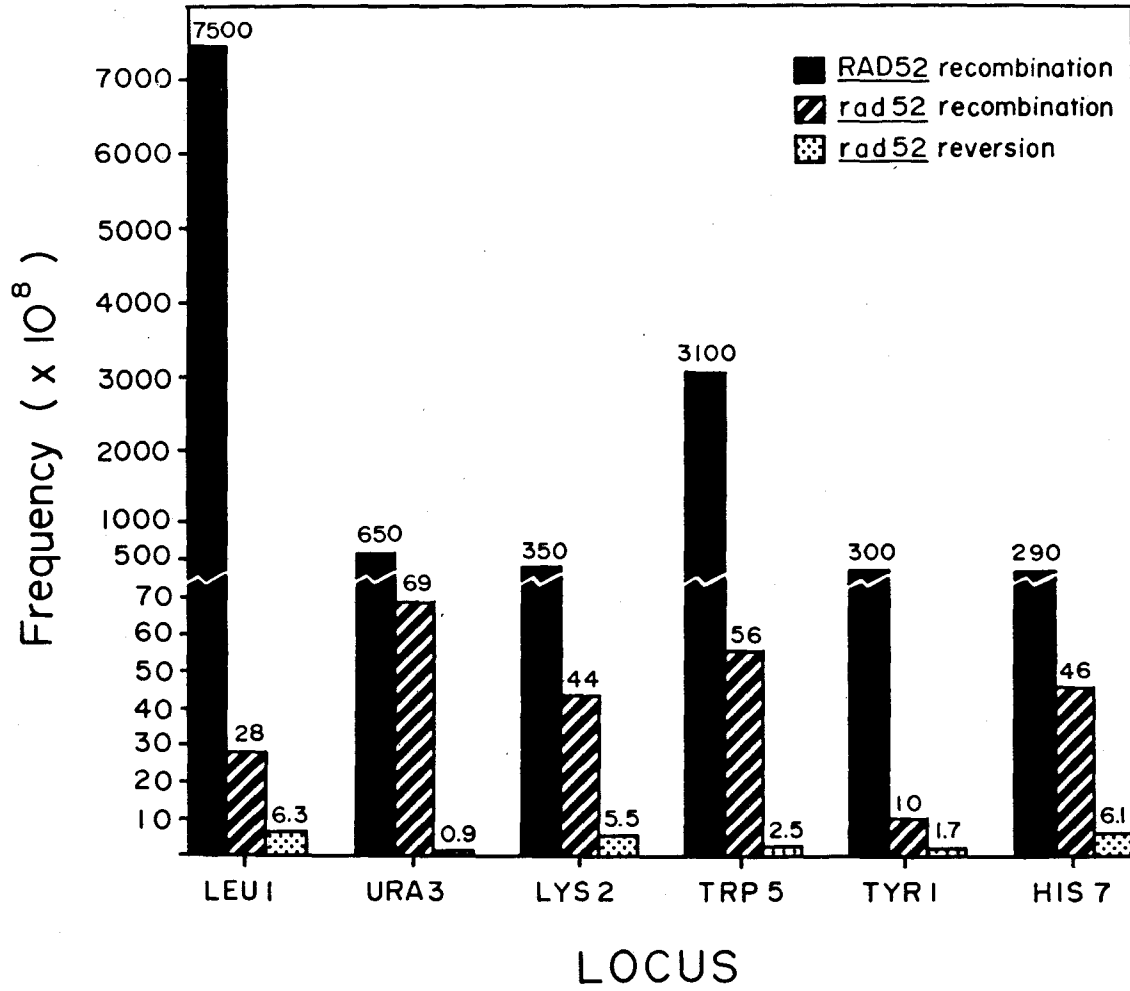

frequencies for the auxotrophic alleles present in the rad52-1 strains used by Malone and Esposito were measured in homoallelic diploids. As shown in Figure 18, the frequency of recombination in the rad52-1 background averages almost 10 fold greater than the combined reversion frequency for both input alleles comprising a given heteroallelic pair. In other words, heteroallelic intragenic mitotic recombination (gene conversion) in rad52-1 strains does occur and the level of recombination is almost ten times greater than mutation. On the basis of these observations, we feel there is low level recombination occurring in rad52-1 strains of Saccharomyces cerevisiae. The recombination events display a more uniform distribution than those occurring in wild type strains.

#### Isolation and characterization of lys2 mutations

Because the heteroalleles examined in Figure 18 are in different genes on different chromosomes, at varying distances from chromosomal landmarks (centromeres and telomeres, for example), we felt it necessary to carefully examine a set of mutations along a defined genetic interval. The fluctuation from locus to locus in RAD52 could reflect different probabilities of recombination occurring at a locus, rather than the recombination mechanism itself. If so, the homogeneous reduction in rad52-1 may only represent a uniform probability of initiation at all loci. This hypothesis is opposed to one proposing a distance and hetero-

duplex independence in rad52-1 strains. To determine whether the observed uniformity reflects events occurring within a locus, rather than being dependent on recognition of loci per se, we examined recombination between several alleles of the LYS2 gene.

LYS2 mutations, defective in  $\alpha$ -amino adipate reductase, were selected on the basis of resistance to  $\alpha$ -AA in the absence of lysine (27). From initial characterization, a set of six alleles (lys2-1, lys2-2, lys2-500, lys2-501, lys2-502 and lys2-503) were chosen for use in precise measurements of recombination levels. The criteria for choosing these alleles was: i) intercrosses of the isolates creating heteroallelic diploids gave a wide range of Lys<sup>+</sup> papillae in Rad<sup>+</sup> cells; and ii) sibling crosses, creating homozygous lys2 diploids, gave no revertant colonies in a simple replica plate assay. For the four alleles isolated, formation of Lys<sup>+</sup> revertants by this replica plate assay was undetectable, indicating that the levels of reversion and suppression for these alleles would not significantly affect our analysis in wild type strains. UV-induced mitotic recombination and meiotic recombination experiments using all pairwise combinations of the 6 lys2 alleles were consistent with their being located at different positions along the LYS2 gene (data not shown).

Although the four mutations generated for this study are EMS-induced and likely to be single base pair changes,



we examined the LYS2 genomic region for gross structural changes (such as deletions or insertions). (The LYS2-containing plasmid, p1-L13, was kindly supplied by Carl Falco, E. I. DuPont deNemours and Co., Wilmington, Delaware.) Our reasoning for examining the mutations by Southern blot analysis is based on the observation that a TY element insertion, such as the insert contained in ura3-52, can stimulate recombination 10 - 20 fold (M. F. H. and R. E. M., unpublished observation). A Southern blot and restriction map of the LYS2 region of p1-L13 is given in Figure 19. Based on this analysis, we detect no gross DNA alterations in any of the six lys2 alleles.

Spontaneous mitotic recombination at lys2  
in RAD52 and rad52-1 backgrounds

Figure 20 shows a histogram representation of recombination levels for all 15 pairwise combinations of lys2 alleles in wild type strains. [Recombination frequencies, rather than rates, are presented in order to facilitate direct comparison to the work of Malone and Esposito (140).] As in Figure 18, relative recombination levels between heteroallelic pairs fluctuates greatly (1 way ANOVA  $F = 8.718$ , d.f. = 14,  $p < 0.001$ ). However, in this case, heteroalleles are confined to a small genetic interval and the variation in levels are more likely to reflect the mechanism of the exchange event occurring at LYS2 rather than the probability of the event occurring at the locus.

Figure 19 Southern analysis of lys2 mutations. Approximately 3  $\mu\text{g}$  of total yeast DNA was digested with BglII and run in 0.8% agarose overnight, blotted to nitrocellulose, and probed with an EcoRI - HindIII LYS2 fragment from pl-L13. The lys2 mutant alleles are given above lanes.

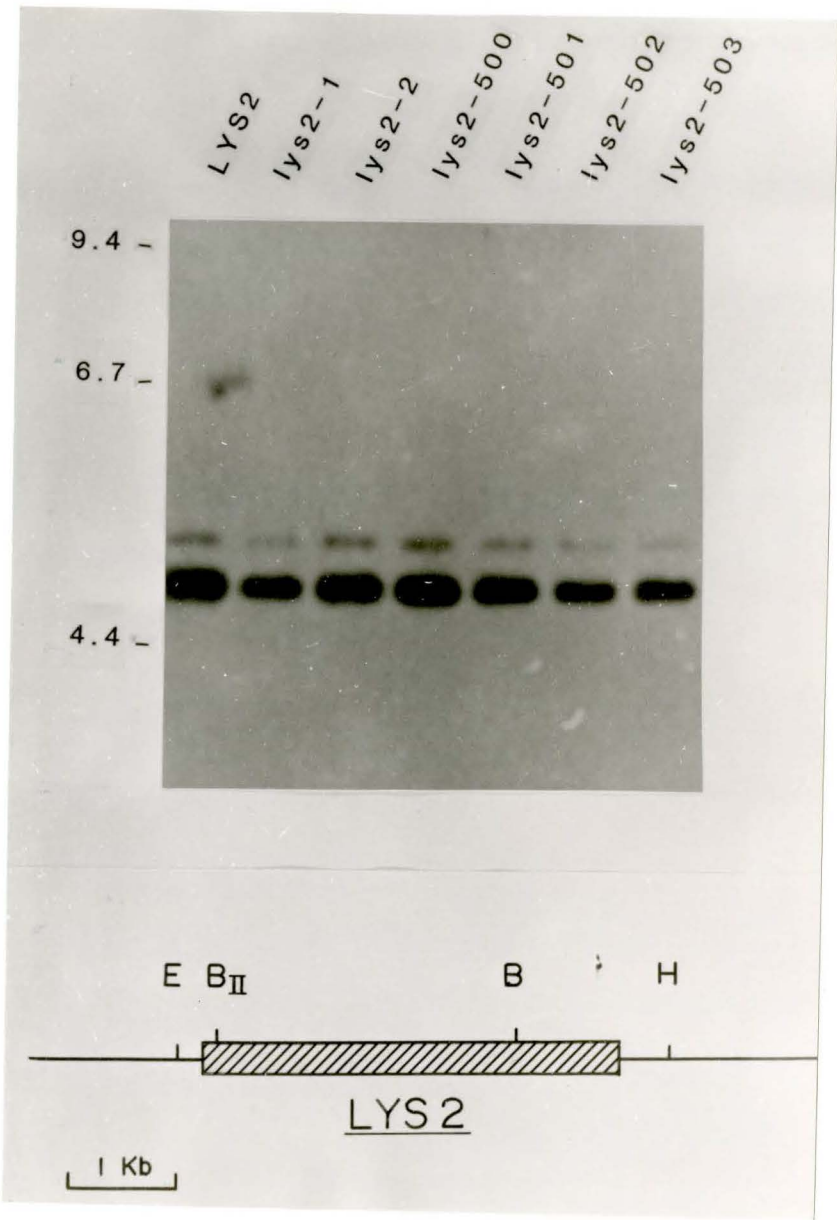
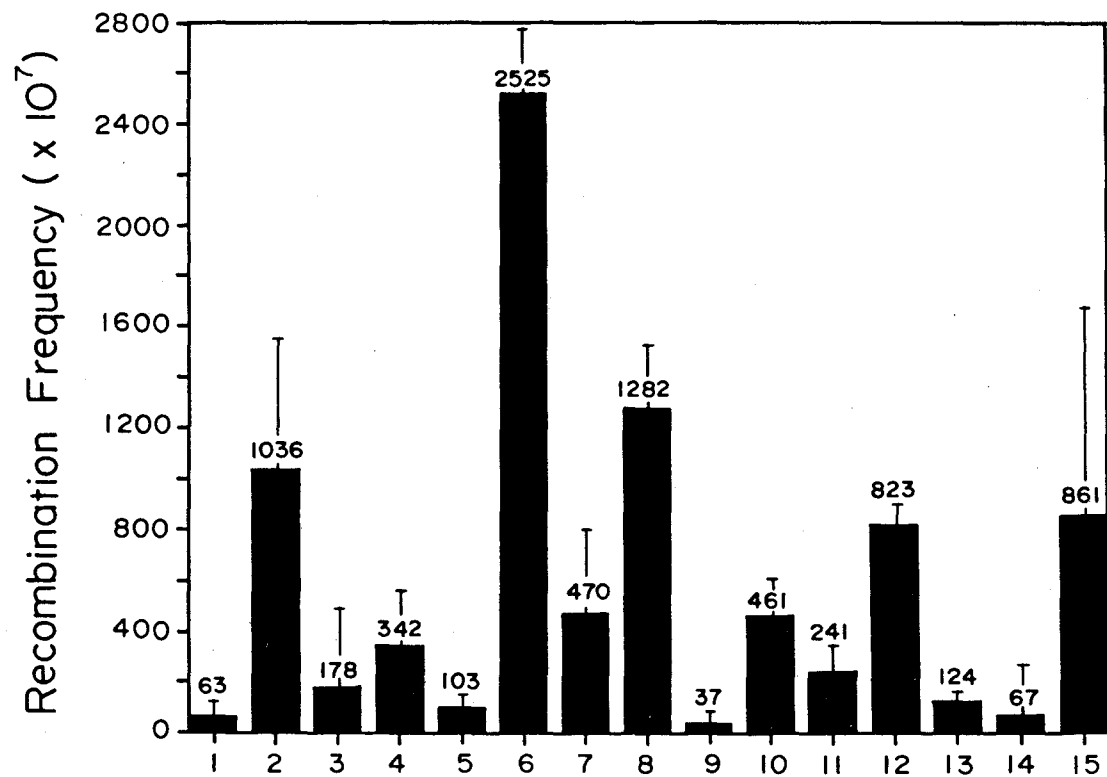

Figure 20 Spontaneous mitotic recombination at LYS2 in strains. The data represents geometric mean recombination frequencies for RAD52 strains at all pairwise combinations of the 6 lys2 alleles. Allelic pairs are as follows:

(1) lys2-1/lys2-2, (2) lys2-1/lys2-500, (3) lys2-1/lys2-501,  
(4) lys2-1/lys2-502, (5) lys2-1/lys2-503, (6) lys2-2/lys2-500,  
(7) lys2-2/lys2-501, (8) lys2-2/lys2-502, (9) lys2-2/lys2-503,  
(10) lys2-500/lys2-501, (11) lys2-500/lys2-502, (12) lys2-500/lys2-503,  
(13) lys2-501/lys2-502, (14) lys2-501/lys2-503, and  
(15) lys2-502/lys2-503. The actual strains used are listed in Table 24 (MH17 - MH30).



The largest difference in recombination frequencies is 69 fold (lys2-503/lys2-2 versus lys2-500/lys2-2) with a range of  $3.7 \times 10^{-6}$  to  $2.5 \times 10^{-4}$ . It should be noted that at least 50 to 100 Lys<sup>+</sup> colonies per culture were picked and retested in all experiments. This was done, in part, because lys2-1 and lys2-2 are ochre alleles, capable of being suppressed by tRNA mutations. Where necessary, corrections were made for suppression, but in most cases suppressors occurred in less than than 5 - 10 % of the putative recombinants in wild type strains. [All strains contained multiple diagnostic suppressible auxotrophic mutations (see Materials and Methods).]

Figure 21 represents the recombination frequencies for the same heteroalleles in Figure 20 in a rad52-1 background. (Note the scale differences between Figures 20 and 21.) For all heteroallelic pairs, the reduction in recombination frequencies in rad52 is of similar magnitude as observed in Figure 18. The decrease is comparable to the average reduction of approximately 10 - 50 fold reported by Prakash et al. (186) and Malone and Esposito (140). While there is a small variation between the geometric mean recombination frequencies given in Figure 21 ( $2.7 \times 10^{-7}$  vs.  $24.9 \times 10^{-7}$ ), almost all the recombination values are within one standard deviation of each other and the differences between each of the 15 pairwise combinations of lys2 mutations in the rad52-1 background is not apparently

Figure 21 Spontaneous mitotic recombination at LYS2 in rad52-1 strains. The data represents geometric mean recombination frequencies for all pairwise combinations of lys2 alleles. Allelic pairs are listed in Figure 20.

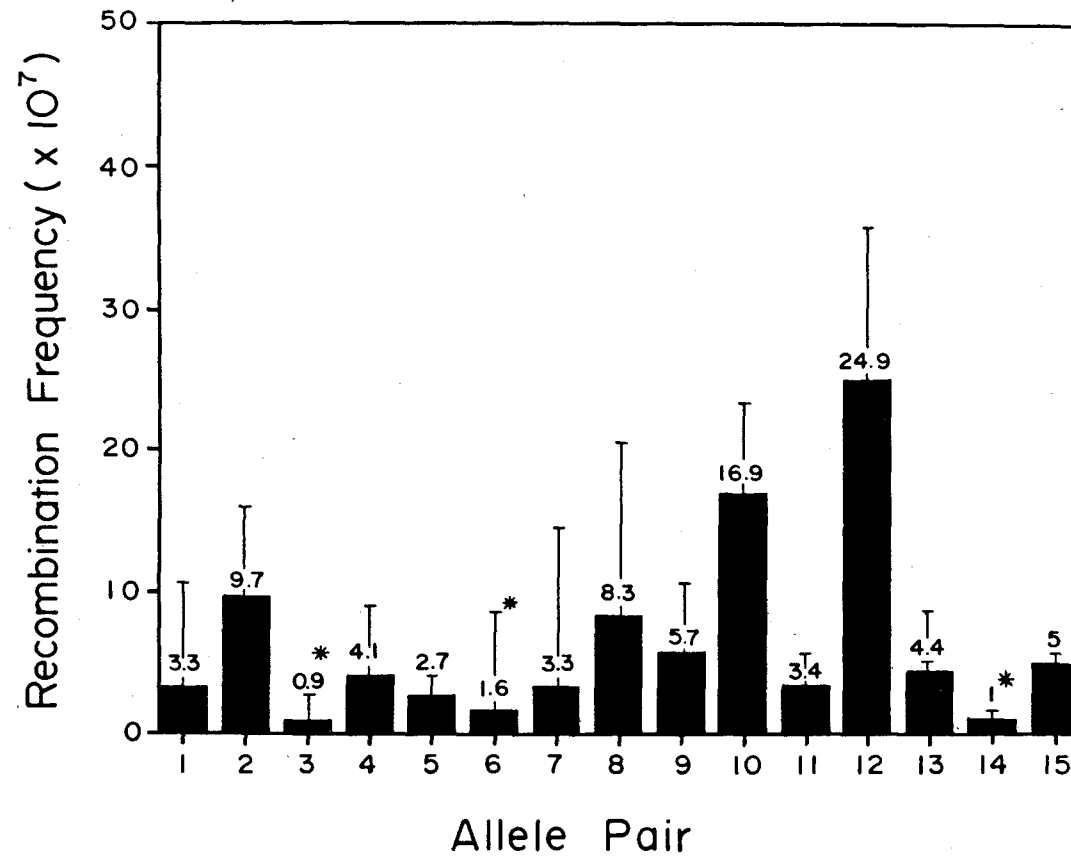



significant (1 way ANOVA  $F = 1.002$ , d.f. = 14,  $p = 0.462$ ). A similar statement cannot be made for the RAD52 data in Figure 20. Therefore, the recombination that occurs along the length of LYS2 in rad52-1 is relatively independent of the mutant allele present. It should be noted that 3 of the 15 heteroallelic pairs in the rad52-1 background demonstrate prototroph levels that are not much greater than reversion levels (these 3 are marked by an asterisks in Figure 21). Disregarding these 3 heteroallelic pairs, the largest difference in recombination frequencies for rad52-1 strains amongst the lys2 heteroalleles is 9.2 fold, a value similar to the 6.9 fold fluctuation observed by Malone and Esposito (140) for inter-locus comparisons.

Figure 22 is a histogram plot which directly compares the relative amount of recombination for a given heteroallelic pair in wild type versus rad52-1. To generate this comparative figure, we have taken the ratio of RAD52/rad52-1 recombination for a given heteroallelic pair and normalized the value to the lowest ratio, which has been given a value of one. This plot demonstrates that the spectrum of recombination in rad52-1 is drastically altered from wild type. If the heteroallelic pattern of recombination in rad52-1 were simply a reduction of the same distribution in wild type, then expected values for Figure 22 would be unity.

Evidence that the selected  $Lys^+$  colonies for each heteroallelic pair in rad52 mutants can be attributed to

Figure 22 Relative recombination at LYS2. The data is the ratio of mitotic recombination for RAD52/rad52-1 normalized to the lowest ratio (given a value of one). Allelic pairs are listed in Figure 20.

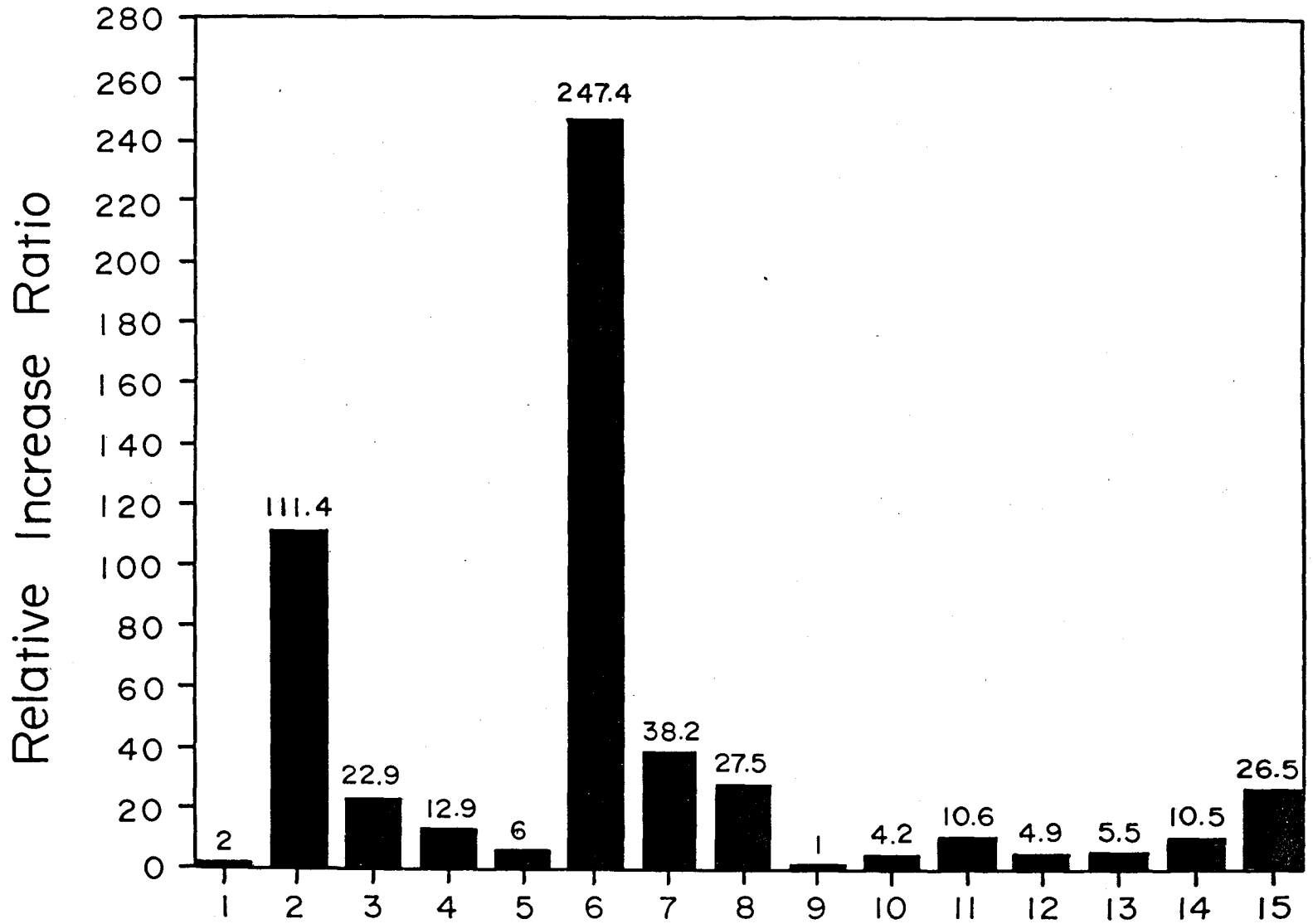

recombination is taken from the data in Table 25 and Figures 18, 20 and 21. In 12 of 15 cases, the level of prototrophs arising from a heteroallelic pair (Figures 20 and 21) is higher than the level of homoallelic reversion (Table 25) in the rad52-1 background. It is interesting to note that the occurrence of mutation in rad52-1 is elevated relative to wild type for four of the six alleles. There is approximately a five - ten fold average increase in reversion rates in rad52-1 strains. This agrees favourably with previous observations by Prakash *et al.* (186) that rad52-1 strains are slightly hyper-mutable. One interpretation for the increase in spontaneous mutation is that lesions which are normally processed by recombination-repair are channelled to another repair pathway, in this case potentially an error-prone pathway.

From the wild type mitotic recombination frequencies (Figure 20) we present a map of the LYS2 gene demonstrating relative positions of the 6 lys2 mutations examined (Figure 23). The best map order for the lys2 alleles appears to be: lys2-503, lys2-2, lys2-1, lys2-501, lys2-502, lys2-500. Precise alignment of these mutations on the LYS2 gene will require gap-rescue analysis (173) and/or nucleotide sequencing.

Table 25 Frequency of reversion to prototrophyREVERSION FREQUENCY X 10<sup>7</sup>

DIPLOID GENOTYPE	<u>lys2-1</u>	<u>lys2-2</u>	<u>lys2-500</u>	<u>lys2-501</u>	<u>lys2-502</u>	<u>lys2-503</u>
<u>rad52-1</u>	1.8	3.8	1.8	1.0	2.4	1.5
rad52-1	±2.6	±4.6	±2.1	±1.3	±0.8	±3.4
<u>RAD52</u>	0.1	1.3	0.3	2.4	0.1	3.4
RAD52	±0.02	±3.6	±0.9	±0.7	±0.8	±4.7

The data represents geometric mean reversion frequencies of 7 and 4 cultures per diploid for rad52-1 and RAD52 strains, respectively. The diploids used were MH32 - MH37 and MH53 - MH58.

Figure 23 Allele order of the LYS2 mutations. A consensus order of alleles along the LYS2 gene was determined from the geometric mean recombination frequencies for all pairwise combinations of lys2 mutations in a Rad<sup>+</sup> background.

# LYS 2

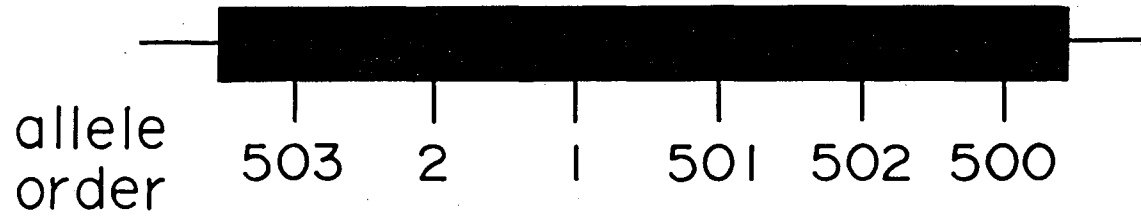

## DISCUSSION

In this report we have examined spontaneous, intragenic recombination in rad52-1 strains. The RAD52 gene product is one of the more interesting recombination and repair functions in yeast. Strains with mutations in RAD52 are X-ray sensitive and rad52-1 homozygous diploids exhibit drastically reduced frequencies of mitotic inter- and intragenic recombination between homologs (reviewed in 71). The rad52-1 mutation also confers a reduction in the recovery of viable recombinants after meiosis (74) and is defective in the production of physically recombined DNA through meiosis (13). The RAD52 gene has been cloned, sequenced and a conceptual translation of the coding region proposed (3,224,225). The gene could encode a 56 KDa protein. Interestingly, Resnick and coworkers have demonstrated that rad52 strains lack a 70 KDa endonuclease (28, 195,200), leading to the proposal that the RAD52 gene is a control function for the endonuclease. The rad52-1 allele has been sequenced by Adzuma et al. (3) and is a missense mutation at codon 90 of 504 codons. The rad52-1 allele appears to have similar properties for repair and meiotic recombination as does a gene disruption created by Schilds et al. (225). We conclude it is likely that strains containing rad52-1 have little functional gene product present.

The data presented here indicate a low level of



mitotic recombination occurs in rad52-1 mutant strains. Two hypotheses to explain this observation are: i) there is another recombination pathway in Rad52<sup>-</sup> cells, or ii) the rad52-1 mutant is leaky, and a small amount of functional RAD52 product is present. We favor the former hypothesis for three reasons. First, whenever tested, the properties of the rad52-1 mutation are similar to rad52 gene disruptions created in vitro and transplanted into the chromosome (225). Second, published data suggest, in some instances, recombination in the form of crossing-over can occur in rad52-1 strains (110,121,172,185,263). Third, if the rad52-1 mutation were leaky, the simplest expectation would be the rank order of heteroallelic pairs remains the same, although heteroallelic recombination level is reduced. In other words, frequencies would be reduced but the distribution would be the same. We note if the second hypothesis were true, the data indicates low levels of RAD52 gene product alter the mechanism of recombination events, not simply the frequency.

Examination of recombination in rad52-1 strains along a defined genetic interval, LYS2, has provided an interpretation for the original observations of Malone and Esposito (140). Recombination levels are greater than mutation levels for 12 of 15 heteroallelic pairs examined in this study and for all heteroalleles examined by Malone and Esposito (140). The levels of recombination in rad52-1

strains are relatively uniform compared to wild type. Comparison between heteroallelic recombination at loci on different chromosomes indicates there is only about a seven fold variation in frequencies. Recombination between different heteroalleles along a small genetic interval demonstrate at most a nine fold range in frequencies. Using the same pairs of heteroalleles, wild type strains show a 70 fold range in recombination frequencies. One interpretation of this observation is all heteroduplexes containing heteroallelic mismatches are formed with equal probability. Furthermore, each mismatch is repaired equivalently. This interpretation is based on a single-strand exchange mechanism as proposed by Meselson and Radding (156), rather than a double-strand break model (193,239). If a background RAD52-independent recombination system is generating the recombinants, it has very different properties than the RAD52-dependent system. Should a low level of the RAD52 product be present in these cells, the amount is affecting the mechanism of the event. Regardless, it suggests that RAD52 plays a role, directly or indirectly, in the formation and correction of mismatches.

How can a single mutation in a recombination-repair function lead to both a change in the level and the distribution of spontaneous mitotic gene conversion? If rad52-1 blocks the major mitotic recombination pathway, then any recombinants formed must occur by a secondary route. Owing to

its X-ray sensitivity (74,186), inability to perform mating type interconversion (140), and lack of gapped plasmid integration (172), the rad52-1 mutation is believed to inactivate a function involved in double-strand break repair (recombination-repair). If spontaneous mitotic recombination proceeds normally via a double-strand break mechanism, a cell attempting recombination by this route would be inviable in the absence of RAD52. Consistent with the proposal of Haber and Hearn (88), it seems that a RAD52-independent recombination pathway, as described above, might likely proceed by non-double-strand break mechanisms similar to those discussed by Meselson and Radding (156).

## CHAPTER VI

### EXPRESSION OF THE Escherichia coli dam METHYLASE GENE IN Saccharomyces cerevisiae: EFFECT OF IN VIVO ADENINE METHYLATION ON GENETIC RECOMBINATION AND MUTATION<sup>5</sup>

#### ABSTRACT

The Escherichia coli DNA adenine methylase (dam) gene has been introduced into Saccharomyces cerevisiae on a yeast - E. coli shuttle vector. Sau3AI, MboI, and DpnI restriction enzyme digests and Southern hybridization analysis indicated that dam gene is expressed in yeast cells and methylates GATC sequences. Analysis of digests of total genomic DNA indicated that some GATC sites are not sensitive to methylation. The failure to methylate may reflect an inaccessibility to the methylase due to chromosome structure. The effects of this in vivo methylation on the processes of recombination and mutation in mitotic cells were determined. A small but definite general increase was found in the frequency of mitotic recombination. A similar increase was observed for reversion of some auxotrophic markers; other markers demonstrated a small decrease in mutation frequency. The effects on mutation appear to be

<sup>5</sup> M. F. Hoekstra and R. E. Malone, 1985. Mol. Cell. Biol. 5:610-618.

measured and was not detectibly altered by the presence of 6-methyladenine in GATC sequences.

## INTRODUCTION

Methylation of DNA bases has been demonstrated to play an important role in the processes of DNA replication, repair, and recombination in procaryotes and gene expression in eucaryotes (2,40). In Escherichia coli a methyl group is added, after replication, to the N6 position of adenine in 5'-GATC-3' sequences by DNA adenine methylase produced by the dam gene (85,151). It has been proposed that the transient undermethylation of newly replicated strands allows a mismatch repair system to preferentially remove the new (incorrect) information when replication errors occur (78,190, 246). Recent experiments using heteroduplexes of phage lambda DNA, methylated in vitro and transformed into E. coli, have confirmed that the mismatched base on the undermethylated strand is preferentially repaired (189).

In E. coli, the consequences of losing the ability to methylate adenine are profound. The lack of methylation in dam<sup>-</sup> strains leads to increased frequencies of recombination and spontaneous mutation (7,150,151) and increased sensitivity to methyl methane sulfonate (152) and UV (150). Furthermore, the dam mutation is lethal in combination with recB/C or lexA mutations (7,152). All of these phenotypes can be understood in terms of the mismatch correction system being unable to distinguish which strand to attack when a mismatch is created during replication. Specifically, increased mutation could occur when the correct base was

removed, and increased recombination could result from single-strand gaps and breaks or from double-strand breaks generated when excision tracks on both DNA strands overlap (190). Overproduction of the dam enzyme also leads to increased mutation frequencies (98). Herman and Modrich argued that increased levels of the dam methylase would result in a DNA molecule (98) rapidly methylated after replication on both strands, producing fully methylated DNA resistant to mismatch repair (98). This is supported by the results of Pukkila et al. (189), which indicate that DNA fully methylated in vitro is not subjected to mismatch repair when transformed into E. coli.

The yeast Saccharomyces cerevisiae contains undetectable amounts of methylated adenine (<0.05%) (93). By using the same chromatographic technique, it was shown that the same approximately 1% of deoxycytosine in yeast DNA contained methyl groups at the 5' position (93). Recently, Proffitt et al. (188) have shown by high-pressure liquid chromatography and by Southern analysis that 5-methylcytosine is present at  $\leq 0.03\%$  of the cytosine residues in the endogenous yeast 2  $\mu$ m plasmid or in chromosomal DNA.

The dam gene in E. coli has been cloned and more recently inserted into a yeast-E. coli shuttle vector that can replicate in yeast cells (R. Kostriken, personal communication). Brooks et al. (15) state that the dam gene is expressed and methylates yeast DNA. We have modified the

original vector and transformed yeast strains with the cloned dam gene to confirm that it is expressed and to ask what effect adenine methylation has on recombination and mutation in S. cerevisiae. To our knowledge these are the first experiments to measure the effect of 6-methyladenine on recombination and mutation in eukaryotes.



## MATERIALS AND METHODS

### Strains and culture conditions

The strains used in this study are listed in Table 26. To monitor the effect of dam on recombination, the yeast diploid strain MH16 was constructed containing six heteroallelic loci and two recessive drug resistance loci. The former allow us to examine mitotic gene conversion and the latter to measure mitotic crossing-over (50). To examine the effect of dam on mutation, the transformed MH16 diploid was dissected by using standard techniques (49) generating the haploids MH16-4C, MH16-A10B, and MH16-B-24B with and without plasmid pMFH1 containing the dam gene (Table 26). All yeast media have been previously described (80). E. coli media are described in Maniatis et al. (144).

### Construction of pMFH1

To introduce an appropriate selectable marker into the dam-containing plasmid pRK99, pMFH1 was constructed. The construction scheme and plasmid maps are given in Figure 24. The 1.1 kilobase (kb) HindIII fragment containing the URA3 gene from YEp24 was introduced into the unique HindIII site of pRK99. The resulting plasmid pMFH1 was obtained by selecting for Leu<sup>+</sup> Ura<sup>+</sup> Amp<sup>r</sup> transformants of E. coli strain MC1006 (191) on minimal media containing tryptophan. Recombinant plasmids were isolated and subjected to HindIII - PvuII double digests for verification of the construct.

Table 26 List of strains

strain	Genotype
Yeast Strains <sup>a</sup>	
MH16	<u>O MATa O lys2-2 tyr1-2 his7-1 CAN1<sup>S</sup> ura3-1 O</u> <u>MAT<math>\alpha</math> lys2-1 tyr1-1 his7-2 can1<sup>R</sup> ura3-13</u> <u>+ met13-c cyh2<sup>R</sup> trp5-c leu1-c O O ade2-1</u> <u>ade5 met13-d CYH2<sup>S</sup> trp5-d leu1-12 ade2-1</u>
MH16-4C	<u>O MATa O lys2-2 tyr1-2 his7-2 CAN1<sup>S</sup> ura3-1 O</u> <u>ade5 met13-d cyh2<sup>R</sup> trp5-c leu1-c O O ade2-1</u>
MH16-A-10B	<u>O MAT O lys2-2 tyr1-1 his7-2 CAN1<sup>S</sup> ura3-1 O</u> <u>+ met13-d CYH2<sup>S</sup> trp5-c leu1-c O O ade2-1</u>
	Containing pMFH1
MH16-B-24B	<u>O MATa O lys2-2 tyr1-2 his7-2 CAN1<sup>S</sup> ura3-1 O</u> <u>ade5 met13-d CYH2<sup>S</sup> trp5-c leu1-c O O ade2-1</u>
	Containing pMFH1
Bacterial strain ( <u>E. coli</u> )	
MC1006	<u>hsdR hsdM<sup>+</sup> leuB6 lacx74 galU galK StrA<sup>R</sup> trpc9830</u> <u>pyrF</u>

The source of the yeast strains are from this work, MC1006 was kindly supplied by M. Casadaban.

<sup>a</sup>The circle represents the centromere and the line represents a chromosome linkage group. Gene symbols are defined by Plischke et al. (175).

Figure 24 Construction of pMFH1. The 1.1 Kb URA3 gene from YEp24 was introduced into pRK99 at the unique HindIII site to produce pMFH1. E refers to a restriction site for EcoRI; H, for HindIII; P, for PstI; and P<sub>II</sub> for PvuII. The heavy solid line is the 2  $\mu$ m origin of replication; the thin line is pBR322 sequences. The yeast URA3 gene and E. coli dam are indicated, and the checkered area is the yeast LEU2 gene. Only relevant restriction sites are shown.

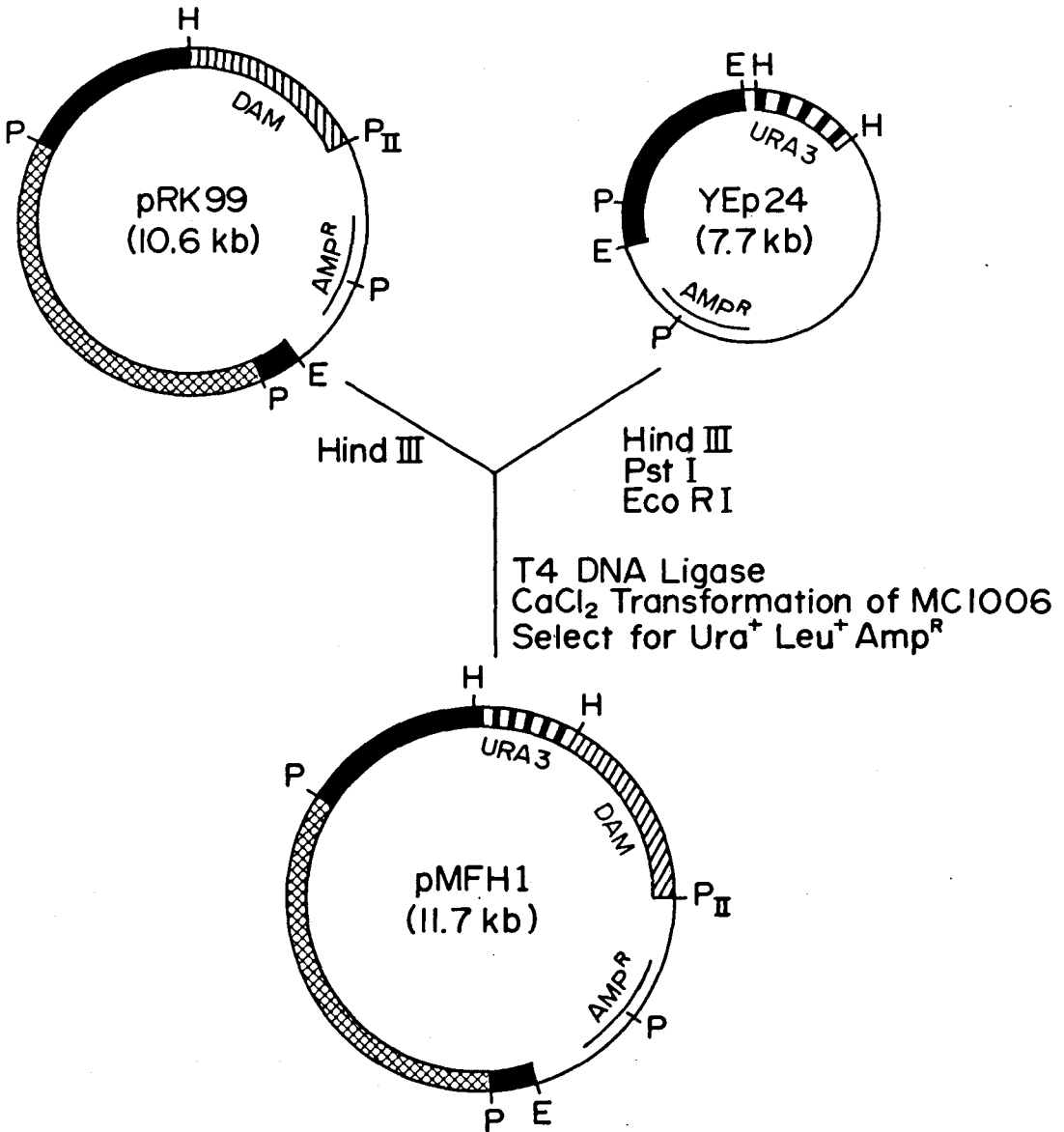

### Measurement of recombination and mutation frequency

The mitotic recombination frequency was measured as described in Malone and Hoekstra (143). Mutation frequencies were determined by using a similar approach except that the initial inoculum, as determined by hemocytometer count, was lower (100 cells per ml) and the cells were allowed to grow to mid-exponential phase (approximately  $5 \times 10^7$  cells per ml) before harvesting and plating on the appropriate media. The meiotic recombination analysis (see Table 28) results from standard tetrad analysis (162).

### Transformation, DNA purification, and hybridization analysis

The procedures for spheroplast transformation and DNA isolation from yeast cells have been previously described (100) and were used with minor modifications. Transformation of E. coli cells was mediated by  $\text{CaCl}_2$ , using standard protocols (147). In all experiments described, the yeast DNA has been  $\text{CsCl}$  purified and phenol extracted. Southern analysis (231) was carried out as previously described (144) except the gel was pretreated with 0.25 M HCL for 20 min before blotting to enhance transfer of larger DNA fragments. Transfer of DNA was judged to be complete by ethidium bromide stain of the gel. Prehybridizations and hybridizations were carried out in the presence of 5 x Denhardt reagent and the hybridization mix contained 5% dextran sulfate (248) (1 x Denhardt reagent is 0.02% each Ficoll

40,000, polyvinylpyrrolidone, and bovine serum albumin). Restriction enzymes were purchased from Bethesda Research Labs, Gaithersburg, Md., and New England Biolabs, Beverly, Mass., and were used as recommended by the vendors.

DNA fragments used as nick-translated probes were radiolabeled as described in Malone and Hyman (145). Before labeling, the fragments were purified from low-melting-temperature agarose (Bethesda Research Labs) by a procedure modified from Gafner et al. (70)

## RESULTS

### Expression of the *dam* gene in *S. cerevisiae*

The 1.1 Kb HindIII fragment containing the URA3 gene from YEp24 was inserted into the HindIII site of pRK99 (Fig. 24). The resulting plasmid, pMFH1, was used to transform the yeast diploid MH16 by selecting for URA<sup>+</sup> colonies. Plasmid pMFH1 contains the 2  $\mu$ m origin of DNA replication and is a relatively high-copy-number plasmid. To determine whether the E. coli *dam* gene product was capable of methylating adenine in GATC sequences in yeast cells. DNA from transformants was compared with DNA from the nontransformed parental strain. The restriction enzyme isoschizomers Sau3AI, MboI, and DpnI were used to compare the susceptibility of the various DNAs to digestion. Samples were taken after various times of digestion and examined by agarose gel electrophoresis. Figure 25A illustrates that DNA from a transformant containing the *dam* gene was refractory to cleavage by MboI; this enzyme will not cleave at GATC sequences containing 6-methyladenine (75). Sau3AI digested DNA from the transformant with similar kinetics and to a similar end product as it did the nontransformed parental DNA (Fig 26A). None of the DNAs was digested by Sau3AI to the same extent as the DNA from the nontransformed parent cleaved by MboI (see Discussion). The pertinent observation, however, is that Sau3AI digested both DNAs equally, whereas MboI was inhibited on the DNA from the

Figure 25 Illustration that yeast DNA from a dam (pMFH1) transformant is refractory to cleavage by MboI. From a reaction mixture containing 24  $\mu$ g of DNA and 20 U of MboI, four  $\mu$ g samples were removed at 15 (lanes 1 and 5), 30 (lanes 2 and 6), 60 (lanes 3 and 7), and 120 (lanes 4 and 8) min and run overnight at 30 mA constant current in a 1.5% agarose gel, using Tris-Borate-EDTA (144) as the running buffer. (A) Ethidium bromide-stained gel. (B) Southern blot probed with the 1.4 Kb EcoRI TRP1 DNA. In both (A) and (B), DNA in lanes 1 to 4 is from untransformed MH16, whereas lanes 5 to 8 contains samples from the corresponding pMFH1-containing dam transformant. The size standards were HindIII and AvaI digests of lambda DNA (not shown).



A

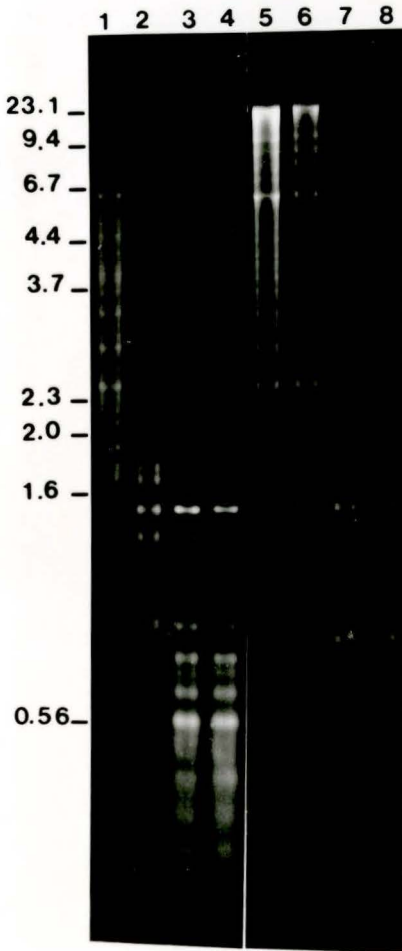

B

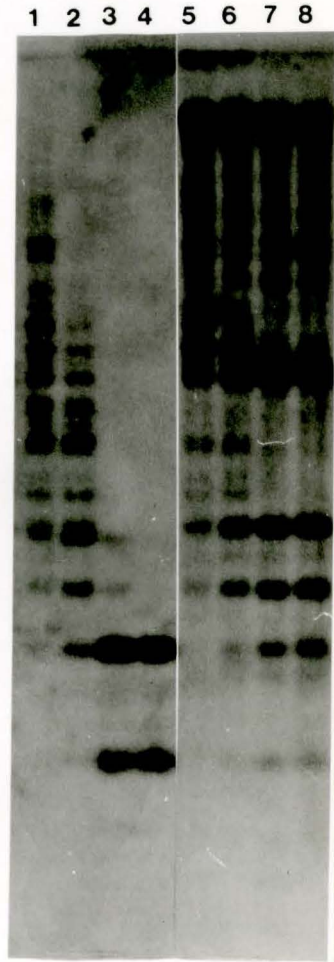
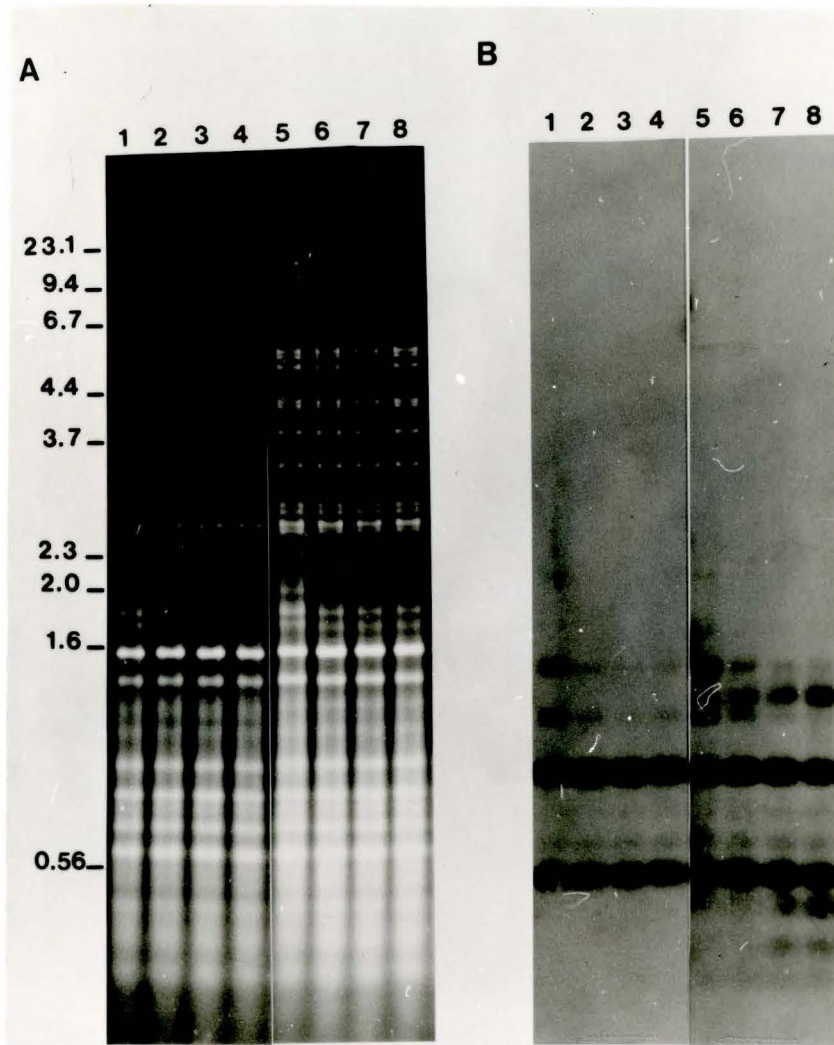

Figure 26 Illustration that methylated and nonmethylated yeast DNA is susceptible to Sau3AI digestion. Quantities of DNA, enzymes, sampling times, and size standards are as in Fig 25. (A) Ethidium bromide-stained gel. (B) Southern blot probed by TRP1 fragment. Lanes 1 to 4 contain parental DNA; lanes 5 to 8 contain DNA from pMFH1-transformed cells.



transformant containing the dam gene (Fig. 25A and 26A). This confirms that the dam gene is present and indicates that it is expressed and active in yeast cells. These experiments have been repeated with a second independent transformant and demonstrate the same kinetics and endpoints as those shown in Fig. 25, 26, and 27 (data not shown).

To further substantiate this conclusion, DNA from the transformant and the parent was digested with DpnI (Fig. 27A). The DpnI restriction nuclease only cleaves DNA when the GATC sequence is methylated at adenine (85,129,130). The results illustrate that the dam gene is expressed and methylates GATC sequences in yeast cells. The data in Fig. 27A also indicate that not all GATC sequences are methylated; there exist high molecular-weight DNA bands, as well as a considerable amount of DNA which bands at a position expected for completely undigested DNA (>25 Kb). The undigested DNA may exist because some cells have lost pMFH1, even though the cells were grown under selective conditions for the plasmid (236). Cells without plasmid will contain no dam methylase and their DNA will appear like the parental yeast strain. The large (5 to 25 kb) bands are not expected from a restriction enzyme which recognizes a 4-base pair (bp) sequence; this observation is also consistent with the hypothesis that not all GATC sequences are methylated. That unique bands appear suggests that specific GATC sequences might be resistant to methylation in

Figure 27 Evidence that *dam*-transformed yeast cells are susceptible to *DpnI* cleavage. Reaction conditions and size standards are as in Fig. 25. Sampling times were extended to 4 (lanes 5 and 11) and 8 (lanes 6 and 12) h. (A) Ethidium bromide-stained gel. (B) Southern blot probed by TRP1 DNA. Lanes 1 to 6 contain *DpnI*-digested untransformed parental DNA. Lanes 7 to 12 contain *DpnI*-digested, pMFH1-transformed DNA.

Discussion]

tion of a specifi

in the area of

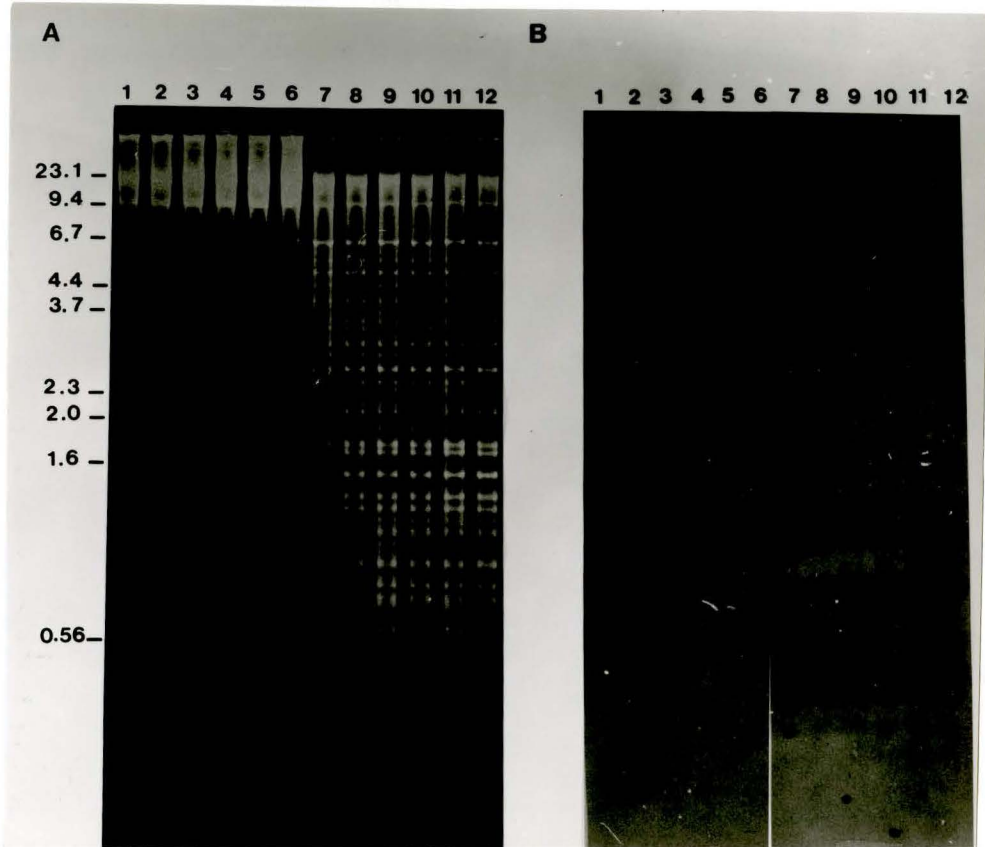

yeast cells (see Discussion).

Examination of a specific DNA sequence  
in the presence of *dam*

The experiments above examine the response of the total yeast genome to methylation by the *dam* methylase at GATC sites. To extend these observations and examine methylation patterns in a specific segment of DNA, we have used Southern hybridization analysis (231) (Fig. 25B, 26B, and 27B). The probe was a 1.4 Kb *EcoRI* fragment containing the *TRP1* gene. (A partial restriction map of the *TRP1* gene is shown in Fig. 28; see reference 241 for the sequence). The results show that transformants containing the *dam* gene have GATC sites in and around the *TRP1* region which are methylated. If complete digestion occurred at all GATC sites, the expected products would consist of 885- and 515-bp fragments and a small fragment of >84 bp (Fig. 28). The latter fragment is not visible with the electrophoresis conditions used. The *MboI* digest (Fig. 25B) demonstrates that DNA from a *dam*-containing strain is refractory to cleavage, whereas the same DNA is digested by *Sau3AI* (Fig. 26B) with similar kinetics and endpoint as the parental DNA. *DpnI* digests show that the *dam* gene methylates specific sequences in and around the *TRP1* region (Fig. 27B). Together, the data from the specific DNA fragment indicate that GATC sequences are methylated.

Some of the *TRP1* DNA appears to have been incompletely

Figure 28 Restriction map of TRP1 1.4 Kb EcoRI fragment.  
Schematic diagram representing the 1.45 Kb TRP1 region from YRp7 (241) used as a probe for Fig 25B, 26B, and 27B. E is EcoRI and M is MboI. The fragment contains two internal GATC sites at positions 852 and 1357 as defined in reference 241. The dark line represents the EcoRI fragment cloned into YRp7; the fine line represents yeast chromosomal sequences.



TRP 1-ARS 1  
(1453)

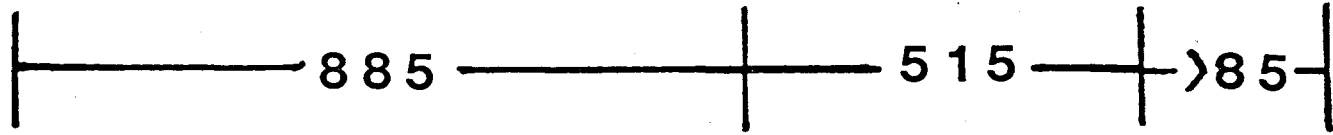

methyated (Fig. 25B and 27B); as in the total genomic digests, it is possible to account for this by the cells in the population which have lost pMFH1. Alternatively, hemi-methylation (methylation of A residues on one strand only) does not create DpnI-sensitive sites (128); this may also be a cause of the incomplete DpnI digestion. We have digested DNA from dam transformants under the same conditions as given in Fig 27 for a long as 18 h with no change in the restriction pattern or Southern hybridization profile. Therefore, the failure to obtain limit digests does not appear to be due to incomplete cleavage of sites which are, in fact, sensitive.

We have attempted to determine the fraction of TRP1 DNA completely digested by DpnI by calculating the amount of DNA in the 885- and 515-bp fragments (densitometer tracings not shown). From these, we determine that the fraction of the total TRP1 DNA in the partially digested or undigested positions for limit digests in Fig. 27B (i.e., bands larger than 885 bp) is approximately 55%. The average fraction of cells which do not contain the plasmid after selective growth is 31% (averaged from 14 cultures; data no shown). Thus, plasmid loss can account for much of the undigested DNA; hemimethylation of GATC may also contribute to the lack of complete digestion by DpnI (Fig. 27).

Effect of dam methylation on spontaneous  
mitotic recombination

Given the major effects that adenine methylation has on recombination in E. coli and its phages (7,150,189), we have asked what effect the heterologous expression of the dam gene would have on mitotic recombination in S. cerevisiae. The data in Table 27 indicate that transformants containing the dam gene have a small, but significant, increase in the frequency of mitotic recombination compared with the control strain ( $\chi^2 = 282$  (d.f. = 7);  $p < 0.001$ ). If we make a correction for the loss of the plasmid, and assume that only cells with the plasmid contribute to the observed increase, the frequency of mitotic gene conversion and crossing-over is elevated at seven of eight loci by adenine methylation in vivo ( $\chi^2 = 2,104$  (d.f. = 7);  $p < 0.001$ ).

Effect of dam methylation on meiotic recombination

Diploids containing the dam plasmid pMFH1 were sporulated and dissected, and a recombination map was calculated by the empirically derived formula of Ma and Mortimer (138) and by Perkins' formula (176). During sporulation, plasmids containing the 2 $\mu$ m origin of replication are lost from the cell (236). This generates tetrads that segregate in a non-4:0 fashion for the URA3 marker on pMFH1. Therefore, we have calculated two maps, one from all tetrads originating from the transformed MH16 and one from only those tetrads that segregated 4:0, 3:1, or 2:2 for the plasmids (Table

Table 27 Effect of *in vivo* adenine methylation on mitotic recombination

Strain	No. of Cultures	Recombination Frequency ( $10^6$ ) <sup>a</sup>							
		Intragenic						Intergenic	
		<u>lys2-1</u> lys2-2	<u>tyr1-1</u> tyr1-2	<u>his7-1</u> his7-1	<u>met13-c</u> met13-d	<u>trp5-c</u> trp5-2	<u>leul-c</u> leul-12	<u>can1<sup>R</sup></u> CAN1 <sup>S</sup>	<u>cyh2<sup>R</sup></u> CYH2 <sup>S</sup>
MH16	4	1.2	2.2	4.1	9.1	13.1	40.4	314	246
MH16 [pMFH1]	8	4.1	3.5	2.6	17.5	21.4	72.1	395	475
Relative Increase		3.4	1.6	0.6	1.9	1.5	1.8	1.3	1.9
Corrected MH16 [pMFH1]	8	5.0	4.0	3.4	19.3	25.3	86.3	408	942
Corrected Relative Increase		4.2	1.8	0.8	2.1	1.8	2.1	1.3	3.8

240

<sup>a</sup>Values given are geometric mean frequencies. The relative increase indicates the ratio of geometric means at a given locus, for strains containing pMFH1, over the untransformed control. The corrected values are geometric means calculated after correcting for plasmid loss. The corrected values are determined from the following formula: total number of recombinants = (number of cells without plasmid X MH16 frequency) + (number of cells with plasmid X corrected frequency).

28). There appear to be no major differences among the three maps in Table 28, and we conclude that 6-methyladenine has little effect on meiotic recombination.

#### Effect of *dam* methylation on mutation

In *E. coli*, overproduction of the *dam* methylase leads to increased mutation rates (7,98). Both forward and reverse mutation frequencies at several loci in yeast haploids containing the *dam* gene have been measured (Table 29). The haploids were obtained from the dissection of MH16 as discussed above. Two independent haploids which contained pMFH1 were examined. The result at one locus (*met13*) indicates that reversion is stimulated by adenine methylation at GATC. Two loci (*lys2* and *CAN1*) demonstrate a small increase in forward mutation frequency, whereas two other loci (*his7* and *leu1*) exhibit a decrease in reversion frequency. If we correct the data for the fraction of cells which contain plasmid (as done for the recombination frequency), these differences become more pronounced.

Table 28 Effect of *in vivo* adenine methylation on meiotic recombination

Map Interval	DAM-containing tetrads <sup>a</sup>					Total tetrads <sup>a</sup>					Standard Map Distance	
	P	N	T	X <sub>p</sub>	X <sub>e</sub>	P	N	T	X <sub>p</sub>	X <sub>e</sub>	X <sub>p</sub>	X <sub>e</sub>
<u>lys2-tyr1</u>	9	0	10	26.3	26.5	19	2	20	39.0	40.8	37.3	38.7
<u>tyr1-his7</u>	7	0	12	31.6	32.2	15	0	26	31.7	32.4	44.2	47.2
<u>ade5-met13</u>	3	2	13	69.4	97.1	10	4	25	62.8	77.4	68.7	94.4
<u>met13-CYH2</u>	9	1	7	38.2	39.8	22	1	14	27.0	27.3	15.0	14.8
<u>CYH2-trp5</u>	2	0	16	44.4	47.4	7	2	30	53.8	60.6	40.4	42.4
<u>trp5-leu1</u>	7	0	3	15.0	14.8	15	0	8	17.4	17.2	17.6	17.4

<sup>a</sup>p, N, and T refer to parental, non-parental, and tetra-type tetrads, respectively. X<sub>p</sub> is the map distance calculated by Perkins' (176) formula. X<sub>e</sub> is the map distance calculated via Ma and Mortimer (138). The DAM-containing tetrads are those that segregated 4+:0-, 3+:1-, and 2+:2- for pMFH1, whereas the total tetrads include the 1+:3- and 0+:4- tetrads.

Table 29 Effect of in vivo adenine methylation on mutation

Strain	No of. Cultures	Mutation Frequency ( $10^8$ ) <sup>a</sup>				
		Reversion				Forward ( <u>can1</u> <sup>R</sup> )
		<u>MET13</u>	<u>LYS2</u>	<u>LEU1</u>	<u>HIS7</u>	
±	3	0.89	83	2.9	2.4	220
± [pMFH1]	6	8.0	120	2.3	1.6	330
Relative increase		9.0	1.4	0.8	0.7	1.5
Corrected ± [pMFH1]	6	21.8	124	2.3	1.4	340
Corrected relative increase		24.5	1.5	0.8	0.6	1.5

<sup>a</sup>Values are geometric mean frequencies. Reversion frequencies represent auxotrophic revertants of the loci in Table 26; forward mutation is a measurement of CAN1<sup>S</sup> --> can1<sup>R</sup>. For the method used to correct for plasmid loss, refer to footnote <sup>a</sup>, Table 27.

## DISCUSSION

We have confirmed the report that the *E. coli* dam gene can be expressed in yeast cells and that the adenine methylase produced is capable of methylating GATC sequences (15). A GGCC-specific cytosine methylase gene has previously been transformed into yeasts. It was expressed and methylated yeast DNA (56). For the dam methylase, not all susceptible sequences appear to be fully methylated, because either insufficient enzyme is present, certain GATC sequences are inaccessible to the methylase, or N-6-methyladenine is efficiently removed by yeast repair systems. We favor the second explanation because of the discrete band patterns in the higher-molecular-weight sizes (2.3 to 21 Kb) observed in the DpnI digest (Fig 27). If the methylase recognized GATC sites randomly, we would not have expected to see discrete bands in fragments so large. In yeast DNA, which is 40% guanine plus cytosine (55), GATC sequences should appear randomly every 278 bp. A 10 Kb fragment could potentially contain 36 DpnI sites, and random methylation of these would generate a variety of fragments rather than the discrete bands observed. The complete digest of untransformed yeast DNA by MboI (Fig. 25A) revealed no fragments larger than approximately 2.3 Kb. This indicates that any yeast DNA fragment larger than 2.3 Kb in the DpnI digest contains at least one GATC sequence that was not cleaved. That the dam methylase might preferentially methylate specific GATC



sequences in yeast chromatin suggests that the higher-order structure of chromosomes may determine what DNA sequences are accessible. The dam gene may therefore serve as a useful in vivo probe for comparing chromatin structure before and during such cellular events as transcription and replication.

Although Sau3AI digests of the parental and transformant DNA were identical, the limit digests contained many specific bands at sizes larger than 2.3 Kb. We have used several different preparations of Sau3AI from different commercial sources. All enzymes gave similar results. The complete MboI digest of untransformed DNA confirms that the large Sau3AI fragments must contain GATC sites (see argument above). One possible reason that certain GATC sites are not cleaved by Sau3AI is that Sau3AI is known to be sensitive to methylation of the cytosine in the GATC sequence (159,235). Most eukaryotic cytosine methylation occurs at CG sequences; therefore GATCG sequences, where the C were methylated, would be resistant to cleavage by Sau3AI. The estimates for cytosine methylation in yeasts range from approximately 1% (93) to 0.03% (188). If the latter value were correct, there are potentially 2,000 5-methylcytosine residues in a diploid genome. Our data are consistent with the existence of small amounts of 5-methylcytosine in yeasts. It is important to note that the digestion pattern of DNA fragments smaller than 2.3 Kb are undistinguishable for both

Sau3AI and MboI (Fig. 25 and 26). We conclude that whatever is preventing Sau3AI from completely digesting yeast DNA is not present in all GATC sequences in the population because the limit digest is often reached.

The central role of 6-methyladenine in recombination and mismatch repair in E. coli led us to determine the response of a eukaryotic cell to this modified base. Exogenous alkylating agents, such as Methyl Methane Sulfonate, stimulate recombination and mutation in yeasts, but they do not primarily methylate the N6 position of adenine. Methylation of adenine in GATC sequences had relatively little effect on meiotic recombination in yeast cells. Meiotic cells containing the dam clone demonstrate no significant effect on map distances; we conclude that adenine methylation does not affect meiotic crossing-over. We have not yet proven that meiotic gene conversion is unaffected, but we consider it probable that there will be little effect. Fogel et al. (64) have shown that meiotic gene conversion and crossing-over are correlated; they may reflect alternative aspects of a single recombination process. Since meiotic crossing-over shows little change in dam transformants, we feel it likely that meiotic gene conversion will respond similarly.

In the presence of the dam gene mitotic recombination does show a 2.2-fold average increase after correction for plasmid loss. This observation extends to gene conversion at five of six loci examined and crossing-over at two loci.

We suspect that these effects are nonspecific rather than due to GATC sequences being directly involved in yeast recombination per se. In other words the stimulation comes from the addition of a methyl group to adenine, rather than the modification of a specific sequence (see below). The increase in mitotic recombination might result from double-stranded breaks generated by overlapping excision tracts on opposite DNA strands (239). [In contrast E. coli strains with decreased amounts of methylation (i.e. dam) are hyper-recombinogenic (190)]. Alternatively, single-stranded gaps created by repair of 6-methyladenine might themselves stimulate mitotic recombination. To test whether heteroduplex formation and correction is stimulated by in vivo 6-methyladenine, it would be useful to look at recombination frequencies in strains deficient in heteroduplex correction [such as cor mutations (63)] or excision-repair (i.e., rad1 and rad3) to determine if frequencies were still elevated.

Mutation frequencies were increased 1.5-, 1.5-, and 25- fold at three loci in the transformants containing the dam clone; two other loci exhibited very slight decreases. These effects are substantially less than the 10- to 300-fold increase shown in E. coli strains which overproduce dam (98). Two explanations of the slight mutagenic effect of 6-methyladenine in yeast cells are that it mispairs frequently or is recognized and acted upon by error-prone repair. Methylation at the N-1, N-3, and N-7 positions of adenine is

potentially mutagenic (in both prokaryotic and eukaryotic cells) because either base pairing is directly affected or specific glycosylases remove the alkylated base followed by error-prone repair (228). Whereas methylation at the 6 position of adenine is presumably not mutagenic in E. coli, there is a possibility that it might be in eukaryotes. The electrophilic nature of the methyl group affects the keto-enol equilibrium of adenine and could thereby affect the frequency of mispairing during replication. If true, mutations found in yeast strains containing dam should preferentially occur at GATC sequences (i.e., in a targeted fashion). If, on the other hand, 6-methyladenine stimulates error-prone repair, mutations might occur anywhere, depending on the number of nucleotides degraded and resynthesized.

The effects of methylation at the N6 position of adenine in yeast GATC sequences are substantially less severe than the response to other adenine-alkylating mutagens such as methyl methane sulfonate. This may be due to the relative frequency of GATC sequences compared to the probability of methylating random adenines and other bases. Alternatively, it may reflect that 6-methyladenine is less recombinogenic and mutagenic than 3-methyladenine, the primary adduct formed by Methyl Methane Sulfonate (228). We tend to favor the former explanation because it more easily explains the discrepancy in the observed effects on muta-

tion. The met13 locus, for example, displayed a 25-fold increase in reversion, whereas reversion at the his7 locus was decreased by 1.7-fold. This would be understandable if the number of susceptible GATC suequences varied from locus to locus.

We are currently testing the effects of mutations in the various yeast repair esistasis groups (96) on the responses to in vivo dam adenine methylation. It has been proposed that nucleotide exision is the major DNA metabolic pathway by which alkylation adducts in DNA are eliminated (90). To examine this, an integrating plasmid has been constructed to avoid the complication of plasmid loss. Strains containing an expressed, integrated dam gene will allow us to easily control for copy number and should permit an examination of the effects of heterologous dam methylation in cells deficient in the ability to repair DNA damages.

## CHAPTER VII

### EXCISION-REPAIR FUNCTIONS IN YEAST RECOGNIZE AND REMOVE N-6-METHYLADENINE CREATED IN VIVO<sup>6</sup>

DNA methylation has profound and varied effects on cellular metabolism. Higher eukaryotes exhibit methylation of specific cytosines during the regulation of gene expression (2,40). The genomes of lower eukaryotes, such as Drosophila (1), Saccharomyces cerevisiae (93,188) and various other fungi (56,93), have a low 5-methylcytosine content, suggesting that DNA methylation may not be involved in gene control in these organisms. Prokaryotes employ methylation in their restriction-modification systems (159) and in mismatch repair recognition (189). The Escherichia coli dam gene product methylates at the N6 position of adenine residues in 5'-GATC-3' sequences as part of the methyl-directed mismatch repair system (189). Insults by exogenous methylating agents lead to increased mutation and recombination rates and cell death in both prokaryotes and eukaryotes (96). Considering the variety of cellular responses to DNA methylation, we have been interested in determining if and how S. cerevisiae reacts to in vivo DNA methylation by the E. coli dam gene product.

<sup>6</sup> M. F. Hoekstra and R. E. Malone, 1986. Nature (submitted)

Previously we have shown that the yeast cell expresses a cloned dam gene and methylates its chromosomal DNA (103). Methylation causes a general 2 fold increase in mitotic recombination and a similar increase in mutation frequencies at some loci. In this report we demonstrate that S. cerevisiae actively removes N-6-methyladenine by using the excision-repair epistasis group. We infer that the yeast excision-repair pathway can respond not only to UV-induced cyclobutyl rings (9) or strand cross-linking (5) but also to a potentially non-helix distorting adduct such as 6-methyladenine.

Yeast cells have three repair groups for coping with changes in normal DNA structure (reviewed in 96). These groups are named after a prominent locus and include: i) the loci of the RAD3 group which are UV sensitive mutations and participate in UV excision repair, 2) the RAD52 group, defined by X-ray sensitive mutations, many loci of which are involved in mitotic and/or meiotic recombination, and 3) the loci of the RAD6 group which influence UV and X-ray sensitivity and control error-prone repair. To determine how the yeast cell responds to the dam-produced in vivo adenine methylation, we integrated the dam gene into the yeast genome and examined cells containing the dam gene along with mutations in error-prone (rad6-1), recombination (rad52-1), or excision (rad1-2, and rad3-2) repair. Yeast spheroplasts were transformed with YIpDAM (Fig. 29) and stable integrants

Figure 29 Construction of YIpDAM. The plasmids pBR322 and pRK99 were each digested by HindIII and PvuII using conditions recommended by the supplier (BRL) and electrophoresed through 0.7% low melting temperature agarose (BRL). The 2.3 Kb HindIII-PvuII band from pBr322 and the 1.1 Kb dam-containing fragment from pRK99 were extracted (101) by heating in the presence of phenol and ethanol precipitation. The fragments were ligated with T4 DNA ligase and CaCl<sub>2</sub>-mediated HB101 transformants were selected by ampicillan-resistance. The 1.1 Kb URA HindIII fragment from YEp24 was introduced into the unique HindIII site of pBR-DAM and ampicillan-resistant, uracil-independent transformants of MC1066 (103) were selected on minimal medium containing ampicillan.



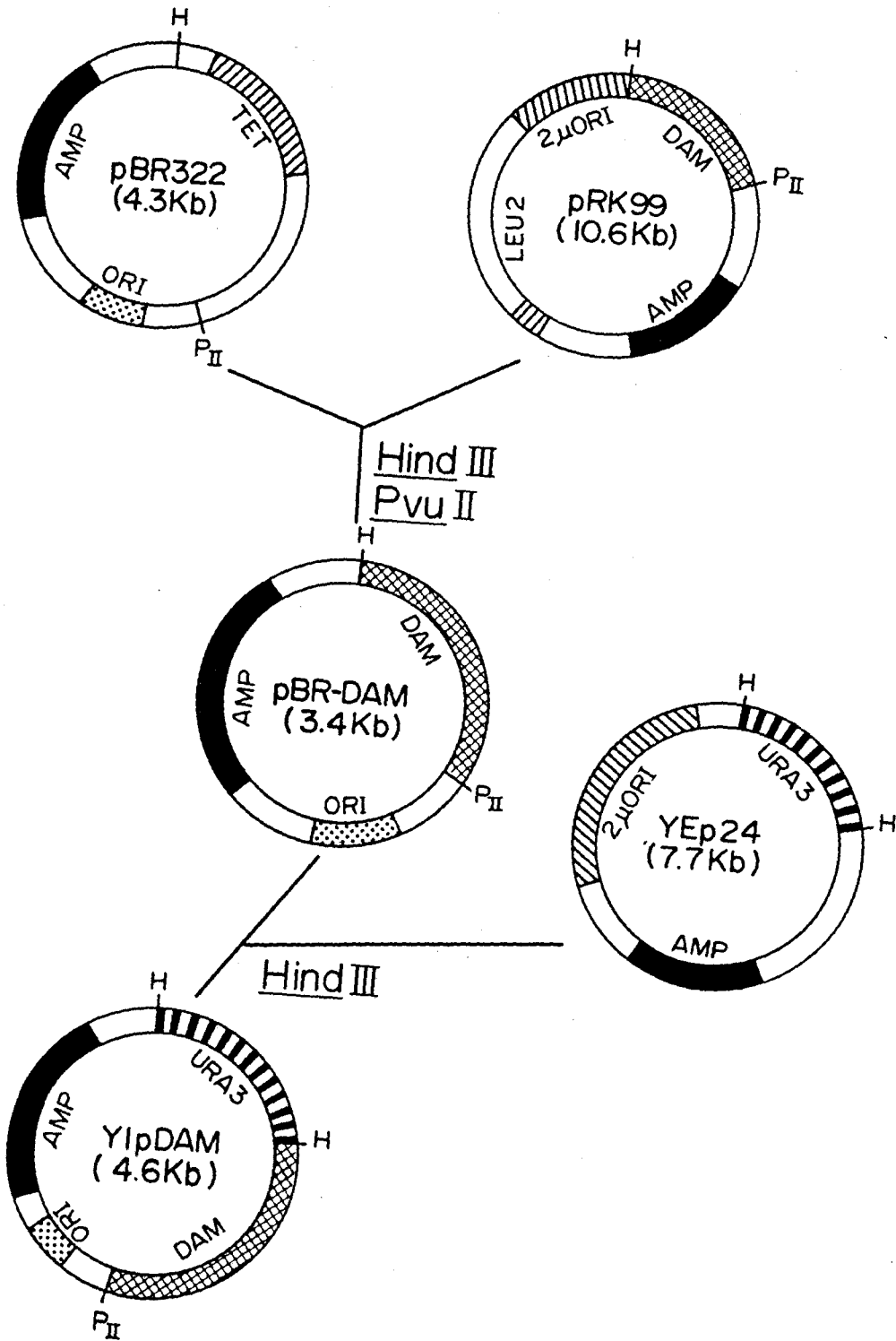

selected (103). Demonstration that the integrated dam gene is stable and expressed is shown by tetrad analysis (Fig. 30). Spores from a hemizygous dam strain were dissected and DNA from the resulting spore clones digested by DpnI, [which cleaves at GATC only when the A is methylated (129)] . In all cases examined (5 tetrads) the dam gene segregated with Ura<sup>+</sup>. Specific methylation in a defined chromosomal region was examined by Southern analysis using as a probe a 1.4 Kb EcoRI fragment containing the TRP1 gene (103). Similar to previous results for a high copy number episomal plasmid, not all potential GATC sites were digestible by DpnI (103). If the TRP1 region were completely methylated at GATC, fragments 885 base pairs, 515 base pairs, and >84 base are expected from sequence data. Larger fragments (>885 bp) must contain GATC unmethylated GATC sites. This may be due to inefficient functioning or low levels of the E. coli gene product in yeast resulting in incomplete methylation, higher order chromosomal structures protecting GATC sequences from the dam enzyme, or the active removal of methyl groups by yeast repair systems.

To test the possibility that repair processes might play a role in the phenotype of dam-containing yeast cells, diploids heterozygous for both dam and various rad genes were constructed. Dissection of tetrads and subsequent analysis of segregants indicated that all double combinations are viable (Table 30). Thus, N-6-methyl adducts on

Figure 30 Analysis of dam-produced methylation in repair-deficient mutants. DpnI-digested DNA from various strains is shown. The genotypes are shown above each lane.

METHODS: DNA was isolated from 5 ml overnight cultures of cells. The cells were sedimented in a table top centrifuge, washed, and resuspended in 0.5 ml of 1.0M sorbitol, 0.1M EDTA, 14 mM 2-mercaptoethanol (pH7.5) containing 2mg/ml zymolyase (Kirin Breweries). After 45 minutes at 37° C, the spheroplasts were sedimented in a microfuge, resuspended in 0.5 ml of 50 mM EDTA, 0.2% NaDodecylSulfate (pH5.8), heated at 70° C for 15 minutes after adding one  $\mu$ l of diethylpyrocarbonate. Fifty  $\mu$ l of 5 M potassium acetate was added and the mixture placed on ice for 1 hour. Cellular debris was removed by centrifugation and total nucleic acids precipitated by the addition of 1 ml of 95% ethanol and freezing at -70° C. The nucleic acids were resuspended in 0.2 ml TE containing 10  $\mu$ g/ml RNase A and held for 15 min at 37° C. The mixture was phenol extracted and the DNA precipitated by ethanol. Final yield of DNA ranged from 10 - 30  $\mu$ g. Each lane contains approximately 5  $\mu$ g of DNA digested by 4 units of DpnI for 6 hours before electrophoresis through 1% agarose. Gels were run overnight at 30 mA constant current. Southern analysis was as described (103) and the probe was a nick translated 1.1 Kb EcoRI fragment containing the TRP gene from YRp7 (103).

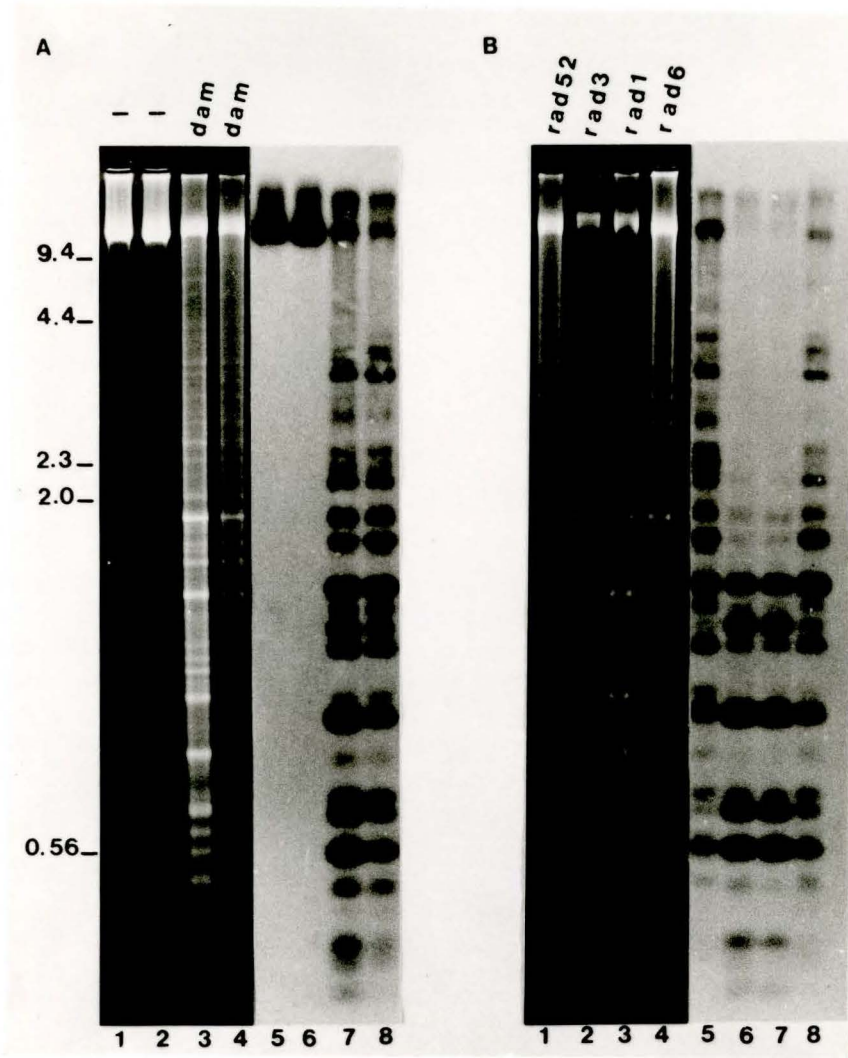

Table 30 Segregation analysis for dam/--- RAD/rad diploids

Diploid Genotype	Viable Spore Genotype			
	<u>RAD</u> X <u>dam</u> <sup>±</sup>	<u>RAD</u> X ---	<u>rad</u> X <u>dam</u> <sup>±</sup>	<u>rad</u> X ---
<u>dam</u> <u>+</u> --- <u>rad</u> 52-1	13	25	22	13
<u>dam</u> <u>+</u> --- <u>rad</u> 6-1	22	12	10	20
<u>dam</u> <u>+</u> --- <u>rad</u> 3-2	10	19	17	12
<u>dam</u> <u>+</u> --- <u>rad</u> 1-2	14	22	20	14

Wild type strains containing an integrated dam gene were mated with the various rad mutations listed above. The hemizygous dam, heterozygous rad diploids were sporulated and tetrads dissected using standard procedures (101). Segregants were analyzed for the presence of dam and rad mutations. radX refers to the rad mutations listed under the diploid genotype for a given row.

adenine are not lethal in haploid strains containing mutations in any of the three major yeast repair epistasis groups.

The dam gene is expressed in all of these strains (Fig. 30). DNA from all dam rad strain combinations is susceptible to DpnI digestion while DNA from strains lacking the dam gene is not digested by DpnI. Southern analysis of the TRP1 region in rad6-1 and rad52-1 demonstrates a hybridization pattern similar to the wild type dam-containing haploid parent. However, rad3 and rad1 strains containing dam present greater DpnI susceptibility (Fig. 30). This indicates that there may be sufficient dam gene product present in yeast to methylate all GATC sequences, and that chromosome structure may not play a role in preventing methylation. Analysis of complete tetrads from hemizygous dam heterozygous rad1 (or rad3) diploids by DpnI digestion confirmed the observation that excision-repair mutants did not remove N-6-methyl groups. Tetra type tetrads with all four possible segregants were analyzed to reduce the effect of strain variations; DNA from dam rad1 and dam rad3 was digested to a greater extent by DpnI than wild type dam-containing sibling segregants (Fig 31). Strains deficient in excision-repair allow more 6-methyladenine to accumulate, indicating that wild type cells are able to remove 6-methyladenine from chromosomal DNA using an excision-repair mechanism previously known to act on damages such as UV-

Figure 31 Segregation analysis of dam-methylation in Tetra Type tetrads for dam and rad1 or rad3 strains. D p n I digested DNA was from the following strains: MH73-3A (1), MH73-3B (2), MH73-3C (3), MH73-3D (4), MH75-8A (5), MH75-8B (6), MH75-8C (7), MH75-8D (8). Relevant genotypes are given above each lane. DNA isolation, digestion, and Southern analysis was as described in Fig 30.

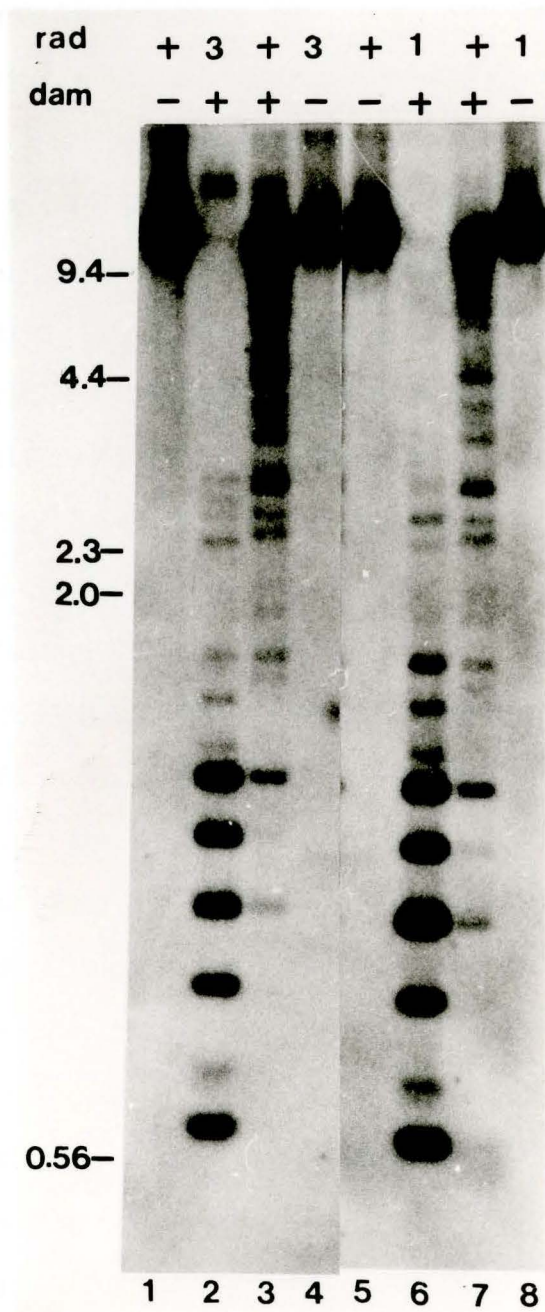



induced cyclobutyl dimers and psoralen cross linking (5). Thus, excision-repair appears to be a central repair system in yeast, possibly involved in the initial recognition and reaction to many (and quite subtle) DNA structural changes.

Transformation studies in yeast and transfection studies in mouse, monkey, and human cells have recently demonstrated that the input DNA accumulates base substitutions and rearrangements (21,29,133,221). Prior exposure of the cells to UV or EMS induces a further error-prone replication environment (221). High rates of recombination and gene expression have also been reported for the transfected DNA (66,84). A distinguishing feature of the introduced DNA in all these experiments is that the DNA has been "cleansed" by propagation in E. coli prior to transfection; not only is the DNA free of chromatin structure, but in most cases contains modification and dam-produced methylation. For E. coli, adenine methylation is a normal occurrence; in fact the absence of N-6-methyladenine leads to hyper-recombination and hyper-mutation (7). In yeast the opposite appears to be true. Introduction of the dam gene to S. cerevisiae stimulates mitotic recombination and (at some loci) mutation (103). The yeast cell recognizes and responds to the methyl adduct by using its excision-repair system. Current evidence suggests that rad1 and rad3 are blocked at a stage involved in the incision step of excision-repair (202,203). Considering the observed increases in both mitotic recombin-

ation and mutation caused by the cellular responses to this methylation, it is possible that the other repair systems may act on the intermediate created by excision-repair.

An interesting paradox is generated by this study with respect to the transfection of higher eukaryotic cells. DNA containing N-6-methyladenine stimulates cellular responses which can lead to mutants and recombinants in a lower eukaryotes like yeast. Using a dam<sup>-</sup> E. coli strain as a host for plasmid preparation may seem to be a simple solution to this problem. However, these E. coli strains are hyper-mutable. This creates the problem of pre-existing mutations potentially being present in the plasmid population prior to introduction to eukaryotic cells.

## CHAPTER VIII

### GENERAL DISCUSSION

Mitotic DNA metabolism as it relates to the process of genetic recombination has been the topic of this dissertation. The majority of study has focused on two mutations that define a gene called REMI. The rem1 mutations confer a mitosis-specific, semi-dominant, hyper-rec/hyper-mutable phenotype; they have no apparent meiotic phenotype. The first allele, rem1-1, was isolated on the basis of a mutator phenotype and subsequently shown to be a recombinator. In this dissertation, a second allele (rem1-2) has been described. The mutation was isolated as a dominant recombinator (Chapter 2 and reference 143) and, depending upon the locus examined, confers approximately a 10 - 20 fold stimulation in spontaneous recombination levels when homozygous. Mitotic mutation levels are similarly elevated in rem1-2. Thus, on the basis of this brief description, one can infer that the REMI gene product is jointly involved in recombination and mutation.

Malone, Golin and Esposito (142) examined the distribution of recombination in rem1-1 strains. Comparing the relative amount of recombination along a chromosome arm, a mitotic centromere affect is normally observed. There is a compression of the relative amount of recombination in mito-

tic cells at centromere proximal regions compared to meiotic cells. For two reasons, the affect is believed to be a property of the centromere. First, centromeric regions appear to have approximately 50% more centiMorgans/kilobase compared to regions distant from the centromere (32). Second, when a centromere is moved to a chromosomal region normally without a CEN, a decrease in local meiotic recombination frequencies has been reported (171). Homozygous rem1-1 strains have a distribution of recombination along chromosome VII that is intermediate to wild-type mitotic and meiotic cells (Figure 32 and reference 142). The centromeric proximal region is expanded in rem1 mitotic cells. This result led to the proposal that rem1-1 might "turn-on" meiotic recombination functions during mitosis (142,143). This would also be consistent with the increase in recombination frequencies caused by rem1, since meiotic recombination occurs at  $10^3 - 10^4$  higher frequencies than mitotic recombination (50). The proposal was tested by determining if rem1 strains deficient in meiotic recombination functions maintain the hyper-rec phenotype. Specifically, double mutants of rem1 with rad6-1, rad50-1, rad52-1 or spoll-1 were constructed. Double mutants of rem1-2 rad6-1 and rem1-2 spoll-1 showed rem1-2 hyper-rec levels (141). If the normal, complete meiotic recombination system is responsible for the rem1 hyper-rec phenotype, one might predict that inactivating meiotic recombination functions would reduce

Figure 32 Relative recombination levels along chromosome VII. Values are taken from Malone, Golin, and Esposito (142). The recombination for the complete arm is totaled and percent recombination for the three intergenic regions is presented. The dark circle represents the centromere.

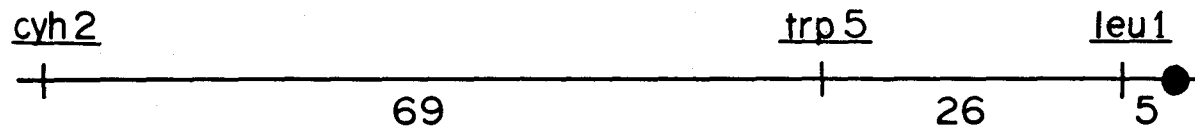
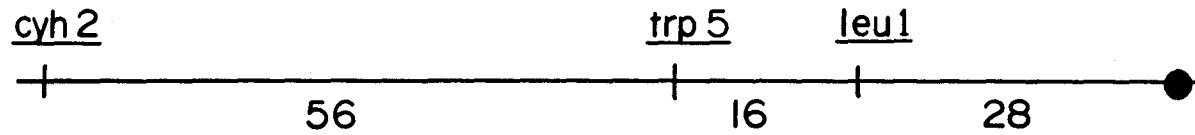
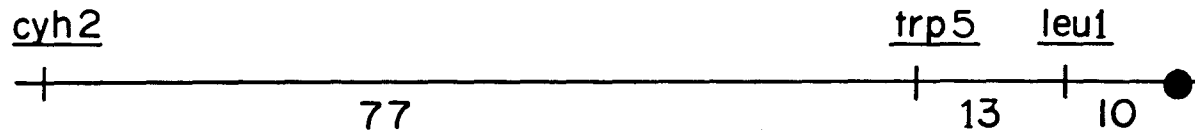
Meiotic MapMitotic MapsREM1/REM1rem1-1/rem1-1

rem1 hyper-recombination levels. Since this was not observed, rem1 hyper-recombination is most likely not due to an induction of meiotic recombination function(s) during mitosis.

The rem1-2 rad52-1 double mutant could not be constructed (143). Double mutant segregants from rem1/REMI RAD52/rad52-1 diploids were unable to form colonies. To determine if this phenotype was due to the recombination or repair phenotype of rad52-1, construction of rem1-2 rad50-1 double mutants was attempted. [Both rad50-1 and rad52-1 confer X-ray sensitivity and a deficiency in doublestrand break repair. However, these mutations differ in that rad50-1 is proficient for mitotic recombination while rad52-1 is deficient (139,140).] If the double mutant inviability of rem1 rad52-1 is due to the mitotic recombination deficiency conferred by rad52-1, and not the repair deficiency, rem1-2 rad50-1 double mutants should be viable. This is not the case. Similar to the rad52-1-containing strains, rem1-2 rad50-1 double mutants are inviable (143). A simple explanation of these data is that rem1 strains contain a lethal recombinogenic DNA lesion which requires the recombination-repair group.

While examining interactions between rem1 and meiotic Rec<sup>-</sup> mutations, it was found that rem1 rad6-1 double mutants are viable. Strains containing rad6-1 are defective in the putative error-prone mode of DNA repair for induced muta-

tions (71,96,184). The rad6-1 mutation confers a deficiency in meiotic recombination (74,141) and, as mentioned, rem1-2 rad6-1 double mutants retain rem1 hyper-rec levels, reinforcing the notion that rem1 hyper-recombination does not rely on the complete meiotic recombination system. Furthermore, the availability of double mutants with rad6-1 allowed determination of rem1 mutation levels in the absence of a mutagenic repair system. In terms of a simple channelling hypothesis for mutation, as proposed by Von Borstel and co-workers (71,92, 244), when an induced DNA lesion occurs it is acted upon by repair pathways and cellular functions process the lesion into a mutation. If induced mutations occur strictly in this manner, then removing the ability to perform error-prone repair should decrease the ability to induce a mutation. Spontaneous mutation might be different. For example, a genetic lesion such as a replication error, if unrecognized by the cell, can become a mutation following a subsequent round of DNA synthesis. Repair is not required. Spontaneous mutation rates in rem1-2 rad6-1 strains were found to be elevated. If rem1-caused DNA lesions were similar to lesions created by many genotoxic treatments, then mutation rates should be reduced in the absence of the error-prone repair function RAD6 (184). Alternatively, if rem1 DNA lesions are similar to spontaneous mutation, then mutability could be independent of RAD6. By this analysis, the DNA lesion that occurs in



rem1-2 strains appears to mimic spontaneous lesions by not requiring RAD6. The mutations rad1 and rad4 do not confer elevated spontaneous mutation rates. The channelling model predicts that lesions normally processed by a repair system are shuttled to another repair pathway when the normal route is blocked. Since this is not the case for rad1 and rad4, it appears as if the channelling model is not applicable for spontaneous mutation or for rem1-induced mutation.

As an aside, the original version of the channelling model was based upon the measurement of mutation rates in rad6-1 and rad51-1 mutant strains (92). Similar to the results presented here, Hastings *et al.* (92) found approximately wild-type mutation rates in rad6 strains and slightly elevated rates in rad51 strains. Extending these studies, Brychcy and von Borstel (20) examined mutation rates in rad3-17 strains. They found that this rad3 allele is a "mutator" mutation (20,94), although close examination of the literature demonstrates that the increase is only small. This rad3 mutation appears to be unusual in that it is the only UV-sensitive rad3 mutation described as a mutator. Unfortunately, the rad3 allele described by Brychcy and von Borstel has not been independently confirmed by other researchers to be a mutator as this allele is not widely distributed. Contradicting these results, Zimmerman and Kern (266) have examined rad3-2 for its mutability and found there is, at most, a two-fold effect. Beyond this,

the assays for mutation used by the groups above have relied upon measurements at a single locus in a "D7" tester background. Since mutator phenotypes appear to be dependent upon test systems (94), the use of a single locus to measure mutation is not always wise. The conclusions presented in this dissertation are drawn from measurements of mutation at multiple loci by several methods and therefore are felt to be correct. Although the channelling model appears to be a good framework for induced mutation, the results in this dissertation show that, at least for rem1 spontaneous mutation, the channelling model is not appropriate. While the reasons for the discrepancies between results are not entirely clear, part of the problem may reside in strain backgrounds and/or test systems.

Returning to REM1, the simplest assumption for the action of the rem1 mutation is to propose that a single type of DNA lesion occurs in the mutant which may be processed into a number of different forms. Considering the varying lesions recognized and responded to by excision-repair functions in yeast, one might predict that the hyper-recombination occurring in rem1-2 could require excision-repair functions. To test this, double mutants of rem1-2 with excision-repair defective mutations were constructed. Both rem1 rad1-2 and rem1 rad4 double mutants are viable. These double mutants are specifically reduced for spontaneous mitotic gene conversion. rem1 hyper-gene conversion

requires at least the RAD1 and RAD4 excision-repair functions.

Since the excision-repair mutations reduce the hyper-rec phenotype of rem1, the excision-repair functions may be involved in the recognition and processing of the rem1 DNA lesion. We suppose that this "processing" can lead to a double-strand break which is subsequently repaired by the recombination-repair system. Such repair often results in a gene conversion event. The exact mechanism for generating a double-strand break is not entirely clear. However, as in E. coli strains with dam and dut mutations, overlapping repair tracts on both strands of the helix can lead to a double-strand break (190,239). Regardless, if excision-repair functions are involved in the "processing" of a rem1 DNA lesion, then mutating a required excision-repair function should prevent the "processing", and in turn prevent the occurrence of the double-strand break. If no double-strand breaks are formed, then rem1 strains with mutations in RAD1 or RAD4 should be viable in combination with defects in recombination-repair (eg. rad50 and rad52). This prediction was demonstrated experimentally. Triple mutants lacking recombination-repair, excision-repair and containing rem1 (eg. rem1-2 rad1-2 rad52-1) are viable. Removing the ability to perform the incision step of excision-repair, "rescues" the rem1 rad50-1 and rem1 rad52-1 double mutant inviability. One interpretation of these data

is that hyper-gene conversion occurring in rem1 strains proceeds through excision-repair and recombination-repair functions. A DNA lesion occurring in rem1 strains requires the recognition and response of excision-repair functions for hyper-gene conversion to occur. By blocking excision-repair with rad1-2 or rad4, the recombinogenic lesion that requires double-strand break repair functions for viability is inhibited. Thus, rem1 strains lacking excision-repair capabilities are able to survive without recombination-repair.

Although this scheme is consistent with the hyper-gene conversion caused by rem1, it leads to a surprising conclusion for crossing-over. Increased levels of drug-resistance are observed in rem1 strains containing mutations in excision-repair. These were shown to be primarily cross-over events. Drug-resistance frequencies are also elevated in the triple mutants. However, because rad52 strains show increased chromosome loss, at least part of the drug-resistant population in triple mutants may be due to chromosome loss events. If some of the drug-resistant colonies from rad52-1-containing triple mutants are cross-over events, an interpretation of these data is that if the rem1 DNA lesion is not processed by excision-repair, it can be acted upon by other functions which result in cross-overs. These recombination events may not involve double-strand breaks.

To summarize, excision-repair functions appear to be

involved in rem1 hyper-gene conversion but not crossing-over. Therefore, gene conversion and crossing-over occurring in rem1 strains can proceed by two mechanisms. The first mechanism responsible for most, but not necessarily all, gene conversion involves "processing" by excision-repair and recombination by double-strand break repair functions. The second mechanism, involving crossing-over, can occur in the absence of excision-repair and probably double-strand break repair products. Since the recombination-repair functions are involved in double-strand break repair (71,96), the majority of rem1 gene conversion seems likely to occur by a double-strand break mechanism such as that as proposed by Szostak et al. (239) or Resnick (193). Since rem1 hyper-crossing-over may occur in the absence of double-strand break (recombination) repair functions, crossing-over events might occur by a single-strand invasion model as described by Meselson and Radding (156).

These data indicate that rem1-created crossing-over may occur by a mode independent of RAD52. Attempts were made to confirm that the crossing-over was independent of other recombination-repair functions by using triple mutant strains containing rad50-1 instead of rad52-1. However, definitive conclusions are difficult as rad50-1 strains alone are hyper-rec (139). One pertinent observation from the rad50-1 study that supports the contention that rem1 crossing-over can occur by a mechanism independent of

double-strand break repair is taken from the data shown in Figure 33. Strains containing rad50-1 are slow growing, with a doubling time of approximately 130 minutes (compared to wild type strains with a doubling time of approximately 75 - 90 minutes) and rem1 rad50 double mutants are inviable. Introduction of rad1-2 into rad50-1 strains increases growth rates to rad1-2 levels. Perhaps the rad1 mutation inhibits spontaneous lesions from reaching a RAD50 reaction stage or, conversely, maybe a rad50 DNA lesion is prevented from becoming a lethal lesion. Introduction of rem1-2 into the double mutant, creating a viable triple mutant, reduces growth rates to levels even slower than rad50-1. By virtue of the fact that these triple mutant strains are viable (but slower growing), that rad50-1 strains are deficient in double-strand break repair (71), and that conversion and crossing-over occurs in these triple mutants, an explanation for the slow growth rate is that cells are being taxed to their survival limit because most recombination is being forced to occur by a mechanism which does not use the major recombination-repair functions. In other words, with a full complement of excision-repair and recombination-repair functions, rem1 hyper-recombination can proceed in a fashion similar to spontaneous recombination by using the RAD52 double-strand break repair set of gene products. However, when recombination-repair is inactivated, the rem1 lesion leads to lethality, perhaps because of unrepaired double-

Figure 33 Growth curves and doubling times in various rem1 and rad-containing strains. Cell counts were made from duplicate hemocytometer readings at various time points.

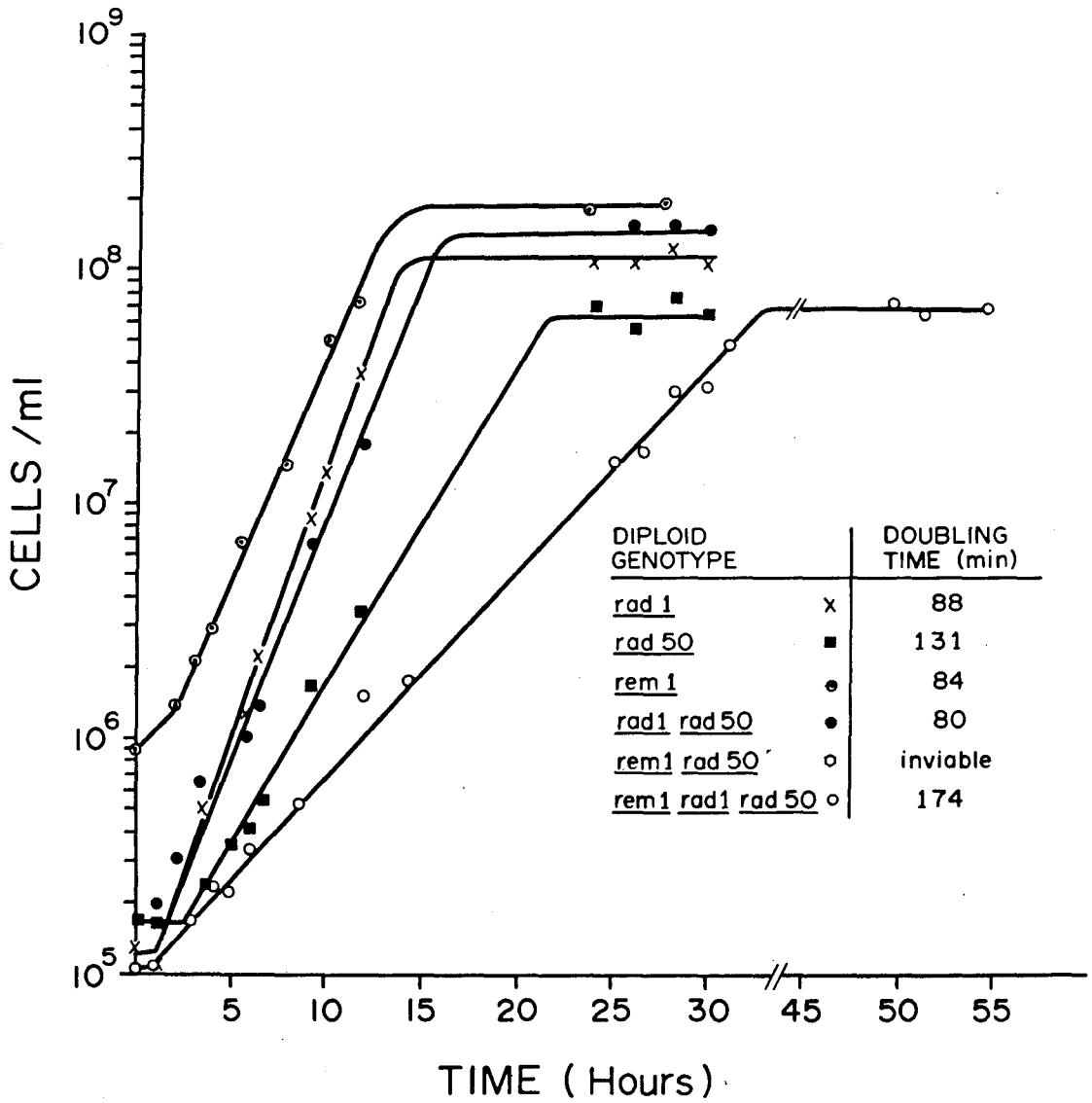



strand breaks. By reducing or inhibiting rem1 hyper-gene conversion with an excision-repair mutation, cells deficient in double-strand break repair can survive. These cells may recombinationally repair the rem1-caused DNA lesion in a fashion independent of the double-strand break repair group.

A relevant observation supporting the contention that rem1 crossing-over can occur by a non-double-strand break mode is taken from the plating efficiencies of triple mutants. Normally, cells are harvested for recombination measurements when a visual count is between  $1 - 4 \times 10^7$  cells/ml (143). For most strains the plate count is usually around 50 - 75% of this value because budded cells, visually counted as 2 cells, only grow into a single colony. In an experimental population, about 2/3 of the cells are budded. If the rem1 DNA lesion were processed into a double-strand break in the triple mutant, one might predict a drastic reduction in plating efficiency since unrepaired double-strand breaks are lethal in the absence of recombination-repair (140). This is not the case. Triple mutants have a similar ratio of plate-count to visual count compared to rem1 strains alone (data not shown).

The results from the study of rem1-created mitotic recombination argue that homologous recombination might be able to occur without RAD52. As part of the investigation of mitotic recombination functions and their effect on rem1, unusual effect of the rad52 mutation was noted. Examina-

tion of published gene conversion frequencies (140) showed that rad52-1 strains had a relatively uniform frequency of intragenic recombination. To directly test whether gene conversion can occur in the absence of RAD52, the frequency of prototrophs arising from heteroallelic configurations in rad52-1 was compared to reversion frequencies for the alleles comprising the locus. It was found that prototrophs occur approximately ten fold more frequently from heteroalleles than homoalleles in rad52-1 stocks. In other words, spontaneous mitotic intragenic recombination (gene conversion) can occur without RAD52. This is true even though reversion frequencies are slightly elevated in a rad52-1 background (186). As mentioned, the intragenic recombination occurring in rad52-1 strains, at a number of heteroalleles, was more uniform in frequency than wild-type (140). To examine this property more closely, a set of six alleles within a given genetic distance, the LYS2 gene, were used to define the recombination between different heteroalleles to a single genetic interval. Similar to the results of Malone and Esposito for inter-locus comparisons (140), recombination at LYS2 is reduced and relatively uniform in rad52-1. As argued in Chapter 5, low-level mitotic heteroallelic recombination occurs in rad52-1 mutant strains, possibly by another recombination pathway present in a Rad52<sup>-</sup> cell. This notion is not unique. Haber and Hearn (88) examined spontaneous mitotic recombination

between homologs with his4 heteroalleles and easily detectable outside markers. They found that recombination at his4 occurred in rad52-1-containing strains. Similar to our study at LYS2, the pattern of intragenic recombination at his4 was altered. However, close examination of the His<sup>+</sup> protrophs demonstrated that they arose by gene conversion. Haber and Hearn did not detect the reciprocal double his4 mutant.

Published data suggests, in some instances, that crossing-over can occur in rad52-1 strains at normal levels (122,172,184,263). (An observation also proposed from the rem1 data discussed above.) One interpretation of the uniform recombination frequencies is that all heteroduplexes, containing each heteroallele mismatch, are formed with equal probability. This suggests, by a single-strand invasion mechanism (156), that the RAD52 function plays a role in the formation and correction of mismatches. If the major pathway of mitotic recombination is blocked with the rad52-1 mutation, a cell is forced to use other routes. All data indicate that RAD52 is involved in double-strand break repair (71). If spontaneous mitotic recombination normally occurs by a double-strand break, a Rad52<sup>-</sup> cell attempting recombination by this route would kill itself and recombination would be undetectable. It seems that RAD52-independent recombination must proceed by a non-double-strand break mechanism.

The results from the proposed model of rem1 spontaneous mitotic recombination converge with the examination of RAD52-independent recombination. In both studies, recombination can be observed in the absence of RAD52. For rem1, the RAD52-independent recombination may lead to a stimulation of intergenic crossing-over as measured by the appearance of drug-resistance. From the study of recombination at LYS2, heteroallelic intragenic recombination generating prototrophs is detectable. In both cases, and because of the known properties of rad52-1, it appears as if RAD52-independent recombination occurs by a non-double-strand break mechanism, perhaps one similar to the mechanism proposed by Meselson and Radding (156). It should be emphasized that this RAD52-independent recombination system is in no way being proposed as the normal or major mechanism for mitotic recombination. In point of fact, since this recombination system is only detectable under certain circumstances [eg. the triple mutants containing rem1, haploid strain with duplications (110), selected integration of non-replicating plasmids (172), sister-chromatid exchanges (122,184,263), and low level background recombination (Chapter 5 and references 88 and 106)], most normal spontaneous mitotic recombination must proceed with the RAD52 function.

It was noted while examining the rem1 rad4 double mutants that rem1-2 and rad4 exhibited linkage. To determine the position on the current yeast genetic map, the rem1

mutations were crossed with rad3-2. Surprisingly, the only detectable segregants were parental types. Therefore, by this analysis, REM1 and RAD3 are less than one centiMorgan apart.

To determine if the rem1 mutations are alleles of RAD3, a clone complementing rad3-2 UV sensitivity was isolated. This clone complemented all rem1 phenotypes examined. The cloned fragment has the same restriction map as published by Naumovski *et al.* (166,167) and Higgins *et al.* (99) and hybridizes with an internal fragment from pNF3001, a verified RAD3 clone (166). Therefore, on this basis, the rem1 mutations are alleles of the essential function, RAD3.

A prudent question to ask, in retrospect, is why were the rem1 mutations not suspected earlier to be alleles of RAD3? The simple answer is that rem1 mutations are phenotypically very different from known rad3 mutations. For example, the rem1 mutations confer slight UV sensitivity only at very high UV doses (fluence levels which reduce rad3-2 viability by three logs reduce rem1-2 surviving fraction, at most, 20%). Also, the rem1 mutations are hyper-rec, while rad3 mutations produce only a very small stimulation in mitotic recombination (Table 31). As shown in Chapter 2, rem1 rad52 double mutants are inviable. This is not the case for rad3; double mutants like rad3-2 rad52-1 are viable (Table 32). Thus, the rem1 mutations of RAD3 are especially interesting because of their unique phenotypes.

Table 31 Comparison of mitotic recombination in diploid strains containing rem1-2 and rad3-2

Diploid Genotype	RELATIVE RECOMBINATION FREQUENCIES					
	INTRAGENIC					INTERGENIC
	URA3	HIS7	TYR1	LEU1	LYS2	CYH2
$\frac{+}{+}$	1.0	1.0	1.0	1.0	1.0	1.0
$\frac{\text{rem1-2}}{\text{rem1-2}}$	5.4	13	36	24	16	8.1
$\frac{\text{rad3-2}}{\text{rad3-2}}$	1.1	1.6	1.7	--	0.43	2.4
$\frac{\text{rem1-2}}{\text{rad3-2}}$	6.3	11	25	17	12	9.0

Values are normalized to the wild type recombination frequencies presented in Table 17, Chapter 4. The rem1-2 and rad3-2 strains are sibling segregants from the mapping crosses described in Table 21, Chapter 4.

Table 32 Double mutants containing rad3-2 and rad52-1 are viable

VIABLE SPORE GENOTYPE							
DIPLOID GENOTYPE	<u>RAD3</u> <u>RAD52</u>	:	<u>rad3</u> <u>RAD52</u>	:	<u>RAD3</u> <u>rad52</u>	:	<u>rad3</u> <u>rad52</u>
<u>rad3</u> <u>RAD52</u> RAD3 <u>rad52</u>	63		53		50		59

The alleles used were rad3-2 and rad52-1. Sporulation, dissection, germination, and growth conditions are described in the text.

It should be noted that the rem1-2 mutation is dominant to rad3-2 for UV resistance (Figure 34) and hyper-recombination (Table 31). This result is not surprising as rem1 mutations are dominant to wild type as well (80,143).

Are the rem1 mutations consistent with the known molecular properties of RAD3? Both Friedberg's and Prakash's groups have demonstrated that a cloned RAD3 fragment, lacking as much as 74 nucleotides from the mapped 3' end of the gene (at least the 25 C-terminal amino acid residues) can complement for the UV-sensitivity of rad3-1 and rad3-2 (99,165,167). In other words, the carboxyl terminus of this protein may be dispensible for repairing UV damage. One could easily imagine the rem1 mutations of RAD3 to lie in this non-essential region. Since the rem1-2 mutation confers only slight UV sensitivity (at high fluence levels) if the mutation resides in the C-terminal 74 nucleotides, one would predict that it may not confer UV-sensitivity.

Two groups have extensively characterized the RAD3 gene. For all published experiments, the data appears complementary rather than contradictory (68-70,165-168,187, 201). Diploid cells, transformed with a yeast-integrating plasmid (YIp) containing an internal portion of RAD3 (thereby creating a null deletion-duplication allele), segregate 2:2 for viability. The inviable segregants always contain the null allele (Figure 4, Chapter 1). Thus, the RAD3 gene is an essential mitotic function.



Figure 34 The *rem1-2* mutation is dominant to *rad3-2* for UV-sensitivity. UV survival curves were performed as described in Chapter 2. Diploid strains are the same as those described in Table 31. The surviving fraction (percent) is the amount surviving at a given dose relative to the untreated population.

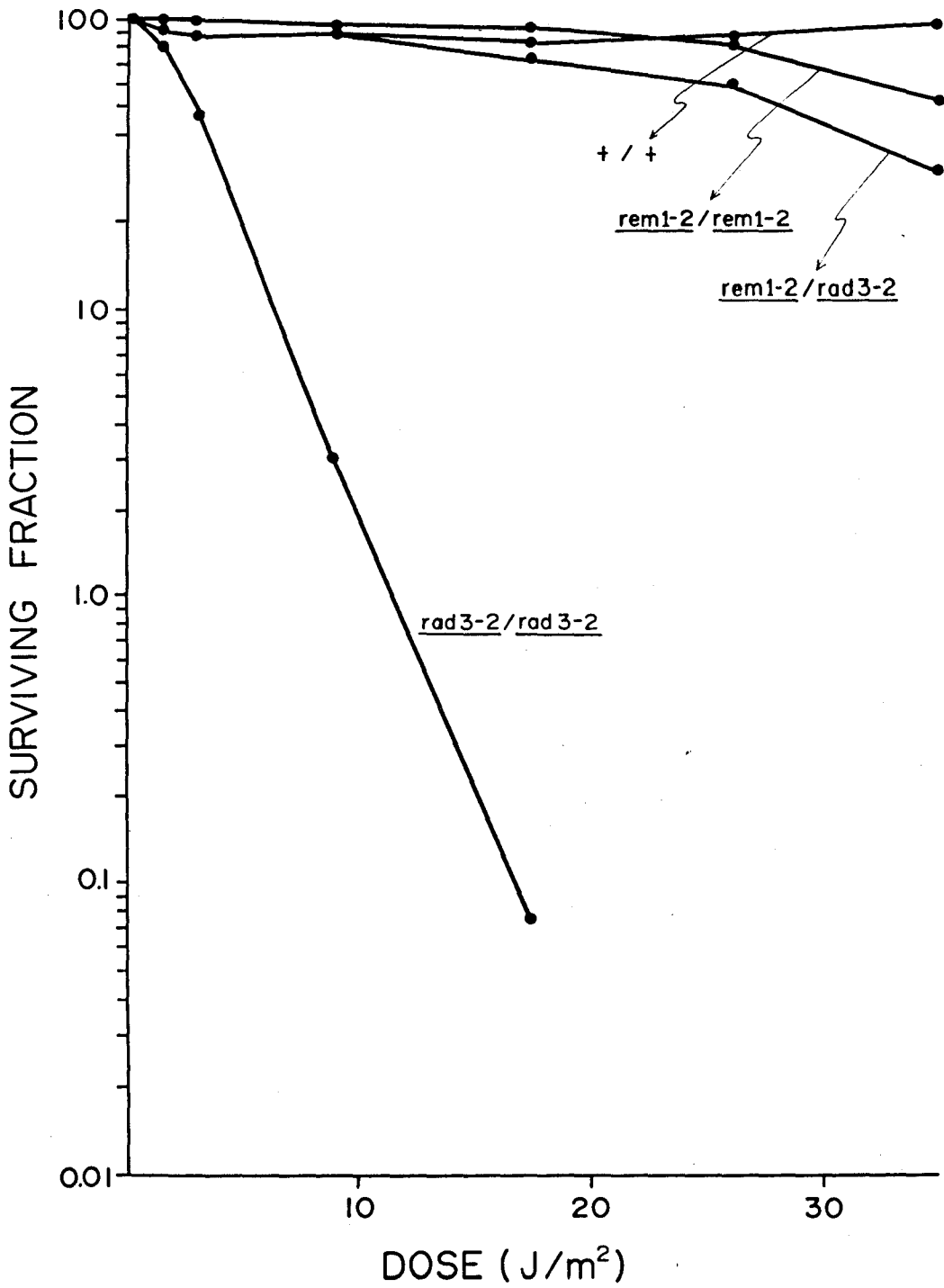

Gene fusion experiments, placing the *E. coli*  $\beta$ -galactosidase gene product under the control of the RAD3 promoter, have shown neither transcription nor translation to be inducible by UV or NQO damage (167). The low level of RAD3 transcription (approximately five transcripts per haploid cell) is not increased by these treatments. One of the fusions created by Naumovski *et al.* (167) truncate the RAD3 protein by 25 amino acids. This fusion, lacking the 3' portion of the coding region, still complemented rad3-2 UV sensitivity; confirming the subcloning results described earlier. In addition to the UV and NQO induction studies, synchronized cells have been examined for the timing of expression (201). The RAD3 transcript is present at steady state levels throughout the cell cycle.

The RAD3 gene and two alleles, rad3-1 and rad3-2, have been sequenced (164). The conceptual translation predicts a protein of 778 amino acids and the alleles are transition mutations at amino acid 236 (glu -> lys) and 461 (gly -> arg), respectively. Friedberg's and Prakash's labs have described an extensive homology comparison of RAD3 with sequence banks (68,187). It has been found that two small regions of RAD3 have interesting homologies. The first region, at amino acid positions 39 - 56, has homology with *E. coli* excision-repair functions uvrA, uvrB, and uvrC (187). Within this 18 amino acid region, the sequence gly-lys-tyr-X-ser is found. This sequence is found in a

number of nucleotide binding proteins and ATPases including mammalian ras proteins, recA, dnaB, SV40 large T antigen, and SIR3 (Silent Information Repressor, involved in S. cerevisiae mating type interconversion) (187). The second region, at positions 592 - 611, has sequence homology with DNA binding proteins (187) capable of assuming an  $\alpha$ -helix-turn- $\alpha$ -helix structure (eg. Phages lambda and 434 repressors). The consensus "turn" sequence (ser-val-ala) is found at positions 599 - 601 (187). Thus, on the basis of the reported sequence homologies, RAD3 could have a nucleotide binding capacity as well as a DNA binding capability. Since neither of the two sequenced alleles (rad3-1 and rad3-2) lie within the homology domains (even though they confer UV sensitivity), site-directed mutagenesis of these two domains should be informative. The protein has a region, defined by integrative transformation, essential for mitotic growth. RAD3 is involved in the incision step of UV repair and has, by DNA homology studies, nucleotide binding and DNA binding regions. An illustration depicting the structural attributes of RAD3 is given in Figure 35.

The RAD3 gene product may have two roles in mitotic growth. One role is non-essential but, because rad3 strains are unable to incise at pyrimidine dimers, is required for excision-repair. The second role, based on its homologies with DNA binding and nucleotide binding proteins, would be essential and possibly related to DNA replication (184).

Figure 35 Schematic diagram of structure-function properties of RAD3. The data is summarized from work by Friedberg's group (68-70,166-168) and Prakash's group (99,165,187,201).

**RAD3 Message**  
(from Northern  
and S1 analysis)

**Gene Structure**  
(from Sequencing)

**Structural Properties**  
(from Gap-Rescue,  
Deletion and  
Homology Studies)

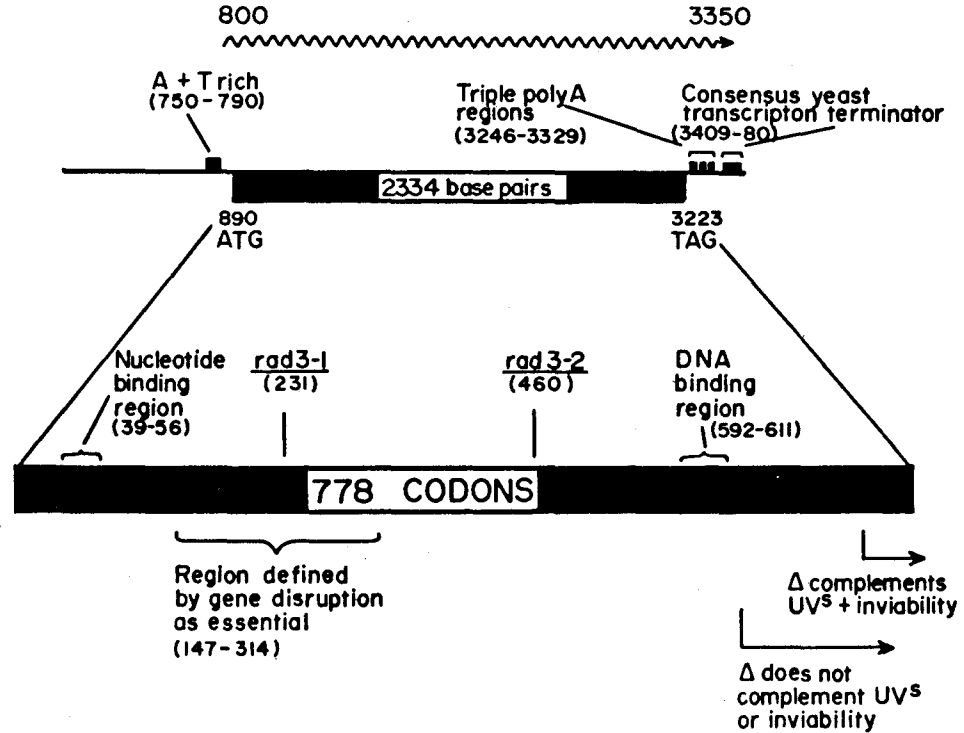

**Splicing :** No splice sites detected in sequence ; S1 nuclease-protected fragments are identical under neutral and alkaline conditions.

**Conceptual Translation :** 778 codons ; Molecular weight calculated at 89,796

**Regulation of Expression :** Less than 5 copies mRNA /cell during log phase ; No increase in  $\beta$ -gal activity or message level after UV or NQO treatment ; Message level is not regulated during cell cycle phases.

Unfortunately, the RAD3 protein has not been purified and precise biochemical studies have yet to be performed.

How do the rem1 mutations fit into the picture? The mutations are dominant to wild type in their action and confer increased recombination and mutation levels. Non-leaky mutations in an essential function, such as gene disruptions, are recessive and lethal. Also, the currently mapped recessive mutations in RAD3 (rad3-1 and rad3-2) do not reside in the regions defined by homology searches as nucleotide and DNA binding domains nor do they have hyper-rec and hyper-mutable phenotypes. Therefore, if RAD3 is involved in replication, leaky mutations in an essential function which, for example, alter the fidelity of polymerization could be predicted as dominant. The role of RAD3 in replication might be in the incorporation of nucleotides into DNA. A leaky mutation in such a function could, therefore, lead to an increase in mismatches which would stimulate recombination and mutation. If the rem1 mutations reside in the terminal portion of the protein, a region shown to be non-essential for repairing UV damage, they would be near the proposed DNA binding region and may affect the function of this region by altering the protein structure. Alternatively, if the rem1 mutations prove to reside elsewhere, they may be leaky mutations in the region defined by gene disruption studies as essential. Regardless, increased replication errors, possibly occurring in

rem1 strains as described earlier, could mimic spontaneous mutations in avoiding the requirement of an error-prone repair system. Increased mismatches could act as a signal for a repair system to recombinationally repair perturbation in a heteroduplex. Since Friedberg's and Prakash's groups have reported RAD3 to have DNA-binding and nucleotide-binding domains (68,187), one can easily imagine these domains as being integral to a replication function.

If the RAD3 gene product does function in replication and increased numbers of mismatches occur in rem1 mutant strains, two models can be imagined for the reduction of gene conversion in rem1 rad1 and rem1 rad4 strains. In the first instance, the RAD1 and RAD4 functions recognize and respond to the rem1-produced DNA lesion. Perhaps, because of the role of the RAD1 and RAD4 gene products in the preincision step of excision-repair (201,203), they may function in a similar fashion for the processing of the rem1 DNA lesion. The absence of these functions, therefore, partially blocks the cell's ability to "process" the lesion. Alternatively, the RAD3, RAD1 and RAD4 functions (and perhaps others) act together in a "repairisome" [using the published terminology of Friedberg (66)]. Mutating RAD3 to create the rem1 mutations, alters the molecular interactions between the gene products and leads to a complex whose properties can be phenotypically measured as hyper-recombination and hyper-mutation. Introduction of a second



mutated molecule to the "repairisome", in this case rad1 or rad4, completely destroys the "repairisome" and a corresponding decrease in gene conversion is observed.

Of these two hypothesis, the former is favored as a more general model. In the simplest case, rem1 mutations lead to a single type of DNA lesion. This lesion leads to increased gene conversion, crossing-over, and mutation. If interactions occur in a molecular complex "repairisome", one might imagine a general reduction in gene conversion, crossing-over, and mutation in rem1 rad1 and rem1 rad4 double mutant strains. Instead, a specific reduction in gene conversion is observed. Also, the interactions between the rem1 mutations and rad1 or rad4 are not allele specific. Unless the two rem1 mutations are identical, which seems unlikely because of the independent isolation of the two mutations, non-allele-specific interactions are inconsistent with the notion of a rem1 "repairisome". However, if the rem1 lesion is differentially processed by cellular functions, mutations in RAD1 or RAD4 could lead to a reduction in gene conversion by altering one of the routes for repair.

## LITERATURE CITED

1. Achwal, C. W., P. Ganguly, and H. S. Chandra. 1984. Examination of the amount of 5-methylcytosine in Drosophila melaogaster by amplified ELISA and photo-acoustic spectroscopy. EMBO J 3:263-266.
2. Adams, R. L. P., and R. H. Burdon. 1983. DNA methylases. p. 119-144. In: S.T. Jacob (ed.), Enzymes of nucleic acid synthesis and modification, vol. 1. DNA enzymes. CRC Press, Cleveland.
3. Adzuma, K., T. Ogawa, and H. Ogawa. 1984. Primary structure of the RAD52 gene in Saccharomyces cerevisiae. Mol. Cell. Biol. 4:2735-2744.
4. Arthur, H. M., and R. G. Lloyd. 1980. Hyper-recombination in uvrD mutants of Escherichia coli K12. Mol. Gen. Genet. 180:185-191.
5. Averbeck, D., E. Moustacchi, and E. Bisagni. 1978. Biological effects and repair of damage photoinduced by a derivative of psoralen substituted at the 3,4 reactive site. Photoreactivity of this compound and lethal effects in yeast. Biochim. Biophys. Acta 518:464-481.
6. Baker, B. S., A. T. C. Carpenter, M. S. Esposito, R. E. Esposito, and L. S. Sandler. 1976. The genetic control of meiosis. Annu. Rev. Genet. 10:53-134.
7. Bale, A., M. d'Alarco, and M. G. Marinus. 1979. Characterization of DNA adenine methylation mutants of Escherichia coli K12. Mutat. Res. 59: 157-165.
8. Barnes, G. and J. Rine. 1985. Regulated expression of endonuclease EcoRI in Saccharomyces cerevisiae: Nuclear entry and biological consequences. Proc. Natl. Acad. Sci. U.S.A. 82:1354-1358.
9. Bekker, M. L., O. K. Kaboev, A. T. Akhmedov, and L. A. Luchinska. 1979. Ultraviolet-endonuclease activity in cell extracts of Saccharomyces cerevisiae mutants defective in excision of pyrimidine dimers. J. Bacteriol. 142:322-324.
10. Birky, C. W., and R. V. Skavaril. 1976. Maintenance of genetic homogeneity in systems with multiple genomes. Genet. Res. 27:249-265.

11. Bisson, L., and J. Thorner. 1977. Thymidine 5'-monophosphate-requiring mutants of Saccharomyces cerevisiae are deficient in thymidylate synthetase. J. Bacteriol. 132:44-50.
12. Boram, W. R., and H. Roman. 1976. Recombination in Saccharomyces cerevisiae: A DNA repair mutation associated with elevated mitotic gene conversion. Proc. Natl. Acad. Sci. U.S.A. 73:2828-2832.
13. Bortz, R. H., M. Lichten, M. Hearn, L. S. Davidow, and J. E. Haber. 1984. Physical monitoring of meiotic recombination in Saccharomyces cerevisiae. Cold Spring Harbor Symp. Quant. Biol. 49:67-76.
14. Borst, P., and G. A. M. Cross. 1982. Molecular basis for Trypanosome antigenic variation. Cell 29:291-303.
15. Brooks, R. H., R. M. Blumenthal, and T. R. Gingeras. 1983. The isolation and characterization of the Escherichia coli DNA adenine methylase (dam) gene. Nuc. Acid Res. 11:837-851.
16. Bruschi, C. V., and M. E. Esposito. 1982. Recombination processes in a sporulation deficient mutant of S. cerevisiae: Role of Holliday structure resolution. Recent Adv. Yeast Mol. Biol. 1:264-268.
17. Bruschi, C. V., and M. E. Esposito. 1983. Enhancement of spontaneous mitotic recombination by the meiotic mutant spoll-1 in Saccharomyces cerevisiae. Proc. Natl. Acad. Sci. U.S.A. 80:7566-7570.
18. Brychcy, T., and R. C. von Borstel. 1977. Spontaneous mutability in UV sensitive excision deficient strains of Saccharomyces. Mutat. Res. 45:185-192.
19. Bull, J. H., and J. C. Wootton. 1984. Heavily methylated amplified DNA in transformation of Neurospora crassa. Nature. 310:701-703.
20. Byers, B., 1981. Cytology of the yeast life cycle. p.59-96. In: J. N. Strathern, E. W. Jones, and J. R. Broach (ed.), The molecular biology of the yeast Saccharomyces. I. Life cycle and inheritance. Cold Spring Harbor Laboratory Press, Cold Spring Harbor, N. Y.
21. Calos, M. P., J. S. Lebkowski, and M. R. Botchan. 1983. High mutation frequency in DNA transfected into mammalian cells. Proc. Natl. Acad. Sci. U.S.A. 80:3015-3019.

22. Carle, G. F., and M. V. Olson. 1984. Separation of chromosomal DNA molecules from yeast by orthogonal-field-alternation gel electrophoresis. *Nuc. Acid Res.* 12:5647-5664.
23. Carpenter, A. T. C. 1979. Synaptonemal complex and recombination nodules in wild type Drosophila melanogaster females. *Genetics* 92:511-541.
24. Cassuto, E., S. C. West, J. Powell, and P. Howard-Flanders. 1981. Genetic recombination: recA protein promotes homologous pairing between duplex DNA molecules without strand unwinding. *Nuc. Acid Res.* 9: 4201-4210.
25. Catcheside, D. G. 1966. A second gene controlling allelic recombination in Neurospora crassa. *Aust. J. Biol. Sci.* 19:1039-1046.
26. Cavenee, W. K., T. P. Dryja, R. A. Phillips, W. F. Benedict, R. Godbout, B. L. Gallie, A. L. Murphee, L. C. Strong, and R. L. White. 1983. Expression of recessive alleles by chromosomal mechanisms in retinoblastoma. *Nature* 316:330-334.
27. Chattoo, B. B., F. Sherman, D. A. Azubalis, T. A. Fjellstedt, D. Mehnert, and M. Ogur. 1979. Selection for lys2 mutants of the yeast Saccharomyces cerevisiae by the use of @-aminoadipate. *Genetics* 93:51-66.
28. Chow, T. K., and M. A. Resnick. 1983. The identification of a deoxyribonuclease controlled by the RAD52 gene of Saccharomyces cerevisiae. p.447-452. In: E. C. Friedberg and B. A. Bridges (ed.), *Cellular responses to DNA damage*. A. R. Liss, N. Y.
29. Clancy, S., C. Mann, R. W. Davis, and M. P. Calos. 1984. Deletion of plasmid sequences during Saccharomyces cerevisiae transformation. *J. Bacteriol.* 159: 1065-1067.
30. Clark, A. J. 1973. Recombination deficient mutants of E. coli and other bacteria. *Annu. Rev. Genet.* 7:67-86.
31. Clark, A. J., and A. D. Margulies. 1965. Isolation and characterization of recombination-deficient mutants of Escherichia coli K12. *Proc. Natl. Acad. Sci. U.S.A.* 53:451-459.
32. Clark, L., and J. Carbon. 1980. Isolation of a yeast centromere and construction of a functional small circular chromosome. *Nature* 287:504-509.

33. Cox, B. S., and J. C. Game. 1974. Repair systems in Saccharomyces. Mutat. Res. 26:257-264.
34. Cox, B. S., and J. M. Parry. 1968. The isolation, genetics, and survival characteristics of ultraviolet light-sensitive mutants in yeast. Mutat. Res. 6:37-55.
35. Davidson, J., M. Heusterspreute, M. Merchez, and F. Brunel. 1984. Vectors with restriction-site banks. I. pJRD158, a 3903-bp plasmid containing 28 unique cloning sites. Gene28:311-318.
36. Dawes, I. W., and I. D. Hardie. 1974. Selective killing of vegetative cells in sporulated yeast cultures by exposure to diethyl ether. Mol. Gen. Genet.131:281-289.
37. De Saint Vincent, B. R., and G. R. Wahl. 1983. Homologous recombination in mammalian cells mediates the formation of a functional gene from two overlapping gene fragments. Proc. Natl. Acad. Sci. U.S.A. 80: 8002-8006.
38. Di Caprio, L., and P. J. Hastings. 1976. Gene conversion and intragenic recombination at the SUP6 locus and the surrounding region in Saccharomyces cerevisiae. Genetics 84:697-721.
39. Doerfler, W. 1983. DNA methylation and gene activity. Annu. Rev. Biochem. 52:93-124.
40. Eckhardt, F., and R. H. Haynes. 1977. Kinetics of mutation induction by ultraviolet light in excision-deficient yeast. Genetics 85:225-247.
41. Edgell, M. H., S. C. Hardies, B. Brown, C. Volivie, A. Hill, S. Phillips, M. Cower, F. Birton, S. Weaver, and C. A. Hutchison III. 1983. Evolution of the mouse beta globin complex locus. p. 1-13, In: M. Nei and R. K. Koehn (ed.), Evolution of genes and proteins.
42. Emerson, S. 1969. Linkage and recombination at the chromosomal level. p. 267-360, In: E. W. Caspari and A. W. Ravin (ed.), Genetic organization 1, Academic Press, N. Y.
43. Eng, R. H. K., R. Drehmel, S. M. Smith, and E. J. C. Goldstein, 1984. Saccharomyces cerevisiae infections in man. Sab. J. Med. Vet. Mycol. 22:403-407.
44. Engels, W. R. 1983. The P family of transposable element in Drosophila. Ann Revu. Genet. 17:315-344.

45. Esposito, M. S. 1978. Evidence that spontaneous mitotic recombination occurs at the two strand stage. Proc. Natl. Acad. Sci. U.S.A. 75:4436-4440.
46. Esposito, M. S., T. M. Dimitros, K. A. Bjornstad, and C. V. Bruschi. 1982. Simultaneous detection of changes in chromosome number, gene conversion and intergenic recombination during mitosis of Saccharomyces cerevisiae: Spontaneous and ultraviolet light induced events. Curr. Genet. 6:5-11.
47. Esposito, M. S., and R. E. Esposito. 1969. The genetic control of sporulation in Saccharomyces. I. The isolation of temperature-sensitive sporulation-deficient mutants. Genetics 61:79-89.
48. Esposito, M. S., R. E. Esposito, M. Armand, and H. O. Halvorson. 1969. Acetate utilization and macromolecular synthesis during sporulation of yeast. J. Bacteriol. 100:180-186.
49. Esposito, M. S., R. E. Esposito, M. Armand, and H. O. Halvorson. 1970. Conditional mutants of meiosis in yeast. J. Bacteriol. 104:202-210.
50. Esposito, M. S., and J. E. Wagstaff. 1981. Mechanisms of mitotic recombination, p. 341-370. In J.N. Strathern, E. W. Jones, and J. R. Broach (ed.), The molecular biology of the yeast Saccharomyces. I. Life cycle and inheritance. Cold Spring Harbor Laboratory Press, Cold Spring Harbor, N.Y.
51. Esposito, R. E., N. Frink, P. Bernstein, and M. S. Esposito. 1972. The genetic control of sporulation in Saccharomyces. I. Dominance and complementation of mutants of meiosis and spore formation. Mol. Gen. Genet. 114:241-248.
52. Esposito, R. E., and S. Klapholz, 1981. Meiosis and ascospore development, p. 211-288. In: J. N. Strathern, E. W. Jones, and J. R. Broach (ed.), The molecular biology of the yeast Saccharomyces. I. Life cycle and inheritance. Cold Spring Harbor Laboratory Press, Cold Spring Harbor, N. Y.
53. Fabre, F. 1978. Induced intragenic recombination in yeast can occur during the G1 mitotic phase. Nature 272:795-798.
54. Fabre, F., and H. Roman. 1977. Genetic evidence for inducibility of recombination competence in yeast. Proc. Natl. Acad. Sci. U.S.A. 74:1667-1671.

55. Fangman, W. L., and V. A. Zakian. 1981. Genome structure and replication, p. 27-58. In: J.N. Strathern, E. W. Jones, and J. R. Broach (ed.), The molecular biology of the yeast Saccharomyces. I. Life cycle and inheritance. Cold Spring Harbor Laboratory Press, Cold Spring Harbor, N.Y.
56. Feher, Z., A. Kiss, and P. Venetiano. 1983. Expression of a modification methylase gene in yeast. Nature302: 266-268.
57. Fischel, R. A., A. A. James, and R. Kolodner. 1981. recA-independent general genetic recombination of plasmids. Nature294:184-186.
58. Fogel, S., and D. D. Hurst. 1963. Coincidence relations between gene conversion and mitotic recombination in Saccharomyces. Genetics 48:321-328.
59. Fogel, S., C. Lox, and D. D. Hurst. 1978. Reversion of the his1 locus of yeast. Genetics 90:489-500.
60. Fogel, S., and R. K. Mortimer. 1969. Informational transfer in meiotic gene conversion. Proc. Natl. Acad. Sci. U. S. A. 62:96-105.
61. Fogel, S., and R. K. Mortimer. 1970. Fidelity of gene conversion in yeast. Mol. Gen. Genet. 109:177-185.
62. Fogel, S., and R. K. Mortimer. 1971. Recombination in yeast. Annu. Rev. Genet. 5:219-236.
63. Fogel, S., R. K. Mortimer, and K. Lusnak. 1981. Mechanisms of meiotic gene conversion, or "wanderings on a foreign strand". p.289-340. In J.N. Strathern, E.W. Jones, and J. R. Broach (ed.), The molecular biology of the yeast Saccharomyces. I. Life cycle and inheritance. Cold Spring Harbor Laboratory Press, Cold Spring Harbor, N.Y.
64. Fogel, S., R. K. Mortimer, K. Lusnak, and F. Tavares. 1979. Meiotic gene conversion: A signal of the basic recombination event in yeast. Cold Spring Harbor Symp. Quant. Biol. 43:1325-1342.
65. Fogel, S., and R. Roth. 1974. Mutations affecting meiotic gene conversion in yeast. Mol. Gen. Genet. 130:189-201.

66. Folger, K. R., E. A. Wang, G. Wahl, and M. Cappechi. 1982. Patterns of integration of DNA microinjected into cultured mammalian cells: Evidence for homologous recombination between injected plasmid molecules. *Mol. Cell. Biol.* 2:1372-1378.
67. Friedberg, E. C. 1984. DNA Repair. W. F. Freeman, San Francisco, CA
68. Friedberg, E. C. 1986. Nucleotide excision repair genes from the yeast Saccharomyces cerevisiae. In: A. Hollaender, P. Hartman, D. Brusick, and D. M. Shankel (ed.), Proc. Int. Conf. Mech. Anticarc. Antimut. (in press).
69. Friedberg, E. C., L. Naumovski, G. A. Pure, R. A. Schultz, W. Weiss, and J. D. Love. 1983. Approaching the biochemistry of excision-repair in eukaryotic cells: The use of cloned genes from Saccharomyces cerevisiae. p. 63-75. In: E. C. Friedberg and B. A. Bridges (ed.), Cellular responses to DNA damage, A. R. Liss, N. Y.
70. Gafner, J., E. M. De Robertis, and P. Philipsen. 1983. Delta-sequences in the 5' non-coding region of yeast transfer RNA genes. *EMBO J.* 2:583-591.
71. Game, J. C. 1983. Radiation-sensitive mutants and repair in yeast. p.109-137. In: J.F.T. Spencer, D.M. Spencer, and A. R. W. Smith (ed.), Yeast genetics. Fundamental and applied aspects. Springer-Verlag, N. Y.
72. Game, J. C., and R. Mortimer. 1974. A genetic study of X-ray mutants in yeast. *Mutat. Res.* 24:281-292.
73. Game, J. C., D. Schild, and R. E. Esposito. 1981. The meiotic phenotype of the rad57-1 mutation. Abstr. In: The molecular biology of yeast, meeting abstracts. Cold Spring Harbor, N. Y.
74. Game, J. C., T. J. Zamb, R. J. Braun, M. Resnick, and R. M. Roth. 1980. The role of radiation (rad) genes in meiotic recombination in yeast. *Genetics* 94:51-68.
75. Gelinas, R. E., P. A. Myers, and R. J. Roberts. 1977. Two sequence specific endonucleases from Moraxella bovis. *J. Mol. Biol.* 114:169-179.
76. Giles, W. H. 1952. Studies on the mechanism of reversion in biochemical mutants of Neurospora crassa. Cold Spring Harbor Symp. Quant. Biol. 26:283-313.



77. Glickman, B. W., and M. Radman. 1980. Escherichia coli mutator mutants deficient in methylation-instructed DNA mismatch correction. Proc. Natl. Acad. Sci. U.S.A. 77: 1063-1067.
78. Glickman, B. W., P. van der Elsen, and M. Radman. 1978. Induced mutagenesis in dam<sup>-</sup> mutants of Escherichia coli: A role for 6-methyladenine residues in mutation avoidance. Mol. Gen. Genet. 163:307-312.
79. Golin, J. E. 1979. The properties of spontaneous mitotic recombination in Saccharomyces cerevisiae. PhD. Thesis, University of Chicago. Chicago, Illinois.
80. Golin, J. E., and M. S. Esposito. 1977. Evidence for joint genic control of spontaneous mutation and genetic recombination during mitosis in Saccharomyces. Mol. Gen. Genet. 150:127-135.
81. Golin, J. E., and M. S. Esposito. 1981. Mitotic recombination: Mismatch correction and replicational resolution of Holliday structures formed at the two strand stage in Saccharomyces. Mol. Gen. Genet. 183:252-263.
82. Golin, J. E., and M. S. Esposito. 1984. Coincident gene conversion during mitosis in Saccharomyces. Genetics 107:355-365.
83. Golin, J. E., and S. C. Falco. 1985. Mitotic coincident gene conversion events in yeast. Genetic 117:s7.
84. Green, M. R., R. Treisman, and T. Maniatis. 1983. Transcriptional activation of cloned human beta-globin genes by viral immediate-early gene products. Cell. 35:137-148.
85. Grier, G. E., and P. Modrich. 1979. Recognition sequence of the dam methylase of Escherichia coli K12 and mode of cleavage of Dpn I endonuclease. J. Biol. Chem. 254:1408-1413.
86. Grivell, A. R., and J. F. Jackson, 1968. Thymidine kinase: Evidence for its absence from Neurospora crassa and some other microorganisms, and the relevance of this to the specific labelling of deoxyribonucleic acid. J. Gen. Micro. 54:307-517.
87. Gross, J. D., J. Grundstein, and E. M. Witkin. 1971. Inviability of recA<sup>-</sup> derivatives of the DNA polymerase mutant of DeLucia and Cairns. J. Mol. Biol. 58:1093-1910.

88. Haber, J. E., and M. Hearn. 1985. rad52-independent mitotic gene conversion in Saccharomyces cerevisiae frequently results in chromosome loss. Genetics 111: 7-22.
89. Hagblom, P., E. Segal, E. Billgard, and M. So. 1985. Intragenic recombination leads to pilus antigenic variation in Neisseria gonorrhoeae. Nature 315:156-158.
90. Hanawalt, P. C., P. K. Cooper, A. K. Ganesan, and C. A. Smith. 1979. DNA repair in bacteria and mammalian cells. Annu. Rev. Biochem. 48:783-836.
91. Hartwell, L. H., S. K. Dutcher, J. S. Wood, and B. Garvik. 1982. The fidelity of mitotic chromosome reproduction in Saccharomyces cerevisiae. Rec. Adv. Yeast Mol. Biol. 1:28-38.
92. Hastings, P. J., S.-K. Quah, and R. C. von Borstel. 1976. Spontaneous mutation by mutagenic repair of spontaneous lesions in DNA. Nature 264:719-722.
93. Hattman, S., C. Kenny, L. Berger, and K. Pratt. 1978. Comparative study of DNA methylation in three unicellular eucaryotes. J. Bacteriol. 135:1156-1157.
94. Hawthorne, D. C., and U. Leupold. 1974. Suppressor mutations in yeast. Curr. Top. Microbiol. Immunol. 64: 1-37.
95. Haynes, R. H., and F. Eckhardt. 1979. Analysis of dose-response patterns in mutation research. Can. J. Genet. Cytol. 21:277-302.
96. Haynes, R. H., and B. A. Kunz. 1981. DNA repair and mutagenesis in yeast, p. 371-414. In: J.N. Strathern, E.W. Jones, and J. R. Broach (ed.), The molecular biology of the yeast Saccharomyces. I. Life cycle and inheritance. Cold Spring Harbor Laboratory Press. Cold Spring Harbor, N.Y.
97. Henaut, A., and M. Luzzati. 1972. Control of recombinational ability of vegetative cells in Saccharomyces cerevisiae. Mol. Gen. Genet. 116:26-34.
98. Herman, G. E., and P. Modrich. 1981. Escherichia coli K12 clones that overproduce dam methylase are hypermutable. J. Bacteriol. 145:644-646.

99. Higgens, D. R., S. Prakash, P. Reynolds, R. Polakowska, S. Weber, and L. Prakash. 1983. Isolation and characterization of the RAD3 genof Saccharomyces cerevisiae and inviability of rad3 deletion mutants. Proc. Natl. Acad. Sci. U.S.A. 80:5680-5684.
100. Hinnen, A., J. B. Hicks, and G. R. Fink. 1978. Transformation of yeast. Proc. Natl. Acad. Sci. U.S.A. 75: 1929-1933.
101. Ho, K. S. Y. 1975. Induction of DNA double-strand breaks by X-rays in a radiosensitive strain of the yeast Saccharomyces cerevisiae. Mutat. Res. 30: 327-334.
102. Ho, K. S. Y., and R. K. Mortimer. 1973. Induction of dominant lethality by X-rays in a radiosensitive strain of yeast. Mut. Res. 20:45-51.
103. Hoekstra, M. F., and R. E. Malone. 1985. Expression of the Escherichia coli dam gene in Saccharomyces cerevisiae: Effect of in vivo adenine methylation on genetic recombination and mutation. Mol. Cell. Biol. 5:610-618.
104. Hoekstra, M. F., and R. E. Malone. 1986. Excision-repair functions in yeast recognize and remove N-6-methyladenine created in vivo. Nature (submitted)
105. Hoekstra, M. F., and R. E. Malone. 1986. Hyper-mutation caused by the rem1 mutation is not dependent on the error-prone or excision-repair groups. Mutat. Res. (in preparation).
106. Hoekstra, M. F., T. M. Naughton, and R. E. Malone. 1986. Properties of spontaneous mitotic recombination occurring in the presence of the rad52-1 mutation of Saccharomyces cerevisiae. Genet. Res.(Camb.) (submitted)
107. Holliday, R. 1968. Genetic recombination in fungi, p. 157 - 174. In: W. J. Peacock and R. D. Brock (ed.), Replication and recombination of genetic material. Aust. Acad. Sci., Canberra.
108. Hotta, Y., and H. Stern. 1974. DNA scission and repair during pachytene in Lilium. Chromosoma 46:279-296.
107. Hurst, D. D., and S. Fogel. 1964. Mitotic recombination and heteroallelic repair in Saccharomyces cerevisiae. Genetics 50:435-458.

110. Jackson, J. A., and G. R. Fink. 1981. Gene conversion between duplicated genetic elements in yeast. *Nature* 292:306-310.
111. Jones, E. W. 1983. Genetic approaches to the study of protease function and proteolysis in *Saccharomyces cerevisiae*. p. 167-194, In: J. F. T. Spencer, D. W. Spencer, and A. R. W. Smith (ed.), *Yeast genetics. Fundamental and applied aspects*, Springer-Verlag, N. Y.
112. Jones, E. W., and G. R. Fink. 1982. The regulation of amino acid and nucleotide biosynthesis in yeast. p.181-300. In: J. N. Strathern, E. W. Jones, and J. R. Broach (ed.), *The molecular biology of the yeast Saccharomyces. II. Metabolism and gene expression*. Cold Spring Harbor Laboratory Press, Cold Spring Harbor, N. Y.
113. Katz, E. R., and V. Kao. 1974. Evidence for mitotic recombination in the cellular slime mold *Dictyostelium discoideum*. *Proc. Natl. Acad. Sci. U.S.A.* 71:4025-4026.
114. Kaufus, A., M. F. Hansen, N. G. Copeland, N. A. Jenkins, B. C. Lampkin, and W. K. Cavenee. 1985. Loss of heterozygosity in three embryonal tumors suggests a common pathogenetic mechanism. *Nature* 316:330-334.
115. Keil, R., and G. S. Roeder. 1984. cis-Acting recombination-stimulating activity in a fragment of ribosomal DNA in *S. cerevisiae*. *Cell* 39:377-386.
116. King, A. M. Q., D. McCahon, W. R. Slade, and J. W. I. Newman. 1982. Recombination in RNA. *Cell* 29:921-928.
117. Klapholz, S. 1980. The genetic control of chromosome segregation during meiosis in yeast. PhD. Thesis, University of Chicago, Chicago, Illinois.
118. Klapholz, S., and R. E. Esposito. 1980a. Isolation of *spol2-1* and *spol3-1* from a natural variant of yeast that undergoes a single meiotic division. *Genetics* 96:567-588.
119. Klapholz, S., and R. E. Esposito. 1980b. Recombination and chromosome segregation during the single division meiosis in *spol2-1* and *spol3-1* diploids. *Genetics* 96: 589-611.
120. Klapholz, S., and R. E. Esposito. 1982. A new mapping procedure employing a meiotic Rec<sup>-</sup> mutant of yeast. *Genetics* 100:387-412.

121. Klapholz, S., C. S. Waddell, and R. E. Esposito. 1985. The role of the SPO11 gene in meiotic recombination in yeast. *Genetics* 110:187-216.
122. Klein, H. L., and T. D. Petes. 1981. Intrachromosomal gene conversion in yeast. *Nature* 289:144-148.
123. Konrad, E. B., and I. R. Lehman. 1975. Novel mutants that accumulate very small DNA replicative intermediates. *Proc. Natl. Acad. Sci. U.S.A.* 72:2150-2154.
124. Koshland, D., J. C. Kent, and L. H. Hartwell. 1985. Genetic analysis of the mitotic transmission of minichromosomes. *Cell* 43:393-403.
125. Kostriken, R., and F. Heffron. 1984. The product of the HO gene is a nuclease: Purification and characterization of the nuclease. *Cold Spring Harbor Symp. Quant. Biol.* 49:9-96.
126. Kostriken, R., J. N. Strathern, A. J. S. Klar, J. B. Hicks, and F. Heffron. 1983. A site-specific endonuclease essential for mating-type switching in Saccharomyces cerevisiae. *Cell* 35:167-174.
127. Kunz, B. A. 1982. The genetic effects of deoxyribonucleotide pool imbalances. *Enviro. Mut.* 4:695-725.
128. Kunz, B. A., and R. H. Haynes. 1981. Phenomenology and genetic control of mitotic recombination in yeast. *Annu. Rev. Genet.* 15:57-89.
129. Lacks, S., and B. Greenberg. 1975. A deoxyribonuclease of Diplococcus pneumoniae specific for methylated DNA. *J. Biol. Chem.* 250:4063-4066.
130. Lacks, S., and B. Greenberg. 1977. Complementary specificity of restriction endonucleases of Diplococcus pneumoniae with respect to DNA methylation. *J. Mol. Biol.* 114:153-168.
131. Lawrence, C. W., and R. Christiansen. 1974. Fine structure mapping in yeast with sunlamp radiation. *Genetics* 76:723-733.
132. Lawrence, C. W., J. W. Stewart, F. Sherman, and R. Christiansen. 1974. Specificity and frequency of ultraviolet-induced reversion of an iso-1-cytochrome c mutant in radiation-sensitive strains of yeast. *J. Mol. Biol.* 85:137-162.

133. Lebkowski, J. S., R. B. DuBridge, E. A. Antell, K. S. Greisen, and M. P. Calos. 1984. Transfected DNA is mutated in monkey, mouse, and human cells. *Mol. Cell. Biol.* 4:1951-1960.
134. Leupold, U. 1959. Studies on recombination in Schizosaccharomyces pombe. Cold Spring Harbor Symp. Quant. Biol. 23:161-170.
135. Lin, F. W., K. Sperle, and N. Sternberg. 1984. Model for homologous recombination during transfer of DNA into mouse L cells: Role for DNA ends in the recombination process. *Mol. Cell. Biol.* 4:1020-1034.
136. Lindegren, C. C. and G. Lindegren. 1943. A new method for hybridizing yeast. *Proc. Natl. Acad. Sci. U.S.A.* 29:306-308.
137. Luria, S. E., and M. Delbruck. 1943. Mutations of bacteria from virus sensitivity to virus resistance. *Genetics* 28:491-511.
138. Ma, C., and R.K. Mortimer. 1983. Empirical equation that can be used to determine genetic map distances from tetrad data. *Mol. Cell. Biol.* 3:1886-1887.
139. Malone, R. E. 1983. Multiple mutant analysis of recombination in yeast. *Mol. Gen. Genet.* 189:405-412.
140. Malone, R. E., and R. E. Esposito. 1980. The RAD52 gene is required for homothallic interconversion of mating types and spontaneous mitotic recombination in yeast. *Proc. Natl. Acad. Sci. U.S.A.* 77:503-507.
141. Malone, R. E., and R. E. Esposito. 1981. Recombinationless meiosis in Saccharomyces cerevisiae. *Mol. Cell. Biol.* 1:891-901.
142. Malone, R. E., J. E. Golin, and M. S. Esposito. 1980. Mitotic versus meiotic recombination in Saccharomyces cerevisiae. *Curr. Genet.* 1:241-248.
143. Malone, R. E., and M. F. Hoekstra. 1984. Relationships between a hyper-rec mutation (reml) and other recombination and repair genes in yeast. *Genetics* 107:33-48.
144. Malone, R. E., and D. Hyman. 1983. Interactions between the MAT locus and the rad52-1 mutation in yeast. *Curr. Genet.* 7:439-447.

145. Malone, R. E., K. B. Jordan, and W. Wardmam. 1985. Extragenic revertants of rad50, a yeast mutation causing defects in recombination and repair. *Curr. Genet.* 9:453-461.
146. Maloney, D., and S. Fogel. 1980. Mitotic recombination in yeast: Isolation and characterization of mutants with enhanced spontaneous mitotic gene conversion rates. *Genetics* 94:825-839.
147. Maniatis, T., E. F. Fritsch, and J. Sambrook. 1982. *Molecular cloning, a laboratory manual*. Cold Spring Harbor Laboratory Press, Cold Spring Harbor, N.Y.
148. Manney, T. R. 1964. Action of a supersuppressor in yeast in relation to allelic mapping and complementation. *Genetics* 50:109-121.
149. Manney, T. R., and R. K. Mortimer. 1964. Allelic mapping in yeast by X-ray induced mitotic reversion. *Science* 143:581-582.
150. Marinus, M. G., and E. B. Konrad. 1976. Hyper-recombination in dam mutants of Escherichia coli k12. *Mol. Gen. Genet.* 149:273-277.
151. Marinus, M. G., and N. R. Morris. 1973. Isolation of deoxyribonucleic acid methylase mutants of Escherichia coli K-12. *J. Bacteriol.* 114:1143-1150.
152. Marinus, M. G., and N. R. Morris. 1975. Pleiotrophic effects of a DNA adenine methylation mutation (dam-3) in Escherichia coli K-12. *Mutat. Res.* 28:15-26.
153. Max, E. E., J. G. Seidman, and P. Leder. 1976. Sequences of five potential recombination sites encoded close to an immunoglobulin K constant region gene. *Proc. Natl. Acad. Sci. U.S.A.* 76:34503454.
154. Maynard-Smith, S., and N. Symonds. 1973. Involvement of bacteriophage T4 genes in radiation repair. *J. Mol. Biol.* 74:33-44.
155. McKee, R. H., and C. W. Lawrence. 1979. Genetic analysis of gamma-ray mutagenesis in yeast. I. Reversion in radiation sensitive strains. *Genetics* 93:361-373.
156. Meselson, M., and C. Radding. 1975. A general model for genetic recombination. *Proc. Natl. Acad. Sci. U.S.A.* 72:358-361.

157. Minet, M., A. M. Grossenbacher-Grunder, and P. Thuriaux. 1980. On the origin of a centromere effect on mitotic recombination. A study in the fission yeast Schizosaccharomyces pombe. Curr. Genet. 2:53-60.
158. Mitchell, M. B. 1955. Aberrant recombination of pyridoxine mutants of Neurospora. Proc. Natl. Acad. Sci. U.S.A. 41:215-220.
159. Modrich, P., and R. J. Roberts. 1982. Type-II restriction and modification enzymes, p. 109-154. In S.M. Linn and R. J. Roberts (ed.), Nucleases. Cold Spring Harbor Laboratory Press, Cold Spring Harbor, N.Y.
160. Montelone, B., S. Prakash, and L. Prakash. 1981. Recombination and mutagenesis in rad6 mutants of Saccharomyces cerevisiae: Evidence for multiple functions of the RAD6 gene. Mol. Gen. Genet. 184:410-415.
161. Morrison, D. P., and P. J. Hastings. 1979. Characterization of the mutator mutation mut5-1. Mol. Gen. Genet. 175:57-65.
162. Mortimer, R. K., and D. Hawthorne. 1969. Yeast genetics, p.385-405. In: D.H. Rose and J. S. Harrison (ed.), The Yeasts, vol. 1. Academic Press, Inc., New York.
163. Mortimer, R. K., and D. Schild. 1980. Genetic map of Saccharomyces cerevisiae. Microbiol. Rev. 44:519-571.
164. Mortimer, R. K., and D. Schild. 1985. Genetic map of Saccharomyces cerevisiae, Edition 9. Microbiol. Rev. 49:181-212.
165. Nagpal, M. L., D. R. Higgins, and S. Prakash. 1985. Expression of the RAD1 and RAD3 genes of Saccharomyces cerevisiae is not affected by DNA damage or during the cell division cycle. Mol. Gen. Genet. 199:59-63.
166. Naumovski, L., G. Chu, P. Berg, and E. C. Friedberg. 1985. RAD3 gene of Saccharomyces cerevisiae: Nucleotide sequence of wild type and mutant alleles, transcript mapping, and aspects of gene regulation. Mol. Cell. Biol. 5:17-26.
167. Naumovski, L., and E. C. Friedberg. 1982. Molecular cloning of eucaryotic genes required for excision repair of UV-irradiated DNA: Isolation and partial characterization of the RAD3 gene of Saccharomyces cerevisiae. J. Bacteriol. 152:323-331.



168. Naumovski, L., and E. C. Friedberg. 1983. A DNA repair gene required for the incision of damaged DNA is essential for viability in Saccharomyces cerevisiae. Proc. Natl. Acad. Sci. U.S.A. 80:4818-4821.
169. Nagylaki, T., and T. D. Petes. 1982. Intrachromosomal gene conversion and the maintenance of sequence homogeneity among repeated genes. Genetics 100:315-337.
170. Ohto, T. 1977. On the gene conversion model as a mechanism for maintenance of homogeneity in systems with multiple genomes. Genet. Res. 30:80-91.
171. Orr-Weaver, T. L., and J. W. Szostak. 1985. Fungal recombination. Microbiol. Rev. 49:33-58.
172. Orr-Weaver, T. L., J. W. Szostak, and R. J. Rothstein. 1981. Yeast transformation: a model system for the study of recombination. Proc. Natl. Acad. Sci. U.S.A. 78:6354-6358.
173. Orr-Weaver, T. L., J. W. Szostak, and R. J. Rothstein. 1983. Genetic applications of yeast transformation with linear and gapped plasmids. p.228-245. In: R. Wu, L. Grossman, and K. Moldave (ed.), Methods in Enzymology 101, Academic Press, N. Y.
174. Patterson, J. T., and M. L. Scribe. 1934. Crossing-over induced by X-rays in Drosophila males. Genetic 19:232-236.
175. Pearlman, D. A., S. R. Holbrook, D. H. Pirkle, and S.-H. Kim. 1985. Molecular models for DNA damage by photoreaction. Science 227:1304-1308.
176. Perkins, D. D. 1949. Biochemical mutants of the smut fungus Ustilago maydis. Genetics 34:607-626.
177. Petes, T. D., and W. L. Fangman, 1972. Sedimentation properties of yeast chromosomal DNA. Proc. Natl. Acad. Sci. U.S.A. 69:1188-1191.
178. Plischke, M., R. Von Borstel, R. Mortimer, and W. Cohn. 1976. Genetic markers and associated gene products in S. cerevisiae. p.767-832. In: G. Fasman (ed.) Handbook of biochemistry and molecular biology, CRC Press, Cleveland, Ohio.
179. Pontecorvo, G., and E. Kafer. 1958. Genetic analysis based on mitotic recombination. Adv. Genet. 9:71-100.

180. Pontecorvo, G., and J. A. Roper. 1953. Diploids and mitotic recombination. *Adv. Genet.* 5:218-233.
181. Prakash, L. 1974. Lack of chemically induced mutations in repair-deficient mutants of yeasts. *Genetics* 78: 1101-1118.
182. Prakash, L. 1976. Effects of genes controlling radiation sensitivity on chemically induced mutation in *Saccharomyces cerevisiae*. *Genetics* 83:285-301.
183. Prakash, L., R. Polakowska, P. Reynolds, and S. Weber. 1983. Molecular cloning and preliminary characterization of the *RAD6* gene of *Saccharomyces cerevisiae*. p.559-568. In: E. C. Friedberg and B. A. Bridges (ed.), *Cellular responses to DNA damage*, A. R. Liss, N. Y.
184. Prakash, L., and S. Prakash. 1980. Genetic analysis of error-prone repair systems in *Saccharomyces cerevisiae*, p. 141-158. In: W. M. Generoso, M. D. Shelby, and F. J. de Serres (ed.). *DNA repair and mutagenesis in eukaryotes*, Plenum, N. Y.
185. Prakash, L., and P. Taillon-Miller. 1981. Effects of the *rad52* gene on sister chromatid recombination in *Saccharomyces cerevisiae*. *Curr. Genet.* 3:247-250.
186. Prakash, S., L. Prakash, W. Burke, and B. A. Montelone. 1980. Effects of the *RAD52* gene on recombination in *Saccharomyces cerevisiae*. *Genetics* 94:31-50.
187. Prakash, S., P. Reynolds, D. R. Higgins, and L. Prakash. 1985. The nucleotide sequence of the *RAD3* gene of *Saccharomyces cerevisiae*: Identification of a potential ATP-binding amino acid sequence and functional analysis of the acidic carboxyl terminal region. *Genetics* (supp)110:54.
188. Proffitt, J. H., J. R. Davie, D. Swinton, and S. Hattman. 1984. 5-Methylcytosine is not detectable in *Saccharomyces cerevisiae* DNA. *Mol. Cell. Biol.* 4:985-988.
189. Pukkila, P., J. Peterson, G. Herman, P. Modrich, and M. Meselson. 1983. Effects of high levels of DNA adenine methylation on methyl-directed mismatch repair in *E. coli*. *Genetics* 104:571-582.

190. Radman, R., R. E. Wagner, B. W. Glickman, and M. Meselson. 1980. DNA methylation, mismatch correction and genetic stability, p. 121-130. In M. Alacevic (ed.), *Progress in environmental mutagenesis*. Elsevier, Amsterdam.
191. Ratzkin, B., and J. Carbon. 1977. Functional expression of cloned yeast DNA in *E. coli*. *Proc. Natl. Acad. Sci. U.S.A.* 74:487-491.
192. Resnick, M. A. 1969. A photoreactivationless mutant of *Saccharomyces cerevisiae*. *Photochem. Photobiol.* 9:307-312.
193. Resnick, M. A. 1976. The repair of double-strand breaks in DNA: A model involving recombination. *J. Theor. Biol.* 59:97-112.
194. Resnick, M. A., J. Boyce, and B. Cox. 1981. Postreplication repair in *Saccharomyces cerevisiae*. *J. Bacteriol.* 146:285-290.
195. Resnick, M. A., T. Chow, J. Nitiss, and J. C. Game. 1984. Changes in chromosomal DNA of yeast during meiosis in repair mutants and the possible role of a deoxyribonuclease. *Cold Spring Harbor Symp. Quant. Biol.* 49:639-649.
196. Resnick, M. A., J. C. Game, and S. Stasiewicz. 1983b. Genetic effects of UV-irradiation on excision-proficient and -deficient yeast during meiosis. *Genetics* 104:603-618.
197. Resnick, M. A., J. N. Kasimos, J. C. Game, R. J. Game, R. J. Braun, and R. Roth. 1981. Changes in DNA during meiosis in a repair-deficient mutant (*rad52*) of yeast. *Science* 212:543-545.
198. Resnick, M. A., and P. Martin. 1976. The repair of double-strand breaks in the nuclear DNA of *Saccharomyces cerevisiae* and its genetic control. *Mol. Gen. Genet.* 143:119-129.
199. Resnick, M. A., S. Stasiewicz. 1983a. Meiotic DNA metabolism in wild type and excision-deficient yeast following UV exposure. *Genetics* 104:583-601.
200. Resnick, M. A., A. Sugino, J. Nitiss, and T. Chow. 1984. DNA polymerases, deoxyribonucleases, and recombination during meiosis in *Saccharomyces cerevisiae*. *Mol. Cell. Biol.* 4:2811-2817.

201. Reynolds, P, S. Weber, and L. Prakash. 1983. Structure and function of the RAD6 gene of yeast. p 214. In: Abs. Twelfth Int. Conf. Yeast Genet. Mol. Biol., Edinburgh, Scotland.
202. Reynolds, R. J., and E. C. Friedberg. 1980. Molecular mechanism of pyrimidine dimer excision in Saccharomyces cerevisiae: Incision of ultraviolet-irradiated deoxy-ribonucleic acid in vivo. J. Bacteriol. 146:692.
203. Reynolds, R. J., J. D. Love, and E. C. Friedberg. 1980. Molecular mechanism of pyrimidine dimer excision in Saccharomyces cerevisiae: Excision of dimers in cell extracts. J. Bacteriol. 147:705-708.
204. Roberts, J. W., C. W. Roberts, and N. L. Craig. 1978. E. coli recA gene product inactivates phage lambda repressor. Proc. Natl. Acad. Sci. U.S.A. 75:4714-4718.
205. Rodarte-Ramon, U. S. 1972. Radiation induced recombination in Saccharomyces: The genetic control of recombination in mitosis and meiosis. Radiat. Res. 49:148-154.
206. Roman, H. 1956. A system selective for mutations affecting adenine metabolism in yeast. C. R. Trav. Lab. Carlsberg 26:299-304.
207. Roman, H. 1957. Studies of gene mutation in Saccharomyces. Cold Spring Harbor Symp. Quant. Biol. 21: 175-185.
208. Roman, H. 1973. Studies of recombination in yeast. Stadler Genet. Symp. 5:35-48.
209. Roman, H., and F. Fabre. 1983. Gene conversion and reciprocal recombination are seperable events in vegetative cells of Saccharomyces cerevisiae. Proc. Natl. Acad. Sci. U.S.A. 80:6912-6919.
210. Roman, H., and F. Jacob. 1959. A comparison of spontaneous and ultraviolet induced allelic recombination with reference to the recombination of outside markers. Cold Spring Harbor Symp. Quant. Biol. 23: 155-160.
211. Rossignol, J. L., N. Paquette, and A. Nicolas. 1979. Aberrant 4:4 asci, disparity in the direction of conversion, and frequencies of conversion in Ascobolus immersus. Cold Spring Harbor Symp. Quant. Biol. 43: 1343-1352.

212. Roth, R. 1973. Chromosome replication during meiosis: Identification of gene functions required for pre-meiotic DNA synthesis. Proc. Natl. Acad. Sci. U.S.A. 70:3087-3091.
213. Roth, R., and S. Fogel. 1971. A selective system for yeast mutants deficient in meiotic recombination. Mol. Gen. Genet. 112:295-305.
214. Rubin, G. M. 1982. Dispersed repetitive DNAs in Drosophila. p.688-710. In: J. A. Shapiro (ed.), Mobile genetic elements, Academic Press, N. Y.
215. Ruby, S. W., and J. W. Szostak. 1985. Specific Saccharomyces cerevisiae genes are expressed in response to DNA-damaging agents. Mol. Cell Biol. 5:75-84.
216. Saeki, T., I. Machida, and S. Nakai. 1980. Genetic control of diploid recovery after gamma-irradiation in the yeast Saccharomyces cerevisiae. Mutat. Res. 73: 251-265.
217. Sancar, A., N. D. Clarke, J. Griswold, W. J. Kennedy, and W. D. Rupp. 1981a. Identification of the uvrB gene product. J. Mol. Biol. 148:63-72.
219. Sancar, A., B. M. Karcinski, D. L. Mott, and W. D. Rupp. 1981b. Identification of the uvrC gene product. Proc. Natl. Acad. Sci. U.S.A. 78:5450-5454.
220. Sancar, A., R. P. Wharton, S. Seltzer, B. M. Karcinski, N. D. Clarke, and W. D. Rupp. 1981c. Identification of the uvrA gene product. J. Mol. Biol. 148:45-62.
221. Saracheck, A. 1954. A comparative study of the retardation of budding and cellular inactivation by ultraviolet radiation in polyploid Saccharomyces with special reference to photoreactivation. Cytologia 19:77-85.
222. Sarkar, S., U. B. Dasgupta, and W. C. Summers. 1984. Error prone mutagenesis detected in mammalian cells by a shuttle vector containing the supF gene of Escherichia coli. Mol. Cell. Biol. 4:2227-2230.
223. Scheckman, R. and P. Novick. 1982. The secretory process and yeast cell surface assembly, p.361-398, In: J. N. Strathern, E. W. Jones, and J. R. Broach (ed.), The molecular biology of the yeast Saccharomyces. II. Metabolism and gene expression. Cold Spring Harbor Laboratory Press, Cold Spring Harbor, N. Y.

224. Schild, D., J. Johnston, C. Chang, and R. K. Mortimer. 1984. Cloning and mapping of Saccharomyces cerevisiae photoreactivation gene PHR1. Mol. Cell. Biol. 4: 1864-1870.
225. Schild, D., B. Konforti, C. Perez, W. Gish, and R. K. Mortimer. 1983a. Isolation and characterization of yeast DNA repair genes. I. Cloning of the RAD52 gene. Curr. Genet. 7:85-92.
226. Schild, D., I. L. Calderon, R. Contopoulou, and R. K. Mortimer. 1983b. Cloning of yeast recombination repair genes and evidence that several are non-essential genes. p.417-427. In: E.C. Friedberg and B.A. Bridges (ed.), Cellular responses to DNA damage, Liss, N. Y.
227. Shapira, G., J. L. Stachelek, A. Letsou, L. Soudak, and R. M. Liskay. 1983. Novel use of synthetic oligonucleotide insertion mutants for the study of homologous recombination in mammalian cells. Proc. Natl. Acad. Sci. U.S.A. 80:4827-4831.
228. Sherman, F., and H. Roman. 1963. Evidence for two forms of allelic recombination in yeast. Genetics 48:255-261.
229. Singer, B. 1982. Mutagenesis from a chemical perspective. In: J.F. Lemontt and W.M. Generoso (ed.), Molecular and cellular mechanisms of mutagenesis. Plenum Press, N. Y.
230. Slonimski, P. R., G. Perrodin, and H. J. Croft. 1968. Ethidium bromide induced mutation of yeast mitochondria: Complete transformation of cells into respiratory deficient non-chromosomal "petites". Biochem. Biophys. Res. Comm. 30:232-239.
231. Snow, R., and C. T. Korch. 1970. Alkylation induced gene conversion in yeast: Use in fine structure mapping. Mol. Gen. Genet. 107:201-209.
232. Southern, E. M., 1975. Detection of specific sequences among DNA fragments separated by electrophoresis. J. Mol. Biol. 98:503-517.
233. Stahl, F. 1979. Genetic recombination. Thinking about it in phage and fungi. W. F. Freeman, San Francisco.
234. Stern, C. 1936. Somatic crossing-over and segregation in Drosophila melanogaster. Genetics 21:625-730.

235. Strausberg, R. L., and R. A. Butow. 1981. Gene conversion at the var1 locus on yeast mitochondrial DNA. Proc. Natl. Acad. Sci. U.S.A. 78:494-498.
236. Streek, R. E. 1980. Single-strand and double-strand cleavage at half-modified and fully modified recognition sites for the restriction nucleases Sau 3A and TaqI. Gene 12:267-275.
237. Struhl, K., D. T. Stinchcomb, S. Scherer, and R. W. Davis. 1976. High frequency transformation of yeast: Autonomous replication of hybrid DNA molecules, Proc. Natl. Acad. Sci. U.S.A. 76:1035-1039.
238. Symington, L. S., L. M. Fogarty, and R. Kolodner. 1983. Genetic recombination of homologous plasmids catalyzed by cell-free extracts of Saccharomyces cerevisiae. Cell 35:805-813.
239. Szostak, J. W. and E. Blackburn. 1982. Cloning yeast telomeres on linear plasmid vectors. Cell 29:245-255.
240. Szostak, J. W., T. L. Orr-Weaver, R. J. Rothstein, and F. Stahl. 1983. The double-strand break repair model for recombination. Cell 33:24-35.
241. Thuriaux, P., M. Minet, P. Munz, A. Ahmad, D. Zabaeren, and U. Leupold. 1980. Gene conversion in nonsense suppressors of Schizosaccharomyces pombe. II. Specific marker effects. Curr. Genet. 1:89-95.
242. Tschumper, G., and J. Carbon. 1980. Sequence of a yeast DNA fragment containing a chromosomal replicator and the TRP1 gene. Gene 10:157-166.
243. Tye, B. K., P. Nyman, I. R. Lehman, S. Hochhauser, and B. Weiss. 1977. Transient accumulation of Okazaki fragments as a result of uracil incorporation into DNA. Proc. Natl. Acad. Sci. U.S.A. 74:154-157.
244. Unrau, P., R. Wheatcroft, B. S. Cox, and T. Olive. 1973. The formation of pyrimidine dimers in the DNA of fungi and bacteria. Bioc. Biophys. Acta 312:626-632.
245. Von Borstel, R. C., and P. J. Hastings. 1977. Mutagenic repair pathways in yeast. In: A. Castellani (ed.). Research in photobiology, Plenum, N. Y.
246. Von Wettstein, D., S. W. Rasmussen, and P. B. Holm. 1984. The synaptonemal complex in genetic segregation. Annu. Rev. Genet. 18:331-413.

247. Wagner, R., and M. Meselson. 1976. Repair tracts in mismatched DNA heteroduplexes. Proc. Natl. Acad. Sci. U.S.A. 73:4153-4139.
248. Wagstaff, J. E., S. Klapholz, C. S. Waddell, and R. E. Esposito. 1985. Meiotic exchange within and between chromosomes requires a common Rec functions in Saccharomyces cerevisiae. Mol. Cell. Biol. 5:3632-3544.
249. Wahl, G. M., M. Stern, and G. R. Stark. 1979. Efficient transfer of large DNA fragment to diazobenxyloxymethyl paper and rapid hybridization using dextran sulfate. Proc. Natl. Acad. Sci. U.S.A. 76:3683-3687.
250. Walker, G. C. 1984. Mutagenesis and inducible responses to deoxyribonucleic acid damage in Escherichia coli. Microbiol. Rev. 48:60-93.
251. Weiffenbach, B., and J. E. Haber. 1981. Homothallic mating type switching generates lethal chromosomal breaks in rad52 strains of Saccharomyces cerevisiae. Mol. Cell. Biol. 1:522-530.
252. Weiffenbach, B., D. T. Rogers, J. E. Haber, M. Zoller, D. W. Russell, and M. Smith. 1983. Deletions and single base-pair changes in the yeast mating type locus that prevent homothallic mating type conversions. Proc. Natl. Acad. Sci. U.S.A. 80:3401-3405.
253. West, S. C., E. Cassuto, and P. Howard-Flanders. 1981. Mechanism of E. coli recA protein directed strand exchange in post-replication repair of DNA. Nature 294:659-662.
254. Whelan, W. L., and D. Soll. 1983. Mitotic recombination in Candida albicans: Recessive lethal alleles linked to a gene required for methionine biosynthesis. Mol. Gen. Genet. 187:477-485.
255. Williamson, M. S., J. C. Game, and S. Fogel. 1985. Meiotic gene conversion mutants in Saccharomyces cerevisiae. I. Isolation and characterization of pms1-1 and pms1-2. Genetics 110:609-646.
256. Whitehouse, H. L. K. 1973. Towards an understanding of the mechanism of heredity, 3<sup>rd</sup> ed., E. Arnold, London.
257. Whitehouse, H. L. K. 1982. Genetic recombination. Understanding the mechanism. J. W. Wiley, N. Y.



258. Wilcox, D. R., and L. Prakash. 1981. Incision and post incision steps of pyrimidine dimer removal in excision-deficient mutants of Saccharomyces cerevisiae. J. Bacteriol. 148:618-623.
259. Wilson, J. H. (ed.). 1985. Genetic Recombination. Benjamin/Cummings , Menlo Park, CA
260. Winge, O. and C. Roberts. 1949. A gene for diploidization in yeast. C. R. Trav. Lab. 24:341.
261. Wood, J. S. 1982a. Effect of Methylbenzimidazole-2-yl-Carbamate on Saccharomyces cerevisiae. Mol. Cell. Biol. 2:1064-1079.
262. Wood, J. S. 1982b. Mitotic chromosome loss by Methylbenzimidazole-2-yl-Carbamate as a rapid mapping method in Saccharomyces cerevisiae. Mol. Cell. Biol. 2:1080-1087.
263. Yasui, A., and M. R. Chevallier. 1983. Cloning of photoreactivation repair gene and excision repair gene of the yeast Saccharomyces cerevisiae. Curr. Genet. 7: 191-194.
264. Zamb, T., and T. Petes. 1981. Unequal sister-strand recombination within yeast ribosomal DNA does not require the RAD52 gene product. Curr. Genet. 3:125-132.
265. Zieg, J., M. Hilmen, and M. Simon. 1978. Regulation of gene expression by site-specific inversion. Cell 15: 237-244.
266. Zinn, A.R., and R. A. Butow. 1984. Kinetics and intermediates of yeast mitochondrial DNA recombination. Cold Spring Harbor Symp. Quant. Biol. 49:115-120.

APPROVAL SHEET

The dissertation submitted by Merl Francis Hoekstra has been read and approved by the following committee:

Robert E. Malone, Ph.D., Director  
Assistant Professor, Microbiology, Loyola  
(Assistant Professor, Biology, University of Iowa)

Tadayo Hashimoto, M. D., Ph. D.  
Professor, Microbiology, Loyola

Steven K. Farrand, Ph. D.  
Associate Professor, Microbiology, Loyola

Robert V. Miller, Ph. D.  
Professor, Biochemistry, Loyola

Robert Elder  
Assistant Professor, Molecular Genetics and Cell  
Biology, University of Chicago

The final copies have been examined by the director of the dissertation and the signature which appears below verifies the fact that any necessary changes have been incorporated and that the dissertation is now given final approval by the committee with reference to content and form.

The dissertation is therefore accepted in partial fulfillment of the requirements for the degree of Doctor of Philosophy.

2/21/86  
Date

Robert E. Malone  
Director's Signature