

Utah State University

DigitalCommons@USU

Undergraduate Honors Capstone Projects

Honors Program

5-2017

Design Baseline Document: Mini Baja Frame

Michael Luke Scoggins
Utah State University

Follow this and additional works at: <https://digitalcommons.usu.edu/honors>



Part of the [Mechanical Engineering Commons](#)

Recommended Citation

Scoggins, Michael Luke, "Design Baseline Document: Mini Baja Frame" (2017). *Undergraduate Honors Capstone Projects*. 208.

<https://digitalcommons.usu.edu/honors/208>

This Thesis is brought to you for free and open access by the Honors Program at DigitalCommons@USU. It has been accepted for inclusion in Undergraduate Honors Capstone Projects by an authorized administrator of DigitalCommons@USU. For more information, please contact digitalcommons@usu.edu.



DESIGN BASELINE DOCUMENT: MINI BAJA FRAME

by

Michael Luke Scoggins

**Thesis submitted in partial fulfillment
of the requirements for the degree**

of

Departmental Honors

in

**Mechanical Engineering
in the Department of Mechanical and Aerospace Engineering**

Approved:

Capstone Mentor
Jackson Graham

Departmental Honors Advisor
Dr. V. Dean Adams

Director of University Honors Program
Dr. Kristine Miller

UTAH STATE UNIVERSITY
Logan, UT

Spring 2017

Acknowledgements

No student succeeds in a vacuum; this is especially true from my experience with the Utah State University College of Engineering and Honors Program. I would like to extend my thanks to all the faculty, friends, and mentors who have helped me through the last several years. I would like to thank Dr. Heng Ban, my research mentor, for believing in my abilities and pushing me to achieve great things. I would like to thank my capstone mentors, Jackson Graham and Spencer Wendel, for applying their professional criticism to my capstone work so that I could produce a higher quality product. I would also like to thank the Utah State University College of Engineering and Honors Program for providing a guidance and support system to help students through difficult times. Finally, I am grateful to the friends and acquaintances with whom I've shared this learning experience.

Design Baseline Document

Mini Baja – Frame Team

Austin Jelitto

Braden Beckstrom

Leonard Francis

Michael Luke Scoggins

Robert Hansen



Mechanical & Aerospace
ENGINEERING

PROJECT ROLES AND RESPONSIBILITIES

PROJECT ROLE	NAME	DOCUMENT ROLE: SECTIONS COVERED
LEAD ENGINEER	Michael Luke Scoggins	Author: Sections 1, 3, 4, 7.2, 9.3, 9.4; Reviewer: Sections 5.2, 8, 9.5
SYSTEMS ENGINEER	Austin Jelitto	Author: Sections 6, 9.2, 9.6 Appendix C; Reviewer: Sections 3, 9.3, 9.4
NOTEKEEPER	Braden Beckstrom	Author: Sections 2, 7.1, 8, 9.1, 9.5 Appendix B; Reviewer: Sections 1, 4
RULES EXPERT	Leonard Francis	Author: Section 5.1; Reviewer: Sections 6, 7.1, 9.2, 9.6
P-CARD HOLDER	Robert Hansen	Author: Section 5.2, Appendix A; Reviewer: Sections 2, 5.1, 7.2, 9.1

CONTENTS

1	Problem Definition.....	1
1.1	Overview	1
1.2	Engineering Requirements.....	1
1.3	Goals	4
1.4	Fundamental Assumptions	5
1.5	Governing Standards.....	5
1.6	Deliverables.....	6
2	Conceptual Analysis	7
2.1	Design Space	7
2.2	Concepts Considered	7
2.3	Options Analysis.....	11
3	System Overview.....	14
4	Frame Structure Subsystem.....	14
5	Integration Subsystem	15
5.1	Drivetrain Mounting	15
5.2	Suspension Mounting	15
6	Safety Subsystem	16
7	Controls Subsystem.....	19
7.1	Throttle and Brake Pedals.....	19
7.2	Steering Column.....	20
8	Manufacturing Plan.....	23
9	Special Topics	24
9.1	Safety	24
9.2	Bill of Material (BOM) Overview and Budget	24
9.3	Lessons Learned	26
9.4	Recommended Future Work.....	27

APPENDICES

- A. Drawing Package
- B. Equivalent Tube Strength/Stiffness Calculations
- C. 2017 Baja SAE Rules

1 PROBLEM DEFINITION

1.1 OVERVIEW

1.1.1 Objective

Our objective as the Mini Baja Frame team is to design and implement a prototype vehicle frame that is both cost-effective and competitive in an all-terrain racing environment. This vehicle must be able to endure the trials of the Society of Automotive Engineers (SAE) Mini Baja competition. An effective frame will contribute to the complete Utah State University Mini Baja Team objectives by efficiently integrating the components produced by the drivetrain and the suspension engineers. In addition, this competition is a means for us as students to gain valuable, tangible experience in the engineering design process.

1.1.2 Customer

Our target customer is Jackson Graham, a representative of Utah State University. Through our success in this design process, we would positively represent the quality of education and training received by students of this university.

1.1.3 Target End User

The end users of this product include the students working on the USU Mini Baja teams, future student competitors, and the recreational vehicle industry at large.

1.1.4 Interfacing Systems and Users

Our frame design will interface with the products of the drivetrain and the suspension teams in order to fulfill the competition objectives. Ease of integration is paramount to our success. This will be achieved through constant communication and collaboration with the design teams mentioned above and our customer. The frame will also interface with the driver through its safety mechanisms, controls, and structural support.

1.1.5 Issues of Primary Concern

The frame of an off-road recreation vehicle is the first line of defense against injury. Because the 2017 Baja SAE Rules were created to ensure the safety of the driver, adherence to these rules is the primary concern of this project.

1.2 ENGINEERING REQUIREMENTS

The 2017 Baja SAE Rules provide a reference point for many of the engineering requirements discussed in this section. The rules document will be discussed further in Section 2.1. For the full requirements enforced by the SAE Baja administration, see Appendix C.

1.2.1 The vehicle weight shall not exceed 450 lbs. The frame weight shall be less than 130 lbs.

Source: Due to the limited power of the engine and the dynamic nature of the competition events, weight is a driving factor for performance.

Fulfillment Strategy: Design concepts that exceed the defined weight limits will be rejected. Pre-fabrication weights will be calculated using solid modeling software. Post-fabrication weight will be measured using scales. Weight budgeting by subsystem is outlined below.

1.2.1.1 The skeletal frame, including primary and secondary tube members, shall not exceed 70 lbs.

1.2.1.2 Driver restraints and safety equipment shall not exceed 20 lbs.

1.2.1.3 Body panels, firewall, and interface points shall not exceed 20 lbs.

1.2.1.4 Driver controls, including steering column, throttle pedal, and brake pedal, shall not exceed 20 lbs.

1.2.2 The prototype frame shall adhere to a fiscal budget of \$5,000.

Source: The frame design team has been allotted a limited budget for the fulfillment of its responsibilities. Those responsibilities include the purchasing of all raw materials, accessories, and safety equipment for the creation of the prototype frame.

Fulfillment Strategy: Purchases will be prioritized according to the weight of the engineering requirements. The P-card holder, who may decide to cut spending to less important subsystems if necessary, will track the subsystem budgets. Concepts that threaten the budget limits will be studied critically. Fiscal budgeting by subsystem is outlined below.

1.2.2.1 The cost of the frame structure shall not exceed \$1700.

1.2.2.2 The cost of restraints and driver safety equipment shall not exceed \$1200.

1.2.2.3 The cost of throttle, brake, and steering controls shall not exceed \$500.

1.2.2.4 The cost of body panels, firewall, and interface points shall not exceed \$500.

1.2.2.5 The cost of electronics, including kill-switches, reverse lights, and transponders, shall not exceed \$300.

1.2.2.6 Discretionary expenses for all subsystems shall not exceed \$1000.

- 1.2.3 The seat and driver controls shall accommodate individuals between 5'2"-6'4" in height and 130-250 lbs. in weight.

Source: As the prototype of a potential production vehicle, this design must accommodate off-road enthusiasts of many sizes.

Fulfillment Strategy: Seating, pedal, and steering wheel arrangement will be designed with ergonomics in mind and verified before integration using multiple test drivers.

- 1.2.4 The seat and harness shall prevent the driver from sliding under 2 Gs of lateral acceleration.

Source: We expect to navigate multiple 8-foot radius turns at approximately 15 mph. During these turns, driver instability or discomfort would negatively affect focus and performance.

Fulfillment Strategy: Since a five-point harness is required per the 2017 Baja SAE Rules, the driving design consideration for lateral support will be the seat. Therefore, seat concepts will be compared to one another in terms of available bracing.

- 1.2.5 The engine and continuously variable transmission (CVT) shall be removable for inspection or repair.

Source: In the case of mechanical failure during testing or competition, it is important to be able to remove the engine and CVT without taking the time to disassemble and reassemble parts of the vehicle.

Fulfillment Strategy: The arrangement of drivetrain components will be related to the shape and size of the rear frame geometry so they can be removed through the side.

- 1.2.6 The vehicle shall have a track width of 60 in.

Source: Competition requirements limit the overall width to 64 in. A larger track width decreases the risk of rollover and allows for more wheel travel, however, a smaller track width increases maneuverability by decreasing turning radius.

Fulfillment Strategy: The frame width in the front and rear of the vehicle will be determined in conjunction with the suspension team to meet the width requirement.

- 1.2.7 The vehicle shall withstand a drop from a height of 6 ft. with a pitch and a roll of 30 degrees (landing on one wheel).

Source: During dynamic competition events, we expect the vehicle to experience jumps and falls which would cause stress on the frame and on the suspension components, and mechanical failure during one of these events would be difficult to recover from.

Fulfillment Strategy: The frame structure will be designed to SAE specifications found in 2017 Baja SAE Rules. Testing will be performed to ensure the strength of the welds before fabrication begins. Plates, brackets, and other mounting points will be designed with consideration for

impact loads similar to a fall from three feet. Finally, the vehicle will be dropped from this height with a full payload.

1.3 GOALS

1.3.1 The team should be supported by at least two industry sponsorships.

Source: As stated above, purchasing priority will be given to meeting all of the competition and safety requirements necessary to participate. All remaining money will be used to further improve the performance of our Baja racer. Sponsorships will allow us to allocate more money to the improvement of performance.

Fulfillment Strategy: There are many opportunities for industry sponsorship throughout Cache Valley and beyond. We will inquire with vendors and automotive-related companies to see if any would be interested in sponsoring part of the Baja car.

1.3.2 Raw materials should be available within two weeks of order placement.

Source: Due to the limited time associated with the design space, the quick acquisition of raw materials for the frame will greatly aid in the manufacturing process. Time spent waiting for irregular or non-commercial-off-the-shelf parts would be better spent doing fabrication.

Fulfillment Strategy: When obtaining quotes from manufacturers, we will inquire about acquisition lead times. The estimates given will be approximate but they will give us a reference time to use for decision-making.

1.3.3 The frame weight should be below 110 lbs.

Source: Requirement 1.2.1 describes the need for a light-weight frame. Additional weight savings, if possible, can further improve performance.

Fulfillment Strategy: We will factor weight heavily into all design considerations. Using the mass properties in SolidWorks, we will remove unnecessary tubing footage to reduce the weight of the frame. We will select geometries that require less added material and use spring scales to determine if this goal is met.

1.3.4 Machining and assembly plans should be feasible for students using Utah State resources.

Source: Due to the design space and competition guidelines restricting outsourced fabrication, ease of manufacturability is key to completing our prototype on time. Due to our lack of experience, complexities in the manufacturing processes will reflect negatively on the prototype quality.

Fulfillment Strategy: We will talk with people who have experience working on similar projects to gain insight into the difficulty of different processes. We will avoid processes or concepts that require extensive training or expensive machining tools whenever possible.

1.3.5 The prototype should place in the top 25% of the competition field.

Source: Without recent experience to influence our design it is unrealistic to expect to win the competition. Since future Mini-Baja teams at Utah State University will likely base their designs off this model, a top 25% would give them a good starting point in future years.

Fulfillment Strategy: Part of the SAE competition is the judging and scoring of each team based on many aspects of their design such as the cost of production, design evaluation, sales presentation, and the performance in the dynamic events. At the end of the competition, each team is ranked according to their total accumulated points in all of the events. The team will study the events and design documents to determine the best strategy for success (in terms of lightness, maneuverability, cost effectiveness, etc.).

1.4 FUNDAMENTAL ASSUMPTIONS

We assume that the safety regulations imposed by 2017 Baja SAE Rules are sufficient to guarantee the well-being of the driver. In addition, we assume that the operators of this prototype or any derivative thereof will be responsible and make use of the safety equipment. We assume that the work of our team and the suspension and drivetrain teams will be sufficient for the vehicle to complete the competition without experiencing mechanical failure, except by unforeseen accident.

1.5 GOVERNING STANDARDS

The 2017 Baja SAE Rules define specific standards for safety and performance (see Appendix C). As such, these will be the primary source of guidance during the design process.

1.6 DELIVERABLES

- System Requirements Report, 09/13/2016
- Conceptual Design Review, 09/26/2016
- Preliminary Analysis Report, 10/18/2016
- Preliminary Design Report, 10/22/2016
- Preliminary Design Review, 10/24/2016
- Preliminary Test Plan, 11/01/2016
- Critical Design Report, 12/04/2016
- Critical Design Review, 12/05/2016
- Preliminary Test Report, 12/09/2016
- SAE Cost Report, 03/02/2017
- Engineering Prototype, 03/03/2017
- SAE Design Report, 03/16/2017
- Competition/Final Design Review, 04/27/2017
- Final Design Report, 05/05/2017

2 CONCEPTUAL ANALYSIS

2.1 DESIGN SPACE

In many ways, the design space of the Mini Baja frame is quite limited. Strict guidelines are in place for most aspects of the vehicle including material quality, vehicle geometry, and quality of assembly. Concepts that would prevent the vehicle from passing a technical inspection are dismissed immediately.

Possible solutions are compared against one another by their ability to solve the underlying design challenge: to develop a fast and robust off-road vehicle that will place in the top quarter of the competition field.

2.2 CONCEPTS CONSIDERED

The concepts considered here are derived through a combination of strategies including historical research of competitive Baja cars, research of existing solutions in the motorsports industry, and consideration of the 2017 Baja SAE Rules. Typically, competitive entries in the SAE Baja competition and popular commercial off-road vehicles focus on lightness and driver experience.

Other aspects of the design that are not included in the conceptual analysis are non-critical, such as the placement and fabrication of pedals, routing of brake lines, brands of safety equipment, etc. The selection of these items does not offer a competitive advantage over the selection of similar items or items sold by other brands. Under these circumstances, the cheapest item that meets SAE requirements will be purchased. Some are driven by more important decisions. For example, harness mounting points depend on the position and shape of the driver seat and the frame geometry.

2.2.1 Seat Concepts

The driver seat is an important part of the driver experience which directly affects performance when operating the vehicle. In addition to providing protection in case of a crash or rollover, the seat will help restrain the driver when significant dynamic forces are felt due to cornering or jumps. This helps reduce driver fatigue and allows more focus to be directed to controlling the vehicle.

The two most common seat designs are bucket seats and full-backed seats. The bucket seat is more common on smaller vehicles such as Go-Karts and consists of a back that extends anywhere from just above the lower back to just below the armpits. This helps to reduce the weight and accommodate many sizes of drivers. The full-backed seat is similar to the bucket seat in the lower half design but with a back that extends behind the head. This helps to restrain the head while driving, increasing the safety and comfort of the driver.

For both bucket and full-backed seats, there are products on the market worth considering. However, it is also possible for us to produce a custom seat design through Utah State University resources. The relative advantage of each is not immediately clear, so we will consider each solution concept in detail. Figures 1-5 show the seats considered in this decision analysis.

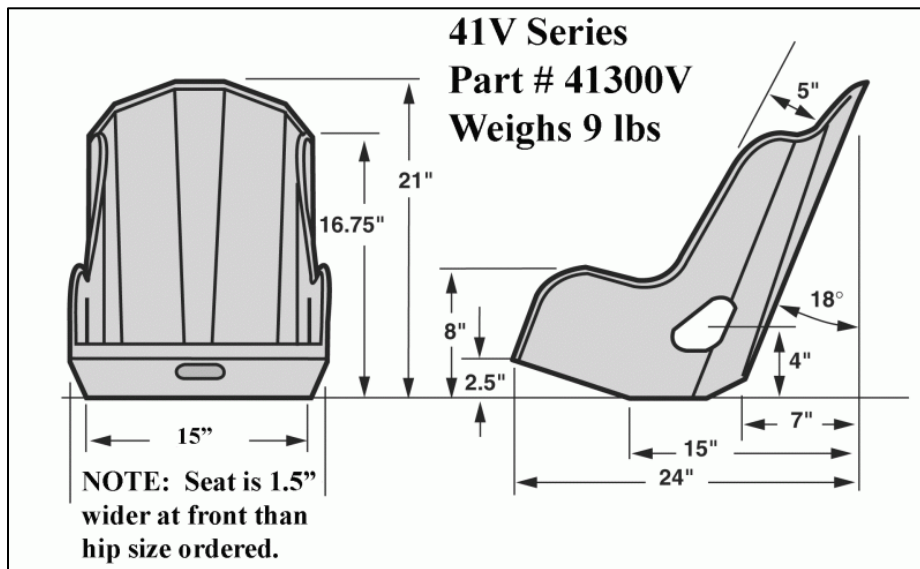

Figure 1. Custom bucket seat

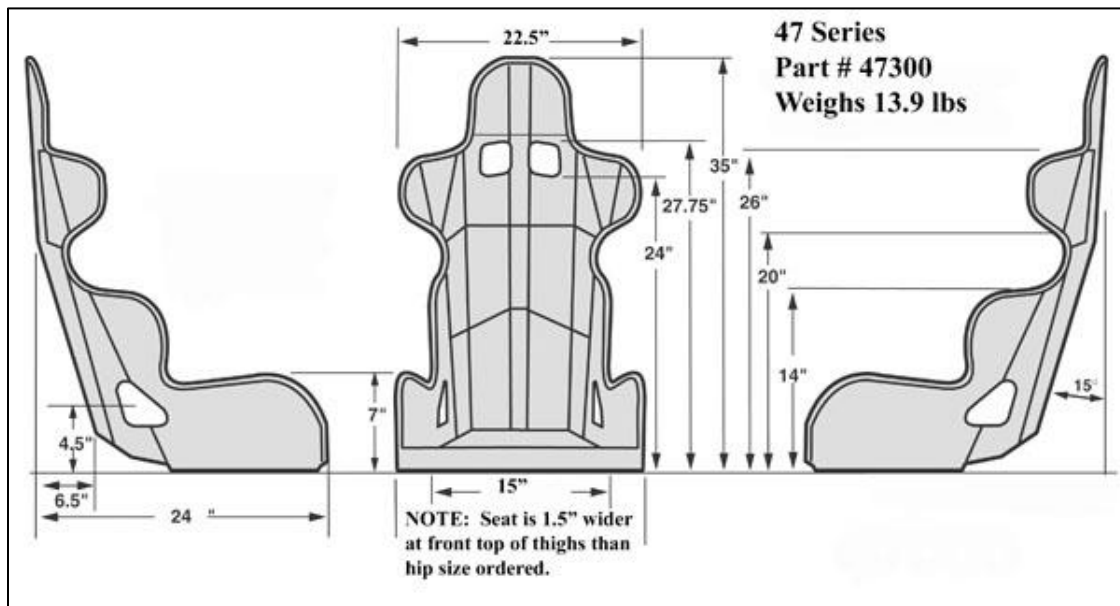



Figure 2. Custom Full-backed seat

← Back to search results for "bucket racing seats"



Click to open expanded view

Jaz Products 100-140-01 Pro High Back Poly Bucket Seat

by Jaz
★★★★★ 1 customer review

Price: **\$95.48** FREE Shipping for Prime members once available [Details](#)

Note: Available at a lower price from [other sellers](#), potentially without free Prime shipping.

Only 6 left in stock.
Ships from and sold by Amazon.com.

- Seat
- Pro High Back
- Non-Reclining
- Side Bolsters

[See more product details](#)

15 new from **\$81.00**

[Report incorrect product information.](#)

Figure 3. Commercial Bucket seat

← Back to search results for "racing seats"



Roll over image to zoom in

RCI 8000S Poly Baja Hghbck Seat Blk

by RCI
★★★★☆ 9 customer reviews | 7 answered questions

Price: **\$55.25 & FREE Shipping**

Note: Not eligible for Amazon Prime. Available with free Prime shipping from [other sellers on Amazon](#).

In Stock.
Estimated Delivery Date: Sept. 28 - Oct. 3 when you choose Standard at checkout.
Ships from and sold by [Everything-Aftermarket](#).

- 20" wide x 33" tall
- 10 lbs.
- 18 Degree Layback
- Lightweight double-wall poly construction
- Fixed mounts included and installed

[See more product details](#)

28 new from **\$55.25**

[Report incorrect product information.](#)

This item's packaging will indicate what is inside and cannot be hidden.

Figure 4. Commercial Full-backed Seat

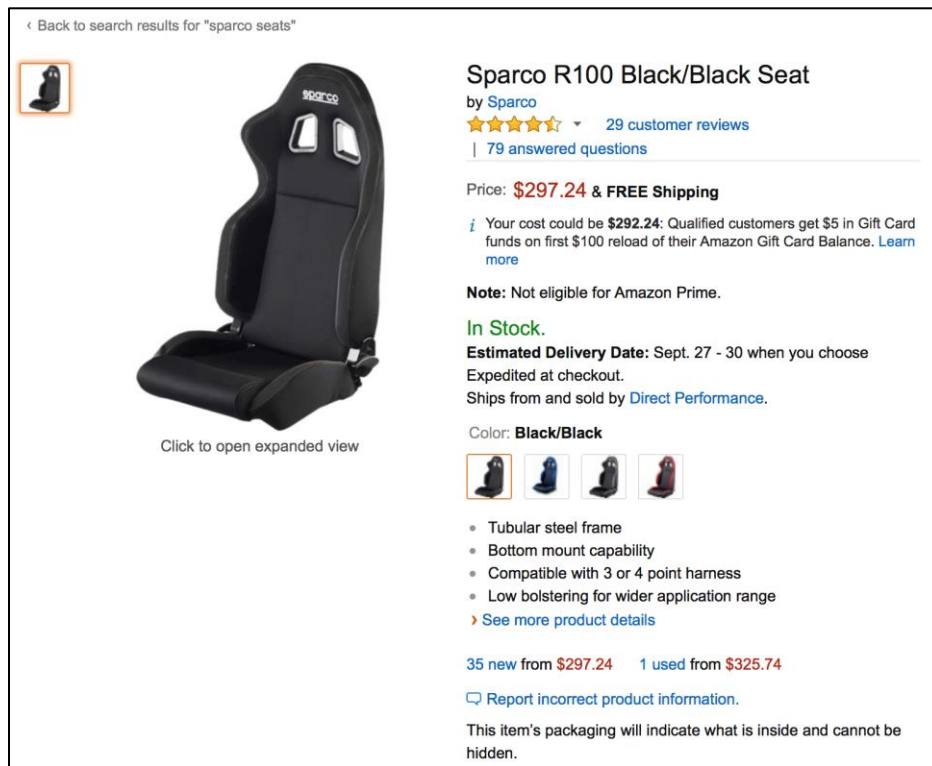

Figure 5. Sparco Full-backed Seat

2.2.2 Frame Material/Grade of Carbon Steel

One of the main components that will ensure driver safety and competition success is the type of steel selected for the fabrication of the frame. This choice will be made based on three criteria: cost, availability, and weight. These criteria are chosen to help ensure competitiveness, safety, and adherence to the 2017 Baja SAE Rules. We researched two grades of steel based on previous experience and guidance from experienced machinists: 1018 mild steel and 4130 Chromalloy steel.

2.2.3 Firewall Material Concepts

We considered a variety of potential firewall materials that would meet the SAE requirements. These requirements include a thickness of at least 0.02 in. and a metal composition. With each material, we compared both price and weight with the goal of finding a material that is lightweight and inexpensive. The information for each concept is sourced from onlinemetals.com.

Table 1. Conceptual Firewall Materials

Material	Dimensions	Price	Weight/Square Foot (lb)
Titanium Grade 2	0.02"X36"X48"	\$316.19	0.47
Zinc	0.02"X36"X48"	\$106.09	0.75
Stainless Steel Treadplate 304	0.024"X36"X48"	\$172.42	0.98
Aluminum 2024 O Clad	0.025"X36"X48"	\$35.42	0.36
Aluminum 3003 H14	0.025"X36"X48"	\$29.31	0.36
Aluminum 5052 H32	0.02"X36"X48"	\$19.26	0.28
Aluminum 6061 T6	0.02"X36"X48"	\$44.99	0.28

2.3 OPTIONS ANALYSIS

2.3.1 Seat Selection

A critical aspect of seat design is weight reduction. The most obvious way to reduce the weight would be through effective material selection. Carbon fiber may be the best material for this application, and it is readily available through Utah State University's composites laboratory. A lightweight and strong seat can be created from a simple layup of alternating fiber directions.

One drawback with designing and manufacturing our own seat out of carbon fiber would be the skills and experience necessary to make a quality product. The process is quite involved, and it would take time and practice to produce an acceptable seat. The biggest advantage would be the design freedom and the weight reduction. The main fault with purchasing a seat would be the fact that we have no design freedom or control over the weight of the product, but we would have no need to worry about problems in the manufacturing processes.

The Sparco full seat is given for reference. As a fully assembled and ready-to-install racing seat, it offers the most comfort and is most resembling that of a seat found in competitive, full-sized racing applications. After further research, it became clear that the Sparco seat was too expensive and too heavy for our requirements and goals when compared to unpadded seats or a custom seat manufactured by the Mini Baja Frame Team.

To assist with the decision-making process, we constructed a decision matrix (Table 2) comparing the concepts per their relative weight, cost, and comfort. Weight and cost point allocations are normalized by the heaviest and most expensive concepts, respectively. In addition, weight is considered three times as important as cost or comfort (each of which has a maximum range of three points). This is a consequence of the vehicle's restriction to a 10 HP engine and the nature of the dynamic events at the competition. For the seat comfort, a maximum of one point is awarded to a seat containing each of the following: side bolsting, head support, and cushioning. Seats missing any of these components receive a score less than unity. The resulting scores show that the in-house fabricated bucket seat is the best option for this design.

Table 2. Decision Matrix for Seat Concepts

Requirements	Weight	Concepts				
		Purchased Full Seat	Purchased Bucket Seat	In-House Full Seat	In-House Bucket Seat	Sparco Full Seat
1.2.1.2 (Weight)	9	0.1	0.25	0.35	0.55	0
1.2.2.2 (Cost)	3	0.79	0.63	1	1	0
1.2.4 (Bracing)	3	0.66	0.33	0.66	0.33	1
	Total Score:	5.25	5.13	8.13	8.94	3

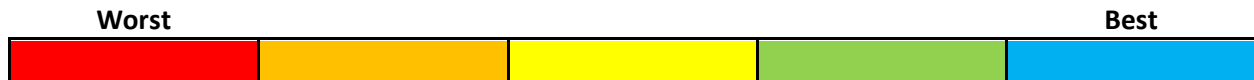

2.3.2 Tubing Selection

1018 steel, a common form of mild carbon steel, has a nominal carbon content of 0.18%. A nominal carbon content of at least 0.18% is required for the roll cage and bracing materials (SAE rule booklet, pg. 27). The yield strength of 1018 steel is 365 MPa, and the modulus of elasticity is assumed to be 205 GPa for all steels (SAE rule booklet, pg. 27). 1018 steel can be purchased locally from Ipaco Inc. and is sold at approximately \$1.50 per foot for 1.0 in. diameter, 0.120 in. thick tubing. This steel is readily available with no lead time.

4130 steel, commonly referred to as “Chromalloy,” has a nominal carbon content of 0.28%. Like 1018 steel, Chromalloy also has a sufficient carbon content to meet 2017 Baja SAE Rules. The yield strength of 4130 steel is 436 MPa, and the modulus of elasticity is assumed to be the same as that of 1018 per the rule booklet. 4130 steel can also be purchased locally from Ipaco Inc. Chromalloy costs approximately \$4.50 per foot for 1.25 in. diameter, 0.625 in. thick tubing. Chromalloy is available within one week of order placement (acceptable per Goal 1.3.2), as quoted by Ipaco. Because 4130 is stronger, we can use a thinner cross-section, which allows weight savings of up to 28% compared to 1018 steel (see Appendix B).

The following decision matrix was created to compare the two steel concepts according to weight and cost. Manufacturability is not considered since there is no appreciable difference in fabrication difficulty or cost of supplies. The weight and cost for each concept are normalized against the heaviest and most expensive design. As before, weight is considered three times as important as cost. The resulting scores reflect that using a combination of 4130 steel for the primary members will be better than using 1018 steel for this application.

Table 3. Decision Matrix for Tubing Selection

		Concepts	
Requirements	Weight	1018	4130
1.2.1.1 (Weight)	3	0	0.25
1.2.2.1 (Cost)	1	0.67	0
Total Score:		0.67	0.75

Worst	Best

2.3.3 Firewall Selection

As explained in section 2.2.3, 2017 Baja SAE rules require a firewall thickness of at least 0.02 in. and metal composition. As shown in Table 1, Aluminum 5052 is the cheapest and lightest material that meets both of the 2017 Baja SAE requirements.

3 SYSTEM OVERVIEW

As defined by the customer, the Mini Baja has been divided into three separate design groups: frame, suspension, and drivetrain. Here, an overview of the frame system design decisions that have been made at this point. The frame system has been divided into four subsystems: frame structure, integration (with the suspension and drivetrain systems), safety, and controls.

The frame will be constructed of 1.25 in. OD, 0.065 in. WT, normalized 4130 Chromalloy steel for primary members, and 1 in. OD, 0.030 in. WT, 1018 steel for secondary members. The frame will have various mounting tabs, brackets, and supports in order to integrate the suspension, steering, braking, drivetrain, and safety systems. The frame will be MIG welded by team members who pass the 2017 Baja SAE Rules welding tests. More detail on these topics can be found in sections 4 and 5 of this document.

The majority of safety items are mandated and specified by the 2017 Baja SAE rules. Those items will be purchased, installed, and used according to those regulations. Safety is addressed in section 6 of this document. Safety will be encouraged by the production of a custom, in-house carbon fiber seat padded with high-density foam. The seat will enhance driver stability and use of vehicle controls. Controls will be purchased or made according to the descriptions found in section 7.

4 FRAME STRUCTURE SUBSYSTEM

The primary structure of the frame is constructed of two types of steel tubing; primary (structural) members consist of 4130 Chromalloy steel with 1.25 in. OD and 0.065 in. wall thickness, while secondary members consist of 1018 mild steel with 1.00 in. OD and 0.035 in. wall thickness, per Requirement 1.2.1. For a detailed analysis of the strength of primary members, see Appendix B. Approximately 60 ft. of primary members and 60 ft. of secondary members are necessary to achieve the structural and functional needs of the frame (Requirements 1.2.1 and 1.2.2). This amounts to a total weight of 65 lbs. for the skeletal frame. For more details, see Appendix A: Drawing Package.

5 INTEGRATION SUBSYSTEM

5.1 DRIVETRAIN MOUNTING

The engine and gearbox mounts attach to the horizontal frame members that extend rearward from the bottom of the rear roll hoop. With the center-to-center width of these members set at 10 in., the drivetrain team designs mounts for the engine and gearbox that attach to the frame. Our team assisted in welding the drivetrain team's mounts to the frame.

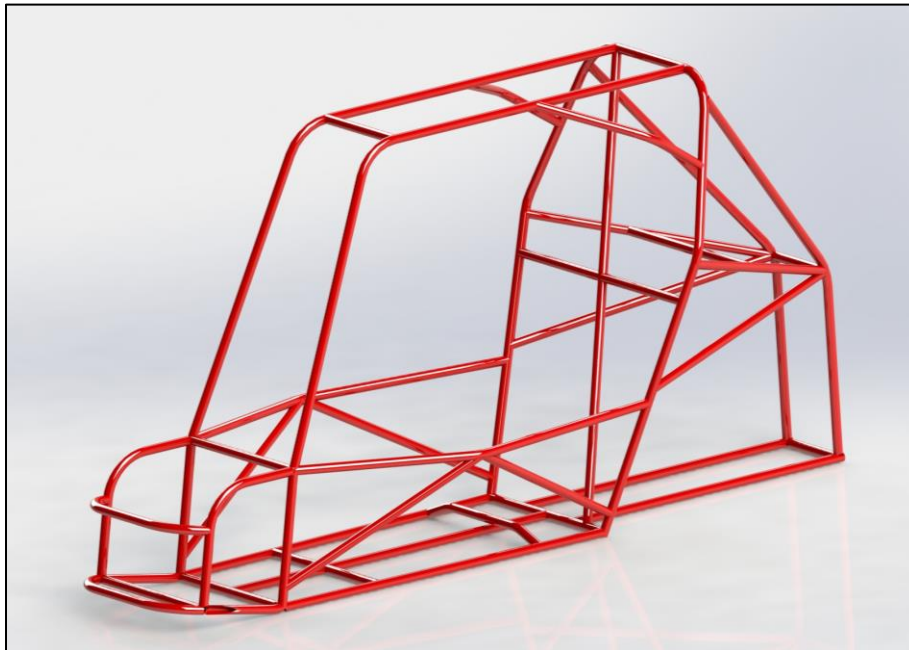

Figure 6. Frame rendering. Primary members (4130-n steel, 1.25" OD, 0.065" WT) are shown in red. No secondary members were used in this design.

5.2 SUSPENSION MOUNTING

The front and rear suspension mounts can attach to any of the existing frame members. Using the SolidWorks model of the frame, the suspension team designs mounts that provide correct suspension geometry that works with the frame model. The suspension team provides all fabrication and welding for the suspension mounts.

6 SAFETY SUBSYSTEM

The 2017 Baja SAE Rules states design requirements, beyond the construction of the frame, that ensures the safety of the Mini Baja vehicle driver. These requirements include multiple components: a metal firewall between the cockpit and the engine and fuel tank compartment, body panels that cover the area between the lower frame side member and the side impact members to prevent debris intrusion into the driver compartment, a belly pan, leg and foot shielding, a fire extinguisher with a UL rating of at least 5 B-C (Figure 7) with a Drake fire extinguisher mount (Figure 8), a kill-switch mounted inside the cockpit and another kill-switch mounted externally (Figure 9), five-point safety harness with 3 in. wide belts and a metal-to-metal quick release lever type buckle, arm restraints, and a seat with four mounting points on the bottom and two mounting points on the back.

The bucket-seat will be manufactured in-house. It will be constructed of pre-impregnated carbon fiber (Figure 10). To increase driver stability and comfort, 3 in. thick Lux foam as shown in Figure 11 will line the interior of the seat. The seat will be mounted to the frame using secondary member supports (1 in. OD, .035 in. thick 1018 tube steel) and 0.125 in. thick tabs.



Figure 7. 5 lb. Fire Extinguisher



Figure 8. Drake Figure Extinguisher Mount



Figure 9. Kill Switch



Figure 10. Driver Seat

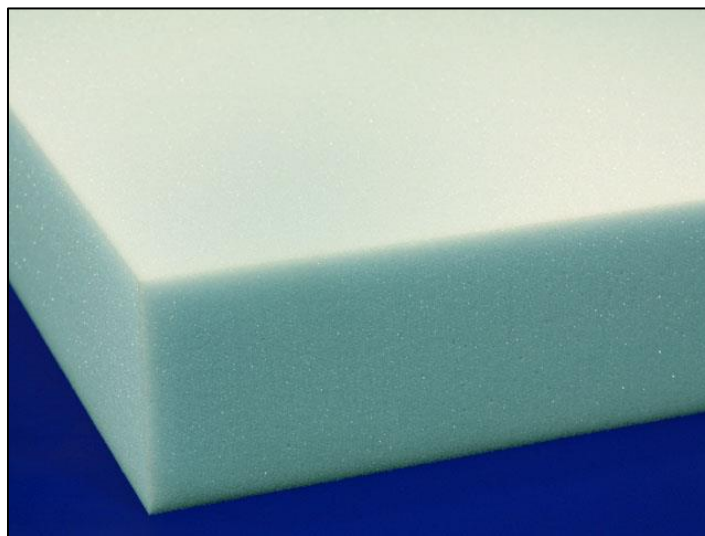

Figure 11. Foam for Seat

7 CONTROLS SUBSYSTEM

7.1 THROTTLE AND BRAKE PEDALS

The brake and throttle pedals will use a swing type pedal design. The pedals will be hinged above the foot rather than the floor. A dual master cylinder mounted forward of the termination point of the roll hoop will be used to control the front and rear brake.

A brake pedal with a 7:1 depression ratio will be used. The 7:1 ratio multiplies the driver input force by a factor of 7. The pedal shown in Figure 12 is the one specified to be used in our design. The brake pedal will be mounted on the left side of the steering column with a clearance of 2 in. This allows ample room for maneuverability of the driver's feet during competition.

The throttle pedal will be assembled in a similar way except on the right side of the steering column. The throttle pedal will be identical to the brake pedal, but with slight modification made to accommodate a throttle cable. The modification will be to attach the throttle cable through a 3/16" hole in the shaft of the pedal. The hole will be drilled 3" below the pivot point to achieve full throttle engagement. A clearance of 2 in. will be given between the throttle pedal and the steering column to give similar maneuverability. Having each pedal with a clearance of 2 in. gives a total distance between the pedals of about 4 in. This allows for comfortable operation of the Baja while preventing confusion between the pedals.



Figure 12. Wilwood Brake Pedal

7.2 STEERING COLUMN

The steering elements designed and specified by the Suspension and Steering team end at the input shaft of the rack and pinion mechanism shown in Figure 13. This input shaft features a 0.625 in. 36-spline connection, which we will connect to a universal joint for flexibility in the angle of the steering column.



Figure 13. Rack and Pinion with 5/8" 36-Spline Male Input

The universal joint will have a 0.625 in. 36-spline female connection (with set screw) at one end, to match the rack and pinion. At the other end, it will have a 0.75 in. ID weld-on female connection (Figure 14). This will be welded to a 0.75 in. OD, 1018 steel, steering shaft with a length of 24 in. The steering shaft will be supported by a 0.75 in. ID steering support bearing mounted using two 0.3125 in. bolts to a plate that is supported by secondary members (Figure 15). A 3 in. diameter, 1018 steel, round flange will be welded to the driver end of the steering shaft. This flange will serve as a connection point to an 11.5 in. steering wheel, which features 0.25 in. holes in a triangular bolt pattern with a side length of 1.4375 in. as defined by the steering wheel manufacturer (Figure 16).



Figure 14. Universal Joint for Steering System



Figure 15. Steering Shaft Support Bearing



Figure 16. Steering Wheel with Triangular Bolt Pattern

8 MANUFACTURING PLAN

Most of the manufacturing process will be focused on constructing the frame structure. The frame will be welded using the GMAW (MIG) method. The tubes will be coped to fit one another and reduce the gap to be filled by the welder. Copes will be made with a coping jig. We will use a flapper wheel to condition the surface before welding. All tube bends will be made by a bending machine.

Aside from prefabricated subassemblies, all machined parts will be created by students in the Utah State University Student Prototyping Lab. This includes drilling holes for bolts, tapping threads, and welding.

The carbon fiber bucket seat will be created by forming a sheet of mild steel to the shape described in the Safety subsystem design. On the outside of this mold, we will lay up 8 layers of pre-impregnated carbon fiber with 6 holes to accommodate fasteners. After curing, we will separate the carbon fiber from the mold and perform post-processing to remove irregularities and sharp edges.

Benchtop versions of the drivetrain and suspension components will be verified against the frame structure to ensure the fitment is correct. Then, we will weld the attachment points described in the Integration subsystem design.

9 SPECIAL TOPICS

9.1 SAFETY

We have based the majority of our research on providing the driver of the Mini Baja with a safe experience. There are many safety risks involved when driving a powered vehicle, the most prominent of these being a rollover accident. The safety of the driver during such an occasion will greatly depend on the structural soundness of our frame, and the security of safety restraints installed on the vehicle. We will confront these key issues by taking care with the fabrication of the body and attachment of the safety devices. Safety has been considered in more detailed in section 6 of this document.

9.2 BILL OF MATERIAL (BOM) OVERVIEW AND BUDGET

Table 4 lists the parts that we anticipate using for the prototype. This table will be subject to change during the subsystem analysis and manufacturing phases.

Based on the extent of the research we have performed during the early design phases, we have generated the above table of materials with their respective prices. Not included are the costs of tools, welding supplies, and repurchases due to mistakes. Total cost is estimated in the subsystem budget below (Table 5). This budget is a flexible guideline to assist in cost analysis and management of spending.

MINI BAJA – FRAME TEAM

Revision: 6
Effective Date: 05/05/2017

Page 25 of 28

Table 4. Bill of Materials

Subsystem	Description	Quantity	Cost	Subsystem Total
Frame Structure	Pipe, 4130-n, 1.25" OD, 0.065" WT, 20' Length	5	\$450.00	\$600.00
	Pipe, 4130-n, 1.0" OD, 0.035" WT, 20' Length	5	\$150.00	
Safety	Carbon Fiber Bucket Seat	1	\$ -	\$1,360.55
	Lux Foam, 84" x 24" x 2" Thick	1	\$21.99	
	Vinyl Fabric, Black, 2 Yards	1	\$9.99	
	Kill Switch	2	\$48.00	
	Brake Light	1	\$31.99	
	Reverse Light	1	\$20.00	
	Transponder	2	\$103.74	
	Brake Light Pressure Switch Assembly	2	\$29.98	
	Aluminum Plate, 0.25" x 3' x 6'	2	\$77.04	
	Five-Point Safety Harness	1	\$129.00	
	Motocross Helmet	2	\$300.00	
	Goggles with Tear-Offs	2	\$100.00	
	Gloves	2	\$90.00	
	Neck Brace	2	\$80.00	
	Fire-Retardant Jacket	2	\$128.16	
	Fire Extinguisher, 5 BC	2	\$120.66	
Arm Restraints (Pair)	2	\$70.00		
Controls	Brake Pedal Assembly	1	\$130.00	\$399.44
	Gas Pedal Assembly	1	\$130.00	
	Throttle Cable, Standard, 6'	1	\$18.99	
	Universal Joint, 5/8" 36-Spline to 3/4" Weld-On	1	\$69.97	
	Steering Shaft, 1018, 3/4" OD, 2' Length	1	\$12.99	
	Steering Support Bearing, 3/4" OD, Flanged	1	\$12.99	
	Go-Kart Steering Wheel, 11.5" OD	1	\$24.50	
Integration	C-Channel, 1/8" Thick x 1.25" Wide x 0.5" Tall x 3' Long	1	\$10.00	\$111.52
	Sheet, 1018, 12" x 18" x 1/4" Thick	1	\$101.52	
Miscellaneous	SAE Grade 8 Bolt, 1/4"-20, 1/2" Length, Full Thread	100	\$8.03	\$58.26
	SAE Grade 8 Nut, 1/4"-20, 7/16" Width, 7/32" Height	100	\$4.40	
	SAE Grade 8 Bolt, 3/8"-16, 1/2" Length, Full Thread	100	\$16.02	
	SAE Grade 8 Nut, 3/8"-16, 9/16" Width, 21/64" Height	100	\$7.84	
	Plastic Paneling, 1/16" x 4' x 8'	2	\$21.97	
Grand Total:				\$2,529.77

Table 5. Subsystem Budgets

	Category	Allotted Budget
Structure	Frame Structure	\$1,800.00
Controls	Throttle, Brake, and Steering Controls	\$600.00
Safety	Restraints and Driver Safety Equipment	\$1,400.00
	Body Paneling and Firewall	\$700.00
	Electronics	\$500.00
	Total:	\$5,000.00

9.3 LESSONS LEARNED

Through this design process, we have discovered several important lessons that would have improved our workflow. First, it is important to maintain proactive communication with other design teams. Bad design paths could have been recognized earlier through open communication with experts on other systems. It is also necessary to set hard deadlines for expectations of others within and between teams. Failure to set and adhere to deadlines slowed down the design process, leading to wasted effort and time.

Also, having defined roles for team members is imperative to achieve design milestones. Often, taking on too many unique roles prevented us from focusing on important decisions. If each team member knows his or her role, less time is spent delegating responsibility on a case by case basis.

In the planning phase of the design, it is critical to set achievable and verifiable objectives. Our system requirements among all teams were heavily influenced by design decisions that had already been made based on initial assumptions. In all requirements and design decisions, conserving weight should be a top priority.

Further, in the early stages of the design, we failed to prioritize the most important decisions. It would have helped to focus on decisions with the broadest consequences. We wasted time making multiple conflicting judgments and failing to adequately justify those judgments.

The manufacturing process taught us the importance of having a complete model of the entire vehicle before beginning manufacturing. The complete model should include all tabs and mounts for every component. A complete model would also include all components from the other USU Mini Baja teams.

By attending the competition, we learned the importance of passing technical inspection early. To pass tech inspection early, teams should ensure all 2017 SAE Baja rules have been met prior to leaving for competition, and teams should arrive as early as possible to the competition to obtain a good parking spot.

9.4 RECOMMENDED FUTURE WORK

Success in the SAE Mini Baja competition lies in improving upon the engineering of the team before. Because Utah State University has not participated in the SAE Mini Baja Competition in seven years, it was difficult to understand what successes or failures were had in the last competition. Going forward, it would be very beneficial to future teams to focus on this year's ups and downs.

For future USU Mini Baja teams, we recommend testing the current Mini Baja on terrain that is likely to be found in the next competition. Using the results of these tests, a new Mini Baja will be able to designed and built in a way that is optimal for the situations it will encounter. Additionally, further research into ways to save weight is encouraged. With all of the competition using the exact same engine, saving weight is the number one advantage that can be gained over other teams.

Besides weight, advantage can be gained by driver skills. While that may be obvious, in practice it is difficult to get time in the seat of the Mini Baja because of the Logan winter and how late into the spring it usually lasts. It is recommended that future USU teams get practice in past Mini Baja vehicles in the fall before there is snow on the ground.

After participating in the competition, we have identified key improvements that can be made for future iterations of this vehicle. These recommendations are for the vehicle as a whole and not exclusive to the frame design space.

Above all, overall weight should be drastically reduced from the old vehicle to improve the competitiveness in future years. We recommend a reduction of at least 75 pounds. Some key areas to examine would be the heavy usage of oversized OEM parts, specifically the wheel hubs, brake calipers and CVT cover. This would improve the acceleration, top speed, hill climbing ability and handling characteristics of the vehicle.

One major shortcoming of this year's design was the large turning radius. This was detrimental to our performance in the maneuverability and suspension dynamic events. We recommend reducing the turning radius by more than 25 percent. This could be done by shortening the frame length and reducing the understeer. We estimate reducing the frame length by 10 inches would greatly improve these characteristics. Improvement in this area would have a large impact on our overall placement by improving our scores in both the suspension and maneuverability events drastically.

Increasing the ride height would improve performance in all events, specifically the suspension and endurance events. The suspension travel was adequate, we just didn't have enough ground clearance to clear all the obstacles on the course. In the endurance event, we had a major repair on the lower front A-arm to repair damage caused by hitting a large rock. This took over an hour, causing us to lose time in the event. Also, ride height would improve the performance over the rock obstacles. We recommend the ride height be 16 to 18 inches in the front and 14 to 16 inches in the rear. This gives us more clearance over obstacles, reducing our risk of damage to the vehicle.

Another key area that should be focused on is vehicle testing. We recommend that future teams complete at least 10 hours of testing on the previous design as well as at least 10 hours of hard

endurance testing on the new design. While doing this testing, we recommend fine tuning the CVT. In order to achieve the optimum CVT performance, future teams will need to purchase more variations of CVT springs and weights. One of our issues was that we did not have enough time to fully understand and examine our CVT tuning.

Lastly, we recommend minimizing the amount of driver change involved in dynamic events. This could also be done through testing, extensive time trials, and driver skill analysis. Drivers should be determined before going to the competition and these decisions should be final.

Appendix A

Drawing Package

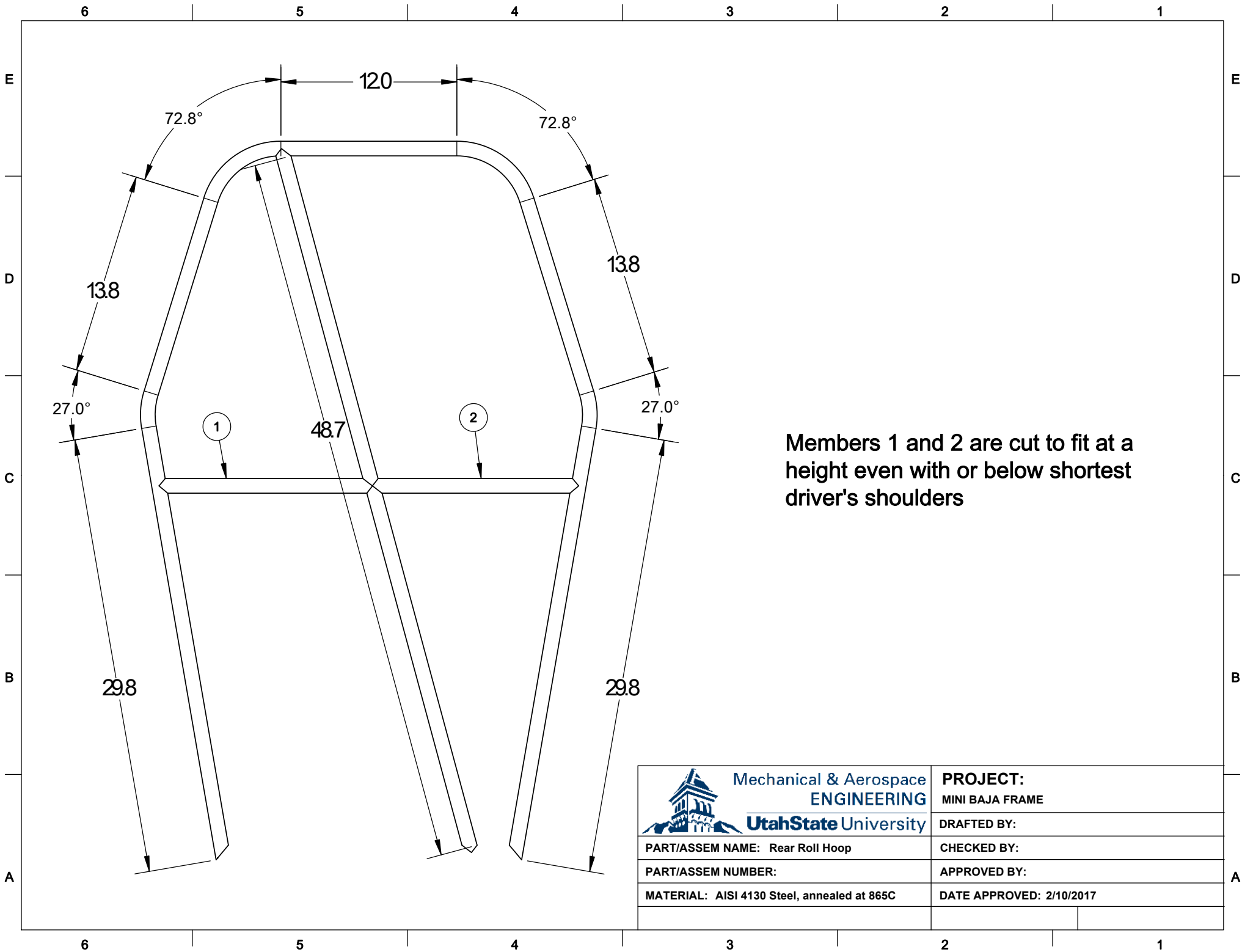

Members 1 and 2 are cut to fit at a height even with or below shortest driver's shoulders

 Mechanical & Aerospace ENGINEERING UtahState University	PROJECT: MINI BAJA FRAME
	DRAFTED BY:
PART/ASSEM NAME: Rear Roll Hoop	CHECKED BY:
PART/ASSEM NUMBER:	APPROVED BY:
MATERIAL: AISI 4130 Steel, annealed at 865C	DATE APPROVED: 2/10/2017

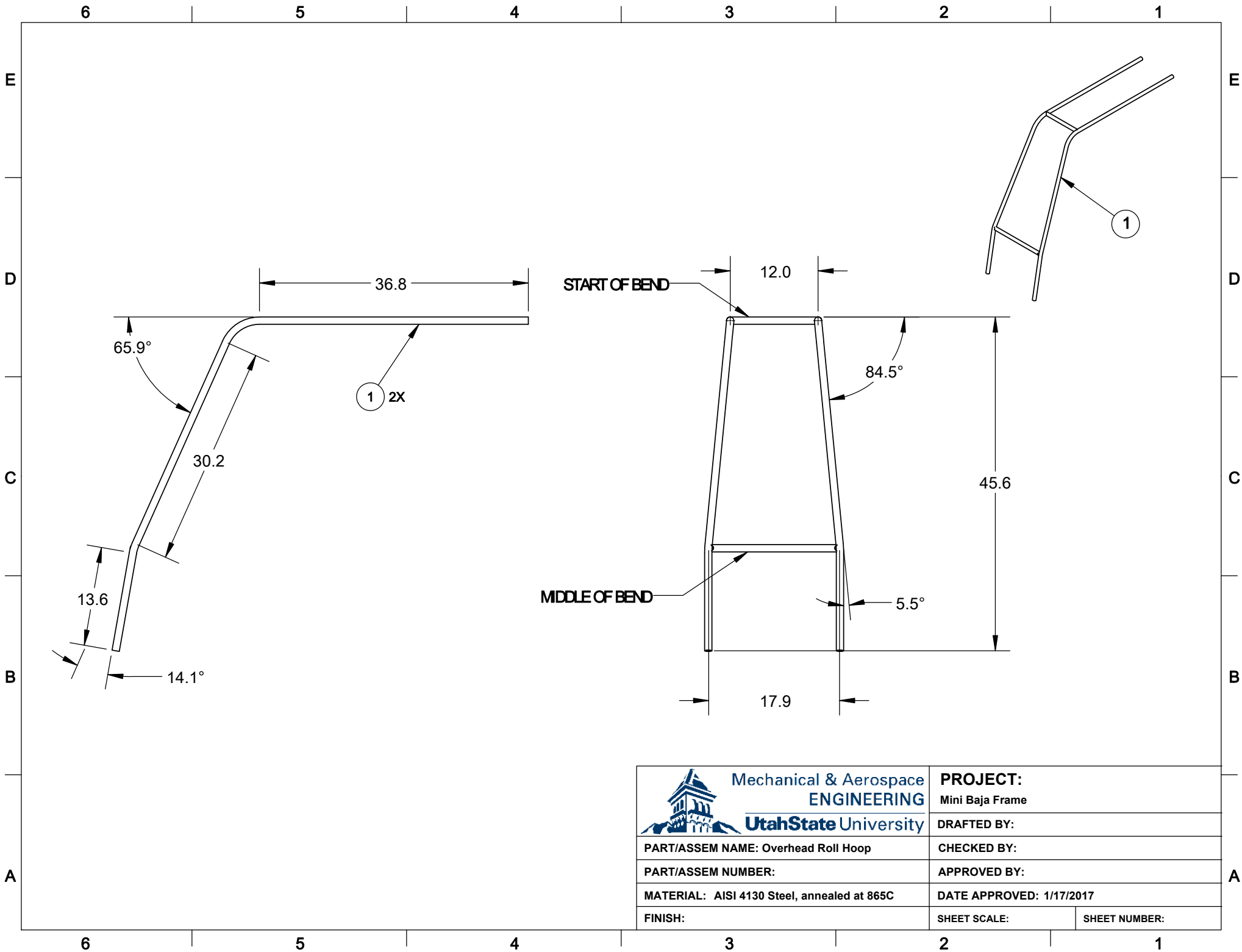

 Mechanical & Aerospace ENGINEERING UtahState University	PROJECT: Mini Baja Frame	
	DRAFTED BY:	
PART/ASSEM NAME: Overhead Roll Hoop	CHECKED BY:	
PART/ASSEM NUMBER:	APPROVED BY:	
MATERIAL: AISI 4130 Steel, annealed at 865C	DATE APPROVED: 1/17/2017	
FINISH:	SHEET SCALE:	SHEET NUMBER:

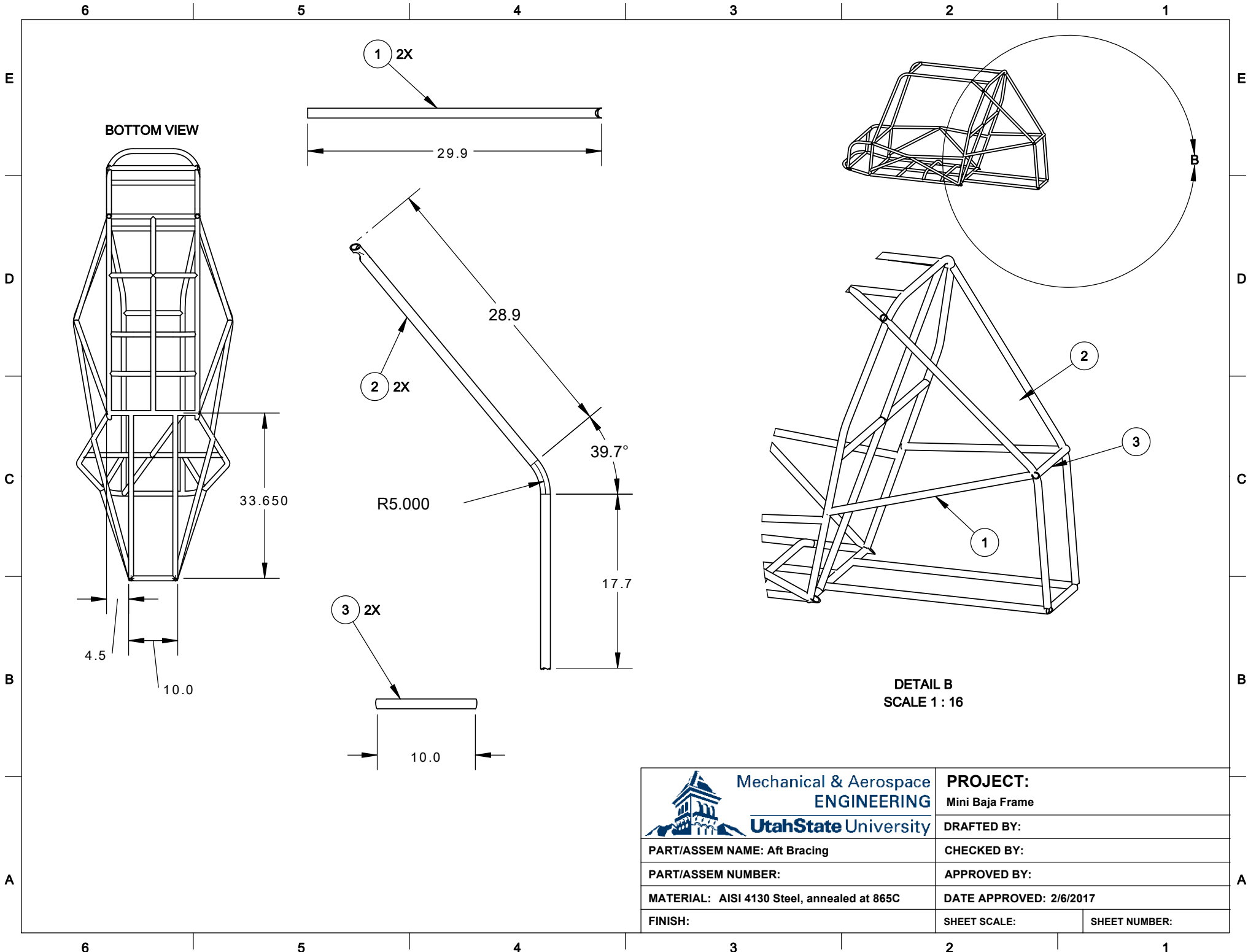

BOTTOM VIEW

33.650

29.9

28.9

39.7°

17.7

R5.000

10.0

DETAIL B
SCALE 1 : 16

 Mechanical & Aerospace ENGINEERING UtahState University	PROJECT: Mini Baja Frame	
	DRAFTED BY:	
PART/ASSEM NAME: Aft Bracing	CHECKED BY:	
PART/ASSEM NUMBER:	APPROVED BY:	
MATERIAL: AISI 4130 Steel, annealed at 865C	DATE APPROVED: 2/6/2017	
FINISH:	SHEET SCALE:	SHEET NUMBER:

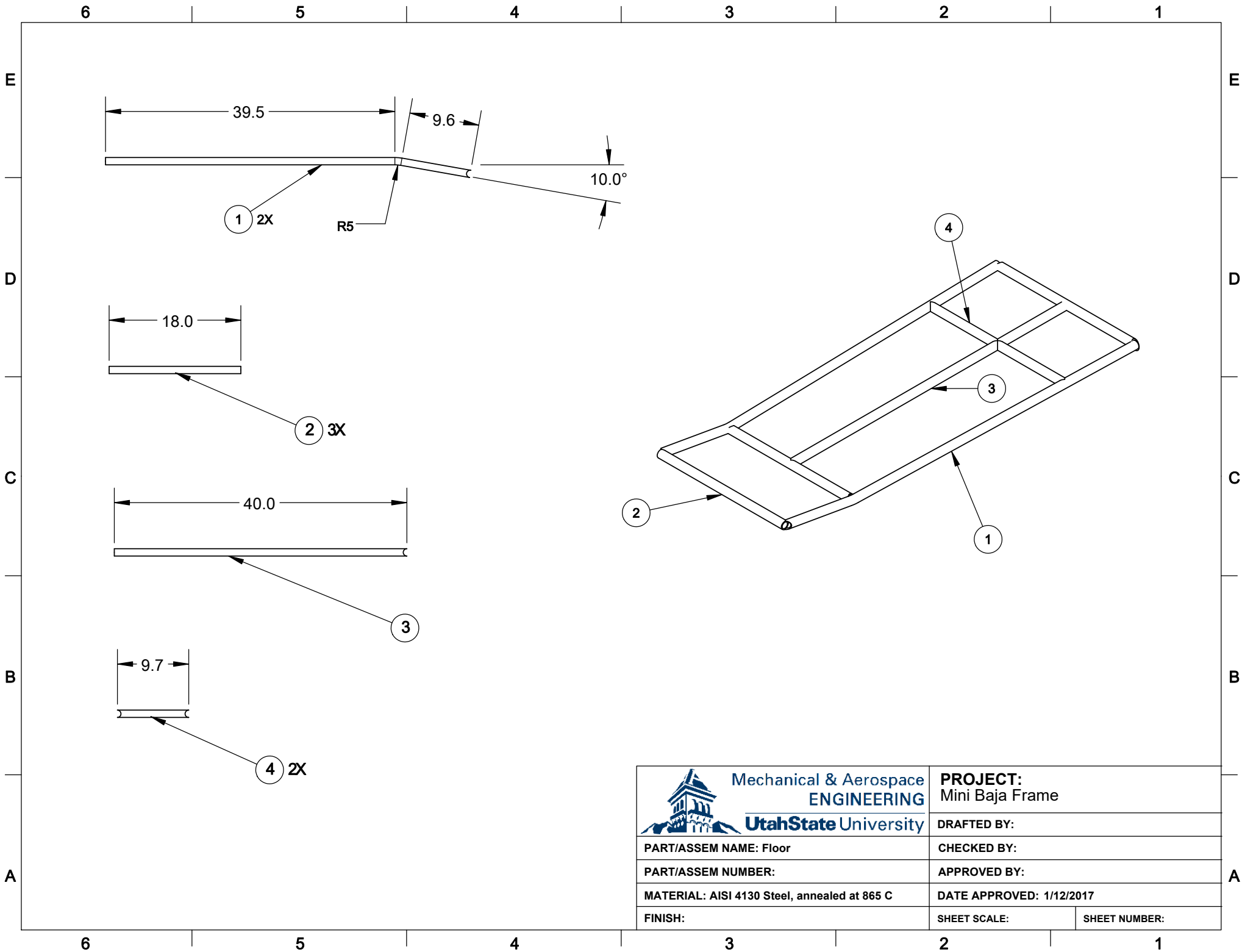

 Mechanical & Aerospace ENGINEERING Utah State University	PROJECT: Mini Baja Frame	
	DRAFTED BY:	
PART/ASSEM NAME: Floor	CHECKED BY:	
PART/ASSEM NUMBER:	APPROVED BY:	
MATERIAL: AISI 4130 Steel, annealed at 865 C	DATE APPROVED: 1/12/2017	
FINISH:	SHEET SCALE:	SHEET NUMBER:

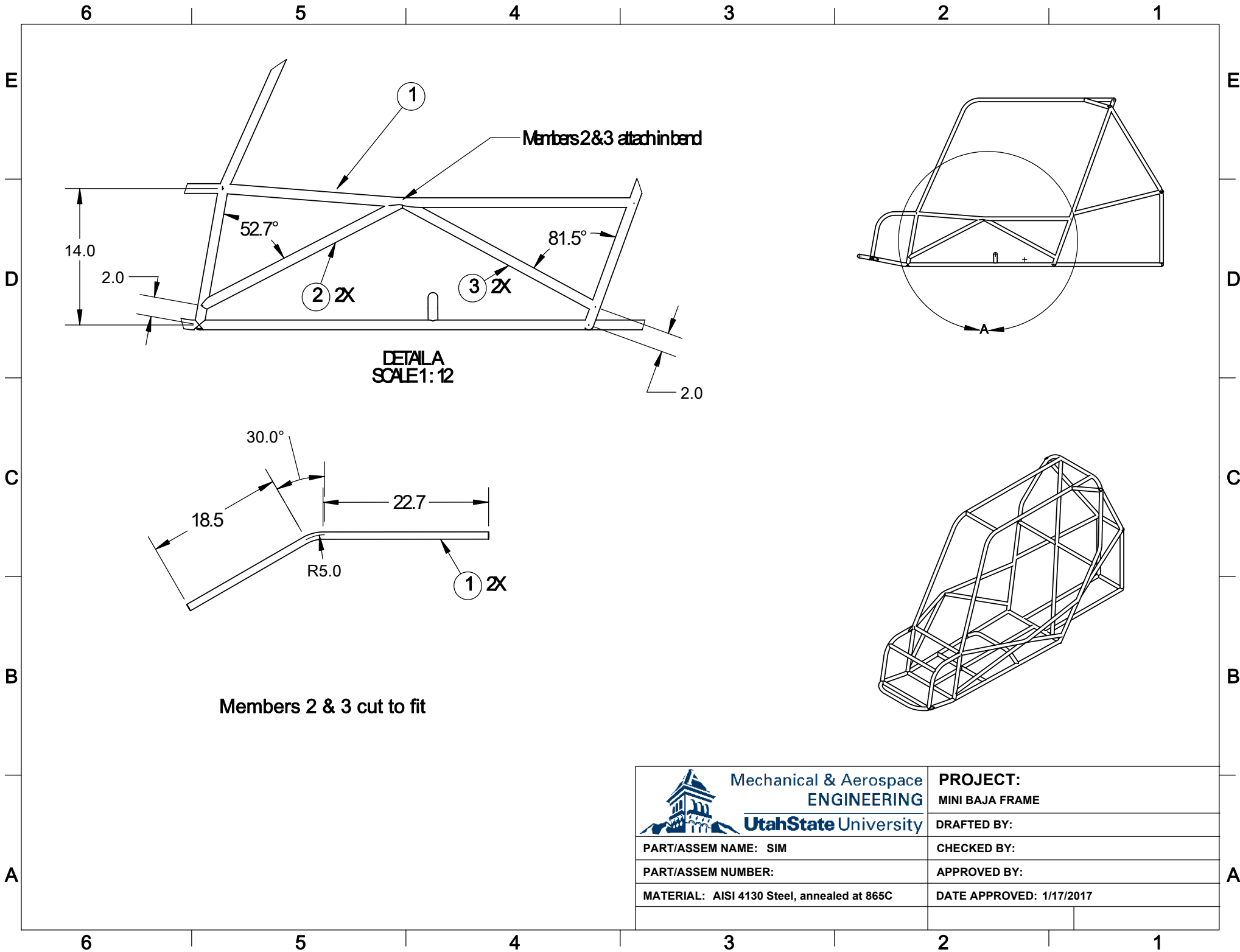

**Mechanical & Aerospace
ENGINEERING**
Utah State University

PROJECT:
MINI BAJA FRAME

DRAFTED BY:

PART/ASSEM NAME: SIM

CHECKED BY:

PART/ASSEM NUMBER:

APPROVED BY:

MATERIAL: AISI 4130 Steel, annealed at 865C

DATE APPROVED: 1/17/2017

A

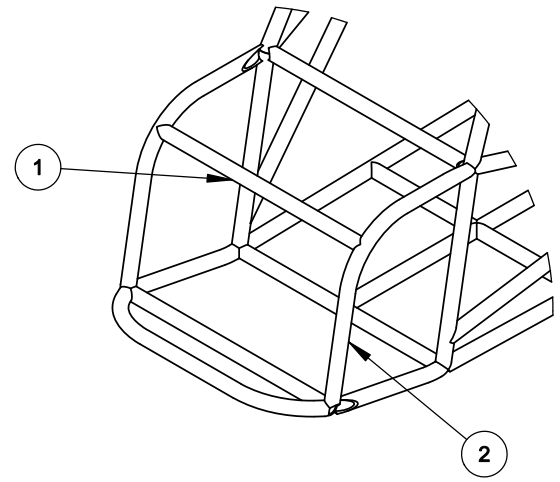
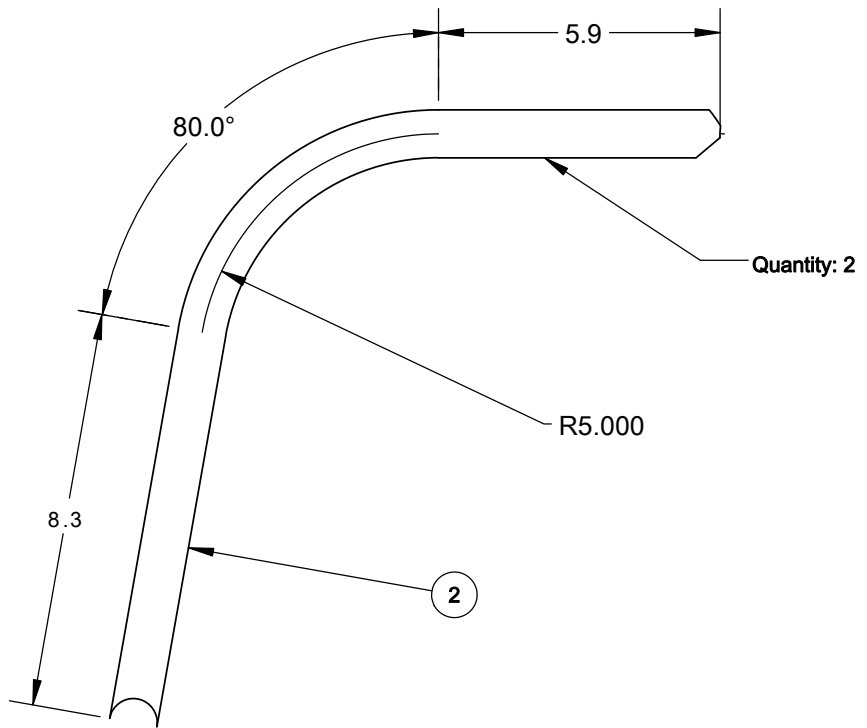
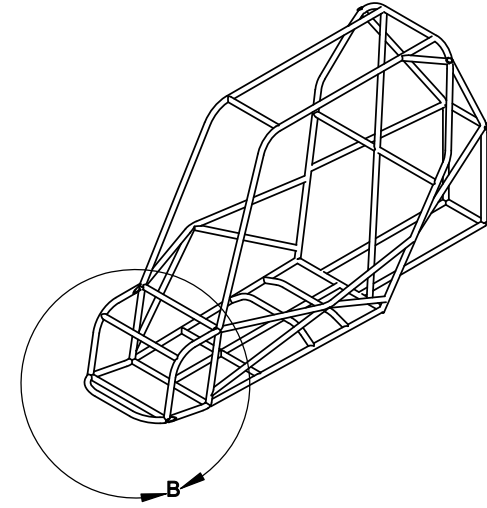
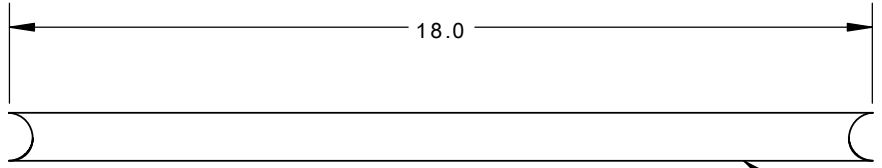

DETAIL B
SCALE 1 : 12

 Mechanical & Aerospace ENGINEERING UtahState University	PROJECT: Mini Baja Frame	
	DRAFTED BY:	
PART/ASSEM NAME: Nose	CHECKED BY:	
PART/ASSEM NUMBER:	APPROVED BY:	
MATERIAL: AISI 4130 Steel, annealed at 865C	DATE APPROVED: 1/25/2017	
FINISH:	SHEET SCALE:	SHEET NUMBER:

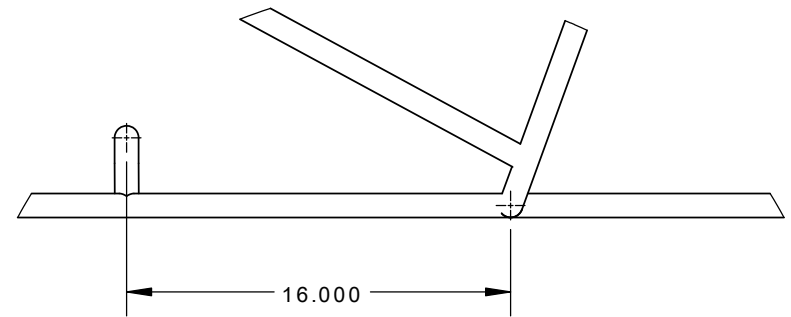
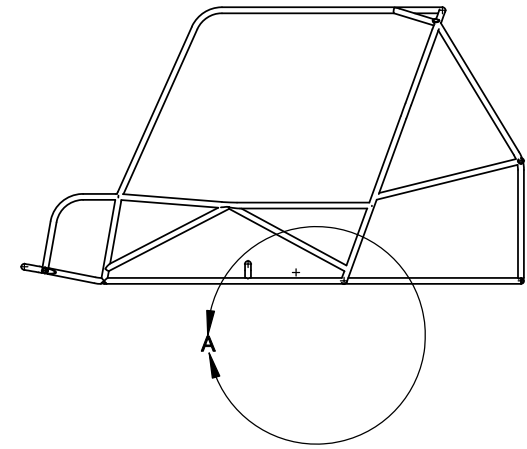
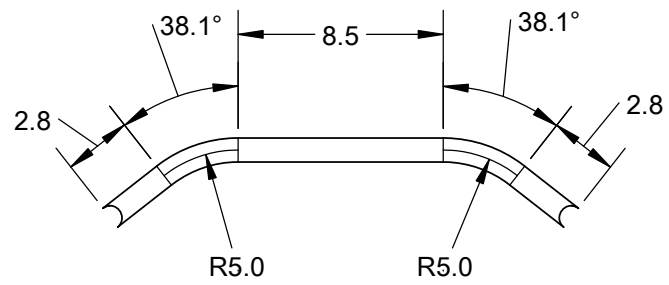

DETAIL A
SCALE 1 : 8

	Mechanical & Aerospace ENGINEERING	PROJECT: MINI BAJA FRAME
	Utah State University	DRAFTED BY:
PART/ASSEM NAME: Seat Support	CHECKED BY:	APPROVED BY:
PART/ASSEM NUMBER:	DATE APPROVED: 1/17/17	
MATERIAL: AISI 4130 Steel, annealed at 865C		

Appendix B

Equivalent Tube Strength / Stiffness Calculations

Baja SAE Roll Cage Equivalency Calculations

Minimum Tubing Geometry:

Diameter	$d_1 := 25.4 \text{ mm}$	(1in)
Wall Thickness	$t_1 := 3.05 \text{ mm}$	(0.120in)
Material	1018 Steel	

Material Properties - 1018 Steel:

Modulus of Elasticity	$E_1 := 205 \cdot 10^9 \text{ Pa}$
Yield Strength	$\sigma_{y1} := 365 \cdot 10^6 \text{ Pa}$

Specified Tubing Geometry:

Diameter	$d_2 := 31.75 \text{ mm}$	(1.25in)
Wall Thickness	$t_2 := 1.651 \text{ mm}$	(0.065in)
Material	4130 Steel	

Material Properties - 4130 Steel:

Modulus of Elasticity	$E_2 := 205 \cdot 10^9 \text{ Pa}$
Yield Strength	$\sigma_{y2} := 436 \cdot 10^6 \text{ Pa}$

Stiffness Verification:

Define pi for moment of inertia:

$$\pi := 4 \cdot \text{atan}(1) = 3.142$$

$$I_1 := \pi \cdot \frac{[d_1^4 - (d_1 - 2t_1)^4]}{64} = 1.362 \times 10^4 \text{ mm}^4 \quad (\text{required})$$

Moment of Inertia

$$I_2 := \pi \cdot \frac{[d_2^4 - (d_2 - 2t_2)^4]}{64} = 1.773 \times 10^4 \text{ mm}^4 \quad (\text{specified})$$

$$E_1 \cdot I_1 = 2.792 \times 10^{15} \text{ Pa} \cdot \text{mm}^4 \quad (\text{required})$$

Stiffness

$$E_2 \cdot I_2 = 3.635 \times 10^{15} \text{ Pa} \cdot \text{mm}^4 \quad (\text{specified})$$

Strength Verification:

$$\frac{(\sigma_{y1} \cdot 10^{-6} \cdot I_1)}{\left(\frac{d_1}{2}\right)} = 3.915 \times 10^5 \text{ N} \cdot \text{mm} \quad (\text{required})$$

Bending Strength

$$\frac{(\sigma_{y2} \cdot 10^{-6} \cdot I_2)}{\left(\frac{d_2}{2}\right)} = 4.87 \times 10^5 \text{ N} \cdot \text{mm} \quad (\text{specified})$$

Appendix C

2017 Baja SAE Rules



2017 Collegiate Design Series

Baja SAE[®] Rules

Table of Contents

PART A: ADMINISTRATIVE REGULATIONS	3
ARTICLE 1: BAJA SAE® OVERVIEW	3
ARTICLE 2: BAJA SAE® SERIES	3
ARTICLE 3: BAJA SAE® RULES AND ORGANIZER AUTHORITY	4
ARTICLE 4: INDIVIDUAL PARTICIPATION REQUIREMENTS.....	5
ARTICLE 5: FACULTY ADVISOR	6
ARTICLE 6: ELIGIBILITY – VEHICLES	6
ARTICLE 7: REGISTRATION	7
ARTICLE 8: RULES QUESTIONS	8
ARTICLE 9: PROTESTS/APPEALS	8
PART B: TECHNICAL REQUIRMENTS	9
ARTICLE 1: GENERAL DESIGN REQUIREMENTS	9
ARTICLE 2: REQUIRED ENGINE (NEW)	10
ARTICLE 3: ELECTRICAL SYSTEM	14
ARTICLE 4: TOWING HITCH POINT	16
ARTICLE 6: TRANSPONDERS	18
ARTICLE 8: ROLL CAGE.....	20
ARTICLE 9: COCKPIT AND THROTTLE.....	29
ARTICLE 10: DRIVER RESTRAINT AND SEATING.....	31
ARTICLE 11: BRAKING SYSTEM	38
ARTICLE 12: FUEL SYSTEM AND FUEL (UPDATED).....	38
ARTICLE 14: FASTENERS.....	42
ARTICLE 15: GUARDS (Updated)	Error! Bookmark not defined.
ARTICLE 16: DRIVER EQUIPMENT (Updated)	43
PART C: DYNAMIC EVENTS-STATIC EVENTS – (U.S & CANADIAN EVENTS)	45
ARTICLE 1: SCORING	45
ARTICLE 2: TECHNICAL INSPECTION	45
ARTICLE 3: ENGINEERING DESIGN EVENT	47
ARTICLE 4: COST EVENT.....	50
ARTICLE 5: SALES PRESENTATION EVENT – all competitions – 50 Points.....	52
PART D: DYNAMIC EVENTS- (U.S and Canadian Events) TOTAL – 700 POINTS	52
ARTICLE 1: ACCERLATION –75 Points	53
ARTICLE 2: HILL CLIMB or TRACTION EVENT- 75 POINTS.....	53
ARTICLE 3: MANEUVERABLIITY EVENT –75 points.....	54
ARTICLE 4: SPECIALTY EVENTS –75 points.....	55
ARTICLE 5: ENDURANCE – 400 Points.....	55
ARTICLE 6: COMPETITION PROCEDURES AND REGULATION – GENERAL.....	59
ARTICLE 7: PADDOCK RULES	60
ARTICLE 8: DRIVING RESTRICTIONS	61
ARTICLE 9: RULES OF CONDUCT	61
ARTICLE 10: SPECTATOR RULES.....	61
ARTICLE 11: MISCELLANEOUS.....	62
ARTICLE 12: SAFETY – TEAM RESPONSIBILITY	62
ARTICLE 13: VISA REQUESTS.....	62
PART E: DESIGN AND COST SUBMISSION PROCEDURES	63
ARTICLE 1: ONLINE SUBMISSIONS	63
ARTICLE 2: NOTICE OF “POSSIBLE” RULE CHANGES FOR 2018:.....	65
ARTICLE 3: APPENDIX S- SAE TECHNICAL STANDARDS	65

2017 Baja SAE® Rules
“Partial” List of Rule Updates/Changes

This introduction list to the 2017 Baja SAE® Rules is intended to highlight certain areas of the rules where a change/update or clarification has been made.

Caution! These are not the complete changes! Neither this list of updates/changes nor any summary is a substitute for thoroughly reading and understanding the rules. You are responsible for knowing and following all the Baja SAE® Rules. We cannot stress this enough.

Read the Rules thoroughly!

Please be sure to reference the Baja SAE® News Feed (<http://students.sae.org/cds/bajasae/news>) for all updates.

“Partial” list of new updates/changes

ARTICLE 2-Section B: REQUIRED ENGINE (NEW, IMPORTANT ENGINE INFORMATION)

A7.2 Team Registration and Engine Order Deadline: November 14, 2016

A7.3.1 Failure to Meet Deadlines (UPDATED/CHANGED)

SAE International will be placing this policy into effect that “**failure to submit the required Cost, Design or Technical documents within 5 days of the deadline will constitute an automatic withdrawal of your team.**” Your team will be notified by the 5th day of no submission that we have not received your documents and after 6 days your team’s registration will be cancelled and no refund will be given.

B6.2 Transponder Requirement updated

B8.3.1 Elements of the Roll Cage revised/updated

B8.7.3 Pre Frame Check Document Response Process: revised/updated

B9.10 Fire Extinguisher and Required Mount updated

B15.1 Powertrain Guards updated

PART A: ADMINISTRATIVE REGULATIONS

ARTICLE 1: BAJA SAE® OVERVIEW

The Baja SAE® competition series originated at the University of South Carolina in 1976, under the direction of Dr. John F. Stevens. Since that time, the Baja SAE® Series has grown to become a premier engineering design series for university teams.

A1.1 Baja SAE® Program Objective

Baja SAE® is an intercollegiate engineering design competition for undergraduate and graduate engineering students. The object of the competition is to simulate real-world engineering design projects and their related challenges. Each team is competing to have its design accepted for manufacture by a fictitious firm. The students must function as a team to design, **engineer**, build, test, promote and compete with a vehicle within the limits of the rules. They must also generate financial support for their project and manage their educational priorities.

A1.2 Design Subject

Each team's goal is to design and build a single-seat, all-terrain, sporting vehicle whose structure contains the driver. The vehicle is to be a prototype for a reliable, maintainable, ergonomic, and economic production vehicle which serves a recreational user market, sized at approximately 4000 units per year. The vehicle should aspire to market-leading performance in terms of speed, handling, ride, and ruggedness over rough terrain and off-road conditions. Performance will be measured by success in the dynamic events which are described in the Baja SAE® Rules, and are subject to event-site weather and course conditions.

A1.3 Good Engineering Practices

Vehicles entered into Baja SAE® competitions are expected to be designed and fabricated in accordance with good engineering practices.

ARTICLE 2: BAJA SAE® SERIES

A2.1 The Baja SAE® Series will consist of seven competitions. Three competitions are held in North America under the sponsorship of SAE International:

Baja SAE® Kansas	Hosted by Pittsburg State University
Baja SAE® California	
Baja SAE® Illinois	Hosted by the SAE Central Illinois Section

Baja SAE® competitions held in Africa, Asia, South America, and Mexico are associated with SAE International, but organized and sponsored by their local hosts:

Baja SAE® Brazil	– Sponsored and hosted by SAE BRASIL
Baja SAE® Korea	– Sponsored and hosted by Yeungnam University
Baja SAE® South Africa	– Sponsored by Sasol and hosted by the Gerotek Test Facilities
Baja SAE® Mexico	– Sponsored and hosted by SAE Mexico

A2.2 All Baja SAE® competitions have open registration policies and accept teams of university students from any country.

A2.2.1 Some sections of rules governing Baja SAE® events held outside North America are specific to these competitions. Such variations are published on the individual websites.

A2.2.2 The dynamic events at competitions differ. Teams should check the websites of the specific competitions they are planning to enter and consider any unique requirements that might affect the design and fabrication of their vehicle.

A2.3 Official Announcements and Competition Information

Teams are required to read the articles posted on the Baja SAE® news page (<http://students.sae.org/cds/bajasae/news>) published by SAE International and the other organizing bodies. Teams must also be familiar with all official announcements concerning the competitions and rule interpretations released by the Baja SAE® Rules Committee.

A2.4 Official Languages

The official language of the Baja SAE® Series is English. Document submissions, presentations and discussions in English are acceptable at all competitions in the series.

Team members, judges, and officials at non-U.S. competition events may use their respective national languages for document submissions, presentations and discussions if all the parties involved agree to the use of that language.

Baja SAE® Kansas	English
Baja SAE® California	English
Baja SAE® Illinois	English
Baja SAE® Brazil	English and Portuguese
Baja SAE® Korea	English and Korean
Baja SAE® South Africa	English and Spanish

ARTICLE 3: BAJA SAE® RULES AND ORGANIZER AUTHORITY

A3.1 Rules Authority

The Baja SAE® Rules are the responsibility of the Baja SAE® Rules Committee and are issued under the authority of the SAE International University Programs Committee. Official announcements from the Baja SAE® Rules Committee, SAE International or the other Baja SAE® Organizers shall be considered part of and have the same validity as these rules. Ambiguities or questions concerning the meaning or intent of these rules will be resolved by the Baja SAE® Rules Committee, National Techs, or SAE International Staff during competition onsite.

A3.2 Rules Validity

The Baja SAE® Rules posted on the SAE International website (www.sae.org) and dated for the calendar year of the competition are the rules in effect for the competition. Rule sets dated for other years are invalid.

A3.3 Rules Compliance

By entering a Baja SAE® competition, the team members, faculty advisors and other personnel of the entering university agree to comply with, and be bound by, the rules and all rules interpretations or procedures issued or announced by SAE International, the Baja SAE® Rules Committee and other organizing bodies. All team members, faculty advisors and other university representatives are required to cooperate with, and follow all instructions from competition organizers, officials and judges.

A3.4 Understanding the Rules

Teams are responsible for reading and understanding the rules in their entirety for the competition in which they are participating. The section and paragraph headings in these rules are provided to facilitate reading; they do not fully explain all the paragraph contents.

A3.4.1 Loopholes

It is virtually impossible for a set of rules to be so comprehensive that it covers all possible questions about the vehicle's design parameters or the conduct of the competition. Please keep in mind that safety remains paramount during Baja SAE®, so any perceived loopholes should be resolved in the direction of increased safety/concept of the competition.

A3.5 Participating in the Competition

Teams, team members as individuals, faculty advisors and other representatives of a registered university who are present on-site at a competition are considered to be "participating in the competition" from the time they arrive at the event site until they depart the site at the conclusion of the competition or earlier by withdrawing.

A3.6 Violations of Intent

The violations of the intent of a rule will be considered a violation of the rule itself. Questions about the intent or meaning of a rule may be addressed to the Baja SAE® rules committee, Technical Inspectors or SAE International staff.

A3.7 Right to Impound

SAE International and the other competition organizing bodies reserve the right to impound any on-site registered vehicle at any time during a competition for inspection and examination by the organizers, officials and technical inspectors.

A3.8 General Authority

SAE International and the competition organizing bodies reserve the right to revise the schedule of any competition and/or interpret or modify the competition rules at any time and in any manner that is, in their sole judgment, required for the efficient operation of the event or the Baja SAE® series as a whole.

A3.10 SAE International Technical Standards Access

A cooperative program of SAE International's Education Board and Technical Standards Board is making some of SAE International's Technical Standards available to teams registered for any North American Collegiate Design Series (CDS) competition at no cost. The Technical Standards referenced in the CDS rules, along with other standards with reference value, will be accessible online to registered teams, team members and faculty advisors.

To access the standards (1) your team must be registered for a competition in North America and (2) the individual team member or faculty advisor wanting access must be affiliated to the team on SAE International's website (www.sae.org).

Access Procedure - Once your team has registered, there will be a link to the SAE MOBILUS to access the technical standards under "Design Standards" on your profile page where all the required onsite team information is added. On the SAE MOBILUS, you will have the ability to search standards either by J-number assigned or topic of interest such as brake light.

A list of accessible SAE Technical Standards can be found in Appendix S.

ARTICLE 4: INDIVIDUAL PARTICIPATION REQUIREMENTS

A4.1 Eligibility Limits

Eligibility is limited to undergraduate and graduate students to ensure this is an engineering competition rather than a race. Individual members of teams participating in this competition must satisfy the following requirements:

A4.2 Student Status

Team members must be enrolled as degree seeking undergraduate or graduate student in a college or university. Team members who have graduated during the last seven (7) month period prior to the competition remain eligible to participate.

A4.3 Society Membership

Team members must be members of at least one of the following societies: (1) SAE International or an SAE International affiliate society, (2) ATA, or (3) IMechE or (4) VDI. Proof of membership, such as a membership card, is required at the event.

Students who are members of one of the societies listed above are not required to join any of the other societies in order to participate in any SAE International competition, but they must have a Customer Account on SAE.org. For more information, reference <http://students.sae.org/cds/bajasae/resources/>. Those interested may join SAE International at: <http://www.sae.org/membership/join>.

A4.4 Age

Team members must be at least eighteen (18) years of age at the time of the competition.

A4.5 Driver's License

Team members who will drive a competition vehicle at any time during a competition must hold a valid, government issued driver's license. This will be required onsite for proof.

A4.6 Liability Waiver

All on-site participants and faculty are **required** to sign a liability waiver prior to or upon registering on-site.

A4.7 Insurance

Individual medical and accident insurance coverage is **required** and is the sole responsibility of the participant.

A4.8 Individual Registration Requirements – ACTION REQUIRED

A4.8.1 All participating team members and faculty advisors must be sure that they are individually affiliated to their respective school/university on the SAE International website (www.sae.org) through their team's profile page for each event they are participating in.

- A4.8.2** If you are not an SAE International member, go to <http://www.sae.org/membership/join> and click Join SAE for Students. Please note all student participants must be SAE International members to participate in the events; this is not mandatory for faculty advisors. Faculty members who wish to become SAE International members should choose an option under the “Professional Membership” link.
- A4.8.3** All unaffiliated faculty advisors, who are not SAE International members, are required to sign up for an [SAE International Customer Account](#) using their email address. Contact collegiatecompetitions@sae.org and provide the Customer Number received and the university name to be correctly affiliated to the university.
- A4.8.4** All student participants and faculty advisors must affiliate themselves to the appropriate team(s) online. To affiliate, refer to <http://students.sae.org/cds/bajasae/resources/>.
- A4.8.5** **Once you have associated yourself to your respective university team(s), all affiliated students and faculty must complete all requested information (i.e. Emergency Contact Information) on the team registration page.** All students must affiliate prior to the competition.

ARTICLE 5: FACULTY ADVISOR

A5.1 Faculty Advisor Status

Each team is expected and encouraged to have a Faculty Advisor appointed by the university. The faculty advisor is expected to accompany the team to the competition and will be considered by competition officials to be the official university representative.

A5.2 Responsibilities

Faculty Advisors are expected to advise their teams on general engineering and engineering project management theory.

A5.3 Limitations

Faculty advisors may not design any part of the vehicle nor directly participate in the development of any documentation or presentation.

Faculty Advisors may neither fabricate nor assemble any components nor assist in the preparation, maintenance, testing or operation of the vehicle.

Faculty Advisors are not allowed to participate during technical inspection, cost audit or design presentations. The team captain or other designated members of the team must do all the presenting although Faculty Advisors may silently observe.

Faculty Advisors may not design, build or repair any part of the vehicle.

ARTICLE 6: ELIGIBILITY – VEHICLES

A6.1 Student Created

The vehicle and associated documentation must be conceived, designed, **manufactured** and fabricated by the team members without direct involvement from professional engineers, faculty or professionals in the off-road and racing communities.

6.2 Kit Vehicles – Prohibited

Vehicles fabricated from a kit or published designs are ineligible to compete. Vehicles which have been professionally fabricated may be disqualified from the competition. Vehicles which have been professionally fabricated will be disqualified from the competition or receive a penalty. If a team does not have access to machine shop facilities, the frame can be professionally fabricated without a penalty attached. Lack of access must be documented (letter from the faculty advisor, copy of policies which prohibit machine shop access, etc.).

Any outsourcing must be reflected in cost reporting, with supporting receipts or invoices from your outsourced vendor.

A6.3 Prefabricated Subassemblies

These rules do not exclude the use of prefabricated or modified sub-assemblies.

ARTICLE 7: REGISTRATION

A7.1 Registration- North American competition registration for Baja SAE® events held in North America must be completed online. Online registration must be done by either (a) an SAE International member or (b) the official faculty advisor connected with the university and recorded as such in the SAE International database.

A7.2 **Entries per University**-Registration for Baja SAE® competitions held in North America has maximum of (2) vehicles per university depending on available space **to begin at 10:00 am EDT on Tuesday, October 4th.**

For the first two (2) weeks of online registration, universities will only be able to register one (1) vehicle per university, per competition in the North American Baja SAE® competition series.

Team registration and engine order deadline: November 14, 2016

A7.3 Registration Limit and Wait List

- Baja SAE Kansas is limited to 100 vehicles. (Plus 40 waitlist teams)
- Baja SAE California is limited to 100 vehicles. (Plus 40 waitlist teams)
- Baja SAE Illinois is limited to 100 vehicles (Plus 40 waitlist teams)

When any of the Baja SAE Events (North American events) have reached their maximum team limit, there will be 40 waitlisted spots available for teams to sign up. The waitlist will remain open until all 40 spots are filled or the registration deadline of November 14, 2016 is reached. For more information on the Wait List, refer to <http://students.sae.org/cds/bajasae/resources/>.

A7.3.1 Failure to Meet Deadlines (NEW/UPDATED)

All teams, both Registered and Waitlisted, for any Baja SAE® competition are required to submit all required documents prior to the competition.

(a) As evidence their car complies with the frame rules and to support the technical inspection process and (b) to provide material that the Cost and Design event judges need to evaluate the team during the competition. When these documents are not submitted our judges cannot properly assess the vehicle or the team.

Additionally, teams that do not submit Cost, Design, or Technical documents typically do not come to the competition. Teams that do not notify us that they are withdrawing create the following problems (1) they are included in the static event schedules and judging time is wasted and (2) their unused registration slot cannot be offered to a team on the waitlist. Additionally, failure to submit the required Cost, Design, and Technical Documents is a clear violation of the rules.

- **Therefore, SAE International will be placing the policy into effect that failure to submit the required Cost, Design or Technical documents within 5 days of the deadline will constitute an automatic withdrawal of your team.** Your team will be notified by the 5th day of no submission that we have not received your documents and after 6 days your team's registration will be cancelled and no refund will be given.

A7.4 Registration Dates

Teams must register for each Baja SAE® competition they intend to enter by the specified date on the action deadline webpage.

A7.5 Registration Fees

North American Competitions – Payment for registration fee must be initiated within 48 business hours of registration.

A7.6 Withdrawals

Registered teams for the Baja SAE® North American event that find that they will not be able to attend the competition are required to officially withdraw CDS Staff (collegiatecompetitions@sae.org) no later than (4) weeks before the event. **Registration fees are NOT refundable or transferable.** For events outside North America, please visit the respective competition website for contact information.

A7.8 International Participation – Vehicle Shipping/U.S. Customs

SAE International and the Baja SAE organizers strongly recommend international teams ship their vehicles early in order to allow enough time to compensate for any delays that may occur in clearing U.S. Customs. Please check with the United States Customs Service concerning the regulations governing the temporary importation of vehicles. You may want to consider using the services of freight forwarder who is familiar with the international shipping of racing vehicles.

Vehicle Shipping

Vehicle shipments by commercial carrier must comply with the laws and regulations of nations from which, and to which, the vehicle is being sent. Teams are advised to consult with their shipping company or freight forwarder to be sure their shipment fully complies with all relevant customs, import/export and aviation shipping requirements.

Shipments must be sent with the participating university listed as the receiving party. The competition organizers, SAE International Staff, nor the competition sites can be listed as the receiving party for your vehicle.

Vehicle shipping procedures for the North American competitions are published on the Baja SAE® website for each competition and are incorporated into these Rules by reference. Neither SAE International staff nor the Baja SAE® competition organizers are permitted to provide advice on U.S. Custom matters.

ARTICLE 8: RULES QUESTIONS

A8.1 Questions:

By submitting a rules question to on www.bajasae.net, you and your team agree that both your question and the Committee's answer can be reproduced and distributed by SAE International, in both complete and edited versions, in any medium or format anywhere in the world.

A8.2 Question Types

The Baja SAE® Committee will answer questions that are not already answered in the rules or FAQs or that require new or novel rule interpretations. The Committee will not respond to questions that are already answered in the rules. For example, if a rule specifies a minimum dimension for a part the Committee will not answer questions asking if a smaller dimension can be used.

A8.3 Question Submission

An electronic question submission system has been developed for the North American competitions. The current submission instructions are published on www.bajasae.net, accessible by clicking "Submit a Rules Question" on the Quick Links menu on the right.

A8.3.1 Question Documentation

Teams submitting questions are required to bring copies of the questions and answers with them to technical inspection.

A8.4 Response Time

Please allow a minimum of two (2) weeks for a response. The National Techs will respond as quickly as possible, however responses to questions presenting new issues, or of unusual complexity, may take more than two weeks.

NOTE: Please keep in mind that final operating approval of any Baja SAE® vehicle can only be given on site at the competition.

A8.5 Event-Related Questions

Questions pertaining to the operation and schedules of specific Baja SAE® competitions should be emailed to CDS directly at collegiaticompetitions@sae.org.

ARTICLE 9: PROTESTS/APPEALS

It is recognized that hundreds of hours of work have gone into fielding a vehicle. In the heat of competition, emotions peak and disputes can arise. The organizers and SAE International staff will make every effort to fully review all questions and resolve problems quickly and efficiently.

A9.1 Preliminary Review – Required

If a team has a question about scoring, judging, policies or any official action it must be brought to the organizer's or SAE International staff's attention for an informal preliminary review.

Preliminary Review - Problem Report

If a team has a question about one of their results/scores they can file a Problem Report using the mobile.bajasae.net website while at the competition site. Additional details about how to file a Problem Report will be available at the competition site or on mobile.bajasae.net. A Problem Report is not a formal protest but should be initiated prior to a formal protest if possible

A9.2 Cause for Protest/appeal

A team may protest any rule interpretation, score or official action (unless specifically excluded from protest) which they feel has caused some actual, non-trivial harm to their team, or has had a substantive effect on their score. Teams may not protest rule interpretations or actions that have not caused them any substantive damage.

A9.3 Protest Format and Forfeit

All protest must be filed in writing and presented to the organizer or SAE Staff by the team captain or a designated student team member. In order to have a protest considered, a team must post a twenty-five (25) point protest bond which will be forfeited if the protest is rejected.

(SAE International staff, judges or volunteers will not review any video footage as part of the protest.)

A9.4 Protest Period

Protests concerning any aspect of the competition must be filed within one half hour (30 minutes) of the end of the event to which the protest relates.

A9.5 Decision

The decision regarding any protest is final.

PART B: TECHNICAL REQUIREMENTS

ARTICLE 1: GENERAL DESIGN REQUIREMENTS

B1.1 Vehicle Configuration

The vehicle must have four (4) or more wheels not in a straight line.

B1.1.1 The vehicle may only use one Briggs & Stratton engine of a model specified below. The vehicle must be capable of carrying one (1) person 190cm (75 in) tall weighing 113kg (250lbs).

B1.1.2 Maximum Vehicle Dimensions

Width: 162 cm (64 in) at the widest point with the wheels pointing forward at static ride height.

Length: Unrestricted, see note below.

NOTE: Teams should keep in mind that Baja SAE® courses are designed for vehicles with the maximum dimensions of 162 cm (64 in) width by 274 cm (108 in) length.

B1.2 All-Terrain Capability

B1.2.1 The vehicle must be capable of safe operation over rough land terrain including obstructions such as rocks, sand jumps, logs, steep inclines, mud and shallow water in any or all combinations and in any type of weather including rain, snow and ice.

B1.2.2 The vehicle must have adequate ground clearance and traction.

B1.3 Vehicle Ergonomic Capacity

As a prototype of a commercial product, the design intent **must** accommodate drivers of all sizes from the 95th percentile male (in the country in which the competition is held) to the 5th percentile female. The largest driver must be able to meet the roll cage minimum clearances, and fit into a comfortable driving position, while wearing the entire required driver's equipment. The smallest driver must be able to comfortably reach all of the vehicle's controls.

ARTICLE 2: REQUIRED ENGINE (NEW)

B2.1 Briggs & Stratton 10 hp OHV Intek, Model 19

For over thirty years, the Briggs & Stratton Corporation has generously provided engines to the Baja SAE® teams.

Teams will pay \$250.00 for shipping and handling of the required engines.

- ✓ **You must order your engine by November 14, 2016.**
- ✓ **No exceptions.**

A maintenance kit will not be provided with the new engine. Parts and accessories can be ordered through www.briggsandstratton.com

B2.3.1 Engine Shipment outside the U.S. & Canada

Teams from countries outside of the continental United States and Canada will need to have their engines shipped:

A. To the organizer of the competition they have registered for and where it will be held for the team's arrival at the competition.

Or

B. To an address in the United States provided by the participating team.

B2.3.2 Briggs & Stratton will not ship engines outside of the continental United States or Canada, international orders must follow one of the shipping methods listed above as exporting is not an option. If for any reason the engine fails to arrive, due to a team's third party shipper, it will not be replaced.

B2.3.3 Neither Briggs & Stratton nor SAE International assume any responsibility for the delivery of engines.

Teams requesting that engines be shipped to the organizer will be responsible for installing the engine prior to technical inspection and will need to bring the tools necessary to install the engine onsite. Teams should also get permission from the organizer, to use their facility if necessary.

B2.4 Purchasing of Additional Briggs & Stratton Engines

Teams may purchase additional Briggs & Stratton engines directly through their local Briggs & Stratton dealer. There is no special discount or purchase price for additional engines.

B2.5 Engine Requirement and Restrictions (NEW)

To provide a uniform basis for the performance events, all vehicles must use the same engine: a stock four cycle, air cooled, Briggs & Stratton OHV Intek Model 19.

The only engine model accepted at all 2017 Baja SAE North American competitions is Briggs & Stratton model number:

19L232-0054-G1

No other engine models will be accepted. No engine models from previous competition years will be accepted.

The new Model 19 engine is not equipped with an engine mounted fuel tank. A Briggs and Stratton fuel tank and cap are required to be procured separately from the engine. See section B12.3 for specification on the required fuel tank and remote mounting requirements.

Teams can use existing fuel tanks and caps or order parts below:

Tank part number is 799863

Roll over cap- B4325GS

Consumable parts are order-able on the Briggs & Stratton Web site: (no engines)

www.briggsandstratton.com

The required engine must remain completely stock in all ways.

NOTE: Blueprinting (reworking an engine to a manufacturer's exact specifications) is considered to be a modification and prohibited.

B2.5.1 Replacement Parts

Only Original Equipment Briggs & Stratton replacement parts may be used. Consumable parts maybe ordered on the Briggs & Stratton Web site: www.briggsandstratton.com or procured from a Briggs & Stratton dealer.

B2.5.2 Piston Rings

Only standard size original Briggs & Stratton piston rings may be used.

B2.5.3 Intake Ports

No cleaning or removing of aluminum flashing from intake or exhaust ports may be done.

B2.5.4 Valves

A. Valve Clearance

Any valve clearance setting between tappet and valve stem – intake and exhaust may be set.

B. Valve Lapping

Valves may be lapped to ensure proper sealing. Intake angle must remain at 45 degrees; exhaust angle must remain at 45 degrees.

B2.5.5 Shafts and Rods

Camshaft, crankshaft, connecting rod and flywheel must not be altered or modified.

B2.5.6 Spark Plugs

Must use RC12YC Only.

B2.5.7 Armature

Any armature air gap setting is allowed. No slotting or elongating of armature mounting holes to increase or retard ignition timing.

B2.5.8 Flywheel Rotation

No flywheel rotation to advance or retard timing is permissible.

B2.5.9 Carburetor

A. Carburetor Re-jetting – Prohibited

This is a fixed carburetor, re-jetting of the carburetor is prohibited.

B. Idle Speed

Any idle speed adjustment is allowed, Briggs & Stratton recommends 1750, ± 100 RPM.

C. Carburetor Float

Carburetor float is non-adjustable and may not be re-adjusted.

D. Carburetor Venturi

Modification of carburetor venture is prohibited.

B2.5.10 Air Cleaner

The air intake may be relocated, but Briggs & Stratton parts must be used to relocate the air filter: 592251 remote kits, 695329 – choke shaft and 699960 bases. No other previous versions will be allowed. The supplied air hose may be shortened to a minimum of 152 mm (6.0 in). No other type of hose will be allowed. A team may also add additional pre-filters to the top of the air intake. These parts must be included on the cost report. Any changes made to the air filter will have to pass Briggs & Stratton inspection.

Note from Briggs & Stratton: Relocation of the air cleaner may decrease engine performance.

B2.5.11 Exhaust System

A. Muffler Relocation

If the vehicle design requires an exhaust system reconfiguration to keep it from impinging on part of the vehicle, the re-routing must be done using tubing having an ID of 32mm (1.25 in). Any remote mounted exhaust system must use the original muffler and must be securely mounted so that it does not vibrate loose during the competition.

B. Muffler Support

Supports for the exhaust pipe and muffler are required. Supports **must** be attached exclusively to the engine.

C. Exhaust Pipe

Exhaust pipe may not protrude inside of the exhaust port, so as to alter port configuration.

D. Exhaust Pipe – Length

Any exhaust pipe length is allowed, however pipe length may not be adjustable.

E. Exhaust Pipe – Holes & Tubes

No extra holes or tubes are allowed in the exhaust pipe.

F. Exhaust System – Durability Required

The exhaust pipe and muffler must be completely intact and operational throughout the competition. Any vehicle found to have a loose or leaking exhaust system will be removed from competition until the issue can be corrected.

B2.5.12 Starter

The Recoil starter rope may be extended to accommodate the driver starting the engine while seated.

B2.5.13 Alternator

The engine may be fitted with an alternator to generate electrical energy. The only alternators which may be used are those which Briggs & Stratton specifies for the engine model. Available charging system includes 3, 10 and 20 AMP systems.

B2.5.14 Engine Governor

Each engine is equipped with a governor. Each governor will be set at competition to a 3,800 rpm or lower maximum speed. Random inspection of the governor may be conducted at any time. Any attempt to defeat the engine governor so as to increase the engine speed is grounds for immediate disqualification. Random inspection of the governor may be conducted at any time.

GOVERNOR SETTING NOT TO EXCEED 3800 RPM.

The governor operation must remain free of obstructions at all times. Governor area must be shielded from debris.

All tanks must be remote mounted. For remote mounted tanks a debris shield covering the exposed governor area is required. Briggs & Stratton part number 697326 Control Cover may be used or some other part with equivalent features.

NOTE: The governor spring must be placed in hole #5.

Governor spring goes into hole 5 which is different than years past.
part number for Governor spring is 264080.

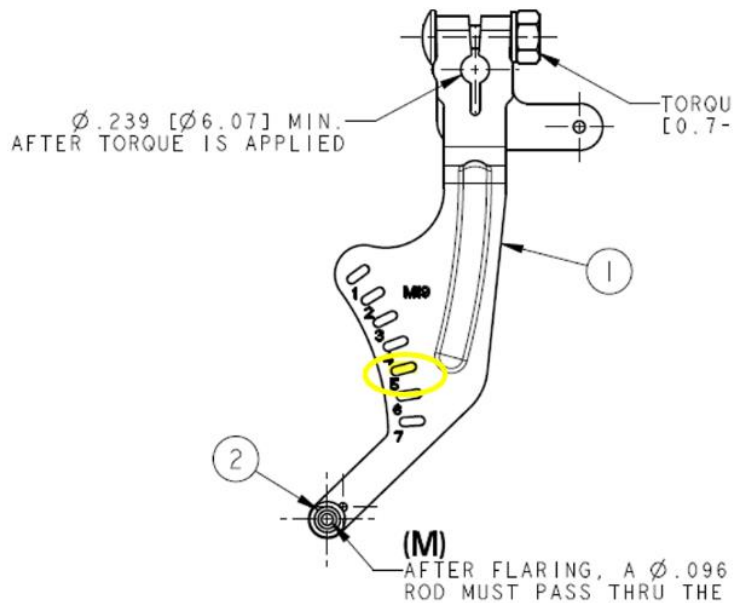

B2.5.15 Hybrid Electric Power Systems

Hybrid / electric power systems are specifically prohibited.

B2.5.16 Energy Storage Devices Used for Propulsion

Hydraulic accumulators are the only type of stored energy device that may be incorporated into the vehicle for propulsion purposes. Hydraulic power systems must be properly shielded and documentation of the shielding made available for review.

Flywheels and similar types of rotating inertia storage devices are prohibited.

Compressed Gas systems are allowed to change transmission states (i.e. shift gears), but not to provide additional Power.

Compressed Gas Cylinders and Lines

Any system on the vehicle that uses a compressed gas as an actuating medium must comply with the following requirements:

- Working Gas-The working gas must be nonflammable, e.g. air, nitrogen, carbon dioxide.
- Cylinder Certification- The gas cylinder/tank must be of proprietary manufacture, designed and built for the pressure being used, certified by an accredited testing laboratory in the country of its origin, and labeled or stamped appropriately.
- Pressure Regulation-The pressure regulator must be mounted directly onto the gas cylinder/tank.
- Protection – The gas cylinder/tank and lines must be protected from rollover, collision from any direction, or damage resulting from the failure of rotating equipment.
- Cylinder Location- The gas cylinder/tank and the pressure regulator must be located either rearward of the Main Roll Hoop and within the envelope defined by the Main Roll Hoop and the Frame or in a structural side-pod.
- Cylinder Mounting- The gas cylinder/tank must be securely mounted to the Frame, engine or transmission.
- Cylinder Axis- The axis of the gas cylinder/tank must not point at the driver.
- Insulation- The gas cylinder/tank must be insulated from any heat sources, e.g. the exhaust system.
- Lines and Fittings- The gas lines and fittings must be appropriate for the maximum possible operating pressure of the system.

B2.6 Engine Use Restriction

Briggs & Stratton generously provides engines to the teams for the exclusive purpose of use on their Baja SAE® vehicle. If, for any reason, a team receives an engine and at a later date decides not to participate, it must, at its own expense, return the engine to SAE International or Briggs & Stratton.

ARTICLE 3: ELECTRICAL SYSTEM

B3.1 General Electrical System Overview

The electrical system must include at least two kill switches, a brake light, and a battery power source. The kill switches must deactivate the engine ignition. The brake light, any reverse light and alarm, must operate regardless of the kill switch setting. The brake light, any reverse light and alarm, must be powered and functional at all times. Cut-out or disabling switches to the brake light and reverse light (if so equipped) are prohibited.

B3.2 Batteries

B3.2.1 Batteries must be mounted with sound engineering practice and not come loose during a roll over.

B3.2.2 Non-recharging batteries

Batteries which are not recharged by an engine alternator may power only safety items (brake light, reverse light and alarm) and instrumentation (driver display, data acquisition), and may not power any control or actuation function in the drivetrain, steering and suspension systems.

B3.2.2.1 Batteries must be able to provide power to safety items (brake light, reverse light and alarm) for the duration of each event.

B3.2.2.2 Vehicles will be black flagged if safety equipment is not functioning.

B3.2.2.3 The batteries must be factory sealed (incapable of being opened or serviced) and not leak in the event of a roll over.

B3.2.3 Recharging batteries

Only batteries which are recharged by an engine alternator may be used to power control or actuation functions in the drivetrain, steering and suspension systems

B3.3 Kill Switches

Each vehicle must be equipped with two (2) easily accessible kill switches turning off the ignition. The Kill switch must not de-energize the Brake.

B3.3.1 Kill Switch – Type (Updated)

B3.3.1 Kill Switch – Type NEW

The kill switches must be one of the following:

(A) Stock Polaris # 4013381

(B) 01-171 Ski-Doo kill switch available at <http://www.mfgsupply.com/01-171.html>

(C) Aftermarket WPS#27-0152 or 27-0124 <http://www.parkeryamaha.com/skidoostopswitch.aspx>

Note: Kill switches that were of an older version of the approved switches will be allowed.

B3.3.2 Kill Switch – Locations and Orientation

(A) **Cockpit Switch** – The cockpit switch must be located in the front of the cockpit within easy reach of the driver with the safety harness tight. The switch may not be mounted on a removable steering wheel assembly.

"Any fasteners used in securing the cockpit kill switch shall be B14.1 compliant"

External Switch – The external switch must be mounted on the driver's right side of the vehicle, on a panel generally perpendicular (it can be mounted between the RRH and FAB tubes) to the firewall (+/- 15 degrees) between RRH and Rear Bracing within the red area, (Fig 2) and behind the plane of the RRH. The switch cannot be more than 178 mm (7 in) vertically below point. BR. The switch must be within easy reach of track workers, the switch must be mounted rigidly, with no sharp edges nearby. It must not be necessary to reach inside the roll cage to actuate the switch.

"Any fasteners used in securing the external kill switch shall be B14.1 compliant"

Sample Mountings (Note: The kill switches must be mounted using the outer cases. If they are mounted using adhesive on the back cover the switch will fail. Adhesives are prohibited)

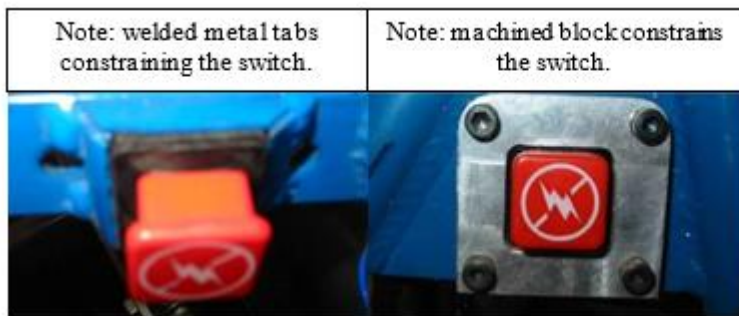

Figure 1

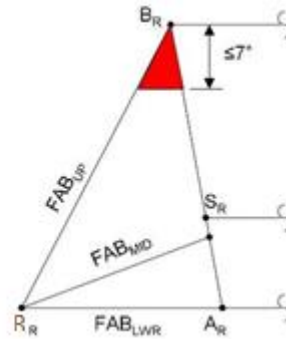

Figure 2

B3.3.3 Wiring

All wiring must be sealed, protected and securely attached.

B3.4 Brake Light

Brake light must not be modified or altered from original, purchased design. The brake light shall be illuminated when the brake system is actuated, and completely extinguished when the brakes are released. (I.e. No running lights rear of the firewall). The brake light must be mounted at a minimum of 1 meter (39.4 in) above the ground. Light must be mounted such that it **shines rearward and parallel** to the ground or pitched slightly downward, not up at an angle.

B3.4.1 Brake Light – TYPE

The SAE rated brake light must be one of the following:

- (A) Polaris Part # 2411450
- (B) Polaris Part # 2411099
- (C) Polaris Part # 2411092-432
- (D) Haul-Master – Part # 93263
- (E) Command Electronics Part # 003-6018R
- (F) Command Electronics Part # 003-6016

B3.5 Brake Light Switch

The brake light must be activated by hydraulic pressure switches. Each independent brake hydraulic circuit must be equipped with a brake light switch, so that no brake, including cutting brakes may be activated without lighting the brake light. This means each vehicle is required to have a minimum of two (2) hydraulic pressure switches.

Note: **Push style or momentary switches are not allowed.**

B3.6 Reverse Light and Alarm

Vehicles with reverse must be equipped with a backup light marked with an SAE “R” on the lens **and be of LED** design, equal to, or exceed the SAE standard J759. The reverse light must be mounted at a minimum of 70 cm (27.6 in) above the ground. Vehicles with reverse must also be equipped with a backup alarm. The alarm must be rated per SAE standard J1741 or J994 and sound whenever the vehicle is in reverse.

B3.7 Instrumentation and Data Acquisition

B3.7.1 Live Data or Driver Feedback Instrumentation and Data Acquisition

Systems that provide live information about the cars operation or performance are allowed. Any system that provides data back to the driver or team track side must be included on the Cost Report. Additionally, any batteries used to power the system must comply with the battery rules in Section B3.2.

B3.7.2 Data Loggers and Event Recorders

Systems that do not provide live information about the cars current operation or performance are allowed. Any data or event recording system that cannot provide data back to the driver or team track side can be excluded from the Cost Report. Additionally, any batteries used to power the system must comply with the battery rules in Section B3.2.

B3.7.3 Mixed Use Instrumentation and Data Acquisition

Any system that is used as part of live data or driver feedback instrumentation system as well as a component of a control or actuation mechanism for the drivetrain, steering and suspension systems must be included on the Cost Report. Additionally, any batteries used to power the system must comply with the Recharging batteries rule in Section B3.2.3

ARTICLE 4: TOWING HITCH POINT

B4.1 Each vehicle must have towing hitch points at the front and rear, along its longitudinal centerline. These hitch points are used both for dynamic events and for vehicle recovery. Hitch points must be structurally attached to the vehicle's main structure, and must allow for transmission of both longitudinal and lateral towing loads from the vehicle to the hook or clevis of a tow rope without entanglement in vehicle components.

B4.2 Front and Rear Hitch Points

The hitch points must be strong enough to serve as a vertical lift points for the vehicle. The hitch points, when not attached to a tow rope, may not present a danger of penetration in the event of a collision.

B4.2.1 Front Hitch Point Requirements – Maximum and Minimum

Front Hitch Point Requirements –Maximum and Minimum

Maximum diameter 31.75 mm (1.25 in.), Minimum diameter 25.4mm (1in.)

Minimum wall thickness of 0.89 mm (.035 in)

Hitch point height must be no higher than the SIM and no lower than the LFS

The hitch gauge shown in Figure 3. 50.8 X 50.8 X 203.2 mm (2" X 2" X 8" in.) must be able to pass completely behind the front hitch.

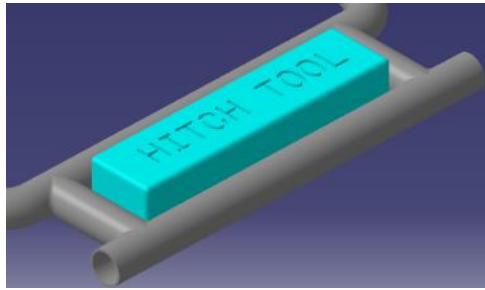

Figure 3

B4.2.2 Rear Hitch Point Requirements – Maximum and Minimum

Towing plate Minimum / Maximum thickness – 3.18 mm (.125 in) / 9.5 mm (.375 in)

Hole diameter Minimum / Maximum – 25.4 mm (1 in) / 31.75 mm (1.25 in)

Radial clearance Minimum / Maximum from hole – 15.875 mm (0.625 in) / 25.4 mm (1.0 in)

Hole to tube Minimum / Maximum clearance – 19.0 mm (.75 in) / 25.4 mm (1.0 in)

Hitch plate Minimum width where connected to frame – 76.2 mm (3.0 in)

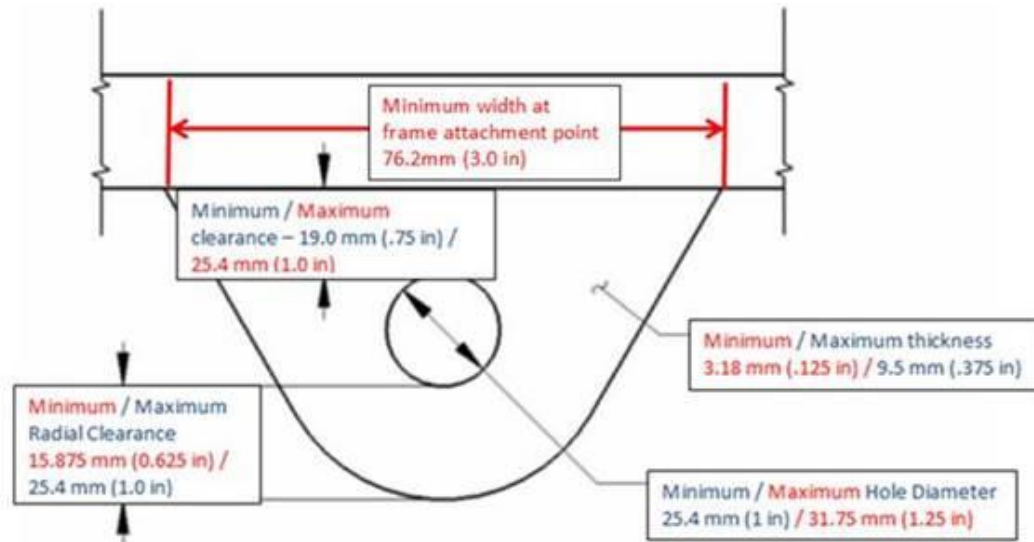

Figure 4

ARTICLE 5: VEHICLE IDENTIFICATION

B5.1 Number Assignment and Positioning

U.S and Canadian competitions: Numbers are automatically assigned as part of the online registration. Assigned numbers may be found on the Baja SAE® website in the “Registered Team List” for each competition.

B5.1.1 Other competitions: Vehicle numbers at other competitions will be assigned by the respective organizers.

B5.1.2 Three primary numbers are required to be securely affixed to the car. One on both of the upper sides of the frame behind the roll hoop, clearly visible in a side view.

One must also be visible from a front view. For numbers mounted above the SIM, the angle between the plane of the front-facing numbers and the vertical must be less than or equal to 45°. For numbers mounted below the SIM, this angle must be less than or equal to 15° from vertical.

Numbers that are not easily read might not be scored during the endurance event.

B5.1.3 Number Location

Three primary numbers are required to be securely affixed to the car. One on both of the upper sides of the frame behind the roll hoop, clearly visible in a side view. One must also be visible from a front view.

B5.1.4 Number Size

The primary cutout numbers must be at least 203 mm (8 in) high. These have a minimum line width of 25 mm (1 in.) and 102 mm (4 in) wide. The numbers must strongly contrast with the numeral background color.

COMMENT: Schools which are entering more than one vehicle should consider painting them in individually distinctive colors to facilitate in lap counting.

COMMENT: Avoid sharp edges or points on the inner and outer edges of the cutout numbers.

B5.2 Vehicle Number – Primary Cutout

B5.2.1 Each vehicle must have numbers where the outer face is a minimum of (one half inch) .5 inches from the backing panel of contrasting color an example of which is shown in the figures. The number must be a block style numeral that is clear and easy to read. Vehicles with numbers that are hard to read, missing, damaged or obscured may not be scored and may be black flagged. It is recommended that the numbers be outlined as well to further provide contrast.

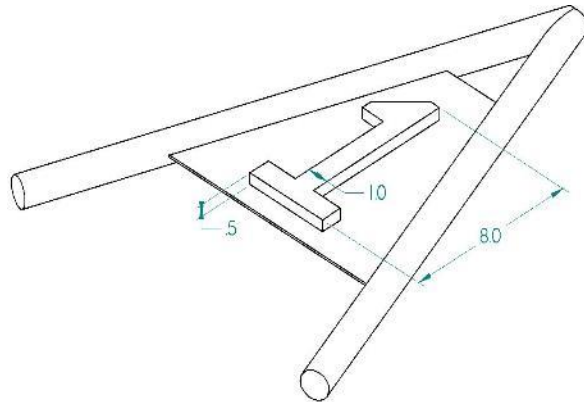

Figure 5

B5.3 SAE International Logo

Two (2) SAE International logos must be displayed on the vehicle in prominent locations. These will be distributed during registration at the competition.

B5.4 Sponsor Identification

Teams may display advertising from their vehicle's sponsors, provided it is in good taste and does not conflict with the vehicle's number. SAE International may require all entrants to display advertising from the competition sponsors.

ARTICLE 6: TRANSPONDERS

B6.1 Transponders – US and Canadian Competitions

Transponders may be used as part of the primary timing system for all closed loop dynamic events at competitions in the US and Canada.

B6.1.1 Vehicles must carry a functional, properly mounted and fully charged transponder of the specified type. Vehicles without a specified transponder will NOT be allowed to compete in any event for which a transponder is used for timing.

Use of transponders at competitions outside of the US and Canada is at the option of the organizer.

B6.2 Transponder Requirement (Updated)

All vehicles must be equipped with at least one AMB / MYLAPS rechargeable transponder. The ONLY acceptable types are the Classic MX, Flex MX, and X2 MX. Subscriptions for Flex MX or X2 MX transponders MUST be current and these types of transponders must have been activated prior to Transponder Check at Technical Inspection. The timing system is capable of recording two transponder identifications per vehicle; therefore, a second transponder may be mounted as a backup if desired.

Visit <http://www.mylaps.com> for more information on purchasing transponders.

The timing system is capable of recording two transponder identifications per vehicle; therefore, a second transponder may be mounted as a backup.

B6.3 Transponder Purchase

All teams are responsible for purchasing their transponder directly through AMB (recently acquired by MyLaps). <http://www.mylaps.com>

B6.4 Transponder Mounting

B6.4.1 Each transponder is supplied with a mounting bracket (SEE PHOTO). Teams are advised to weld a small plate to their frame to attach the bracket. The bracket can be attached with rivets, zip ties or bolts. Comments: Attaching the bracket with an M4 pan OR flat head bolts with lock nuts OR wire is strongly suggested. It is the orange unit!

B6.4.2 Transponder mounting requirements:

- A. Orientation – The bracket must be mounted vertical to the frame in the orientation shown in the photograph and oriented so the transponder number can read “right-side up.”
- B. Location – The transponder must be mounted on the driver’s right side forward of the seat and preferably within the lower horizontal plane of the front suspension. The transponder must be no more than 61 cm (24 in) above the track.
- C. Unobstructed – There must be an open, unobstructed line between the antenna on the bottom of the transponder and the ground. (Do not mount the transponder inside the vehicle if sight line is obstructed.) Metal and carbon fiber may interrupt the transponder signal. The signal will normally transmit through fiberglass and plastic. If the signal will be obstructed by metal or carbon fiber, a 10.2 cm (4 in) diameter opening can be cut and the transponder mounted flush with the opening.
- D. Protection – Mount the transponder where it will be protected.

Suggested Mounting Locations (Right Front of Vehicle)



Bracket Dimensions (mm)

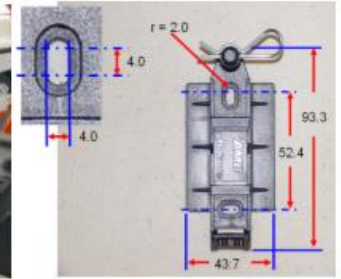

Figure 6

B6.5 Transponder Black Flag

If, for any reason, a vehicle’s transponder is not being received by the timing system, the vehicle could be black flagged for transponder repair, relocation or replacement.

ARTICLE 8: ROLL CAGE

B8.1 Objective

The purpose of the roll cage is to maintain a minimum space surrounding the driver. The cage must be designed and fabricated to prevent any failure of the cage's integrity.

B8.2 Lateral Space

Minimum space is based on clearances between the driver and a straight edge applied to any two points on the roll cage; an example is shown. The driver's helmet shall have 152 mm (6 in.) clearance, while the driver's shoulders, torso, hips, thighs, knees, arms, elbows, and hands shall have 76 mm (3 in.) clearance. Clearances are relative to any driver selected at technical inspection, seated in a normal driving position, and wearing all required equipment.

For any member to be a part of the roll cage, that member must conform to B8.3.1, otherwise it is assumed to have no contribution (a-arms are an example of members which do not conform to B8.3.1). If there are any triangulating members joining the RHO to the vertical members of the Rear Roll Hoop (RRH-B8.3.2), and these triangulating members conform to B8.3.12, then the virtual side surfaces may be extended by an outboard crease over the triangulating members.

The driver's helmet shall have 152 mm (6 in.) clearance to the side surfaces.

The driver's shoulders, torso, hips, thighs, knees, arms, elbows, and hands shall have 76 mm (3 in.) clearance to the side surfaces.

B8.2.1 Vertical Space

The driver's helmet shall have 152 mm (6 in.) clearance from any two points among those members that make up to top of the roll cage. These members are: the RHO members (exclusive of any covering or padding); the RRH upper, LC; and the LC between points C. In an elevation (side) view, no part of the driver's body, shoes, and clothing may extend beyond the envelope of the roll cage.

8.3 Roll Cage Structure

B8.3.1 Elements of the Roll Cage

The roll cage must be a space frame of tubular steel. The required members of the roll cage are illustrated in RC1. Primary members must conform to B8.3.12.

Primary members are:

- RRH: Rear Roll Hoop
- RHO: Roll Hoop Overhead Members
- FBM: Front Bracing Members
- ALC: Aft Lateral Cross Member in Rule B8.3.3
- BLC: Overhead Lateral Cross Member
- FLC: Front Lateral Cross Member in Rule B8.3.4
- CLC: Upper Lateral Cross Member
- DLC: SIM Lateral Cross Member
- LFS: Lower Frame Side Members

Secondary members must be steel tubes having a minimum wall thickness of 0.89 mm (.035 in) and a minimum outside diameter of 25.4 mm (1.0 in):

Secondary members are:

- LDB: Lateral Diagonal Bracing
 - SIM: Side Impact Members
 - FAB: Fore/Aft Bracing Members
 - USM: Under Seat Member
 - RLC: Rear Lateral Cross Member
- Any tube that is used to mount the safety belts or fuel tank

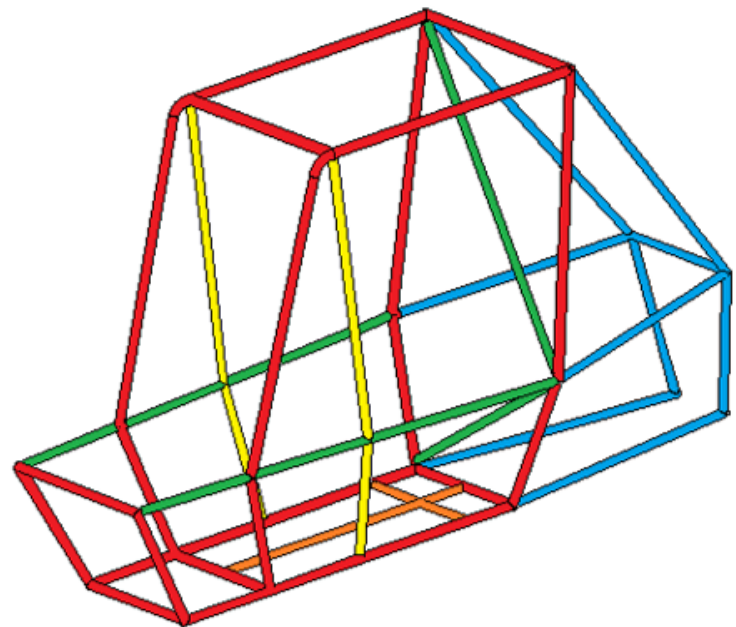

- Primary Members
- Secondary Members
- Secondary Members FAB (B8.3.9.1)
- Secondary Members FAB (B8.3.9.2)
- Secondary Members USM (B8.3.7)

RC1

B8.3.1.1 Roll Cage Member Requirements (UPDATED)

Roll Cage Member Requirements Roll cage members must be made of steel tube, and may be straight or bent. Straight members may not extend longer than 1016mm (40 in.) between Named Points. Bent members may not have a bend greater than 30° that does not occur at a Named Point; and may not extend longer than 838 mm (33 in.) between Named Points. Small bend radii (<152 mm, 6 in.) that terminate at Named Points are expected, and are not considered to make a member bent, regardless of angle. A bend that terminates at a Named Point implies the point lies between the tangents of the bend, as shown in RC2. Required dimensions between roll cage members are defined by measurements between member centerlines, except where noted.

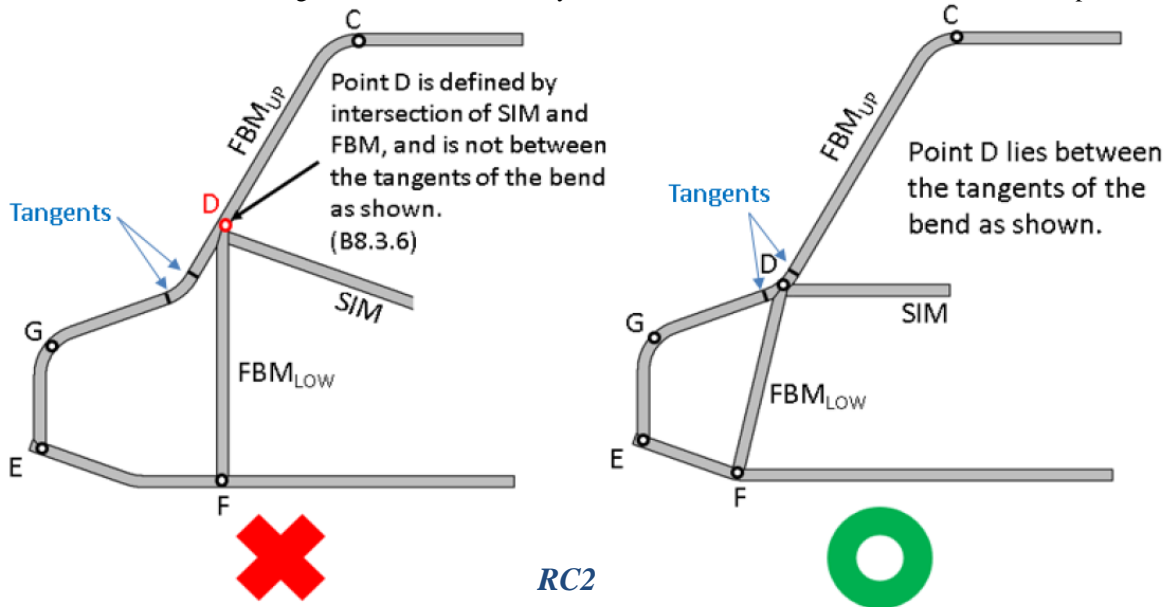

Additional Support Members

For bent or straight Roll Cage Members that exceed the maximum allowable length, additional support members may be added. For straight members, a single secondary member should connect from the mid-point (+/- 5in) to a Named Point. For bent members, a single secondary member should connect from between the tangents of the bend to a Named Point. At no time may a bent member have a bend greater than 30°.

Named Roll Cage Points: A, B, C, D, F, S, (E and/or G for ‘Nose’ cars) and P, Q, and R as applicable for FAB systems. All named points are implied to have a Left and Right hand side, denoted by subscript L or R (e.g. A_L and A_R) as shown in RC3.

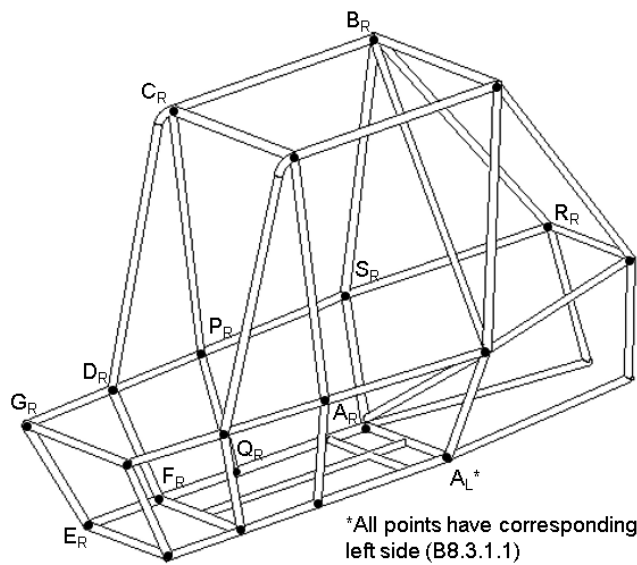

B8.3.2 Lateral Cross Member Requirements

Lateral cross members cannot be less than 203.5 mm (8 in) long. They cannot have a bend; however, they can be a part of a larger, bent tube system, provided the minimum length is met between bend tangents. The cross members which connect the left and right points A, B, C, D, F and E/G for ‘Nose’ cars (in which case DLC may be omitted) must be made of primary materials. LCs are denoted by the points they connect (e.g. ALC, FLC, etc.).

B8.3.3 Rear Roll Hoop (RRH)

The RRH is a structural panel behind the driver’s back, and defines the back side of the roll cage. The driver and seat must be entirely forward of this panel. The RRH is substantially vertical, but may incline by up to 20° from vertical. The minimum width of the RRH, measured at a point 686 mm (27 in.) above the inside seat bottom, is 736 mm (29 in.). The vertical members of the RRH may be straight or bent, and are defined as beginning and ending where they intersect the top and bottom horizontal planes (points A_R and A_L, and B_R and B_L in RC4). The vertical members must be continuous tubes (i.e. not multiple segments joined by welding). The vertical members must be joined by ALC and BLC members at the bottom and top. ALC and BLC members must be continuous tubes or adhere to B8.3.10. ALC, BLC, both RRH members, LDB and the shoulder belt tube must all be coplanar.

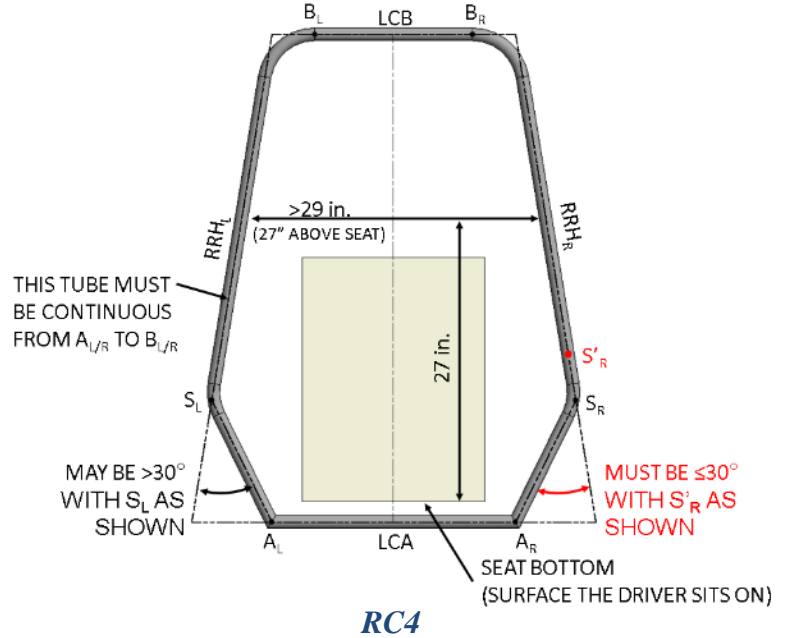

B8.3.3.1 Rear Roll Hoop Lateral Diagonal Bracing (LDB)

The RRH must be diagonally braced. The diagonal brace(s) must extend from one RRH vertical member to the other. The top and bottom intersections of the LDB members and the RRH vertical members must be no more than 127 mm (5in.) from points A and B. The angle between the LDB members and the RRH vertical members must be greater than or equal to 20°. Lateral bracing may consist of more than one member. A single straight LDB is exempt from the maximum length in Rule B8.3.1.1.

B8.3.4 Roll Hoop Overhead Members (RHO)

The forward ends of the RHO members (intersection with the CLC) define points C_R and C_L (RC3). Points C_R and C_L must be between at least 305 mm (12 in.) forward of a point, in the vehicle’s side view, defined by the intersection of the RHO members and a vertical line rising from the aft end of the seat bottom. This point on the seat is defined by the seat bottom intersection with a 101 mm (4 in.) radius circle which touches the seat bottom and the seat back. The top edge of the template is exactly horizontal with respect to gravity.

Points C_R and C_L must also be no lower than the top edge of the template, 1041.4 mm (41 in) above the seat.

Note: The top edge of the template is exactly horizontal with respect to gravity.

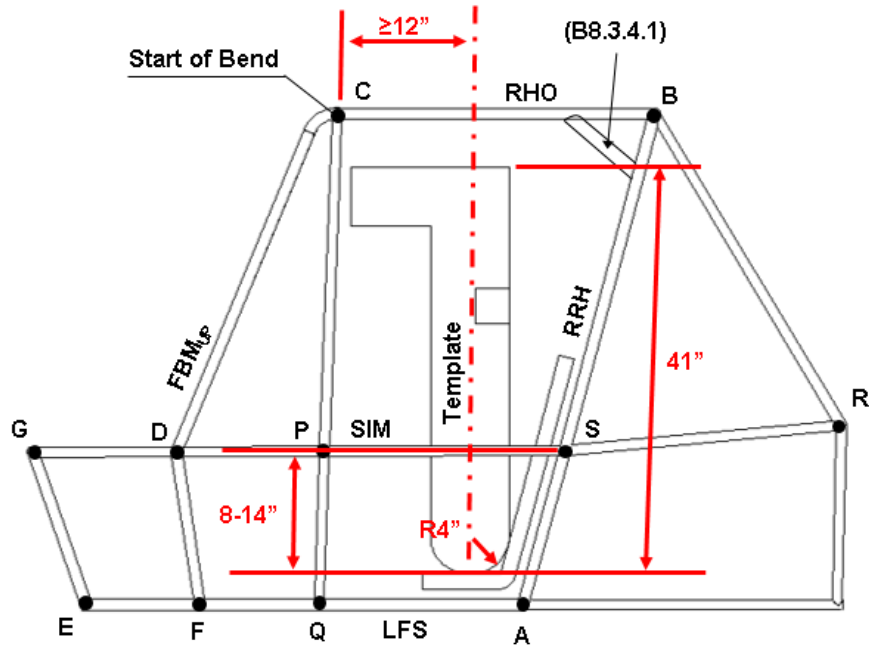

RC5

B8.3.4.1 RHO/RRH Gusseting

If a gusset is used to brace the RHO and RRH to achieve the 6" Lateral Clearance in Rule B8.2, the added tubes must be a primary member (B8.3.12); completely welded around the circumference of both ends of the gusset tube.

B8.3.5 Lower Frame Side Members (LFS)

The two Lower Frame Side members define the lower right and left edges of the roll cage. These members are joined to the bottom of the RRH at Point A and extend generally forward, at least as far as a point forward of every driver's heels, when seated in normal driving position. The forward ends of the LFS members are joined by a lateral cross member, FLC (RC6). The intersection of the LFS members and the FLC define the points FR and FL. In 'Nose' designs, as shown in RC5, the LFS extends forward to Point E, and is joined by a lateral cross member FLC and ELC (RC3).

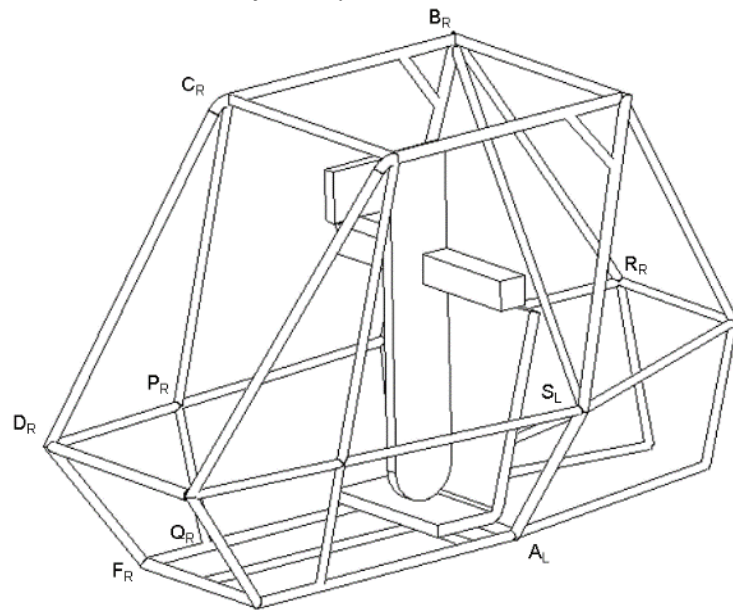

RC6

B8.3.6 Side Impact Members (SIM)

The two Side Impact Members define a horizontal mid-plane within the roll cage. These members are joined to the RRH, defining Point S, and extend generally forward, at least as far as a point forward of every driver's toes, when seated in normal driving position. The forward ends of the SIM members are joined by a lateral cross member, DLC. The intersection of the SIM and DLC define the points DR and DL. The SIM members must be between 203 mm (8 in.) and 356 mm (14 in.) above the inside seat bottom (RC3) at all positions between points S and D. In 'Nose' designs, as shown in RC5, the SIM extends forward to Point G, and is joined by a lateral cross member GLC (RC3). In this case, DLC may be omitted if GLC provides adequate protection for the driver's toes as noted below.

NOTE: Every driver's feet must be entirely behind the plane defined by points FR, L and DR, L. If DLC is below the driver's toes, then an additional primary material Lateral Cross Member must run between the FBM members above the driver's toes. In 'Nose' designs, if GLC is below the driver's toes then an additional primary material Lateral Cross Member must be run between FBM members above the driver's toes.

B8.3.7 Under Seat Member (USM)

The USM must be positioned in such a way to prevent the driver from passing through the plane of the LFS in the event of seat failure. Two options are given for the USM member:

- (1) The two LFS members must be joined by the Under Seat Members. The USM must and pass directly below the driver where the template in RC3 intersects the seat bottom.

Or

- (2) The ALC and FLC members must be joined longitudinally by the Under Seat Member. The USM must and pass directly below the driver where the template in RC3 intersects the seat bottom.

B8.3.8 Front Bracing Members (FBM)

Front Bracing Members must join the RHO, the SIM and the LFS (Fig. RC5) at Points C, D and F. The upper Front Bracing Members (FBM_{UP}) must join points C on the RHO to points D on the SIM. The lower Front Bracing Members (FBM_{LOW}) must join points D to points F. The FBM must be continuous tubes. The angle between the FBM_{UP} and the vertical must be less than or equal to 45 degrees. If Front FAB, per Rule B8.3.9.1, is used there is no angle requirement between FBM and vertical.

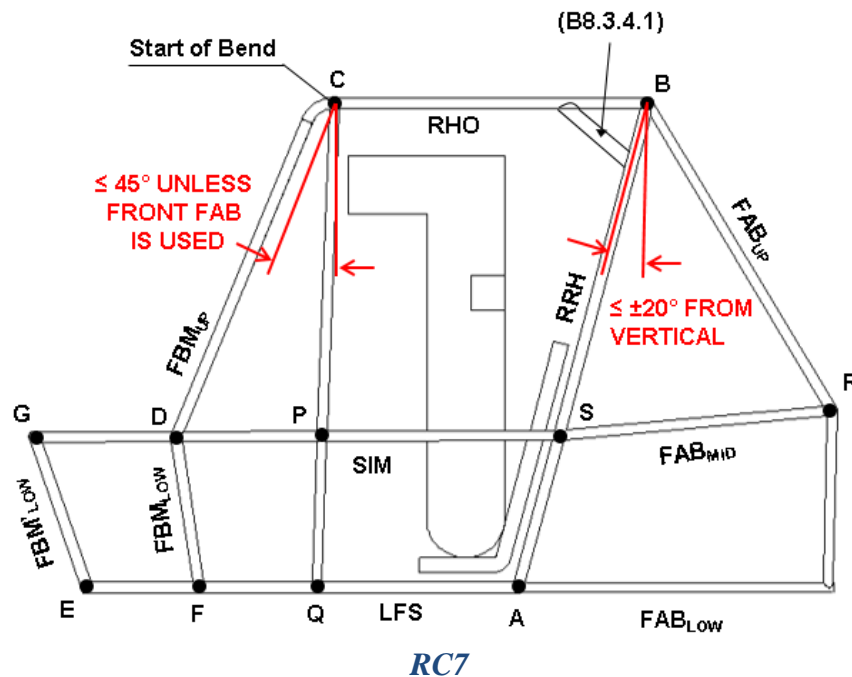

B8.3.8.1 RHO/FBM Gusseting

If the RHO and FBM on one side of the vehicle are not comprised jointly of one tube, bent at point C, then a gusset is required at point C to support the joint between the RHO and the FBM. The total weld length of the gusset must be 2 times the tubing circumference (of the primary material) Thus, if a tube is used to brace the FBM and RHO, it must be a primary tube.

B8.3.9 Fore/Aft Bracing (FAB)

The RRH must be restrained from rotation and bending in the side view by a system of triangulated bracing. Bracing must either: 1) Rear Bracing - directly restrain both points B from longitudinal displacement in the event of failure of the joints at points C; or 2) Front Bracing - restrain both points C from longitudinal and vertical displacement, thus supporting points B through the RHO members. Better design will result if both front and rear bracing are incorporated. Members used in the FAB systems must not exceed 1016 mm (40 in.) in unsupported length. Triangulation angles (projected to the side view) must be at least 20° between members.

B8.3.9.1 Front Bracing

Front systems of FAB must connect the FBM_{UP} members to the SIM members (on the same sides). The intersection with the FBM_{UP} members must be within 127 mm (5 in.) measured as a straight line distance from centerline to centerline of points C. The intersection with the SIM members (defined at Point P) must be vertically supported by further members connecting the SIM members to the LFS members (defined at Point Q).

B8.3.9.2 Rear Bracing

Rear systems of FAB must create a structural triangle, in the side view, on each side of the vehicle. Each triangle must be aft of the RRH, include the RRH vertical side as a member, and have one vertex at Point B and one vertex at either Point S or Point A. The tubes forming this structural triangle must be continuous members; but bends of less than 30° are allowable. The third (aft) vertex of each rear bracing triangle, Point R (Fig. RC6), must additionally be structurally connected to whichever Point, S or A, is not part of the structural triangle. This additional connection is considered part of the FAB system, and is subject to B8.3.1, but may be formed using multiple joined members, and this assembly of tubes, from endpoint to endpoint, may encompass a bend of greater than 30 degrees.

Attachment of rear system FAB must be within 127 mm (5in.) of Point B, and must be within 51 mm (2 in.) of points S and A, on each side of the vehicle. Distances are measured as a straight line distance from centerline to centerline. The aft vertices, at Point R, of the FAB structural triangles must be joined by an LC.

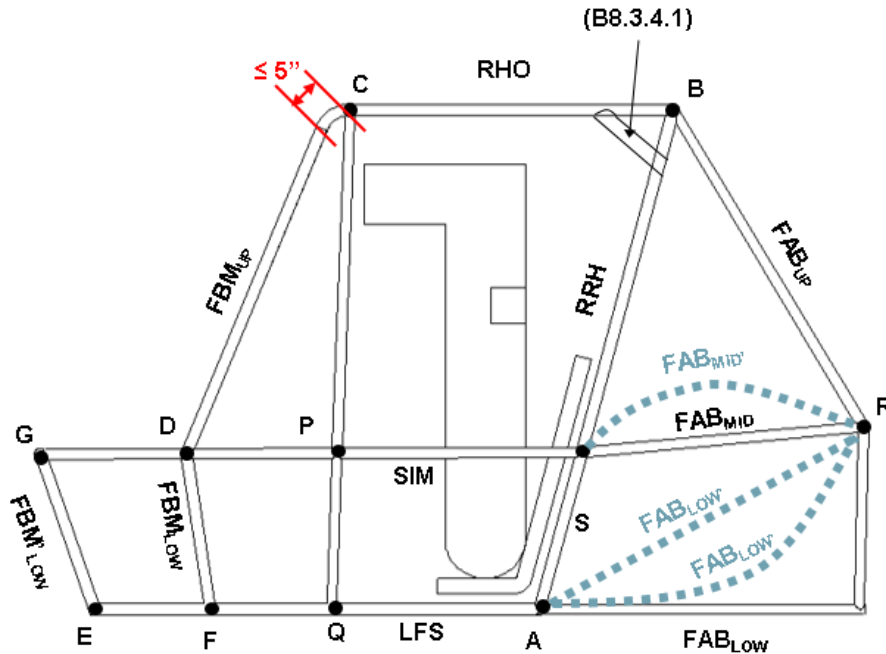

RC8

B8.3.10 Tube Joints

B8.3.10.1 Roll cage element members which are made of multiple tubes, joined by welding, must be reinforced with a welding sleeve. Many roll cage elements are required to be continuous tubes, and may not be made of multiple pieces. Tubes which are joined at an angle need not be sleeved.

B8.3.10.2 Sleeves must be designed to fit tightly on the inside on the joint being reinforced. External sleeves are not allowed. Sleeves must extend into each side of the sleeved joint, a length of at least two times the diameter of the tubes being reinforced, and be made from steel at least as thick as the tubes being reinforced.

B8.3.10.3 The general arrangement of an acceptable sleeved joint is shown in Fig.RC9. A butt weld and four (4) rosette welds (two (2) on each tube piece, on holes of a minimum diameter of 16 mm (0.625 in.) are required.

B8.3.10.4 A minimum of 4 linear inches of weld is required to secure the sleeve inside the joint, including the butt joint and the rosette welds.

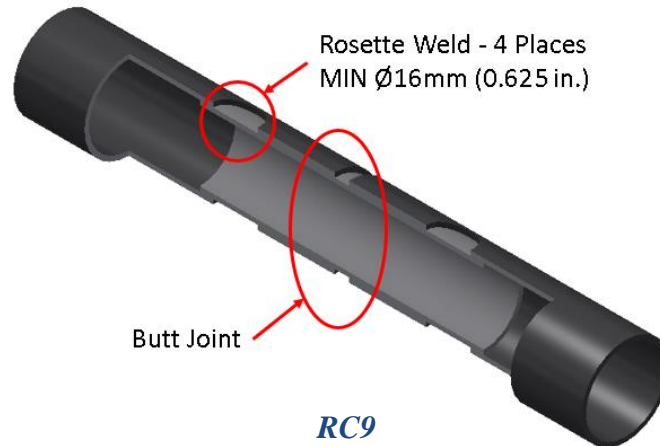

B8.3.11 Welding Process Check

Each person who makes any welded joint on any of the vehicle's roll cage elements must personally make two welding samples, using the same materials and processes as used in the roll cage element welds. All welding samples must be submitted at Technical Inspection. Vehicles for which complete sets of welding samples are not submitted, or for which any of the welding samples are judged inadequate, will not be allowed to compete in dynamic or endurance events. Welding samples must be made from the same tube material, diameter, and thickness as the welds made by each person on the roll cage elements.

(A) Sample 1 – Destructive Testing:

A 90-degree joint, the leg length free (RC10). This joint must be destructively tested causing the joint to fail in the base material (as opposed to the weld metal). The testing method is free-either tensile or bending failure may be induced; however, the peak stress must be located at the weld. In the case of bending failure, take care that the largest bending moment is located at the weld.

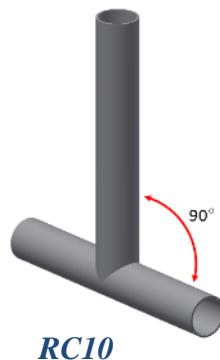

(B) Sample 2 – Destructive Inspection:

Two tubes joined at a 30-degree angle with a length of at least 150 mm (5.9 in.) from the center of the joint (RC11). The sample must be sectioned along the length of tube to reveal adequate and uniform weld penetration (RC12).

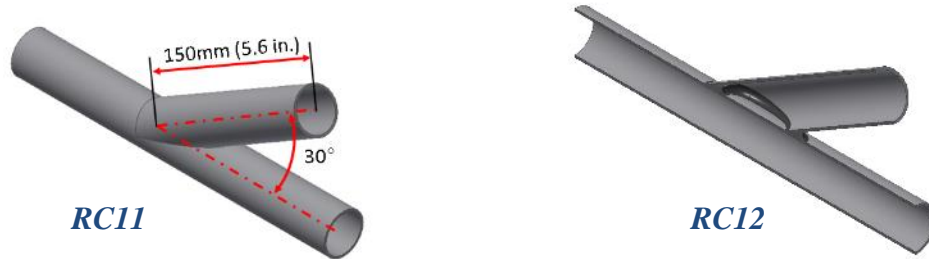

B8.3.12 Roll Cage & Bracing Materials

The material used for the Primary Roll Cage Members must be:

(A) Circular steel tubing with an outside diameter of 25mm (1 in) and a wall thickness of 3 mm (0.120 in) and a carbon content of at least 0.18%.

OR

(B) A steel shape with bending stiffness and bending strength exceeding that of circular steel tubing with an outside diameter of 25mm (1 in.) and a wall thickness of 3 mm (0.120 in.). The wall thickness must be at least 1.57 mm (0.062 in.) and the carbon content must be at least 0.18%, regardless of material or section size. The bending stiffness and bending strength must be calculated about a neutral axis that gives the minimum values.

Bending stiffness is considered to be proportional to:

$$EI$$

E Modulus of elasticity (205 GPa for all steels)

I Second moment of area for the structural cross section

Bending strength is given by:

$$\frac{S_y I}{c}$$

where:

S_y Yield strength (365 MPa for 1018 steel)

c Distance from neutral axis to extreme fiber

Documentation of the equivalency must include:

1. Typed calculations must be presented at Technical Inspection which proves sufficient bending stiffness and bending strength. All calculations must be in SI units, to three significant figures to the nominal tube sizes as specified by the invoice.
2. Invoices of the roll cage materials
3. Material tests or certifications, which specify the carbon content and yield strength.

B8.3.13 Roll Cage Specification Sheet

Each vehicle must present a completed and signed Baja SAE Roll Cage Specification Sheet at Technical Inspection.

Newly completed copies must be presented for each competition

B8.4 Sharp Edges on Roll Cage

The roll cage must have no exposed sharp edges which might endanger the driver or people working around the vehicle while the vehicle is in any attitude (static, dynamic, inverted, etc.).

B8.5 Bolted Roll Cages

B8.5.1 Bolted Roll cages joints are acceptable only if the following requirements are met (RC 13):

- (A) Flanges or tabs must be twice (2X) the thickness of the frame tube, and made of the same material. They must be properly welded to each tubing part to be joined. The face of the flange must be perpendicular to the axis of the frame tube.
- (B) The radius of the flange must be at least 25mm (1 in) larger than the outer radius of the frame tube.
- (C) The gap between faces of the flanges (before being tightened) must be no greater than 0.07 mm (0.003 in).
- (D) The flanges must be attached with at least 3 bolts with a minimum diameter of 8 mm (5/16 in), equally spaced on the flanges. The minimum edge distance between the bolt holes and the edge of the flanges must be twice the bolt diameter.
- (E) Pin Joints and not permitted

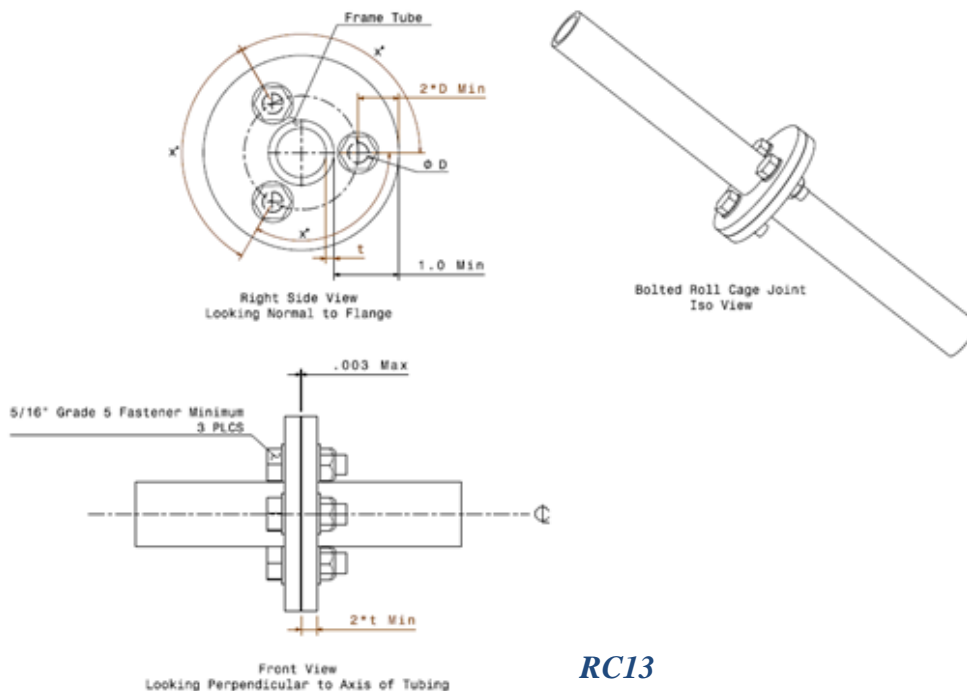

RC13

B8.6 Drilled Frame Members

B8.6.1 Sleeved Joints

Frame members which need to be drilled for the purpose of mounting fasteners or routing accessories must be reinforced with a welding sleeve. Sleeves must be designed to fit tightly on the inside of the hole or joint being reinforced. Sleeves must extend beyond the tube on both sides and be welded to the tube all the way around as shown in RC14.

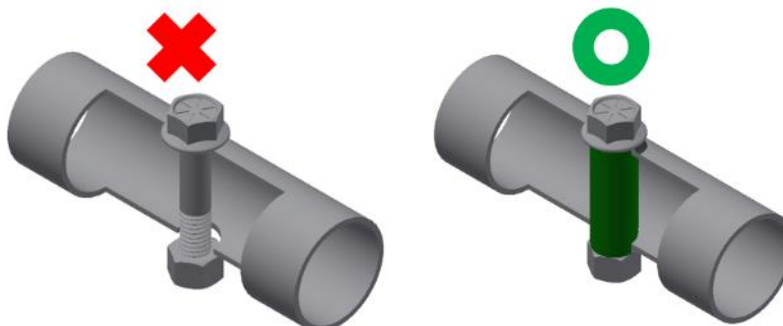

RC14

B8.7 Frame Pre-Check (UPDATED)

B8.7.1 Documents required for submittal

Roll Cage Specification Sheet & frame material documentation (invoices, certifications, calculations, etc.)
(Frame diagram/drawings are not required.)

B8.7.2 Documents submittal process

- Download the form and template from bajasae.net download section (NOTE: All files that are uploaded must be in a .PDF format)
- Upload the Frame Documentation Package (max size 5MB)
 - Roll Cage Specification Sheet
 - Frame Material Documentation
 - Invoice of roll cage material
 - Material Test of Certification
 - Any Required Calculation per rule B8.3.12
 - A diagram highlighting what parts of the frame were outsourced or professionally fabricated

B8.7.3: Pre Frame check Document Response Process: (updated)

Documents will be reviewed by the National Technical Inspectors on a first come first serve basis. Typical review period will be 30 days after submittal. **After review, feedback will be given to teams. If the submission is rejected by the National Technical Inspectors, the team must correct the error noted in the rejection and continue to resubmit the Frame Documentation Package, until they receive a Pass Judgment.** It is the responsibility of teams to submit complete documents by the appropriate deadlines. If teams have additional questions they will need to use other resources to find the answers or wait until competition.

Note: If your initial Frame Check Document is received more than five (5) days late it will be classified as “Not Submitted” and your team will be removed (cancelled) from the event. Documents do not need to receive a Pass Judgment in order to satisfy this requirement.

ARTICLE 9: COCKPIT AND THROTTLE

B9.1 Design Objective

The cockpit must be designed to (1) protect the driver and (2) permit easy driver exit in an emergency.

B9.2 Driver Exit Time

All drivers must be able to exit on either side of the vehicle within five (5) seconds. Exit time begins with the driver in the fully seated position, hands in driving position on the connected steering wheel, and wearing the required driver equipment. Exit time will stop when the driver has both feet on the ground. Driver’s exit time must be demonstrated by a team driver, as selected at technical inspection.

B9.3 Firewall

There must be a firewall between the cockpit and the engine and fuel tank compartment. It must cover the area between the lower and upper lateral cross members (LCA and LCB) on the Rear Roll Hoop.

B9.4 The firewall must be metal, at least 0.50 mm (0.020 in.) Thick, and must completely separate the engine compartment and fuel tank from the cockpit.

B9.5 Multiple panels may be used to form the firewall but there must be no gaps between the joints. Cutouts in the firewall are allowed, but they must have grommets or boots that prevent large amounts of fuel from getting into the cockpit.

B9.6 Front or Mid-engine vehicles

If the mounting points of the engine are completely in front of the RRH, then a firewall is not required to cover the area between the RRH lateral cross members. Instead, the firewall must meet the following standards:

- (A) Fuel tank must be in a sealed container that prevents fuel from leaking in the event of fuel tank failure.

- (B) Splash shields must prevent fuel from being poured anywhere in the cockpit area during fueling. (See rule B12.6 “Spill Prevention”)
- (C) Engine must be completely enclosed and protect the driver in the event of an engine failure. Shielding must meet guarding requirements. This shielding must be made of metal. (See rule B15.1 “Powertrain Guards”).
- (D) All engine compartment venting must be directed away from driver area.
- (E) Driver must be able to still egress from either side of the vehicle.
- (F) The exhaust must not exit towards the driver and must be shielded.
- (G) There must be a place to mount the Technical Inspection sticker (30cm x 30cm or 12 in x 12 in) on the RRH. It must be located on the driver’s right side above the shoulders in easy view of track workers.

Note: Engine enclosures must prevent fuel from spilling onto driver area during any vehicle upset.

B9.7 Body Panels

The cockpit must be fitted with body panels that cover the area between the lower frame side member and the side impact member. No gaps can exist that are larger than 6.35 mm (0.25 in). These panels must be made of plastic, fiberglass, metal or similar material. They must be designed to prevent debris and foreign object intrusion into the driver compartment. The panels must be mounted securely to the frame using sound engineering practices (zip ties and Velcro are not acceptable).

B9.8 Belly Pan

The cockpit must be fitted with a belly pan over the entire length of the cockpit, so that the driver cannot contact the ground and is protected from debris while seated normally. Belly pan material must be metal, fiberglass, plastic, or similar material. They must be designed to prevent debris and foreign object intrusion into the driver compartment. Expanded metal, fabric, or perforated panels are not allowed.

B9.9 Leg and Foot Shielding

All steering or suspension links exposed in the cockpit must be shielded with metal. The shielding must prevent the driver’s legs and feet from coming in contact, or becoming entangled during operation or a failure. A Universal joint in the steering system near the driver’s feet shall be shielded or booted such that the driver may not become entangled in the joint.

B9.10 Fire Extinguisher –Equipment, Size and Location and required mount

- Each team must have two identical fire extinguishers with a minimum UL rating of 5 B-C.
- The vehicle shall have one fire extinguisher installed and the second extinguisher serves as a spare.
- All fire extinguishers must be equipped with a manufacturer installed dial pressure gauge. The gauge must be readable.
- The only acceptable fire extinguisher mount is the Drake FIREX-MNT-DOR, <http://www.drakeautomotivegroup.com/Store/Product/FIREX-MNT-DOR.aspx?wid=141>
- We recommend that each team have a backup mount in the event of damage or loss during the event

B9.11 Fire Extinguisher – Vehicle Mounting and Placement (Updated)

- The required mount must be securely fastened to the Rear Roll Hoop (RRH) with metal tab(s) that are a minimum of 0.125 inch thick.
- -The extinguisher shall be mounted in the cockpit below the driver’s head, with the top half above the side impact member on the right side of the firewall and be easily accessible by course workers.
- -Radial clearance around the pull-knob shall not be less than 2.5 inches, as depicted by the highlighted area in Figure 7. It is understood the area aft of the pull knob will be less due to the mount design. Note: radial clearance means unoccupied space between the edge of the pull knob and the nearest obstruction. This measurement is not made to the center of the pull knob.
- Mounting hardware shall be flat socket cap screws, with a countersink angle and head diameter to match the DRAKE mount and meet the requirements of B14.1.

- Hose clamps attaching the extinguisher to the mount shall be aligned such that they will not injure a track worker reaching for the pull tab, or snag on the clothing of a driver egressing from the vehicle.



Figure 7

B9.12 Throttle Controls

Only mechanical foot operated throttle controls are allowed. A wide-open throttle stop must be mounted at the pedal. Controls must be designed to return to idle-stop in the event of a failure. The throttle cable must be covered (sheathed) between its forward mounting point and the firewall. Foot pedals must be positioned so as to avoid foot entrapment in any position.

Your throttle must remain set at the as-passed condition, so return to idle and ensuring full throttle is achievable must be set prior to arriving at tech.

B9.13 Throttle Extensions

Mechanical extensions such as thick pads or blocks may not be attached to control surfaces or the driver's feet.

ARTICLE 10: DRIVER RESTRAINT AND SEATING

B10.1 Minimum Five Strap System Required

A safety harness system of at least 5 points must be worn by all drivers. The lap belt and shoulder belts must be approximately 76 mm (3 in.) wide. The fifth ("anti-submarine") belt must be worn between the legs to prevent the lap belt from riding up along the driver's torso. The safety harness must be installed using good engineering practice. The safety harness must be worn snugly (one finger width maximum gap).

As an alternative to a five-point harness, a six or seven-point safety harnesses may be used if properly installed and worn.

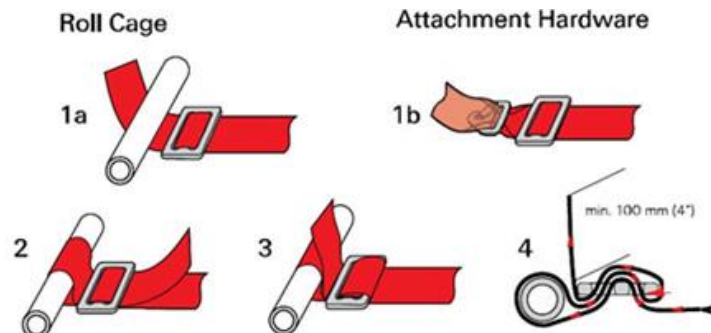

Proper Wrapping of a Shoulder Belt

http://www.gforce.com/pdf/Harness_Install_Info.pdf

NOTE: If the belts do not have enough adjustment capacity, the vehicle may not be operated.

B10.1.1 Release Mechanism

All belts must join with a single metal-to-metal quick release lever type buckle. No camlock systems are allowed.

B10.1.2 Safety Harness Expiration

The material of all straps must be of Nylon or Dacron polyester and in new or perfect condition. All driver restraint systems must meet either SFI Specification 16.5/16.1, or FIA specification 8853/98. The belts must bear the appropriate dated labels, and on Jan 1st of the competition year be no more than three years old.

B10.2 Shoulder Harness

The shoulder harness must be of the over-the-shoulder type. Only separate shoulder straps are permitted (i.e. “Y”-type shoulder straps are not allowed).

B10.2.1 Vertical Location

Shoulder belt mounts must be no higher than vertically level with each driver’s shoulders, and no lower than 102 mm (4 in.) vertically below each driver’s shoulders. Shoulder belt mounts must be entirely on the cockpit side of the firewall, and be protected by the firewall. The shoulder belts must run directly from their mountings to the driver’s shoulders, without redirection by any part of the vehicle or its equipment (Figure 8B).

B10.2.2 Lateral Spacing

The shoulder harness mounting points must be between 178 mm (7 in) and 229 mm (9 in) apart (Figure 8A).

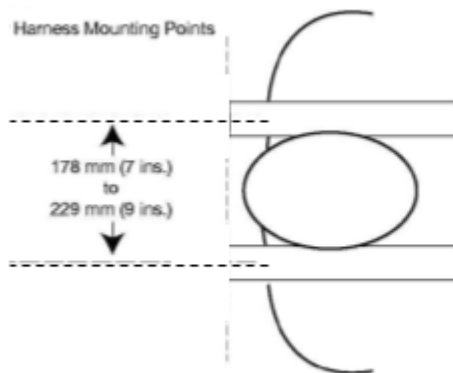

Figure 8A



Figure 8B

B10.2.3 Harness Attachment Points

The shoulder belts must be looped around a **straight** horizontal tube welded within the RRH plane that meets the Roll Cage Secondary Member requirements of B8.3.1. Lateral motion of the belts along their mounting tube must be restrained by something other than the firewall (Figure 9A). The firewall must protect the entire shoulder belt. The firewall may be pocketed to facilitate this, as long as no open gaps result. Figure 9B shows an unacceptable mount because the mounting tube is not in plane with RRH.



Figure 9A



Figure 9B

10.3 Lap Belts

B10.3.1 The lap belt must pass around the driver's pelvic area below the Anterior Superior Iliac Spines (the hip bones – Figure 10A). The lap belt must not be worn over the driver's intestines or abdomen. In side view, the lap belt must be at an angle of between 45 degrees and 65 degrees to the horizontal (Figure 10A). This means that the centerline of the lap belt at the seat bottom should be approximately 76 mm (3 in.) forward of the bottom of the seat back. The lap belt halves must run directly from the driver's hips to their mounting points without redirection by any part of the vehicle or its equipment (including the seat). The lap belt halves must be mounted to frame tabs using the bracket supplied with the safety harness

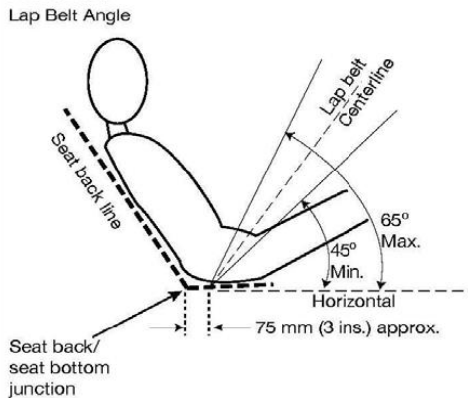

Figure 10A

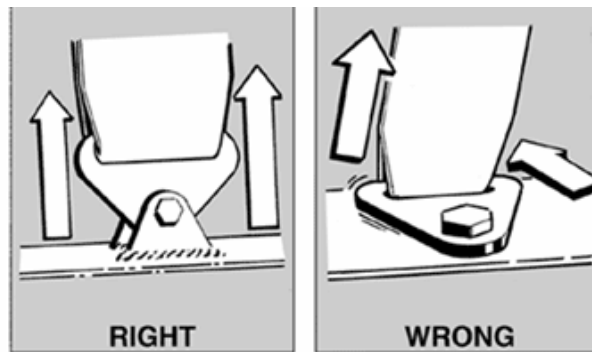

Figure 10B

The lap belts must freely pivot to fit drivers of differing statures correctly. The lap belt bracket must not be loaded in bending (see Figure 10B above). Eye bolt lap belt connections are specifically prohibited (see Figure 11).



Figure 11

B10.3.2 Lap Belt Mounting

The frame tabs which accept the lap belt mounting brackets must meet the following requirements:

- 1) The lap belt tabs and anti-submarine belt tabs must be mounted in double-shear. Tab material must be no less than 2.3 mm (0.090 in.) thick.
- 2) Tabs must be attached to the frame with no less than 38 mm (1.5 in.) of weld length per tab.
- 3) Tabs must have no less than 6.4 mm (0.25 in.) of material width from the edge of the mounting hole to the outside edge of the tab.
- 4) Mounting bracket must pivot freely (i.e., not bear on screw threads, or be pinched by the tab).
- 5) Tab mounting must be stiff (i.e., not noticeably deform when pulled).
- 6) 6 and 7 point mountings should meet manufactures' requirements.
- 7) No cutouts are allowed on the seatbelt tab other than the hole for the lap belt mounting bolt.
- 8) All hardware in the driver restraint system shall match the nominal diameter of the mounting holes in the harness side tabs. The mounting tabs to the chassis must have holes of the same size. For example, a seat belt harness tab with a 0.5-inch hole may only use a bolt with a 0.5" diameter and be mounted to a frame tab with a hole of 0.5" diameter.

B10.4 Anti-Submarine Belts

B10.4.1 Mounting

Anti-submarine belts must be mounted aft of a vertical plane that intersects the leading edge of the seat, and must be mounted a minimum of 254 mm (10 in.) forward of the lap belt mounting points. The anti-submarine belt may be mounted either to a frame tab, or wrapped around a frame member.

B10.4.1.1 If mounted to a frame tab, then the tab must conform to the rules for the lap belt tabs above.

B10.4.1.2 If wrapped around a frame member, then:

1. The mounting tube must have features designed to limit lateral belt movement along the tube to less than 1 inch.
2. The anti-sub mount must be directly connected to a LC, it cannot be "cantilevered" off another tube or otherwise create a torque from an offset mounting point

B10.4.2 Redirection

Redirection of the anti-submarine belt by a one rigid frame or seat member is allowed. Redirected belt webbing must not contain a bend of more than 30 degrees (Figure 12). The redirecting member must be designed to prevent chaffing

of the belt webbing by use of edge treatment to sharp edges with molding, plastic, heavy duty tape or other similar material.

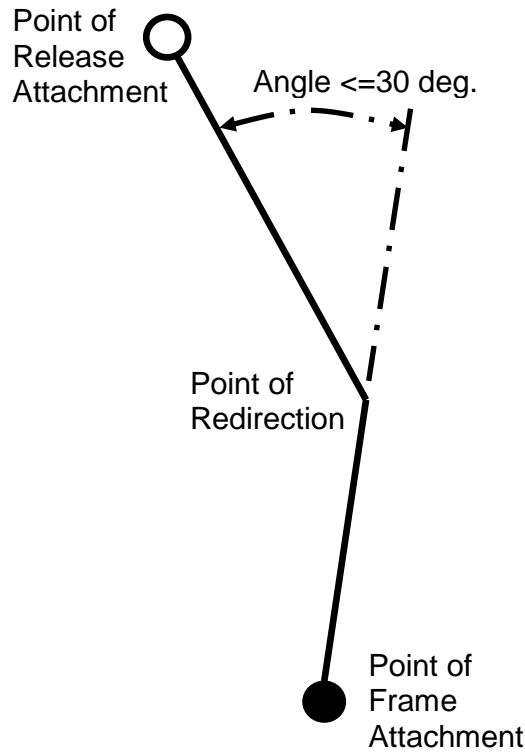

Figure 12

B10.4.3 Six and Seven Point Harnesses

6-point and 7-point harness mountings must meet the requirements in items 1, 6, & 7 (both mounts), and the mounting points must be laterally spaced by at least 203 mm (8 in.).

B10.5 Arm Restraints

B10.5.1 In the event of a rollover, the driver's arms must be kept within the limits of the roll cage space (B8.2) by use of arm restraints. Arm restraints must be securely fastened to the driver restraint system. Only commercially available arm restraints meeting SFI 3.3 are allowed. The arm restraints must independently connect to the safety belts.



Figure 13

B10.5.2 Arm Restraint – Installation

Arm restraints must be installed such that the driver can release them and exit the vehicle unassisted, regardless of the vehicle's position. The arm restraint must be worn by the driver on the forearm just below the elbow. The driver must be able to reach the cockpit kill switch and steering wheel, but not allow their arms to exit the cockpit.

B10.5.3 Arm Restraint – Expiration

The belts must be in overall good condition and show no signs of wear, no cuts chaffing or wear. The belts must bear the appropriate dated labels, and on January 1st of the competition year be no more than three years old.

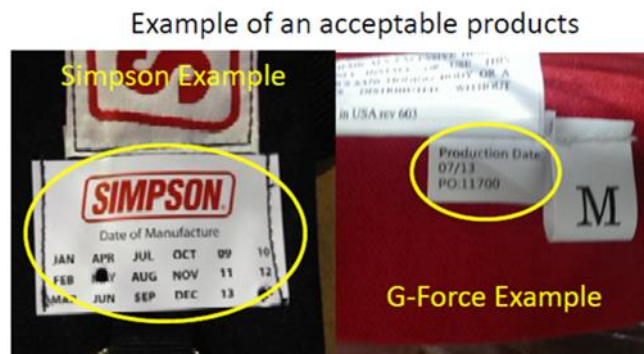

Figure 14

NOTE: Manufactures are **required** to ensure they have labeled the belts with a date of manufacturing.

B10.6 Installations – General

All installations must prevent accidental unfastening from a direct pull, rollover or slide along the side.

B10.7 Seats

The seat shall work in concert with the safety harness to secure the driver within the envelope of the roll cage. Seats may be of conventional or suspension (sling) design. All seats shall be designed for the upright seating position. The upright seating position is defined by the angle of the driver's back to a horizontal line. The back angle for an upright seating position is more than 65 degrees. As a reference, a completely upright driver will have a back angle of 90 degrees.

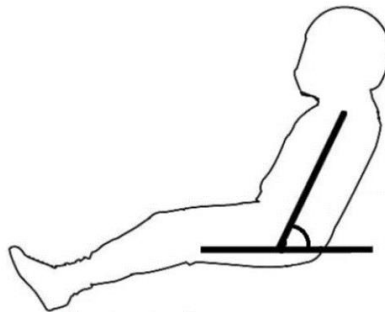

Figure 15

B10.7.1 Seat Construction

Conventional seats shall be generally rigid and be of metal or composite construction. Conventional seats may also have a removable seat cover and foam padding. Suspension seats shall be constructed of resilient, durable, woven materials. Stitching shall be neat and sufficient to effectively join all seat parts and safely direct forces from the driver to the vehicle frame. Seats may be purchased from a manufacturer or constructed in-house.

B10.7.2 Seat Design

Seats shall be designed to have at least two generally planar surfaces when the driver is seated in the vehicle. The seat back plane shall be inclined between 65 and 90 degrees from horizontal (as viewed from the side). The seat bottom plane shall be underneath the driver and be horizontal or generally sloped such that the leading edge of the seat bottom plane is level with or higher than the intersection with the back plane. Seats may also include material oriented vertically along the sides of the seat bottom plane and the seat back plane designed to assist in laterally restraining the driver.

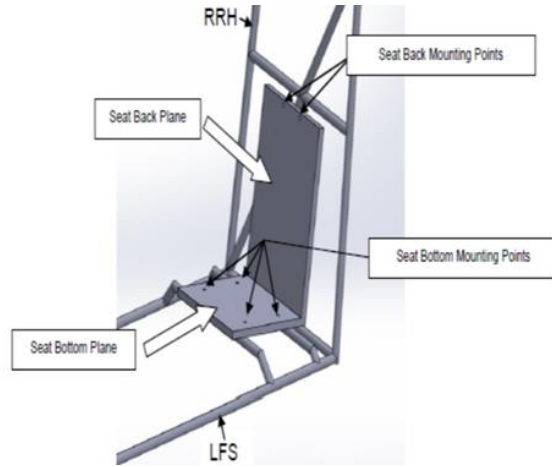

Figure 16

B10.7.3 Seat Mounting

All seats shall have no less than six total mounting points to the vehicle frame. Seats shall have no less than four mounting points from the seat bottom plane and no less than two mounting points from the seat back plane. The seat bottom plane and seat back plane mounting points shall be generally symmetrical about the longitudinal center line of the seat itself or the vehicle. Seat back plane mounting points shall be at or near the plane of the RRH. ALL seat mounting points shall attach to the LFS, USM, RRH or other tubes having met the requirements of secondary frame members. Each seat bottom mount shall be designed to evenly distribute vertical load. Any tabs utilized in mounting the seat shall be a minimum thickness of 0.090 inches and have at least 1.5 inches of weld length per tab. Mounting Tabs shall not visibly deform when a load is applied. The average distance from the tab hole to the main tab weld line shall not exceed 1.0 inches. Any tube used to mount the seat with radial holes drilled in the tube shall be sleeved and reinforced per rule B8.6

B10.7.4 Seat Mounting (Suspension Seats)

Suspension seats shall be mounted in a manner to meet the requirements of 10.7.3. Suspension seat mounting points from the seat back plane attaching to the vehicle RHO shall not be more than 4 inches forward of the plane of the RRH along the RHO tube.

Suspension Seat bottom plane mounting points attached to the SIM shall be within 2 in. of a frame node or have bracing to route forces to frame nodes. Nodes with suspension mounting points that connect the SIM and LFS are acceptable. Figure 17 depicts the bracing required. Bracing shall be steel tubing not less than 0.5 in. in diameter and 0.049 in. wall thickness.

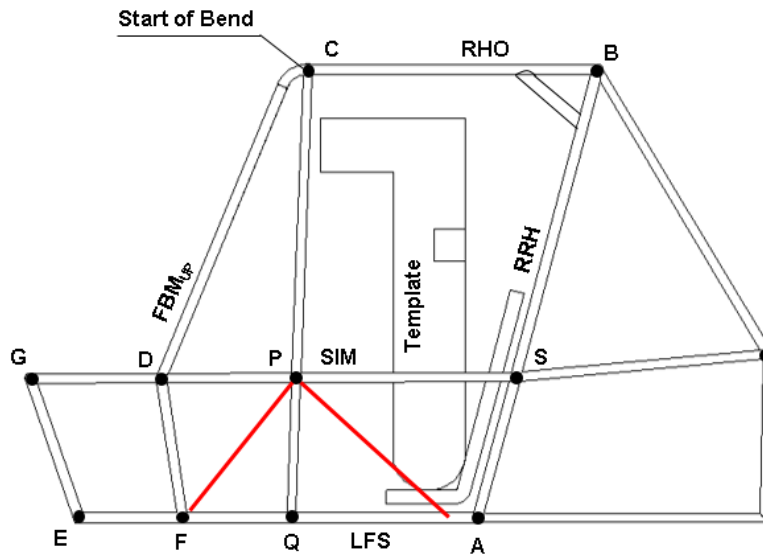

Figure 17

B10.8 Head Restraint

A head restraint must be provided to limit rearward motion of the driver's head. The head restraint must be mechanically fastened (NO Velcro or adhesive) to the vehicle, preferably the vehicle frame. Head restraints may also be mechanically fastened or integral to the driver's seat.

ARTICLE 11: BRAKING SYSTEM

B11.1 Foot Brake

The vehicle must have hydraulic braking system that acts on all wheels and is operated by a single foot pedal. The pedal must directly actuate the master cylinder through a rigid link (i.e., cables are not allowed). The brake system must be capable of locking ALL FOUR wheels, both in a static condition as well as from speed on pavement AND on unpaved surfaces.

B11.2 Independent Brake Circuits

The braking system must be segregated into at least two (2) independent hydraulic circuits such that in case of a leak or failure at any point in the system, effective braking power shall be maintained on at least two wheels. Each hydraulic circuit must have its own fluid reserve either through separate reservoirs or by the use of a dammed, OEM-style reservoir.

B11.3 Brake(s) Location

The brake(s) on the driven axle must operate through the final drive. Inboard braking through universal joints is permitted.

Braking on a jackshaft through an intermediate reduction stage is prohibited

B11.4 Cutting Brakes

Hand or feet operated "cutting brakes" are permitted provided the section (B11.1) on "foot brakes" is also satisfied. A primary brake must be able to lock all four wheels with a single foot. If using two separate pedals to lock 2 wheels apiece; the pedals must be close enough to use one foot to lock all four wheels. No brake, including cutting brakes, may operate without lighting the brake light.

B11.5 Brake Lines (UPDATED)

- All brake lines must be securely mounted and not fall below any portion of the vehicle (frame, swing arm, A-arms, etc.)
- Ensure they do not rub on any sharp edges.
- Avoid being pinched by suspension parts
- Have full range of motion in steering and suspension motion.
- Never loaded in tension at the extremes of the steering angle.
- Plastic brake lines are strictly prohibited.

ARTICLE 12: FUEL SYSTEM AND FUEL (UPDATED)

B12.1 Fuel System Location

The entire fuel system, including splash shield, drip pan, and engine (excluding intake air hoses) must be located within the envelope of the vehicle's roll cage (members defined in B8.3.1, and any extra primary or secondary members). The fuel tank mountings must be designed to resist shaking loose. All fuel tank mounting points shall be used.

Fasteners must meet rule B14

Fuel tanks must be mounted directly to the roll cage directly, using at a minimum secondary member. Cantilever mounts are prohibited. The tabs that mount the fuel tank must be welded to the roll cage secondary members and hold the tank rigid. Tabs must be less than 2" in length from the mounting hole to the outside of the secondary member it is welded to.

Example of an acceptable design

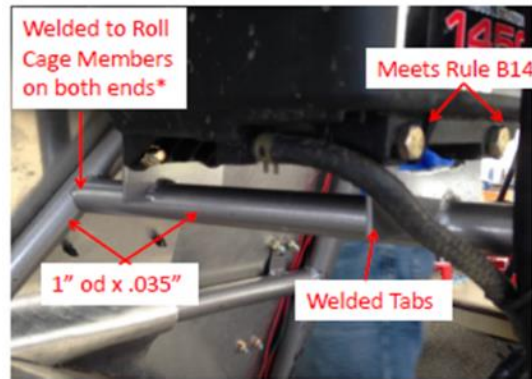

* Member can be removable if it meets rule B8.5.1

Figure 18

B12.2 Removable Fuel Tank

- B12.2.1** Removable fuel tanks are allowed for the purpose of rapid and spill-free refueling. Removable fuel tanks must be equipped with a quick disconnect coupling on the fuel line. The tank must mount by sliding onto two dowel pins (Figure 19A) which fit tightly into the two holes in the bottom of the Briggs and Stratton fuel tank. Removable tank mountings **must** also meet the following guidelines:
- B12.2.2** The mounting of the tank box must be mounted to secondary members using a minimum of 4 points that are at a similar spacing as the fuel tank OEM mounts.
- B12.2.3** The fuel tank must be mounted in a container that has two dowel pins located in the center that the fuel tank will securely slide onto (Figure 19A).
- B12.2.4** The cover of the container when closed must contact the gas cap or tank to prevent the tank from moving vertically on the dowel pins. The container/cover must be made out of metal and mounted using sound engineer practices (Figure 19B). Latch design shall be rubber draw latch or over-center latches, such that the latch is easily actuated by track workers with gloves on.

One of the following quick disconnect couplings must be used (Figure 19C). The female fitting must be installed on the fuel tank side.

http://www.colder.com/Downloads/IndCat_REV_FINAL.pdf

- Female coupling, Colder P/N: PLCD170-04-V (P. 20) or Briggs & Stratton P/N: 189117GS
- Male coupling, Colder P/N: PLCD220-04-V (P. 21) or Briggs & Stratton P/N: 192695GS

<http://www.jiffytite.com/motorsports.cfm?sublevel=398&subpage=397>

- Socket with Hose Barb Adapter P/N 21504
- Plug with Hose Barb Adapter P/N 22504

Note: Removable tanks still must meet the splash shield and spill prevention rules. The cost for two tanks, two check valves, and all couplings must be included in the engine section of the cost report.



Figure 19A



Figure 19B



Figure 19C

B12.3 Fuel Tank (UPDATED)

B12.3.1 Only a single fuel tank is permitted on the vehicle. Fuel tanks are restricted to [Briggs and Stratton part number 799863](#) tank. (Note: Part Number 799863 is the tank used on the Model 20 engine for 2016 and prior racing years.)

No holes are allowed in the tank even if they have been repaired.

Fuel pumps may not be used.

The retail price of the pn.799863 tank must be included in the cost report.

NOTE: For the 2017 season, teams can only use the old Model 20 style tank, mounted remotely.

B12.3.2 A standard Briggs and Stratton gas cap with a built in check valve (Part # B4325GS) is required. The retail price must be included in the cost report.

B12.4 Fuel Lines

B12.4.1 All fuel lines must be located away from sharp edges, hot engine components and be protected from chafing. Grommeting is required where the lines pass through any member of the vehicle. Fuel lines are not allowed in the cockpit.

B12.4.2 All lines must be SAE rated fuel lines and attached securely to prevent minimum line movement using sound engineering practices. Lines must be no larger than the stock lines supplied with the engine (i.e. 12.7 mm (0.5 in.) outer diameter and 6.3 mm (0.25 in.) inner diameter). The Briggs and Stratton fuel line is 1/4" SAE J30R14 or 30R7-RP. Bulk fuel line can be ordered through Briggs and Stratton and is part number 395051R.

B12.4.3 If a fuel filter is used, it must be a Briggs and Stratton stock filter.

B12.5 Spill Prevention

The fuel tank must be mounted so that if fuel spills it will not come in contact with the driver or the engine. Complying with this rule requires a drip pan that is at least 203.2 mm (8 in) in diameter (or equivalent area) and has sides at least 38 mm (1.5 in) high above the top edge of the tank.

B12.5.1 Drip Pan Mounting

Drip pans must be mounted using sound engineering practices. A drip pan mounting comprised only of fastening to the fuel tank filler neck is insufficient, and is not allowed. Drip pans must be graded or inclined such that all spilled fuel drains from the drip pan – fuel must not pool anywhere in the pan.

B12.5.2 Drip Pan Drain

Fuel must drain from the drip pan through a drain line composed of pipe or tubing that carries fuel to the bottom of the vehicle and releases under the vehicle. Tubing and fittings shall be rated for fuel use, and shall have appropriate fuel rated markings. Fuel may not be released onto the belly pan, or any other part of the vehicle. The drain line shall be robust and be mechanically fastened to the drip pan with a threaded connection or a hose barb and hose clamp, or a combination of the two. Adhesive connections are specifically prohibited. All materials in the drip pan system shall be rated for fuel or fuel resistant.

The nominal minimum inside diameter for the drain hose shall be 12.7 mm (.5 in.). Matching fittings shall have a minimum inside diameter of 9.5mm (.375 in.).

B12.5.3 Drain Line Material

Drains lines must be made of either fuel line material, or other pipe or tubing which is not weakened or dissolved by fuel. The drain line connection to the drip pan must be sealed and robust.

B12.6 Splash Shields (new)

Splash shields are required to prevent fuel from accidentally being poured directly on the engine or exhaust while refueling or preparing to refuel the vehicle.

Note: Splash shields are required with either the stock tank with a drip pan, or the removable tank.

B12.6.1

The splash shields shall be mounted such that they are effective at all times, and are not adjustable by the driver or team members. Splash shields shall be of resilient mounting and protect against fuel being poured on the hot surfaces of the engine.

Note: Figure 20 are examples of approved spill/splash shields:



Figure 20

Note Figure 21 The following spill/splash shield is NOT acceptable:



Figure 21

B12.7 Fuel

The only fuels permitted in the vehicles are grades of automotive gasoline consisting of hydrocarbon compounds. The fuel may contain anti-oxidants, metal deactivators or corrosion inhibitors.

“Lead alkyl compounds such as tetra-ethyl lead” are prohibited!

B12.7.1 The addition of nitrogen bearing additives, or additives designed to liberate oxygen is strictly prohibited.

B12.7.2 Specific gravity of the fuel may not exceed 0.75 for leaded gasoline or 0.80 for unleaded gasoline when measured at 60 degrees Fahrenheit.

B12.8 Fuel Containers

All fuel must be transported in, and put into vehicle fuel tanks, from approved, unmodified containers. Approved, unmodified containers shall:

- 1) Have a volume of 1.5 gallons or less for fueling vehicles during endurance event.
- 2) Have a volume of 5 gallons or less for all other capabilities.
- 3) Be equipped with an original cap to prevent spills when not in use.
- 4) Be labeled with school name and car number.

Teams are required to bring all fuel to the fueling zone during the endurance event, see rule D5.8.

ARTICLE 14: FASTENERS

B14.1 Fasteners in the following systems must meet the rules in Article 14.

- Driver Restraint
- Fuel System Mounting
- Fire Extinguisher Mounting
- Kill Switch Mounting

B14.2 Fasteners Captive

Fasteners must be made captive through the use of NYLON locknuts, cotted nuts or safety wired bolts (in blind applications). Lock washers or thread sealants do not meet this requirement.

B14.3 Fastener Grade Requirements

Threaded fasteners utilized must meet or exceed either, SAE Grade 5, Metric Grade 8.8 and/or AN/MS specifications. See Figure 22.

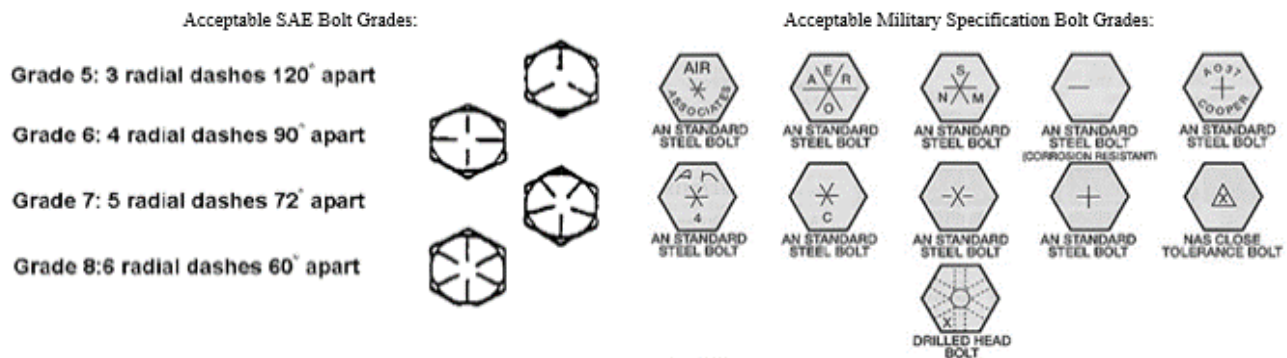

Figure 22

B14.4 Thread Exposure

Threaded fasteners used must have at least two (2) threads showing past the nut.

B14.5 Proper documentations is supplied, which must include a purchase receipt, and manufacturer’s documentation indicating bolt strength equivalent to the above.

B14.6 Unmarked Fasteners / Shop Manufactured Fasteners

Any threaded fastener (threaded rod, eye bolts, titanium bolts, etc.) That is unmarked, or does not have any markings as listed, must be documented by either:

- (A) A purchase receipt and manufacturer’s documentation indicating that the fastener meets or exceeds Grade 5 standards for that size.

OR

- (B) Equivalency calculations with a purchase receipt or test data showing that the fastener exceeds the strength for a Grade 5 fastener of the same size.

B14.7 Modified Fasteners

Fasteners which have been modified in any way other than: (1) drilling for safety wire or (2) shortening of the shank (threads) shall be subject to all requirements set forth.

B15.1 Powertrain Guards

All rotating parts such as chains, sprockets, primary CVT pulleys, and belts that rotate at the rate of the drive axle(s) or faster, must be shielded to prevent injury to the driver or bystanders should the component fly apart due to centrifugal force. These guards/shields must extend around the periphery of the rotating components and must be wider than the rotating part they are protecting. NOTE: This rules includes the entire periphery of the primary CVT pulley, not just the belt width.

Holes and/or vents in the portion of the powertrain guard surrounding the rotating components are acceptable provided that in the event of a powertrain failure, no parts can escape. No direct path shall exist tangent to any rotating components.

They must be mounted with sound engineering practice, in order to resist vibration.

Required Materials:

Made of at least AISI 1010 strength steel at least 1.5 mm (0.06 in) thick - 16 Gauge is allowed.

-Or-

Made of at least 6061-T6 strength aluminum at least 3.0 mm (0.12 in) thick

B15.2 Finger Guards

Rotating parts must also be guarded all around, in addition to the guard around the periphery. All around guarding (finger guards) must prevent small, searching fingers from getting caught in any rotating part. **Non rigid, fabric coverings such as "Frogskin", Ceconite, and neoprene are unacceptable for use as finger guards.** A complete cover around the engine and drivetrain is an acceptable shield.

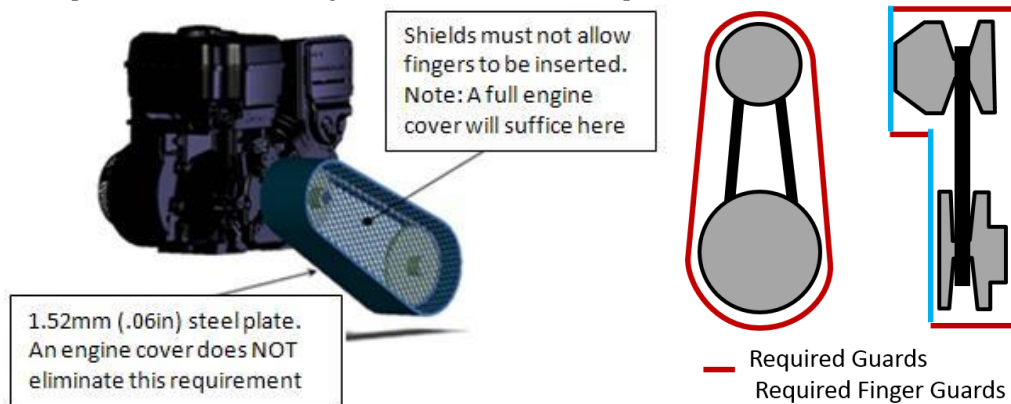

Figure 23

B15.3 Factory Stock Guards

Factory stock guards must meet the requirements in B15.1. OEM Polaris CVT covers that are **not modified** are exempt to rule B15.1. OEM Polaris CVT covers must meet the requirements of B15.2 in way of the vent.

ARTICLE 16: DRIVER EQUIPMENT (Updated)

B16.1 Helmet, Neck Support/Collar & Goggles

All drivers must wear a well-fitting Motocross style helmet with an integrated (one-piece composite shell) chin/face guard and a rating of:

Snell M or SA meeting the latest or immediately preceding standard (e.g. In 2017, the acceptable ratings would be M2015 or M2010 but not older ones)

OR

British Standards Institution BS 6658-85 types A or A/FR.

Goggles must incorporate the use of tear-offs or roll-off systems.



Figure 24

WARNING: Some Motocross helmets have extended chin guards that will not contact the required neck collars when the head is flexed forward. This combination of helmet/collar system is prohibited. Any non-specification helmets will be confiscated until after the competition. This rule has no exceptions and it will be strictly enforced. Helmets certified to other rating systems may not be worn.

B16.1.1 Neck Support/Collar

All drivers must wear a neck support/collar. The neck support must be a full circle (360°) and SFI 3.3 rated. Horseshoe collars are not allowed (see figure). Simpson, RCI, GForce, Deist or Leaf Racing Products supply neck collars that meet this requirement.

The support/collar must be in overall good condition and show no signs of wear, no cuts chaffing or wear. The support/collar must bear the appropriate dated labels, and on Jan 1st of the competition year be no more than three years old.

NOTE: Manufactures are required to ensure they have labeled the support/collar with a date of manufacturing.

Example of an acceptable products

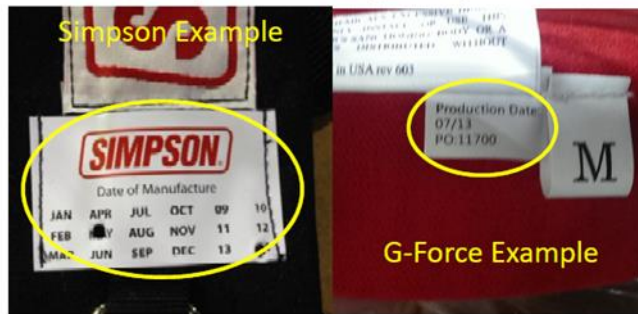

Figure 25



Neck Support Permitted



Neck Support Not Permitted

Figure 26

B16.2 Clothing

Drivers must wear long pants (cotton/Nomex), socks, shoes, gloves, and a long sleeved fire resistant upper garment.

B16.2.1 Upper Garment

The upper garment must have a factory label showing that it is SFI rated, FIA rated or fire resistant.

B16.2.2 Synthetic Material – Prohibited

Jerseys, gloves, socks or other garments made from nylon or any other synthetic material which will melt when exposed to high heat, are expressly prohibited

PART C: DYNAMIC EVENTS-STATIC EVENTS – (U.S & CANADIAN EVENTS)

ARTICLE 1: SCORING

SCORE SUMMARY-STATIC EVENTS – 300 points	Kansas	California	Illinois
Design Evaluation	150	150	150
Cost Report	15	15	15
Prototype Cost	85	85	85
Sales Presentation (for all events)	50	50	50
DYNAMIC EVENTS – 700 points			
Acceleration	75	75	75
Hill Climb or Traction	75	75	75
Land Maneuverability	75	75	75
Suspension	75	75	-
Rock Crawl	-	-	75
Endurance	400	400	400
TOTAL POINTS	1000	1000	1000

ARTICLE 2: TECHNICAL INSPECTION

C2.2 Technical Inspection – Pass/Fail

All Baja SAE vehicles must pass a technical inspection before they are permitted to operate under power.

C2.2.1 The inspection will determine if the vehicle satisfies the requirements and restrictions of the Baja SAE rules.

C2.2.2 If vehicles are not ready for technical inspection when they arrive at the inspection site, they will be sent away.

C2.2.3 Any vehicle may be re-inspected at any time during the competition and correction of any non-compliance will be required.

C2.3 Technical Inspection

Technical inspection will consist of four (4) separate parts as follows

C2.3.1 Engine inspection and governor setting- Governor Setting Check

Briggs & Stratton Technical Representatives will set the governors of all vehicles. Vehicles must be presented for governor setting with the engine output shaft bare, the drivetrain disconnected and the throttle cable disconnected from the engine and working kill switches. Each vehicle engine must be inspected by Briggs and Stratton technical staff that will:

- (1) Confirm its compliance with the rules and
- (2) Set the governor to the specified rpm. (3800)

- The governor check (with entire vehicle) must be passed first (Part 1), before a team may apply for Part 2 (Tech) or Part 3 (Brake) Check.

C2.3.2 Technical Inspection

Each vehicle will be inspected to determine if it complies with the requirements and restrictions of the Baja SAE rules. This inspection will include an examination of the driver's equipment including helmet and arm restraints, a test of driver exit time and to ensure that all drivers meet the requirements of the rules. Each team **must** bring the following items to inspection.

- (A) **Frame Material Documentation:** Receipts documenting the materials purchased, or otherwise acquired, and used to build the frame.
- (B) **Roll Cage Specification Sheet:** A completed copy of the Roll Cage Specification Sheet
- (C) **Technical Inspection Sheet:** A properly completed Technical Inspection Sheet

<http://students.sae.org/competitions/bajasae/rules/>

- (D) **Drivetrain Check Sheet:** A properly completed Drivetrain Check Sheet
- (E) **Drivers Present:** All drivers must be present at technical inspection with a valid license.
- (F) Technical inspection must be passed before a team may apply for kill switch and dynamic braking inspection.

C2.3.3 Kill switch and dynamic brake testing

Both the external and cockpit kill switches will be tested for functionality. If both switches pass the test, then the vehicle will be dynamically brake tested. Each vehicle must demonstrate its ability to lock all four wheels and come to rest in an approximately straight line after acceleration run specified by the inspectors. If a vehicle fails to pass any part of the inspection, it must be corrected/modified and brought into compliance with the rules before it is permitted to operate.

C2.4 Inspection Stickers

C2.4.1 A multi-part inspection sticker will be issued in sections to each vehicle as each of the three parts of technical inspection is completed. The inspectors will place the inspection sticker on the right side of the firewall above the driver's shoulder. The inspection sticker must remain on the vehicle throughout the competition. Vehicles without all parts of the inspection sticker may not be operated under power.

C2.4.2 Any or all parts of the inspection sticker may be removed from any vehicle that has been damaged or which is reasonably believed may not comply with the rules.

C2.5 Technical Inspection Sheet – Pre-Inspection Required

C2.5.1 Before bringing their vehicle to technical inspection each team **must**

1. Pre-inspect the vehicle for compliance with the rules,
2. Complete the official technical inspection sheet (available on the Baja SAE® Rules and Important Documents website, <http://students.sae.org/competitions/bajasae/rules/>),
3. Have the completed inspection list signed by the faculty advisor and team captain. Required reading includes for news and important information includes: <http://students.sae.org/cds/bajasae/news>.

C2.5.2 Teams must download the most current version of the technical inspection sheet within two weeks of the competition and thoroughly inspect their vehicle in accordance with the sheet.

C2.5.3 All drivers must be at technical inspection or they will be removed from the list of drivers.

NOTE: Teams presenting Technical Inspection Sheets that are (1) incomplete, (2) inaccurate (i.e. do not correspond to the actual condition of the vehicle) (3) are found to have 4 items not in accordance with the rules, or (4) do not represent a serious effort at pre-inspection will be denied inspection at that time and sent back to the end of the inspection line.

C2.6 “As-approved” Condition

- C2.6.1** Once a vehicle has passed technical inspection its configuration may not be modified. All accessory components such as roofs, wings, bumpers, etc. are considered part of the configuration and must remain on the vehicle at all times.
- C2.6.2** Approved vehicles must remain in “as-approved” condition throughout the competition. Any repairs of a part that is not identical as the broken part must be approved prior to the repair.
- C2.6.3** Non-identical parts not approved will be subject to an appropriate performance penalty.
- C2.6.4** Minor adjustments permitted by the rules and normal vehicle maintenance and tuning are not considered modifications.

ARTICLE 3: ENGINEERING DESIGN EVENT

C3.1 Engineering Design Event Overview and Objective

- C3.1.1** The objective of the engineering design event is to evaluate the engineering effort that went into the design of the vehicle and how the engineering meets the intent of the market, as detailed in the Program Objective A1.1 and the Design Subject A1.2. Students will be judged on the creation of design specifications and the ability to meet those specifications, computer aided drafting, analysis, testing and development, manufacturability, serviceability, system integration and how the vehicle works together as a whole. Each of these parts of the engineering product development cycle will be judged within the following subsystems: Suspension, Steering, Brakes, Drivetrain/Powertrain, Chassis and ergonomics.
- C3.1.2** The vehicle that illustrates the best use of engineering to meet the design goals and the best understanding of the design by the team members will win the design event.

Comment: Teams are reminded that Baja SAE® is an engineering design competition and that in the Engineering Design Event; teams are evaluated on their design. Components and systems that are incorporated into the design as finished items are not evaluated as a student designed unit, but are only assessed on the team’s selection and application of that unit. For example, teams that design and fabricate their own shocks are evaluated on the shock design itself as well as the shock’s application within the suspension system. Teams using commercially available shocks are evaluated only on selection and application within the suspension system.

- C3.1.3** The engineering design event student guide and score sheet can be found at www.bajasae.net/go/downloads.
- C3.1.4** The engineering design event consists of two parts: Design Evaluation and a Design Report that will be used as a part of the design evaluation

C3.2 Design Report – Required Submission

- C3.2.1** Design Report – The design evaluation judging will start with submission, before the event, of a Design Report. The Design Report will be reviewed by the design judges who will ultimately judge the team and vehicle at on-site Design Evaluation.
- C3.2.2** The Design Report must not exceed eight (8) pages, consisting of not more than four (4) pages of text, three (3) pages of drawings (see C3.4, “Vehicle Drawings”) and one (1) optional page containing content to be defined by the team (photo’s, graphs, etc.). All pages must be either 8 ½” x 11” or A4.
- C3.2.3** The Design Report should contain a brief description of the vehicle with a review of your team’s design objectives, vehicle concepts, and a discussion of any important design features. Note or describe the application of analysis and testing techniques (FEA, part/system/vehicle testing, etc.). Evidence of this analysis and back-up data should be brought to the competition and be available, on request, for review by the judges.

C3.3 Design Spec Sheet – Required Submission

C3.3.1 Design Spec Sheet – A completed Baja SAE® Design Spec Sheet must be submitted.

C3.3.2 The Baja SAE® Design Spec Sheet template can be found at www.bajasae.net/go/downloads. Do not alter or re-format the template prior to submission.

C3.3.3 The design judges realize that final design refinements and vehicle development may cause the submitted figures to diverge slightly from those of the completed vehicle. For specifications that are subject to tuning, an anticipated range of values may be appropriate.

C3.3.4 The Design Report and the Design Spec Sheet, while related, are independent documents and must be submitted as two (2) separate files.

C3.4 Design Report - Vehicle Drawings

C3.4.1 The Design Report must include one set of three (3) view drawings showing the vehicle, from the front, top, and side.

C3.4.2 Each drawing shall appear on a separate page. The drawings can be manually or computer generated.

C3.4.3 Photos should be placed on the optional page and will not be counted as drawings.

C3.5 Design Report and Design Spec Sheet Formats

C3.5.1 The Design Report must be submitted electronically in Adobe Acrobat Format (PDF). The document must be a single file (text, drawings and optional content are all inclusive). The maximum size for the file is 5 megabytes.

C3.5.2 Design Spec Sheets must be submitted electronically in Microsoft Excel® Format (*.xlsx file). The format of the Spec Sheet MUST NOT be altered.

WARNING: Failure to exactly follow the above submission requirements may result in exclusion from the Design Event. If your file is not submitted in the required format, then it cannot be made available to the Design Judges and your team will be excluded from the Design Event.

C3.5.3 Design reports must be submitted to the individual/address listed on the Action Deadlines page on the SAE International website (www.sae.org) and described in Part E of these rules. Reports must be received by the due date listed in the Action Deadlines. Design Report submission will be acknowledged on the submission website with a green indicator. Teams should have a printed copy of this acknowledgement available at the competition as proof of submission in the event of discrepancy.

C3.5.4 Penalty for Late Submission or Team cancel for Non-submission

Late submission or failure to submit the Design Report will be penalized ten (10) points per day. **If your Design Report is received more than five (5) days late it will be classified as “Not Submitted” and your team’s registration will be cancelled. See A7.3.1**

C3.5.5 Penalty for Unsatisfactory Submissions

At the discretion of the judges, teams that submit a Design Report which, in the opinion of the judges does not represent a serious effort to comply with the requirements of Rules C3.1 and C3.2 will also not compete in the design event, but may at the design judges’ discretion receive between five (5) and twenty (20) points for their efforts.

C3.5.6 Excess Size Design Reports

If a team submits a Design Report that exceeds four (4) pages of text, three (3) pages of drawing and one (1) optional page, then only the first four pages of text, three pages of drawings and first optional page will be read and evaluated by the judges. Note: If included, cover sheets and tables of contents will count as text pages.

C3.6 On-Site Design Evaluation

C3.6.1 The design judges will evaluate the engineering effort based upon the team’s Design Report, responses to questions, and an inspection of the car.

C3.6.2 The design judges will inspect the car to determine if the design concepts are adequate and appropriate for the application (relative to the objectives set forth in the rules).

C3.6.3 It is the responsibility of the judges to deduct points if the team cannot adequately explain the engineering and construction of the car.

C3.6.4 Design Judging Score Sheet

The Design Judging Score Sheet is available at www.bajasae.net/go/downloads. The judges strongly urge all teams to read and study the score sheet and all other documents related to design judging that are available on the website.

C3.6.5 Support Material

Teams may bring with them to Design Evaluation any photographs, drawings, plans, charts, example components, or other materials that they believe are needed to support the presentation of the vehicle and the discussion of their development process. Use of laptop or notebook computers, posters, and binders is allowed, but projectors may not be used.

C3.7 Judging Sequence

C3.7.1 The actual format of Design Evaluation may change from year to year as determined by the organizing body. The engineering design event student guide can be found at www.bajasae.net

C3.7.2 Design Evaluation is typically organized as follows:

1. Initial judging of all vehicles
2. Final judging ranking the top 3 to 10 vehicles.

C3.8 Design Finals

C3.8.1 The purpose of Design Finals (DF) is to reward, and call attention to, those vehicles judged to have the best engineering designs. DF are held after the conclusion of Design Evaluation so that the finalists may be chosen, and then judged as described in section C3.8.2. The number of finalists may vary from as few as three to as many as ten, as determined by the number of entries and the results of Design Evaluation.

C3.8.2 Design Finals Presentation- Format

One or more team members may make the presentation to the judges. The presentation itself is limited to a maximum of nine (9) minutes. Following the presentation there will be approximately one (1) minute for clarification questions from the judges. Only the judges are permitted to ask questions. Any team member on the presentation floor may answer the questions even if that member did not speak during the presentation itself.

Equipment

It is recommended that teams bring a laptop, binders or posters to show documentation or the engineering they have completed, but no projectors will be allowed.

C3.9 Top Ten Teams – Design Comparison Requirement

Teams with vehicles that finished in a top ten position in any of the previous year's Baja SAE® competitions are classified as having created a "successful design." Teams that created such successful vehicles are required to provide a comparison, using the template described below, of their current design with their previous year's design even if the current design is entirely new.

C3.9.1 As part of the design event, the judges will evaluate the comparison documentation of the Top Ten Teams. Team representatives may be required to be present during the comparison to discuss the design changes. If the judges find that the design changes are (A) not significant, (B) not supported by a detailed analysis, or (C) have not been sufficiently documented, then a penalty of up to one hundred (100) points may be assessed against the design score.

C3.9.2 Redesign/Design Comparison Document

The design comparison report must follow the template found at www.bajasae.net/go/downloads and should be accompanied with your design report as an addendum.

The documentation should be a year to year comparison of the major structure and/or systems of the vehicle and may consist of any, or all, of the following, supported by appropriate captions:

1. Plans,
2. Drawings
3. Photographs

Design changes to correct failures of the previous design should be accompanied by a thorough analysis of why the failure occurred and the theoretical data supporting the new design, etc. The comparison report must be attached to the design report as an addendum and submitted electronically in Adobe Acrobat Format (PDF). The document (design report and the design comparison document as an addendum) must be a single file (text, drawings and optional content are all inclusive)

C3.10 Duplicate Design

Teams are reminded that the objective of Baja SAE® is to provide students with a design challenge that will enhance their engineering and engineering project management skills. Participating teams must be able to demonstrate their engineering knowledge either by designing a vehicle from scratch or by making significant changes to a previously entered vehicle. If a school brings two vehicles that the design judges find to be either identical, or to exhibit only insignificant differences, then the cars will be treated as a single entry with a duplicate car for parts. In such case only one car will be evaluated and permitted to compete in the dynamic events.

C3.11 Scoring

C3.11.1 The engineering design event will be worth 150 points at the competitions.

C3.11.2 The judges may at their discretion award the highest placing team less than the maximum noted above. Design finalist may also receive bonus points that could make their scores higher than the maximum noted above.

ARTICLE 4: COST EVENT

C4.1 Cost consists of two related sections: Cost Report and Prototype Cost. The cost report provides all the background information to verify the vehicle's actual cost. The prototype cost is the actual cost and the points and the points related thereto.

C4.2 Cost Report

The Cost Report may contain a maximum of three sections.

C4.2.1 Report Section 1 – Overview (Optional) –

The optional overview is intended to give each team the opportunity to point out, and briefly comment on, any design features or fabrication processes that are innovative or are expected to result in significant cost savings. Teams may also use the overview to explain items or processes that might appear to be discrepancies within the report. The overview section is limited to a maximum of four (4) pages and is optional. This should be included as part of the Cost Documentation .pdf file.

C4.2.2 Report Section 2 – Costing Sheets –

The core of the report is the series of costing sheets. This section must contain the one-page summary sheet broken up into the individual subsystems. Each subsystem needs an individual sub-assembly sheet (Form A). Note that Vehicle Assembly Labor cost is for the labor it takes to assemble a subassembly to the frame. All fabricated parts on the sub-assemblies' sheets (Form A) require a Form B. Note that the sub-system assembly time is the time it takes to assemble all the parts in that assembly together.

C4.2.3 Report Section 3 – Cost Documentation – See Part E

This section includes copies of receipts, invoices, price tags, catalog pages, online prices, or other documentation, to substantiate the costs of the parts and materials of any item costing more than \$30. Cost documentation must be at full retail US prices. The use of foreign receipts, purchases from discount sites such as Craigslist, eBay or junk yards are not allowed. The report is expected to be comprehensive, well documented, truthful and accurate.

C4.2.4 Cost Report – Electronic Format See Part E Electronic version

1. The Microsoft Excel format (with the extension .xls (no macros) or .xlsx), using the supplied template posted on the Baja SAE® Important Documents page.

This document may not be modified from its current form. This includes password protecting and embedding macros. Teams will receive zero (0) points for Cost if the report is in the incorrect format or the files have been modified.

2. A PDF file with all of the cost documentation described above.

C4.2.5 Cost report Hard copy

Teams must bring a hard copy of their cost report to the cost judges on site. Teams that fail to bring a hard copy to judging may receive zero (0) for their cost.

C4.2.6 Multi-competition Cost Reports – U. S. and Canadian competitions only

Teams that are entering more than one North American Baja SAE® competitions must submit a single multi-competition cost report.

Multi-competition cost reports must (1) Identify all the competitions to which the report applies AND the vehicle number at each event. (2) Contain a unique event form documenting all differences between competitions.

C4.2.7 Penalty for Late or Non-Submission

Late submission or failure to submit the Cost Report will be penalized ten (10) points per day. **If your Cost Report is received more than five (5) days late it will be classified as “Not Submitted” and your team’s registration will be cancelled. See A7.3.1.**

COMMENT: It is the responsibility of the team to verify when the report was received on www.bajasae.net; submission time will be the time the report is received on www.bajasae.net. Teams will be cost audited at competition.

C4.2.8 Cost Correction

The judges may increase costs and/or fabrication times if they believe that the figures submitted are below current prices for the item, source, or process involved. Prices or times that are higher than the judge expects will not be corrected. Mathematical errors will be penalized. Reports that are highly inaccurate, highly incomplete, or in which the costs cannot be substantiated, may be rejected in their entirety and scored accordingly. Teams that are required to bring their car to on-site cost judging must do so by their scheduled appointment. Failure to report by the scheduled appointment time will result in an automatic zero for the event. If teams need to reschedule their appointment, it must be done prior to their appointment. Teams selected for cost audits will be notified prior to the event by SAE International as well at registration.

C4.2.9 Prototype Cost – 85 points

Prototype cost is scored on the cost, as corrected by the judges, to produce the finished vehicle brought to the competition.

Prototype cost score will be calculated as follows:

$$\text{Prototype Cost} = 85 \text{ points} \times \frac{C_{max} - C_{your}}{C_{max} - C_{low}}$$

where:

C_{your} Vehicle cost, as corrected
 C_{low} lowest vehicle cost, as corrected
 C_{max} highest vehicle cost, as corrected

C4.2.10 Cost Adjustment Form

The purpose of the cost adjustment form is to make additions to previously submitted report. Items may be deleted, but the total adjustment for the individual component categories must be positive (cost will not be subtracted). This gives the team the chance to add items that were not previously planned. It is not an opportunity to redo the entire report. For teams that are cost-audited and going to multiple races, the items found during the cost audit cannot be included in this sheet. The total amount of adjustments may not exceed 10% of the total cost of the vehicle previously submitted. If the adjustment exceeds 10%, the additional amount will be added with a multiplier of 3 times (3x). If the adjustment exceeds 25%, the report will be considered incomplete and will not be graded.

C4.2.11 Cost Eligibility

Teams that do not successfully pass technical inspection by 12:00 PM on the first day of dynamic events will not receive any points for prototype cost. Upon review of the data, the cost judge reserves the right to disqualify cost reports that have not been sufficiently validated (i.e. either through lack of documentation or outdated receipts), are determined to not be complete based on review, or are outside a reasonable level of cost based on the other cars in the competition (i.e. either too high or too low)

C4.2.12 Cost Component Categories

Teams must put items that are specified in the correct component categories and sub categories or the items will not be considered. See Cost Template for these.

ARTICLE 5: SALES PRESENTATION EVENT – all competitions – 50 Points

All teams are expected to participate in all static judging and may be excluded from dynamic events if they do not.

C5.1 Presentation – Objective

The objective of the Presentation is for the team to convince the “executives” of a hypothetical manufacturing company to purchase the team’s Baja SAE® vehicle design and put it into production at the rate of 4000 units per year.

C5.1.1 For the purpose of the presentation, teams are to assume that the judges are to be a mixed group of corporate executives who may have experience in marketing, production and finance as well as engineering.

C5.2 Presentation – Format

One or more team members may make the presentation to the judges. The presentation itself is limited to a maximum of ten (10) minutes.

C5.2.1 Following the presentation there will be an approximately five (5) minute question period.

C5.2.2 Only the judges are permitted to ask questions. Any team member on the presentation floor/stage may answer the questions even if that member did not speak during the presentation itself.

C5.3 Projection Equipment

Teams planning to use data projection are responsible for bringing, or otherwise arranging for their own data projectors. Some data projectors may be provided by the organizers; however, teams should not rely on either the availability or functionality of such equipment. Organizers cannot be held responsible if a team uses provided projector and programs are not compatible.

C5.4 Presentation – Scoring

C5.4.1 The presentation event will be scored based on such categories as

1. The content of the presentation,
2. The organization of the presentation,
3. The effectiveness of the visual aids,
4. The speaker’s delivery, and
5. The team’s responses to the judge’s questions. The team’s score will be the average of the individual judge’s scores.

C5.4.2 The team that makes the best presentation will receive the highest score regardless of the finished quality of their actual vehicle.

C5.4.3 Sales Presentation - Scoring – Bonus

The presentation judges shall apply bonus points to the top three (3) teams of the presentation event in the event of a tie. This bonus can range from 0-5 points and is applied at the discretion of the presentation judges.

PART D: DYNAMIC EVENTS- (U.S and Canadian Events) TOTAL – 700 POINTS

The dynamic events are intended to determine how the Baja SAE® vehicles perform under a variety of conditions. Note that the organizers may modify the dynamic events to address local conditions, weather or resources.

ARTICLE 1: ACCERLATION –75 Points

The Acceleration Event is designed to measure each vehicle’s ability to come up to speed quickly from a standing start.

D1.1 Acceleration – Objective

Acceleration is measured as the time to complete a 30.48 m (100 ft) or 45.72 m (150 ft) flat, straight course from a standing start. The course surface may vary from pavement to loose dirt.

D1.1.1 The choice of course length is at the organizer’s discretion.

D1.2 Acceleration – Procedure: Each vehicle may make two (2) attempts.

Stall at Start or Driving off Course = Run DQ’d

D1.2.1 Scoring will be based on the better of the two attempts. Timing will be done using an electronic timing system.

D1.3 Acceleration – Penalties

The organizer may modify the penalties imposed for different violations to account for differences in the length or design of specific event courses.

D1.4 Acceleration – Scoring

Vehicles with acceleration times that are more than 1.5 times that of the fastest vehicle will not receive a score for this event.

D1.4.1 Teams attempting the event, but exceeding the time limit will be classified as “Excess Time.”

D1.4.2 The following equation will be used for the acceleration score:

$$\text{Acceleratin Score} = 75 \text{ points} \times \frac{t_{\text{longest}} - t_{\text{yours}}}{t_{\text{longest}} - t_{\text{shortest}}}$$

where:

t_{shortest} fastest time by any vehicle

t_{yours} time for the vehicle to be scored

t_{longest} the lesser of : a) slowest time by any vehicle; b) $1.5t_{\text{shortest}}$

ARTICLE 2: HILL CLIMB or TRACTION EVENT- 75 POINTS

The Hill Climb Event is designed to measure each vehicle’s ability to transmit excess (climbing) force to the ground. If local terrain does not support a significant Hill Climb, a Traction Event may be substituted, usually involving pulling an excess load.

D2.1 Hill climb or Traction Event – Objective

This event tests the vehicle’s relative ability to climb an incline from a standing start or pull a designated object, e.g. “eliminator skid”, vehicle, or chain, along a flat surface. The organizer will determine the hill height steepness and surface or object to be pulled.

D2.2 Hill Climb or Traction Event – Procedure

Each vehicle may make two (2) attempts with the best time or distance counting for score. If a vehicle cannot complete the course and get a time, it will be scored on the distance that it travels before stopping. Once the vehicle stops moving forward the attempt is over and the attempt is scored for distance at that point. Vehicles may not continue the attempt after they have stopped on the course.

Driving off Course (DOC) = Score as maximum progress at point of DOC

D2.3 Traction Event – Penalties

The organizer may modify the penalty imposed for different violations to account for differences in the length or design of specific short event courses.

Although not recommended for this type of short event, a maximum of one (1) type of penalty may be defined by the event organizers

D2.4 Hill Climb or Traction Event – Scoring

D2.4.1 Method A: “Different Distances” – If none of the vehicles are able to complete the course, then:

$$\text{Hill Climb or Traction Score} = 75 \text{ points} \times \frac{d_{yours} - d_{shortest}}{d_{longest} - d_{shortest}}$$

where:

$d_{shortest}$ shortest distance traveled by any vehicle
 d_{yours} distance traveled by the vehicle to be scored
 $d_{longest}$ longest distance traveled by any vehicle

D2.4.2 Method B: “Fixed Distance-All Succeed” – If there is (a) a set maximum distance and (b) all teams succeed in completing a full distance hill or pull, then the score will be based on the time for the full distance.

$$\text{Hill Climb or Traction Score} = 75 \text{ points} \times \frac{t_{longest} - t_{yours}}{t_{longest} - t_{shortest}}$$

where:

$t_{shortest}$ fastest time by any vehicle
 t_{yours} time for the vehicle to be scored
 $t_{longest}$ the lesser of : a) slowest time by any vehicle; b) $2.5t_{shortest}$

D2.4.3 Method C: “Fixed Distance-Some Succeed”

If there is (a) a set maximum distance and (b) at least one team climbs the hill or makes a full pull and others do not, then the vehicles going the full distance (Group I) will be scored based on time and the vehicles that fail to climb the hill or make a full pull (Group II) will be scored based on distance.

Group I – Teams that make the full distance will be scored

$$\text{Hill Climb or Traction Score} = 75 \text{ points} \times \frac{t_{shortest}}{t_{yours}}$$

where:

$t_{shortest}$ fastest time by any vehicle
 t_{yours} time for the vehicle to be scored

Group II – Teams that do not make the full distance will be scored by the following:

$$\text{Hill Climb or Traction Score} = \text{lowestscorefromgroupI} \times \frac{d_{yours}}{d_{course}} \text{lowestscore}$$

where:

d_{yours} distance traveled by the vehicle to be scored
 d_{course} distance from start line to finish line

ARTICLE 3: MANEUVERABILITY EVENT –75 points

D3.1 Maneuverability – Objective

Maneuverability is designed to assess each vehicle’s handling ability over typical Baja terrain. The course may consist of a variety of challenges at the organizer’s option, possibly including tight turns, pylon maneuvers, ruts and bumps, drop-offs, sand, rocks, gullies, logs, and inclines.

D3.2 Maneuverability – Procedure

Each vehicle may make two (2) runs with the best time including penalties, counting for score.

Excessive Driving Off Course = Did Not Finish (DNF)

D3.3 Maneuverability – Penalties

The organizer may select a maximum of two (2) penalty types imposed for different violations to account for differences in the length or design of specific event courses.

Example Penalty Schedule:

Obstacle/Pylon/Cone moved	2 seconds
Missed gate*	10 seconds

*Missed gate is when 2 or more wheels are outside the gate

D3.4 Maneuverability – Time Limit

Only vehicles that complete the maneuverability course within a time not exceeding 2.5 times that of the fastest vehicle will receive a score. If a vehicle is on the course for a time that exceeds 2.5 times the fastest time recorded to that point, then the attempt may be declared over and the vehicle may be removed from the course and scored as “Excess Time.”

D3.5 Maneuverability – Scoring

Maneuverability scoring is based on the vehicle’s time through the course including any penalties.

$$\text{Maneuverability Score} = 75 \text{ points} \times \frac{t_{\text{longest}} - t_{\text{yours}}}{t_{\text{longest}} - t_{\text{shortest}}}$$

where:

t_{shortest} fastest time by any vehicle

t_{yours} time for the vehicle to be scored

t_{longest} the lesser of: a) slowest time by any vehicle; b) $2.5t_{\text{shortest}}$

ARTICLE 4: SPECIALTY EVENTS –75 points

D4.1 Specialty events are designed to test the vehicle under unique off-road conditions that might be available at some Baja SAE® competition sites.

D4.1.1 Examples of specialty events are: Rock Crawl; Mud Bog; and Suspension. Specialty events will be announced at the time of opening of registration for a competition.

The scoring system and penalties employed by the organizer must adhere to one of the options defined for either (a) the Maneuverability short event, or (b) the Traction short event.

ARTICLE 5: ENDURANCE – 400 Points

D5.1 Endurance – Objective

General: The endurance event assesses each vehicle’s ability to operate continuously and at speed over rough terrain containing obstacles in any weather conditions.

D5.2 Endurance – General Description

Endurance may be run for either time or distance. Endurance events for time usually run for four (4) hours. Endurance events for distance continue until at least one car has gone the specified distance.

D5.2.1 Endurance will be run as either (A) a single four (4) hour race, (B) a predetermined and published distance, or as (C) elimination heats followed by a final in which the total time of one elimination heat plus the final is 4 hours. The organizer (with approval from SAE International) will announce the structure of the event prior to the start.

D5.2.2 Determining the winner of the endurance race:

A. The team that completes the distance of the competition first, or the greatest distance in the time set for the competition will be declared the winner.

B. In competitions of a given distance, the checkered flag will be given first to the leading car, then to the other finishers as they cross the finish line.

- C. In competitions of a timed length, the checkered flag will be given first to the leading car as it crosses the finish line at or after the expiration of the specified duration, then to the other finishers as they cross the finish line.
- D. If the leading car is not running at the expiration of the time limit, the checkered flag will be given to the next highest running car in the same manner.

D5.3 Endurance – Starting

D5.3.1 The starting grid for endurance will be based on each team’s performance in a previous dynamic event, or set of dynamic events, to be determined by the organizer.

D5.3.2 All vehicles will be considered to have begun the race simultaneously at the time when the starter releases the first vehicle onto the course regardless of their actual position in the grid.

D5.4 Endurance – Command Flags

Command flags are just that – flags that the competitor must immediately obey without question.

D5.4.1 Green Flag

1. At a starting line or when reentering the course: Your run or session has started; enter the course under the direction of the starter. (**NOTE:** If you stall the vehicle, restart and await another green flag as the opening in traffic may have closed.)
2. While running on the course: Course is clear, proceed.



D5.4.2 Yellow Flag, Steady

Great danger, SLOW DOWN, evasive action is likely to be required, BE PREPARED TO STOP, something has happened beyond the flag station. NO PASSING, unless directed by the course workers.



D5.4.4 Red Flag

Come to an immediate safe and controlled stop on the course. Pull to the side of the course as much as possible to keep the course open. Follow course worker directions. NO PASSING.

D5.4.5 Black Flag, Furled and Pointed

Warning, the officials are watching this vehicle’s driving – obey the event rules.

D5.4.6 Black Flag, Displayed

1. Pull into the penalty box for a discussion with the Director of Operations or other official concerning an incident. A time penalty may be assessed for the incident.
2. Pull into the penalty box for a mechanical inspection of the car; something has been observed that needs closer inspection.

D5.4.8 Checkered Flag – The run or session has been completed. Exit the course at the first opportunity.

D5.5 Endurance – Stalled or Disabled Vehicles

D5.5.1 Disabled or stalled vehicles must be immediately removed from the roadway. It is the driver’s responsibility to assist and cooperate with the course marshals in removing the vehicle.

D5.5.2 Vehicles may only be started with the driver seated with all belts properly fastened.

D5.5.3 The driver may not exit the vehicle to execute a restart. Course marshals, volunteers or team members may assist drivers in restarting their vehicles.

D5.5.4 Officials and course marshals may stop any vehicle, at any time, if they believe it no longer complies with the requirements and restrictions of the rules.



D5.5.5 If a vehicle is stopped by officials for a mechanical fault, the fault must be corrected/repared before it may reenter the event.

D5.6 Endurance – Repairs

D5.6.1 No repairs are permitted on the course during the endurance competition. All work must be done in team paddocks

D5.7 Endurance Event – Penalties

D5.7.1 All timed penalties are enforced from when the vehicle is in the black flag area, i.e. the time spent being towed back to the pits does NOT count towards the penalty.

Infraction	1st Offense	2nd Offense	3rd Offense
Possession of fuel or active fueling outside the fuel area after endurance gridding closes	10 min	20 min	DQ
Fueling on track	DQ	-	-
Speeding in the pit area	5 min	20 min	DQ
Use of tools on the car in the fuel area	Warning	10 min	DQ
More than 3 people in the fuel area	Warning	10 min	DQ
Fueling with the driver in the car	30 min	DQ	-
Fire extinguisher not ready during fueling	10 min	20 min	DQ
Run out of fuel on track	5 min	5 min	5 min
Vehicle Rollover	-	Warning	DQ
Passing Under Yellow	Warning	Discretionary	Discretionary
Failure to stop for a black flag	10 min	Discretionary	Discretionary
Leaving the course and advancing	5 min	Discretionary	Discretionary
Aggressive driving	10 min	DQ	-

D5.7.9 Endurance Event Enforcement

- A. All cars must remain in the as-approved condition in order to compete; any condition that is deemed to not meet this requirement will be flagged to make necessary repairs.
- B. Any driver that is not using all of the approved and required drivers’ equipment will be flagged.
- C. Certain areas of the track have been identified as difficult obstacles. If your team is assisted two times on the same obstacle you will be black flagged and warned that one more assist will result in removal for the rest of the event.
- D. If the vehicle rolls over (ex. end over end) anywhere on the track three times, you will be removed from the event. Your team will be warned after the second roll over. What constitutes a roll over is up to the discretion of the National Techs.

D5.8 Fueling Area and Fueling Zone

The Fueling Zone (FZ) consists of the Fueling Area (FA), Fuel Quarantine Area (FQ), Crew Area (CA) and Harness Check Area (HC)

Only three (3) people from any given team, including drivers, are allowed within the Fueling Zone (FZ) at any one time.

D5.8.1 Fuel Storage Requirements

Each team shall have no more than two (2) approved fuel containers (refer to rule B12.9) in the Fueling Area (FA). Any additional fuel containers shall be placed in the Fuel Quarantine area (FQ) for the duration of the endurance event. All fuel must be in the Fueling Zone (FZ) by the time endurance gridding closes. Any team found with fuel in the paddocks

during the endurance event or found removing fuel from the Fueling Zone (FZ) without an escort from a National Tech Inspector prior to the end of the endurance event will be assessed a penalty as per Rule D5.8.5.

If a team wishes to remove their fuel from the Fueling Zone and leave the event site prior to the end of the endurance event, they must remove their “Passed Tech” sticker and provide it to a National Tech Inspector in exchange for their fuel.

All removable fuel tanks in the fueling area must comply with Rule B12.3.2 and have a cap with a check valve installed

D5.8.2 Work in fueling Area

No work requiring a tool may be performed in the Fueling Area. Teams are allowed to make adjustments that do not require any tools. Example (seat position, shock pre load, etc.)

Teams may only have approved fuel containers (refer to Rule B12.9), removable fuel tanks, fire extinguishers, and funnels, if required, in the Fueling Area. Tools of any kind, backpacks, wagons, extra driver equipment, and coolers are specifically prohibited.

D5.8.3 Refueling in Fueling Area

The fueling area is to be clear of anyone not immediately servicing a car.

Before removing the fuel tank cap or, in the case of a removable fuel tank, before unlatching the cover, the vehicle must be completely stopped, the engine must be shut off, the driver must be completely out of the vehicle, and a fire extinguisher must be pointed at the fuel transfer. The driver must not be tethered to the vehicle in any way (e.g. a cable connecting a headset to a radio mounted in the car). Any team found refueling with a driver in the vehicle or without a fire extinguisher present and pointed at the fuel transfer will be assessed a penalty as per Rule D5.8.5.

A fire extinguisher must be present and pointed at ANY transfer of fuel, including re-filling removable tanks or re-filling a smaller container from a larger one when a vehicle is not present.

D5.8.3.1 Maximum Fuel Container Size for Refueling Vehicles

Vehicles must be refueled using a fuel container no larger than 1.5 gallons in volume.

Any size of approved fuel container (refer to rule B12.9) may be used to refill a removable fuel tank when not installed in a vehicle, or to refill a smaller approved container on the ground.

D5.8.3.2 Removal of the Fuel Cap

When refueling during the endurance event, *the driver exiting the vehicle* must be the one to remove the fuel cap prior to fueling.

In the case of a removable fuel tank, the latch holding down the cover is considered equivalent to the fuel cap.

D5.8.4 Driving in Fueling Area

All cars must operate at a walking speed while in the Fueling Area and when entering/exiting the area. Any team found speeding in the fueling area will be assessed a penalty as per rule D5.8.5.

Cars may not be pushed into the Fueling Area (FA) without a driver present and prepared to drive (i.e. wearing all required safety equipment).

D5.8.5 Fuel Penalties

Fuel cans in the paddock (not impounded) during the Endurance Event – 10-minute penalty first time
or fuel removed from impound during endurance event without an escort 20-minute penalty second time

Fueling with any part of the driver in the car – 30-minute penalty first time
DQ second time

Fueling with extinguisher not present/pointed at the refueling exchange- 10 min penalty first time
20-minute penalty second time

D5.9 Endurance – Scoring

D5.9.1 General: The endurance event score is determined by (a) the number of laps each team completes during the endurance final and (b) the finish order of teams at the end of the event.

D5.9.2 “Scored laps” are the number of full laps actually completed during the endurance event final. Only full laps count, partial laps do not count for score. A vehicle must cross the counting/timing line under its own power for a lap to be counted.

D5.9.3 “Finish order” is the sequence in which vehicles cross the finish line after the lap scoring period has ended. Finish order determines the ranking of teams completing the same number of laps. For example, if the top four teams finish with the same number of laps, then they will be ranked 1st to 4th based on their finish order.

D5.9.4 “Bonus points” are additional points awarded to the first ten (10) vehicles on the leading (winning) lap, as separated by finish order as required, in part to differentiate teams finishing with the same number of scored laps. Up to 10 bonus points will be awarded in the inverse order of finish. Thus, the first vehicle to cross the finish line in the highest lap group will receive bonus points equal to the number of cars on the lead lap (max of 10); the second vehicle will receive one less bonus point etc. Example:

Position	Lap	Bonus Points
1	48	4
2	48	3
3	48	2
4	48	1
5	47	0

D5.9.5 Endurance scoring is based on number of laps the vehicle completes in the allowed time:

$$\text{Endurance Score} = 400 \text{ points} \times \frac{L_{yours} - L_{lowest}}{L_{highest} - L_{lowest}} + \text{bonus points}$$

Where:

$L_{highest}$ highest number of laps completed by any vehicle
 L_{yours} number of laps completed by the vehicle to be scored
 L_{lowest} lowest number of laps completed by any vehicle

D5.10 Endurance Heats plus a Final – Point Distribution: When endurance is run as heats plus a final, the points for the event will be distributed between the heats and the final in proportion to the time/distance of each stage.

D5.10.1 Thus, if endurance is run as one (1) hour eliminations plus a three (3) hour final, the four hundred (400) total points will be allocated as one hundred (100) points to each elimination heat plus three hundred (300) points to the final.

D5.10.2 Ties in the endurance race will be judged by the endurance event judge and may remain a tie. Ties for overall winner will be broken by the following criteria:
Endurance score
Total dynamic events score
Total static events score

If a tie remains after all the above tie-breakers, then the tie remains for the overall winner(s).

ARTICLE 6: COMPETITION PROCEDURES AND REGULATION – GENERAL

D6.1 Meetings

All team members identified as captains or drivers and all faculty advisors **MUST** attend all meetings as designated; Attendance at meetings is mandatory. Failure to attend meetings can result in disqualification of members or the entire team.

D6.2 Tie-breakers

Tie-breakers for dynamic events will be the second best run time or score for the given tied event. If both scores for tied teams in the event are equal, then the tie remains.

D6.3 Pre-inspection Operation Prohibited

Vehicles may not be started or driven prior to passing technical inspection, except as required as part of the inspection process itself.

D6.4 Engine governors are subject to check and resetting.**D6.5 Refueling**

Refueling of vehicles must be performed with (1) the engine shut-off and (2) the driver out of the vehicle and (3) fire extinguisher (other than that carried in the vehicle) must be on hand and pointed toward the vehicle/fuel tank whenever a vehicle is being refueled.

Teams found fueling improperly in the paddocks during the static or dynamic events days will be gridded for endurance in the fueling area and assessed a time penalty as per rule D5.8.5.

Refueling of vehicles must be performed with

1. Engine shut-off
2. Driver out of the vehicle
3. Fire extinguisher (other than that carried in the vehicle) must be on hand and pointed toward the vehicle/fuel tank whenever a vehicle is being refueled

D6.6 Engine and Drivetrain Inspection

Any vehicle may be inspected anytime during the competition. Any vehicle found to have: (1) altered or substituted its parts or equipment since passing technical inspection or (2) an engine in violation of the rules may receive a point deduction of 75 points each time it is found in violation.

D6.7 Engine Recall Option

The organizers and SAE International may, recall the engine from any vehicle in the competition in exchange for a new Briggs and Stratton engine. Recalled engines will not be returned and will be inspected at Briggs and Stratton's facilities to confirm compliance with the rules.

D6.8 Practice Area

Practice may only take place in officially designated areas.

ARTICLE 7: PADDOCK RULES**D7.1 Vehicle Movement – Walking Pace Required**

When a vehicle is driven anywhere except within the practice area or on event courses it must move at walking speed with a team member walking along side at a normal pace. During the performance events when the excitement is high, it is particularly important that vehicles move at a walking pace in the paddocks. The walking speed rule will be strictly enforced and point penalties will be assessed for violations.

- **Under no circumstances may anyone other than the driver, ride on a vehicle.**

D7.2 Team Work Area

The team's work area should be clearly defined and should be kept uncluttered at all times. When a team leaves their area, it must be left clean.

D7.3 Vehicles in the Paddocks

Only the Baja SAE® vehicles themselves and the teams' support trucks and trailers are allowed in the paddocks.

D7.4 Occupancy Restrictions

The organizers may limit the paddocks to team members, faculty advisors and competition officials.

D7.5 Compressed Gas Storage

Teams shall properly store compressed gas cylinders. Cylinders shall be upright and properly secured by chain or other method, capped when not in use, and stored such that cylinder temperature is below 125 degrees F.

All teams' members should be wearing eye protection in the paddock when performing any activity involving fuel, grinding welding or cutting.

ARTICLE 8: DRIVING RESTRICTIONS

D8.1 During the competition, Baja SAE® vehicles may only be driven between the paddocks and an event site, during official practice or in the events themselves and only after

DRIVING OFF-SITE IS ABSOLUTELY PROHIBITED. TEAMS FOUND TO HAVE DRIVEN THEIR VEHICLE AT AN OFF-SITE LOCATION MAY BE EXPELLED FROM THE COMPETITION.

ARTICLE 9: RULES OF CONDUCT

D9.1 All Baja SAE® participants can be proud of the excellent sportsmanship and cooperation among teams that are two of the hallmarks of the series. Good conduct and compliance with the rules and the official instructions are expectations and requirements for every team member.

D9.1.1 An incident of unsportsmanlike conduct, the organizer or SAE International Staff is authorized to impose an appropriate penalty.

D9.1.2 Unsportsmanlike conduct can include arguments with officials, disobedience of official instructions and the use of abusive or threatening language to any official or other participant. Depending on the seriousness of the infraction the penalty for such actions can range from a deduction of up to fifty percent (50%) of the team's points to expulsion of the entire team. Penalties of this type will only be imposed after a complete review of the incident by the organizer and SAE International staff.

D9.2 Alcohol and Illegal Material

Alcoholic beverages, firearms, weapons of any type and illegal materials are prohibited at Baja SAE® sites during the competition. The penalty for violation of this rule is the immediate expulsion of the entire team, not just the individual(s) involved. This rule applies to team members, advisors and any individuals working with the team on-site.

D9.3 Smoking–Open Toed Shoes Prohibited

Smoking and open toed shoes are prohibited in all competition areas.

D9.4 Parties

Disruptive parties either on or off-site must be prevented by the faculty advisor or team captain.

D9.5 Trash Clean-up

Clean-up of trash and debris is the responsibility of the teams. Please make an effort to keep your paddock area clean and uncluttered. At the end of the day, each team must clean their work area.

D9.6 Site Condition

Please help the organizers keep the site clean. The sites used for Baja SAE® are generally private property and should be treated as such. Competitors are reminded that they are guests. All trash should be placed in the receptacles provided. Glass is not allowed on the grounds. Failure to clean the premises will result in an unsportsmanlike conduct penalty. Competitors are encouraged to police their areas after meals.

D9.7 Motorcycles, Bicycles, Rollerblades, etc.—Prohibited

The use of motorcycles, quads, bicycles, scooters, skateboards, rollerblades or similar person-carrying or motor driven devices by team members and spectators in any part of the competition area, including the paddocks is prohibited.

ARTICLE 10: SPECTATOR RULES

D10.1 General

The organizers typically do not have a direct line of communication with spectators other than on-the-spot at the competition; thus, the competitors, faculty and volunteers are expected to help inform the spectators of the safety rules and help restrict spectators to the spectator areas.

D10.2 Alcoholic Beverages

Spectators may not drink or possess alcoholic beverages at any competition location.

D10.3 Access Restrictions

Spectators must keep a specified distance back decided by SAE International and the organizers, from any area where vehicles are operating under power. Motor vehicle competitions are potentially dangerous and safety rules will be strictly enforced.

D10.4 Children

A competition site is not a safe place for children and unsupervised young people. Spectators who fail to strictly control their children will be asked to leave the site.

D10.5 Removal of Spectators

The course officials and organizers have the absolute right to restrict spectator access to any parts of the site and to eject anyone who violates safety rules or ignores the instructions of officials.

D10.6 Unsafe Practices and Conduct

All participants are required to exercise safe practices and avoid unsafe activities at all times during the competition. The event organizer has the discretionary authority to impose a just penalty for any conduct deemed unsafe. All team members will be held to this rule. Open toed shoes are not permitted on site at any time.

ARTICLE 11: MISCELLANEOUS

D11.1 Driver Equipment

Drivers must wear all of the equipment specified in "Driver Equipment Requirements" and a properly fastened restraint system at all times when the vehicle is running in any event or on the practice track.

D11.2 Drivers not wearing the proper equipment will not be permitted to drive, and may have their competition driver's privileges revoked.

ARTICLE 12: SAFETY – TEAM RESPONSIBILITY

D12.1 Safety is the primary consideration in the design of Baja SAE® vehicles and the conduct of the competitions.

D12.2 Teams need to include safety considerations in all parts of their program.

D12.3 At all performance events, it is the responsibility of the team to ensure both the vehicle and driver meet and follow all the requirements and restrictions of the rules.

ARTICLE 13: VISA REQUESTS

Visa Requests

Affiliated CDS Student Team Members will have the ability to print out a Registration Confirmation Letter for the individual event(s) that they are attending. Once a student team member affiliates themselves to their team's profile page under their individual edit section. They will have the opportunity to print out their personalized letter with the following information: Student's Name, School's Name, the CDS Event Name, Official Dates and Location(s).

Please be advised that SAE International cannot intervene with, or call or send personal letters to, the State Departments, Embassies or Consulates of the United States or other governments on behalf of any meeting or event participant.

United States Visas

Teams requiring visas to enter to the United States are advised to apply at least sixty (60) days prior to the competition. Although most visa applications seem to go through without an unreasonable delay, occasionally teams have had difficulties and in several instances visas were not issued before the competition.

Do not wait - apply early for your visa.

Neither SAE International staff nor any competition organizers are permitted to give advice on visas, customs regulations or vehicle shipping. Nor will they intervene on either matter concerning the United States or any other country.

For additional information: <http://www.sae.org/events/travelvisa.htm>

PART E: DESIGN AND COST SUBMISSION PROCEDURES

ARTICLE 1: ONLINE SUBMISSIONS

Design and Cost Report Submission Process - <http://www.bajasae.net>

Forms - The standard forms that are required for documentation and submissions at Baja SAE® competitions have been relocated to www.bajasae.net/go/downloads

Web Based Submission - All three Baja SAE® competitions -the required documents must now be submitted online through <http://www.bajasae.net>

Account Signup for Online Submission- Teams must comply with certain requirements when registering at <http://www.bajasae.net/go/signup> and submitting documents online.

ONLINE SUBMISSIONS

Web Based Submission -

Teams competing in any North American Baja SAE® competition must submit the following documents online through <http://www.bajasae.net>

"Design Report"

"Cost Report"

"Cost Documentation"

"Design Spec Sheet"

- The Design Report and the Design Spec Sheet, while related, are independent documents and must be submitted as two (2) separate files.
- Documents may be uploaded to the website from the time your Baja SAE online account has been created and accepted until the "No Submissions Accepted After" deadline (which is 5 days after the "Due Date").
- Submissions may be replaced with new (updated) uploads at any time before the "Due Date" without penalty.
- Teams have the option to replace uploaded documents with a new file at any time, however between the
- "Submission Due Date" and the "No Submissions Accepted After" date such replacements are classified as late submissions and the appropriate penalties will be applied.
- Documents may not be uploaded or replaced following the "No Submissions Accepted After" deadline and late submission penalties will be applied.

Account Signup for Online Submission - Account creation for online document submission through Baja SAE® online requires the following steps:

- (1) Visit: <http://www.bajasae.net/go/signup>
- (2) Follow the account signup instructions on the website. Select "Your Affiliation" as either "Team Captain/Team Advisor" or "Team Member (non-captain)."
- (3) Your "authentication number" for Baja SAE® online signup is the confirmation number that was issued when your team registered on www.sae.org.

Note - There may be a delay of up to three (3) business days between the time your team registers for a competition and www.bajasae.net recognizes the validity of your authentication number and the captain can create his account.

Once your team captain has created an account it will remain valid until your team becomes dormant or no longer registers to compete.

(4) Responsibilities and Restrictions

Team Captain Role

Each team must have at least one person with an account at BajaSAE.net and identified as the Team Captain. The Team Captain(s) have unique responsibilities on the site including accepting other team members for site access. Until the captain accepts a member's signup request that person cannot upload or view team documents. Team captains automatically have the same roles and privileges as their team members.

Team Member Restrictions - Team members must be approved by the Team Captain or the Faculty Advisor before being able to view or upload team documents.

Note - All team members are not required to be affiliated on bajasae.net, just the person uploading documents or asking rules questions.

Uploading Documents - All team members and the team captain have equal authority to upload and/or replace documents in the name of the team.

Document Access - Uploaded documents can only be viewed by (1) members of the submitting team, (2) authorized judges, technical inspectors and officials and (3) CDS staff.

Reminder - The website does not know what you intended to submit or what you thought you were doing. Anything your team uploads to the site is considered to be an official action by your team.

SAE.org Website Actions	BajaSAE.net Website Actions
<ol style="list-style-type: none"> 1. Complete Program Submission 2. Update Team Website & Social Media 3. Pay Your Team Invoice 4. Affiliate all members through Team Profile 5. Reprint your Team Invoice 6. Print Registration Confirmation Letter 7. Print Participation Certificate 8. Print Fast Track Roster 	<ol style="list-style-type: none"> 1. Affiliate those Submitting Documents 2. Affiliate those Asking Rules Questions 3. Ask Rules Questions 4. Submit Required Documents

ARTICLE 2: NOTICE OF “POSSIBLE” RULE CHANGES FOR 2018:

- Beginning in 2018, all teams will be required to run an SAE specified Fuel Cell.
- A new frame fixture that will more closely fit the 95% percentile male.
- Frame requirements to be evaluated yearly
- Only one team per university- per competition/event

ARTICLE 3: APPENDIX S- SAE TECHNICAL STANDARDS

The SAE Technical Standards Board (TSB) has made the following SAE Technical Standards available online, **at no cost**, for use by Collegiate Design teams. Standards are important in all areas of engineering and we urge you to review these documents and to become familiar with their contents and use.

The technical documents listed below include both (1) standards that are identified in the rules and (2) standards that the TSB and the various rules committees believe are valuable references or which may be mentioned in future rule sets. All Collegiate Design Series teams registered for competitions in North America have access to all the standards listed below - including standards not specific to your competition.

SAE Technical Standards included in the CDS Rules

Baja SAE®

J586 - Stop Lamps for Use on Motor Vehicles Less Than 2032 mm in Overall Width
J759 - Lighting Identification Code
J994 - Alarm - Backup – Electric Laboratory Tests
J1741 - Discriminating Back-Up Alarm Standard

SAE Clean Snowmobile Challenge

J192 - Maximum Exterior Sound Level for Snowmobiles
J1161 - Sound Measurement – Off-Road Self-Propelled Work Machines Operator-Work Cycle

Formula Hybrid

J1318 - Gaseous Discharge Warning Lamp for Authorized Emergency, Maintenance and Service Vehicles
J1673 - High Voltage Automotive Wiring Assembly Design

Formula SAE®

SAE 4130 steel is referenced but no specific standard is identified
SAE Grade 5 bolts are required but no specific standard is identified

SAE Supermileage®

J586 - Stop Lamps for Use on Motor Vehicles Less Than 2032 mm in Overall Width

SAE Technical Standards for Supplemental Use

Standards Relevant to Baja SAE®

J98 – Personal Protection for General Purpose Industrial Machines – Standard
J183 – Engine Oil Performance and Engine Service Classification - Standard
J306 – Automotive Gear Lubricant Viscosity Classification - Standard
J429 – Mechanical and Material Requirements for Externally Threaded Fasteners – Standard
J512 – Automotive Tube Fittings - Standard
J517 – Hydraulic Hose - Standard
J1166 – Sound Measurement – Off-Road Self-Propelled Work Machines Operator-Work Cycle
J1194 – Rollover Protective Structures (ROPS) for Wheeled Agricultural Tractors
J1362 – Graphical Symbols for Operator Controls and Displays on Off-Road Self-Propelled Work Machines - Standard
J1614 – Wiring Distribution Systems for Construction, Agricultural and Off-Road Work Machines
J1703 - Motor Vehicle Brake Fluid - Standard
J2030 – Heavy Duty Electrical Connector Performance Standard
J2402 – Road Vehicles – Symbols for Controls, Indicators and Tell-Tales – Standard

Standards Relevant to SAE Clean Snowmobile Challenge

J44 – Service Brake System Performance Requirements – Snowmobiles - Recommended Practice
J45 – Brake System Test Procedure – Snowmobiles – Recommended Practice
J68 – Tests for Snowmobile Switching Devices and Components - Recommended Practice
J89 – Dynamic Cushioning Performance Criteria for Snowmobile Seats - Recommended Practice
J92 – Snowmobile Throttle Control Systems – Recommended Practice
J192 – Maximum Exterior Sound Level for Snowmobiles - Recommended Practice
J288 – Snowmobile Fuel Tanks - Recommended Practice
J1161 – Operational Sound Level Measurement Procedure for Snowmobiles - Recommended Practice
J1222 – Speed Control Assurance for Snowmobiles - Recommended Practice
J1279 – Snowmobile Drive Mechanisms - Recommended Practice
J1282 – Snowmobile Brake Control Systems - Recommended Practice
J2567 – Measurement of Exhaust Sound Levels of Stationary Snowmobiles - Recommended Practice

Standards Relevant to Formula SAE®

J183 – Engine Oil Performance and Engine Service Classification - Standard
J306 – Automotive Gear Lubricant Viscosity Classification - Standard
J429 – Mechanical and Material Requirements for Externally Threaded Fasteners – Standard
J452 - General Information – Chemical Compositions, Mechanical and Physical Properties of SAE Aluminum Casting Alloys – Information Report
J512 – Automotive Tube Fittings - Standard
J517 – Hydraulic Hose - Standard
J637 – Automotive V-Belt Drives – Recommended Practice
J829 – Fuel Tank Filler Cap and Cap Retainer
J1153 - Hydraulic Cylinders for Motor Vehicle Brakes – Test Procedure
J1154 – Hydraulic Master Cylinders for Motor Vehicle Brakes - Performance Requirements - Standard
J1703 - Motor Vehicle Brake Fluid - Standard
J2045 – Performance Requirements for Fuel System Tubing Assemblies - Standard
J2053 – Brake Master Cylinder Plastic Reservoir Assembly for Road Vehicles – Standard

Standard Relevant to Formula Hybrid

J1772 – SAE Electric Vehicle and Plug in Hybrid Conductive Charge Coupler

Standard Relevant to all CDS Competitions

J1739 – Potential Failure Mode and Effects Analysis in Design (Design FMEA) Potential Failure Mode and Effects Analysis in Manufacturing and Assembly Processes (Process FMEA) and Potential Failure Mode and Effects Analysis for Machinery (Machinery FMEA)

Reflections

Designing a prototype off-road vehicle for the Society of Automotive Engineers (SAE) Collegiate Design Series changed my thoughts on teamwork and project management. The scrutiny applied to this project by our faculty advisors and the SAE Technical Inspectors exceeded what I had come to expect from academic projects. I learned some important lessons about managing engineering projects including time-management, setting realistic engineering requirements, and overcoming internal and external challenges.

I believe the most important lesson derived from this project is the importance of creating a productive working mindset with a vision of the final product in its best possible form. At several points early in this design project, I felt that our progress was delayed by a lack of enthusiasm and decreasing quality standards. Without a clear vision of success, it was easy to lose focus and accept mediocre work. If we were to repeat this process, I would make an effort to sit down with the team several times throughout the project to reevaluate our goals and focus on the passion that inspired us to work on this project.

In addition, I learned that it is critical to set attainable but challenging engineering requirements as soon as possible. After four months of work on the vehicle design, we sat down as a team to replace the weak requirements we had created for ourselves at the outset, and these new requirements provided the direction necessary to achieve an acceptable design before the critical design review. Had we spent more time during the conceptual design phase creating good engineering requirements, I feel the final product could have been improved.

One issue that I should have expected from a long-term, team-oriented design project was difficulty with communication. Lack of communication between team members and with external stakeholders hampered progress and made it more difficult to realize personal expectations for the project. After some time, though, I was able to strike a balance between

independent work and highly collaborative work while communicating my challenges and frustrations with others. In the future, I hope this lesson improves the quality of my engineering work.

Overall, I value this project most not for the final product (an impressive off-road vehicle) but for the project management skills I have learned while working on it. I plan to apply these skills in my future engineering projects and further improve the quality of my project outcomes.

Author Biography

Michael Luke Scoggins is a new graduate in Mechanical Engineering from the Utah State University College of Engineering. He is the valedictorian of the Mechanical and Aerospace Engineering Department, and as an undergraduate, he was heavily involved in student research including topics such as heat transfer, nanosensors, and engineering education. He plans to work as a civilian engineer for the Navy at Puget Sound Naval Shipyard and Intermediate Maintenance Facility.