

University of Windsor

## Scholarship at UWindor

---

Electronic Theses and Dissertations

Theses, Dissertations, and Major Papers

---

1-1-2011

### Lower Extremity Isometric Training and its Effect on Type 2 Diabetic Claudication.

Martina Kovacevic  
*University of Windsor*

Follow this and additional works at: <https://scholar.uwindsor.ca/etd>

---

#### Recommended Citation

Kovacevic, Martina, "Lower Extremity Isometric Training and its Effect on Type 2 Diabetic Claudication." (2011). *Electronic Theses and Dissertations*. 7178.

<https://scholar.uwindsor.ca/etd/7178>

This online database contains the full-text of PhD dissertations and Masters' theses of University of Windsor students from 1954 forward. These documents are made available for personal study and research purposes only, in accordance with the Canadian Copyright Act and the Creative Commons license—CC BY-NC-ND (Attribution, Non-Commercial, No Derivative Works). Under this license, works must always be attributed to the copyright holder (original author), cannot be used for any commercial purposes, and may not be altered. Any other use would require the permission of the copyright holder. Students may inquire about withdrawing their dissertation and/or thesis from this database. For additional inquiries, please contact the repository administrator via email ([scholarship@uwindsor.ca](mailto:scholarship@uwindsor.ca)) or by telephone at 519-253-3000ext. 3208.

Lower Extremity Isometric Training and its Effect on Type 2 Diabetic Claudication

by  
Martina Kovacevic

A Thesis  
Submitted to the Faculty of Graduate Studies  
through Kinesiology  
in Partial Fulfillment of the Requirements for  
the Degree of Master of Human Kinetics at the  
University of Windsor

Windsor, Ontario, Canada  
2011  
© 2011 Martina Kovacevic



Library and Archives  
Canada

Bibliothèque et  
Archives Canada

Published Heritage  
Branch

Direction du  
Patrimoine de l'édition

395 Wellington Street  
Ottawa ON K1A 0N4  
Canada

395, rue Wellington  
Ottawa ON K1A 0N4  
Canada

*Your file* *Votre référence*  
ISBN: 978-0-494-81740-7  
*Our file* *Notre référence*  
ISBN: 978-0-494-81740-7

#### NOTICE:

The author has granted a non-exclusive license allowing Library and Archives Canada to reproduce, publish, archive, preserve, conserve, communicate to the public by telecommunication or on the Internet, loan, distribute and sell theses worldwide, for commercial or non-commercial purposes, in microform, paper, electronic and/or any other formats.

The author retains copyright ownership and moral rights in this thesis. Neither the thesis nor substantial extracts from it may be printed or otherwise reproduced without the author's permission.

#### AVIS:

L'auteur a accordé une licence non exclusive permettant à la Bibliothèque et Archives Canada de reproduire, publier, archiver, sauvegarder, conserver, transmettre au public par télécommunication ou par l'Internet, prêter, distribuer et vendre des thèses partout dans le monde, à des fins commerciales ou autres, sur support microforme, papier, électronique et/ou autres formats.

L'auteur conserve la propriété du droit d'auteur et des droits moraux qui protègent cette thèse. Ni la thèse ni des extraits substantiels de celle-ci ne doivent être imprimés ou autrement reproduits sans son autorisation.

---

In compliance with the Canadian Privacy Act some supporting forms may have been removed from this thesis.

Conformément à la loi canadienne sur la protection de la vie privée, quelques formulaires secondaires ont été enlevés de cette thèse.

While these forms may be included in the document page count, their removal does not represent any loss of content from the thesis.

Bien que ces formulaires aient inclus dans la pagination, il n'y aura aucun contenu manquant.

  
**Canada**

## **Author's Declaration of Originality**

I hereby certify that I am the sole author of this thesis and that no part of this thesis has been published or submitted for publication.

I certify that, to the best of my knowledge, my thesis does not infringe upon anyone's copyright nor violate any proprietary rights and that any ideas, techniques, quotations, or any other material from the work of other people included in my thesis, published or otherwise, are fully acknowledged in accordance with the standard referencing practices. Furthermore, to the extent that I have included copyrighted material that surpasses the bounds of fair dealing within the meaning of the Canada Copyright Act, I certify that I have obtained a written permission from the copyright owner(s) to include such material(s) in my thesis and have included copies of such copyright clearances to my appendix.

I declare that this is a true copy of my thesis, including any final revisions, as approved by my thesis committee and the Graduate Studies office, and that this thesis has not been submitted for a higher degree to any other University or Institution.

## Abstract

Individuals with type 2 diabetes (T2D) are prescribed aerobic exercise as treatment, however, peripheral arterial disease (PAD), a complication of T2D, restricts lower extremity blood flow causing claudication during the activity. Isometric exercise has been shown to increase local blood flow in other populations. This thesis tested the hypothesis that bilateral lower extremity isometric training would increase both initial (ICD) and absolute claudication distances (ACD) by increasing blood flow. Four males with T2D and PAD performed 4, 2-minute bilateral lower extremity isometric contractions at 30% of their maximal effort, 3X/week for 6-8 weeks. Pre and post-exercise ICD, ACD and blood flow were measured before and after the intervention. ICD and ACD increased  $116.3 \pm 26.3\%$  and  $47.5 \pm 34.1\%$ , respectively ( $Z=2.475$ ;  $p=.008$ ) with bilateral lower extremity isometric training, however, pre and post-exercise blood flow remained unchanged. These findings suggest that bilateral lower extremity isometric training increases ICD and ACD by a mechanism other than increased blood flow.

## Acknowledgements

I would like to thank the participants who took part in this study. Thank you for taking time out of your schedules to help me with this project. Furthermore, thank you for the companionship, great stories and life lessons shared throughout the study. Without you, this project would not have been possible.

I would also like to thank the institutions which supported me by opening their doors for participant recruitment: Windsor-Essex Chronic Disease Management Program, Windsor-Essex Cardiac Wellness Program, and the Windsor Regional Hospital Endocrinology, Nutrition and Diabetes Clinics. To Windsor Vascular Lab, thank you for not only allowing me to recruit participants, but also for inspiring this study's research and supporting me throughout this process in so many ways.

To the members of the PACR Lab, thank you for filling my years in grad school with countless laughs, smiles and experiences that will never be forgotten. A special thanks goes to Mike Gregory for being an excellent research assistant and sacrificing so much time to aid with data collection.

Thank you to the ladies at the Kinesiology front office, Pat McTaggart, Cathy Greenwell and Diane Dupuis. I very much appreciate the numerous times you accommodated all of my needs into your very busy schedules. Also, a much deserved thank you to Don Clarke for developing and building the materials and equipment which were integral to this study.

I also would like to acknowledge all of the members of my thesis committee: Dr. Kevin Milne, Dr. Karen Williamson and Dr. Neil McCartney. Your support, guidance, advice and time made this project the success it has become.

And finally, thank you to Dr. Cheri McGowan for the dedication and time spent on this project. Words cannot describe what you have meant to me during this entire process. Thank for believing in me and supporting me when I needed it. You were always there to calm me down and cheer me up during the rough times. And you were always there to share a laugh during the funny, and sometimes awkward, times. You have been such a great advisor and even more importantly, an amazing role model and friend.

## Table of Contents

<b>Title</b>	<b>Page</b>
Author’s Declaration of Originality.....	iii
Abstract.....	iv
Acknowledgements.....	v
List of Tables.....	viii
List of Figures .....	ix
List of Appendices.....	x
List of Abbreviations.....	xi
Chapter 1: Introduction and Literature Review.....	1
1.1 Diabetes Mellitus (DM).....	2
1.1.1 Introduction.....	2
1.1.2 Blood Glucose Regulation.....	2
1.1.3 DM- A Closer Look: Types, Pathophysiology and Risk Factors.....	6
1.1.4 Complications of DM .....	12
1.1.5 Recommendations for the Treatment of DM.....	23
1.2 Peripheral Arterial Disease in DM.....	29
1.2.1 Peripheral Arterial Disease (PAD).....	29
1.2.2 Methods of Assessing PAD.....	30
1.2.3 Treatment Recommendations for PAD.....	33
1.3 Summary of Background.....	42
1.4 Thesis Objectives.....	44
1.5 Specific Hypotheses.....	44

1.6 Clinical Relevance.....	44
Reference List.....	46
Chapter 2: Lower Extremity Isometric Training and its Effect on Type 2 Diabetic Claudication: Manuscript.....	62
2.1 Introduction.....	63
2.2 Purposes and Hypotheses.....	67
2.3 Methods.....	67
2.3.1 Participants.....	67
2.3.2 Study Design.....	68
2.4 Results.....	74
2.5 Discussion.....	76
2.6 Limitations.....	78
2.7 Conclusion.....	80
2.8 Clinical Relevance.....	81
Reference List.....	82
Tables.....	90
Figures.....	97
Appendices.....	117
Vita Auctoris.....	140



## List of Tables

<b>Table</b>	<b>Page</b>
1. Summary of the Differences Between Type 1, Type 2 and Gestational Diabetes..	91
2.1 Participant Characteristics: Age, Sex and Race.....	92
2.2. Participant Characteristics: Peripheral Arterial Disease-Related.....	92
2.3 Participant Characteristics: Type 2 Diabetes-Related.....	92
2.4 Participant Characteristics: Physical Activity History.....	93
3.1 Raw Data: Popliteal Artery Diameters.....	94
3.2 Raw Data: Popliteal Artery Timed-Average Mean Velocity.....	94
3.3 Raw Data: Resting Ankle-Brachial Index.....	94
3.4 Raw Data: Pre & Post-Exercise Session Blood Glucose Measurements.....	95
4.1 Results Table: Initial Claudication Distance (ICD)/Absolute Claudication Distance (ACD).....	96
4.2 Results Table: Pre-Exercise Blood Flow.....	96
4.3 Results Table: Post-Exercise Blood Flow.....	96

## List of Figures

Figure	Page
1. The Negative Feedback System of Control for Blood Glucose.....	98
2. Glycolysis in the Sarcoplasm of the Beta Cell.....	99
3. The Krebs's Cycle in a Mitochondrion of the Cell.....	100
4. The Electron Transport Chain in a Mitochondrion.....	101
5. Beta Cell Glucose Uptake and Insulin Release.....	102
6. Insulin-Stimulated GLUT4 Translocation in a Muscle Cell.....	103
7. Glycogenesis in Skeletal Muscle and Liver Cells.....	104
8. Ketone Body Formation in the Liver and Breakdown in Skeletal Muscle.....	105
9. Vasodilation Caused by the Effect of Nitric Oxide in a Smooth Muscle Cell.....	106
10. Formation of Nitric Oxide in an Endothelial Cell.....	107
11. Formation of Reactive Oxygen Species instead of Nitric Oxide in the Presence of Dyslipidemia/Hyperglycemia.....	108
12. Foam Cell Formation from Low-Density Lipoproteins in an Endothelial Cells..	109
13. Conversion of Dihydroxyacetone Phosphate into Diacylglycerol.....	110
14. Protein Kinase C and Smooth Muscle Contraction.....	111
15. Smooth Muscle Cell Proliferation Caused by Hyperinsulinemia.....	112
16. ATP Production in the Phosphagen Energy System.....	113
17. GLUT4 Translocation caused by AMP Protein Kinase.....	114
18. Lipolysis: The Breakdown of Triacylglycerol into Glycerol and 3 Fatty Acids...	115
19. Creation and Lifespan of High-Density Lipoproteins.....	116

## List of Appendices

<b>Appendix</b>	<b>Page</b>
A. University of Windsor Review Ethics Board Consent .....	118
B. Windsor Regional Hospital Research Ethics Board Consent.....	119
C. Poster Advertisement.....	120
D. Letter of Information for Consent to Participate in Research.....	121
E. Consent to Participate in Research.....	124
F. Medical Questionnaire.....	127
G. Physical Activity Readiness Medical Examination (PARmed-X).....	128
H. Personal Medical History Questionnaire.....	132
I. Release of Medical Information.....	133
J. Automated Arterial Oscillometry Device.....	134
K. Duplex Ultrasound Machine.....	135
L. Gardner Protocol.....	136
M. Blood Glucose Monitoring System.....	137
N. Spring-Loaded Lancet.....	138
O. Lower Leg Isometric Training Apparatus (LoLITA).....	139

## Abbreviations

ABC	adenosine triphosphate binding cassette	GD	gestational diabetes
ABI	ankle-brachial index	GLUT2	glucose transporter protein 2 (beta cell)
aCoA	acetyl Coenzyme A	GLUT4	glucose transporter protein 4 (muscle cell)
ACE	angiotensin converting enzyme	H <sup>+</sup>	hydrogen ion
ADMA	asymmetrical dimethylarginine	H <sub>2</sub> O	2 hydrogen ions and an oxygen ion (water)
ADP	adenosine diphosphate	hr	hour
AMP	adenosine monophosphate	HDL	high-density lipoprotein
AMPK	adenosine monophosphate kinase	IP <sub>3</sub>	inositol-1,2,5-triphosphate
APOA-1	apolipoprotein A1	K <sup>+</sup>	potassium ion
ATP	adenosine triphosphate	Kg	kilogram
BP	blood pressure	LCAT	lecithin cholesterol acyl transferase
cAMP	cyclic adenosine monophosphate	LDL	low-density lipoprotein
cm	Centimeter	LoLITA	lower leg isometric training apparatus
d	day	m	meter
DHAP	dihydroxyacetone phosphate	MAPK	mitogen activated protein kinase
DM	diabetes mellitus	mg	milligram
ECG	electrocardiogram	mi	mile
eNOS	enzyme nitric oxide synthase	min	minute
ET-1	endothelin 1	ml	milliliter
FAD	flavin adenine dinucleotide	mM	millimol
FADH <sub>2</sub>	flavin adenine dinucleotide and 2 hydrogen ions	mmHg	millimeter of mercury

mph	miles per hour	$r^2$	radius squared
MVC	maximum voluntary contraction	ROS	reactive oxygen species
NAD	nicotinamide adenine dinucleotide	sec	second
NADH+H	nicotinamide adenine dinucleotide and 2 hydrogen ions	SOLES	sustained optimal load exercise software
P	Phosphate	T1D	type 1 diabetes
PACRLab	physical activity & cardiovascular research lab	T2D	type 2 diabetes
PAD	peripheral arterial disease	v	velocity
PARMed-X	physical activity readiness medical questionnaire	VSMC	vascular smooth muscle cell
PIP <sub>2</sub>	phosphatidylinositol-4,5- biphosphate	wk	week
PPi	Pyrophosphate		

## **CHAPTER 1: Introduction and Literature Review**

## **1.1 Diabetes Mellitus (DM)**

### **1.1.1 Introduction**

Diabetes mellitus (DM) is a disease characterized by elevated blood glucose (hyperglycemia) due to inadequate insulin secretion or action (Centers for Disease Control and Prevention, 2010). It affects over 180 million people worldwide, a figure that will likely double by 2030 (World Health Organization, 2008). DM is a prominent risk factor for the world's leading cause of death, cardiovascular disease, and over half of the individuals diagnosed with diabetes die before the age of 70 (World Health Organization, 2009a; Grundy et al., 1999). The only non-infectious disease classified as an epidemic, DM is not the result of genetic factors alone, as both the environment and/or an individual's behaviour (such as a sedentary lifestyle and high calorie diet) often play a major role in its development (World Health Organization, 2008; Zimmet, Alberti, & Shaw, 2001).

Before discussing, in detail, the different types of DM, it is important to first understand blood glucose and its regulation in a healthy population.

### **1.1.2 Blood Glucose Regulation**

#### ***Blood Glucose***

Glucose, a monosaccharide or simple sugar, is a type of carbohydrate (molecules composed of atoms of carbon, hydrogen and oxygen), a fuel that can rapidly provide the body with energy (National Diabetes Information Clearinghouse, 2008). Blood glucose

refers to the amount of glucose present in blood (Canadian Diabetes Association, 2008). The normal fasting blood glucose level in humans is 4.0 mM-6.0 mM (Canadian Diabetes Association, 2008). With the ingestion of food or drink composed of this simple sugar, the blood glucose level will rise and alter the body's internal environment (National Diabetes Information Clearinghouse, 2008).

### ***Negative Feedback and Blood Glucose Regulation Mechanisms***

One of the goals of the human body is to maintain a constant internal environment or homeostasis. The regulation of blood glucose is accomplished through a negative feedback system. In general terms, this negative feedback system is composed of three elements: a sensor, a control center and effectors. A change in the internal environment acts as a stimulus that is detected by the sensor. The sensor sends a signal to the control center which assesses the amount of change that has occurred in the internal environment, then the control center sends the appropriate signal to the effectors. The effectors produce a response to correct the change in the internal environment that was detected. This feedback system is considered a negative feedback system because the response it produces is negative or opposite of the stimulus. (Powers & Howley, 2009)

In relation to blood glucose regulation, a blood glucose concentration that is elevated above normal (a change in the internal environment) is the stimulus detected by the sensor (the pancreas) and the signal sent to the effector (also the pancreas) from the control center is to increase insulin secretion (insulin is responsible for increased glucose uptake by cells) which, in turn, decreases the blood glucose concentration (see Figure 1) (Aserita, 1985).



Blood glucose regulation mechanisms are responsible for the success of this negative feedback system. After the digestion of a meal or drink containing carbohydrates blood glucose levels can increase to levels as high as 8 mM (Jewell, Oh, & Thurmond, 2010; Canadian Diabetes Association, 2008). The glucose molecules (which have increased in number) travel through the bloodstream to pancreatic beta-cells (Jewell, Oh, & Thurmond, 2010). These molecules then attach to the membrane spanning glucose transporter proteins (GLUT2) of the beta-cell and enter via facilitated diffusion (Inagaki et al., 1992). While in the beta-cell, glucose is acted on by the enzyme glucokinase to produce glucose-6-phosphate and it undergoes the processes of glycolysis (see Figure 2), the Krebs's cycle (see Figure 3) and the electron transport chain (see Figure 4) to produce molecules of the energy compound adenosine triphosphate (ATP) (Inagaki et al., 1992).

The resultant increase in ATP is responsible for closing the ATP-sensitive potassium channels located on the beta-cell membrane and this leads to the depolarization (membrane potential is dependent on potassium flux) of the membrane, thus opening the voltage-gated calcium channels and allowing calcium to enter the cell (Atwater, Dawson, Eddlestone, & Rojas, 1981). This increase in calcium in the cell induces the release of more calcium from the intracellular endoplasmic reticulum by activating phospholipase C which cleaves phosphatidylinositol-4,5-biphosphate (PIP<sub>2</sub>) into inositol-1,4,5-triphosphate (IP<sub>3</sub>) and diacylglycerol (IP<sub>3</sub> binds to a receptor protein in the endoplasmic reticulum initiating calcium release) (Atwater et al., 1981). The further increase in calcium causes the release of insulin from the beta-cell by influencing exocytosis (see Figure 5) (Jewell, Oh, & Thurmond, 2010).

The newly released insulin binds to insulin receptors on skeletal and cardiac muscle cells and this action causes the activation of the enzyme tyrosine kinase which phosphorylates (activates through the donation of a phosphate ion from adenosine triphosphate breakdown) insulin receptor substrate proteins (Robinson & Buse 2008). The activated insulin receptor substrate proteins then bind to and subsequently activate phosphatidylinositol-3 kinase which in turn activates protein kinase B (Robinson & Buse, 2008). Protein kinase B phosphorylates the protein AS160 (which is responsible for converting the Rab protein into its inactive form of guanosine diphosphate) and dissociates it from the glucose transporter protein located inside the muscle cell (GLUT4) (Hardie, 2002). Once dissociated, AS160 no longer promotes the Rab-guanosine diphosphate conversion and the Rab gets converted into its active form, guanosine triphosphate which causes the translocation of GLUT4 to the cell membrane (Klip & Paquet, 1999; Hardie, 2002). It should be noted that at all times there are GLUT4s located on the cell membrane, but the aforementioned process increases the number of GLUT4s located on the cell membrane (Klip & Paquet, 1999). Extracellular glucose molecules enter the cell by binding to the membrane spanning GLUT4s (see Figure 6) (Klip & Paquet, 1999). Once inside the muscle cell, the glucose can be broken down during glycolysis (see Figure 2), the Krebs' cycle (see Figure 3) and the electron transport chain (see Figure 4) to produce energy compounds (such as ATP) or it can be converted into stored energy in the form of glycogen through glycogenesis (see Figure 7).

As glucose progressively enters the muscle cells, blood glucose levels fall concurrently, with an eventual return to within a normal range (Jewell, Oh, & Thurmond, 2010). This is the end result of the negative feedback system under normal conditions

(Powers & Howley, 2009). In a pathology such as DM, some of the mechanisms do not work properly and blood glucose levels do not return to normal unless a form of therapy is administered (Canadian Diabetes Association, 2008).

### **1.1.3 DM- A Closer Look: Types, Pathophysiology and Risk Factors**

The DM population can be divided into three groups: Those with type 1 diabetes (T1D; the body lacks insulin), those with type 2 diabetes (T2D; the body is resistant to insulin) and those with gestational diabetes (GD; affects women during pregnancy) (see Table 1) (Berg, 1986).

#### ***Type 1 DM (T1D)***

##### ***Pathophysiology of T1D***

Although the causes of type 1 DM (T1D) have long been purported to be genetic and/or environmental another prominent theory in the diabetes literature is that individuals are insulin-dependent because the beta-cells of the pancreas that produce insulin are destroyed by the body in an autoimmune attack (Cihakova, 2001).

The trigger and the process for this autoimmune attack are still unknown (Cihakova, 2001). One theory involves cytotoxic T-cells. Cytotoxic T-cells are lymphocytes (white blood cells) that destroy viruses, infected cells and cells labeled by programmed cell death (these cells usually have a bulging or unattached cell membrane) (Ueda et al., 2003). The cytotoxic T-cells infiltrate the islets of Langerhans (the area

within the pancreas where the beta-cells are situated) and begin destroying beta-cells (Ueda et al., 2003).

Whatever the cause, the destruction of beta-cells means that insulin cannot be produced or secreted by the body. Thus, the negative feedback system fails and hyperglycemia results (American Heart Association, 2011). As in healthy individuals, after ingestion of carbohydrates, blood glucose increases in a person with T1D (Canadian Diabetes Association, 2008). Glucose molecules travel through the blood stream and in healthy individuals, some glucose molecules travel to the pancreatic beta-cells to stimulate insulin secretion. In contrast, with T1D, there are no beta-cells to travel to and thus no insulin to release (Kloppel, Lhor, Habich, Oberholzer, & Heitz, 1985). Insulin is responsible for increasing the number of GLUT4s (glucose transporter proteins) on the muscle cell membrane (Klip & Paquet 1999). Without insulin, the number of GLUT4s during this state of increased blood glucose concentration remains the same as during the state of fasting blood glucose concentration (Klip & Paquet, 1999). There are too many glucose molecules for the GLUT4s to transport into the muscle cell and hyperglycemia results. The destruction of the beta-cells can progress for many years before it is detected and this is because symptoms (such as hyperglycemia and ketoacidosis) only develop when 90% of the cells have been destroyed (Cihakova, 2001).

### ***Risk factors for T1D***

Individuals with T1D may have a genetic predisposition to contracting the disease. If a female under the age of 25 years with T1D gives birth, her child has a 1 in 25 chance of developing T1D, but the risk decreases as the age of the birthing mother

increases (Permutt, Wasson, & Cox 2005). If a man has T1D, then the chances of his child developing the disease are 1 in 17, but if both parents have T1D then the risk can increase to 1 in 4 (Permutt et al., 2005). In addition, there are some environmental factors associated with T1D disease development. It has been noted that T1D develops more frequently in children who live in places with cold climates and in children who were exposed to a viral infection (American Diabetes Association, 2009). Also, children who were not breastfed and began eating solid foods at an earlier age had a greater chance of developing T1D (Permutt et al., 2005). Even though individuals may differ in the method of contracting T1D, they all share the commonality of destroyed or decreased pancreatic beta-cells (Kloppel et al., 1985).

### ***Type 2 DM (T2D)***

Type 2 DM (T2D) is also known as adult-onset, insulin-resistant or noninsulin-dependent diabetes, and accounts for 90-95% of all the documented DM cases (University of Virginia Health System, 2007; Berg, 1986). T2D is considered adult-onset because the disease usually affects individuals after the age of 40 years, although there has been a recent significant increase in the number of children under the age of 16 years who develop the disease (Berg, 1986; American Diabetes Association 2009). Individuals are non-insulin dependent because although the body has the beta-cells to produce insulin, the muscle cells are resistant to it (Weyer, Bogardus, Mott, & Pratley, 1999). Hyperglycemia results from the delayed glucose uptake by muscle cells on account of the insulin resistance, and the negative feedback system fails (Weyer et al., 1999). T2D occurrence depends on genetic predisposition and environmental influence (Canadian Diabetes Association, 2011).

## *Pathophysiology of T2D*

There are four stages in the development of T2D (Weir & Bonner-Weir, 2004). These stages are insulin resistance, altered beta-cell function, continuous increase of fasting blood glucose concentration and disease (Weir & Bonner-Weir, 2004). In the first stage, the beta-cells produce insulin in response to increased blood glucose levels, but the muscle cells have a reduced ability to take up glucose at that particular blood insulin concentration (Weir & Bonner-Weir, 2004). The muscle cells' insulin receptors do not allow any insulin to bind and the GLUT4s are not translocated to the cell membrane to increase the transport of glucose into the cell (Klip & Paquet, 1999). The beta-cells, in turn, produce more insulin in an attempt to increase insulin-insulin receptor binding and promote increased glucose uptake (Weir & Bonner-Weir, 2004). This increase in insulin production causes the beta-cells to increase in number and size (Weir & Bonner-Weir, 2004). In some individuals, the beta-cells cannot produce the amount of insulin needed for adequate insulin-insulin receptor binding and adequate glucose uptake, and hyperglycemia results (Weir & Bonner-Weir, 2004).

The phenomenon of insulin resistance and its causes are still not fully understood. It is unknown why the muscle cells become resistant to the insulin that is secreted to increase glucose uptake. There are, however, some common characteristics among individuals with insulin resistance such as abdominal obesity (a waist circumference of greater than 102 cm and 88 cm in men and women, respectively), dyslipidemia (an abnormal lipid profile of hypertriglyceridemia (increased triglyceride levels of >1.7 mM), high low-density lipoprotein (LDL) (>3.4 mM) and a low level of high-density lipoprotein (HDL) (<1.0 mM and <1.3 mM in men and women, respectively)),

hypertension (sustained elevations in resting arterial blood pressure; BP) and increased fasting blood glucose concentration. Although the causes of insulin resistance are unknown, a potential long term outcome is T2D. (Canadian Diabetes Association, 2008)

The second stage of T2D development is altered beta-cell function. With insulin resistance and decreased glucose uptake, an individual's fasting blood glucose level increases from the normal  $\sim 4.0$  mM to  $>5.6$  mM (Brunzell et al., 1976). As fasting blood glucose levels approach 5.6 mM, beta-cells begin to secrete less insulin (Brunzell et al., 1976). Combined with insulin resistance, this decrease in insulin secretion contributes to hyperglycemia because less insulin is available to help promote glucose uptake (Weir & Bonner-Weir, 2004). Eventually the fasting blood glucose levels are increased beyond 6.7 mM, a level at which insulin secretion almost completely ceases (Brunzell et al., 1976). The molecular mechanisms behind the loss of insulin secretion are unknown, but glucose toxicity offers a potential explanation (Brunzell et al., 1976). Beta-cells function in an optimal range of blood glucose concentration (4.0 mM-6.0 mM) and if the blood glucose levels increase too high ( $>6.7$  mM), the constant internal environment changes and the functions of the beta-cells begin to alter and almost cease (Brunzell et al., 1976). Altered beta-cell function and loss of insulin secretion lead to even less glucose uptake and a greater degree of hyperglycemia (Weir & Bonner-Weir, 2004).

In the third stage of T2D development, the fasting blood glucose levels continue to rise above 7.4 mM due to the insulin resistance of muscle cells and the impaired insulin secretion of the pancreatic beta-cells. From stage three, it can take an individual several years before they reach stage four, fully developed T2D. In stage four, the body produces just enough insulin to allow muscle cells to take up some glucose and combat

ketoacidosis (decrease in arterial pH due to the presence of excessive ketones from fat metabolism in lieu glucose metabolism) (Weir & Bonner-Weir, 2004)

### ***Risk factors for T2D***

Environmental factors have a significant influence on T2D development (American Diabetes Association, 2004). Individuals who are obese or who lead the “Western” lifestyle (calorie-rich diet, high-fat diet and low physical activity) are at risk for T2D, especially if they have a family history of the disease (Malecki, 2005). If one parent has been diagnosed with T2D before the age of 50 years, then the child has a 1 in 7 chance of developing T2D, but the risk does decrease as the parent’s age of onset increases (Malecki, 2005). If both parents have been diagnosed with T2D at any age, then the child has a 1 in 2 chance of developing T2D (Malecki, 2005).

### ***Gestational Diabetes (GD)***

Gestational diabetes (GD) affects approximately 4% of all pregnant women, and represents new-onset hyperglycemia and T2D during pregnancy (Canadian Diabetes Association, 2009; Campbell et al., 2009). Women who are above the age of 35 and/or are obese have an increased risk of developing GD (Canadian Diabetes Association, 2009). Also women who have had GD in the past or have given birth to overgrown babies increase their chances of developing the condition (Canadian Diabetes Association, 2009). If an affected woman does not control her GD, not only does she increase her risk of developing T2D later in life (Canadian Diabetes Association, 2009), she increases nutrient availability to her fetus which contributes to fetal overgrowth and adiposity (Catalano, Kirwan, Haugel-de Mouzon, & King, 2003).



### *Pathophysiology and risk factors for GD*

Much like T2D, the exact cause of GD is unknown, but insulin resistance (see **Pathophysiology of type 2 diabetes**) is an integral part of the condition (Catalano et al., 2003). Another potential cause of GD is abnormal beta-cell sensing of glucose (Catalano et al., 2003). On the pancreatic beta-cell, the glucose sensor and transporter is GLUT2 (Inagaki et al., 1992) and by means unknown, GLUT2 functions become impaired and beta-cell does not take up glucose or release insulin and the outcome is hyperglycemia (Inagaki et al., 1992; Catalano et al., 2003).

#### **1.1.4 Complications of DM**

DM has many associated complications, some of which are specific to the form of DM, and some of which are common among all three types (Canadian Diabetes Association, 2008). One of the most common complications of T1D and a leading cause of hospitalizations is ketoacidosis, which occurs if an individual fails to administer a sufficient amount of insulin (Berg, 1986). Complications that are common among individuals with DM regardless of the type are neuropathy (nerve disease), nephropathy (kidney disease), endothelial dysfunction and hypertension (high systemic arterial blood pressure) (Canadian Diabetes Association, 2008). No matter the type of complication, the side effects can be very serious and even deadly (Canadian Diabetes Association, 2008).

## ***Ketoacidosis***

Ketoacidosis is a condition which affects individuals with T1D, although there have been rare cases of individuals with T2D with the condition (Berg, 1986). With inadequate administration of exogenous insulin (a common treatment for T1D discussed below in the section titled ***Pharmacological Treatment Options for DM***), glucose cannot be used to produce the energy compounds needed to fuel the body. To review, insulin increases the number of glucose transporters (GLUT4s) on the muscle cell membrane that are responsible for glucose entry into the cell (Klip & Paquet, 1999). Without insulin, the increase in GLUT4s does not occur (Klip & Paquet, 1999) and inadequate glucose is transported into the cell therefore, the body needs to rely on another source to create energy compounds (such as ATP) that will be use in bodily processes. The alternative energy sources are ketone bodies (Fery & Balasse, 1985).

Ketone bodies are created in the liver and are used as a source of fuel when the muscle cells are unable to use glucose in glycolysis and the Kreb's cycle for fuel (Fery & Balasse, 1985). Specifically, the liver acquires acetyl coenzyme A (acCoA) from the oxidation of fatty acids and two molecules of acCoA are acted upon by the enzyme thiolase to form acetoacetyl coenzyme A which is eventually converted into the ketone body acetoacetate (Hird & Symons, 1962). Acetoacetate can enter the blood stream as itself, but it can also undergo reactions to form two other ketone bodies called beta-hydroxybutyrate and acetone (Lopes-Carodoso et al., 1975). All three ketones enter the blood stream, acetone travels to the kidneys to be expelled in urine and the former two travel to the muscle cell (Hird & Symons, 1962). Inside the muscle cell, the ketone

bodies are converted into acCoA to be used in the Krebs's cycle to produce ATP, depicted in Figure 8.

If the ketone bodies are produced faster than they are catabolized or taken up by the muscle cells, they begin to accumulate in the blood stream (to bring the blood pH below 7.2) and ketoacidosis occurs (Fery & Balasse, 1985). An individual with ketoacidosis may feel thirsty and/or nauseous, have abdominal pain, display frequent urination and have acetone breath (sweet, fruit-like smelling breath) (Chiasson et al., 2003). Ketone bodies are strong acids and their accumulation can disrupt any physiological function ultimately leading to death if untreated (Chiasson et al., 2003). Ketoacidosis can be treated with intravenous insulin administration (Chiasson et al., 2003).

### ***Neuropathy***

Neuropathy is a disorder arising from nerve damage (Canadian Diabetes Association, 2008). There are four types of diabetic neuropathies: peripheral (affects legs, feet, toes, arms, hands and fingers), autonomic (affects heart rate, blood pressure, perspiration, and digestive, bowel, bladder and sexual function), proximal (affects thighs, hips and buttocks) and focal (affects a single nerve or group of nerves causing localized muscle weakness) (National Institute of Diabetes and Digestive and Kidney Diseases, 2009). Peripheral neuropathy is the most common type of neuropathy in DM and the popular sites of nerve damage are the ulnar, peroneal (fibular) and tibial nerves which lead to loss of sensation and uncomfortable pain in the wrists and feet (Dyck & Thomas, 1999; National Institute of Neurological Disorders and Stroke, 2008). Neuropathy takes

several years to develop and it is a condition with many pathologies and etiologies (Vinik, Strotmeyer, Nakave, & Patel, 2008). With respect to the diabetic population, it is believed that neuropathy is caused by hyperglycemia and dyslipidemia (Vinik et al., 2008). Hyperglycemia and dyslipidemia cause peripheral arterial disease (PAD), which itself is a complication of DM (and will be discussed below in **Peripheral Arterial Disease (PAD)**), but one which reduces blood flow and increases hypoxia (lack of oxygen) to the nerves causing damage (Vinik et al., 2008). There is no true treatment for neuropathy, but affected individuals can wear properly fitted shoes and take analgesics to reduce pain (National Institute of Neurological Disorders and Stroke, 2008).

### *Nephropathy*

Nephropathy is the term used to describe kidney disease (Canadian Diabetes Association, 2008). Kidney disease describes a collection of pathologies that prevent the kidney from performing its filtering and blood pressure regulation functions causing wastes and excess fluids to remain in the body (The Kidney Foundation of Canada, 2009c). Almost half of all individuals with nephropathy also have DM (Canadian Diabetes Association, 2008). Although kidney disease has many causes, glomerulosclerosis (thickening of the tiny blood vessel walls of the kidney) is the most common cause in DM (Kalant, 1978). In a normal kidney, blood filtering occurs in the glomerulus (a collection of capillaries) where blood pressure (BP) forces water and small molecules out of the capillaries, into the nephron tubule and out of the kidneys as urine, leaving larger and much needed molecules such as red blood cells and protein to continue circulating throughout the blood (Campbell et al., 2009). Glomerulosclerosis causes damage to the blood vessel walls and allows for the large proteins to be forced out of the

capillaries and into the nephron and it compromises waste filtering (Kalant, 1978). Along with compromised waste filtering, there is poor resting arterial BP regulation because the kidney damage creates a situation where excess water that is to be expelled as urine re-enters blood circulation (Kalant, 1978). The first indication of kidney disease is proteinuria (excess protein in the urine >30mg/day) (Canadian Diabetes Association, 2008). The damage and thickening of the vessel walls in the glomerulosclerotic condition is associated with hyperglycemia (Kalant, 1978). The increase in vessel wall thickening is proportionate to increases in blood glucose concentration (Kalant 1978).

Treatment options for kidney disease include dialysis and transplantation. With dialysis, a machine withdraws blood from the body and passes it through a dialyzer (an artificial kidney) (The Kidney Foundation of Canada, 2009a). The dialyzer contains dialysis fluid that is responsible for removing waste products from the blood (The Kidney Foundation of Canada, 2009a). A day dialysis treatment session can take up to 5 hours and most individuals receive 3 treatments per week (The Kidney Foundation of Canada, 2009a). Nocturnal dialysis treatments (offered separately from day dialysis treatments) take place while the individual is asleep and there are usually 6-7 treatment sessions each week (Pierratos, 1999). The second treatment option for kidney disease is transplantation. Transplantation involves removing affected kidneys and replacing them with healthy kidneys from either a live or recently deceased donor. Kidney transplants have a success rate of 85-95% (The Kidney Foundation of Canada, 2009b).

## ***Endothelial Dysfunction***

In DM, it is thought that hyperglycemia and dyslipidemia contribute to the dysfunction of the vascular endothelium (Canadian Diabetes Association, 2008). The endothelium is a type of simple squamous epithelium that lines the heart and blood vessels. The endothelium functions to regulate vascular tone (the degree to which a blood vessel is vasoconstricted or vasodilated), control thrombogenic processes (prevent the formation of blood clots and influence the degradation of them) and control inflammatory processes (such as platelet adhesion to blood vessel walls) (Ehrman, Gordon, Visich, & Keteyian, 2009). In a healthy endothelial cell, nitric oxide is produced and transported into vascular smooth muscle cells (VSMC) where it acts as the prominent agent for vasodilation, depicted in Figure 9. The process of nitric oxide formation begins with a receptor located on the endothelial cell membrane (Boger et al., 1998). The receptor is coupled with acetylcholine, bradykinin or acted upon by shear stress (from increased blood flow) and this stimulates an increase of calcium in the cytosolic space (Hayden & Tyagi, 2002). The increase in calcium activates the enzyme nitric oxide synthase (eNOS) which reacts with oxygen and this action allows for the co-factor tetrahydrobiopterin to couple another co-factor, nicotinamide adenine dinucleotide, to L-arginine to form nitric oxide and L-citrulline (see Figure 10) (Boger et al., 1998). The effects of nitric oxide are counterbalanced by the production and release of vasoconstricting substances, the most powerful one of which is endothelin 1 (ET-I) (Morris & Jardine, 2000). ET-I acts on VSMC to induce vasoconstriction via endothelin A receptor activation. In contrast, it also acts as a negative feedback mechanism by

stimulating endothelin B receptors and triggering the release of nitric oxide (Morris & Jardine, 2000).

Endothelial dysfunction occurs when there are alterations in the expression and/or release of vasoactive, anti-growth, anti-inflammatory and/or anti-thrombotic substances (Faulx, Wright, & Hoit, 2003), thus preventing the endothelium from properly carrying out its function (Avogaro, Fadini, Gallo, Pagnin & de Kreutzenberg, 2006). In DM and other cardiovascular diseases, endothelial dysfunction is believed to occur as a result of reduced nitric oxide bioavailability, increased reactive oxygen species (ROS; highly reactive oxygen ions that can damage cell structures) and/or atherogenesis (formation of fatty deposits on the inner lining of the arteries) (Ding & Triggle, 2005). With respect to the former, potential causes of reduced bioavailability include 1) reduced L-arginine concentrations, 2) the down-regulation of eNOS, 3) impaired eNOS activation, and 4) increased oxidative stress/ROS-induced nitric oxide degradation (discussed below) (Faulx et al., 2003).

In addition, hyperglycemia and dyslipidemia cause an increase in protein arginine N-methyltransferase activity (Nash, 2002). Protein arginine N-methyltransferase is the enzyme responsible for the formation of asymmetrical dimethylarginine (ADMA). ADMA is an inhibitor of L-arginine (Nash, 2002). With L-arginine deficiency, the nicotinamide adenine dinucleotide reacts with oxygen instead of the L-arginine and a superoxide, instead of nitric oxide, is produced (Hayden & Tyagi, 2002). This form of dysfunction has the endothelial cell producing less nitric oxide and in turn decreases vasodilation and blood flow, and increases vasoconstriction and blood pressure (Boger et al., 1998). Also, the formation of superoxides instead of nitric oxide is detrimental to all

cells because superoxides react with transition metals (i.e., iron) to form hydrogen peroxide and then a hydroxyl radical, or they react with nitric oxide (formed in a separate cell) to form peroxynitrite (see Figure 11) (Beckman & Koppenol, 1996; Turrens, 2003). The hydroxyl radical and peroxynitrite are known as (ROS) and they react with nucleic acids and proteins altering their functions and contributing to endothelial dysfunction (Beckman & Koppenol, 1996).

Endothelial dysfunction can also be caused by diabetic dyslipidemia itself. Diabetic dyslipidemia increases the risk of developing atherosclerosis (fatty deposits on the inner lining of the arteries) by three-fold (Kannel & McGee, 1979). In the diabetic dyslipidemic condition, readily available and over abundant LDLs are taken up by the endothelial cells where they are acted upon by ROS and the enzymes sphingomyelinase, secretory phospholipase and myeloperoxidase to create oxidized LDLs which are pro-inflammatory lipids that attract certain monocytes (white blood cells) called macrophages (Rose & Afanasyeva, 2003; Rader & Daugherty, 2008). The macrophages take in oxidized LDLs through the scavenger receptors CD36 and SR-A to form lipid-laden foam cells (see Figure 12) (Rader & Daugherty, 2008). The foam cells migrate to the endothelial wall where they create a pro-inflammatory environment by producing cytokines that signal intimal (endothelial lining of the blood vessel or lumen) proliferation and the production of myeloperoxidase, an enzyme that produces ROS, which leads to more foam cell production and further endothelial damage (as ROS disrupt nucleic acids and proteins) (Rader & Daugherty, 2008). The foam cells also collect cholesterol and platelets, and can develop into a lesion or plaque that narrows the



lumen and contributes to endothelial dysfunction, hypertension and/or reduced blood flow (Rader & Daugherty, 2008).

Endothelial cell damage and the resultant dysfunction is thought to be a major contributor to the development and progression of cardiovascular disease (Ehrman et al., 2009). The term cardiovascular disease encompasses several disease states that affect the heart or blood vessels, such as coronary artery disease (including atherosclerosis (thickening of arterial walls due to fatty deposits), angina and myocardial infarction), hypertension, PAD (including atherosclerosis), rheumatic heart disease (damage to the heart muscle and heart valves caused by bacteria), congenital heart disease (malformations of the heart present at birth) and heart failure (World Health Organization, 2009b). The first, coronary artery disease is often used interchangeably with the term cardiovascular disease and/or atherosclerosis, as not only is it the most prominent form of cardiovascular disease, atherosclerosis predominantly occurs in the coronary arteries (World Health Organization, 2009b). When the atherosclerosis occurs in the arteries leading to the brain it is referred to as either carotid artery disease or cerebrovascular disease, depending on the location of the atherosclerosis, and finally as PAD when referring to the arteries outside of the heart and brain (American Heart Association, 2008b). Atherosclerosis is the leading cause of cardiovascular disease (Canadian Diabetes Association, 2008).

### ***Hypertension***

Hypertension, characterized by a sustained elevation in resting BP that is equal to or above 140 mmHg(systolic) and/or 90 (diastolic) mmHg, affects most individuals with

diabetes (Canadian Diabetes Association, 2008). Systolic BP represents the pressure acting against the arterial walls as blood is ejected from the heart and its contracting ventricles, while diastolic BP represents the pressure acting against arterial walls when the heart's ventricles are relaxing and filling with blood (Powers & Howley, 2009). As previously discussed, one cause of hypertension in diabetics is the loss of regular kidney function which regulates BP (Kalant, 1978). As BP is dependent on volume, the accumulated, excess water re-enters the circulation and increases BP (Kalant, 1978). The pressure increase also influences the progression of kidney disease because it causes more force to be exerted on blood vessel walls which contributes to their damage (Kalant, 1978). When the blood vessels of the kidneys are damaged, the kidneys cannot function properly and their pathology progresses at a faster rate (Kalant, 1978).

Resting BP is also dependent on vascular resistance (resistance to blood flow provided by blood vessels). In the diabetic condition, increased vasoconstriction is caused by increased levels of the enzyme protein kinase C due to hyperglycemia (Koya & King, 1998). An individual with hyperglycemia will still exhibit glucose uptake by cells using the glucose transporter proteins (Klip & Paquet, 1999), yet it is not sufficient enough to reduce blood glucose levels. It is, however, sufficient enough to increase levels of protein kinase C (Koya & King, 1998). Glucose enters the cell and is converted into dihydroxyacetone phosphate (DHAP) via glycolysis (Koya & King, 1998). DHAP is acted on by the enzyme glycerol-3-phosphate dehydrogenase to form glycerol-3-phosphate (Koya & King, 1998). Glycerol-3-phosphate goes through a series of reactions to form diacylglycerol (see Figure 13) (Yoshimura, Oshima, & Ogasawara, 2007). After 3-5 days of hyperglycemia, there is a noticeable and significant increase in diacylglycerol

concentration (Koya & King, 1998). Diacylglycerol activates protein kinase C which is responsible for increased calcium responsiveness in smooth muscle contraction (vasoconstriction) (see Figure 14) and increased smooth muscle contraction itself (Koya & King, 1998).

Another probable cause of increased vascular resistance in the diabetic condition is smooth muscle cell proliferation due to increased mitogen-activated protein kinase (MAPK) activation (Bruemmer, 2006). Hyperinsulinemia (in T2D) causes increased MAPK activity (Bruemmer, 2006). In the healthy condition, insulin binds to the insulin receptor on the cell membrane and the phosphatidylinositol-3 kinase (see *Negative Feedback and Blood Glucose Regulation Mechanisms*) pathway is activated (Robinson & Buse, 2008). In an individual with T2D, the phosphatidylinositol-3 kinase pathway is inhibited and instead the MAPK pathway is activated (see Figure 15) (Bruemmer, 2006). The insulin binds to the insulin receptor and this action causes the activation of the enzyme tyrosine kinase which phosphorylates insulin receptor substrate proteins (Robinson & Buse, 2008). The activated insulin receptor substrate proteins then bind to the Src homology 2 protein and the two proteins interact with another protein (growth factor receptor bound protein 2) and all three proteins bind to the Ras guanylnucleotide exchange factor son of sevenless to create a protein complex (Kusari, Byon, Bandyopadhyay, Kenner, & Kusari, 1997). The activated protein complex removes guanosine diphosphate from Ras, after which Ras binds to guanosine triphosphate and becomes activated (Kusari et al., 1997). Activated Ras activates Raf protein kinase which activates mitogen-activated protein kinase kinase, after which MAPK is then activated (Kusari et al., 1997). MAPK is responsible for smooth muscle cell

proliferation (Bruemmer, 2006). Increased smooth muscle cell mass increases vascular resistance because more cells are available to induce vasoconstriction (Koya & King, 1998).

The adoption of a healthy lifestyle, including weight loss strategies, sodium restriction and regular physical activity, is an integral component of hypertension treatment and management in DM. A decrease of 1 kilogram in body weight has been proven to decrease mean BP (calculated as  $[\text{resting diastolic BP} + 0.33 \times (\text{systolic BP} - \text{diastolic BP})]$ ) by 1 mmHg. Furthermore, reductions in dietary sodium intake to less than 2300 mg per day is associated with systolic BP and diastolic BP reductions of 5 mmHg and 3 mmHg, respectively. (American Diabetes Association, 2002)

For many individuals, pharmacological therapy is required in addition to lifestyle modifications to reduce resting BP to values within the target range. Drug therapy for individuals with DM and hypertension includes a combination of angiotensin converting enzyme (ACE) inhibitors, beta-blockers, calcium channel blockers and diuretics. (Canadian Diabetes Association, 2008)

### **1.1.5 Recommendations for the Treatment of DM**

#### ***Exercise***

Exercise training is a non-pharmacological, non-surgical treatment recommended for DM (American College of Sports Medicine, 2010). Exercise, and thus the components of an exercise training program, can be aerobic or anaerobic in nature.

Exercise is considered aerobic when performed at  $\leq 70\%$  of maximum heart rate (Connors, Grymkowski, Kimber, & Reynolds, 1992). Aerobic exercise uses both carbohydrates and fats as a fuel source (Powers & Howley, 2009), and ATP is created via the Krebs's cycle (see Figure 3) and the electron transport system (see Figure 4).

In general, anaerobic exercise is performed at an intensity of  $\geq 75\%$  of an individual's maximum heart rate (Connors et al., 1992), and ATP is produced from glycolysis (see Figure 2) and the phosphagen energy system (see Figure 16) in the absence of oxygen (Connors et al., 1992). Although resistance exercise is classified as a type of anaerobic exercise, it applies a force of resistance against the force of contraction (Conner et al., 1992), and is, as such, not driven by maximal heart rate. There are three different types of resistance exercises: concentric (shortening of muscle fibers due to greater muscle force than resistance force), eccentric (lengthening of muscle fibers due to greater resistance force than muscle force) and isometric (no change in fiber length due to the resistance force and muscle force equaling one another) (Heyward, 2006; Hamill & Knutzen, 2003). Isometric exercise is often distinguished separately from concentric and eccentric resistance exercise because of its unique resistance force and lack of fiber length change.

In general, both aerobic and anaerobic exercise training regimens have shown to improve tissue insulin sensitivity (how well muscle cells respond to insulin) in those with DM (Winnick et al., 2008; Jimenez, Santiago, Sitler, Boden, & Homko, 2009).

### ***Improved insulin sensitivity***

Although T1D is characterized by insulin inavailability, sensitivity to existing insulin is increased with chronic, but not acute, exercise exposure in this population. For example, Jimenez and colleagues (2009) saw no change in pre- to post-exercise insulin sensitivity in adults with T1D (n=14) who performed 5 sets of 6 repetitions of a resistance leg exercise at 80% of 1 repetition maximum (Jimenez et al., 2009). In contrast, 12 weeks of aerobic exercise training (3 times per week for 45 minutes) at 80-75% maximum heart rate intensity increased insulin sensitivity by 25+/- 5% in children (n=15) with T1D (Landt, Campaigne, James, & Sperling, 1985).

Individuals with T2D have a lower insulin sensitivity than their T1D counterparts (Weir & Bonner-Weir, 2004) and their reaction to exercise differs as well. The positive effect of exercise on insulin sensitivity in T2D is noticeable after both acute and chronic exercise. In a population of T2D (n=9), a single bout of exercise performed for 15 minutes at anaerobic threshold intensity can increase glucose infusion rate (an index of insulin sensitivity) by 3.2+/-0.8 mg/kg/min (Oguri, Adachi, Ohno, Oshima, & Kurabayashi, 2009) immediately post-exercise. These findings were further supported by Winnick and colleagues (2008) who observed increases in whole-body insulin sensitivity after one week of exercise. Specifically, 18 obese T2D individuals performed 50 minutes of treadmill aerobic walking (at 70% of maximal oxygen uptake) everyday for 7 days, and post-training increases in glucose infusion rates of 0.2+/- 0.3 mm/kg/min were noted (Winnick et al., 2008).

The exercise data on GD and insulin sensitivity and resistance are limited and equivocal. With respect to the effect of acute exercise, a study conducted by Garcia-Patterson and colleagues (2006) examining 20 non-exercise trained women with GD who performed a self-paced flat surface walking bout for 1 hour found decreases ( $0.7 \pm 0.9$  mM) in 1 hour postprandial blood glucose, when the women served as their own controls the day prior (Garcia-Patterson et al., 2006). A second study (n=33) comparing women with GD who exercise trained (30 minutes, 4 days per week, 12 weeks, 70% maximal oxygen uptake) to those who were sedentary observed no differences in insulin sensitivity, insulin resistance or blood glucose concentration between the two groups (Avery, Leon, & Kopher, 1997). The authors did, however, report modest, but not statistically significant, increases in cardiovascular fitness.

Aerobic and anaerobic (including resistance) exercise not only increases insulin sensitivity and improves insulin resistance in T1D, T2D and GD, evidence suggests that individuals with T2D will exhibit improvements in GLUT4-driven glucose regulation with exercise (Kennedy et al., 1999).

### ***Improved blood glucose regulation in T2D: GLUT4s and their translocation***

As previously discussed, glucose transporter proteins (GLUT4s) are needed for the uptake of glucose by the muscle cells (Klip & Paquet, 1999). GLUT4 translocation can be insulin-stimulated, but it can also be contraction (or exercise) stimulated (Hardie, 2002). Acute aerobic exercise (one session of cycling at 60-70% maximal oxygen uptake for 45-60 minutes) performed by adults with T2D elicited a 77% increase in membrane GLUT4 when compared to the resting condition (Kennedy et al., 1999).

Exercise-induced increases in GLUT4 have also been noted in individuals with T2D following resistance exercise training. Holten and colleagues (2004) examined 10 individuals with T2D who served as their own control for a resistance exercise study. Participants completed 3 different unilateral leg exercises (3 sets, 8-12 repetitions at 70-80% of 3 repetition maximum), 3 times per week for 6 weeks (Holten et al., 2004). After the intervention, GLUT4 density was increased by approximately 40% in the trained legs when compared to the untrained (control) legs (Holten et al., 2004). The trained legs also displayed an increase in thigh circumference (52.5 $\pm$ 1.5 cm to 54.3 $\pm$ 1.9 cm) and muscle fiber diameter (5.4 $\pm$ 1.7%) (Holten et al., 2004).

The contraction-stimulated GLUT4 translocation mechanism follows a different pathway than that of the insulin-stimulated GLUT4 translocation (Kruth-Kraczek, Hirshman, Goodyear, & Windder, 1999). The insulin-stimulated pathway involves the insulin receptor and protein kinase B, while the contraction-stimulated pathway involves adenosine monophosphate-activated protein kinase (AMPK) (Robinson & Buse, 2008; Kruth-Kraczek et al., 1999).

Exercise (aerobic and anaerobic) causes a change in the cellular energy status recognized by an increase in adenosine monophosphate concentration due to the breakdown of the fuel adenosine triphosphate (Kruth-Kraczek et al., 1999). The increase in adenosine monophosphate activates AMPK B which phosphorylates the protein AS160, which is responsible for converting the Rab protein into its inactive form of guanosine diphosphate and inhibiting GLUT4 movement, and dissociates it from GLUT4 located inside the muscle cell (Hardie, 2002). Once dissociated, AS160 no longer promotes the Rab-guanosine diphosphate conversion and the Rab gets converted into its



active form, guanosine triphosphate which causes the translocation GLUT4 to the cell membrane (see Figure 17) (Klip & Paquet, 1999; Hardie, 2002). Although the activating mechanisms for GLUT4 translocation differ between insulin-stimulated and contraction-stimulated situations, both pathways dissociate AS160 from GLUT4 allowing it to be transported to the membrane (Hardie, 2002; Klip & Paquet, 1999). The increase in GLUT4s increases glucose uptake by the muscle cells and this reduces the elevated blood glucose concentration in T2D reducing the extent of hyperglycemia and its effects (decreased nitric oxide production and increased ROS production) (Klip & Paquet 1999).

### ***Exercise Recommendations***

In light of the above-described benefits of exercise in those with DM, exercise is a highly recommended treatment option, particularly for those with T2D. The gold standard exercise prescription guidelines, endorsed by the American College of Sports Medicine, recommend 20 to 60 minutes (which can be divided into 10 minute bouts for a total of 150 minutes per week) of dynamic aerobic activity at 50-75% of maximum heart rate, 3 to 7 times per week, supplemented with light weight training 2 to 4 days per week. The aerobic activity can include walking, running, swimming or cycling, for example, and light weight training refers to resistance training focusing on larger muscle groups with weights ranging between 60-80% of 1 repetition maximum for at least 2 sets of 8-12 repetitions. (American College of Sports Medicine, 2010)

### ***Pharmacological Treatment Options for DM***

Those with T1D require exogenous insulin daily to control blood glucose concentration (Berg, 1986). This exogenous insulin is synthetically engineered and

produced, and can be injected into the body using a syringe (a needle and vial system), an insulin pen (pre-filled with insulin and dosage-controlled via a dial) or an insulin pump (delivers short-acting insulin throughout the day using a catheter placed under the skin) (Canadian Diabetes Association, 2008).

Individuals with T2D can treat or control their decreased insulin sensitivity with the use of oral medications. Thiazolidinediones and biguanides increase the body's insulin sensitivity. Sulfonylureas and meglitinides stimulate the pancreas to synthesize more insulin. These drugs, in turn, help lower blood glucose, and some can be combined to elicit a greater response, but the risk of side effects increases with their combination (Canadian Diabetes Association, 2008).

Expectant mothers with GD, when necessary, can be prescribed insulin for injection without harming the fetus (Canadian Diabetes Association, 2009).

## **1.2 Peripheral Arterial Disease in DM**

### **1.2.1 Peripheral Arterial Disease (PAD)**

As previously discussed, peripheral arterial disease (PAD) is a common complication of DM and is characterized by structural changes (such as inflammation or tissue damage) in the blood vessels outside of the heart and brain, and these changes cause reduced blood flow to the tissues (American Heart Association, 2009b). The most common symptom of PAD is intermittent claudication which is described as pain or

cramping in the muscles of the lower extremities brought on by walking and relieved by rest, yet some diabetics are asymptomatic due to their neuropathy-induced loss of sensation (American Diabetes Association, 2003). PAD affects individuals with DM mainly in the popliteal and tibial arteries (below the knee) (American Diabetes Association, 2003). DM-associated hyperglycemia and dyslipidemia are two main causes of PAD (American Diabetes Association, 2003). PAD is also an underlying cause of other diabetic conditions such as neuropathy and nephropathy (Kalant, 1978; Vinik et al., 2008).

### **1.2.2 Methods of Assessing PAD**

There are many ways to measure and assess PAD, including the most widely employed methods of angiography, ankle-brachial index and duplex ultrasound.

Catheter angiography, also known as conventional angiography, is a minimally invasive test and the gold standard for PAD assessments (Radiological Society of North America, 2010; Clifton, 2000). A catheter containing a contrast dye is inserted into an artery through an incision in the skin after which the artery undergoes an x-ray (Radiological Society of North America, 2010; Clifton, 2000). Catheter angiography is the most accurate form of PAD assessment; however, it is associated with several risks such as infections and kidney damage (Radiological Society of North America, 2010).

Phased-contrast magnetic resonance angiography non-invasively assesses PAD. Various magnetic fields are applied to the limb or body part in question. Several images are acquired and a mathematical pixel by pixel calculation is applied to phase out static

tissues (muscle and bone) leaving only the flowing blood visible on the final image. Similar to catheter angiography the final image can be used to detect arterial narrowings and malformations, but unlike the gold standard method, phased-contrast angiography can also measure blood flow. However, this method of assessment is time consuming and adversely affected by slight movements made by the individual undergoing the angiography. (Clifton, 2000)

The ankle-brachial index (ABI) is another non-invasive test used to assess PAD, and involves the measurement of ankle systolic BP (using dorsalis pedis and posterior tibial arteries) and arm systolic BP (using the brachial artery) to ultimately evaluate the patency of the arteries of the lower extremities (Bernstein & Fronek, 1982). Specifically, a ratio (ABI) between the ankle and arm is determined from the measured systolic BPs (e.g., ankle systolic BP/ brachial artery BP) (Bernstein & Fronek, 1982). For the calculation, the greater value of the two brachial pressures is used, and both ankle pressures (on each leg) are used to give a total of 4 ABIs per individual (Bernstein & Fronek, 1982). A normal, non-diseased lower extremity artery will have an  $ABI \geq 0.90$  while a diseased artery will have an  $ABI < 0.90$  (Carbayo et al., 2007). To further classify PAD, an ABI of 0.70-0.89 suggests a mild obstruction in the artery, 0.40-0.69 suggests a moderate obstruction, and  $< 0.40$  suggests a severe obstruction (American Diabetes Association, 2004d). The ABI test has been validated against angiographically confirmed disease (accuracy range: 95-100%) (Bernstein & Fronek, 1982). One limitation of the ABI is the influence of poorly compressible and calcified vessels. In such instances, BP measurements cannot be obtained as a result of the arteries' inability to occlude, leading to artefactually elevated ABIs of  $> 1.30$  (Bernstein & Fronek, 1982).

Another limitation is that aortoiliac stenoses (abnormal narrowing of the aorta or iliac arteries) can reduce BP in the lower extremity (and in turn reduce the ABI) causing the false belief that the PAD is solely in the lower extremity (American Diabetes Association, 2004). Even with these limitations, ABI is a highly used, popular and proven non-invasive method of PAD assessment in clinical settings (American Diabetes Association, 2004).

Another method of assessing PAD is duplex ultrasound which uses a combination of two techniques to obtain arterial images and determine the degree of the disease (Scottish Intercollegiate Guidelines Network, 2006). Images are acquired through both B-mode ultrasound (using sound frequencies to produce an arterial image) and Doppler ultrasound (using reflected sound waves to generate an image of blood flow direction and velocity) and assessed together (Scottish Intercollegiate Guidelines Network, 2006). B-mode ultrasound provides a visual image of arterial narrowings, while Doppler ultrasound uses blood flow and velocity to determine the amount (in percent) of anatomical narrowing (Sensier et al., 1996). Duplex ultrasound has been proven to 92-99% accuracy when compared to angiography (Aly et al., 1998).

In addition to the assessment of PAD itself, the symptoms of the disease can be evaluated. A common practice is the assessment of intermittent claudication using a graded-exercise treadmill test (Gardner, Skinner, Cantwell, & Smith, 1999). There are different protocols for the graded-treadmill test, a popular one of which is the Gardner protocol (Gardner et al., 1999). Using the Gardner protocol, individuals walk on the treadmill at a constant 2 mph, beginning at 0% grade, with a 2% increase in grade every 2 minutes to a maximum of 14 % (completing the 2 minutes at 14% for a maximum total of

16 minutes on the treadmill) (Gardner et al., 1999). During the graded-exercise treadmill test, the distance at which the individual first notices claudication pain is recorded and this is referred to as the initial claudication distance (ICD) (Hiatt, Nawaz, Regensteiner, & Hossack, 1998). The absolute claudication distance (ACD), the distance at which the individual reaches maximal claudication pain causing the termination of the test, is also recorded (Hiatt et al., 1998). The graded-exercise treadmill test is used clinically across all age groups and disease states and has a within-subject variation of 15-25% for the ICD and 12-13% for the ACD (Hiatt et al., 1998). This test is superior to the previously popular constant-load treadmill test, where individuals walk at 2 mph at a constant grade of any value between 0% and 12% for a maximum of 5 minutes, which has a within-subjects variation of 30% for the ICD and 45% for the ACD (Gardner et al., 1999). Increases in ICD and ACD with repeated graded-exercise treadmill tests correlate with improved ambulatory function (Hiatt, Regensteiner, Hargarten, Wolfel, & Brass, 1990).

### **1.2.3 Treatment recommendations for PAD**

The most effective treatment and control methods for PAD are of the surgical nature, but medications and physical activity can control the prominent risk factors of PAD (i.e., hypertension and dyslipidemia) and slow or halt the progression of the disease as well (American Heart Association, 2009a).

## *Chronic Exercise and PAD in DM: A Closer Look*

### *Aerobic exercise training*

Although aerobic exercise bouts can be painful to individuals with PAD due to claudication effects (Gardner & Montgomery, 2008), aerobic exercise training can improve walking time and distance and delay the onset of claudication signifying a halt in the progression of the disease (Imparato, Kim, Davidson, & Crowley, 1975). For example, Hiatt and colleagues (1994) demonstrated that a 12 week treadmill training program (3 hours per week at an intensity sufficient to produce claudication) increased maximal walking time by approximately 74% in individuals with PAD. An additional 12 weeks, using the same individuals performing the same exercise program, increased their maximal walking time by approximately another 49% (Hiatt, Wolfel, Meier, & Regensteiner, 1994). Upper extremity aerobic training programs appear to increase ambulatory function as well by improving maximal walking distance. For example, Treat-Jacobson and colleagues (2009) investigated 41 individuals with PAD (15 of whom had DM) performing supervised arm-ergometry exercises, treadmill walking or both for 12 weeks (3 hours per week). Findings suggested that arm-ergometry performed for 60 minutes (cycles of 2 minute cycling at 10 watts below maximum ability, followed by a 2 minute rest period) increased maximal walking distance by approximately 53% (Treat-Jacobson, Bronas, & Leon, 2009). Furthermore, treadmill walking for 60 minutes (cycles of 2 mph walking until claudication, followed by rest until pain relief) and a combination of both exercise programs increased maximal walking distance by 69% and 68%, respectively (Treat-Jacobson et al., 2009). Another study further supported these findings by concluding that after 24 weeks of bi-weekly upper and lower extremity aerobic

exercises (85-90% maximal oxygen uptake) individually increased maximal walking distance by approximately 30% (Zwierska et al., 2005).

### ***Resistance exercise training***

In addition to delaying the onset of claudication, individuals with PAD who undergo a resistance training program can reap muscular strength and aerobic endurance benefits. For example, Wang and colleagues (2009) implemented a maximal lower leg specific strength training program in individuals with PAD, whereby participants performed 4 sets of 5 repetitions (85-90% of 1 repetition maximum) on a leg press 3 times per week for 8 weeks (Wang et al., 2009). The participants increased their muscular strength, as evidenced by an increase in their 1 repetition maximum by approximately 31% (Wang et al., 2009). Walking economy (the rate at which oxygen is consumed during a walking session) increased by approximately 9.7% (Wang et al., 2009). Other studies using lower extremity resistance exercise training in PAD also found increases in ACD (increased approximately 36%) and maximal walking time (increased approximately 49%) (Hiatt et al., 1994; McDermott et al., 2009), as well as stair climbing endurance (increased approximately 15.0 points on a physical functioning test) (McDermott et al., 2009).

### ***Effects of aerobic and resistance exercise training on the pathophysiology of PAD***

PAD is, once again, the structural changes in arterial walls (usually inflammation) (American Heart Association, 2008b) influenced by dyslipidemia and characterized by endothelial dysfunction (American Heart Association, 2008a). The lack of progression of



PAD during an exercise regimen could be attributed to an alteration of an individual's lipid profile and improved endothelial function and vasodilation.

Aerobic and resistance exercise lowers triglyceride levels through a process known as lipolysis by breaking down triglycerides into free fatty acids that can be used for fuel. Lipolysis is activated with increased sympathetic nervous system (a branch of the autonomic nervous system that increases its activity during exercise and stress) stimulation which in turn promotes the release of norepinephrine which stimulates receptors on adipose and/or skeletal muscle tissue. The binding of norepinephrine to these receptors activates the enzyme adenylyl cyclase which converts adenosine triphosphate into the cyclic adenosine monophosphate that is responsible for activating protein kinase A. Activated protein kinase A phosphorylates hormone sensitive lipase which acts on triacylglycerol (triglyceride). A series of lipase reactions occur and the compound which was once triacylglycerol is now a glycerol molecule and three free fatty acid molecules (see Figure 18). The lipolysis causes the triglyceride levels to decrease and creates fuels that can be used for energy. (Large & Arner, 1998; Lafontan et al., 2008)

The lowered triglyceride levels cause an increase in HDL activity which is already initially increased due to exercise (Dishman, Washburn, & Heath, 2004). Exercise is known to increase the activity of the enzyme that works in conjunction with HDL, lecithin cholesterol acyl transferase (LCAT) (Dishman et al., 2004). HDL is created when apolipoprotein A1 (APOA-1) binds with phospholipids (from membranes) and cholesterol (from diet) that have exited a cell using a protein transporter called adenosine triphosphate-binding cassette transporter (ABC) (it relies on energy from

adenosine triphosphate to work) (Ikonen, 2008). This HDL is acted on by LCAT, from the interstitial space, which esterifies the cholesterol to form globular (sphere-shaped) HDL (Ikonen, 2008). The globular HDL accepts and esterifies cholesterol from other tissues, arterial walls and LDLs with the help of LCAT (Ikonen, 2008). The globular HDL can travel to liver cells or steroidogenic cells where the esterified cholesterol is removed using a scavenger receptor and then excreted as bile or used in hormone synthesis (see Figure 19) (Ikonen, 2008). As exercise increases LCAT activity, HDL production and activity increase and LDL levels decrease (Borer, 2003).

The exercise-induced improvements in PAD and endothelial function are thought to occur primarily through increased nitric oxide production (Sessa, Pritchard, Seyedi, Wang, & Hintze, 1994) via a shear stress mechanism (Hambrecht et al., 1998; Sessa et al., 1994), yet changes in resistance vessel structure and/or improved sensitivity of the peripheral vasculature cannot be ruled out. During aerobic exercise, cardiac output (product of heart rate and stroke volume) increases approximately 4-fold in order to meet the blood and oxygen demands of the working muscles, and this causes repeated episodes of vascular wall shear stress (Sessa et al., 1994). The mechanical shear stress of blood (along with acetylcholine and bradykinin) is a stimulus (Hayden & Tyagi, 2002) that acts on endothelial cell receptors triggering an increase in cytosolic calcium which activates the eNOS to produce nitric oxide (Borer et al., 1998; Grijalva et al., 2008). Resistance exercise also increases the amount of blood circulating to the muscle tissue causing an increase in shear force and thus an improvement in endothelial dysfunction (Sessa et al., 1994).

### *Isometric exercise training*

To date, no studies have examined the chronic effects of isometric exercise on ICD, ACD and blood flow in individuals with PAD. However, as PAD is characterized by intermittent claudication and the subsequent decrease in blood flow, studies examining blood flow and endothelial function (including vasodilation) with isometric exercise training are applicable to this clinical population. Blood flow is determined by the product of  $(\pi r^2)v$ , ('r' refers to the radius of the blood vessel, 'v' refers to the velocity of the blood), and thus an increase in blood vessel radius (such as vasodilatory ability) promotes an increase in blood flow.

Isometric exercise is novel form of exercise that is relatively under-investigated, especially in clinical populations. Although the effect of both acute and chronic lower extremity isometric exercise on blood flow is limited, studies have examined blood flow post-acute isometric exercise in the arm. Thompson and colleagues (2007) observed a change in blood flow immediately following one isometric hand grip (IHG) session performed until the participant could no longer sustain the force within 5% of the target value (20% MVC) for more than 2 seconds. The participants, male (n=18) and female (n=20), displayed an increase in brachial blood flow from approximately 2 ml/min/100ml to 6.7 ml/min/100ml and 7.4 ml/min/100ml, respectively (Thompson, Fadia, Pincivero, & Scheuermann, 2007). The findings supported the work of McGowan and colleagues (2006) who noted an increase in brachial artery blood flow immediately following an acute bout of 30% MVC IHG exercise in individuals with hypertension (n = 17; 4, 2-minute IHG contractions, each separated by a 4-minute rest period). An earlier study conducted by Lind & Williams (1979) found a positive linear relationship between IHG

intensity and forearm blood flow (2 seconds after the completion of the contraction) with 7 individuals performing the exercises at 20%, 40% and 60% MVC. The linear relationship no longer existed at intensities >60% MVC, therefore the authors concluded that high intensities were not beneficial for increasing blood flow (Lind & Williams, 1979).

Although, acute bouts of isometric exercise have shown to increase post-exercise blood flow, they have also been associated with attenuation in endothelium-dependent vasodilation (McGowan et al., 2006a). The increase in blood flow and subsequent decrease in endothelium-dependent vasodilation has also been shown to occur with chronic upper extremity isometric training as in another study conducted by McGowan and colleagues (2006) where IHG was performed 3 times per week for 8 weeks. Chronic upper extremity isometric exercise training is associated with an increase in resting vasodilatory capacity and post-exercise blood flow (McGowan et al., 2006a), however, when compared to an acute bout, neither the magnitude of the increase in post-exercise blood flow is augmented, nor the transient reduction in endothelium-dependent vasodilation is ameliorated.

The likely cause of reduced NO-mediated or endothelial-dependent arterial vasodilation is peroxynitrite formation from a reaction between NO and reactive oxygen species (ROS) (Li & Fostermann, 2000), which are created during ischemic conditions (Alessio et al., 2000) such as isometric exercise. This phenomenon of increased blood flow/decreased endothelial function could be due to an accumulation of metabolites, such as adenosine (Costa & Biaggioni, 1998), that cause the dilation of blood vessels in order

to decrease their local concentration (Herlihy, Bockman, Berne, & Rubio, 1976) thus not requiring endothelial-dependent vasodilation.

Bilateral lower extremity isometric training studies are few and limited. One study examined resting arterial blood pressure (BP) in 11 healthy individuals performing 4, 2 minute contractions at 30% maximum voluntary contraction 3 days per week for 8 weeks and found that resting systolic and diastolic BP were reduced by approximately 4 mmHg and 3 mmHg, respectively (Wiles, Coleman, & Swaine, 2009). However, during isometric exercise performance BP has been known to increase. Increases in BP with isometric exercise are dependent on both the size of the muscle employed and the intensity of the contraction, and heart rate increases are exercise and intensity dependent (Ray & Carrasco, 2000). As such, the BP and heart rate increases during acute isometric bilateral lower extremity exercise may be of a magnitude great enough to elicit larger increases in resting vasodilatory capacity via repetitive exposure to increased pulsatile blood flow (Ray & Carrasco, 2000; Taylor et al., 2003). Chronic exposure to this larger isometric stimulus (due to larger muscle mass), may elicit greater post-training improvements in resting endothelial function while concomitantly ameliorating or improving post-exercise endothelial dysfunction, as higher intensity upper extremity isometric training can significantly reduce the formation of exercise-induced ROS (Peters et al., 2006).

To add, acute isometric exercise bouts have been proven to significantly increase shear stress rate (a stimulus responsible for the metabolic cascade necessary for vasodilation and subsequent blood flow) from  $25.2 \pm 2.3 \text{ seconds}^{-1}$  (baseline) to  $41.9 \pm 5.2 \text{ seconds}^{-1}$  (McGowan et al., 2006b). Therefore, repeated bouts of bilateral isometric

exercise (training) could produce a larger and potentially longer lasting metabolic effect of shear stress, allowing for a delayed reduction in blood flow during aerobic exercise in a population with PAD and DM, more specifically, T2D. It is also possible that the larger blood vessels of the lower extremities may require more time for metabolite accumulation preventing or minimizing metabolite-aided vasodilation thus increasing the reliance on endothelium-dependent vasodilation and fostering improvements in endothelial dysfunction.

The increase in vasodilation and blood flow would allow individuals to exercise aerobically for longer and reap the benefits for their T2D and PAD treatment. Increased resting vasodilation would create a greater initial or pre-exercise blood flow potentially increasing the margin between sufficient and reduced blood flow during exercise. As reduced blood flow causes claudication, this would increase the time to claudication. Increased post-exercise blood flow could be an indicator of improvement in physiological processes responsible for defending against claudication. In this situation, isometric exercise training may act as a bridge to aerobic exercise.

### ***Pharmacological and Surgical Treatment Options for PAD***

There is no true pharmacological treatment method for PAD, however, the risk factors for PAD, hypertension and dyslipidemia, can be controlled or stabilized through the prescribed use of pharmaceutical drugs. Anti-platelet (e.g., acetylsalicylic acid), vasodilating (e.g., Cilostazol), cholesterol-reducing (e.g., Lipitor), and BP lowering medications (e.g. ACE inhibitors) are often prescribed to individuals with PAD to cease disease progression and aid in symptom remedy. (American Heart Association, 2009a)

Surgical treatments are recommended for individuals with extremely severe, debilitating, or aggressively progressing PAD. Angioplasty is a surgical procedure where a balloon is inflated in the artery and compresses the lesion against the arterial wall increasing the luminal space. A stent (wire mesh cylinder) can be inserted following angioplasty to help keep the artery open to the new luminal diameter created. If the PAD spans a large enough portion of the artery or completely impedes the artery's blood flow, then a bypass can be performed. A bypass consists of rerouting the blood flow around the blocked artery. A vein is taken from elsewhere in the body and used for this rerouting. An artificial artery (made from Gortex) can be used instead of a vein. (American Heart Association, 2009a)

### **1.3 Summary of Background**

DM affects almost 200 million people worldwide and decreases age-expectancy and increases the risk of cardiovascular disease (World Health Organization, 2008; World Health Organization, 2009b; Grundy et al., 2009). Approximately 95% of the population with DM are classified under the T2D sub-category (Berg, 1986) and suffer not only from the disease, but from its complications, such as PAD (Canadian Diabetes Association, 2008). Although not specific to DM populations, the weight of evidence suggests that exercise as an intervention can decrease the symptoms of PAD (e.g., claudication) (Zwierska et al., 2005; Hiatt et al., 1990; Hiatt et al., 1994). However, the information available on the effects of isometric training on PAD and its symptoms in

DM is limited. Isometric training studies have been shown to promote an increase in resting vasodilation and post-exercise blood flow (McGowan et al., 2006a; McGowan et al., 2006b; Thompson et al. 2007; Lind & Williams, 1979). As claudication is caused by a reduction in blood flow (Gardner & Montgomery, 2008), and blood flow is calculated as the product of  $(\pi r^2)v$ , ('r' refers to the radius of the blood vessel, 'v' refers to the velocity of the blood), increased resting vasodilation would create a greater pre-exercise blood flow potentially increasing the margin between sufficient and reduced blood flow during exercise, and increased post-exercise blood flow could be an indicator of physiological improvement processes responsible for defending against claudication. Taken together, the potential exists for bilateral lower extremity isometric training to be an effective intervention for claudication caused by PAD in T2D.

At present, investigation into the effect of bilateral lower extremity isometric training on blood flow in individuals with T2D and PAD with debilitating intermittent claudication is limited. Individuals with T2D and intermittent claudication are often unable to participate in any aerobic exercise or participate to a health-beneficial extent due to low-intensity claudication onset. The effect of bilateral lower extremity isometric training on claudication is also limited and warrants further investigation. Bilateral isometric exercise training may act as a bridge to aerobic exercise.



## **1.4 Thesis Objectives**

The purpose of the proposed study is 1) to determine if isometric leg training increases the initial and absolute claudication distances, and 2) to determine if increased blood flow is a potential mechanism responsible for the observed improvements in claudication distances.

## **1.5 Specific Hypotheses**

The primary hypothesis of this study is that in diabetic individuals with PAD bilateral lower extremity isometric training will increase initial and absolute claudication distances (ICD, ACD). A secondary hypothesis is that increased blood flow to the trained limbs is a potential mechanism responsible for the observed improvements in claudication distances.

## **1.6 Clinical Relevance**

The work of this thesis will provide a foundation for and better understanding of the effects of bilateral lower extremity isometric training on PAD in persons with T2D. The results of this research may provide new interventions and protocols for individuals

suffering from PAD and claudication. In addition, the practice of bilateral lower extremity isometric training may also promote better T2D management, as this form of exercise may increase the locomotor ability necessary for the aerobic exercise programs that help control hyperglycemia.

## Reference List

- Alessio, H.M., Hagerman, A.E., Fulkerson, B.K., Ambrose, J., Rice, R.E., & Wiley, R.E. (2000). Generation of reactive oxygen species after exhaustive aerobic and isometric exercise. *Medicine and Sport Science*, 32, 1576-1581.
- Aly, S., Sommerville, K., Adiseshiah, M., Raphael, M., Coleridge, S., & Bishop, C. (1998). Comparison of duplex imaging and arteriography in the evaluation of lower limb arteries. *British Journal of Surgery*, 85, 1099-1102.
- American College of Sports Medicine. (2010). ACSM's guidelines for exercises testing and prescription. Philadelphia, Lippincott Williams & Wilkins.
- American Diabetes Association (2002). Treatment of hypertension in adults with diabetes. *Diabetes Care*, 25, 71-73.
- American Diabetes Association (2003). Peripheral arterial disease in people with diabetes. *Diabetes Care*, 26, 3333-3341
- American Diabetes Association (2004). Peripheral arterial disease in people with diabetes. *Clinical Diabetes*, 22, 181-189.
- American Diabetes Association. (2009). Total prevalence of diabetes & pre-diabetes. Total prevalence of diabetes & pre-diabetes. Retrieved from <http://www.diabetes.org/news-research/research/diabetes-statistics/total-prevalence.html>

American Heart Association. (2008a). PAD risk factors and possible complications.

Retrieved from <http://www.americanheart.org/presenter.jhtml?identifier=3020256>

American Heart Association. (2008b). What is PAD? Retrieved from

<http://www.americanheart.org/presenter.jhtml?identifier=3020249>

American Heart Association. (2009a). PAD treatments and medications. Retrieved from

<http://www.americanheart.org/presenter.jhtml?identifier=3020257>

American Heart Association. (2009b). Peripheral vascular disease. Retrieved from

<http://www.americanheart.org/presenter.jhtml?identifier=4692>

American Heart Association (2011). Hyperglycemia and hypoglycemia. Retrieved from

<http://www.americanheart.org/presenter.jhtml?identifier=4593>

Aserita, M. (1985). *Physiology of stress*. New York, NY, Human Sciences Press.

Atwater, I., Dawson, C., Eddlestone, G., & Rojas, E. (1981). Voltage noise measurements across the pancreatic beta-cell membrane: Calcium channel characteristics.

*Journal of Physiology*, 314, 195-212.

Avery, M., Leon, A., & Kopher, R. (1997). Effect of a partially home-based exercise program for women with gestational diabetes. *Obstetrics & Gynecology*, 89, 10-15.

Avogaro, A., Fadini, G., Gallo, A., Pagnin, E., & de Kreutzenberg, S. (2006). Endothelial dysfunction in type 2 diabetes mellitus. *Nutrition, Metabolism & Cardiovascular Diseases*, 16, 39-45.

- Beckman, J. & Koppenol, W. (1996). Nitric oxide, superoxide and peroxynitrite: The good, the bad and the ugly. *American Journal of Physiology*, 271, 1424-1437.
- Berg, K. (1986). Diabetic's guide to health and fitness. Champaign, IL, Life Enhancement Publications.
- Bernstein, E. & Fronek, A. (1982). Current status of non-invasive tests in the diagnosis of peripheral arterial disease. *Surgical Clinics of North America*, 62, 473-487.
- Boger, R., Bode-Boger, S., Thiele, W., Creutzig, A., Alexander, K., & Frolich, J. (1998). Restoring vascular nitric oxide formation by L-arginine improves the symptoms of intermittent claudication in patients with peripheral arterial occlusive disease. *Journal of the American College of Cardiology*, 32, 1336-1344.
- Borer, K. (2003). Exercise endocrinology. Champaign, IL, Human Kinetics.
- Bruemmer, D. (2006). C-peptide in insulin resistance and vascular complications. *Circulation Research*, 99, 1149-1151.
- Brunzell, J., Robertson, R., Lerner, R., Hazzard, W., Ensink, J., Biermon, E. et al. (1976). Relationship between fasting plasma glucose levels and insulin secretion during intravenous glucose tolerance tests. *Journal of Clinical Endocrinology & Metabolism*, 42, 222-229.
- Canadian Diabetes Association. (2008). Canadian journal of diabetes: Canadian diabetes association 2008 clinical practice guidelines for the prevention and management of diabetes in Canada.

- Canadian Diabetes Association. (2009). Gestational diabetes: Preventing complications in pregnancy. Retrieved from <http://diabetes.ca/about-diabetes/what/gestational/>
- Canadian Diabetes Association. (2011). The prevalence and costs of diabetes. Retrieved from <http://www.diabetes.ca/diabetes-and-you/what/prevalence/>.
- Carbayo, J., Division, J., Escriban, J., Lopez-Abril, J., Lopez de Coca, E., Artigao, L. et al. (2007). Using ankle-brachial index to detect peripheral arterial disease: Prevalence and associated risk factors in a random population sample. *Nutrition, Metabolism & Cardiovascular Diseases*, 17, 41-49.
- Catalano, P., Kirwan, J., Haugel-de Mouzon, S., & King, J. (2003). Gestational diabetes and insulin-resistance: Role in short- and long-term implications for mother and fetus. *Journal of Nutrition*, 133, 1674-1683.
- Centers for Disease Control and Prevention. (2010). 2003 National diabetes fact sheet. Retrieved from <http://www.cdc.gov/diabetes/pubs/general.htm>
- Chiasson, J., Aris-Jilwan, N., Belanger, R., Bertrand, S., Beaugard, H., Ekoe, J. et al. (2003). Diagnosis and treatment of diabetic ketoacidosis and the hyperglycemic hyperosmolar state. *Canadian Medical Association Journal*, 168, 859-866.
- Cihakova, D. (2001). Type 1 diabetes mellitus. Johns Hopkins Medicine: Autoimmune Disease Research Center. Retrieved from <http://autoimmune.pathology.jhmi.edu/diseases.cfm?systemid=3&diseaseid=23>
- Clifton, A. (2000). MR angiography. *British Medical Bulletin*, 56, 367-377.

- Conners, E., Grymkowski, P., Kimber, T., & Reynolds, B. (1992). Gold's gym mass building training and nutrition system. Chicago, IL, Contemporary Publishing Group, Inc.
- Costa, F. & Biaggioni, I. (1998). Role of nitric oxide in adenosine-induced vasodilation in humans. *Hypertension*, 31, 1061-1064.
- Ding, H. & Triggle, C. (2005). Endothelial cell dysfunction and the vascular complications associated with type 2 diabetes: Assessing the health of the endothelium. *Vascular Health and Risk Management*, 1, 55-71.
- Dishman, R., Washburn, R., & Heath, G. (2004). Physical activity epidemiology. Champaign, IL, Human Kinetics.
- Dyck, P. & Thomas, P. (1999). Diabetic neuropathy. Philadelphia, Saunders.
- Ehrman, J., Gordon, P., Visich, P., & Keteyian, S. (2009). *Clinical exercise physiology*. (2nd ed.) Champaign, IL, Human Kinetics.
- Faulx, M., Wright, A., & Hoit, B. (2003). Detection of endothelial dysfunction with brachial artery ultrasound scanning. *American Heart Journal*, 145, 943-951.
- Fery, F. & Balasse, E.O. (1985). Ketone body production and disposal in diabetic ketosis. A comparison with fasting ketosis. *Diabetes*, 4, 326-332.
- Garcia-Patterson, A., Martin, E., Ubeda, J., Maria, M., de Levia, A., & Corcoy, R. (2006). Evaluation of light exercise in the treatment of gestational diabetes. *Diabetes Care*, 24, 2006-2007.

- Gardner, A. & Montgomery, P. (2008). Effects of metabolic syndrome components on exercise performance with patients with intermittent claudication. *Journal of Vascular Surgery*, 47, 1251-1258.
- Gardner, A., Skinner, J., Cantwell, B., & Smith, L. (1999). Progressive versus single-stage treadmill tests for evaluation of claudication. *Medicine and Science in Sports and Exercise*, 23, 402-408.
- Grijalva, J., Hicks, S., Zhao, X., Medikayala, S., Kaminski, P., Wolin, M. et al. (2008). Exercise training enhanced myocardial endothelial nitric oxide synthase (eNOS) function in diabetic Goto-Kakizaki (GK) rats. *Cardiovascular Diabetology*, 7.
- Grundey, S., Benjamin, I., Burke, G., Chait, A., Eckel, R., Howard, B. et al. (1999). Diabetes and cardiovascular disease. *Circulation*, 100, 1146.
- Hambrecht, R., Fiehn, E., Weigl, C., Gielen, S., Hamann, C., Kaiser, R. et al. (1998). Regular physical activity corrects endothelial dysfunction and improves exercise capacity in patients with chronic heart failure. *Circulation*, 98, 2709.
- Hamill, J. & Knutzen, K. (2003). *Biomechanical basis of human movement*. (2nd ed.) Baltimore: Lippinott, Williams & Wilkins.
- Hardie, G. (2002). Models for regulation by AMPK/SNF1 of glucose uptake in muscle and gene expression in yeast. *Nature Reviews Molecular Cell Biology*, 8, 774-785.



- Hayden, M. & Tyagi, S. (2002). Is type 2 diabetes mellitus a vascular disease (atheroscleropathy) with hyperglycemia a late manifestation? The role of NOS, NO and redox stress. *Cardiovascular Diabetology*, 2.
- Herlihy, J.T., Bockman, E.L., Berne, R.M., & Rubio, R. (1976). Adenosine relaxation of isolated vascular smooth muscle. *American Journal of Physiology*, 230, 1239-1243.
- Heyward, V. (2006). Advanced fitness assessment and exercise prescription. 5th. Champaign, IL, Human Kinetics.
- Hiatt, W., Nawaz, D., Regensteiner, J., & Hossack, K. (1998). The evaluation of exercise performance in patients with peripheral vascular disease. *Journal of Cardiopulmonary Rehabilitation and Prevention*, 12, 525-532.
- Hiatt, W., Regensteiner, J., Hargarten, M., Wolfel, E., & Brass, E. (1990). Benefits of exercise conditioning for patients with peripheral arterial disease. *Circulation*, 81, 602-609.
- Hiatt, W., Wolfel, E., Meier, R., & Regensteiner, J. (1994). Superiority of treadmill walking exercise versus strength for patients with peripheral arterial disease. Implications for the mechanism of the training response. *Circulation*, 90, 1866-1874.
- Hird, J. & Symons, R. (1962). The mechanism of ketone-body formation from butyrate in rat liver. *Biochemical Journal*, 84, 212-216.

- Holten, M., Zacho, M., Gaster, M., Juel, C., Wojtaszewski, J., & Dela, F. (2004). Strength training increases insulin-mediated glucose uptake, GLUT4 content, and insulin signaling in skeletal muscle in patients with type 2 diabetes. *Diabetes*, *53*, 294-305.
- Ikonen, E. (2008). Cellular cholesterol trafficking and compartmentalization. *Nature Reviews Molecular Cell Biology*, *9*, 125-138.
- Imparato, A., Kim, G., Davidson, T., & Crowley, J. (1975). Intermittent claudication: Its natural course. *The American Journal of Surgery*, *78*, 795-799.
- Inagaki, N., Yasuda, K., Inoue, G., Okamoto, Y., Yano, H., Someya, Y. et al. (1992). Glucose as a regulator in glucose transport activity and glucose-transporter mRNA in hamster beta-cell lines. *Diabetes*, *41*, 592-597.
- Jewell, J.J., Oh, E., & Thurmond, D.C. (2010). Exocytosis mechanisms underlying insulin release and glucose uptake: conserved roles for Munc18c and syntaxin 4. *American Journal of Physiology: Regulatory, Integrative and Comparative Physiology*, *298*, 517-531.
- Jimenez, C., Santiago, M., Sitler, M., Boden, G., & Homko, C. (2009). Insulin-sensitivity response to a single bout of resistive exercise in type 1 diabetes mellitus. *Journal of Sports Rehabilitation*, *18*, 564-571.
- Kalant, N. (1978). Diabetic glomerulosclerosis: Current status. *Canadian Medical Association Journal*, *119*, 146-153.

- Kannel, W. & McGee, D. (1979). Diabetes and cardiovascular disease. *The Journal of the American Medical Association*, 241, 2035-2038.
- Kennedy, J., Hirshman, H., Gervin, E., Ocel, J., Forse, R., Hoeing, S. et al. (1999). Acute exercise induces GLUT4 translocation in skeletal muscle of normal human subjects and subjects with type 2 diabetes. *Diabetes*, 48, 1192-1197.
- Klip, A. & Paquet, M. (1999). Glucose transport and glucose transporters in muscles and their metabolic regulation. *Diabetes Care*, 13, 288-293.
- Kloppel, G., Lhor, M., Habich, K., Oberholzer, M., & Heitz, P.U. (1985). Islet pathology and the *pathogenesis of type 1 and type 2 diabetes mellitus revisited*. *Survey and Synthesis of Pathology Research*, 4, 110-125.
- Koya, D. & King, G. (1998). Protein kinase C activation and the development of diabetic complications. *Diabetes*, 47, 859-866.
- Kruth-Kraczek, E., Hirshman, M., Goodyear, L., & Windder, W. (1999). 5'AMP-activated protein kinase activation causes GLUT4 translocation in skeletal muscle. *Diabetes*, 48, 1667-1671.
- Kusari, A., Byon, J., Bandyopadhyay, D., Kenner, K., & Kusari, J. (1997). Insulin-induced mitogen-activated protein (MAP) kinase phosphatase-1 (MKP-1) attenuates insulin-stimulated MAP kinase activity: A mechanism for feedback inhibition of insulin signaling. *Molecular Endocrinology*, 11, 1532-1543.

- Landt, K., Campaigne, B., James, F., & Sperling, M. (1985). Effects of exercise training on insulin sensitivity in adolescents with type 1 diabetes. *Diabetes Care*, 8, 461-465.
- Lafontan, M., Moro, C., Berlan, M., Crampes, F., Sengenès, C., & Galitzky, J. (2008). Control of lipolysis by natriuretic peptides and cyclic GMP. *Trends in Endocrinology & Metabolism*, 19, 130-137.
- Large, V. & Arner, P. (1998). Regulation of lipolysis in humans. Pathophysiological modulation in obesity, diabetes, and hyperlipidaemia. *Diabetes & Metabolism*, 24, 409-418.
- Li, H. & Fostermann, U. (2000). Nitric oxide in the pathogenesis of vascular disease. *Journal of Pathology*, 190, 244-254.
- Lind, A. & Williams, C. (1979). The control of blood flow through human forearm muscles following brief isometric contractions. *Journal of Applied Physiology*, 288, 529-549.
- Lopes-Carodoso, M., Mulder, I., Hermans, P., van den Burgh, S., Klazinga, W., de Vries-Akkerman, E. et al. (1975). Aspects of ketogenesis: Control and mechanism of ketone-body formation in isolated rat-liver mitochondria. *Molecular and Cellular Biochemistry*, 9, 155-173.
- Malecki, M. (2005). Genetics of type 2 diabetes mellitus. *Diabetes Research and Clinical Practice*, 68, 10-21.

- McDermott, M., Ades, P., Guralnik, J., Dyer, A., Ferrucci, L., Liu, K. et al. (2009). Treadmill exercise and resistance training in patients with peripheral arterial disease with and without intermittent claudication: A randomized controlled trial. *Journal of the American Medical Association*, 301, 165-174.
- McGowan, C., Levy, A., Millar, P., Guzman, J., Morillo, C., McCartney, N. et al. (2006a). Acute vascular responses to isometric handgrip exercise and effects of training in persons medicated for hypertension. *American Journal of Physiology*, 291, 1797-1802.
- McGowan, C., Visocchi, A., Faulkner, M., Verdyun, R., Rakobowchuk, M., Levy, A. et al. (2006b). Isometric hand grip training improves local flow-mediated dilation in medicated hypertensives. *European Journal of Applied Physiology*, 98, 355-362.
- Morris, T. & Jardine, A. (2000). The vascular endothelium in chronic renal failure. *Journal of Nephrology*, 13, 96-105.
- Nash, D. (2002). Insulin-resistance, ADMA levels and cardiovascular disease. *Journal of the American Medical Association*, 287, 1451-1452.
- National Diabetes Information Clearinghouse. (2008). Hypoglycemia. Retrieved from <http://diabetes.niddk.nih.gov/dm/pubs/hypoglycemia/>
- National Institute of Diabetes and Digestive and Kidney Diseases. (2008). National kidney and urologic diseases information clearing house. Retrieved from <http://kidney.niddk.nih.gov/Kudiseases/pubs/kdd/>

- National Institute of Diabetes and Digestive and Kidney Diseases. (2009). Diabetic neuropathies: The nerve damage of diabetes. Retrieved from <http://diabetes.niddk.nih.gov/DM/pubs/neuropathies/>
- National Institute of Neurological Disorders and Stroke. (2008). NINDS Diabetic neuropathy information page. Retrieved from <http://www.ninds.nih.gov/disorders/diabetic/diabetic.htm>
- Oguri, M., Adachi, H., Ohno, T., Oshima, S., & Kurabayashi, M. (2009). Effect of a single bout of moderate exercise on glucose uptake in type 2 diabetes mellitus. *American Journal of Cardiology*, 53, 8-14.
- Permutt, M., Wasson, J., & Cox, N. (2005). Genetic epidemiology of diabetes. *Journal of Clinical Investigation*, 115, 1431-1439.
- Peters, P.G., Alessio, H.M., Hagerman, A.E., Ashton, T., Nagy, S., & Wiley, R.L. (2006). Short-term isometric exercise reduces systolic blood pressure in hypertensive adults: Possible role of reactive oxygen species. *International Journal of Cardiology*, 110, 199-205.
- Pierratos, A. (1999). Nocturnal hemodialysis: dialysis for the new millenium. *Canadian Medical Association Journal*, 161, 1137.
- Powers, S. & Howley, E. (2009). Exercise physiology: Theory and application to fitness and performance. 7. New York, NY, McGraw-Hill.
- Rader, D. & Daugherty, A. (2008). Translating molecular discoveries into new therapies for atherosclerosis. *Nature*, 451, 904-913.

- Radiological Society of North America. (2010). Catheter angiography. Retrieved from <http://www.radiologyinfo.org/en/info.cfm?pg=angiocath>
- Ray, C. & Carrasco, D. (2000). Isometric handgrip training reduces arterial pressure at rest without changes in sympathetic nerve activity. *American Journal of Physiology*, 279, 245-249.
- Robinson, K. & Buse, M. (2008). Mechanisms of high-glucose/insulin-mediated desensitization of acute insulin-stimulated glucose transport of Akt activation. *American Journal of Physiology, Endocrinology & Metabolism*, 294, 870-881.
- Rose, N. & Afanasyeva, M. (2003). Autoimmunity: Busting the atherosclerotic plaque. *Nature Medicine*, 9, 641-642.
- Scottish Intercollegiate Guidelines Network (2006). *Diagnosis and management of peripheral arterial disease: A national clinical guideline*. Edinburgh: NHSScotland.
- Sensier, Y., Hartshorne, T., Thrush, A., Nydahl, S., Bolia, A., & London, N. (1996). A prospective comparison of lower limb colour-coded Duplex scanning with arteriography. *European Journal of Vascular and Endovascular Surgery*, 11, 170-175.
- Sessa, W., Pritchard, K., Seyedi, N., Wang, J., & Hintze, T. (1994). Chronic exercise in dogs increases coronary vascular nitric oxide synthase production and endothelial cell nitric oxide synthase gene expression. *Circulation Research*, 74, 349-353.

- Taylor, A., McCartney, N., Kamath, M., & Wiley, R. (2003). Isometric training lowers resting blood pressure and modulates autonomic control. *Medicine and Science in Sports and Exercise*, 35, 251-256.
- The Kidney Foundation of Canada. (2009a). Hemodialysis. Retrieved from <http://www.kidney.ca/Page.aspx?pid=338>
- The Kidney Foundation of Canada. (2009b). Transplantation. Retrieved from <http://www.kidney.ca/Page.aspx?pid=340>
- The Kidney Foundation of Canada. (2009c). What is chronic kidney disease (CKD)? Retrieved from <http://www.kidney.ca/Page.aspx?pid=320>
- Thompson, B., Fadia, T., Pincivero, D., & Scheuermann, B. (2007). Forearm blood flow responses to fatiguing isometric contractions in women and men. *American Journal of Physiology*, 293, 805-812.
- Treat-Jacobson, D., Bronas, U., & Leon, A. (2009). Efficacy of arm-ergometry versus treadmill exercise training to improve walking distance in patients with claudication. *Vascular Medicine*, 14, 203-213.
- Turrens, J. (2003). Mitochondrial formation of reactive oxygen species. *The Journal of Physiology*, 552, 335-344.
- Ueda, H., Howson, J., Esposito, L., Heward, J., Snook, H., & Chamberlain, G. (2003). Association of the T-cell regulatory gene CTLA4 with susceptibility to autoimmune disease. *Nature*, 423, 506-511.



- University of Virginia Health System. (2007). Diabetes: Type 2 diabetes. Retrieved from [http://www.healthsystem.virginia.edu/uvahealth/adult\\_diabetes/type2.cfm](http://www.healthsystem.virginia.edu/uvahealth/adult_diabetes/type2.cfm)
- Vinik, A., Strotmeyer, E., Nakave, A., & Patel, C. (2008). Diabetic neuropathy in older adults. *Clinics in Geriatric Medicine*, 24, 407-439.
- Wang, E., Helgerud, J., Loe, H., Indseth, K., Kaehler, N., & Hoff, J. (2009). Maximal strength training improves walking performance in peripheral arterial disease patients. *Scandinavian Journal of Medicine and Science in Sports*, 19, 623-631.
- Weir, G. & Bonner-Weir, S. (2004). Five stages of evolving beta-cell dysfunction during progression to diabetes. *Diabetes*, 53, 16-21.
- Weyer, C., Bogardus, C., Mott, D.M., & Pratley, R.E. (1999) The natural history of insulin secretory dysfunction and insulin resistance in the pathogenesis of type 2 diabetes mellitus. *Journal of Clinical Investigation*, 104, 787-794.
- Wiles, J., Coleman, D., & Swaine, I. (2009). The effects of performing isometric training at two exercise intensities in healthy young males. *European Journal of Applied Physiology*.
- Winnick, J., Sherman, W., Habash, L., Stout, M., Failla, M., Belury, M. et al. (2008). Short-term aerobic exercise in obese humans with type 2 diabetes mellitus improves whole-body insulin sensitivity through gains in peripheral, not hepatic insulin sensitivity. *Journal of Clinical Endocrinology & Metabolism*, 93, 771-778.
- World Health Organization. (2008). Diabetes fact sheet. Retrieved from <http://www.who.int/mediacentre/factsheets/fs312/en/>

- World Health Organization. (2009a). Cardiovascular disease: Prevention and control. Retrieved from <http://www.who.int/dietphysicalactivity/publications/facts/cvd/en/>
- World Health Organization. (2009b). Cardiovascular diseases (CVDs). Retrieved from <http://www.who.int/mediacentre/factsheets/fs317/en/index.html>
- Yoshimura, M., Oshima, T., & Ogasawara, N. (2007). Involvement of the YneS/YgiH and PlsX proteins in phospholipid biosynthesis in both bacillus subtilis and escherichi coli. *BMC Microbiology*, 7.
- Zimmet, P., Alberti, K., & Shaw, J. (2001). Global and societal implications of the diabetes epidemic. *Nature*, 414, 782-787.
- Zwierska, I., Walker, R., Choksy, S., Male, J., Pockley, A., & Saxton, J. (2005). Upper vs lower-limb aerobic exercise rehabilitation in patients with symptomatic peripheral arterial disease: A randomized controlled trial. *Journal of Vascular Surgery*, 42, 1122-1130.

**CHAPTER 2: Lower Extremity Isometric Training and its Effect on  
Type 2 Diabetic Claudication**

**MANUSCRIPT**

## 2.1 Introduction

Type 2 diabetes mellitus (T2D) affects over 180 million people worldwide (World Health Organization, 2008), of which 1.7 million are Canadian (Statistics Canada, 2010). These figures are only the reported cases and show a trend that displays a steadily increasing affected population (Statistics Canada, 2010). T2D is a disease characterized by elevated blood glucose (hyperglycemia) due to inadequate insulin action and decreased insulin sensitivity (Weir & Bonner-Weir, 2004) and is associated with numerous co-morbidities, a prominent one of which is peripheral arterial disease (PAD). PAD is a progressive disorder defined by structural changes in blood vessels and is associated with poor endothelial function (e.g., reduced nitric oxide (NO)-mediated or endothelial-dependent arterial vasodilation) and dyslipidemia (abnormal lipid profile) causing intermittent claudication (leg cramping) as a result of reduced blood flow during aerobic exercise (American Heart Association, 2008). Up to an estimated 54% of the T2D population have PAD (Faglia et al., 1998; Hirsch et al., 2001).

Aerobic exercise training is a cornerstone therapy in the management of T2D (American College of Sports Medicine, 2010), and is associated with increased insulin sensitivity (Oguri, Adachi, Ohno, Oshima, & Kurabayahi, 2009; Winnick et al., 2008) and improved glucose regulation (Kennedy et al., 1999). PAD can also be successfully managed with aerobic exercise training (Treat-Jacobson, Bronas, & Leon, 2009), and is responsible for increased locomotive ability and reduced leg cramping in the PAD population (American Diabetes Association, 2003). Treat-Jacobson and colleagues (2009) found that 12 weeks of aerobic exercise training using arm ergometry, treadmill walking or both, increased maximal walking distance (absolute claudication distance;

ACD) by approximately 53%, 69% and 68%, respectively in a population of T2D with PAD population. Aerobic walking exercise programs (3 hours of walking per week, at a self-selected pace) lasting 12 have shown to increase maximal walking time by approximately 74% in a population of PAD patients with and without T2D (Hiatt, Wolfel, Meier, & Regensteiner, 1994).

Although aerobic exercise is the universally accepted exercise-form of treatment and management in diabetic individuals with PAD, as these patients are often limited by leg cramping, this form of exercise can be excessively challenging and, in some cases, intolerable (American College of Sports Medicine, 2010). This often discourages individuals from seeking out or adhering to aerobic exercise training programs.

A form of exercise that promotes prolonged increases in post-exercise blood flow is isometric exercise, which is relatively under-investigated, especially in clinical populations. For example, a single bout of isometric handgrip exercise increases blood flow to the working tissues post-exercise in healthy and clinical (e.g., hypertensive) populations using bilateral or unilateral, single and multiple contraction protocols at varying intensities (Lind & Williams, 1979; Thompson et al., 2007; McGowan et al., 2006a), yet it is also associated with an acute attenuation in endothelium-dependent vasodilation in the latter populations (McGowan et al., 2006a). Chronic upper extremity isometric exercise training is associated with an increase in resting vasodilatory capacity (McGowan et al., 2006a), however, with respect to acute bout hemodynamics, neither the magnitude of the increase in post-exercise blood flow is augmented, nor is the transient reduction in endothelium-dependent vasodilation is ameliorated with training. The likely cause of reduced NO-mediated or endothelial-dependent arterial vasodilation is

peroxynitrite formation from a reaction between NO and reactive oxygen species (ROS) (Li & Fostermann, 2000), which are created during ischemic conditions (Alessio et al., 2000) such as isometric exercise. This phenomenon of increased blood flow/decreased endothelial function, irrespective of training status, could be due to an accumulation of metabolites, such as adenosine (Costa & Biaggioni, 1998), that cause the dilation of blood vessels in order to decrease their local concentration (Herlihy, Bockman, Berne, & Rubio, 1976) thus not requiring endothelial-dependent vasodilation.

To date, there are few published bilateral lower extremity isometric training studies and none on the effects on blood flow or endothelial function in T2D claudication. One study examined resting arterial blood pressure (BP) in healthy individuals performing 4, 2 minute contractions at 30% maximum voluntary contraction 3 days per week for 8 weeks (Wiles, Coleman, & Swaine, 2009). It is possible that chronic exposure to a larger isometric stimulus (due to larger muscle mass), such as a bilateral lower extremity isometric training protocol, may elicit greater post-training improvements in resting endothelial function while concomitantly ameliorating or improving post-exercise endothelial dysfunction, as higher intensity upper extremity isometric training can significantly reduce the formation of exercise-induced ROS (Peters et al., 2006). To add, acute isometric exercise bouts have been proven to significantly increase shear stress (a stimulus responsible for the metabolic cascade necessary for vasodilation and subsequent blood flow) (McGowan et al., 2006b), therefore, repeated bouts of bilateral isometric exercise (training) could produce a larger and potentially longer lasting metabolic effect of shear stress, allowing for delayed onset of blood flow reduction during aerobic exercise in the T2D/PAD population. It is also possible that the

larger blood vessels of the lower extremities may require more time for metabolite accumulation preventing metabolite-aided vasodilation thus increasing the reliance on endothelium-dependent vasodilation and fostering improvements in endothelial dysfunction.

The increase in vasodilation and blood flow would allow individuals to exercise aerobically for longer and reap the benefits for their T2D and PAD treatment. Increased resting vasodilation may create a greater initial or pre-exercise blood flow potentially increasing the margin between sufficient and reduced blood flow during exercise. As reduced blood flow causes claudication, this would increase the time to claudication. Increased post-exercise blood flow could be an indicator of improvement in physiological processes responsible for defending against claudication.

At present, investigation into the effect of bilateral lower extremity isometric exercise training on vascular function, including blood flow, in individuals with T2D and PAD with debilitating intermittent claudication is limited. As previously mentioned, individuals with T2D and intermittent claudication are often unable to participate in aerobic exercise due to low-intensity claudication onset. In this situation, isometric exercise training may act as a bridge to aerobic exercise.

## **2.2 Purposes and Hypotheses**

The purpose of the current study was to test the primary hypothesis that in diabetic individuals with PAD, 8 weeks of bilateral lower extremity isometric training will increase initial and absolute claudication distances (ICD, ACD). A secondary purpose was to test the hypothesis that increased blood flow to the trained limbs is a potential mechanism responsible for the observed improvements in claudication distances.

## **2.3 Methods**

### **2.3.1 Participants**

This study was cleared by the University of Windsor Research Ethics Board (REB#10-101) (see Appendix A), as well as the Windsor Regional Hospital Research Ethics Board (see Appendix B). Individuals with concurrent T2D and PAD (diagnosed by their primary care physician) aged 18 years and older, were recruited over an 11 month period to participate in this study. Patients were excluded if they had a lower extremity amputation, walked with an assisting device (walker, cane, etc.), had heart failure and/or a cardiovascular event (cardiac arrest, stroke, transient ischemic attack) or hospitalization in the 12 weeks prior to the study (American College of Cardiology/American Heart Association, 2004). Individuals were recruited from the University of Windsor's general population, local physician offices, diabetes community



programs, cardiovascular and chronic disease management programs, and the community at large. Participants were recruited by means of a poster campaign (see Appendix C) across the previously stated locations and via personal interaction.

Participant characteristics are presented in Tables 2.1-2.4. Forty individuals were recruited to participate in the study, but rejected their participation due to time constraints. Six individuals attended the initial visit, however, 1 individual was excluded from the study due to a vascular surgery procedure and another individual dropped out before the testing day. Ultimately, four individuals with T2D and PAD participated in this study. All participants were Caucasian males, age  $65.3 \pm 4.6$  years (Mean  $\pm$  SD) and were regular exercisers ( $1.8 \pm 0.9$  hours per day,  $4.8 \pm 2.1$  days per week). At the time of the study, each participant was on standard pharmacotherapy for T2D and PAD, however, no one was being treated for claudication pain. Only two participants completed the 8-week intervention; due to circumstances beyond control of the investigators, the remaining 2 participants completed a 7- and 6-week intervention, respectively.

### **2.3.2 Study Design**

This study was designed as a randomized, controlled trial; however, due to poor recruitment, it was collapsed into a within-study design, using an intent-to-treat approach.

After inquiring about the study, participants were required to meet with the study investigators at the Physical Activity & Cardiovascular Research (PACR) Lab (Room #240, Human Kinetics Building, University of Windsor, ON, Canada) for an

informational meeting. During the meeting, the participants signed a letter of information (see Appendix D), signed an informed letter of consent (see Appendix E), completed a medical questionnaire (see Appendix F) and were given the physical activity readiness medical examination (PARmed-X) (see Appendix G) to be signed by their primary care physician. Following the establishment of eligibility via the medical questionnaire and PARmed-X, participants returned to the PACR Lab for familiarization of all testing and training procedures and completed a personal history questionnaire (see Appendix H) and signed a medical history release form (see Appendix I).

### ***Testing Protocol***

Testing took place over 1 day (approximately 1 hour), prior to (week 0) and following (week 7 or 8 or 9) the intervention. To minimize the influence of external factors on the tested measures, participants were asked to refrain from the consumption of alcohol and caffeine for 12 hours prior (McGowan et al., 2006a) and smoking for 30 minutes prior (Primatesta et al., 2001). On the testing days, participants were required to wear a short-sleeved t-shirt and shorts to ensure accuracy of measurements.

All testing took place in the PACR Lab. First, the participants rested in the supine position for 10 minutes (Weatherley et al., 2006), after which arterial BP (Dinamap ProCare 100, Critikon, Tampa, FL, USA; see Appendix J) was acquired using automated arterial oscillometry in the following order: right brachial BP, left brachial BP, right posterior tibial BP, left posterior tibial BP, right dorsalis pedis BP and left dorsalis pedis BP. BP was taken once more in the same order to give two series of BP measurements.

These measurements were used in the analysis of individual leg ankle-brachial index (ABI; described below), a measure of PAD severity and disease progression.

Next, participants underwent a pre-walking popliteal artery duplex scan using B-mode and Doppler-mode ultrasound (Vivid *i*, GE Health, Pittsburgh, Pennsylvania, USA; see Appendix K) (frequency=8.0/4.4 MHz; depth=4.0/5.0 cm; angle of isonation=60°) with electrocardiogram (ECG) gating. Participants were required to lie in the prone position with the backs of their knees accessible to the investigator. The diameter of each popliteal artery and the concomitant blood velocities were collected continuously for 1 minute (Parker et al., 2006).

Once the necessary popliteal images were acquired, participants performed a graded-exercise treadmill test as per the Gardner protocol (see Appendix L). In brief, participants stated when they first felt pain/cramping in their legs (initial claudication distance; ICD) and when the pain/cramping became too intense to withstand the test any further (absolute claudication distance; ACD). Immediately after the completion of the treadmill test, all participants underwent a post-walking popliteal artery duplex scan following the same protocol as previously described.

### ***Training Protocol***

Participants trained 3 times per week, for a total of 6, 7 or 8 weeks. Each training session took place in the PACR Lab under the direct supervision of an exercise trainer. Participants were first asked if there had been any change in medication, nutrition or physical activity routine (McGowan, et al. 2007) to ensure that these variables remained unchanged throughout the study. Next, participants had their blood glucose levels

analyzed using a commercially available blood glucose monitoring system (Abbott Laboratories Freestyle Freedom Lite; see Appendix M) where blood was applied to the system's testing strip after being lanced with a spring-loaded lancet (Accucheck SoftClix; see Appendix N). Individuals with a blood glucose reading of less than 4 mM were to be given a carbohydrate snack to prevent possible adverse effects of hypoglycemia (Canadian Diabetes Association, 2004).

After blood glucose analysis, resting BP and ABI (following the same protocol as the testing days; data not used for analysis) were acquired after 10 minutes of supine rest. After the establishment of a safe BP, brachial systolic BP of  $\geq 200$  mmHg or diastolic BP of  $\geq 110$  mmHg (American College of Sports Medicine, 2010), participants performed bilateral lower extremity isometric exercise using the Lower Leg Isometric Training Apparatus (LoLITA; see Appendix O). Specifically, 4 sets of bi-legged, 2-minute isometric lower extremity contractions at 30% maximal voluntary contraction (MVC; determined at the onset of each training session via the Sustain Optimal Load Exercise Software (SOLES) program contained within LoLITA) were performed, each separated by 2-minute rest intervals (Wiles et al., 2009). Throughout the isometric exercise, BP was monitored every 2 minutes, as a safety precaution. Immediately post-exercise, blood glucose (as a precaution for hypoglycemia; same action plan as for the pre-training blood glucose analysis), BP and ABI were assessed.

## *Data Analysis*

### *Claudication Distances*

As previously mentioned, ICD and ACD were determined using the Gardner Protocol (see Appendix L). This standardized test is used clinically across all age groups and disease states and has a within-subject variation of 15-25% for ICD and 12-13% for ACD (Hiatt, Nawaz, Regensteiner, & Hossack, 1998). Prior to the commencement of the graded-exercise treadmill test, participants were asked to only speak to the investigator at the time of the initial onset of leg pain/cramping (ICD) and when they felt they could no longer withstand the test (ACD). To control for the influence of motivation on time to claudication, the investigator only spoke to notify participants of the incline increase during the test and to acknowledge the claudication distances. Furthermore, participants were blinded to their pre-intervention results following training.

### *Pre-Exercise and Post-Exercise Blood Flow*

Blood flow was calculated separately for each artery using the product of  $(\pi r^2)v$  where 'r' refers to the radius of the blood vessel and 'v' refers to the velocity of the blood (McGowan et al., 2006b). The radius of each artery was determined from the artery's diameter. Specifically, three diameters (leading-edge to leading-edge) of the artery were obtained at each R peak of the QRS-complex of the electrocardiogram for the entire minute (Parker, Ridout & Proctor, 2006). The three diameters of each R peak were averaged, and then that average was averaged with the other R peak averages (Parker, Ridout & Proctor, 2006), then divided by two to give the artery's radius. Average mean blood velocity was determined using the average of all the timed-average means of beat-

to-beat mean blood velocity of that artery (Vivid *i*, GE Health, Pittsburgh, Pennsylvania, USA). Diameter and velocity raw data is presented in Tables 3.1 and 3.2.

To ensure measurement accuracy the same investigator performed all testing and analysis procedures. To further enhance accuracy, the investigator used anatomic landmarks and compared each participant's subsequent arterial duplex images to his initial arterial duplex image.

### ***Resting ABI***

The resting ankle-brachial index (ABI) was determined with a calculation using the various BP measurements obtained during the testing days. The highest brachial BPs from each series and the highest ankle BP (dorsalis pedis or posterior tibial) of each leg from the same series were used to calculate the ankle-brachial index (quotient of the ankle arterial systolic BP and brachial arterial systolic BP) (Benchimol et al., 2004; Beckman, Higgins, & Gerhard-Herman, 2006). The average ABI of the two series for each leg was used. Resting ABI data is presented in Tables 3.3.

### ***Blood Glucose***

Blood glucose measurements were obtained and analyzed using a commercially available blood glucose monitoring system (Abbott Laboratories Freestyle Freedom Lite; see Appendix M) where blood was applied to a the system's testing strip after being lanced from the participants' thumbs, index or middle fingers with a spring-loaded lancet.

### ***Statistical Analysis***

Statistical significance was set at  $P \leq 0.05$ . A Sign Test, a non-parametric test which is designed to test results against predicted hypotheses, was performed on claudication distance and blood flow data. A repeated measures analysis of variance, a parametric test which measures the effect of an intervention on the same characteristic under different conditions, was performed to assess the effects of training on the change in blood glucose concentrations pre- and post-exercise. All tests were performed using Predictive Analytics Software version 18 (PASW 18).

## **2.4 Results**

### ***ICD/ACD***

Following bilateral lower extremity isometric training, ICD and ACD improved by an average of  $116.3 \pm 26.3\%$  (pre:  $165.9 \pm 107.9$  m to post:  $338.0 \pm 171.9$  m) and  $47.5 \pm 34.1\%$  (pre:  $390.3 \pm 163.8$  m to post:  $559.3 \pm 208.8$  m), respectively. First, the claudication distance data was statistically analyzed as two separate data sets in two separate Sign Tests: 1) ICD ( $Z=1.5$ ;  $p=.125$ ) and, 2) ACD ( $Z=1.5$ ;  $p=.125$ ). Both data sets displayed no statistical significance. As the Sign Test is a non-parametric test which does not require data normality or homogeneity, and as ICD and ACD are related because they both measure claudication distance, the two data sets were pooled into one to increase the power of the data. Statistically significant increases were observed in the pooled

claudication distance data ( $Z=2.475$ ;  $p=.008$ ). Guidelines for clinically significant improvements in claudication distance(s) do not exist, therefore it is unclear if the improvements classify as clinically significant as well as statistically. See Table 4.1.

### ***Blood Flow***

The effect of bilateral lower extremity isometric training on blood flow was analyzed first by assessing each of the four separate data sets in four separate Sign Tests: 1) Pre-exercise right leg blood flow ( $Z=0$ ;  $p=1.0$ ), 2) Pre-exercise left leg blood flow ( $Z=.5$ ;  $p=.625$ ), 3) Post-exercise right leg blood flow ( $Z=.5$ ;  $p=.625$ ), and 4) Post-exercise left leg blood flow ( $Z=1.5$ ;  $p=.125$ ). As no statistical significance was detected with any analyses, the four data sets were pooled into one. However, no statistically significant changes in blood flow were observed ( $Z=.516$ ,  $p=.607$ ). See Tables 4.2 and 4.3.

### ***ABI***

Following training, there were neither statistically significant (all  $p>0.05$ ) nor clinically relevant changes in ABI (see Table 3.3). With respect to the latter, clinically, a decrease in ABI of 0.15 indicates PAD progression (McLafferty, Moneta, Taylor, & Porter, 1997; Criqui, Ninomiya, Wingard, Ji & Fronek, 2008), while an increase in ABI of 0.15 is indicative of disease improvement (as seen post-surgical intervention) (Eberhardt, 2003). Collectively, these data suggest there were no changes in ABI and subsequently no disease progression.

### ***Blood Glucose***

The change in blood glucose concentrations from pre- to post-exercise session remained unchanged with training,  $F(3, 54)= 1.39$ ,  $p=0.255$ . See Table 3.4.



## 2.5 Discussion

T2D is a highly prevalent chronic disease worldwide, and PAD is a common comorbidity associated with the disease. PAD causes severe claudication pain in the lower legs during activities as simple as walking, due to insufficient blood flow, and thus negatively influences exercise capacity. This is concerning, as aerobic exercise is a key form of treatment and management in T2D.

Isometric exercise is a novel form of exercise that is non-claudication promoting, improves local resting vasodilatory function in clinical populations and increases local post-exercise blood flow in healthy and clinical populations. Considering this evidence, isometric exercise has the potential to be a viable intervention to increase ICD and ACD by increasing blood flow to the trained tissues, subsequent to or independent of increased local vasodilatory function. Furthermore, isometric exercise performed using a large muscle mass may encourage greater improvements in those variables.

In support of the primary hypothesis, bilateral lower extremity isometric exercise training performed at 30% MVC for 4, 2-minute contractions increased ICD and ACD. The mechanism(s) responsible for this increase remain unclear, and as popliteal artery blood flow remained unchanged in the current study, it is an unlikely mechanism. One possible mechanism may be an increase in collateral blood vessel circuits (Murrant, 2008). Animal studies have shown that regular physical activity can increase the conductance of these collateral vessels (Murrant, 2008), providing blood flow to areas affected by PAD, and delaying claudication.

Another possible and more probable mechanism for increased claudication distance is ischemic adaptation. Individuals with PAD have low-functioning and depleted amounts of vascular smooth muscle cells (VSMCs) (Bennett, 2006; Bennett, Macdonald, Chan, Boyle, & Weissberg, 1998; Ross, Wight, Strandess, & Thiele, 1984), leading to attenuated NO metabolism and impaired vasodilation. Sustained isometric contractions can temporarily attenuate blood flow due to vascular constriction or collapse, and exercises which cause ischemic conditions during their performance increase NO availability (Kimura et al., 2007). Therefore, the more readily available NO could travel to the mitochondrial cells of skeletal muscles where it causes attenuation in oxygen consumption (Cooper & Brown, 2008) promoting greater oxygen availability for muscle contraction-relaxation which delays muscle cramping.

As previously mentioned, popliteal artery blood flow remained unchanged with training. It is possible that the participants had very severe endothelial damage that could not be improved in the short-term training period. The progression of PAD (measured by changes in ABI) correlates with increasing endothelial dysfunction and decreased vasodilatory ability (Brevetti et al., 2003), however, individuals with PAD who have T2D are very prone to arterial calcification (Chen & Moe, 2003) causing arteries to become permanently stiff and rigid. Stiffening of the arteries causes artefactually elevated ABIs (Bernstein & Fronck, 1982) masking the true severity of PAD and the extent of endothelial dysfunction. Also, calcification alone causes arteries to have dysfunctional endothelium and poor distensibility (Giachelli, 2004) and therefore, low vasodilatory ability. However, this study did not measure endothelial function directly, therefore, this theory cannot be fully supported nor ruled out. Although medication and diet was closely

monitored throughout the study, specific medication and nutritional data were not acquired, and thus one or more pharmacological and/or nutritional factor(s) may have influenced the ability of the endothelium to change.

Another reason for the lack of blood flow improvement could be the location of and/or the time course of the blood flow measurement. First, this study assessed blood flow using only the popliteal artery, which is a conduit and not a collateral vessel. As previously mentioned, collateral blood vessel circuits increase their conductance with exercise and may be responsible for increased blood flow to areas below atherosclerotic disease and arterial occlusions (Murrant, 2008). Second, blood flow during exercise was not examined, therefore there is no data to determine or interpret hemodynamics during exercise and at the time of claudication.

## **2.6 Limitations**

This study was limited due to the sample size which affected the power of the study. The study was originally designed as a randomized, controlled trial, but had to be collapsed to a within-subject design. Without a control group it was difficult to assess the magnitude of the isometric training intervention. Difficulty with participant recruitment can be attributed to the training protocol as many of the prospects declined their participation because of the amount of on-site time required (approximately 1 hour, 3

times per week for 8 weeks). Some potential participants were living in elderly care facilities with no mode of regular transportation to the facility.

This study employed an intent-to-treat approach. The primary goal of the study was to increase both ICD and ACD in individuals with T2D and PAD, and although performed with a small sample size and differing intervention lengths, the study did show positive and statistically significant results with respect to claudication distances. These results can be confidently defended because the tool used to assess claudication distance, the Gardner Protocol, is widely used in both clinical and research domains, and has low within-subject variability, even though participant self-motivation may skew data. This study's results were also obtained from male participants with similar between-subject characteristics such as age, ethnicity, physical activity level and prescribed medication. To further add to the strength of this study's findings, the participants had differing between-subject views with respect to their personal feelings of the study outcome, ranging from feelings of disappointment (even with improved ICD/ACD) to success (as one participant developed a continuing at-home program).

Assessment of two more variables, blood flow during exercise and endothelial function, would have provided us additional data and possibly more insight into the mechanisms causing increased ICD and ACD in this population. Blood flow during exercise could not be measured as it is difficult to perform duplex ultrasounds and acquire accurate images on participants in motion, particularly on a treadmill. Regarding endothelial function, current non-invasive methods of measurement use prolonged suprasystolic cuff occlusion of the limbs (Parker, Ridout, & Proctor, 2006). Although this method is accurate, it is not reasonable for individuals with T2D and PAD who are

likely to suffer from neuropathy (Canadian Diabetes Association, 2008), resting leg pain (Beard, 2000) and venous insufficiency (Donnelly, Emslie-Smith, Gardner, & Morris, 2000) which can make the procedure painful and unbearable. Also, prolonged occlusion of the venous system and/or the use of an improperly fitted cuff can cause venous trauma and initiate inflammation and phlebitis (blood clot formation) (National Institutes of Health, 2011b), which in some circumstances can lead to a pulmonary embolism (National Institutes of Health, 2011a).

Another limitation of the study was that the dosage of and time of injection of insulin were not monitored. Insulin has vasoactive effects and can act as either a vasodilator or vasoconstrictor (Eringa, Stehouwer, Merlijn, Westerhof, & Sipkema, 2002; Verma, Yao, Stewart, Dumont, Anderson et al., 2001) which can cause it to interfere with arterial diameters and subsequent measurement and analysis.

## **2.7 Conclusion**

Bilateral lower extremity isometric exercise training can increase both ICD and ACD in individuals with concurrent T2D and PAD, however, increased local blood flow cannot be identified as the mechanism responsible for the improvement. Further research is needed in order to replicate these preliminary findings, and to determine the processes that cause increases in ICD and ACD following bilateral lower extremity isometric exercise training. Future studies involving bilateral lower extremity isometric exercise

and ICD/ACD should examine the combined blood flow of all the infrageniculate arteries (rather than isolating one) and mitochondrial respiration.

## **2.8 Clinical Relevance**

The findings of the present study provide a foundation for future large-scale studies designed to better understand the effects of bilateral lower extremity isometric training on PAD and its complications in persons with T2D. Although still in the early stages of investigation, the results of this research will serve as a basis for future studies designed to investigate blood flow and isometric exercise, potentially providing an alternative treatment option for individuals suffering from PAD and claudication. The practice of bilateral lower extremity isometric training may also promote better T2D management, as this form of exercise may increase the locomotive ability necessary for the aerobic exercise programs that help control hyperglycemia.

## Reference List

- Alessio, H.M., Hagerman, A.E., Fulkerson, B.K., Ambrose, J., Rice, R.E., & Wiley, R.E. (2000). Generation of reactive oxygen species after exhaustive aerobic and isometric exercise. *Medicine and Sport Science*, 32, 1576-1581.
- American College of Cardiology/American Heart Association Task Force. (2004). ACC/AHA guidelines for the management of patients with ST-elevation myocardial infarction. *Circulation*, 110, 588-636
- American College of Sports Medicine. (2010). ACSM's guidelines for exercises testing and prescription. Philadelphia, Lippincott Williams & Wilkins.
- American Diabetes Association (2003). Peripheral arterial disease in people with diabetes. *Diabetes Care*, 26, 3333-3341.
- American Heart Association. (2008). PAD risk factors and possible complications. Retrieved from <http://www.americanheart.org/presenter.jhtml?identifier=3020256>.
- Beard, J.D. (2000). Chronic lower limb ischemia. *Western Journal of Medicine*, 173, 60-63.
- Beckman, J., Higgins, C., & Gerhard-Herman, M. (2006). Automated oscillometric determination of the ankle-brachial index provides accuracy necessary for office practice. *Hypertension*, 47, 35-38.

- Benchimol, A., Bernard, V., Pillois, X., Hong, N., Benchimol, D., & Bonnet, J. (2004). Validation of a new method of detecting peripheral arterial disease by determination of ankle-brachial index using an automatic blood pressure device. *Angiology*, 55, 127-134.
- Bennett, M. (2006). Vascular smooth muscle cell senescence in atherosclerosis. *Cardiovascular Research*, 72, 9-17.
- Bennett, M., Macdonald, K., Chan, S., Boyle, J.J., & Weissberg, P.L. (1998). Cooperative interactions between RB and p53 regulate cell proliferation, cell Senescence, and apoptosis in human vascular smooth muscle cells from atherosclerotic plaques. *Circulation Research*, 82, 702-712.
- Bernstein, E. & Fronck, A. (1982). Current status of non-invasive tests in the diagnosis of peripheral arterial disease. *Surgical Clinics of North America*, 62, 473-487.
- Brevetti, G., Silvestro, A., Di Giacomo, S., Bucur, R., Di Donato, A., Schiano, V., & Scopacasa, F. (2003). Endothelial dysfunction in peripheral arterial disease is related to increase in plasma markers of inflammation and severity of peripheral circulatory impairment but not to classic risk factors and atherosclerotic burden. *Journal of Vascular Surgery*, 38, 374-379.
- Canadian Diabetes Association. (2004). Signs and symptoms of hypoglycemia. Retrieved from [http://www.diabetes.ca/Files/kwd\\_signs.pdf](http://www.diabetes.ca/Files/kwd_signs.pdf)
- Canadian Diabetes Association. (2008). Canadian journal of diabetes: Canadian diabetes association 2008 clinical practice guidelines for the prevention and management of diabetes in Canada.



- Chen, M.X. & Moe, S.M. (2003). Arterial calcification in diabetes. *Current Diabetes Reports*, 3, 28-32.
- Cooper, C.E. & Brown, G.C. (2008). The inhibition of mitochondrial cytochrome oxidase by the gases carbon monoxide, nitric oxide, hydrogen cyanide and hydrogen sulfide: chemical mechanism and physiological significance. *Journal of Bioenergetics and Biomembranes*, 40, 533-539.
- Costa, F. & Biaggioni, I. (1998). Role of nitric oxide in adenosine-induced vasodilation in humans. *Hypertension*, 31, 1061-1064.
- Criqui, M.H., Ninomiya, J.K., Wingard, D.L., Ji, M., & Fronek, A. (2008). Progression of peripheral arterial disease predicts cardiovascular disease morbidity and mortality. *Journal of the American College of Cardiology*, 52, 1736-1742.
- Donnelly, R., Emslie-Smith, A., Gardner, I.D., & Morris, A.D. (2000). ABC of arterial and venous disease: Vascular complications of diabetes. *British Medical Journal*, 320, 1062-1066.
- Eberhardt, R.T. (2003). *Peripheral arterial disease: Diagnosis and treatment*. Totowa, New Jersey, Human Press.
- Eringa, E.C., Stenhouwer, C.D., Merlijn, T., Westerhof, N., & Sipkema, P. (2002). Physiological concentrations of insulin induce endothelin-mediated vasoconstriction during inhibition of NOS or PI3-kinase in skeletal muscle arterioles. *Cardiovascular Research*, 56, 464-471.

- Faglia, E., Favales, F., Quarantiello, A., Calia, P., Clelia, P., Brambilla, G., Rampoldi, A., et al. (1998). Angiographic evaluation of peripheral arterial occlusive disease and its role as a prognostic determinant for major amputation in diabetic subjects with foot ulcers. *Diabetes Care*, 21, 625-630.
- Gardner, A., Skinner, J., Cantwell, B., & Smith, L. (1991). Progressive versus single-stage treadmill tests for evaluation of claudication. *Medicine and Science in Sports and Exercise*, 23, 402-408.
- Giachelli, C.M. (2004). Vascular calcification mechanisms. *Journal of the American Society of Nephrology*, 15, 2959-2964.
- Herlihy, J.T., Bockman, E.L., Berne, R.M., & Rubio, R. (1976). Adenosine relaxation of isolated vascular smooth muscle. *American Journal of Physiology*, 230, 1239-1243.
- Hiatt, W., Wolfel, E., Meier, R., & Regensteiner, J. (1994). Superiority of treadmill walking exercise versus strength for patients with peripheral arterial disease. Implications for the mechanism of the training response. *Circulation*, 90, 1866-1874.
- Hiatt, W., Nawaz, D., Regensteiner, J., & Hossack, K. (1998). The evaluation of exercise performance in patients with peripheral vascular disease. *Journal of Cardiopulmonary Rehabilitation and Prevention*, 12, 525-532.

- Hirsch, A.T., Criqui, M.H., Treat-Jacobson, D., Regensteiner, J.G., Creager, M.A., Olin, J.W., Krook, S.H., et al. (2001). Peripheral arterial disease detection, awareness, and treatment in primary care. *Journal of the American Medical Association*, 286, 1317-1324.
- Kennedy, J., Hirshman, H., Gervin, E., Ocel, J., Forse, R., Hoeing, S. et al. (1999). Acute exercise induces GLUT4 translocation in skeletal muscle of normal human subjects and subjects with type 2 diabetes. *Diabetes*, 48, 1192-1197.
- Kimura, M., Ueda, K., Goto, C., Jitsuiki, D., Nishioka, K., Umemura, T., Noma, K., et al. (2007). Repetition of ischemic preconditioning augments endothelium-dependent vasodilation in humans: Role of endothelium-derived nitric oxide and endothelial progenitor cells. *Atherosclerosis, Thrombosis, and Vascular Biology*, 27, 1403-1410.
- Li, H. & Fostermann, U. (2000). Nitric oxide in the pathogenesis of vascular disease. *Journal of Pathology*, 190, 244-254.
- Lind, A. & Williams, C. (1979). The control of blood flow through human forearm muscles following brief isometric contractions. *Journal of Applied Physiology*, 288, 529-549.
- McGowan, C., Levy, A., Millar, P., Guzman, J., Morillo, C., McCartney, N., & Macdonald, M. (2006a). Acute vascular responses to isometric handgrip exercise and effects of training in persons medicated for hypertension. *American Journal of Physiology*, 291, 4, 1797-1802.

- McGowan, C., Visocchi, A., Faulkner, M., Verdyun, R., Rakobowchuk, M., Levy, A. et al. (2006b). Isometric hand grip training improves local flow-mediated dialation in medicated hypertensives. *European Journal of Applied Physiology*, 98, 355-362.
- McGowan, C., Levy, A., McCartney, N., & Macdonald, M. (2007). Isometric handgrip training does not improve flow-mediated dilation in subjects with normal blood pressure. *Clinical Science*, 112, 403-409.
- McLafferty, R.B., Moneta, G.L., Taylor, L.M. Jr., & Porter, J.M. (1997). Ability of ankle-brachial index to detect lower-extremity atherosclerotic disease progression. *Archives of Surgery*, 132, 836-840.
- Murrant, C. (2008). Structural and functional limitations of the collateral circulation in peripheral artery disease. *Journal of Physiology*, 586, 5845-5846.
- National Institutes of Health. (2011a). What is deep vein thrombosis. Retrieved from [http://www.nhlbi.nih.gov/health/dci/Diseases/Dvt/DVT\\_WhatIs.html](http://www.nhlbi.nih.gov/health/dci/Diseases/Dvt/DVT_WhatIs.html)
- National Institutes of Health. (2011b). Who is at risk for deep vein thrombosis. Retrieved from [http://www.nhlbi.nih.gov/health/dci/Diseases/Dvt/DVT\\_WhoIsAtRisk.html](http://www.nhlbi.nih.gov/health/dci/Diseases/Dvt/DVT_WhoIsAtRisk.html)
- Oguri, M., Adachi, H., Ohno, T., Oshima, S., & Kurabayashi, M. (2009). Effect of a single bout of moderate exercise on glucose uptake in type 2 diabetes mellitus. *American Journal of Cardiology*, 53, 8-14.

- Parker, B., Ridout, S., & Proctor, D. (2006). Age and flow-mediated dilation: A comparison of dilatory responsiveness in the brachial and popliteal arteries. *American Journal of Physiology- Heart and Circulatory Physiology*, 3043-3049.
- Parker, B., Smithmyer, S., Jarvis, S., Ridout, S., Pawelczyk, J., & Proctor, D. (2006). Evidence for reduced sympatholysis in leg resistance vasculature of healthy older women. *American Journal of Physiology*, 292, H1148-H1156.
- Peters, P.G., Alessio, H.M., Hagerman, A.E., Ashton, T., Nagy, S., & Wiley, R.L. (2006). Short-term isometric exercise reduces systolic blood pressure in hypertensive adults: Possible role of reactive oxygen species. *International Journal of Cardiology*, 110, 199-205.
- Primates, P., Falaschetti, E., Gupta, S., Marmot, M., & Poulter, N. (2001). Association between smoking and blood pressure. *Hypertension*, 37, 187-193.
- Ross, R., Wight, T.N., Strandess, E., & Thiele, B. (1984). Cell constitution and characteristics of advanced lesions of the superficial femoral artery. *American Journal of Pathology*, 114, 79-93.
- Statistic Canada (2010). Diabetes. Retrieved from <http://www.statcan.gc.ca/pub/82-229-x/2009001/status/dia-eng.htm>
- Thompson, B., Fadia, T., Pincivero, D., & Scheuermann, B. (2007). Forearm blood flow responses to fatiguing isometric contractions in women and men. *American Journal of Physiology*, 293, 805-812.

- Treat-Jacobson, D., Bronas, U., & Leon, A. (2009). Efficacy of arm-ergometry versus treadmill exercise training to improve walking distance in patients with claudication. *Vascular Medicine*, *14*, 203-213.
- Verma, S. Yao, L., Stewart, D.J., Dumont, A.S., Anderson, T.J., & McNeill, J.H. (2001). Endothelin antagonism uncovers insulin-mediated vasorelaxation in vitro and in vivo. *Hypertension*, *37*, 328-333.
- Weatherley, B., Chambless, L., Heiss, G., Catellier, D., & Ellison, C. (2006). The reliability of the ankle-brachial index in the Atherosclerosis Risk in Communities (ARIC) study and the NHLBI Family Heart Study (FHS). *BMC Cardiovascular Disorders*, *6*, 7.
- Weir, G. & Bonner-Weir, S. (2004). Five stages of evolving beta-cell dysfunction during progression to diabetes. *Diabetes*, *53*, 16-21.
- Wiles, J., Coleman, D., & Swaine, I. (2009). The effects of performing isometric training at two exercise intensities in healthy young males. *European Journal of Applied Physiology*.
- Winnick, J., Sherman, W., Habash, L., Stout, M., Failla, M., Belury, M. et al. (2008). Short-term aerobic exercise in obese humans with type 2 diabetes mellitus improves whole-body insulin sensitivity through gains in peripheral, not hepatic insulin sensitivity. *Journal of Clinical Endocrinology & Metabolism*, *93*, 771-778.
- World Health Organization. (2008). Diabetes fact sheet. Retrieved from <http://www.who.int/mediacentre/factsheets/fs312/en/>

## **Tables**

Table 1.

*Summary of the Differences Between Type 1, Type 2 and Gestational Diabetes*

Characteristics	Type 1	Type 2	Gestational
Alternate Name(s)	Juvenile-onset, Insulin-dependent	Adult-onset, Non-insulin dependent	(none)
Prevalence	5-10% of diabetics	90-95% of diabetics	4% of pregnant women
Time of Onset	Before age 20	After age 40	During pregnancy
Pathology	The body does not produce insulin	The body is resistant to insulin	The body is resistant to insulin

*Note.* The information is from “Diabetics Guide to Health and Fitness”, by K. Berg, 1986, Champaign, IL, Life Enhancement Publications; and “Gestational Diabetes: Preventing Complications in Pregnancy”, by the Canadian Diabetes Association, 2009.



Table 2.1

*Participant Characteristics: Age, Sex and Race*

Participant	Age (years)	Sex	Race
1	70	male	Caucasian
2	60	male	Caucasian
3	63	male	Caucasian
4	68	male	Caucasian

Table 2.2

*Participant Characteristics: Peripheral Arterial Disease-Related*

Participant	Age diagnosed	Pain medication	Hypertension medication	Hyperlipidemia medication	Anti-coagulation medication
1	unknown	No	Yes	Yes	Yes
2	58	No	Yes	Yes	Yes
3	47	No	Yes	Yes	Yes
4	unknown	No	Yes	Yes	Yes

Table 2.3

*Participant Characteristics: Type 2 Diabetes-Related*

Participant	Age diagnosed	Oral medications	Insulin
1	39	Yes	began at age 39; ended at age 68
2	54	Yes	Never
3	47	Yes	began at age 60 and continuing
4	52	Yes	began at age 59 and continuing

Table 2.4

*Participant Characteristics: Physical Activity History*

Participant	High school sports	Post-high school (age 18-50 years)	Golden years (age 50+ years)
1	Football team, basketball team, wrestling team	Dancing (1d/wk)	Dancing (1d/wk)  1 hr walk (2d/wk)  1 hr water aerobics (2d/wk)
2	None	Pick-up hockey (1d/wk)	1 hr walk (2d/wk)
3	Football team	Recreational baseball (1 d/wk)	1 hr water aerobics (5d/wk)
4	None	Physically demanding jobs (5d/wk)	Physically demanding jobs (5d/wk until age 63)  1 hr walk (3d/wk)  2 hr walk (4d/wk)

*Note.* Hour (hr), day (d), week (wk)

Table 3.1

*Raw Data: Popliteal Artery Diameters (cm)*

Participant	Pre-Intervention				Post-Intervention			
	Pre-Exercise		Post-Exercise		Pre-Exercise		Post-Exercise	
	Right	Left	Right	Left	Right	Left	Right	Left
1	0.80	0.81	0.79	0.80	0.79	0.79	0.83	0.83
2	0.81	0.79	1.22	0.87	0.80	0.79	0.78	0.77
3	0.56	0.55	0.5	0.54	0.58	0.59	0.59	0.59
4	0.73	0.74	0.7	0.78	0.71	0.74	0.70	0.76

Table 3.2

*Raw Data: Popliteal Artery Timed-Average Mean Velocity (cm/sec)*

Participant	Pre-Intervention				Post-Intervention			
	Pre-Exercise		Post-Exercise		Pre-Exercise		Post-Exercise	
	Right	Left	Right	Left	Right	Left	Right	Left
1	1.10	2.66	3.22	3.22	1.09	1.57	3.93	2.20
2	4.65	6.54	34.90	16.63	6.81	4.47	10.38	12.71
3	10.24	14.86	25.37	44.50	19.57	15.43	33.48	23.34
4	6.32	5.12	8.06	5.97	6.28	3.85	3.74	6.01

Table 3.3

*Raw Data: Resting Ankle-Brachial Index*

Participant	Pre-Intervention		Post-Intervention	
	Right Leg	Left Leg	Right Leg	Left Leg
1	1.10	1.13	1.24	1.23
2	0.83	1.08	0.81	1.00
3	-	-	-	-
4	0.78	0.77	0.67	0.73

*Note.* Ankle-brachial indices could not be determined for Participant #3 due to 'error display' on oscillometer, and Participants #1 and 2 may have elevated ankle-brachial indices due to arterial calcification.

Table 3.4

*Raw Data: Pre & Post-Exercise Session Blood Glucose Measurements (mM)*

Session	Participant #1		Participant #2		Participant #3		Participant #4	
	<i>Pre</i>	<i>Post</i>	<i>Pre</i>	<i>Post</i>	<i>Pre</i>	<i>Post</i>	<i>Pre</i>	<i>Post</i>
1	7.7	6.4	11.1	16.9	8.2	8.9	11.8	10.9
2	10.5	11.6	13.4	13.0	6.0	5.7	6.2	4.9
3	7.7	6.9	12.4	16.2	6.7	6.7	6.9	8.2
4	5.9	4.7	11.0	9.8	6.8	7.8	8.9	7.5
5	5.2	4.5	9.7	10.8	6.0	6.2	9.0	7.7
6	9.8	9.8	17.1	13.5	8.3	8.3	7.9	6.1
7	11.3	10.1	17.8	18.6	7.1	7.2	12.1	10.3
8	8.6	8.1	16.9	13.4	10.8	7.9	8.2	7.1
9	6.4	4.9	12.7	12.0	8.1	6.1	6.6	6.9
10	10.2	8.0	18.1	17.8	11.1	11.4	9.9	9.7
11	7.8	7.8	14.1	15.5	5.7	5.9	7.3	5.7
12	12.6	15.6	13.1	12.0	4.4	4.4	6.3	5.7
13	6.1	5.9	12.8	10.9	6.1	6.8	9.1	8.5
14	7.1	5.4	10.9	10.9	5.5	5.0	8.6	9.1
15	10.2	9.5	12.5	9.3	8.8	8.2	9.2	10.6
16	12.0	9.1	11.1	11.9	10.1	11.3	10.7	10.4
17	12.0	15.0	-	-	8.2	13.8	12.1	12.3
18	8.8	11.4	-	-	6.5	5.8	7.0	6.9
19	7.5	8.6	-	-	6.6	6.8	8.1	7.3
20	11.9	10.3	-	-	5.8	5.2	-	-

Table 4.1

*Results Table: Initial Claudication Distance (ICD)/Absolute Claudication Distance (ACD) (mi)*

	<i>Pre- Intervention</i>	<i>Pre- Intervention</i>	<i>Post- Intervention</i>	<i>Post- Intervention</i>
<b>Participant</b>	<b>ICD</b>	<b>ACD</b>	<b>ICD</b>	<b>ACD</b>
1	0.07	0.18	0.17	0.35
2	0.20	0.39	0.36	0.53
3	0.09	0.23	0.20	0.26
4	0.05	0.17	0.11	0.25

Table 4.2

*Results Table: Pre-Exercise Blood Flow (ml/sec)*

	<i>Pre- Intervention</i>	<i>Pre- Intervention</i>	<i>Post- Intervention</i>	<i>Post- Intervention</i>
<b>Participant</b>	<b>Right Leg</b>	<b>Left Leg</b>	<b>Right Leg</b>	<b>Left Leg</b>
1	0.55	1.37	0.55	0.79
2	2.46	3.29	3.42	2.14
3	2.52	3.66	5.17	4.08
4	2.72	2.20	2.56	1.65

Table 4.3

*Results Table: Post-Exercise Blood Flow (ml/sec)*

	<i>Pre- Intervention</i>	<i>Pre- Intervention</i>	<i>Post- Intervention</i>	<i>Post- Intervention</i>
<b>Participant</b>	<b>Right Leg</b>	<b>Left Leg</b>	<b>Right Leg</b>	<b>Left Leg</b>
1	1.58	1.62	2.18	1.16
2	4.08	10.11	4.96	6.07
3	5.81	10.19	8.85	6.17
4	3.85	2.85	1.44	2.73

## **Figures**

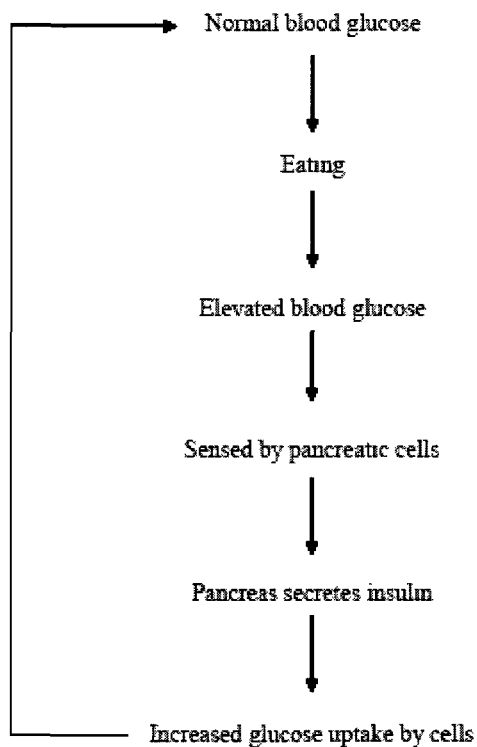

*Figure 1.* The Negative Feedback System of Control for Blood Glucose. The blood glucose concentration is elevated by eating and this elevation is sensed by pancreatic cells which secrete insulin in response to the elevation. The secreted insulin influences increased glucose uptake by cells and, in turn, reduces and returns the blood glucose concentration to normal.

---

*Note.* The information is from "Physiology of Stress", by M. Aserita, 1985, New York, NY, Human Sciences Press.

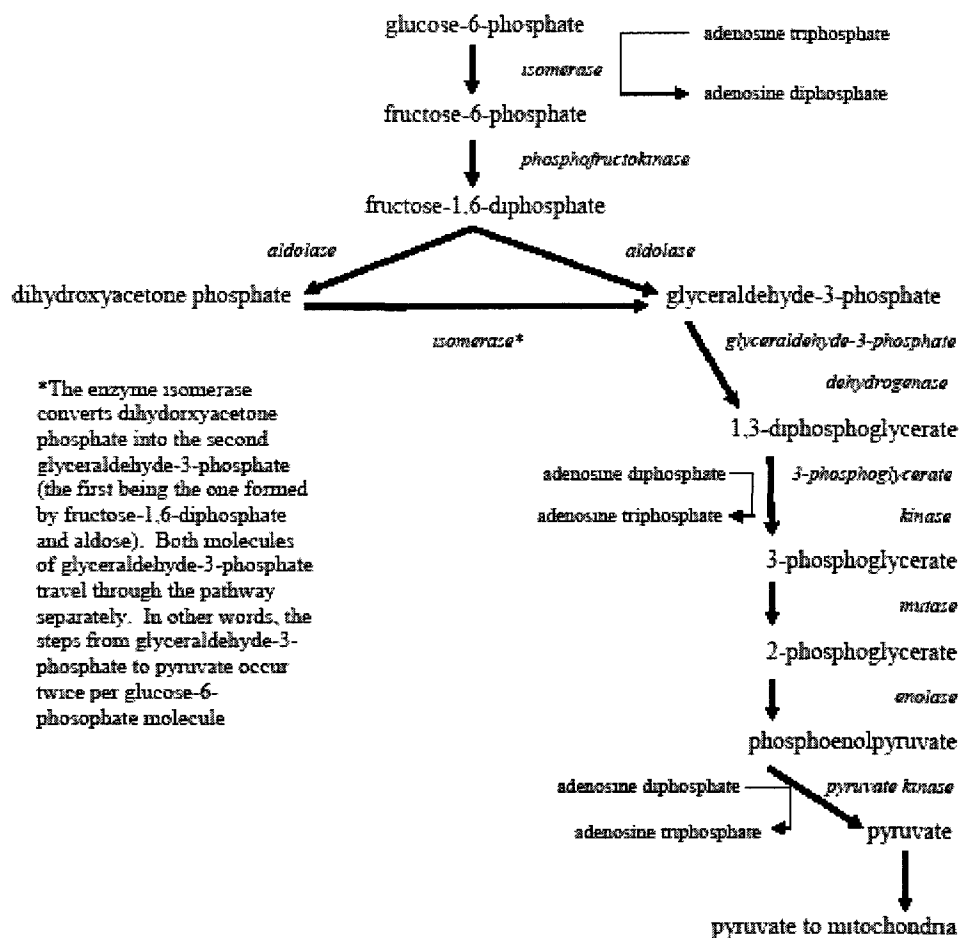

**Figure 2.** Glycolysis in the Sacroplasm of the Beta Cell. The figure depicts the pathway by which pyruvate is created from glucose-6-phosphate, and the enzymes (in *italics*) acting on each new molecule in the pathway. Also shown is the energy compound, adenosine triphosphate and when it is produced (from adenosine diphosphate) or used (broken down to adenosine diphosphate).

*Note.* The information is from "Exercise Physiology. Theory and Application to Fitness and Performance", by S. Powers & E. Howley, 2009, New York, NY, McGraw-Hill.



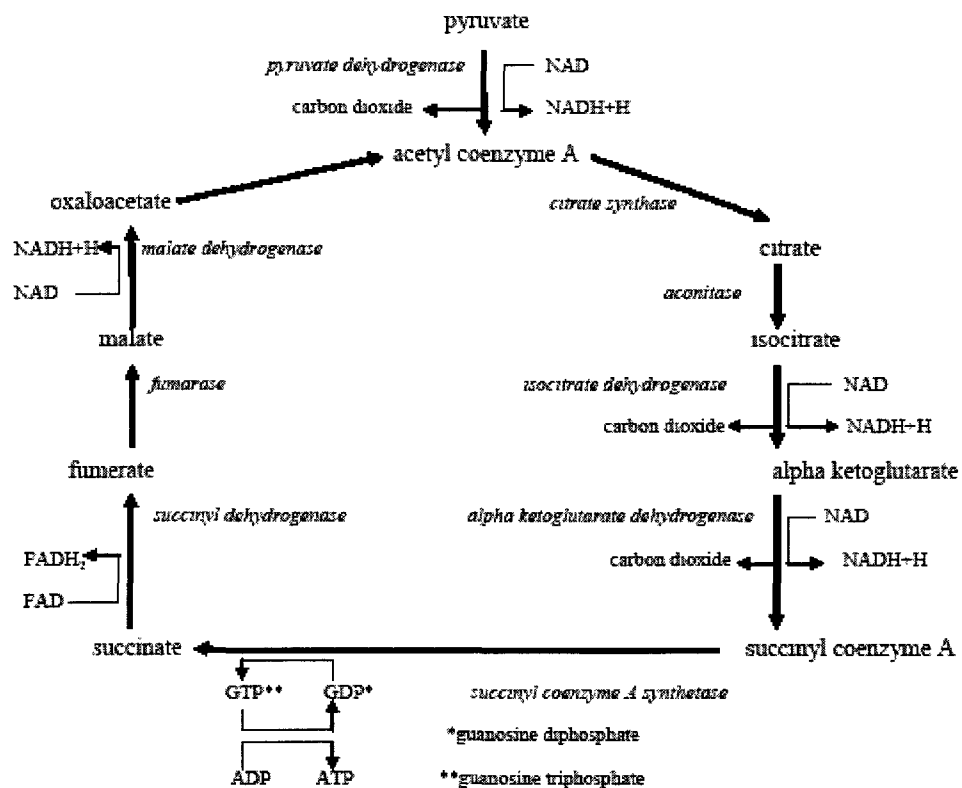

*Figure 3.* The Krebs's Cycle in a Mitochondrion of the Cell. The figure depicts the pathway by which pyruvate is converted into different molecules allowing for the production of the energy compound adenosine triphosphate (ATP) and reducing equivalents nicotinamide adenine dinucleotide with 2 hydrogen ions (NADH+H) and flavin adenine dinucleotide with 2 hydrogen ions (FADH<sub>2</sub>) from the compounds adenosine diphosphate (ADP), nicotinamide adenine dinucleotide (NAD) and flavin adenine dinucleotide (FAD) respectively. The reducing equivalents will travel to the electron transport chain to produce more ATP. Also shown are the enzymes (in *italics*) involved in the reactions.

*Note.* The information is from "Exercise Physiology: Theory and Application to Fitness and Performance", by S. Powers & E. Howley, 2009, New York, NY, McGraw-Hill.

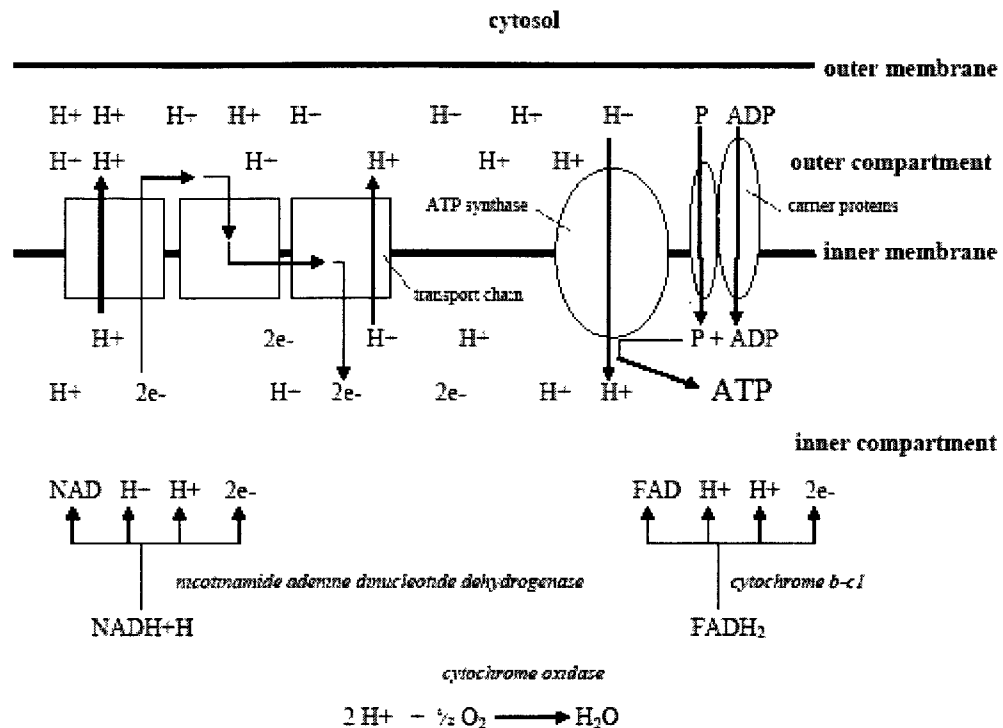

*Figure 4.* The Electron Transport Chain in a Mitochondrion. The figure depicts the breakdown of the reducing equivalents nicotinamide adenine dinucleotide and 2 hydrogen ions (NADH+H) and flavin adenine dinucleotide and 2 hydrogen ions (FADH<sub>2</sub>) by their respective enzymes (in *italics*). Also illustrated are electrons (2e<sup>-</sup>) traveling through the transport chain providing the energy to pump hydrogen ions (H<sup>+</sup>) into the outer compartment of the mitochondrion. The H<sup>-</sup> is brought back into the inner compartment using adenosine triphosphate (ATP) synthase whose action is coupled with the actions of the carrier proteins which transport phosphate ions (P) and adenosine diphosphate molecules (ADP). The enzyme cytochrome oxidase catalyzes the reaction of water (H<sub>2</sub>O) production.

*Note.* The information is from "Exercise Physiology: Theory and Application to Fitness and Performance", by S. Powers & E. Howley, 2009, New York, NY, McGraw-Hill.

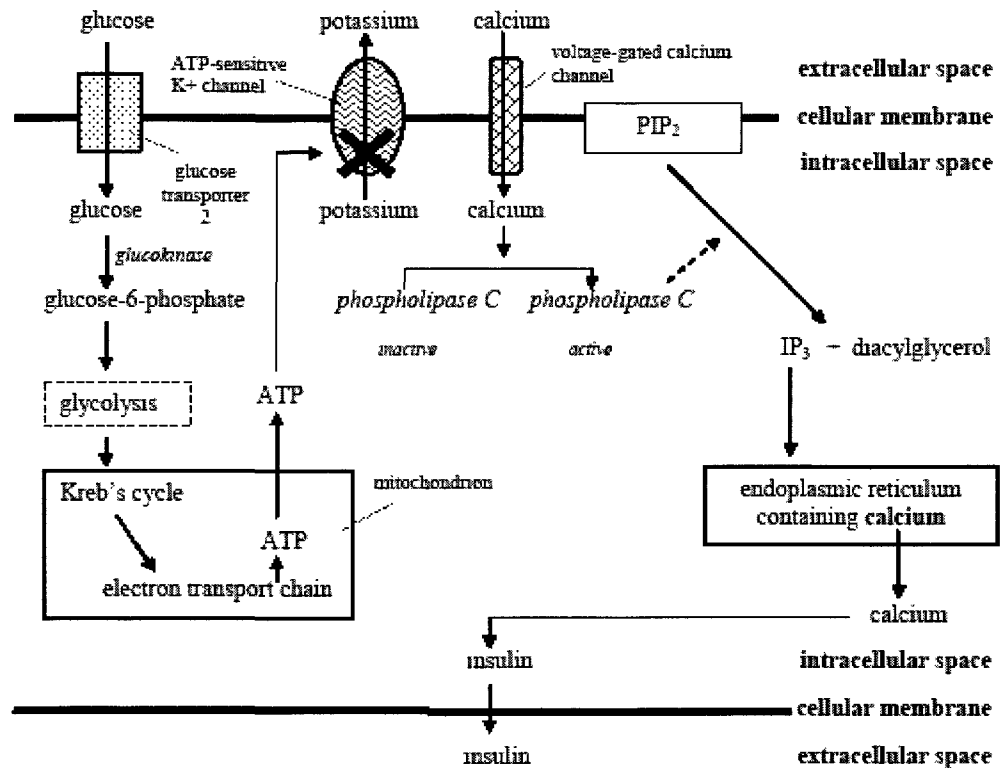

**Figure 5. Beta Cell Glucose Uptake and Insulin Release.** The figure depicts glucose entry into the beta cell (via glucose transporter 2), and conversion into adenosine triphosphate (ATP) which inhibits the ATP-sensitive potassium (K<sup>+</sup>) channel, an action that causes cell membrane depolarization and the opening of the voltage-gated calcium channel allowing calcium influx. Calcium activates the enzyme phospholipase C which acts on phosphatidylinositol-4,5-bisphosphate (PIP<sub>2</sub>) to cleave it into inositol-1,4,5-triphosphate (IP<sub>3</sub>) and diacylglycerol. IP<sub>3</sub> increase the release of calcium from the endoplasmic reticulum and this influences the process of insulin exocytosis from the cell and into the extracellular space.

*Note.* This information is from "Glucose as a Regulator in Glucose Transport Activity and Glucose-Transporter mRNA in Hamster Beta-Cell Lines", by N. Inagaki, K. Yasuda, G. Inoue, Y. Okamoto, H. Yano, Y. Someya, et al. 1992, *Diabetes*, 41, 592-597; and "Voltage Noise Measurements across the Pancreatic Beta-Cell Membrane: Calcium Channel Characteristics", by I. Atwater, C. Dawson, G. Eddlestone, & E. Rojas. 1981. *Journal of Physiology*, 314, 195-212.

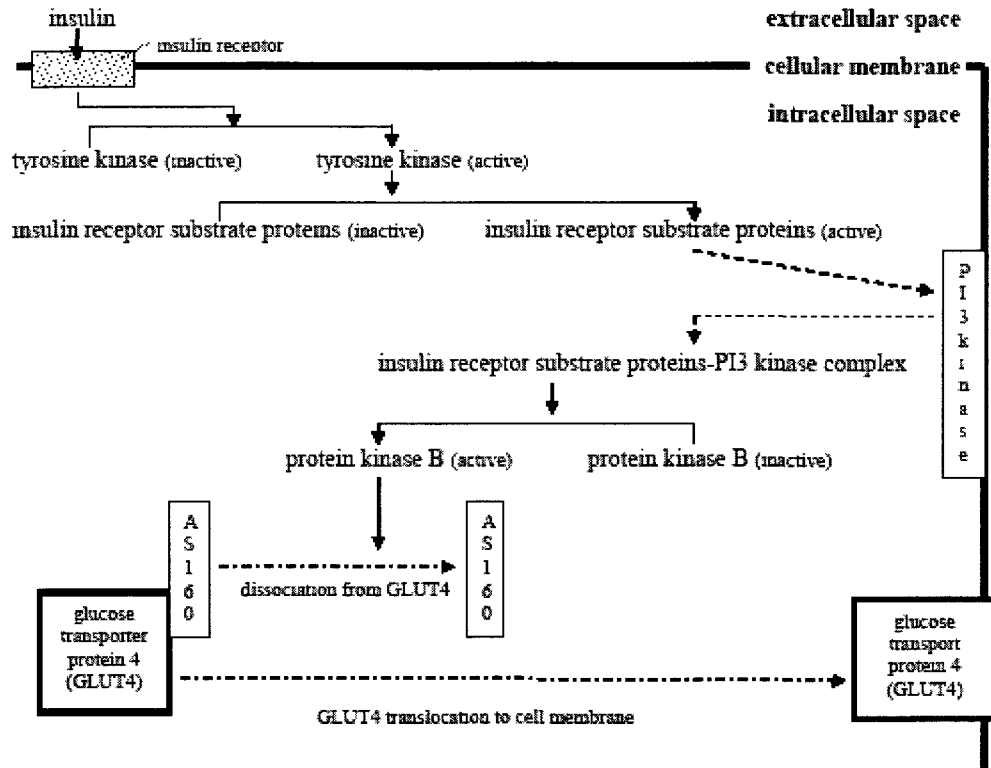

**Figure 6. Insulin-Stimulated GLUT4 Translocation in a Muscle Cell.** When insulin binds to the insulin receptor on the muscle cell, it activates tyrosine kinase which activates insulin receptor substrate proteins. The insulin receptor substrate proteins bind to and subsequently activate phosphatidylinositol-3 kinase and this action activates protein kinase B. Protein kinase B causes the protein AS160 to dissociate from the glucose transporter protein 4 (GLUT4). When bound to GLUT4, AS160 inhibits GLUT4 movements. Once AS160 is dissociated from GLUT4, GLUT4 translocation is able to occur.

*Note.* This information is from "Mechanisms of High-Glucose/Insulin-Mediated Desensitization of Acute Insulin-Stimulated Glucose Transport of Akt Activation", by K. Robinson & M. Buse, 2008, *American Journal of Physiology, Endocrinology & Metabolism*, 294, 870-881; and "Models for Regulation by AMPK/SNF1 of Glucose Uptake in Muscle and Gene Expression in Yeast", by G. Hardie, 2002, *Nature Review Molecular Cell Biology*, 8, 774-785.

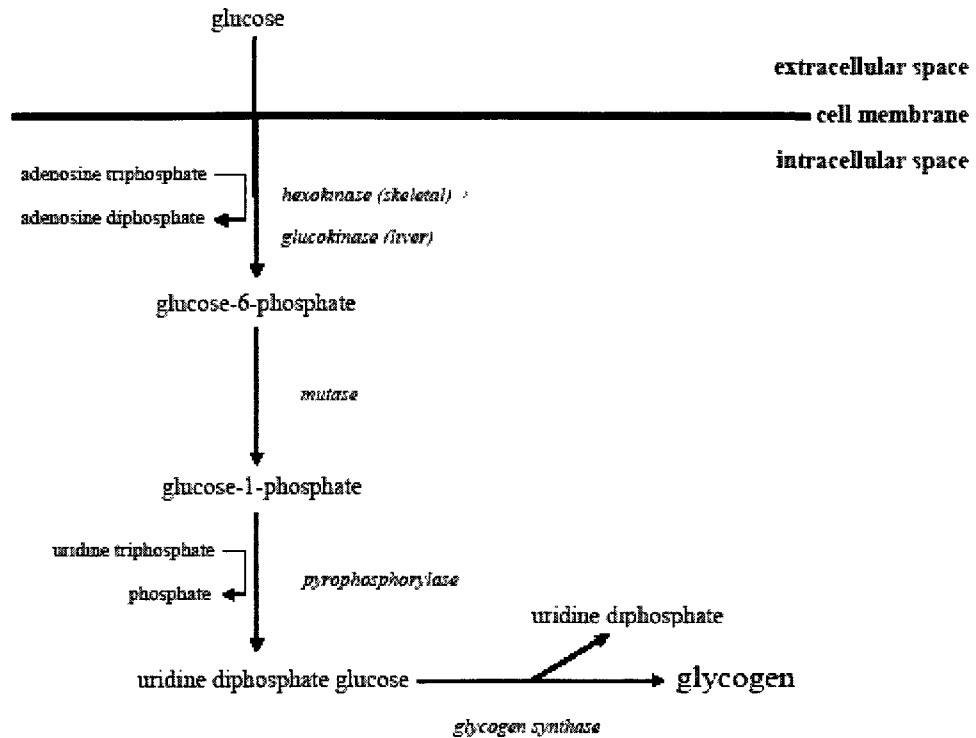

**Figure 7. Glycogenesis in Skeletal Muscle and Liver Cells.** Glucose enters the cell and is acted on by the enzyme (in *italics*) hexokinase (in the skeletal muscle cell) or glucokinase (in the liver cell) which uses energy from adenosine triphosphate to produce glucose-6-phosphate. Glucose-6-phosphate is converted into glucose-1-phosphate by mutase. Pyrophosphorylase catalyzes the reaction to produce uridine diphosphate from glucose-1-phosphate. Glycogen is then produced from uridine diphosphate via the enzyme, *glycogen synthase*.

*Note.* This information is from "Biology: Concepts and Connections (6<sup>th</sup> ed)", by N. Campbell, J. Reece, M. Taylor, E. Simon & J. Dickey, 2009, San Francisco, Pearson Education, Inc.

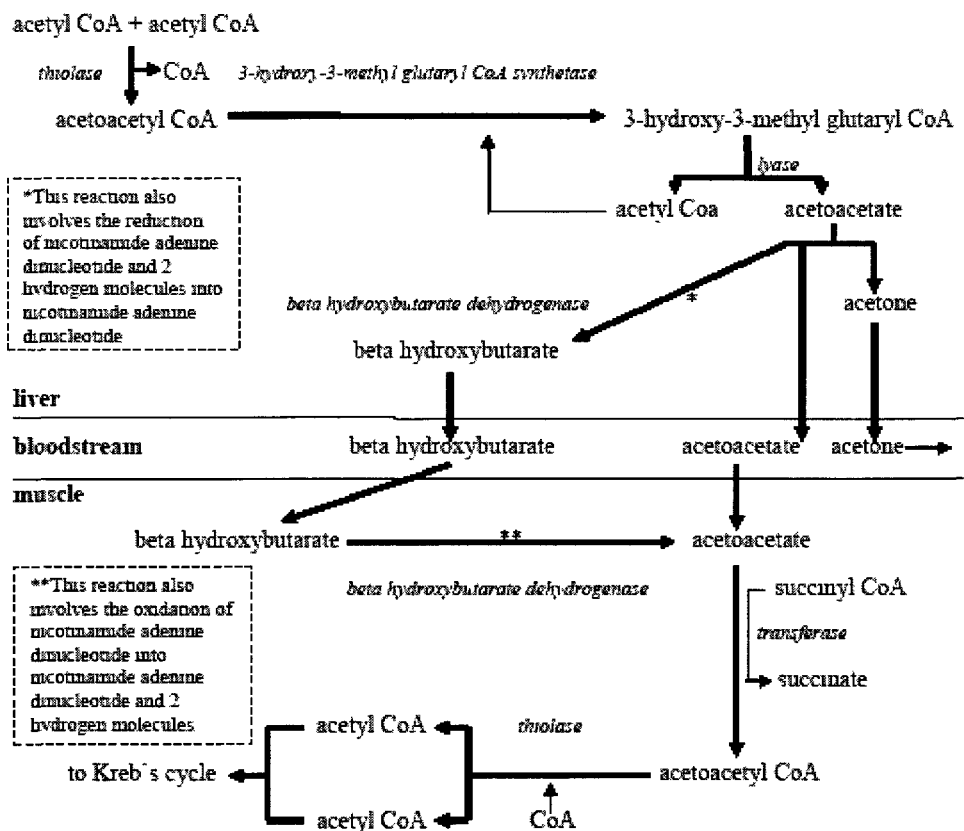

**Figure 8 Ketone Body Formation in the Liver and Breakdown in Skeletal Muscle** The illustration depicts the conversion of 2 molecules of acetyl coenzyme A (CoA) into the ketone bodies beta hydroxybutyrate, acetoacetate and acetone along with the enzymes (in *italics*) that catalyze each reaction. Acetone travels through the blood stream to the kidneys to be expelled while beta hydroxybutyrate and acetoacetate enter the muscle cell to be broken down into acetyl CoA and enter the Krebs cycle.

*Note* This information is from "The Mechanism of Ketone-Body Formation from Butyrate in Rat Liver" by J Hird & R. Symons, 1962 *Biochemical Journal*, 84 212-216 and 'Aspects of Ketogenesis: Control and Mechanism of Ketone-Body Formation in Isolated Rat-Liver Mitochondria' by M. Lopes-Carodosa, I Mulder P Hermans S van den Burgh, W Klazniga, E de Vries-Akkerman, et al. 1975 *Molecular and Cellular Biochemistry* 9, 155-173, and "Essentials of Exercise Physiology (3<sup>rd</sup> Ed)", by W McArdle F Katch & V Katch, 2006, Baltimore, MD, Lippincott Williams & Wilkins

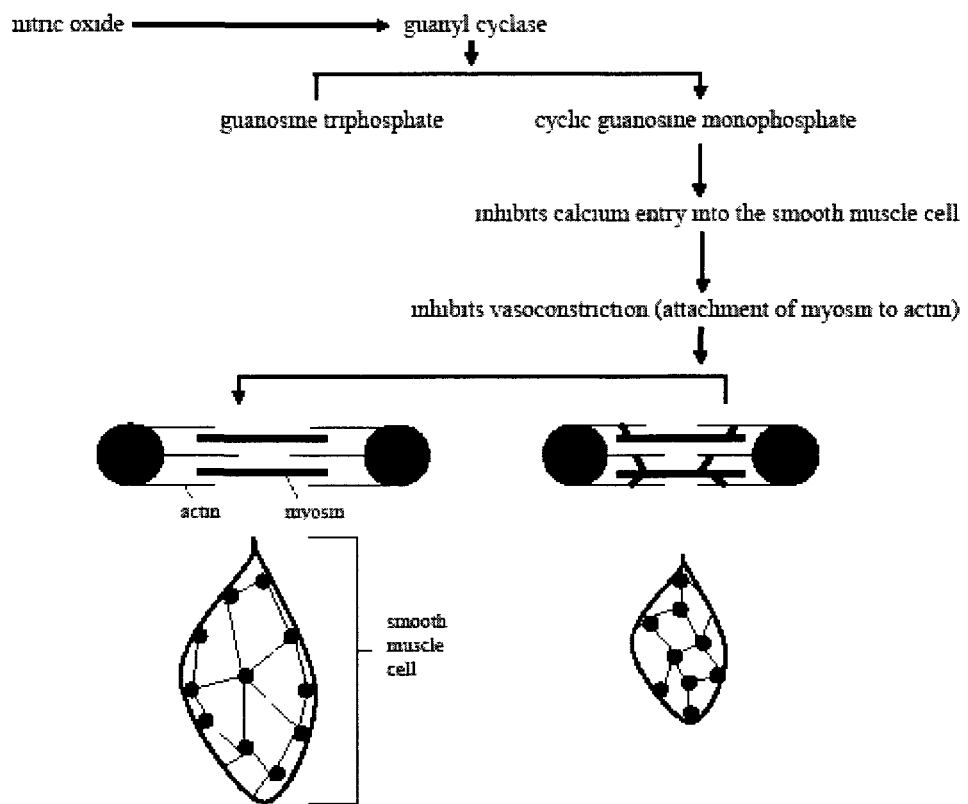

*Figure 9* Vasodilation Caused by the Effect of Nitric Oxide in a Smooth Muscle Cell Nitric oxide enters the smooth muscle cell and activates guanyl cyclase which converts guanosine triphosphate into cyclic guanosine monophosphate Cyclic guanosine monophosphate inhibits calcium entry into the smooth muscle cell which inhibits vasoconstriction by preventing myosin attachment to actin thus causing vasodilation.

*Note* This information is from 'Exercise Physiology Theory and Application to Fitness and Performance', by S Powers & E Howley, 2009 New York, NY, McGraw-Hill

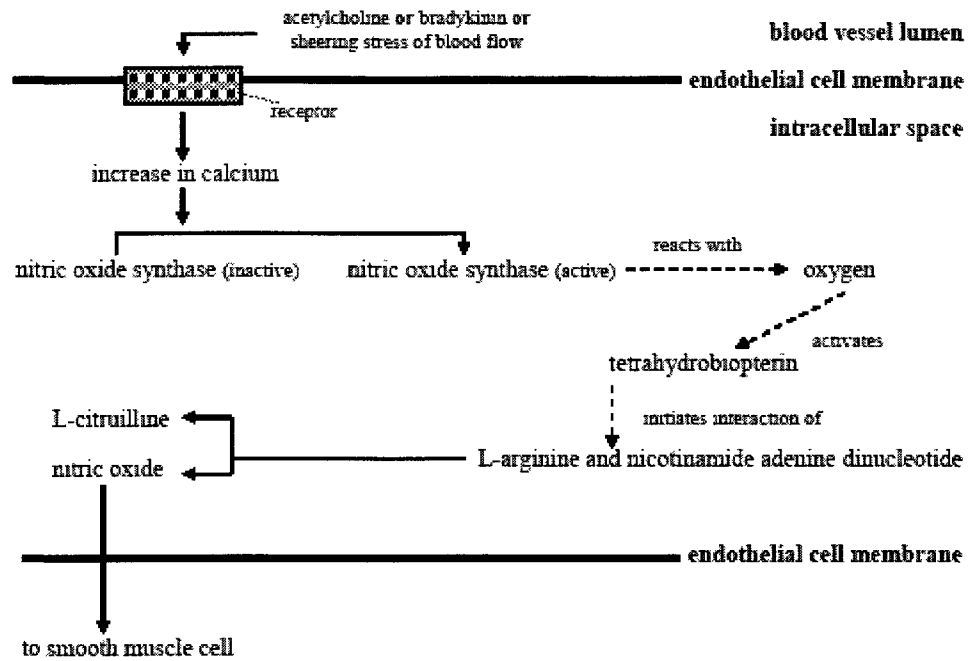

**Figure 10.** Formation of Nitric Oxide in an Endothelial Cell. Acetylcholine, bradykinin or the shearing stress of blood flow act on a receptor located on the endothelial cell membrane and this causes in an increase in calcium intracellularly. The calcium activates nitric oxide synthase which reacts with oxygen and this causes the activation of tetrahydrobiopterin which initiates the interaction of L-arginine and nicotinamide adenine dinucleotide. The interaction initiated by tetrahydrobiopterin produces L-citrulline and nitric oxide. Nitric oxide then travels to the smooth muscle cell to promote vasodilation.

*Note.* This information is from "Restoring Vascular Nitric Oxide Formation by L-arginine Improves the Symptoms of Intermittent Claudication in Patients with Peripheral Arterial Occlusive Disease", by R. Boger, S.Bode-Boger, W. Thiele, A. Creutzig, K. Alexander & J. Frolich, 1998, *Journal of the American College of Cardiology*, 32, 1336-1334; and "Is Type 2 Diabetes Mellitus a Vascular Disease (Atheroscleropathy) with Hyperglycemia a Late Manifestation? The Role of NOS, NO and Redox Stress", by M. Hayden & S. Tyagi, 2002, *Cardiovascular Diabetology*, 2.



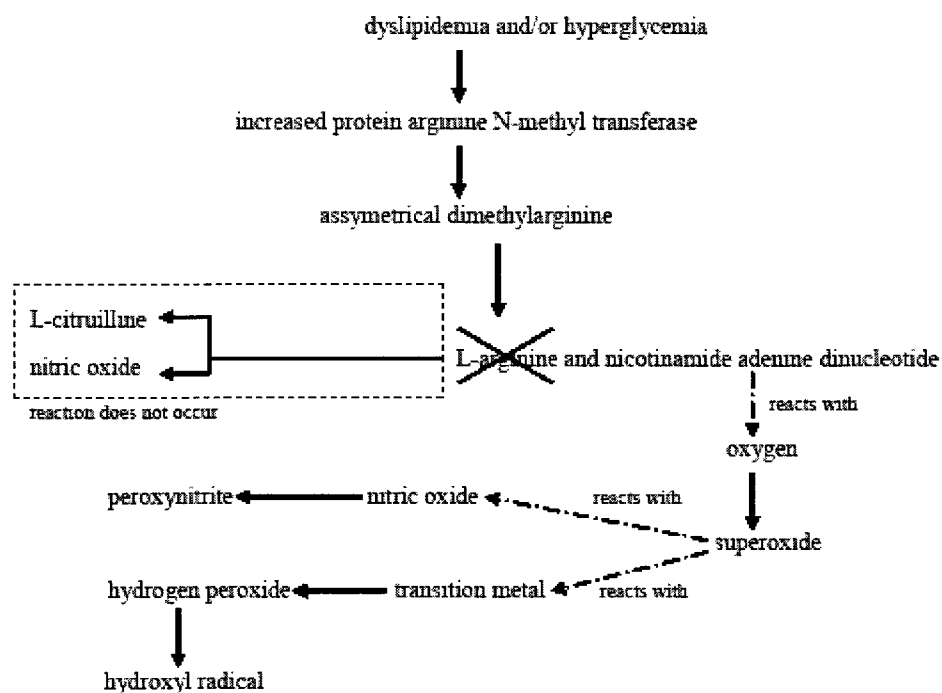

**Figure 11.** Formation of Reactive Oxygen Species instead of Nitric Oxide in the Presence of Dyslipidemia/Hyperglycemia. Dyslipidemia and/or hyperglycemia cause the activity of protein arginine N-methyl transferase to increase and produce asymmetrical dimethylarginine, a L-arginine inhibitor. Decreased L-arginine concentration leads to nicotinamide adenine dinucleotide reacting oxygen (instead of L-arginine) and producing a superoxide. This superoxide can react with a transition metal or nitric oxide (formed in another cell or pathway) to form the superoxides hydroxyl or peroxynitrite respectively.

*Note.* This information is from "Insulin-Resistance, ADMA Levels and Cardiovascular Disease", by D. Nash, 2002, Journal of the American Medical Association, 287, 1451-1452; and "Nitric Oxide, Superoxide and Peroxynitrite: The Good, the Bad and the Ugly", by J. Beckman & W. Koppenol, 1996, American Journal of Physiology, 271, 1424-1437; and "Mitochondrial Formation of Reactive Oxygen Species", by J. Turrens, 2003, The Journal of Physiology, 552, 335-344.

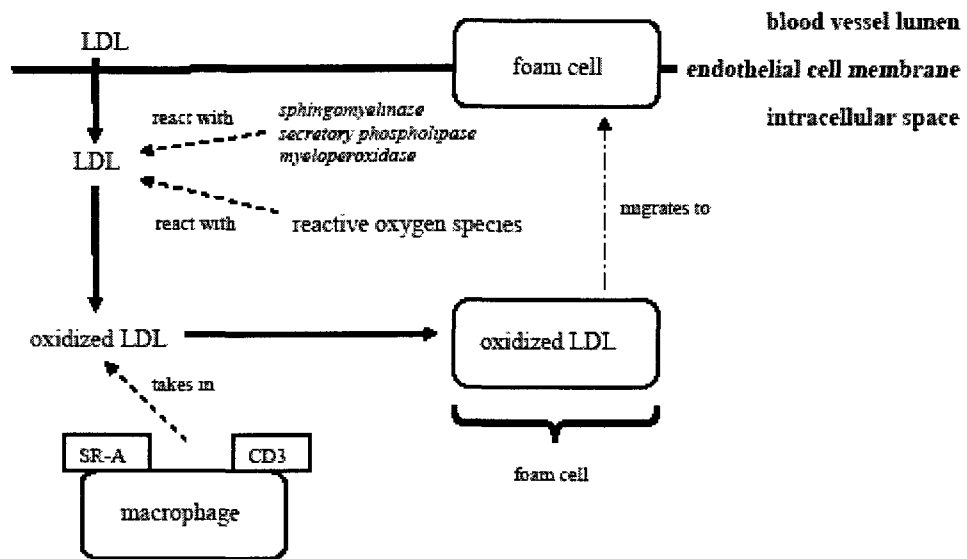

**Figure 12** Foam Cell Formation from Low-Density Lipoproteins in an Endothelial Cell. Low-density lipoprotein (LDL) enters the endothelial cell and reacts with reactive oxygen species and the enzymes sphingomyelinase, secretory phospholipase and myeloperoxidase to form oxidized LDL. The oxidized LDL is taken up by a macrophage through the scavenger receptors SR-A and CD3 to create a foam cell that migrates to the endothelial cell membrane

*Note.* This information is from "Autoimmunity: Busting the Atherosclerotic Plaque", by N. Rose & M. Afanasyeva, 2003, *Nature Medicine*, 9, 641-642; and "Translating Molecular Discoveries into New Therapies for Atherosclerosis", by D. Rader & A. Daugherty, 2008, *Nature*, 451, 904-913.

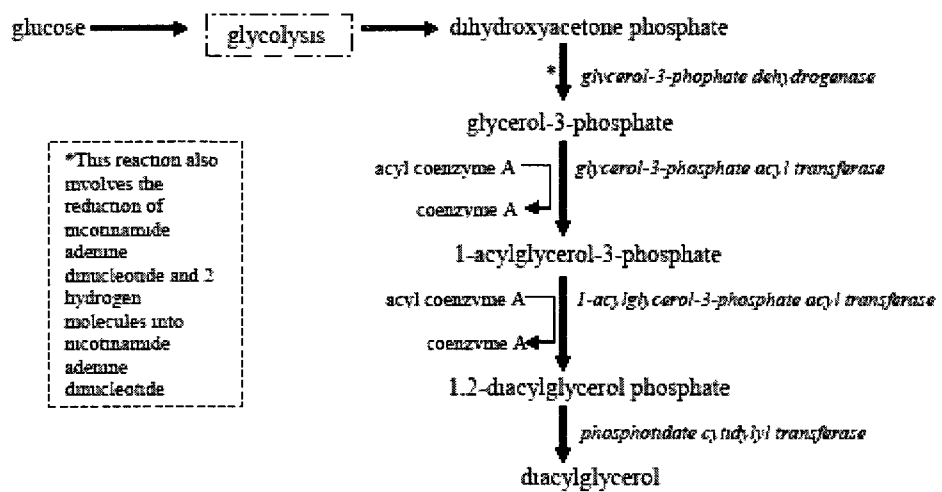

*Figure 13* Conversion of Dihydroxyacetone Phosphate into Diacylglycerol. Glucose enters the cell and through the process of glycolysis is converted into dihydroxyacetone phosphate. Dihydroxyacetone phosphate undergoes reactions catalyzed by enzymes (in *italics*) to produce diacylglycerol. Some of these reactions involve the addition of an acyl group that has been removed from coenzyme A.

---

*Note:* The information is from "Protein Kinase C Activation and the Development of Diabetic Complications", by D. Koya & G. Kang, 1998, *Diabetes* 47, 6, 859-866 and "Involvement of the YnfS/YnfH and PtaX Proteins in Phospholipid Biosynthesis in Both *Bacillus Subtilis* and *Escherichia Coli*", by M. Yoshimura, T. Oshama & N. Ogasawara, 2007, *BMC Microbiology*, 7, 69, and "Exercise Physiology: Theory and Application to Fitness and Performance", by S. Powers & E. Howley, 2009, New York, NY, McGraw-Hill.

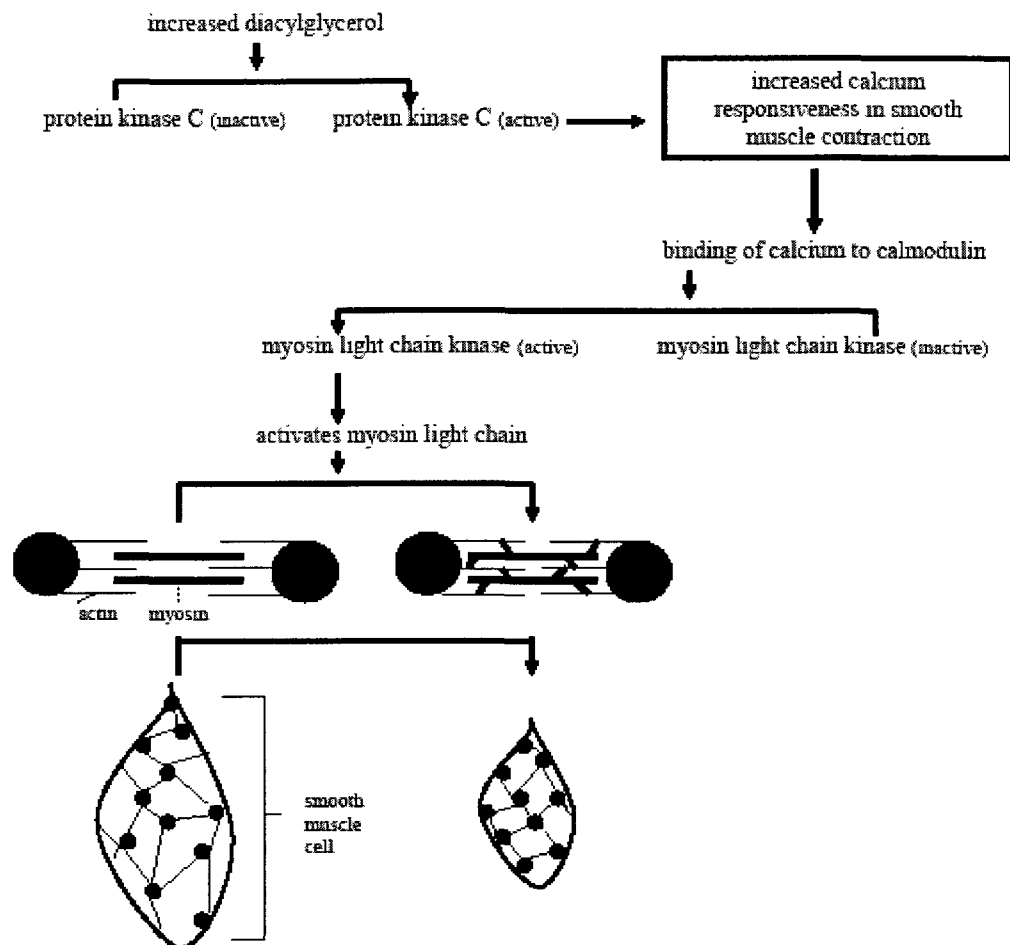

**Figure 14. Protein Kinase C and Smooth Muscle Contraction.** Increased diacylglycerol concentration causes increased activation of protein kinase C which increases the calcium responsiveness in smooth muscle contraction. As calcium binds to calmodulin, it activates myosin light chain kinase which subsequently activates the myosin light chain. This allows myosin to attach to actin and pull adjacent actin filaments closer to each other. This occurs at many locations in the smooth muscle cell causing it to contract.

*Note.* This information is from "Protein Kinase C Activation and the Development of Diabetic Complications", by D. Koya & G. King, 1998, *Diabetes*, 47, 6, 859-866; and "Principles of Human Anatomy (10<sup>th</sup> ed)", by G. Tortora, 2005, Hoboken, IL, John Wiley & Sons, Inc.

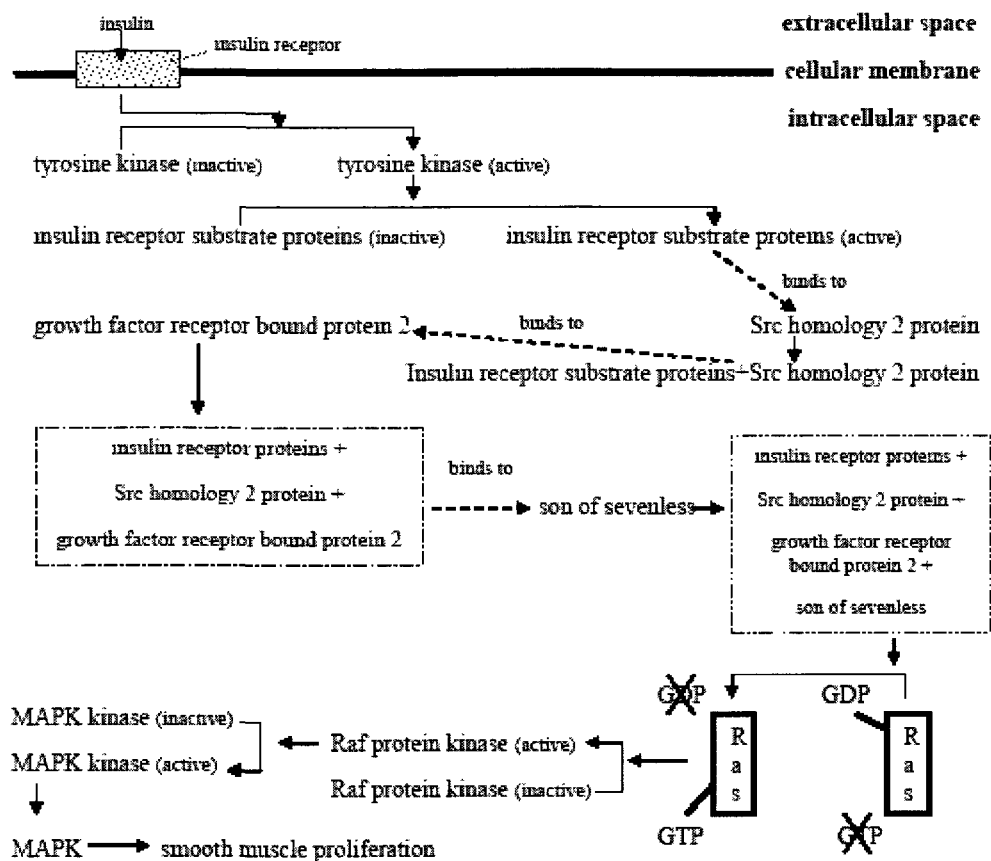

*Figure 15. Smooth Muscle Cell Proliferation Caused by Hyperinsulinemia. Insulin binds to the insulin receptor and activates tyrosine protein kinase which activates insulin receptor substrate proteins which form a complex by binding to Src homology 2 protein, growth factor receptor bound protein 2 and son of sevenless. The complex activates Ras by removing guanosine diphosphate (GDP) and adding guanosine triphosphate (GTP) Ras activates Raf and mitogen-activated protein kinase (MAPK) kinase is subsequently activated to initiate smooth muscle cell proliferation through MAPK.*

*Note. The information is from "Insulin-Induced Mitogen-Activated Protein (MAP) Kinase Phosphatase-1 (MKP-1) Attenuates Insulin-Stimulated MAP Kinase Activity: A Mechanism for Feedback Inhibition of Insulin Signaling", by A. Kusari, J. Byou, D. Bandyopadhyay, K. Kenner & J. Kusari, 1997, Molecular Endocrinology, 11, 10, 1532-1543*



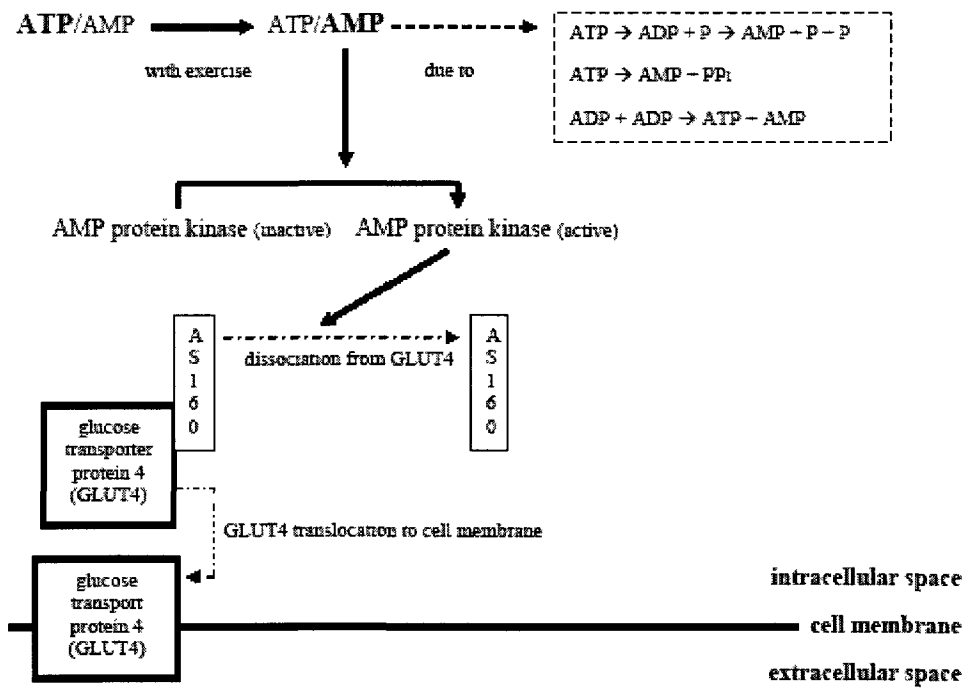

*Figure 17. GLUT4 Translocation caused by AMP Protein Kinase. The ATP (adenosine triphosphate)/AMP (adenosine monophosphate) ratio decreases with exercise due to the use and breakdown of the fuel ATP into ADP (adenosine diphosphate), AMP, PP<sub>i</sub> (pyrophosphate) and P (phosphate). AMP can also increase when ADP molecules accumulate (due to ATP breakdown) and react with each other to form ATP and AMP. The increase in AMP activates AMP protein kinase which is responsible from dissociating the inhibitory protein, AS160, from the glucose transporter (GLUT4) allowing it to translocate to the cell membrane.*

*Note. The information is from "5'AMP-Activated Protein Kinase Activation causes GLUT4 Translocation in Skeletal Muscle", by E. Kruth-Kraczek, M. Hirshman, L. Goodyear, & W. Windler, 1999, Diabetes, 48, 8, 1667-1671; and "Glucose Transport and Glucose Transporters in Muscles and their Metabolic Regulation", by A. Klop & M. Paquet, 1999, Diabetes Care, 13, 3, 288-293. and "Models for Regulation by AMPK/SNF1 of Glucose Uptake in Muscle and Gene Expression in Yeast", by G. Hardie, 2002, Nature Review Molecular Cell Biology, 8, 774-785.*

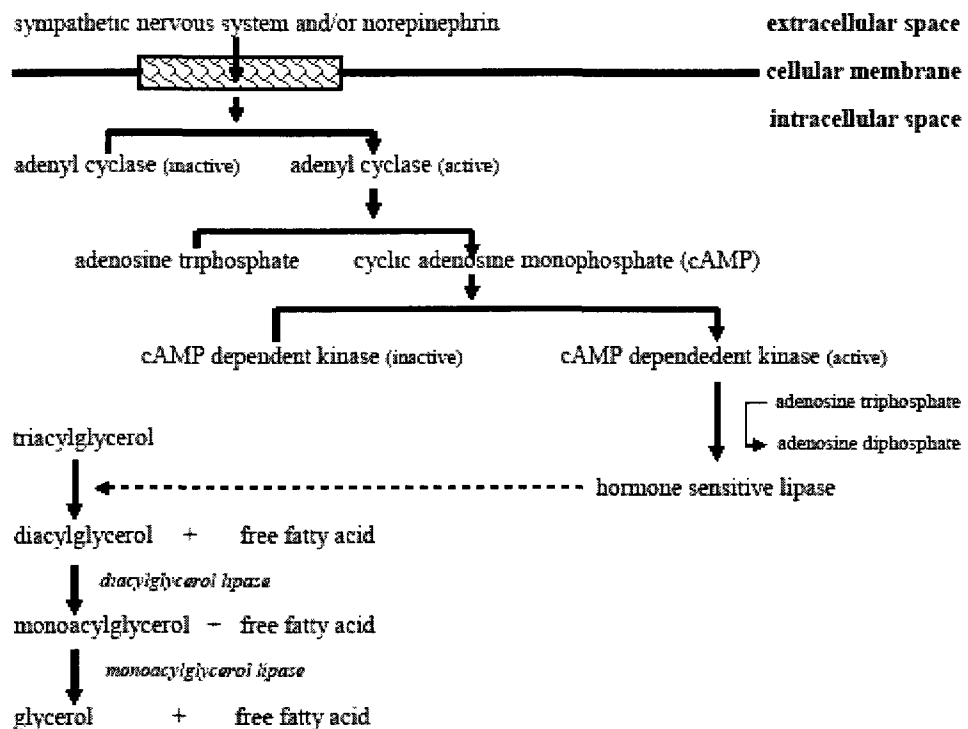

**Figure 18.** Lipolysis: The Breakdown of Triacylglycerol into Glycerol and 3 Fatty Acids. The sympathetic nervous system and/or norepinephrin act on a cellular membrane receptor causing the activation of adenylyl cyclase and thus producing cyclic adenosine monophosphate and activating cyclic adenosine monophosphate dependent kinase. Hormone sensitive lipase is phosphorylated and subsequently activated by cyclic adenosine monophosphate dependent kinase, and acts on triacylglycerol to break it down to diacylglycerol and a free fatty acid. The enzyme (in *italics*) diacylglycerol lipase breaks diacylglycerol into a free fatty acid and monoacylglycerol which is broken down into glycerol and a free fatty acid.

*Note:* This information is from "Exercise Physiology: Theory and Application to Fitness and Performance", by S. Powers & E. Howley, 2009, New York, NY, McGraw-Hill; "Principles of Human Anatomy (10<sup>th</sup> ed)", by G. Tortora, 2005, Hoboken, IL, John Wiley & Sons, Inc.; "Essentials of Exercise Physiology (3<sup>rd</sup> Ed)", by W. McArdle, F. Katch & V. Katch, 2006, Baltimore, MD, Lippincott Williams & Wilkins.



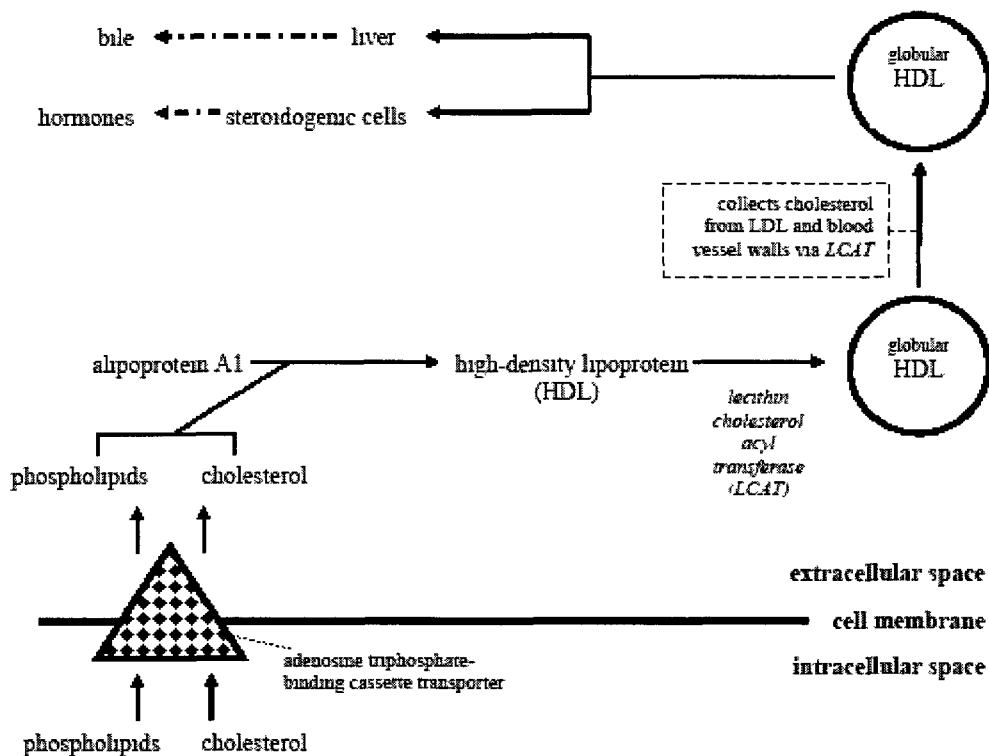

**Figure 19** Creation and Lifespan of High-Density Lipoproteins High-density lipoproteins (HDL) are created when apolipoprotein A1 combines with phospholipids and cholesterol (transported out of hepatic or intestinal cells by the adenosine triphosphate-binding cassette transporter). HDL is acted on by the enzyme (in *uitics*) lecithin cholesterol acyl transferase (LCAT) to create globular HDL which travels through the blood stream collecting cholesterol from LDL (low-density lipoproteins) and blood vessel walls with the aid of LCAT. The globular HDL then travels to the liver or steroidogenic cells to either be excreted as bile or converted into hormones, respectively.

*Note:* This information is from "Cellular Cholesterol Trafficking and Compartmentalization" by E. Ikonen, 2008, *Nature Reviews Molecular Cell Biology*, 9, 125-138.

## **Appendices**

## Appendix A. University of Windsor Review Ethics Board Consent

---



Today's Date June 24 2010  
Principal Investigator Martina Kovacevic  
RI B Number 28376  
Research Project Title RI B# 10-101 Lower extremity isometric training and it's effects on type 2 diabetic claudication  
Clearance Date June 11 2010  
Project End Date August 01 2011  
Milestones  
Renewal Due-2011 08 01(Pending)

This is to inform you that the University of Windsor Research Ethics Board (RI B) which is organized and operated according to the Tri Council Policy Statement and the University of Windsor Guidelines for Research Involving Human Subjects has granted approval to your research project on the date noted above. This approval is valid only until the Project End Date.

A Progress Report or Final Report is due by the date noted above. The RI B may ask for monitoring information at some time during the project's approval period.

During the course of the research no deviations from or changes to the protocol or consent form may be initiated without prior written approval from the RI B. Minor change(s) in ongoing studies will be considered when submitted on the Request to Revise form.

Investigators must also report promptly to the RI B

- a) changes increasing the risk to the participant(s) and or affecting significantly the conduct of the study
- b) all adverse and unexpected experiences or events that are both serious and unexpected
- c) new information that may adversely affect the safety of the subjects or the conduct of the study

Forms for submissions, notifications, or changes are available on the RI B website [www.uwindsor.ca/rcb](http://www.uwindsor.ca/rcb). If your data is going to be used for another project, it is necessary to submit another application to the RI B. We wish you every success in your research.

A handwritten signature in black ink, appearing to read 'Pierre Boulos'.

Pierre Boulos, Ph.D.  
Chair, Research Ethics Board

This is an official document. Please retain the original in your files.  
cb

## Appendix B. Windsor Regional Hospital Research Ethics Board Consent



### Research Ethics Board

#### Delegated Review

**Review Date:** October 14, 2010

**Project Title:** Lower extremity isometric training and its effect on Type 2 Diabetic Claudication

**Principal Investigator:** Martina Kovacevic, University of Windsor

**REB File Reference:** 10-201-21

#### Items Reviewed:

Ethics Submission Form dated October 6, 2010  
Appendix C – Poster and Flyer  
University of Windsor Ethics Approval Letter dated September 22, 2010.  
Letter to Research Ethics Board – undated (received October 6, 2010).

**Solicitation for participants for your research from Windsor Regional Hospital's Patients in the Cardiac Wellness Program .**

**Approval has been granted for placement of Research Participant Recruitment Poster. Flyers may be left in waiting area for any patient who chooses to take one. Eligible patients are not to be identified by being distributed flyers as this would constitute a breach in patient privacy and confidentiality.**

This Research Ethics Board is constituted and operated in accordance with the Tri-Council Policy Statement for Ethical Conduct of Research Involving Humans (TCPS), Canadian Food & Drug Regulations, Division 5 (Clinical Trials), ICH Good Clinical Practice Guidelines E6, Personal Health Information Protection Act, 2004 (PHIPA), U.S. Code of Federal Regulations Title 21 & 45.

Only Research Ethics Board members who are independent of the investigator(s) conducting the study participated in decisions relating to this research.

#### **COPY**

---

Wallace Liang, MD., LLB., MHsc.  
Chair, Research Ethics Board  
Windsor Regional Hospital

Appendix C. Poster Advertisement



**Leg Pain /Cramping and Type 2 Diabetes Study**

Be part of an *important* leg pain and cramping study:

- Are you over the age of 18?
- Do you have type 2 diabetes?
- Have you been diagnosed with peripheral arterial disease?
- Do you feel pain or cramping in your legs after walking short distances?

If you answered *YES*, you may be eligible to participate in a research study

Please contact Martina Kovacevic at (519) 253-3000 ext 4979  
 kovacevm@uwindsor.ca

\*study cleared by the University of Windsor Research Ethics Board

5	5	5	5	5	5	5	5	k	k	k	k	k	k	k	k
1	1	1	1	1	1	1	1	o	o	o	o	o	o	o	o
9	9	9	9	9	9	9	9	v	v	v	v	v	v	v	v
2	2	2	2	2	2	2	2	a	a	a	a	a	a	a	a
5	5	5	5	5	5	5	5	e	e	e	e	e	e	e	e
3	3	3	3	3	3	3	3	v	v	v	v	v	v	v	v
3	3	3	3	3	3	3	3	m	m	m	m	m	m	m	m
0	0	0	0	0	0	0	0	@	@	@	@	@	@	@	@
0	0	0	0	0	0	0	0	u	u	u	u	u	u	u	u
0	0	0	0	0	0	0	0	w	w	w	w	w	w	w	w
e	e	e	e	e	e	e	e	i	i	i	i	i	i	i	i
x	x	x	x	x	x	x	x	n	n	n	n	n	n	n	n
t	t	t	t	t	t	t	t	d	d	d	d	d	d	d	d
4	4	4	4	4	4	4	4	s	s	s	s	s	s	s	s
9	9	9	9	9	9	9	9	o	o	o	o	o	o	o	o
7	7	7	7	7	7	7	7	r	r	r	r	r	r	r	r
9	9	9	9	9	9	9	9	.	.	.	.	.	.	.	.
								c	c	c	c	c	c	c	c
								a	a	a	a	a	a	a	a

## Appendix D. Letter of Information for Consent to Participate in Research



### LETTER OF INFORMATION FOR CONSENT TO PARTICIPATE IN RESEARCH

Title of Study: **Lower extremity isometric training and its effect on type 2 diabetic claudication**

You are asked to participate in a research study conducted by **Martina Kovacevic and Dr. Cheri McGowan** from the **Department of Kinesiology** at the University of Windsor as a requirement of Martina's **master's level thesis**.

If you have any questions or concerns about the research, please feel to contact **Martina Kovacevic at 519-253-3000 ext 4979; or Dr. Cheri McGowan at 519-253-3000 ext 2451**. For questions or concerns during non-working hours, please contact Dr. Cheri McGowan at 734-904-8488.

#### PURPOSE OF THE STUDY

The purposes of this study are to determine if isometric leg (i.e., squeezing your calf muscles without moving them) training will improve lower leg blood flow, delay the progression of peripheral arterial disease and reduce the leg cramping that happens with walking in people with type 2 diabetes.

#### PROCEDURES

If you volunteer to participate in this study, you will be asked to:

##### INITIAL VISITS:

After expressing interest in this study, you will be asked to come to the Physical Activity and Cardiovascular Research (PACR) Lab (Room #240, Kinesiology Building, University of Windsor, ON, Canada) to sign the necessary forms, fill out a medical questionnaire and receive the physical activity readiness medical examination to be filled out and signed by your doctor. At this time, you will also arrange a date to visit the PACR Lab again to familiarize yourself with the equipment and lab, and find out whether you are in the training (exercise) or non-training control (blood pressure monitoring) group.

##### TESTING DAY (approx. 1 hour):

You will be asked not to drink or eat alcohol or caffeine for 12 hours before the visit and not to smoke for 30 minutes before the visit. You will need to come to the PACR Lab dressed in a short-sleeved shirt, shorts and comfortable walking shoes. You will be asked to rest for ten minutes, then blood pressure measurements will be taken twice in each arm and four times in each leg. Following this, ultrasound pictures of the popliteal arteries (large arteries in the back of the knee) will be taken on both legs using a wand-like instrument covered in gel. You will then be asked to walk on a treadmill at 2 mph with an increasing incline for as long as you feel comfortable. Ultrasounds pictures of your popliteal arteries will be taken again once you complete the walk.

This testing day will be repeated at the end of the 8 week training period whether you are in the training or non-training group.

### **TRAINING DAYS FOR TRAINING GROUP (approx. 45 minutes):**

Approximately 1 week following the testing day, you will be asked to visit the PACR Lab 3 times per week for 8 consecutive weeks for isometric leg training. Prior to the training session a pre-exercise and post-exercise finger-prick test to measure blood glucose to make sure that it is not too low (if it is you will be offered a snack). The training will consist of performing exercises using a machine resembling a desk, where you sit in a chair at the desk and press up on the desk top from underneath with your knees by trying to point your toes. The exercises will last for 2 minutes followed by a 2-minute rest period, and this will be done 4 times. The training day will begin with 10 minutes of rest and blood pressure measurements in the arms and legs. The exercises will be performed next and blood pressure measurements in one arm will be taken every 2 minutes. Following the exercise, blood pressure measurements will be taken in the arms and legs again.

### **TRAINING DAYS FOR CONTROL GROUP (approx. 30 minutes):**

Approximately 1 week following the testing day, you will be asked to visit the PACR Lab 3 times per week for 8 consecutive weeks for blood pressure monitoring. You will need to be dressed in a short-sleeved or sleeve-less shirt and after resting for ten minutes, blood pressure measurements will be taken twice in each arm and four times in each leg.

## **POTENTIAL RISKS AND DISCOMFORTS**

You may experience tendonitis in the tendons of the legs with isometric training, however, this risk is minimal if the exercise is properly performed. The blood pressure and blood flow measurement procedures are non-invasive, but you may experience numbness or tingling with the cuffs while we are taking our measurements. You may also experience some tenderness in the areas of the finger-prick test.

The intermittent claudication test (treadmill walking) is a safe test when used properly, and when participants have been appropriately screened (which you will be once you have filled out the medical questionnaire and your physician has completed physical activity readiness medical examination). Occasionally, for safety reasons, we may have to stop the test. In cases of emergency, you will be given first line treatment, as appropriate. Our laboratory's emergency action plan (EAP) is posted in the laboratory.

Please contact one of the study investigators if you feel any adverse effects from completing any portion of the study, and/or if you have any questions or concerns. Study investigators will reinforce proper training technique throughout the study. If you experience any adverse effects during any testing procedure, first line response will be provided.

## **POTENTIAL BENEFITS TO SUBJECTS AND/OR TO SOCIETY**

You will benefit from this study by having your blood pressure measured, recorded and tracked for a ten week period. You will be given this data upon request for your medical history. This study will also provide you with new and different exercises to help control symptoms of claudication.

The scientific community and society will be able to use this study for information on non-drug-related ways to control peripheral arterial disease and blood pressure because medications are usually expensive and give the user unwanted side effects.

## **COMPENSATION FOR PARTICIPATION**

You will receive a University of Windsor Kinesiology Research t-shirt. You will also be reimbursed for parking fees and the potential fee for completion of the physical activity readiness medical examination and medical release by their primary care physician. If you were assigned to the non-training control group will be given the chance to take part in the training exercises after the study is done.

## CONFIDENTIALITY

Any information that is obtained in connection with this study and that can be identified with you will remain confidential and will be disclosed only with your permission

***You will be assigned an identification number. Your name will not be used in any information collection, publication or presentation.***

All paper and electronic data will be stored in a locked laboratory of the principal investigator. Information stored on computer will be password-accessible only, and will be available only to the study investigators. Upon publication of the study, all paper records will be shredded.

## PARTICIPATION AND WITHDRAWAL

You can choose whether to be in this study or not. If you volunteer to be in this study, you may withdraw at any time without consequences of any kind. You may also refuse to answer any questions you don't want to answer and still remain in the study. The investigator may withdraw you from this research if circumstances arise which warrant doing so.

## FEEDBACK OF THE RESULTS OF THIS STUDY TO THE SUBJECTS

***Research findings will be available to participants by mail or email. Results will also be posted on the University of Windsor's Research Ethics Board (REB) website in August 2011.***

Web address \_\_\_\_\_

Date when results are available \_\_\_\_\_

## SUBSEQUENT USE OF DATA

This data will not be used in subsequent studies.

## RIGHTS OF RESEARCH SUBJECTS

You may withdraw your consent at any time and discontinue participation without penalty. If you have questions regarding your rights as a research subject, contact Research Ethics Coordinator, University of Windsor, Windsor, Ontario N9B 3P4, Telephone 519-253-3000, ext 3948, e-mail [ethics@uwindsor.ca](mailto:ethics@uwindsor.ca)

## SIGNATURE OF INVESTIGATOR

These are the terms under which I will conduct research

\_\_\_\_\_  
Signature of Investigator

\_\_\_\_\_  
Date



## Appendix E. Consent to Participate in Research



### CONSENT TO PARTICIPATE IN RESEARCH

Title of Study: **Lower extremity isometric training and its effect on type 2 diabetic claudication**

You are asked to participate in a research study conducted by **Martina Kovacevic and Dr. Cheri McGowan** from the **Department of Kinesiology** at the University of Windsor as a requirement of Martina's **master's level thesis**.

If you have any questions or concerns about the research, please feel to contact **Martina Kovacevic at 519-253-3000 ext 4979; or Dr. Cheri McGowan at 519-253-3000 ext 2451**. For questions or concerns during non-working hours, please contact Dr. Cheri McGowan at 734-904-8488.

#### PURPOSE OF THE STUDY

The purposes of this study are to determine if isometric leg (i.e., squeezing your calf muscles without moving them) training will improve lower leg blood flow, delay the progression of peripheral arterial disease and reduce the leg cramping that happens with walking in people with type 2 diabetes.

#### PROCEDURES

If you volunteer to participate in this study, you will be asked to:

##### INITIAL VISITS:

After expressing interest in this study, you will be asked to come to the Physical Activity and Cardiovascular Research (PACR) Lab (Room #240, Kinesiology Building, University of Windsor, ON, Canada) to sign the *necessary forms*, fill out a *medical questionnaire* and receive the *physical activity readiness medical examination* to be filled out and signed by your doctor. At this time, you will also arrange a date to visit the PACR Lab again to familiarize yourself with the equipment and lab, and find out whether you are in the training (exercise) or non-training control (blood pressure monitoring) group.

##### TESTING DAY (approx. 1 hour):

You will be asked not to drink or eat alcohol or caffeine for 12 hours before the visit and not to smoke for 30 minutes before the visit. You will need to come to the PACR Lab dressed in a short-sleeved shirt, shorts and comfortable walking shoes. You will be asked to rest for ten minutes, then blood pressure measurements will be taken twice in each arm and four times in each leg. Following this, ultrasound pictures of the popliteal arteries (large arteries in the back of the knee) will be taken on both legs using a wand-like instrument covered in gel. You will then be asked to walk on a treadmill at 2 mph with an increasing incline for as long as you feel comfortable. Ultrasounds pictures of your popliteal arteries will be taken again once you complete the walk.

This testing day will be repeated at the end of the 8 week training period whether you are in the training or non-training group.

##### TRAINING DAYS FOR TRAINING GROUP (approx. 45 minutes):

Approximately 1 week following the testing day, you will be asked to visit the PACR Lab 3 times per week for 8 consecutive weeks for isometric leg training. Prior to the training session a pre-exercise and post-exercise finger-prick test to measure blood glucose to make sure that it is not too low (if it is you will be offered a snack). The training will consist of performing exercises using a machine resembling a desk, where you sit in a chair at the desk and press up on the desk top from underneath with your knees by trying to point your toes. The exercises will last for 2 minutes followed by a 2-minute rest period, and this will be done 4 times. The training day will begin with 10 minutes of rest and blood pressure measurements in the arms and legs. The exercises will be performed next and blood pressure measurements in one arm will be taken every 2 minutes. Following the exercise, blood pressure measurements will be taken in the arms and legs again.

### **TRAINING DAYS FOR CONTROL GROUP (approx. 30 minutes):**

Approximately 1 week following the testing day, you will be asked to visit the PACR Lab 3 times per week for 8 consecutive weeks for blood pressure monitoring. You will need to be dressed in a short-sleeved or sleeve-less shirt and after resting for ten minutes, blood pressure measurements will be taken twice in each arm and four times in each leg.

### **POTENTIAL RISKS AND DISCOMFORTS**

You may experience tendonitis in the tendons of the legs with isometric training, however, this risk is minimal if the exercise is properly performed. The blood pressure and blood flow measurement procedures are non-invasive, but you may experience numbness or tingling with the cuffs while we are taking our measurements. You may also experience some tenderness in the areas of the finger-prick test.

The intermittent claudication test (treadmill walking) is a safe test when used properly, and when participants have been appropriately screened (which you will be once you have filled out the medical questionnaire and your physician has completed physical activity readiness medical examination). Occasionally, for safety reasons, we may have to stop the test. In cases of emergency, you will be given first line treatment, as appropriate. Our laboratory's emergency action plan (EAP) is posted in the laboratory.

Please contact one of the study investigators if you feel any adverse effects from completing any portion of the study, and/or if you have any questions or concerns. Study investigators will reinforce proper training technique throughout the study. If you experience any adverse effects during any testing procedure, first line response will be provided.

### **POTENTIAL BENEFITS TO SUBJECTS AND/OR TO SOCIETY**

You will benefit from this study by having your blood pressure measured, recorded and tracked for a ten week period. You will be given this data upon request for your medical history. This study will also provide you with new and different exercises to help control symptoms of claudication.

The scientific community and society will be able to use this study for information on non-drug-related ways to control peripheral arterial disease and blood pressure because medications are usually expensive and give the user unwanted side effects.

### **COMPENSATION FOR PARTICIPATION**

You will receive a University of Windsor Kinesiology Research t-shirt. You will also be reimbursed for parking fees and the potential fee for completion of the physical activity readiness medical examination and medical release by their primary care physician. If you were assigned to the non-training control group will be given the chance to take part in the training exercises after the study is done.

### **CONFIDENTIALITY**

Any information that is obtained in connection with this study and that can be identified with you will remain confidential and will be disclosed only with your permission.

***You will be assigned an identification number. Your name will not be used in any information collection, publication or presentation.***

All paper and electronic data will be stored in a locked laboratory of the principal investigator. Information stored on computer will be password-accessible only, and will be available only to the study investigators. Upon publication of the study, all paper records will be shredded.

## PARTICIPATION AND WITHDRAWAL

You can choose whether to be in this study or not. If you volunteer to be in this study, you may withdraw at any time without consequences of any kind. You may also refuse to answer any questions you don't want to answer and still remain in the study. The investigator may withdraw you from this research if circumstances arise which warrant doing so.

## FEEDBACK OF THE RESULTS OF THIS STUDY TO THE SUBJECTS

***Research findings will be available to participants by mail or email. Results will also be posted on the University of Windsor's Research Ethics Board (REB) website in August 2011.***

Web address: \_\_\_\_\_

Date when results are available: \_\_\_\_\_

## SUBSEQUENT USE OF DATA

This data will not be used in subsequent studies

## RIGHTS OF RESEARCH SUBJECTS

You may withdraw your consent at any time and discontinue participation without penalty. If you have questions regarding your rights as a research subject, contact: Research Ethics Coordinator, University of Windsor, Windsor, Ontario, N9B 3P4; Telephone: 519-253-3000, ext. 3948; e-mail: [ethics@uwindsor.ca](mailto:ethics@uwindsor.ca)

## SIGNATURE OF RESEARCH SUBJECT/LEGAL REPRESENTATIVE

I understand the information provided for the study **Lower extremity isometric training and its effect on type 2 diabetic claudication** as described herein. My questions have been answered to my satisfaction, and I agree to participate in this study. I have been given a copy of this form.

\_\_\_\_\_  
Name of Subject

\_\_\_\_\_  
Signature of Subject

\_\_\_\_\_  
Date

## SIGNATURE OF INVESTIGATOR

These are the terms under which I will conduct research.

\_\_\_\_\_  
Signature of Investigator

\_\_\_\_\_  
Date

## Appendix F. Medical Questionnaire

### Medical Questionnaire

Last Name \_\_\_\_\_ First Name \_\_\_\_\_

Address \_\_\_\_\_ City \_\_\_\_\_

Province \_\_\_\_\_

Height: \_\_\_\_\_ Weight \_\_\_\_\_ Sex \_\_\_\_\_

Date of Birth \_\_\_\_\_ Home Phone # ( \_\_\_\_\_ ) \_\_\_\_\_ Postal Code \_\_\_\_\_  
Month Year

FOR EMERGENCY NOTIFY: Name \_\_\_\_\_ Relationship \_\_\_\_\_

Address \_\_\_\_\_ Phone ( \_\_\_\_\_ ) \_\_\_\_\_

Family Doctor's Name \_\_\_\_\_ Date of Last Physical \_\_\_\_\_

Please Check Yes or No:

Yes No

1. Have you been diagnosed with type 2 diabetes? .....

2. Have you been diagnosed or are under the suspicion of peripheral arterial disease? .....

3. Have you ever had surgery? .....

If yes, please specify? \_\_\_\_\_

4. Are you presently taking any medications or pills (including aspirin and other over-the-counter medication)? .....

If yes, please specify? \_\_\_\_\_

5. Do you have any allergies (medicine, food, bees or other stinging insects)? .....

If yes, please specify? \_\_\_\_\_

6. Have you ever felt dizzy or passed out during or after exercise? .....

7. Have you ever had chest pain during or after exercise? .....

8. Do you have high blood pressure (hypertension) or low blood pressure (hypotension)? .....

9. Have you ever been told that you have a heart problem? .....

10. Do you have any skin problems (itching, rashes, acne)? .....

11. If you experience a blow to a muscle, do you bruise easily? .....

12. Do you have Asthma or any other breathing problems? .....

If yes, please specify? \_\_\_\_\_

13. Do you have any type of cardiovascular disease? .....

If yes, please specify? \_\_\_\_\_

14. Do you smoke? .....

# Appendix G. Physical Activity Readiness Medical Examination (PARmed-X)

Version 1.0  
 Date: 11/11/11  
 Rev: 0.0

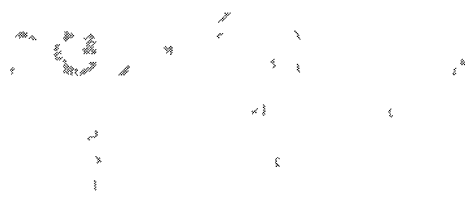

Regular physical activity is fun and healthy and increasing your level of activity can start to reduce your risk of heart disease every day. Being more active is safe for most people. The PARmed-X by itself provides a adequate screening for the majority of people. However, some individuals may require a medical evaluation and specific advice regarding participation in one or more physical activity programs. The PARmed-X

Follow the participant evaluation with a physician a physical activity plan should be devised in consultation with a physical activity professional (CSEP Professional Fitness & Lifestyle Consultant or CSEP Exercise Therapist™). To assist in this the following instructions are provided:

**PAGE 1** Section A is a Current Checklist to be completed by the participant. B-E are the examination by the physician. The bottom section is to be completed by the examining physician.

**PAGES 2 & 3** A checklist of medical conditions requiring special consideration and management.

**PAGE 4** Physical Activity & Lifestyle Advice for people who do not require special instructions or prescribed exercise. Physical Activity Readiness Conveyance/Referral Form is optional part of the physician conveyance clearances for physical activity participation or to make a referral to a medically supervised exercise program.

### This section to be completed by the participant

<p><b>PERSONAL INFORMATION</b></p> <p>NAME _____</p> <p>ADDRESS _____</p> <p>TELEPHONE _____</p> <p>PHYSICIAN _____</p> <p>MEDICAL _____</p>	<p><b>PARmed-X</b> Please read all the PARmed-X questions to which you answered "YES"</p> <p><input type="checkbox"/> 1. Heart condition</p> <p><input type="checkbox"/> 2. Chest pain during activity</p> <p><input type="checkbox"/> 3. Chest pain at rest</p> <p><input type="checkbox"/> 4. Loss of balance/dizziness</p> <p><input type="checkbox"/> 5. Breathing problem</p> <p><input type="checkbox"/> 6. Blood pressure or heart drugs</p> <p><input type="checkbox"/> 7. Other reason</p>
----------------------------------------------------------------------------------------------------------------------------------------------	-----------------------------------------------------------------------------------------------------------------------------------------------------------------------------------------------------------------------------------------------------------------------------------------------------------------------------------------------------------------------------------------------------------------------------------------------------------------------------------------------------

<p><b>RISK FACTORS FOR CARDIOVASCULAR DISEASE</b>  <i>Check all that apply</i></p> <p><input type="checkbox"/> Less than 30 minutes of moderate physical activity most days of the week</p> <p><input type="checkbox"/> Currently smoker (at least once smoking 1 or more times per week)</p> <p><input type="checkbox"/> High blood pressure reported by physician on three repeated measurements</p> <p><input type="checkbox"/> High cholesterol level reported by physician</p> <p><input type="checkbox"/> Excessive accumulation of fat around waist</p> <p><input type="checkbox"/> Family history of heart disease</p> <p><i>Please note: Many of these risk factors are modifiable. Please refer to page 4 and discuss with your physician.</i></p>	<p><b>PHYSICAL ACTIVITY INTENTIONS</b></p> <p>What physical activity do you intend to do?</p> <p>_____</p> <p>_____</p>
------------------------------------------------------------------------------------------------------------------------------------------------------------------------------------------------------------------------------------------------------------------------------------------------------------------------------------------------------------------------------------------------------------------------------------------------------------------------------------------------------------------------------------------------------------------------------------------------------------------------------------------------------------------------------------------------------------------------------------------------------------------	-------------------------------------------------------------------------------------------------------------------------

### This section to be completed by the examining physician

<p><b>Physical Exam</b></p> <p>Ht _____ Wt _____   BP (I) _____</p> <p>_____   BP (II) _____</p> <p><b>Conditions limiting physical activity</b></p> <p><input type="checkbox"/> Cardiovascular    <input type="checkbox"/> Respiratory    <input type="checkbox"/> Other</p> <p><input type="checkbox"/> Musculoskeletal    <input type="checkbox"/> Abdominal</p> <p><b>Tests required</b></p> <p><input type="checkbox"/> ECG    <input type="checkbox"/> Exercise Test    <input type="checkbox"/> X-Ray</p> <p><input type="checkbox"/> Blood    <input type="checkbox"/> Urinalysis    <input type="checkbox"/> Other</p>	<p><b>Physical Activity Readiness Conveyance/Referral</b></p> <p>Based upon a current review of health and fitness status, I recommend:</p> <p><input type="checkbox"/> <b>Approved</b></p> <p><input type="checkbox"/> <b>Not approved</b></p> <p><input type="checkbox"/> No physical activity</p> <p><input type="checkbox"/> Only a medically supervised exercise program until further medical clearance</p> <p><input type="checkbox"/> Progressive physical activity</p> <p><input type="checkbox"/> with avoidance of _____</p> <p><input type="checkbox"/> with restriction of _____</p> <p><input type="checkbox"/> under the supervision of a CSEP Professional Fitness &amp; Lifestyle Consultant or CSEP Exercise Therapist™</p> <p><input type="checkbox"/> Unrestricted physical activity—start slowly and build up gradually</p>
---------------------------------------------------------------------------------------------------------------------------------------------------------------------------------------------------------------------------------------------------------------------------------------------------------------------------------------------------------------------------------------------------------------------------------------------------------------------------------------------------------------------------------------------------------------------------------------------------------------------------------	--------------------------------------------------------------------------------------------------------------------------------------------------------------------------------------------------------------------------------------------------------------------------------------------------------------------------------------------------------------------------------------------------------------------------------------------------------------------------------------------------------------------------------------------------------------------------------------------------------------------------------------------------------------------------------------------------------------------------------------------------------------------------------------------------------------------------------------------------



Canadian Society for Exercise Physiology

Approved by



Health Canada / Santé Canada



	Special Prescriptive Conditions	ADVICE
Lung	<ul style="list-style-type: none"> <li><input type="checkbox"/> chronic respiratory disorders                             <ul style="list-style-type: none"> <li><input type="checkbox"/> obstructive lung disease</li> <li><input type="checkbox"/> asthma</li> </ul> </li> <li><input type="checkbox"/> exercise-induced bronchospasm</li> </ul>	<p>adequate relaxation and breathing exercises</p> <p>Breath control during endurance exercises to tolerate air; avoid polluted air</p> <p>avoid hyperventilation during exercise; avoid extremely cold conditions; warm-up adequately; utilize appropriate medication.</p>
Musculoskeletal	<ul style="list-style-type: none"> <li><input type="checkbox"/> low back variations (pathological, functional)</li> <li><input type="checkbox"/> arthritis—acute, osteoarthritis, rheumatoid, psoriatic</li> <li><input type="checkbox"/> arthritis—osteoarthritis</li> <li><input type="checkbox"/> arthritis—osteoarthritis (osteoarthritis and acute conditions)</li> <li><input type="checkbox"/> other, acute</li> <li><input type="checkbox"/> hernia</li> <li><input type="checkbox"/> osteoporosis or low bone density</li> </ul>	<p>avoid to maximize exercise that precipitates or exacerbates (e.g., forced extreme flexion, extension, and wheelbarrow, curled posture, repeated back exercises)</p> <p>warm-up; post-exercise heat of rest; splinting and gentle movement</p> <p>to aggressive management of acute conditions therapy</p> <p>maintenance of mobility and strength; non-weight-bearing activities to maximize joint health (e.g., cycling, aquatic activity, etc.)</p> <p>highly varied and individualized</p> <p>for those training and conditioning: strengthen abdominal muscles</p> <p>avoid exercise with high risk for fracture such as push-ups, outsteps, vertical jump and trunk forward flexion; engage in low-impact weight-bearing activities and resistance training</p>
CNS	<ul style="list-style-type: none"> <li><input type="checkbox"/> cognitive disorder not completely controlled by medication</li> <li><input type="checkbox"/> recent concussion</li> </ul>	<p>for those of a high risk for falls: low-impact environments and/or exercising alone (e.g., swimming, motorcycle riding, etc.)</p> <p>thorough examination of history of two conditions; review for discontinuation of contact sport if three (3) or less; depending on duration of amnesia/prose, retrograde amnesia, persistent headaches, and other object of evidence of cerebral damage</p>
Blood	<ul style="list-style-type: none"> <li><input type="checkbox"/> anemia—mild or 10-30% Hb</li> <li><input type="checkbox"/> electrolyte disturbances</li> </ul>	<p>control preferred; exercise as tolerated</p>
Medications	<ul style="list-style-type: none"> <li><input type="checkbox"/> anti-anginal</li> <li><input type="checkbox"/> anti-hypertensive</li> <li><input type="checkbox"/> beta-blockers</li> <li><input type="checkbox"/> diuretics</li> <li><input type="checkbox"/> others</li> <li><input type="checkbox"/> anti-arrhythmic</li> <li><input type="checkbox"/> anticholinergic</li> <li><input type="checkbox"/> digitalis preparations</li> <li><input type="checkbox"/> ganglionic blockers</li> </ul>	<p>NOTE: consider underlying condition. Potential for: exertional syncope, electrolyte imbalance, bradycardia, dysrhythmias, impaired coordination and reaction time, heat intolerance. May alter resting and exercise ECGs and exercise test performance.</p>
Other	<ul style="list-style-type: none"> <li><input type="checkbox"/> post-exercise syndrome</li> <li><input type="checkbox"/> heat intolerance</li> <li><input type="checkbox"/> temporary muscle disease</li> <li><input type="checkbox"/> cancer</li> </ul>	<p>moderate program</p> <p>prolong cool-down with light activities; avoid exercise in extreme heat</p> <p>postpone until recovered</p> <p>if potential for arrhythmias, led by cycle ergometry, consider non-weight bearing exercises; exercise at lower end of prescriptive range (40-60% of heart rate reserve), depending on condition and recent treatment (radiation, chemotherapy); monitor hemoglobin and lymphocyte counts; add dynamic/kinetic exercise to strengthen muscles; using machines rather than weights.</p>

\*Refer to special publications for elaboration as required.

The following companion forms are available online: <http://www.csap.ca/forms.asp>

The **Physical Activity Readiness Questionnaire (PAR-Q)** - a questionnaire for people aged 15-69 to complete before becoming much more physically active.

The **Physical Activity Readiness Medical Examination for Pregnancy (PARmed-X for PREGNANCY)** - to be used by physicians with pregnant patients who wish to become more physically active.

For more information, please contact the:

Canadian Society for Exercise Physiology  
222 - 185 Somerset St. West  
Ottawa, ON K1P 6L2  
Tel: 1-877-659-3755 • FAX: (613) 834-3565 • Online: [www.csap.ca](http://www.csap.ca)

### Note to physical activity professionals...

It is a prudent practice to retain the completed Physical Activity Readiness Conveyance/Referral Form as the participant's file.



© Canadian Society for Exercise Physiology

Supported by:



Health  
Canada

Santé  
Canada

continued on page 4



End an e  
 f exist by  
 7 days a week  
 Gentle walking, bending  
 and stretching activities, by  
 keep your muscles relaxed  
 and joints mobile  
 Strength  
 4 one week  
 When a patient has stance  
 to strengthen muscles and  
 bones e.g. walking posture

**PARmed-X Physical Activity Readiness Conveyance/Referral Form**

- Based upon routine review of health status
- No physical activity
- Only a medically prescribed exercise program until further medical clearance
- Progressive physical activity
  - with supervision of
  - with independent
  - with a certified supervisory exercise professional fitness & lifestyle consultant or exercise therapist
- Unrestricted physical activity – start to fly and build up gradually

Physical start

**NOTE** This physical activity clearance is valid for a maximum of six months from the date it is completed and becomes invalid if your medical condition becomes worse



## Appendix H. Personal Medical History Questionnaire

### Type 2 Diabetes

1. When were you diagnosed with type 2 diabetes? \_\_\_\_\_
2. What is your current method of control for type 2 diabetes? \_\_\_\_\_
3. How long have you been using the current method of control? \_\_\_\_\_
4. What were your previous methods of control? (description, dates) \_\_\_\_\_  
\_\_\_\_\_

### Peripheral Arterial Disease (PAD)

1. When were you diagnosed with PAD? \_\_\_\_\_
2. Are you currently taking medication to control PAD-related pain? \_\_\_\_\_  
If yes, how long have you been taking this medication? \_\_\_\_\_
3. Are you performing any activities to help reduce PAD-related pain? \_\_\_\_\_  
If yes, please describe: \_\_\_\_\_

### Exercise

1. Do you exercise regularly? Y/N  
If yes, what type of exercise do you perform and how often? \_\_\_\_\_  
If yes, how long have you been doing this exercise? \_\_\_\_\_
2. Where you active in previous years? Y/N  
If yes, please describe the type of activity and its duration \_\_\_\_\_  
\_\_\_\_\_

### The Study

1. Why did you join this study? \_\_\_\_\_
2. What encouraged you to complete the study's exercise program? \_\_\_\_\_
3. Did you find the exercise program helpful? \_\_\_\_\_

## Appendix I. Release of Medical Information

Department of Kinesiology



### RELEASE OF MEDICAL INFORMATION

I \_\_\_\_\_ authorize \_\_\_\_\_

to release any information regarding my medical condition to :

Martina Kovacevic, BHK  
Department of Kinesiology  
University of Windsor  
HK 240, 410 Sunset Avenue  
Windsor, ON N9B 3P4  
FAX: (519) 973 7056

Signature: \_\_\_\_\_ Date: \_\_\_\_\_

Details of information being requested:

health status with respect to blood pressure, type 2 diabetes, peripheral arterial disease and cardiovascular health during the past twelve (12) months

- I, Martina Kovacevic, have explained the details of the Release of Medical Information Form to the participant

Signature : \_\_\_\_\_

**Appendix J. Automated Arterial Oscillometry Device**

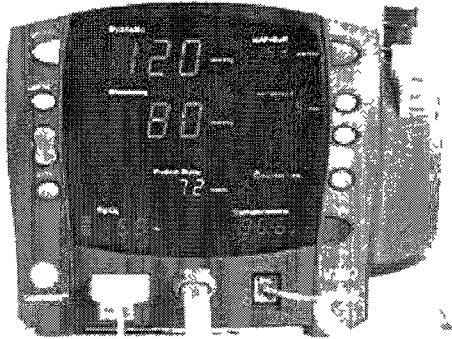

Dinamap ProCare 100, Critikon

## Appendix K. Duplex Ultrasound Machine

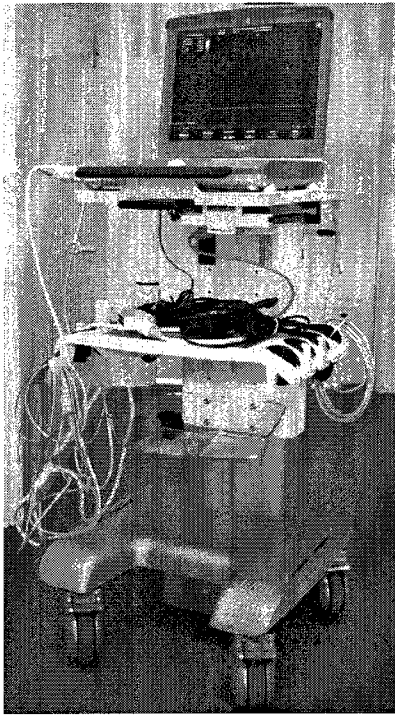

GE Vivid i 0334 Ultrasound Machine

## **Appendix L. Gardner Protocol**

### Gardner Protocol

The Gardner Protocol is a validated test (Gardner et al., 1991) used clinically to assess intermittent claudication with the use of a graded treadmill.

The protocol is as follows:

1. The individual begins to walk on the treadmill at 2 mph at 0% incline.
2. While the individual walks at a constant 2 mph, the treadmill incline will increase by 2% every 2 minutes.
3. The treadmill will continue to incline to a maximum of 14%.
4. As the individual is walking, he/she will notify the investigator when pain and cramping are first felt in the legs (this is the initial claudication distance, ICD).  
The individual will continue to walk.
5. Following the determination of the ICD, the individual will notify the investigator at the appearance of maximal pain and cramping (this is the absolute claudication distance, ACD). The individual will discontinue walking on the treadmill. The ACD may occur before the maximum 14% incline.

Appendix M. Blood Glucose Monitoring System



Abbott FreeStyle Freedom Lite

## Appendix N. Spring-Loaded Lancet

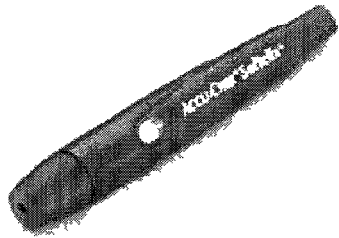

Accu-Chek Softclix

**Appendix O. Lower Leg Isometric Training Apparatus (LoLITA)**

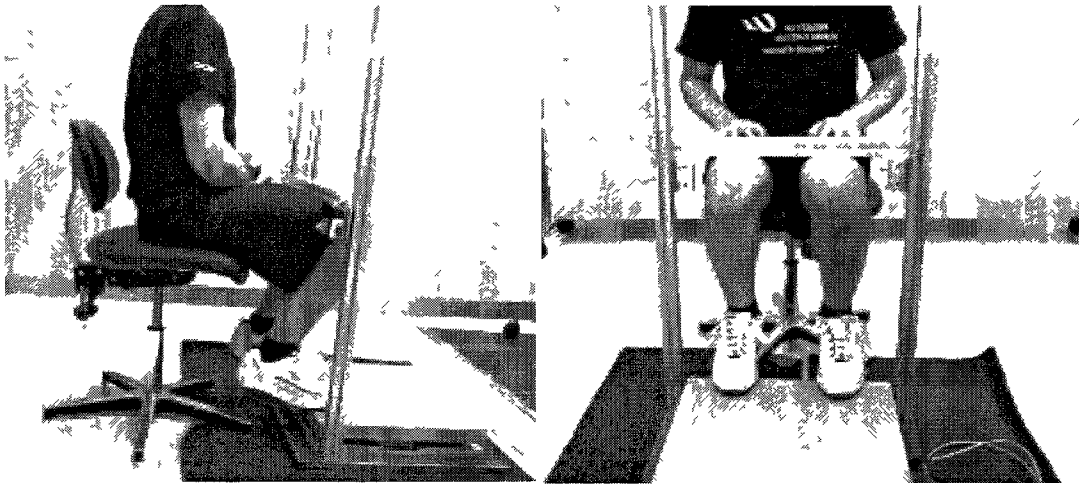

Profile view of LoLITA

Frontal view of LoLITA



## **Vita Auctoris**

Martina Kovacevic was born in Belgrade, Serbia in 1987 and immigrated to Canada in 1992 where she was raised and currently resides. In Windsor, Ontario, she graduated from Vincent Massey Secondary School. Following this, she earned her Bachelor's and Master's degrees in Human Kinetics both from the University of Windsor.