

University of Windsor

Scholarship at UWindor

Electronic Theses and Dissertations

Theses, Dissertations, and Major Papers

8-13-1965

Analysis and Analogue Computer Representation of commutating machines and its application to control systems.

Tilak Raj Sahni
University of Windsor

Follow this and additional works at: <https://scholar.uwindsor.ca/etd>

Recommended Citation

Sahni, Tilak Raj, "Analysis and Analogue Computer Representation of commutating machines and its application to control systems." (1965). *Electronic Theses and Dissertations*. 6402.
<https://scholar.uwindsor.ca/etd/6402>

This online database contains the full-text of PhD dissertations and Masters' theses of University of Windsor students from 1954 forward. These documents are made available for personal study and research purposes only, in accordance with the Canadian Copyright Act and the Creative Commons license—CC BY-NC-ND (Attribution, Non-Commercial, No Derivative Works). Under this license, works must always be attributed to the copyright holder (original author), cannot be used for any commercial purposes, and may not be altered. Any other use would require the permission of the copyright holder. Students may inquire about withdrawing their dissertation and/or thesis from this database. For additional inquiries, please contact the repository administrator via email (scholarship@uwindsor.ca) or by telephone at 519-253-3000ext. 3208.

ANALYSIS AND ANALOGUE COMPUTER REPRESENTATION
OF COMMUTATING MACHINES AND ITS
APPLICATION TO CONTROL SYSTEMS

by

TILAK RAJ SAHNI

A Thesis

Submitted to the Faculty of Graduate Studies through the
Department of Electrical Engineering in Partial Fulfillment
of the Requirements for the Degree of
Master of Applied Science at the
University of Windsor

Windsor, Ontario

1965

UMI Number: EC52583

INFORMATION TO USERS

The quality of this reproduction is dependent upon the quality of the copy submitted. Broken or indistinct print, colored or poor quality illustrations and photographs, print bleed-through, substandard margins, and improper alignment can adversely affect reproduction.

In the unlikely event that the author did not send a complete manuscript and there are missing pages, these will be noted. Also, if unauthorized copyright material had to be removed, a note will indicate the deletion.

UMI®

UMI Microform EC52583

Copyright 2008 by ProQuest LLC.

All rights reserved. This microform edition is protected against unauthorized copying under Title 17, United States Code.

ProQuest LLC
789 E. Eisenhower Parkway
PO Box 1346
Ann Arbor, MI 48106-1346

APPROVED BY:

H. H. Hoang

P. A. V. Thomas

A. L. Smith

123360

ABSTRACT

The purpose of the present study is two-fold:

- i) to present a unified approach for the analysis of both D.C. and A.C. commutating machines.
- ii) to present the rigorous mathematical model and Analogue Computer Representation of both D.C. and A.C. commutating machines.

The analysis begins for an ideal machine with the following assumptions:

- i) The air-gap flux density wave to be sinusoidal
- ii) The effects of the coil short-circuited undergoing commutation to be ignored.
- iii) The magnetic path to be unsaturated

But in the actual machine, the following problems are encountered:

- i) The air-gap flux density wave is non-sinusoidal
- ii) A coil undergoing commutation is short-circuited
- iii) The magnetic path is saturated

To overcome these problems, the voltage-current equations are modified as stated below:

- i) The presence of space harmonic components in the air-gap flux density wave modifies the speed-voltage coefficient in the speed-voltage terms.
- ii) The proper choice of the rotor and stator axes takes care of the effect of short-circuited coil undergoing commutation.
- iii) The saturation in the magnetic path causes the non-linearity in the voltage-current equations. Thus it modifies the inductance

coefficient by a factor S which is found from the open circuit characteristic of the machine. This non-linearity can be simulated in the Analogue Computer Representation by a function generator.

Finally, an application of D.C. commutating machines is shown in the position control system.

ACKNOWLEDGEMENTS

The sincerest appreciation of the author is extended to Dr. H.H. Hwang for his generous provision of guidance and encouragement, and for the wealth of knowledge which he made available to this work. Thanks are due to Dr. P.A.V. Thomas for the encouragement from time to time during the work.

Special thanks are directed to the National Research Council which made possible the execution of this endeavour.

TABLE OF CONTENTS

	Page
ABSTRACT.	iii
ACKNOWLEDGEMENTS.	v
TABLE OF CONTENTS	vi
Chapter	
I. INTRODUCTION.	1
II. Generalized Theory.	2
III. D.C. COMMUTATING MACHINE.	13
IV. A.C. COMMUTATING MACHINE.	36
V. CONCLUSION.	45
REFERENCES.	46
VITA AUCTORIS	47

CHAPTER I

INTRODUCTION

The characteristics of variable speed with change of armature voltage of a D.C. machine have led to its many important uses. Its superiority is shown over other types of machines in the control system application. In the position and velocity control, D.C. machines are used in most cases.

Therefore, such a need of a D.C. machine has led to its rigorous study and its representation by a mathematical model. The analysis is proceeded with two axes (d-q axes) theory and, therefore, a most general D.C. machine, having field and armature windings and brushes placed on both the axes is studied.

In the study of commutating machine, the following three difficulties are encountered:

1. The Air-gap flux density wave is non-sinusoidal.
2. A coil undergoing commutation is short circuited.
3. The Magnetic path is saturated.

In the present study, all these factors are taken into special consideration. The Analogue Computer representation has been presented for a general machine known as a Metadyne and then for an Amplidyne. An application of the D.C. Commutating machine is shown in the position control system.

Further analysis has been proceeded to study the A.C. Commutating machines, such as the Repulsion Motor and the Single phase A.C. Series motor. For these two motors an Analogue Computer representation has been presented.

CHAPTER II

GENERALIZED THEORY

2.1 Ideal Machine

A most general commutating machine, shown in Fig.2.1, represents windings as equivalent coils placed on two orthogonal axes. All the windings shown either exist physically or represent an equivalent of some phenomena occurring in the machine. It is possible that there may be more or less number of windings than those shown on each axis. There are also two sets of brushes placed 90 electrical degrees apart on the commutator for generalization, which are actually present in the cross-field machines.

The two orthogonal axes shown in Fig.2.1, are chosen as stationary axes and defined as

- i) Direct Axis (or Pole axis) - Axis of the main field winding.
- ii) Quadrature Axis (or Interpolar axis) - An axis 90 electrical degrees ahead of Direct-axis. Sometimes it is known as the Brush Axis.

The analysis begins with an idealized machine and later is modified when actual difficulties are encountered. Hence it proceeds with the following assumptions:

- i) The Air-gap flux density wave to be sinusoidal
- ii) The Magnetic path to be unsaturated
- iii) Hysteresis and Eddy current losses to be neglected
- iv) Effects of the coil to be short-circuited as commutation is to be ignored.

With the above stated assumptions, the voltage induced in the coil

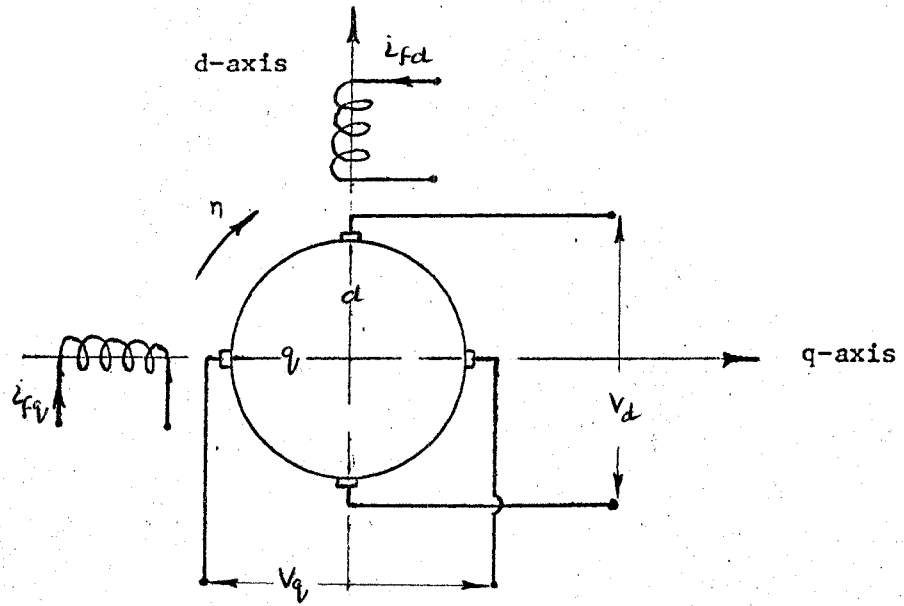

Fig. 2.1 A Generalized Commutating Machine

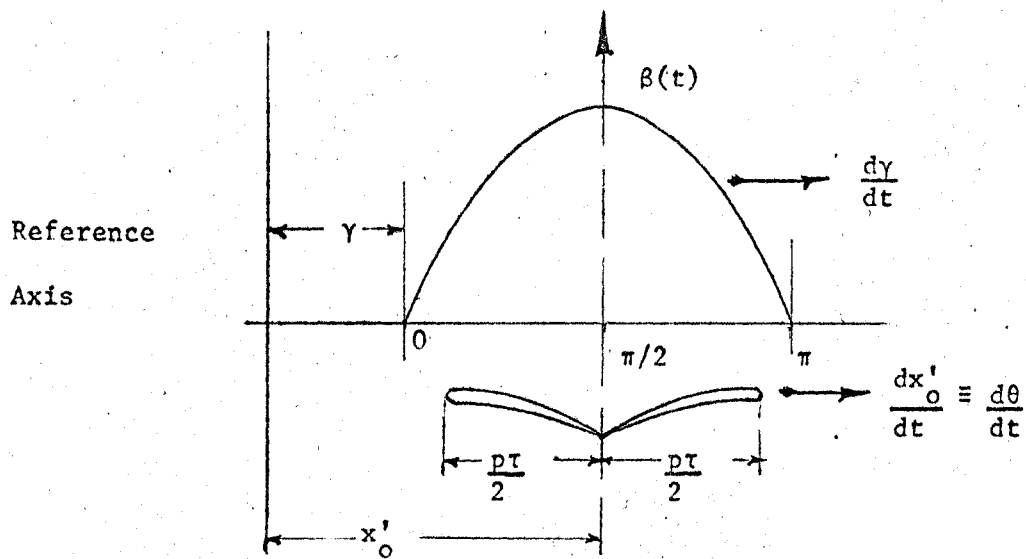

Fig. 2.2 A Single Coil In The Field

whose centre is located at x'_0 from the reference axis is to be found.

Here the most general case is considered so that

i) flux density is a function of time

ii) flux density is moving with the velocity of $\frac{dy}{dt}$

iii) A coil of short pitch $p\tau$ is placed on the armature which rotates with a velocity $\frac{d\theta}{dt}$.

To find the voltage induced in the coil, the flux-linkage with the coil is first found and then its time-derivative is taken to find the induced e.m.f.

Therefore, flux embraced with the coil,

$$\phi = \int_{-\frac{l}{2}}^{\frac{l}{2}} \int_{x'}^{x''} \beta \, dx \, dy \quad \dots 2.1$$

l - axial length of armature

x' and x'' - distances of two ends of the coil from the reference axis

β - flux density which is a function of time and space; and it is given as

$$\beta = \beta_m \sin \left(\frac{\pi x}{\tau} + \gamma \right) \quad \dots 2.2$$

$$\phi = \frac{2\tau}{\pi} l K_p K_s \beta_m \sin \left(\frac{\pi x'_0}{\tau} + \gamma \right) \quad \dots 2.3$$

$$\text{where } K_p = \sin \frac{p\pi}{2} \text{ - pitch factor} \quad \dots 2.4$$

$$K_s = \frac{2\tau}{\pi l \tan \alpha} \sin \left(\frac{\pi l}{2\tau} \tan \alpha \right) \text{ - skew factor} \quad \dots 2.5$$

α - skew angle

$$\text{or } \phi = K_p K_s \phi_m \sin \left(\frac{\pi x'_o}{\tau} + \gamma \right) \quad \dots 2.6$$

$$\text{where } \phi_m = \frac{2\tau}{\pi} l \beta_m \quad \dots 2.7$$

from the equation 2.6, it is seen that flux embraced by the coil is a function of ϕ_m , x'_o , γ i.e.,

$$\phi = f(\phi_m, x'_o, \gamma) \quad \dots 2.8$$

The voltage induced in the coil,

$$e = -N \frac{d\phi}{dt} \quad \dots 2.9$$

$$= -N K_p K_s \left\{ \frac{\delta \phi'_m}{\delta t} \sin \left(\frac{\pi x'_o}{\tau} + \gamma \right) + \phi_m \left[\frac{\pi}{\tau} \frac{\delta x'_o}{\delta t} + \frac{\delta \gamma}{\delta t} \right] \cos \left(\frac{\pi x'_o}{\tau} + \gamma \right) \right\} \quad \dots 2.10$$

Consider a group of q coils uniformly distributed in slots separated by a slot angle σ and the centre of the group is located at x_o from the reference axis. The voltage induced in the group of coils is,

$$e = -N K_p K_s K_d q \left\{ \frac{\delta \phi_m}{\delta t} \sin \left(\frac{\pi x_o}{\tau} + \gamma \right) + \phi_m \left[\frac{\pi}{\tau} \frac{\delta x_o}{\delta t} + \frac{\delta \gamma}{\delta t} \right] \cos \left(\frac{\pi x_o}{\tau} + \gamma \right) \right\} \quad \dots 2.11$$

$$\text{and } K_w = K_p K_s K_d \text{ - winding factor} \quad \dots 2.12$$

$$N_e = N K_w q \text{ - Effective number of turns} \quad \dots 2.13$$

$$\psi_m = N_e \phi_m \text{ - flux linkage} \quad \dots 2.14$$

The equation 2.11 can be rewritten as

$$e = - \left\{ \frac{\delta \psi_m}{\delta t} \sin \left(\frac{\pi x_o}{\tau} + \gamma \right) + \psi_m \left[\frac{\pi}{\tau} \frac{\delta x_o}{\delta t} + \frac{\delta \gamma}{\delta t} \right] \cos \left(\frac{\pi x_o}{\tau} + \gamma \right) \right\} \quad \dots 2.15$$

The three terms in equation 2.15 are interpreted as

- i) The term $\frac{\delta \psi_m}{\delta t}$ represents transformer e.m.f.
- ii) The term $\frac{\delta x_o}{\delta t}$ represents speed e.m.f. due to movement of conductors.
- iii) The term $\frac{\delta \gamma}{\delta t}$ represents speed e.m.f. due to movement of field.

In all the commutating machines, the field must be stationary while the armature is rotating.

$$\text{Thus } \frac{d\gamma}{dt} = 0 \quad \dots 2.16$$

In the generalized machine as stated earlier, there are two sets of windings on two axes, therefore the flux distribution is as shown in Fig. 2.3.

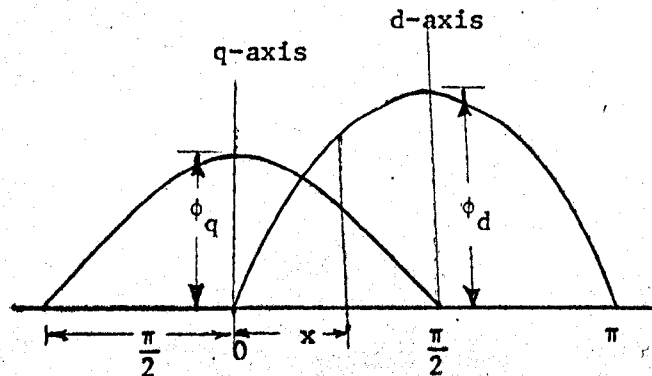

Fig. 2.3 Flux Distribution On Both Axes

Thus the flux at any point is

$$\phi(x) = \phi_q \sin \left(\frac{\pi x}{\tau} + \frac{\pi}{2} \right) + \phi_d \sin \frac{\pi x}{\tau} \quad \dots 2.17$$

or

$$\psi(x) = \psi_q \sin \left(\frac{\pi x}{\tau} + \frac{\pi}{2} \right) + \psi_d \sin \frac{\pi x}{\tau} \quad \dots 2.18$$

The voltages e_d , e_q induced in the windings placed on d-axis and q-axis are respectively

$$e_d = - \frac{d\psi_d}{dt} + \psi_q \frac{d\theta}{dt} \quad \dots 2.19$$

$$e_q = - \psi_d \frac{d\theta}{dt} - \frac{d\psi_q}{dt} \quad \dots 2.20$$

The armature terminal voltages are

$$v_d = e_d - i_d r_a = - \frac{d\psi_d}{dt} + \psi_q \frac{d\theta}{dt} - i_d r_a \quad \dots 2.21$$

$$v_q = - e_q - i_q r_a = - \psi_d \frac{d\theta}{dt} - \frac{d\psi_q}{dt} - i_q r_a \quad \dots 2.22$$

The flux linkages ψ_d and ψ_q can be written in terms of self and mutual inductances of the coils on the two axes, for in the unsaturated magnetic path, a linear relation between flux linkage and the current exists.

2.2 Practical Machine and Problems Encountered

In the previous section, theory is developed for an ideal machine under the assumptions made, but the machine is not ideal and a number of problems are encountered in the actual machine. It is difficult to develop the theory for an actual machine, therefore, a theory is first developed for an ideal machine where the equations are obtained in correct form and then certain factors are modified for the actual machine. The following problems are encountered in the actual commutating machine:

1. Space harmonics in the air-gap flux density

2. The coil undergoing commutation is short-circuited
3. Saturation of the magnetic path
- 1) Space-harmonics in the air-gap flux density:-

The flux density distribution in the air-gap is not sinusoidal but it contains space harmonics. The equations for e.m.f. induced are derived on the assumption of a fundamental air-gap flux density. By inspecting the voltage equations (nos. 2.21 and 2.22), it is found that they contain two terms - (a) Transformer-voltage - $\frac{d\psi}{dt}$ and (b) speed-voltage - $\psi \frac{d\theta}{dt}$.

The speed-voltage term is more predominant than the transformer-voltage term. Thus the correction for transformer-voltage is not of much importance. To modify this term a lot of problems are involved in finding the exact flux density wave shape, its harmonic component and the voltage due to each component. This process is very labourious and the result can be obtained with sufficient accuracy by considering only the fundamental component.

The second term is speed-voltage, $\psi \frac{d\theta}{dt}$ where flux linkage ψ is of the form $\psi = Mi$..2.23

where M is mutual inductance in the case when only fundamental component is considered. For non-sinusoidal flux density M does not remain as the mutual inductance coefficient but is to be modified. This coefficient is known as speed-voltage-coefficient- G which is to be found experimentally. Thus the voltage equations (2.21) and (2.22) become

$$v_d = - \frac{d\psi_d}{dt} + \lambda_q \frac{d\theta}{dt} - i_d r_a \quad \dots 2.24$$

$$v_q = - \lambda_d \frac{d\theta}{dt} + \frac{d\psi_d}{dt} - i_q r_a \quad \dots 2.25$$

where λ_d and λ_q are of the form $\lambda = Gi$ while G is the speed-voltage coefficient.

2) Short-circuited Coil Under Commutation.

During the process of commutation, coils are being short-circuited. These short-circuited coils set up a field in the air-gap. The coils short-circuited by brushes placed in the d-axis produce a field in the q-axis, and vice-versa. Thus the effects of short-circuited coils can be considered along with the fields in both the axes while measuring the constants of the machines. This line of approach is true only when the axes of the rotor are chosen to coincide with the corresponding axes of the stator.

3) Saturation of Magnetic Path.

In the actual machine, the magnetic path is considered saturated (and in fact in the self-excited D.C. machine the magnetic circuit must be saturated). The saturation has two effects: (1) reduction of inductance and (2) reduction of voltage generated in the armature circuit.

The effect of saturation can be considered with the approximation that there is no interaction between the flux at the d-axis and that at the q-axis. Recalling the relation

$$\psi_{\text{mdf}} = A \frac{(v_{\text{qa}})_{\text{oc}}}{\eta} \quad \dots 2.26$$

where ψ_{mdf} - field flux linking with d-axis circuit

A - Constant of proportionality

$(v_{\text{qa}})_{\text{oc}}$ - Open-circuit armature voltage in q-axis

η - speed in radians per sec.

A curve between the d-axis field current, and the q-axis open-circuit armature voltage per radian per second of speed will give the measure of saturation at the d-axis. This curve gives the relation between ψ_{mdf}

and i_{fd} . A typical curve is shown in Fig. 2.4.

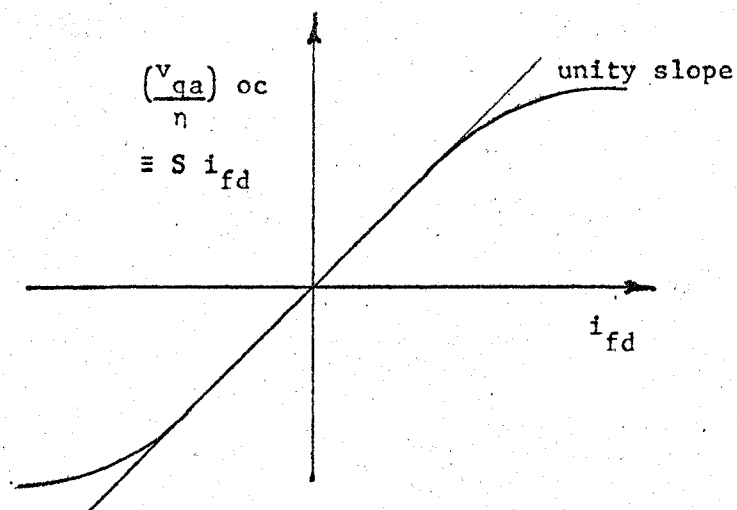

Fig. 2.4. S. Saturation Curve

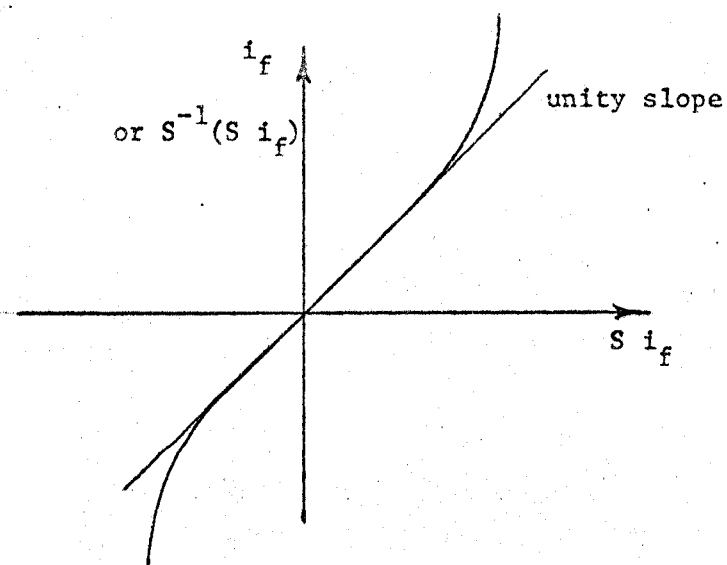

Fig. 2.5. S^{-1} - Inverse Saturation Curve

The self inductance of the field winding is related as

$$L_{fd} = L_{fld} + L_{mfd}$$

where L_{fld} is inductance due to leakage flux which does not link with the armature circuit and L_{mfd} is the inductance due to mutual flux and it is

$$L_{mfd} = \frac{\psi_{mfd}}{i_{fd}} \quad \dots 2.28$$

Hence, a relation between open circuit voltage and inductance is established as given below.

$$\begin{aligned} A \frac{(v_{qa})_{oc}}{\eta} &= \psi_{mfd} \equiv L_{mfd} i_{fd} \equiv \frac{L_{mfd}}{L'_{mfd}} i_{fd} \quad \dots 2.29 \\ &= S i_{fd} \\ &= \frac{G_{af}}{G'_{af}} i_{fd} \end{aligned}$$

where L'_{mfd} is inductance of unsaturated portion and is considered to be constant.

Because of saturation, the flux is reduced and hence the speed voltage is also reduced. This is allowed for by the speed-voltage coefficient G_{af} , and G'_{af} which is a constant speed-voltage coefficient found from the unsaturated conditions. Therefore, by finding S which is a function of field current, the values of

$$L_{mfd} = S L'_{mfd}$$

and $G_{af} = S G'_{af}$

can be obtained.

Thus in the voltage equations, mutual inductance coefficients and speed-voltage-coefficients are replaced accordingly. In these expressions

for finding the differentials, the term $\frac{ds}{dt}$ is assumed to be negligible.

Hence the effect of saturation is appropriately accounted for. In Analogue representation, the inverse saturation factor S^{-1} is required which is defined by interchanging the axes of Fig. 2.4. Thus S^{-1} is obtained in the Fig. 2.5. In the analogue representation, this can be represented by a function generator.

In the two axes machines, two saturation factors S_d and S_q (or S_d^{-1} and S_q^{-1}) are defined for two axes. The S_d^{-1} is determined from $(v_{qa})_{oc}$ versus the direct axis field current i_{fd} , and S_q^{-1} is determined from $(v_{da})_{oc}$ versus the quadrature axis field current i_{fq} .

CHAPTER III

D.C. COMMUTATING MACHINE

An ordinary D.C. machine is a basic type of commutating machine. There are various methods of connections between field and armature circuits giving different types of characteristics. A typical D.C. Commutating Machine is a separately excited generator in which the output voltage is influenced by the change of input voltage. These two machines can be connected in cascade to obtain more power amplification. Later cross-field machines were developed to give more amplification. This gives two states of power amplification without using two separate machines. Fig. 3.1 shows the schematic diagram of a cross-field machine.

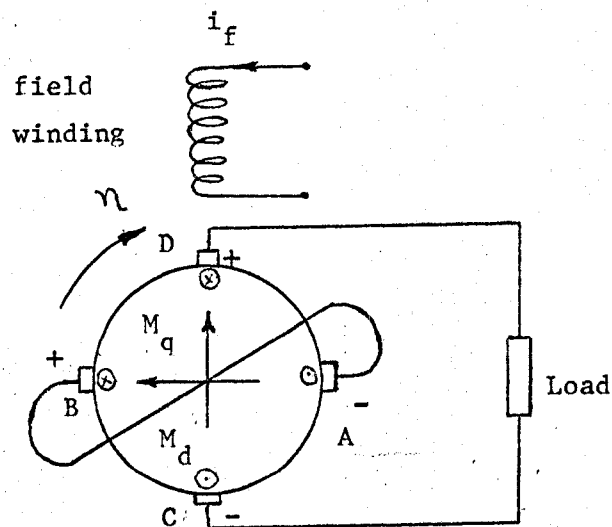

Fig. 3.1. A Cross Field Machine

With the armature running in clockwise direction, voltage of marked polarity is induced in the brushes A and B. If these brushes are short circuited, a large amount of current flows in the armature conductors, setting up a M.M.F. - M_q in the direction shown, which produces flux perpendicular to the main flux. If a pair of brushes C and D are placed perpendicular to the axis of AB, voltage is induced in these brushes C and D due to rotation of armature. The load can be connected across the brushes C and D. This in short is a principle of cross-field machine. These can be classified as two-stage machines also.

In general, a Metadyne generator can represent a cross-field machine. Another type of cross-field generator is the Amplidyne in which compensating windings are provided on the stator. These compensating windings carry the load current and produce an M.M.F. equal and opposite to M_d (due to armature reaction). Thus, the net flux remains constant. Therefore, the Amplidyne is known as a constant-voltage generator. In the Metadyne, lack of compensating winding results in negative feedback. The negative feedback introduces two serious problems. There is much less power amplification in Metadyne compared to Amplidyne. The problem of oscillation is overcome by providing additional damping winding.

Another difference is that speed of response of Metadyne Generator is rapid in comparison to the response of either a separately excited D.C. machine or an Amplidyne. Eddy currents in the iron path, though minimized by lamination, can be represented by a short circuited winding. Eddy currents have a small effect in transient response. Eddy currents, if not minimized, may have beneficial effect upon damping.

Considering all the above stated points, a generalized Metadyne is shown in Fig. 3.2.

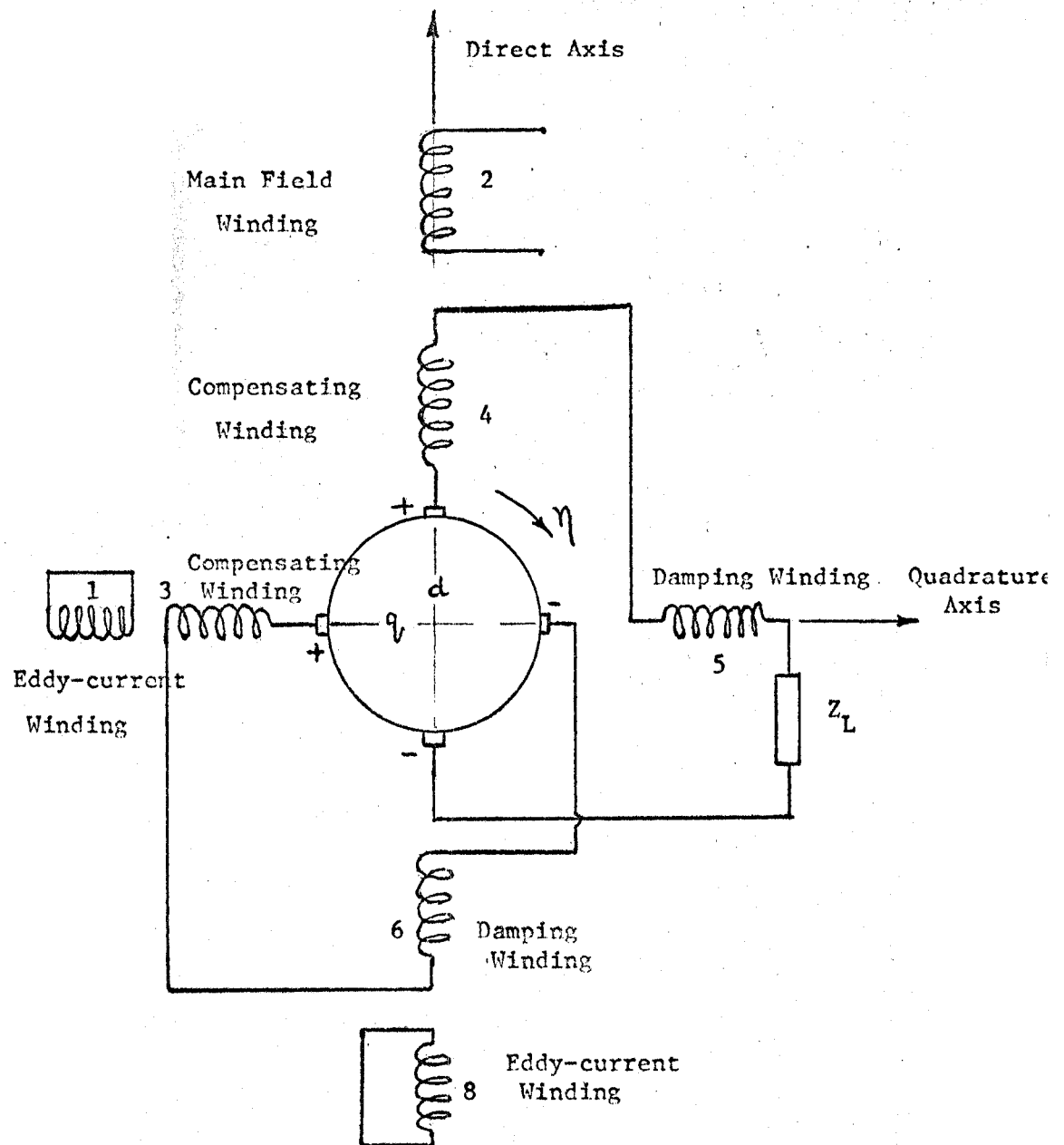

Fig. 3.2. A Generalized Metadyne Generator

Direct Axis Windings:

- 2 - Main Field Winding
- 4 - Compensating Winding in series with the d-axis armature winding.
It produces an M.M.F. in the same direction as the M.M.F. of the d-axis armature winding.
- d - Direct axis armature winding
- 6 - Damping winding connected in series with the q-axis armature winding and placed in the d-axis
- 8 - Short-circuited fictitious winding for eddy current path in the d-axis
- Z_L - Load Circuit

Quadrature Axis Windings:

- 1 - Short circuited fictitious winding for eddy current path in the q-axis
- 3 - Compensating Winding in series with the q-axis armature winding. The M.M.F. is in the direction of the M.M.F. due to the q-axis armature winding.
- q - Quadrature-axis armature winding
- 5 - Damper winding in series with the d-axis winding and placed in the q-axis

As found out in the previous chapter, the voltage induced in the d-axis and q-axis windings are of the form 2.24 and 2.25, under the condition of non-sinusoidal flux density distribution. But still, two

are deriving these equations:

- 1) Speed of Metadyne is constant
- 2) Magnetic circuits are unsaturated

Rewriting the equations 2.24 and 2.25

$$v_d = - \frac{d\psi_d}{dt} + \lambda_q \frac{d\theta}{dt} - i_d r_a \quad \dots 3.1$$

$$v_q = -\lambda_d \frac{d\theta}{dt} - \frac{d\psi_q}{dt} - i_q r_a \quad \dots 3.2$$

Thus, to derive the voltage equations, first the flux-linkage with each circuit is found. The subscript denotes the corresponding circuit.

$$\psi_2 = L_2 i_2 + M_{42} i_4 + M_{d2} i_d + M_{62} i_6 + M_{82} i_8 \quad \dots 3.3$$

$$\psi_4 = M_{24} i_2 + L_4 i_4 + M_{d4} i_d + M_{64} i_6 + M_{84} i_8 \quad \dots 3.4$$

$$\psi_d = M_{2d} i_2 + M_{4d} i_4 + L_d i_d + M_{6d} i_6 + M_{8d} i_8 \quad \dots 3.5$$

$$\psi_6 = M_{62} i_2 + M_{64} i_4 + M_{6d} i_d + L_6 i_6 + M_{68} i_8 \quad \dots 3.6$$

$$\psi_8 = M_{82} i_2 + M_{84} i_4 + M_{8d} i_d + M_{86} i_6 + L_8 i_8 \quad \dots 3.7$$

$$\psi_1 = L_1 i_1 + M_{13} i_3 + M_{1q} i_q + M_{15} i_5 \quad \dots 3.8$$

$$\psi_3 = M_{31} i_1 + L_3 i_3 + M_{3q} i_q + M_{35} i_5 \quad \dots 3.9$$

$$\psi_q = M_{q1} i_1 + M_{q3} i_3 + L_q i_q + M_{q5} i_5 \quad \dots 3.10$$

$$\psi_5 = M_{51} i_1 + M_{53} i_3 + M_{5q} i_q + L_5 i_5 \quad \dots 3.11$$

Coefficients for speed terms:

$$\lambda_d = G_{22} i_2 + G_{44} i_4 + G_{dd} i_d + G_{66} i_6 + G_{88} i_8 \quad \dots 3.12$$

$$\lambda_q = G_{11} i_1 + G_{33} i_3 + G_{qq} i_q + G_{55} i_5 \quad \dots 3.13$$

Now voltage equation for each of the circuits is shown in the following:

$$v_2 = r_2 i_2 + p L_2 i_2 + p M_{42} i_4 + p M_{d2} i_d + p M_{62} i_6 + p M_{82} i_8 \quad \dots 3.14$$

$$v_4 = -p M_{24} i_2 - p L_4 i_4 - p M_{d4} i_d - p M_{64} i_6 - p M_{84} i_8 - r_4 i_4 \quad \dots 3.15$$

$$v_d = -p M_{2d} i_2 - p M_{4d} i_4 - p L_d i_d - p M_{6d} i_6 - p M_{8d} i_8 + (G_1 i_1 + G_3 i_3 + G_q i_q + G_5 i_5) n - i_d r_d \quad \dots 3.16$$

$$v_6 = -p M_{62} i_2 - p M_{64} i_4 - p M_{6d} i_d - p L_6 i_6 - p M_{86} i_8 - i_6 r_6 \quad \dots 3.17$$

$$v_8 = -p M_{82} i_2 - p M_{84} i_4 - p M_{8d} i_d - p M_{86} i_6 - p L_8 i_8 - i_8 r_8 \quad \dots 3.18$$

$$v_1 = -p L_1 i_1 - p M_{13} i_3 - p M_{1q} i_q - p M_{15} i_5 - i_1 r_1 \quad \dots 3.19$$

$$v_3 = -p M_{31} i_1 - p L_3 i_3 - p M_{3q} i_q - p M_{35} i_5 - i_3 r_3 \quad \dots 3.20$$

$$v_q = -(G_2 i_2 + G_4 i_4 + G_d i_d + G_6 i_6 + G_8 i_8) n - p M_{q1} i_1 - p M_{q3} i_3 - p L_q i_q - p M_{q5} i_5 - i_q r_a \quad \dots 3.21$$

$$v_5 = -p M_{51} i_1 - p M_{53} i_3 - p M_{5q} i_q - p L_5 i_5 - i_5 r_5 \quad \dots 3.22$$

$$v_L = \begin{pmatrix} R_L + pL \\ L \end{pmatrix} i_L \quad \dots 3.23$$

For open-circuits and steady state case, speed voltages are:

$$v_{do} = (+G_1 i_1 + G_3 i_3 + G_q i_q + G_5 i_5) n \quad \dots 3.24$$

$$v_{qo} = - (G_2 i_2 + G_4 i_4 + G_d i_d + G_6 i_6 + G_8 i_8) n \quad \dots 3.25$$

when saturation is considered, the equations 3.24 and 3.25 are modified to:

$$v_{do} = (+ G_1' i_1 + G_3' i_3 + G_q' i_q + G_5' i_5) n S_q \quad \dots 3.26$$

$$v_{qo} = - (G_2' i_2 + G_4' i_4 + G_d' i_d + G_6' i_6 + G_8' i_8) n S_d \quad \dots 3.27$$

3.2 Analogue Representation of Metadyne

The Metadyne with all these windings can be simulated on an Analogue Computer. For the Analogue representation, the equations 3.14 through 3.23 are modified under the following conditions:

1) The self-inductance of each winding can be written as a sum of leakage inductance and mutual inductance. Hence for Kth winding

$$L_K = L_{K1} + L_{KK} \quad \dots 3.28$$

where L_{K1} is leakage inductance of winding due to leakage flux, and it is assumed to be constant, and L_{KK} is mutual inductance of winding K due

to mutual flux. The mutual inductance is defined as $L_{KK} = \frac{\psi_m}{i_K}$

..3.29

where ψ_m - mutual flux and i_K - current in the winding.

2) Same mutual flux links with all the windings on the same axis. This assumption is reasonable because all the field windings are physically wound on the same structure. This condition results in the following relations:

$$\frac{L_{KK}}{N_K^2} = \frac{L_{Kj}}{N_K N_j} \text{ or } L_{Kj} = \frac{N_j}{N_K} L_{KK} \quad \dots 3.30$$

where N_K and N_j are the number of turns in windings K and j respectively.

3) Since the speed voltage is proportional to mutual flux, and mutual flux being the same for all the windings, a relation among speed coefficients is:

$$\frac{G_K}{N_K} = \frac{G_j}{N_j} \quad \dots 3.31$$

4) Speed of amplidyne is constant

5) The equations and Analogue representation diagram are first derived on the assumption of no saturation and then are modified later for saturation according to Chapter II.

By substituting equations 3.24, 3.25, 3.28, 3.31 into equations 3.14 to 3.23, the following relations are obtained

$$v_2 = Z_2 i_2 - p \frac{L_{22}}{G_2} \left(\frac{v_{qa}}{\eta} \right)$$

$$\text{or } \frac{v_2 G_2}{Z_2} = G_2 i_2 - p \frac{L_{22}}{Z_2} \left(\frac{v_{qo}}{\eta} \right) \quad \dots 3.32$$

$$v_4 = p \frac{L_{44}}{G_4} \left(\frac{v_{qo}}{\eta} \right) - Z_4 i_4$$

$$\text{or } \frac{v_4 G_4}{Z_4} = -G_4 i_4 + p \frac{L_{44}}{Z_4} \left(\frac{v_{qo}}{\eta} \right) \quad \dots 3.33$$

$$v_d = \frac{pL_{dd}}{G_d} \left[\frac{v_{qo}}{\eta} \right] + v_{do} - Z_d i_d$$

$$\text{or } \frac{v_d - v_{do} G_d}{Z_d} = -G_d i_d + \frac{pL_{dd}}{Z_d} \left[\frac{v_{qo}}{\eta} \right] \quad \dots 3.34$$

$$v_6 = -Z_6 i_6 + p \frac{pL_{66}}{G_6} \left[\frac{v_{qo}}{n} \right]$$

or

$$\frac{v_6}{Z_6} G_6 = -G_6 i_6 + p \frac{pL_{66}}{Z_6} \left[\frac{v_{qo}}{n} \right] \quad \dots 3.35$$

$$\frac{v_8}{Z_8} G_8 = -G_8 i_8 + \frac{pL_{88}}{Z_8} \left[\frac{v_{qo}}{n} \right] \quad \dots 3.36$$

Adding equations 3.32 through 3.36,

$$\begin{aligned} & -\frac{v_2 G_2}{Z_2} + \frac{v_4 G_4}{Z_4} + \frac{v_d - v_{do}}{Z_d} G_d + \frac{v_6}{Z_6} G_6 + \frac{v_8}{Z_8} G_8 \\ & = -G_2 i_2 - G_4 i_4 - G_d i_8 - G_6 i_6 - G_8 i_8 + \left[\frac{pL_{22}}{Z_2} + \frac{pL_{44}}{Z_4} \right. \\ & \quad \left. + \frac{pL_{dd}}{Z_d} + \frac{pL_{66}}{Z_6} + \frac{pL_{88}}{Z_8} \right] \left[\frac{v_{qo}}{n} \right] \\ & = \frac{v_{qo}}{n} + \left[\frac{pL_{22}}{Z_2} + \frac{pL_{44}}{Z_4} + \frac{pL_{dd}}{Z_d} + \frac{pL_{66}}{Z_6} + \frac{pL_{88}}{Z_8} \right] \left[\frac{v_{qo}}{n} \right] \end{aligned} \quad \dots 3.37$$

Quadrature-Axis

$$v_1 = -i_1 z_1 - \frac{pL_{11}}{G_1} \left[\frac{v_{do}}{n} \right]$$

or

$$\frac{v_1}{Z_1} G_1 = -i_1 G_1 - \frac{pL_{11}}{Z_1} \left[\frac{v_{do}}{n} \right] \quad \dots 3.38$$

$$v_3 = -i_3 z_3 - \frac{pL_{33}}{G_3} \left[\frac{v_{do}}{n} \right]$$

$$\text{or } \frac{v_3}{Z_3} G_3 = -i_3 G_3 - \frac{pL_{33}}{Z_3} \left[\frac{v_{do}}{n} \right] \quad \dots 3.39$$

$$v_q = v_{qo} - \frac{pL_{qq}}{G_q} \left[\frac{v_{do}}{n} \right] - i_q Z_q$$

$$\text{or } \frac{v_q - v_{qo}}{Z_q} G_q = -i_q G_q - \frac{pL_{qq}}{Z_q} \left[\frac{v_{do}}{n} \right] \quad \dots 3.40$$

$$v_5 = -\frac{pL_{55}}{G_5} \left[\frac{v_{do}}{n} \right] - i_5 Z_5$$

$$\text{or } \frac{v_5 G_5}{Z_5} = -i_5 G_5 - \frac{pL_{55}}{Z_5} \left[\frac{v_{do}}{n} \right] \quad \dots 3.41$$

Adding equations 3.38 through 3.41,

$$\begin{aligned} & \frac{v_1}{Z_1} G_1 + \frac{v_3 G_3}{Z_3} + \frac{v_q - v_{qo}}{Z_q} G_q + \frac{v_5 G_5}{Z_5} \\ &= - \left[i_1 G_1 + i_3 G_3 + i_q G_q + i_5 G_5 \right] \\ &+ \left[\frac{pL_{11}}{Z_1} + \frac{pL_{33}}{Z_3} + \frac{pL_{qq}}{Z_q} + \frac{pL_{55}}{Z_5} \right] \left[-\frac{v_{do}}{n} \right] \\ &= \left[-\frac{v_{do}}{n} \right] + \left[\frac{pL_{11}}{Z_1} + \frac{pL_{33}}{Z_3} + \frac{pL_{qq}}{Z_q} + \frac{pL_{55}}{Z_5} \right] \left[-\frac{v_{do}}{n} \right] \quad \dots 3.42 \end{aligned}$$

Referring to Fig. 3.2, the following relations also exist.

$$v_1 = 0 ; \quad v_8 = 0 \quad \dots 3.43$$

$$i_4 = i_5 = i_d = -i_L \quad \dots 3.44$$

$$i_3 = i_6 = i_q \quad \dots 3.45$$

$$v_3 + v_q + v_6 = 0 \quad \dots 3.46$$

$$v_4 + v_d + v_5 + v_L = 0$$

$$\text{or } v_L = - \left(v_4 + v_5 + v_d \right) \quad \dots 3.47$$

Thus the equations 3.37 and 3.42 are modified to:

$$\begin{aligned} & \frac{-v_2 G_2 + v_4 G_4 + v_d - v_{do} G_d + v_6 G_6}{z_2 \quad z_4 \quad z_d \quad z_6} \\ & = \left[\frac{v_{qo}}{\eta} \right] + \left[\frac{pL_{22}}{z_2} + \frac{pL_{44}}{z_4} + \frac{pL_{dd}}{z_d} + \frac{pL_{66}}{z_6} + \frac{pL_{88}}{z_8} \right] \left[\frac{v_{qo}}{\eta} \right] \quad \dots 3.48 \end{aligned}$$

$$\begin{aligned} & \frac{v_3 G_3 + v_q - v_{qo} G_q + v_5 G_5}{z_3 \quad z_q \quad z_5} \\ & = - \left[\frac{v_{do}}{\eta} \right] - \left[\frac{pL_{11}}{z_1} + \frac{pL_{33}}{z_3} + \frac{pL_{qq}}{z_q} + \frac{pL_{55}}{z_5} \right] \left[\frac{v_{do}}{\eta} \right] \quad \dots 3.49 \end{aligned}$$

Effect of Saturation:-

As discussed in Chapter II, the effect of saturation is considered in the analysis of the machine. In this case saturation is effective on both axes and so the coefficients of saturation (S) are found out separately for the d-axis (S_d) and the q-axis (S_q). S_d is found by measuring the rotor open circuit voltage on the q-axis when a current is passed in the stator-circuits of the d-axis, and similarly S_q is found by the d-axis open circuit voltage with a current in the q-axis stator circuits.

Thus the equations 3.32 through 3.49 are rewritten, taking the saturation into account.

$$v_2 = z_2 i_2 - \frac{L'_{22}}{G'_2} p \left[\frac{v_{qo}}{\eta} \right] \quad \dots 3.50a$$

$$\text{or } \frac{v_2 G'_2}{z_2} = G'_2 i_2 + \frac{L'_{22}}{z_2} p \left[\frac{v_{qo}}{\eta} \right] \quad \dots 3.50b$$

$$v_4 = -Z_4 i_4 + \frac{L'_{44}}{G'_4} p \left[\frac{v_{qo}}{n} \right] \quad \dots 3.51a$$

or

$$\frac{v_4 G'_4}{Z_4} = -G'_4 i_4 + \frac{L'_{44}}{Z_4} p \left[\frac{v_{qo}}{n} \right] \quad \dots 3.51b$$

$$v_d - v_{do} = -Z_d i_d + \frac{L'_{dd}}{G'_d} p \left[\frac{v_{qo}}{n} \right] \quad \dots 3.52a$$

or

$$\frac{v_d - v_{do}}{Z_d} G'_d = -G'_d i_d + \frac{L'_{dd}}{Z_d} p \left[\frac{v_{qo}}{n} \right] \quad \dots 3.52b$$

$$v_6 = -Z_6 i_6 + \frac{L'_{66}}{G'_6} p \left[\frac{v_{qo}}{n} \right] \quad \dots 3.53a$$

or

$$\frac{v_6 G'_6}{Z_6} = -G'_6 i_6 + \frac{L'_{66}}{Z_6} p \left[\frac{v_{qo}}{n} \right] \quad \dots 3.53b$$

$$0 = -Z_8 i_8 + \frac{L'_{88}}{G'_8} p \left[\frac{v_{qo}}{n} \right] \quad \dots 3.54a$$

or

$$0 = -G'_8 i_8 + \frac{L'_{88}}{Z_8} p \left[\frac{v_{qo}}{n} \right] \quad \dots 3.54b$$

Adding equations 3.50b through 3.54b:

$$\begin{aligned} & -\frac{v_2 G'_2}{Z_2} + \frac{v_4 G'_4}{Z_4} + \frac{v_d - v_{do}}{Z_d} G'_d + \frac{v_6 G'_6}{Z_6} \\ & = - \left[G'_2 i_2 + G'_4 i_4 + G'_d i_d + G'_6 i_6 + G'_8 i_8 \right] \\ & + \left[\frac{L'_{22}}{Z_2} + \frac{L'_{44}}{Z_4} + \frac{L'_{dd}}{Z_d} + \frac{L'_{66}}{Z_6} + \frac{L'_{88}}{Z_8} \right] p \left[\frac{v_{qo}}{n} \right] \\ & = S_d^{-1} \left[\frac{v_{qo}}{n} \right] + \left[\frac{L'_{22}}{Z_2} + \frac{L'_{44}}{Z_4} + \frac{L'_{66}}{Z_6} + \frac{L'_{88}}{Z_8} + \frac{L'_{dd}}{Z_d} \right] p \left[\frac{v_{qo}}{n} \right] \quad \dots 3.55 \end{aligned}$$

Quadrature axis:

$$0 = -Z_1 i_1 - \frac{L'_{11}}{G'_1} p \left[\frac{v_{do}}{n} \right] \quad \dots 3.56a$$

$$\text{or} \quad 0 = -G'_1 i_1 - \frac{L'_{11}}{Z_1} p \left[\frac{v_{do}}{n} \right] \quad \dots 3.56b$$

$$v_3 = -Z_3 i_3 - \frac{L'_{33}}{G'_3} p \left[\frac{v_{do}}{n} \right] \quad \dots 3.57a$$

$$\text{or} \quad \frac{v_3 G'_3}{Z_3} = -G'_3 i_3 - \frac{L'_{33}}{Z_3} p \left[\frac{v_{do}}{n} \right] \quad \dots 3.57b$$

$$v_q - v_{qo} = -Z_q i_q - \frac{L'_{qq}}{G'_q} p \left[\frac{v_{do}}{n} \right] \quad \dots 3.58a$$

$$\text{or} \quad \frac{v_q - v_{qo}}{Z_q} G'_q = -G'_q i_q - \frac{L'_{qq}}{Z_q} p \left[\frac{v_{do}}{n} \right]$$

$$v_5 = -Z_5 i_5 - \frac{L'_{55}}{G'_5} p \left[\frac{v_{do}}{n} \right] \quad \dots 3.59a$$

$$\text{or} \quad \frac{v_5 G'_5}{Z_5} = -G'_5 i_5 - \frac{L'_{55}}{Z_5} p \left[\frac{v_{do}}{n} \right] \quad \dots 3.59b$$

Adding equations 3.56b through 3.59b,

$$\begin{aligned} & \frac{v_3 G'_3}{Z_3} + \frac{v_q - v_{qo}}{Z_q} G'_q + \frac{v_5 G'_5}{Z_5} \\ &= - (G'_1 i_1 + G'_3 i_3 + G'_q i_q + G'_5 i_5) \\ & \quad - \left[\frac{L'_{11}}{Z_1} + \frac{L'_{33}}{Z_3} + \frac{L'_{qq}}{Z_q} + \frac{L'_{55}}{Z_5} \right] p \left[\frac{v_{do}}{n} \right] \\ &= -s_q^{-1} \left[\frac{v_{do}}{n} \right] - \left[\frac{L'_{11}}{Z_1} + \frac{L'_{33}}{Z_3} + \frac{L'_{qq}}{Z_q} + \frac{L'_{55}}{Z_5} \right] p \left[\frac{v_{do}}{n} \right] \quad \dots 3.60 \end{aligned}$$

123360

UNIVERSITY OF WINDSOR LIBRARY

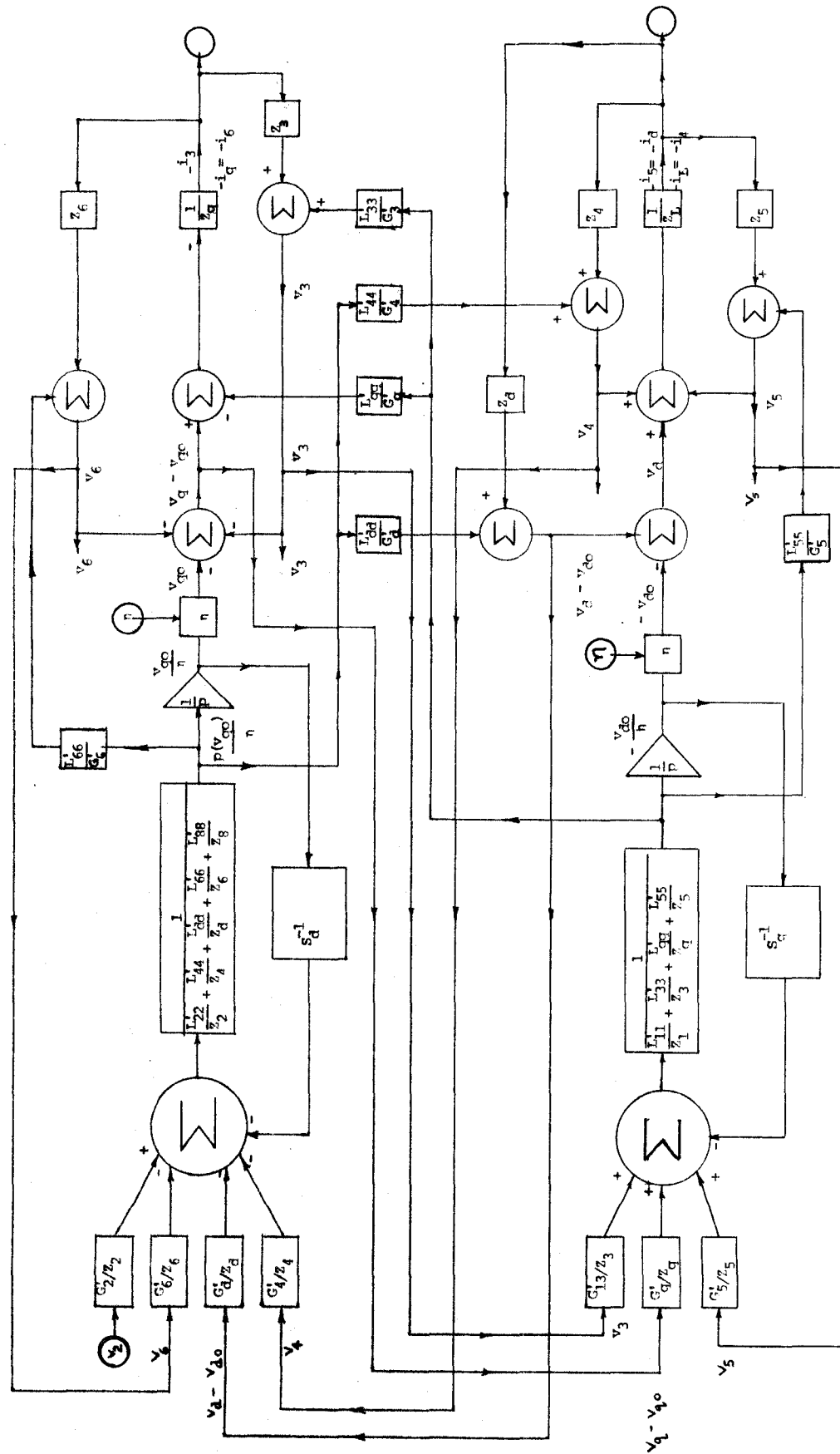

Fig. 3.3 Analogous Representation of a discrete-time

Thus with the help of equations 3.50 through 3.60, Fig. 3.3 shows the Analogue representation for the Metadyne. The effect of saturation on both the axes is considered in this representation. It contains two integrators only, and the non-linear portions in the feedback paths can be implemented with function generators.

Amplidyne

As stated earlier, the Amplidyne is a special type of Metadyne in which compensating windings provide complete compensation in both the axes. This results in a circuit without feedback. Thus in the absence of feedback, the machine will be stable, contrary to the Metadyne, which may be unstable. Therefore, damping windings are not required for the Amplidyne. From the experiments conducted by Fegley², it is observed that the effect of the eddy current circuit is negligible and thus the fictitious short-circuit winding representing eddy currents can be neglected. Therefore, the Amplidyne windings 5, 6, 1 and 8 can be omitted and the following relations apply:

Direct Axis:

$$v_2 = Z_2 i_2 + pL_{22} i_2 = (R_2 + pL_2) i_2 \quad \dots 3.61$$

$$v_4 = -pM_{24} i_2 - pL_{44} i_4 - pM_{d4} i_d - Z_4 i_4 \quad \dots 3.62$$

$$v_d = -pM_{2d} i_2 - pM_{4d} i_4 - pL_{dd} i_d + (G_3 i_3 + G_q i_q) \eta - Z_d i_d \quad \dots 3.63$$

$$v_4 + v_d + v_L = 0$$

$$\text{or } 0 = -pM_{24} i_2 - pM_{2d} i_2 - pL_{44} i_4 - pM_{4d} i_4 - pM_{d4} i_d - pL_{dd} i_d \\ - Z_4 i_4 - Z_d i_d - (G_3 + G_q) i_q \eta + v_L$$

$$\text{or } (Z_4 + Z_d + Z_L) i_d = - (G_3 + G_q) i_q$$

$$\text{or } i_d = - \frac{(G_3 + G_q) \eta i_q}{z_4 + z_d + z_L} \quad \dots 3.64$$

Quadrature axis:

$$v_3 = -pL_3 i_3 - pM_{3q} i_q - R_3 i_3 \quad \dots 3.65$$

$$v_q = - (G_2 i_2 + G_4 i_4 + G_d i_d) \eta - pM_{q3} i_3 - pL_q i_q - i_q R_q \quad \dots 3.66$$

$$\begin{aligned} 0 &= v_3 + v_q \\ &= -pL_3 i_3 - pM_{3q} i_q - R_3 i_3 - pM_{q3} i_3 - pL_q i_q - i_q R_q - G_2 i_2 \eta \\ 0 &= - (R_3 + R_q + pL_3 + pL_q) i_q - G_2 i_2 \eta \quad \dots 3.67 \end{aligned}$$

Therefore, from equations 3.61, 3.64 and 3.67, an Analogue Representation of Amplidyne can be drawn as shown in Fig. 3.4.

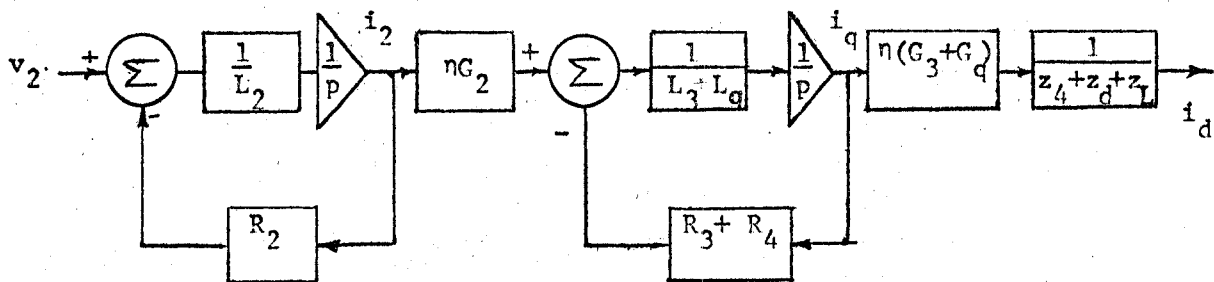

Fig. 3.4. Analogue Representation of Amplidyne

Normally the magnetic circuit is not saturated, so the effect of saturation is not shown in the Analogue representation, but if required, it can be shown as discussed in Chapter II.

3.3 Experimental Work

Among the many applications of the Amplidyne as a rotating amplifier, it is commonly used for voltage regulation, speed control, position control etc. An experiment has been performed where the amplidyne has been used in a position control system. The system used is shown below:

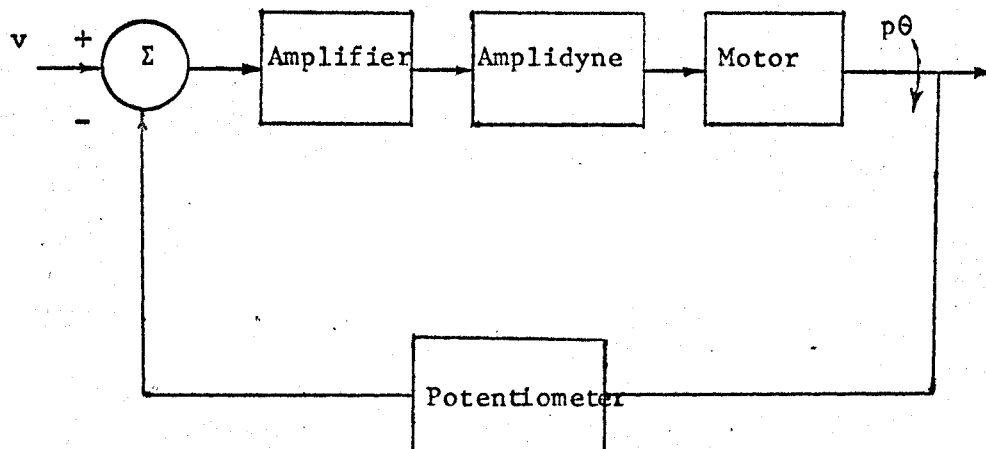

Fig. 3.5. Block Diagram for Position Control System

The components of the system are:

- 1) Amplifier - Working on the linear portion
- 2) Amplidyne - Without winding No.3
- 3) D.C. Motor - Separately excited
- 4) Potentiometer - With reduction gears

The system can be described by the following relations:

The Amplifier is working on the linear portion and the time constant of the field winding connected to the output of amplifier is negligible. Thus the amplifier with field winding gives 6.2 mA/volt as a constant transfer function.

Amplidyne:-

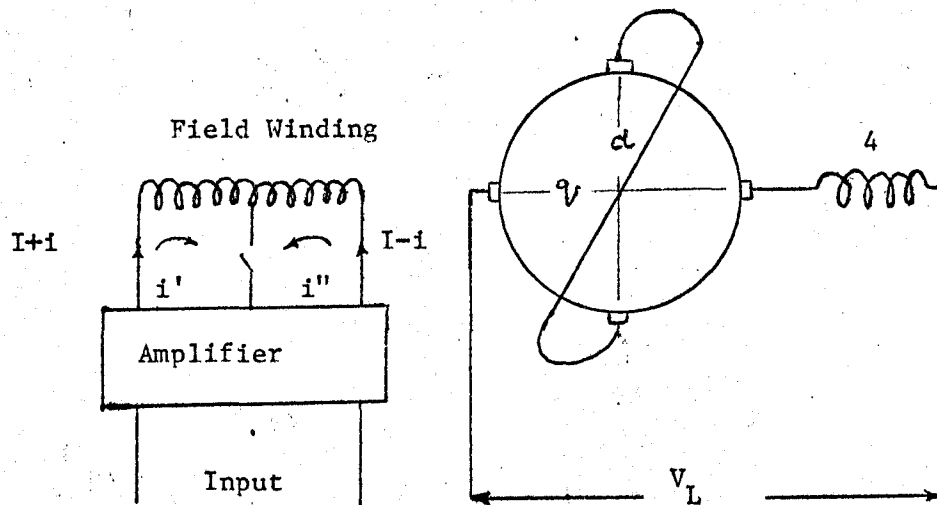

Fig. 3.6. Amplidyne

I - Direct current in the field winding when amplifier is balanced.

i - Signal current (alternating current in this case, because input to the system is sinusoidal).

In this type of field connection, the flux-linkage with d-axis winding is found.

$$\psi_d = -L_d i_d + M_{df} i' - M_{df} i'' + M_4 i_4$$

$$i' = I + i \quad i'' = I - i$$

$$\psi_d = -L_d i_d + M_{df} 2i + M_4 i_4 \quad \dots 3.68$$

Thus the equivalent field current is $2i$. i.e. $i_2 = 2i$.

$$i_2 = 2 K_A (v - K_p \theta) \quad \dots 3.69$$

$$v_d = -\eta G_q i_q \quad \dots 3.70$$

$$0 = -\left(R_q + pL_q\right) i_q - \eta G_2 i_2 \quad \dots 3.71$$

In the direct axis circuit, the resistance and inductance are taken in series with the armature of D.C. motor.

$$\begin{aligned} v_d &= \left(R_d + R_4 + R_m + pL_d + pL_4 + pL_m\right) i_d + v_b \\ &= (R + pL) i_d + v_b \end{aligned} \quad \dots 3.72$$

$$v_b = K_b p\theta \quad \dots 3.73$$

$$k_b i_d = J p^2 \theta + \alpha p\theta \quad \dots 3.74$$

$$v = V_m \sin \omega t \quad \text{input signal to the system} \quad \dots 3.75$$

Taking the Laplace Transformation for both sides and solving the equations 3.69 through 3.75 for θ ,

$$K_b K \frac{V_m \omega}{s^2 + \omega^2} = as^4 + bs^3 + cs^2 + ds + e) \theta (s) \quad \dots 3.76$$

where $K = (\eta G_q) (\eta G_2) 2K_A$

$$a = J L L_q$$

$$b = \alpha L L_q + R J L_q + J L R_q$$

..3.77

$$c = R R_q J + \alpha L R_q + R \alpha L_q + K_b^2 L_q$$

$$d = R R_q \alpha + K_b^2 R_q$$

$$e = K K_p K_b$$

The output of the system, i.e. the angular position θ , is found in the time domain by taking the inverse Laplace transformation of the equation 3.76.

The constants of the system components were found experimentally and are listed below:

Amplifier: $K_A = 6.2 \text{ mA/volt}$

Amplidyne: $R_d = R_q = 25.4 \text{ ohms}$ $L_d = L_q = 0.765 \text{ H}$

$$(\eta G_q) (\eta G_2) = 343 \times 10^3$$

Motor: $R_m = 24.2 \text{ ohms}$, $K_b = 0.58 \text{ volt sec./rad.}$

$$J = 1.66 \times 10^{-4} \text{ Kgm. metre}^2, \alpha = 4.54 \times 10^{-4}$$

$$\text{Nw. metre. sec/rad.}$$

Potentiometer: $K_p = 0.0198 \text{ volts per radian}$

Input Voltage: 0.27 v at $f = 0.1 \text{ c/s}$ peak

These constants are substituted in the equations 3.76 and 3.77 and

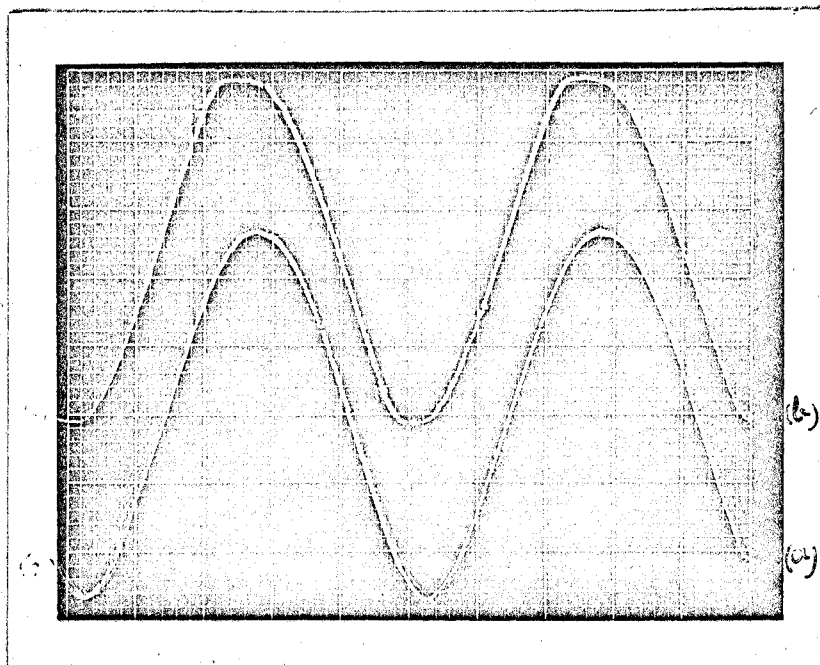

Fig. 3.7(a) Experiment curves.

(a) Input vs time

(b) Output vs time

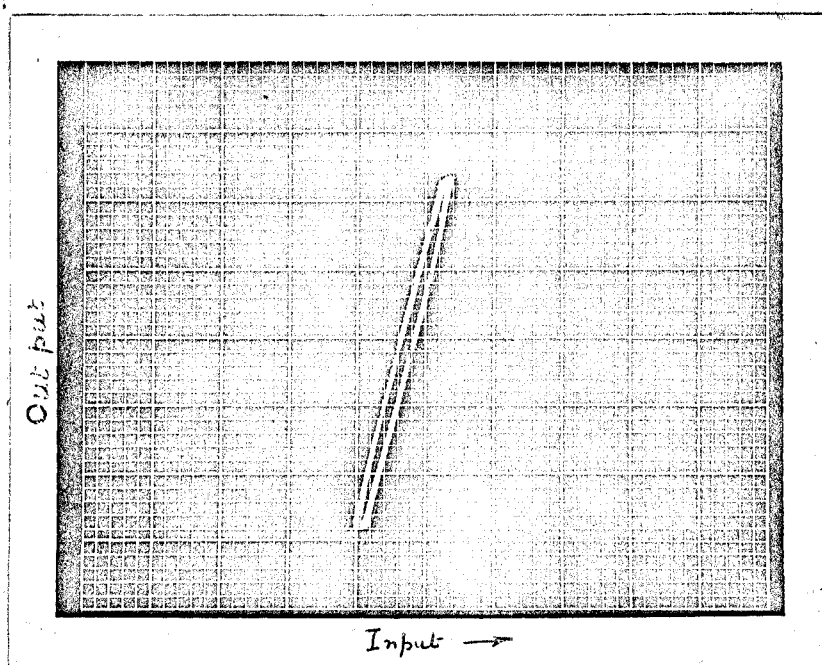

Fig. 3.7(b) Experiment curve

Input vs output

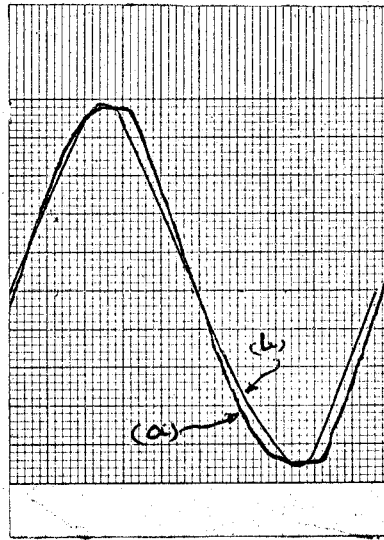

Fig. 3.7(c) Output vs time

(a) Experimental

(b) Theoretical

$\theta(t)$ is calculated. $\theta(t)$ in terms of the voltage is plotted against time and compared with the experimental results in Fig. 3.7. From the experimental results, it is observed that the output curve is flat topped, while in the theoretical results, it is sinusoidal, but the difference between the results is only 5 - 6% maximum.

A curve between input and output is traced experimentally on the CRO, and it appears like a hysteresis loop. It is found that the area of loop increases with the increase of frequency of the supply.

CHAPTER IV

A.C. COMMUTATING MACHINES

Though D.C. commutating machines were developed earlier and have been commonly used, later A.C. commutating machines were developed and used especially in traction and domestic appliances. A.C. commutating motors have two advantages over the other A.C. motors: (i) its high starting torque and (ii) its variable speed. These can be single-phase and three-phase motors. Three-phase motors are used in traction while single-phase motors are most commonly used in the domestic appliances. The A.C. series motor is commonly known as a 'Universal Motor'.

Series Motor

If instead of a D.C. supply, an A.C. supply is applied across the terminals of a D.C. series motor, the motor will run, because the direction of both flux and armature current changes simultaneously. But it is observed that with the A.C. supply, the performance is poor - less torque and poor power factor. The performance can be improved by reducing the inductance of the windings. The field inductance can be reduced by decreasing the number of turns on the field winding which results in less flux and thus less torque. To get the same torque, the number of armature turns is required to be increased. In this way, the armature inductance is increased. A compensating winding can be provided on the q-axis which produces an m.m.f. opposite to that of the armature, and thus reduces the effective inductance. Therefore, the performance will improve, i.e. better speed regulation, more torque and better power factor.

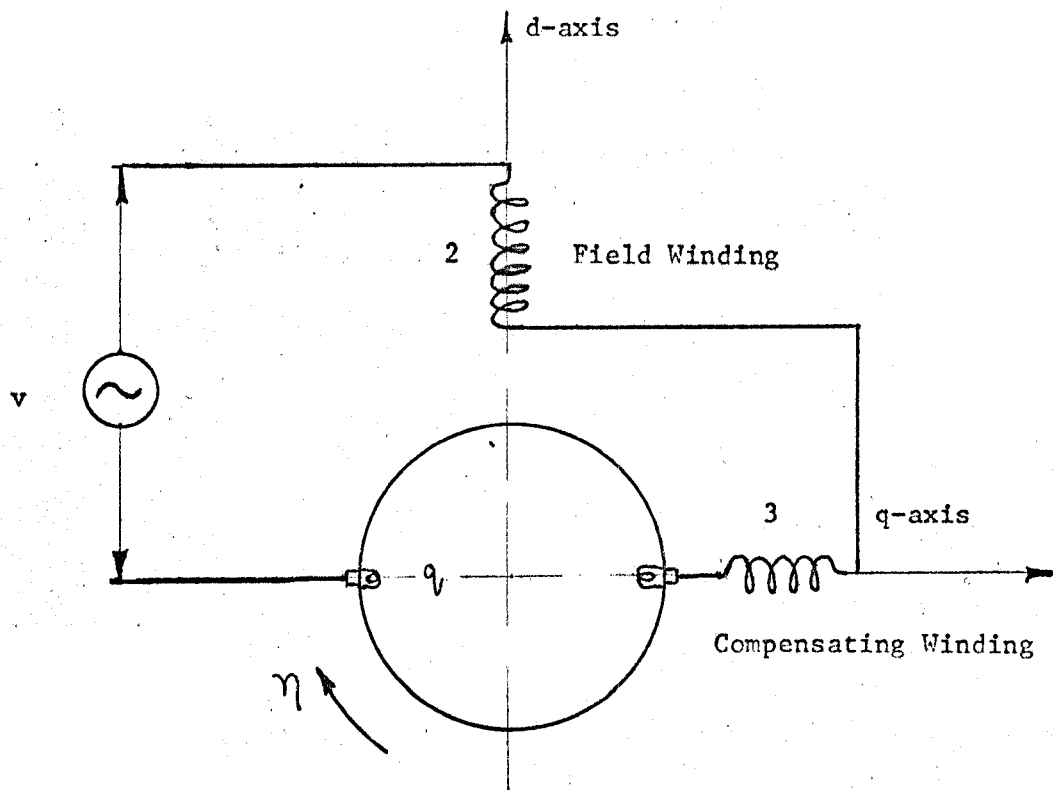

Fig. 4.1. Schematic diagram of Series Motor

The A.C. series motor is shown in Fig. 4.1. The voltage equations are given below:

$$v_2 = -pL_2 i_2 - i_2 r_2 \quad \dots 4.1$$

$$v_3 = -pM_{3q} i_q - pL_3 i_3 - i_3 r_3 \quad \dots 4.2$$

$$v_q = -pM_{q3} i_3 - pL_q i_q - i_q r_q + G_2 i_2 \eta \quad \dots 4.3$$

$$T = Jp\eta + \alpha\eta - i_q G_2 i_2 \quad \dots 4.4$$

$$i_2 = i_3 = i_q = i \quad \dots 4.5$$

$$-v = v_2 + v_3 + v_q \quad \dots 4.6$$

Substituting the equations 4.1, 4.2, 4.3 and 4.5 in equation 4.6, it is obtained,

$$v = p(L_2 + L_3 + L_q + 2M_{q3})i + (r_2 + r_3 + r_q)i - G_2 \eta i \quad \dots 4.7$$

With the help of these equations, an Analogue representation can be drawn in Fig. 4.2 for an A.C. Series motor.

Equivalent circuit:

Referring to equation 4.7, which gives the performance equation of series motor, an equivalent circuit can be drawn as shown in Fig. 4.3.

Steady State Analysis:

Let the voltage applied to the motor as $v = V_m \sin \omega t$, and the current be $i = I_m \sin (\omega t + \phi)$

for steady state, the equations 4.4 and 4.7 are modified as

$$V = (r_2 + r_3 + r_q) I - G_2 \eta I + j (L_2 + L_3 + L_q + 2M_{q3}) \quad \dots 4.8$$

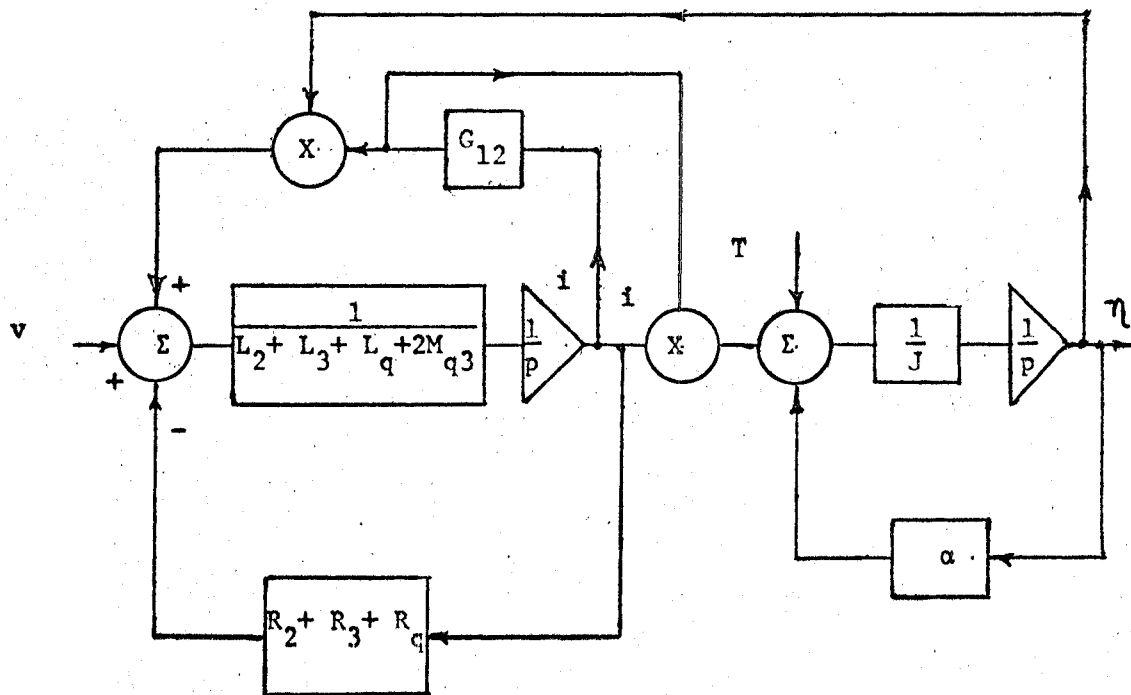

Fig. 4.2 Analogue Representation of Series Motor

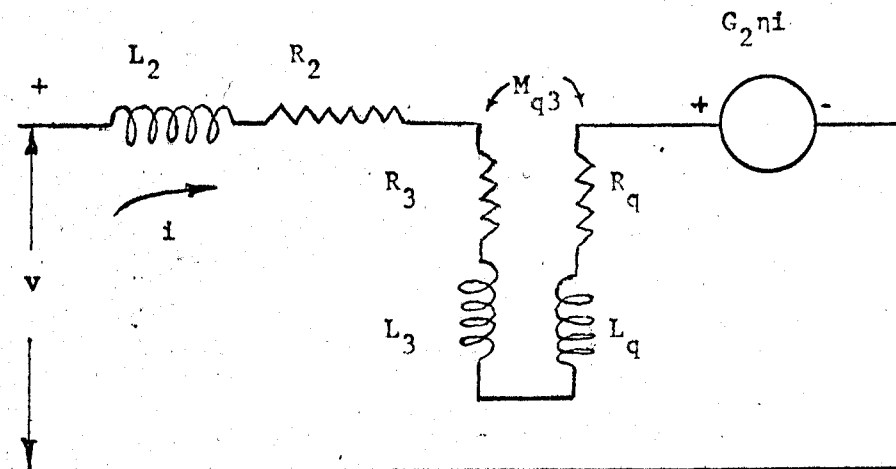

Fig. 4.3 Equivalent Circuit of Series Motor

$$\text{The Electrical Torque developed } T_e = G_2 I_m^2 \sin^2 (\omega t + \phi), \quad \dots 4.9$$

$$\text{and the average torque } T_{av} = \frac{1}{2} G_2 I_m^2 \quad \dots 4.10$$

Repulsion Motor:

Another type of single phase A.C. commutating machine is the Repulsion Motor. In this machine, the brushes on the commutator are short circuited. The brush axis makes an angle with the field axis [neither 90° nor zero degree]. The field winding is supplied with A.C. voltage. The m.m.f. produced in the air-gap induces e.m.f. in the armature winding. Thus the current in the short circuited armature winding reacts with the air-gap field and produces torque. The amount of voltage induced in the armature depends upon the angle between the two axes. The rotation of the armature is in the direction of the brush-axis shift.

A schematic diagram of the Repulsion Motor is given in Fig. 4.4.

In the figure shown, the brush axis makes an angle γ with the pole axis and this angle is independent of time i.e. $\frac{d\gamma}{dt} = 0$. The short circuited coils undergoing commutation produce a field which is perpendicular to the brush axis. The relationships of the flux linkage and the voltage induced in the windings are given below.

$$\psi_1 = L_1 i_1 + M_{12} i_2 \cos \gamma + M_{13} i_3 \cos (90 + \gamma) \quad \dots 4.11$$

$$\psi_2 = M_{12} i_1 \cos \gamma + L_2 i_2 \quad \dots 4.12$$

$$\psi_3 = M_{13} i_1 \cos (90 + \gamma) + L_3 i_3 \quad \dots 4.13$$

$$v_1 = p\psi_1 + i_1 r_1 \quad \dots 4.14$$

$$v_2 = 0 = -p\psi_2 - i_2 r_2 - \eta G_{12} i_1 \sin \gamma - \eta G_{32} i_3 \quad \dots 4.15$$

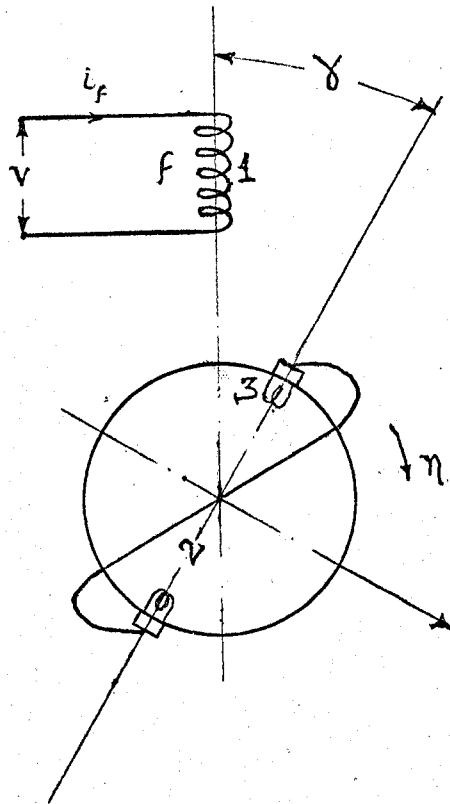

Fig. 4.4. A Schematic Diagram of Repulsion Motor

$$v_3 = 0 = -p\psi_3 - i_3 r_3 - \eta G_{13} i_1 \cos \gamma - \eta G_{32} i_2 \quad \dots 4.16$$

Analogue Representation:

The equations 4.11 through 4.16 are manipulated and rewritten to facilitate the Analogue Representation of Repulsion Motor.

$$i_1 = \frac{\psi_1 - \psi_2 + \psi_3}{L_1 + L_2 \cos^2 \gamma + L_3 \sin^2 \gamma - 2L_2} = \frac{\psi}{L} \quad \dots 4.17$$

$$i_2 = \frac{\psi_2}{L_2} + \frac{\psi}{L} \cos \gamma \quad \dots 4.18$$

$$i_3 = \frac{\psi_3}{L_3} - \frac{\psi}{L} \sin \gamma \quad \dots 4.19$$

$$v_1 = v = p\psi_1 + \frac{\psi}{L} r_1 \quad \dots 4.20$$

$$0 = -p\psi_2 - \frac{\psi_2}{L_2} r_2 - \frac{\psi}{L} r_2 \cos \gamma - \eta (G_{12} + G_{32}) \frac{\psi}{L} \sin \gamma - \eta G_{32} \frac{\psi_3}{L_3}$$

or

$$p\psi_2 = -\frac{\psi_2}{L_2} r_2 - \frac{\psi}{L} r_2 \cos \gamma - \eta \left(G_2 \frac{\psi}{L} \sin \gamma + G_{32} \frac{\psi_3}{L_3} \right) \quad \dots 4.21$$

$$0 = -p\psi_3 - \frac{\psi_3}{L_3} r_3 - \frac{\psi}{L} r_3 \sin \gamma - \eta (G_{13} + G_{23}) \frac{\psi}{L} \cos \gamma - \eta G_{32} \frac{\psi_2}{L_2}$$

or

$$p\psi_3 = -\frac{\psi_3}{L_3} r_3 - \frac{\psi}{L} r_3 \sin \gamma - \eta \left(G_3 \frac{\psi}{L} \cos \gamma + G_{32} \frac{\psi_2}{L_2} \right) \quad \dots 4.22$$

$$T = Jp\eta + a\eta + i_2 G_{12} i_1 \sin \gamma - i_3 G_{13} i_1 \cos \gamma \quad \dots 4.23$$

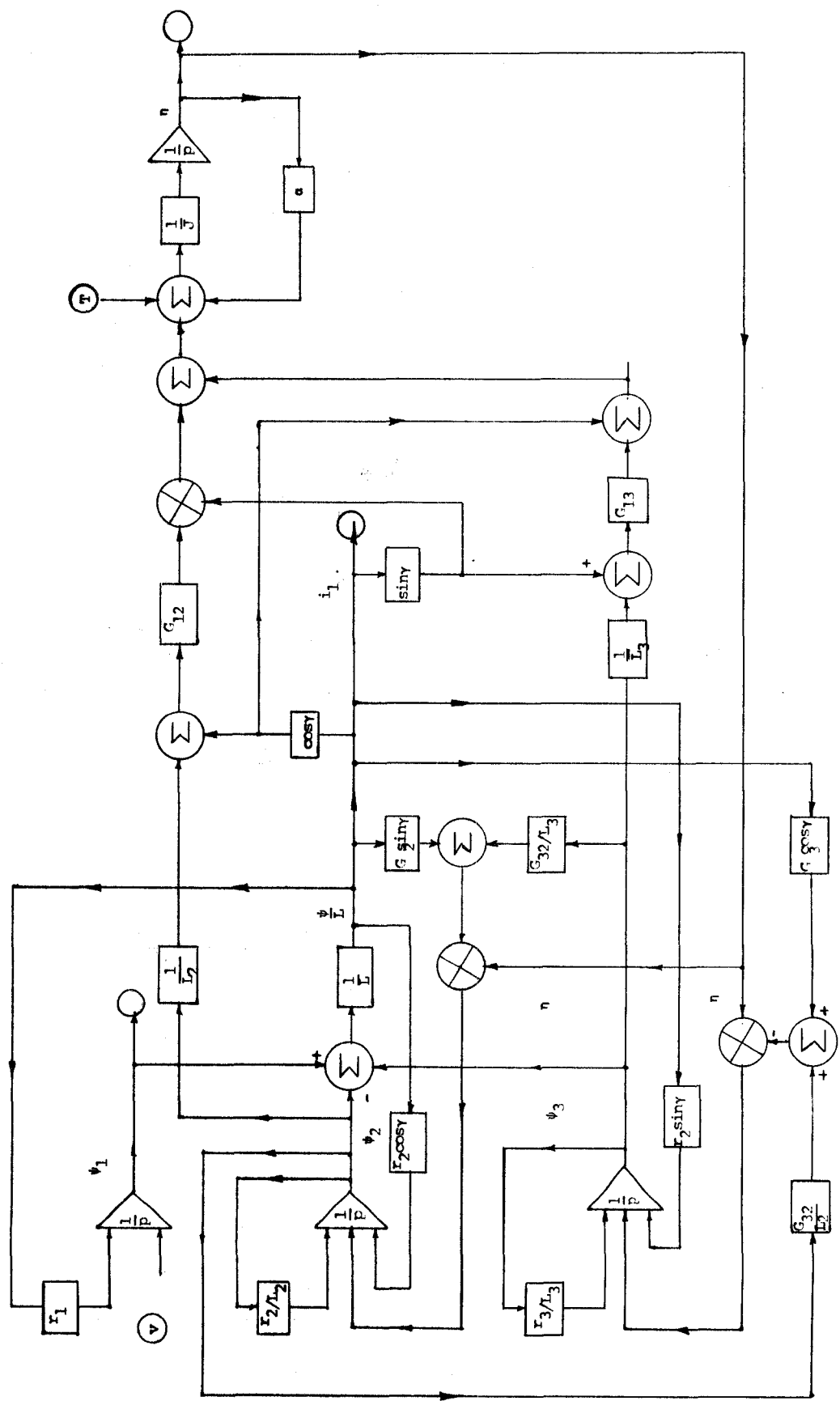

Fig. 4.5. Analogue Representation of Repulsion Motor

In the derivation of the above equations, following assumptions are made:

$$1) \quad \frac{l_2}{L_2} \ll 1, \quad \frac{l_3}{L_3} \ll 1$$

$$2) \quad l_2 = l_3$$

With the help of equations 4.20 through 4.23, an Analogue Representation is drawn in Fig. 4.5. In this representation four integrator, two multipliers and potentiometers are required. No trigonometrical function generator is required because the performance is shown for the fixed angle γ .

Steady State Analysis:

The equations 4.14 through 4.16 are solved for the steady-state analysis of the machine. The voltage applied to the field is $v = V_m \cos \omega t$ and assuming the currents $i_1 = I_{m1} \cos (\omega t + \phi)$

$$i_2 = I_{m2} \cos (\omega t + \phi)$$

$$i_3 = I_{m3} \cos (\omega t + \xi)$$

Hence, substituting these values in equations 4.11 through 4.16 for steady state solution:

$$V = j\omega L_1 I_1 + j\omega M_{12} I_2 \cos \gamma - j\omega M_{13} I_3 \sin \gamma + I_1 r_1 \quad \dots 4.24$$

$$0 = -j\omega M_{12} I_1 \cos \gamma - j\omega L_2 I_2 - I_2 r_2 - n G_{12} I_1 \sin \gamma - n G_{32} I_3 \quad \dots 4.25$$

$$0 = +j\omega M_{13} I_1 \sin \gamma - j\omega L_3 I_3 - I_3 r_3 - n G_{13} I_1 \cos \gamma - n G_{32} I_2 \quad \dots 4.26$$

Solving these three equations, values of I_1 , I_2 and I_3 are found out.

$$I_1 = \frac{v[r_2 r_3 - \omega^2 L_2 L_3 - \eta^2 G_{32}^2 + j\omega(r_2 L_3 + r_3 L_2)]}{D} \quad \dots 4.27$$

$$I_2 = \frac{+v[+\omega^2 M_{13}^2 \sin^2 \gamma + r_3 \eta G_{12} \sin \gamma - \omega^2 L_3 M_{12} \cos \gamma + j(\omega M_{13} \eta G_{13} \sin \gamma \cos \gamma + \omega L_3 \eta G_{12} \sin \gamma - \omega M_{12} r_3 \cos \gamma)]}{D} \quad \dots 4.28$$

$$I_3 = \frac{v[(\eta^2 G_{12} G_{32} \sin \gamma - r_2 \eta G_{13} \cos \gamma - \omega^2 L_2 M_{13} \sin \gamma) + j(\omega M_{12} \eta G_{32} \cos \gamma - \omega L_2 \eta G_{13} \cos \gamma + \omega M_{13} r_2 \sin \gamma)]}{D} \quad \dots 4.29$$

where

$$\begin{aligned} D = & (r_1 + j\omega L_2)(r_2 + j\omega L_2)(r_3 + j\omega L_3) - \eta^2 G_{32}^2 (r_1 + j\omega L_1) \\ & + (r_3 + j\omega L_3)j\omega M_{12} \cos \gamma (\eta G_{12} \sin \gamma + j\omega M_{12} \cos \gamma) \\ & - 2\omega^2 M_{12} M_{13} \eta G_{32} \sin \gamma \cos \gamma - \eta G_{32} j\omega M_{12} G_{13} \cos^2 \gamma \\ & + j\omega \eta^2 G_{32} G_{12} M_{13} \sin^2 \gamma + (r_2 + j\omega L_2) j\omega M_{13} \sin \gamma (\eta G_{13} \cos \gamma - j\omega M_{13} \sin \gamma) \end{aligned} \quad \dots 4.30$$

The equations for torque will be

$$\begin{aligned} T_e = & G_{12} I_{m1} I_{m2} \sin \gamma \sin(\omega t + \theta) \sin(\omega t + \phi) \\ & - G_{13} I_m I_{3m} \cos \gamma \sin(\omega t + \theta) \sin(\omega t + \phi) \end{aligned} \quad \dots 4.31$$

CHAPTER V

CONCLUSION

In the present study, a rigorous mathematical presentation of a most general D.C. machine, the Metadyne has been presented. All the possible difficulties encountered in the analysis of commutating machines have been overcome. The Analogue computer representation has been formulated. No attempt has been made to check the Analogue representation on the actual Analogue computer, because of the non-availability of such a computer in our Laboratories. But it is expected the constants of the machine will produce scaling difficulties in the representation. It is suggested that these difficulties can be overcome by taking the constants on a per unit basis where the rated voltage and rated current are taken as base values. The inverse saturation curves can be simulated by function generators.

The D.C. commutating machines have been used in a position control system. The results have been verified with an error of 5-6% with a sinusoidal input to the system.

Finally, the single phase A.C. series motor and the Repulsion Motor have been studied and their Analogue Computer representations have been presented.

REFERENCES

1. West, H.R. - The Cross Field Theory of Alternating Current Machines, A.I.E.E. Trans., Vol.45; Feb.1926, Pp.466-474.
2. Fegley, K.A. - Metadyne Transients, A.I.E.E. Trans., Vol.74, Pt.III, Dec. 1955, Pp.1179-1188.
3. Barton, T.H. & Jones, C.V. - A Practical Commutator Primitive for Generalized Machine Theory, A.I.E.E. Trans., Vol.79, Pt.III, June 1960, Pp.227-281.
4. Hwang, H.H. - Application of General Equations of Induced Voltage and Armature Reaction. Part I. Performance of an Induction Machine. C.P.61-1030.
5. Hwang, H.H. - Application of General Equations of Induced Voltage and Armature Reaction. Part II. Performance of A Synchronous Machine. C.P.63-1004.
6. Yu, Yao-nau - The Impedance Matrix and Analysis of Commutator Machines, I.E.E.E. Trans., Paper No.31 TP 65-61.
7. Jordon, H.E. - Analysis of Induction Machines in Dynamic Systems, I.E.E.E. Trans., Paper No. 31 TP 65-109.
8. Saunders, R.M.- Measurement of D.C. Machine Parameters, A.I.E.E. Trans. Vol.70, 1951, Pp.700-706.
9. White and Woodson - Electromechanical Energy Conversion (Book), John Wiley & Sons, Inc., New York 1959.
10. Thaler, G.J. & Brown, R.G. - Analysis and Design of Feedback Control Systems (Book), McGraw-Hill, 1960.

VITA AUCTORIS

- 1938 Born on February 28, in Thatta, India.
- 1955 Completed InterScience at G.N.K. College, Kaupur.
- 1959 Graduated from Birla Engineering College, Pilani, India, with the degree of B.E. in Electrical Engineering.
- 1960 Graduated from University of Roorkee, Roorkee, with the degree of M.E. in Electrical Machine Design.
- 1965 Candidate for the degree of M.A.Sc. in Electrical Engineering at the University of Windsor, Windsor, Ontario.