

12-19-2003

# Swine Waste Demonstration and Training Project

C. V. Maxwell

*University of Arkansas, Fayetteville*

K. VanDevender

K. P. Coffey

P. A. Moore

I. Chaubey

*See next page for additional authors*

Follow this and additional works at: <http://scholarworks.uark.edu/awrctr>

 Part of the [Agriculture Commons](#), [Fresh Water Studies Commons](#), and the [Water Resource Management Commons](#)

---

## Recommended Citation

Maxwell, C. V.; VanDevender, K.; Coffey, K. P.; Moore, P. A.; Chaubey, I.; and Smith, D. R.. 2003. Swine Waste Demonstration and Training Project. Arkansas Water Resources Center, Fayetteville, AR. MSC314. 53

This Technical Report is brought to you for free and open access by the Arkansas Water Resources Center at ScholarWorks@UARK. It has been accepted for inclusion in Technical Reports by an authorized administrator of ScholarWorks@UARK. For more information, please contact [scholar@uark.edu](mailto:scholar@uark.edu), [ccmiddle@uark.edu](mailto:ccmiddle@uark.edu).

---

**Authors**

C. V. Maxwell, K. VanDevender, K. P. Coffey, P. A. Moore, I. Chaubey, and D. R. Smith



# Arkansas Water Resources Center

## Swine Waste Demonstration and Training Project University of Arkansas, Division of Agriculture

**MSC-314**

Final Report

December 2003

**Principal Investigators:**

C. V. Maxwell<sup>1</sup>, K. VanDevender, K. P. Coffey, P. A. Moore, I. Chaubey and D. R. Smith

Arkansas Water Resources Center  
112 Ozark Hall  
University of Arkansas  
Fayetteville, Arkansas 72701

---

<sup>1</sup> Corresponding Author. University of Arkansas, AFLS B-106-A Animal Science Department, Fayetteville, AR 72701. Phone 479-575-2111. Fax 479-575-7294.

**Project 900**

**Swine Waste Demonstration and Training Project  
University of Arkansas, Division of Agriculture**

**FY 1998, CWA Section 319(h)**

Final Report 12-19-03

**Principal Investigators**

C. V. Maxwell<sup>2</sup>, K. VanDevender, K. P. Coffey, P. A. Moore, I. Chaubey and D. R. Smith

---

<sup>2</sup> Corresponding Author. University of Arkansas, AFLS B-106-A Animal Science Department, Fayetteville, AR 72701. Phone 479-575-2111. Fax 479-575-7294.

**Project 900**  
**Swine Waste Demonstration and Training Project**  
**University of Arkansas, Division of Agriculture**  
**FY 1998, CWA Section 319(h)**

Final Report 12-19-03

**Principal Investigators**

C. V. Maxwell<sup>3</sup>, K. VanDevender, K. P. Coffey, P. A. Moore, I. Chaubey and D. R. Smith

**Problem/Need Statement Project**

The Arkansas Water Quality Inventory Report for 1994 lists the expansion of confined animal production as a special state concern. Of the nearly 90,000 Arkansas stream miles (e.g., perennial streams, intermittent streams, ditches, etc.) about ten percent were assessed through monitoring and comparative evaluation in compiling the report. A review of the report indicates that in the areas of animal production, the reduced water quality attributed to agriculture is primarily due to elevated nutrient and pathogen concentrations. The report also mentions an increased incidence of high nitrate concentration in wells and springs in areas of concentrated animal operations. In northwest Arkansas five to seven percent of domestic wells have nitrate levels in excess of those recommended by the Safe Drinking Water Act.

Modern swine rearing facilities often have large numbers of animals and a relatively limited land base for manure application. Disposal of the concentrated animal waste, which accumulates in efficient production systems, in a manner that minimizes odor and optimizes nutrient utilization is an increasing problem facing the swine industry. Animal waste can be a valuable resource as an alternative source of fertilizer nitrogen (N), phosphorus (P), and potassium (K) in maintaining and restoring soil productivity. In fact, by improving ground cover, runoff volume and erosion may also be reduced. Conversely, application of animal manure at rates greater than a crop can utilize has been shown to result in nitrate (NO<sub>3</sub>) movement through the soil into ground water and can result in an excessive rise in soil test P levels leading to increased phosphorus runoff. This can be a problem, since phosphorus is normally the limiting nutrient for eutrophication in freshwater systems. Odor and nutrient problems can both be exacerbated by excessive nutrient buildup in lagoons/holding ponds that have not been dewatered in a timely manner.

Arkansas was the twelfth highest swine producing state in the nation at the initiation of this project. Of the 2 million swine produced annually, the vast majority are raised on farms with liquid waste handling systems. On these farms, the animals are housed in total confinement facilities where the manure is handled with the addition of supplemental water. Water is typically used to flush the manure from the house into storage/treatment basins until it is land

---

<sup>3</sup> Corresponding Author. University of Arkansas, AFLS B-106-A Animal Science Department, Fayetteville, AR 72701. Phone 479-575-2111. Fax 479-575-7294.

applied to supply the nutrient (nitrogen) needs of a forage crop. While this approach has the advantages of production economics, animal health, beneficial use of the manure for crops, and environmental preservation (with proper management), there are a couple points of concern.

### Soil Phosphorus Concerns

The first concern in swine manure management is related to the phosphorus content of the manure. Typically the manure is applied based on the receiving crop's nitrogen requirements. Under these application rates, more phosphorus is applied than the crop will normally utilize (around five fold), thereby resulting in a phosphorus buildup in the soil. The phosphorus content of surface soil directly influences the loss of phosphorus in runoff (Daniel et al., 1994), which can reduce surface water quality. Runoff losses from manure are a particular concern in regions where confined animal operations exist in proximity to surface water bodies sensitive to phosphorus inputs (Daniel et al., 1994). Because of this concern, some states have established subjective threshold soil phosphorus levels intended to ensure continued crop production while not producing eutrophic runoff.

While phosphorus-based application rates would in theory reduce this risk, they would also greatly increase the required land application area, and require the purchase of commercial nitrogen and potassium fertilizers to maintain forage production. Both results present problems. On many farms, the required additional acreage is not readily available. Continued operation would require transporting the manure to more distant application sites. The additional distance to the land application sites, if available, would increase the required time to apply the manure, which would increase the difficulty of proper manure management and the likelihood of point-source discharges from the ponds. Furthermore, the additional commercial fertilizer cost would lead to under fertilization of pasture land in many cases. The low fertility condition could potentially result in a reduction in ground cover and an increase in erosion.

A better approach to addressing soil phosphorus buildup concerns is to reduce the phosphorus levels in the manure. Doing so would still supply the crop's phosphorus needs, while reducing the amount of phosphorus available to potentially degrade surface water quality.

### Manure Solids Concerns

A second point of concern is the difficulty of handling manure solids that fall from suspension and settle during storage. The majority of swine manure is stored in holding ponds that may be preceded by settling basins. The holding ponds are earthen storage structures that are designed to hold 120 to 180 days of manure between land applications. Settling basins are earthen basins designed so that 50 to 70 percent of the solids settle out as liquid manure flows though on their way from the animals to holding ponds or lagoons. Settling basins are typically designed to store 45 to 90 days of manure solids. There are some farms that store the liquid manure in concrete pits. All of these storage structures are designed for the manure to be agitated prior to land application so that both the solid and liquid fractions are removed.

There are some anaerobic treatment lagoons in the state. Lagoons, in contrast to pure storage structures, also have a biological treatment component. The treatment consists of the biological

decomposition of about 85% of the manure solids into primarily methane and carbon dioxide. The nitrogen in the organic matter is converted into the ammoniacal forms. In Arkansas, lagoons are designed to have a liquid storage volume of 180 days and an undigested solids (about 15 percent of total solids) storage volume of five or more years. With proper management, the lagoon is pumped down to the treatment volume every 180 days without agitation. The volume required for treatment and the accumulated solids are not removed. About every five years, the accumulated solids should be removed by dredging or agitation and pumping.

For all of these structures, if the solids are not removed they will build up over time and reduce storage capacity. The reduced capacity can greatly increase the required pumping frequency to maintain adequate freeboard in the storage structure. The increased pumping frequency often results in land applications on saturated soils or immediately prior to rainfall events. Situations that increase the potential for nutrient-laden runoff can negatively impact water quality. In severe cases, if a pump-down does not occur, overflows will cause point-source discharges. In addition the increased manure solids concentrations increase the potential for offensive odors.

Lack of education and proper equipment have contributed to holding ponds and settling basins being managed as lagoons with only water being pumped, thereby leaving the solids to accumulate. This has resulted in a significant portion of the settling basins and holding ponds in Arkansas to have significant amounts of solids build up.

Demonstrating proper solids management by documenting nutrient and solids stratification and storage volume retention and the effect of agitation will provide the information necessary to present the benefits and promote the implementation of solids management.

### Shared Organizational Concerns and Cooperation

The concerns listed above are shared by many organizations. Among them are University of Arkansas Animal Science and Agronomy Departments, University of Arkansas Cooperative Extension Service, the Arkansas Department of Pollution Control and Ecology, the Arkansas Soil and Water Conservation Commission, the Natural Resources Conservation Service, the Arkansas Pork Producers Association, the Tyson Foods, Inc, Swine Division, and Cargill Pork. The shared concerns have resulted in a close working relationship that expresses itself in the annual environmental training that permitted swine producers attend, and an ongoing swine odor survey and management study.

One objective for the new Animal Science swine facility is to be a long term model of the proper management of a swine production unit in terms of animal nutrition, animal management, and manure and odor management. To this end, a new swine research/demonstration farm was constructed. This farm is a commercial-scale wean-to-finish operation that will meet or exceed Arkansas environmental regulations. The funds to build these new facilities are not being sought in this proposal. However, the new facilities will provide a location to demonstrate BMPs to address the concerns mentioned above.

The advantages of demonstrating some best management practices (BMPs) on a farm under university control are based on a few key points about the Arkansas swine industry. First, 90% or more of the swine in Arkansas are produced in a contract grower arrangement. Under this system the contract farmer owns the farm and the facilities, but the company integrator supplies the animals and feed. Decisions such as animal delivery and pickup dates and feed rations are under the integrator's control. Decisions such as manure management and land application of manure are made by the farmer.

This division of management responsibilities means that to demonstrate various BMPs different audiences have to be targeted. For example, to implement changes in animal feeds, the target audience would consist of the nutritionists employed by the integrators. In Arkansas this would be Tyson and Cargill as well as nutritionists who are employed by companies which market feed into Arkansas. To implement changes in manure application practices, the target audience would be the farmers.

Secondly, different audiences are receptive to different educational approaches and conditions. With integrator audiences, demonstrations based on side by side comparisons of the BMP implementation to non-implementation, under fairly tight management control are better received than demonstrations without the direct comparisons. With farmers, demonstrations without direct comparisons work well, if proper management assistance and documentation is provided. Examples of this are the very successful verification farms where rice and soybean production practices have been demonstrated. On the verification farms, the farmer agrees to follow the recommendations of the Extension personnel providing management expertise. The effectiveness of the practices are documented/demonstrated through the comparison of crop production under extension management and production in previous years and/or typical production.

As a result of the established shared concerns and working relationships between the Arkansas swine industry, the university system, and governmental organizations, the swine industry were active partners in this project and, therefore, are predisposed to implement BMPs demonstrated to be effective and affordable. This multidisciplinary effort should ensure a very high probability of success of this demonstration and serve to develop a formal relationship between the non-point program and the APPA.

### **General Project Description:**

There are several BMPs that can reduce phosphorus runoff and assure that ground water is not contaminated with nitrate from fields fertilized with swine manure. Approaches include decreasing the amount of phosphorus in the manure by decreasing the amount fed to swine or by improving dietary phosphorus availability. This can be done by reducing the unavailable dietary phosphorus by adding the microbial phytase enzyme to the feed to break down phytate-bound phosphorus in corn and soybean meal. Phytase is an enzyme which degrades phytate to release phosphorus and other nutrients. It catalyzes the hydrologic cleavage of the phosphoric acid esters of inositol. Thus, it liberates ortho-phosphates which can be absorbed by the animal. At the same time, trace minerals may be liberated as well and converted to an absorbable form. Numerous reports have shown that microbial phytase is very effective for improving the



availability of phytate phosphorus in typical swine diets (Nelson et al., 1968). Simons et al. (1990) found that the addition of phytase to corn-soybean-sunflower based diets increased phosphorus availability by 50% and decreased phosphorus excretion by 35%. Bruce and Sundstol (1995) found an average increase in ileal phosphorus digestibility of 23% in high fiber diets with the addition of phytase. Balance trials by Pierce et al. (1994) have quantified the reduction of phosphorus in excreta with values approaching 40%. Cromwell and Coffey (1991) estimated that the actual reduction in phosphorus excretion in an 80-kg pig fed low phosphorus diets with phytase was 6.2 g/day when compared to pigs fed typical industry phosphorus levels or 3.1 g/day when compared to pigs fed according to NRC requirements. This level of reduction would amount to as much as 217 to 434 g of phosphorus over a 70 day finishing period (50 to 109 kg), depending upon the current dietary inclusion levels.

Feeding microbial phytase in low phosphorus diets with levels as low as 300 phytase units per kilogram of diet (Knabe and Quinn, 1996) has also been shown to produce similar performance when compared to pigs fed a normal phosphorus-supplemented diet. In the finishing diet, phytase levels as low as 200 phytase units per kilogram of diet have been effective in replacing inorganic phosphorus supplements in swine diets.

Cost to supply phytase has been substantially reduced since the implementation of this project and with the development of more heat resistant sources of phytase, can be added to the feed prior to pelleting. Cost to supply phytase at 500 phytase units per kilogram of diet is \$1.36 per ton of feed. The cost savings in reduced dietary phosphorus (using a cost of defluorinated phosphate of \$340 per ton) is \$1.87 per ton of feed. Therefore, the application of this technology has the potential of both slightly reducing dietary costs (by \$0.03 per ton of feed with inclusion levels of 500 phytase units per kilogram of feed when all dietary ingredient changes are considered) and reducing the cost of manure spreading in areas where high soil phosphorus levels dictate the need for a larger land application area. Movement to a phosphorus-based waste management plan and the increased costs associated with manure application would make the use of phytase technology even more appealing.

The University of Arkansas allocated \$600,000 to construct a modern swine production facility. As mentioned earlier, this facility is a commercial sized operation that will have multiple long term uses. These include animal production and nutrition research, student education, producer education and as a model for proper facility design and management. To address increasing environmental and odor related concerns, the latest technology for waste management consisting of a solids separation system, followed by a lagoon/holding pond will be implemented to ensure minimum odors and proper manure nutrient management. In addition to standard manure management components, four additional holding basins to facilitate separate manure collection from pigs receiving different diets as discussed above (These holding basins are not needed as a part of the conventional waste management system for the swine facilities and, therefore, are a facilities component necessary specifically for this demonstration). The additional holding basins are needed to avoid mixing of manures from different demonstrations. The separate manure collection system was designed and installed at this farm during construction. The standard solids separation system and lagoon/holding pond combined with the additional holding basins are instrumental in the institutionalization of manure management as a key component of the University's swine production unit. A unit that will not only be used for production, but also a

training facility. Students who will work in the swine industry after graduation and current producers will receive the benefits of training in proper manure management technology. These facilities and the management team will also be in place for demonstration of additional technologies with potential to institutionalize the approaches used in this demonstration as a means of continuing the working relationship with the swine industry in implementing improved waste management BMPs.

Since 1993, educational efforts have made producers aware of the design and management differences of holding ponds and lagoons. The educational efforts have also presented the recommended agitation and solids removal practices. As a result, progress is being made on many farms to avoid the lost storage capacity. However, this progress will be greatly enhanced by demonstration of the pumping and agitation equipment in operation.

Producer field days with vendor and manufacture participation have been held in the past to demonstrate pumping and agitation equipment. However, these types of field days demonstrate only the operation of the equipment. They do not provide the opportunity to document and demonstrate the long term advantages of proper manure solids handling. A better approach is to track manure solids volumes and the long term effectiveness of proper management. The use of a new settling basin and measuring the solids volume over time were used to demonstrate the effectiveness of agitation in maintaining storage capacity. Using a settling basin with accumulated solids allows the demonstration of the effectiveness of agitation for the recovery of storage volume.

The management of a new settling basin has been demonstrated on the Universities new swine facility. Construction will not be funded by this grant nor used as matching funds since this component of the demonstration will be funded as part of the normal construction costs. To demonstrate the effectiveness of agitation, two verification farms with a settling basin with accumulated solids were selected. The verification farms were also used to demonstrate the impact of phytase-amended feed.

### **Manure Solids Demonstration**

For the manure solids demonstrations, the solids content of the settling basin was measured prior to each pump down. To make the measurements a GPS unit capable of sub meter accuracy after differential correction was use in conjunction with a transit and survey rod. The rod was modified by attaching a 6 inch diameter plate to the foot. The plate allowed the rod to rest on top of the manure solids during a measurement. The GPS's antenna was attached to the top of the rod. At each measurement site the depth of the water above the manure solids was read directly from the rod. This value was entered into the handheld computer that collected the location information for the site. As a result at each measurement site an X, Y, and Z coordinates were recorded. A small boat was used to make collect measurements that could not be collected from the bank. Rather than follow a rigid grid pattern measurement locations were determined by observed variation in the manure solids surface during the data collection process. More points were collect where the surface elevation changed rapidly, while the density of the sampling locations was decreased where the surface elevation was relatively consistent.

Since the water level in the manure storages varied, a permanent Benchmark was established for each manure storage unit. For each set of measurements the vertical distance from the Benchmark to the water surface was measured. This distance and the water depth at each location

enabled the calculation of the elevation of the manure solids surface relative to the Benchmark elevation for each measurement site. This permitted the comparison of information collected for each set of measurements. These comparisons provided trend information on the reduction/accumulation of manure solids.

To make the comparisons the field data was differentially corrected using base station records. After this water depth values were converted to manure solids elevation values using the vertical distance from the Benchmark to the water surface. The resulting data files were then analyzed using ArcView 3.2. The analysis consisted of generating a TIN surface for each set of measurements. Cut/Fill calculations were then made comparing the different sets of measurements collect for each manure storage unit.

The precision of the GPS location for each location varied from 0.24 to 1.05, with an average of .44 meters. Additional factors affecting the precision of the collected information included, difficulty holding the rod vertical in windy conditions, a tendency for the rod to settle into the manure solids, and reading the water depth when there was a floating layer of manure. As a result the precision of the vertical measurements was about 1.5 cm. Given these levels of precision and the focus of the demonstration on trend analysis ArcView's graphical capability was emphasized during the data analysis.

Manure samples were also collected using a pipe style collector. The manual foot valve on the collector allowed the entire profile of the manure storage unit to be collected in one sampling, or discrete samples could be collected at any depth from the water surface to the settled manure solids.

Enough manure samples were collected to guide manure application rates, demonstrate the variability of the manure with depth and time, and demonstrate the variability of manure nutrient concentration between the different types of manure storages.

### **Demonstration of phytase efficacy**

A second major effort of this demonstration project was to demonstrate the use of dietary phytase addition to substantially reduce phosphorus production in swine manure without impacting swine performance or profitability.

#### **Nursery demonstration**

A total of 216 (Dekalb line 348) barrows and gilts were used to monitor the effect of reduced dietary phosphorus on performance of nursery pigs placed in the wean-to-finish facility. The pigs originated from London, Ontario, Canada and were weaned at approximately 17 days of age. Pigs were housed in a wean-to-finish facility in totally slatted pens (1.52 m x 3.05 m) equipped with radiant heaters, a two hole nursery feeder and wean to finish cup waterers. Ambient room

temperature was maintained at approximately 78 C. In addition, a radiant heater provided supplemental heat to a 6' diameter area covering two pens/heater. The study was designed with pigs in 18 pens fed the control normal phosphorus diet and pigs in 18 pens fed the reduced phosphorus diet with added phytase (Table 1). Phosphorus content of the normal phosphorus diets were formulated based on NRC, 1998 recommendations which are somewhat below industry standards. Phosphorus content of the diet was reduced by 0.1% available phosphorus and phytase was added to provide 500 phytase units/kg of feed by adding Ronozyme<sup>®</sup> P (Roche vitamins, Parsippany, NJ) at a rate of 0.6 lb/ton. Diets were analysed to assure that the 500 active phytase units/kg of feed were present after diets were pelleted. Pigs were weighed on a pen basis on Days 0, and at the end of phase 1 (day 14) and phase 2 (day 28) of the nursery period. Feed disappearance from each pen self-feeder was calculated as the difference between feed added and feed weighed back for each of the following periods: 0 - 14d, 14 - 28d and 0 - 28d. Average daily gain, average daily feed intake and gain:feed ratios for each period were then calculated. All diets contained 0.15% of a custom-formulated trace mineral premix which provided 16 ppm Cu from CuSO<sub>4</sub> and 165 ppm Zn from ZnSO<sub>4</sub> and the diets provided an additional 176 ppm Cu from CuSO<sub>4</sub> and 1800 ppm Zn from ZnO in phase 1 and 1715 ppm Zn in phase 2.

#### Growing/finishing demonstration

Performance was monitored in a second group of 216 (Dekalb line 348) barrows and gilts during the growing/finishing period (22 to 106 kg) . Pigs were housed in a wean-to-finish facility in totally slatted pens (1.52 m x 3.05 m) equipped a single hole finishing feeder and wean-to-finish cup waterers. Ambient room temperature was maintained at approximately 70 F. The study was designed with pigs in 18 pens fed the control normal phosphorus diet and pigs in 18 pens fed the reduced phosphorus diet with added phytase (Table 2, Table 3). Phosphorus content of the normal phosphorus diets were formulated based on NRC, 1998 recommendations which are somewhat below industry standards. Phosphorus content of the diet was reduced by 0.1% available phosphorus and phytase was added to provide 500 phytase units/kg of feed by adding Ronozyme<sup>®</sup> P (Roche vitamins, Parsippany, NJ) at a rate of 0.6 lb/ton. Diets were analysed to assure that the 500 active phytase units/kg were present after diets were pelleted. Pigs were fed a four-phase diet with transition from grower I to grower II, from grower II to finisher I and from finisher I to finisher II occurring when the mean weight of each block reached approximately 45 kg, 68 kg, and 90 kg, respectively. All diets met, or exceeded, NRC (1998) requirements for all nutrients and were formulated to simulate diets typical of those used in the integrated swine industry. This study was terminated when pigs reached an average weight of 235 lb. Feed disappearance from each pen self-feeder was calculated as the difference between feed added and feed weighed back for each feeding period. Average daily gain, average daily feed intake and gain:feed ratios for each period were then calculated. All diets contained 0.15% of a custom premix that provided 7.5 ppm Cu from CuSO<sub>4</sub>, and 77 ppm Zn from ZnSO<sub>4</sub> in the complete diet. An additional 175 ppm Cu was provided by supplementing the diets with CuSO<sub>4</sub>.

With the initial population of the new University of Arkansas Wean-to-finish facility, pigs placed in Barn 1 were used to produce two types of manure that was stored in a total of 4 holding ponds. Two ponds were constructed to receive manure from the northern one-half of the facility (total of 36 pens). Pigs placed in these pens received normal phosphorus diets devoid of phytase

and pigs placed in the southern one-half of the facility (total of 36 pens) received manure from reduced phosphorus diets supplemented with phytase. The holding ponds were managed by emptying the shallow pit under the pigs on each diet on a weekly basis and recharging the pit with effluent from the top of the holding pond. This simulated the management of a pull-plug waste disposal system and allowed the accumulation of the two types of manures for application on the watersheds.

We also demonstrated the reduced risk of phosphorus (P) runoff from watersheds receiving manure from phytase-treated pig diets in relation to manure from pigs fed normal phosphorus, non-phytase diets. Two additional watersheds were added to the project using funds from other sources. Concern over water quality near animal production facilities is primarily with regard to transport of excessive amounts of nitrogen (N) and/or P from the animal waste.

The additional watersheds included a watershed with no added fertilizer or manure and one to evaluate the efficacy of aluminum chloride addition to swine manure on runoff. Shreve et al., 1995, Moore et al., 1995, and Smith et al., 2001 recommended treatment of manure with aluminum chloride as a means of reducing both P and NH<sub>3</sub> losses. The field demonstrations took place in Years 2 and 3, and watershed sites were designated:

1. No manure or fertilizer application
2. Phytase manure - Low P diet, high N, but low P loading, lower risk of P runoff.
3. Normal manure - normal P diet, high N and P loading on pasture, high risk of P runoff.
4. Phytase manure - Low P diet, high N, but low P loading, aluminum chloride added to reduce soluble phosphorus and lower risk of P runoff.

The four small watershed (0.5 acre each, earthen-berm delineated) were constructed at the University of Arkansas swine farm at Savoy, to monitor N and P constituents in runoff water following storm events. The two manure types were transported from their respective holding basins in a honey wagon and applied to two separate pastures in multiple applications at rates equivalent to a target of 200 lb N/acre/year. Manure from pigs fed the reduced phosphorus diet with added phytase was also treated with aluminum chloride by adding 0.75% aluminum chloride to the manure in the honey wagon prior to application. This was added to a third watershed at the same application rate used in the other watersheds. A fourth watershed had no manure or fertilizer added. A total of three applications were made during the project. Watersheds and the applications for each watershed are illustrated in Figure 1.

A “Small In-field Runoff Collector” system. (Figure 2) was used to collect runoff water. This system was designed with 10 flow channels separating flow three times to allow collection of 1/10, 1/100 or 1/1000 of the runoff from each watershed. The system was calibrated by running a known quantity of water through the system and the calibrated flow data were used to calculate runoff with each storm event. The “Small In-field Runoff Collector” system was used to collect runoff water samples from each watershed and storm event. These samples were composited and analyzed for total kjeldahl N, total P, soluble P, NH<sub>3</sub>-N, NO<sub>3</sub>-N, copper and zinc.

Soil in each watershed was sampled for total kjeldahl N and total and soluble P at the start, middle and end of the project. Estimates of P and N in feed input to the farm, manure output to

the field, nutrient storage in soil, uptake by plants, and loss in runoff was used to calculate gross P and N budgets for the entire swine operation. The results of the phytase addition, manure management, and field activities was to demonstrate the benefits of judicious management of animal waste and nutrients to not only promote economic forage and beef production but also to maintain environmental quality.

### **Forage sampling and cattle management**

**Preparation:** The entire pasture area was sprayed with Roundup during the summer and early fall of 2001 to kill existing bermudagrass and fescue. The area was seeded in late August by no-till drill with MaxQ® tall fescue seed. MaxQ is a tall fescue product that contains an endophytic fungus that aids with plant persistence, but does not produce compounds that are toxic to grazing livestock.

**Grazing management:** As tall fescue is the predominant forage in the demonstration pastures, grazing was conducted during the spring and fall, with cattle removed during the summer. Stocker cattle were weighed without prior removal from feed and water and allocated randomly to one of the experimental watersheds. The initial stocking rate was established at 3 calves (approximately 452 lb each) on each pasture on May 21, 2002. Calves were allowed access to their respective pasture until June to control forage growth. Steers were removed from experimental watersheds when available forage dropped to 1000 lb dry matter per acre. Animal numbers was adjusted to control available forage growth. The pastures were not grazed during the summer months to allow re-growth for the fall grazing period. Cattle were then allocated to the experimental watersheds in mid-September and allowed to graze until approximately early to mid-November depending upon available forage. Calves were removed at that time and watersheds were not grazed during the winter months.

### **Forage sampling and measurements**

Forage samples were obtained from each watershed, but were analyzed for N and P only in watersheds receiving manure from pigs fed the reduced phosphorus diet with added phytase and pigs fed the normal phosphorus diet. Three enclosures were placed in each experimental watershed prior to the initiation of grazing. These enclosures were used to prevent grazing of those areas so that forage growth could be monitored. At the initiation of grazing and at regular intervals during the grazing period, available forage was determined at 12 locations within each watershed using a disk meter (Bransby et al., 1977; Karl and Nicholson, 1987). Initial available forage within each enclosure was determined using a calibrated disk meter. At subsequent samplings, forage samples from inside each enclosure were clipped inside a .25 m<sup>2</sup> frame to a height of 1 inch. The enclosure was moved to a new location at each sampling and the available forage inside the new location was determined using a disk meter. The disk meter was calibrated each sampling by first obtaining a disk meter reading on five different locations with varied available forage. The forage beneath the disk meter was then clipped to a height of 1 inch, dried, weighted, and converted to a per-acre basis. These values were used to establish a best-fit regression equation that was used to determine available forage from the 12 disk meter readings

within each watershed. The  $r^2$  values for regression equations determined as described were at or above 0.9 on each sampling date. Twelve forage samples were gathered from within each experimental watershed in a random zigzag pattern clipped to a height of 1" for determination of N and P concentrations.

Nutrient uptake: Forage growth during each sampling period was determined by difference between the initial disk meter reading and clipping the standing forage the following month. Initial forage nutrient concentrations were determined from hand-gathered samples. This value was multiplied by the initial forage mass within the enclosure as determined by disk meter to determine the amount of nutrient available on day 0. Forage yield as determined by clipping the forage within the enclosure 28 days later was multiplied by the concentration of each nutrient in the clipped forage sample. Nutrient uptake by the forage was determined by difference between these two numbers. Forage and nutrient removal was estimated by the changes in each measurement corrected for forage growth during the respective period.

Technology transfer was accomplished through field days, and already established avenues of dispersing information. The field days took place at the University swine farm to show the results of manure solids management, adding phytase to the feed, and reduced runoff demonstrations.

The established avenues for distributing information are the four hours of annual training that every permitted swine producer receives each year, the Arkansas Pork Producers Association (APPA) annual convention, newsletters and mailings sent out to APPA members, and production training that Tyson and Cargill provide their contract growers and personnel. These established opportunities assure the distribution of the demonstration results to a very large percentage of the swine producers.

The demonstration results will be distributed via printed materials and presentations. The printed materials will consist of brief project updates in mailings sent out by APPA. Presentations will be made and publications handed out at the annual training provided for producers. Presentations and publications will also be made available for use in APPA's annual conventions and industry production meetings.

In addition to the dissemination of information to the Arkansas swine industry, the demonstration results and printed materials will be forwarded to the National Pork Producers Council for use in their national educational efforts. This will help ensure that this project not only has a state-wide but also national impact.

The swine industry has shown great interest in the development of new swine facilities and a revitalized swine teaching and education effort at the University of Arkansas. We propose to utilize this renewed interest by the swine industry in a swine Teaching and Education Program at the University of Arkansas as a means of developing partnerships with the swine industry and the public to demonstrate technologies which have the potential to resolve industry problems. The industry faces no greater problem than that posed by waste management concerns of the public.

## **Project findings:**

### **I. Solids Management and Verification Farms**

#### **Manure Solids Accumulation/Reduction Findings.**

Manure solids accumulation/reduction trends were determined on three farms. The University of Arkansas Swine Facility has a settling basin followed by a lagoon. On this farm both the settling basin and the lagoon are significantly oversized. They were designed to store all the manure from a small commercial scale farrow-to-finish operation. However only the finishing floors were built. In addition this project included the construction of 4 additional holding ponds to store the manure applied to the demonstration plots. As a result only the manure from ½ of the finishing animals was stored in the settling basin and lagoon. As a result the 45 days of storage in the settling basin was closer to 100 to 120 days. As expected the reduced loading to the lagoon reduced the rate of solids accumulation.

Figures 3 and 4 present the findings of the manure solids measurements at the university farm. The settling basin was agitated with either the university's prop style agitator or with a custom applicator's trailer mounted pump agitator. As indicated by Figure 3, both agitators were adequate to agitate the settling basin and prevent the long-term buildup of manure solids. However the trailer mounted pump took less time to thoroughly agitate the manure. It also had the advantage of being able to load a honey wagon more rapidly than the suction line on the honey wagon. The disadvantage was a higher purchase price and horsepower requirements.

The lagoon had a net increase in manure solids as was expected since the lagoon by design was not agitated when manure was land applied. However, due to the reduced loading rate the solids accumulation was minimal.

Both of the verification farms were at least 15 years old and had a history of manure accumulation in both their settling basins and holding ponds. Just prior to the initiation of the project Mr. Faulkner had built a commercial quality prop style agitator and was starting to address the manure solids problem. During the course of this project Mr. Townsell either used Mr. Faulkner's agitator or hired a custom applicator with a pump style agitator. Figures 5, 6, 7, and 8 show that both farms were able to make progress on removing the accumulated manure solids with the available equipment. However, the settling basin on the Faulkner farm was exceptionally difficult to agitate and keep agitated. On the Faulkner Farm the manure solids in the settling basin had the consistency of coarse river sand. While the manure solids in the holding pond was gelatinous and easily agitated. It appears that the "sand" in the settling basin is coming from the concrete as the floor of the hog houses wears and decays with age. This problem has been reported on other farms as well.

Inspection of Figures 3-8 also shows that in addition to agitation the manure solids the agitators also move the solids around based on where they are located and operated. This verifies the often-reported occurrence of agitators "building" and island of solids in the center of large holding ponds. This probably occurs because the center of the pond is beyond the effective



“throw” distance of the agitator being used. This is a strong indicator for the need to consider alternative to agitation for large ponds and lagoons to remove solids. However, for settling basins and smaller holding ponds the available agitators are adequate to both prevent solids accumulation and reduce the accumulation that has built up.

### **Phytase findings on the verification farms.**

Both Mr. Faulkner and Mr. Townsell kept animal mortality records before and after the introduction of Phytase to the feed. In the same manner, Cargill Swine, their integrator kept animal production information not only on the Faulkner and Townsell farms but on all of their farms. Neither producers nor Cargill have found any indication that the use of phytase has increase mortality or hurt production. In addition, Mrs. Faulkner who manages the swine houses reported that she could not tell a difference in the physical characteristics of the manure when phytase was used.

### **Manure nutrient findings.**

As this was a demonstration project the number manure samples collect does not allow for exhaustive statistical analysis. Therefore the findings from the collected manure are presented as being typical to what is found on the farms. Figure 9 and 10 demonstrate that even on the limited number of samples from three different farms, there is wide range of both nutrient concentrations and nutrient ratios. This range was exceptionally large in the case of Total P. The higher P values were associated with manure solids collected from the bottom of settling basins and holding ponds.

Figure 11 demonstrates how the nutrient concentration in a settling basin changes over time. In this example, the first sample was collected when the animals were small and the manure-loading rate was low. The second sample was collected latter from the same settling basin after the animals had gotten larger. Comparing Figure 12 with Figure 11 demonstrates that manure from a lagoon is usually much lower nutrient concentrations than from a settling basin. The settling basins higher nutrient concentrations help provide a mechanism to move manure nutrients farther from the source.

One question that comes up fairly regularly is how do you determine manure application rates in the absence of long term farm records. The options are to use a national or regional average which may not reflect what is going to be applied, and collect a sample in the field to determine how much was applied. Or it is conceivable to agitate the pond to get a blended sample to send in for analysis. However, agitation is too labor and financially expensive just to collect a manure sample. The best approach is to collect a representative sample of what will be applied when the pond is agitated. In this project a pipe sampler was used to collect composite samples. Figure 13 shows the results when a settling basin was sampled prior to agitation, and after agitation. Cleary, it is possible to collect an accurate composite sample.

## **II. Effect of Phytase on Animal Performance**

### **Nursery performance**

Nursery performance of pigs during the time they were monitored is presented in Table 4. Average daily gain, average daily feed intake and feed efficiency were similar among pigs fed either the normal phosphorus diet or the reduced phosphorus diet with added phytase during phase 1 of the nursery period and for the overall nursery demonstration. However, during phase 2, gain and efficiency were reduced in pigs fed the reduced phosphorus diet with added phytase. Pig weights throughout the nursery demonstration were similar among pigs fed the two phosphorus diets. Reduced gain and efficiency during phase 2 may be due to the fact that reducing available phosphorus in diets based on NRC, 1998 recommendations by 0.1% and adding phytase may not have provided sufficient phosphorus for rapidly growing pigs. Industry standards are somewhat higher and may be justified.

### **Growing/finishing performance**

Growing/finishing performance of pigs during the time they were monitored is presented in Table 5. Average daily gain was reduced in each phase of growing/finishing in pigs fed the reduced phosphorus diet when compared to those fed the normal phosphorus diet, with the exception of the final finishing phase. This resulted in reduced pig weight at the end of each phase of the study. The magnitude of reduced weight was 2.15 kg at the completion of the study. Average daily feed intake was not affected by dietary phosphorus level and efficiency was similar during all periods of growing/finishing except for a small 2.9% reduction in gain/feed observed in the overall study. Again the reduced gain in all but one of the monitoring periods and the reduced overall efficiency may be due to the fact that reducing available phosphorus in diets based on NRC, 1998 recommendations by 0.1% and adding phytase may not have provided sufficient phosphorus for rapidly growing pigs. Industry standards are somewhat higher and may be justified.

Each of the two holding ponds with the two types of manures were sampled three times during the project, each time just prior to manure application on the watersheds. This provided a total of 6 samples of manure from pigs fed both the normal phosphorus diet and the reduced phosphorus with phytase diet for nutrient analysis. Table 6 provides the average total and soluble phosphorus analysed in these holding ponds. The 24.8% reduction in total phosphorus is consistent with the magnitude of reduction observed in phosphorus balance studies with pigs to determine the magnitude of reduction of phosphorus expected by feeding reduced phosphorus diets with added phytase. The magnitude of reduction in soluble phosphorus was only 8.95% suggesting that a higher percentage of the phosphorus from pigs fed phytase was in the soluble form. This is consistent with other observations that phytase increases soluble phosphorus in manure.

## **III. Effect of Manure Application on Runoff from Watersheds**

Rainfall events and runoff were measured from 4-26-02 through 9-30-03. . Rainfall events and runoff events are recorded in Table 7. A total of 77 rainfall events with rainfall from 0.1” to 6.0” were recorded. A total of 21 rainfall events with measurable runoff were recorded. The rainfall events, which produced a runoff, were quiet variable. The lowest rainfall event to produce a

runoff event was 0.55” whereas the largest rainfall event failing to produce a runoff event was 2.5”. Total runoff data are presented in Table 8. The watershed that received no manure or fertilizer produced the greatest total runoff with 191,344 L. This might be expected since reduced forage cover may increase runoff. The watershed receiving the normal phosphorus manure was next with 179,028 L followed by the watershed receiving manure from pigs fed phytase with  $AlCl_3$  (162,418 L). The watershed receiving manure from pigs fed phytase had the lowest total runoff of 112,826 L.

The total nutrients applied to the watersheds in the three applications are presented in Table 9. Although the application of total N was closer to 150 lbs of total N/ac/year compared to the target of 200 lbs of total N/ac/year, manure application resulted in a substantial load of phosphorus on the three watersheds receiving manure. Total phosphorus application was greatest in the watershed receiving the phytase manure (21.0 lb/ac/yr) and lowest for the watershed receiving the phytase with aluminum chloride manure (17.7 lb/ac/yr). The addition of aluminum chloride to the swine manure also substantially reduced the soluble phosphorus at the time of manure application, as expected.

At the time the watersheds were established, a grid pattern of soil samples over the area were obtain (0 to 6” samples) and initial soil test phosphorus was determined for the watersheds (Mehlich III P). The pattern indicated that the soil samples in the watershed ranged from a low of 53 lbs of P/ac to a high of 106 lb P/ac (Figure 14), however the majority of area within the watersheds ranged from 60 to 93 lb of P/ac. The total soil test P analyzed from composite samples obtained from the watersheds (0 to 6” samples; Table 10) at the initiation of the study indicate that the phosphorus ranged from a high of 1032 lb of P/ac in watershed 1 receiving no manure to a low of 902 lb total phosphorus/ac in watershed 4 receiving phytase with aluminum chloride treated manure. Total soil test phosphorus in watershed 2 receiving phytase manure and watershed 3 receiving normal manure was intermediary. Total soil test phosphorus increased in all watersheds receiving manure with each subsequent application of manure. Total soil test phosphorus remained relatively constant in the watershed receiving no manure (watershed 1) but increased in watersheds 2, 3, and 4 receiving manure by 32.9%, 25.0% and 35.7% respectively after three manure applications. Similarly, the increase in soluble phosphorus using either 0 to 2” samples or 0 to 6” samples was much greater in watersheds receiving either phytase phosphorus or normal phosphorus manure (watershed 2 and 3, respectively compared to the watersheds receiving no manure or phytase +aluminum chloride manure (watersheds 1 and 4, respectively; Table 11). Aluminum chloride addition was very effective in reducing soluble phosphorus measured in either the 0 to 2” sample or the 0 to 6” sample. Mehlich III phosphorus increased at each soil sampling period in all watersheds receiving manure.<sup>4</sup>

Phosphorus concentrations from the runoff events are shown in Figure 15. The unfertilized watershed tended to have the lowest soluble and total P concentrations. The highest soluble P and total P concentrations were observed from the watershed fertilized with phytase manure, although the reduction in the concentrations of soluble P and total P observed in the normal manure fertilized watershed was very small when compared to the watershed fertilized with phytase manure. These observations are consistent with observations that indicate that potential

---

44

P losses may be increased with phytase (Moore et al., 1998; DeLaune et al., 2001) and also consistent with the observed higher percent of phosphorus in the soluble form in ponds containing phytase manure. From the watersheds fertilized with manure, the lowest soluble and total P concentrations were noted in the phytase with  $\text{AlCl}_3$  treatment. These data indicate that phytase and  $\text{AlCl}_3$  can be used together to reduce potential P runoff resulting from fertilization with manure, although the reduced magnitude of runoff are not as great as one might expect based on the degree of reduction in soluble P applied.

Ammonia concentrations in runoff were similar among watersheds receiving no manure and those where phytase or normal manure were applied (Figure 16). Ammonia concentrations, however, were elevated in runoff in the watershed fertilized with phytase with aluminum chloride manure compared to the other three watersheds. The higher  $\text{NH}_4^+$  runoff from the  $\text{AlCl}_3$  treated manure may have occurred due to reduced  $\text{NH}_3$  volatilization after surface application resulting from a reduction in manure pH (Smith et al., 2003). Nitrate concentrations in runoff were increased with manure applications with the greatest increases observed in watersheds receiving phytase manure (Five fold increase) and phytase with  $\text{AlCl}_3$  (Four fold increase) compared to the unfertilized watershed. Normal manure more than doubled  $\text{NO}_3$  runoff concentrations compared to the unfertilized watershed.

Zinc concentrations from runoff were very low (Figure 17). Manure had no apparent impact on metal runoff when applied as a fertilizer resource to the watersheds. Copper concentrations in runoff were also very low, in the ppb range, and were not impacted by the addition of manure to the watersheds (Table 12).

The mass of soluble and total P lost from the watershed fertilized with normal manure was greater when compared to the runoff in the unfertilized watershed or watersheds fertilized with phytase manure or phytase manure with  $\text{AlCl}_3$  (Table 13). This total mass of P loss in the watershed fertilized with normal manure also represented the greatest percentage of applied total P lost among the watersheds (5.4% vs. 3.6% and 4.9% for the watersheds where phytase manure and phytase with  $\text{AlCl}_3$ , respectively). Application of manure from pigs fed phytase, with or without treatment with  $\text{AlCl}_3$ , reduced the mass of soluble and total P runoff. In fact, the watershed treated with phytase manure produced the lowest total P and percentage of soluble and total p runoff among the watersheds, even lower than that observed in the unfertilized watershed. It should be noted, however, that runoff volumes were variable between watersheds which had an impact on the total mass of nutrients lost from the runoff events. When comparing the mass of nutrients applied to that which was lost through runoff, it is important to note that the vast majority of nutrients remained within the watershed. In general, more than 90% of the nutrients applied remained in the watershed. The exceptions to this are the percentage of soluble P lost from the watershed receiving the normal P manure (12.7%) and the percentage of soluble P lost from the watershed receiving the phytase manure with  $\text{AlCl}_3$ . (165%). A higher percentage of soluble nutrients were lost through runoff, because the soluble fraction is fairly dynamic, and is also more susceptible to runoff losses than the total fraction. There was more soluble P removed from the phytase manure with  $\text{AlCl}_3$  watershed than was applied from the manure, most likely due to the natural loss of soil P as seen in the unfertilized watershed. The N lost from these watersheds was a very small fraction of what was applied ranging from 0.6% to 1.2%.

One of the objectives of this project was to conduct a phosphorus and nitrogen budget for the farm. A total of 8,222 lb of phosphorus was delivered to the farm and an estimated 2,507 lbs (30.5%) was removed in pigs marketed or retained in pigs kept as replacements breeding stock (Table 14). A total of 1,616 lbs (19.6%) was spread on 88 ac for an average application rate of over 12 lbs of total P/ac/yr which exceeds the P needed for forage production for grazing or hay. The amount of total N delivered to the farm was 40,839 lb (Table 15). An estimated 11,608 lbs (28.60%) was removed in pigs marketed or retained in pigs kept as replacements breeding stock. A total of 3,655 lb. (8.94%) was spread on 88 ac for an average maximum application of 41.50 lbs of N/ac. If one obtained the expected ammonia loss from volatilization of 25%, then the actual applied N would be about 31 lb/ac which is probably below the crop needed for either the Bermuda or Fescue pastures where manure is applied. The residual N is most likely much less than the calculated residual since ammonia volatilization from the production facility and holding ponds is likely to be substantial.

#### **IV. Forage Production and Grazing Demonstration**

As indicated earlier, the forage and animal components of the study only evaluated the impact of manure from the watersheds receiving normal and phytase manure due to cost constraints of forage mineral analysis.

Available forage was higher on May 21 from the watershed fertilized with normal P manure (Table 16). Both watershed had considerable forage accumulation prior to the beginning of grazing on May 21. Grazing was initiated late primarily because of delays in getting fences constructed. However, the initial stocking rate was increased in order to consume the available forage in a reasonable time period prior to the onset of summer. Available forage was similar between the two watershed when the calves were removed on June 14. Estimated forage growth during the grazing period was higher from the watershed fertilized with phytase manure, but estimate forage removal during the spring grazing period was higher from the watershed fertilized with normal manure. Forage growth during the summer and fall growing seasons resulted in similar available forage on December 12 when the late-fall grazing period began. Forage growth during the grazing period was low on both treatments, but estimated forage removal was much greater from the watershed fertilized with phytase manure. During the spring 2003 grazing season, forage growth and removal was greater from the watershed fertilized with phytase manure.

Forage P uptake prior to the first grazing period, as estimated by multiplying the initial forage mass by the P concentration, was 5.3 lb/acre higher from the watershed fertilized with normal P (Table 17). Uptake of P during the grazing period between May 21 and June 14 was 4.4 lb/acre higher from the watershed fertilized with phytase manure. Uptake of P following the fall manure application but prior to initiation of grazing on December 2 was approximately 4.6 to 4.7 lb/acre on both watersheds. Uptake of P throughout the entire first year was slightly higher (2.2 lb/acre) from the watershed receiving normal P manure. Trends were somewhat reversed in 2003, as initial P uptake and total uptake by July 10 was greater from the watershed fertilized with phytase manure.

Phosphorus removal represents the amount of P that disappears from the pasture based on forage disappearance. Because of the relatively small amount of P in animal tissue growth (~ 0.59%), this number likely represents P that was consumed by the grazing animal, was trampled, or was consumed by insects, etc. Much of this amount would be assumed to simply be transported to another location in the form of manure deposits, etc. Estimated P removal during 2002 varied little between the two manure types when totaled across both grazing periods (Table 17). Estimated P removal during the spring 2003 grazing period was slightly higher from the watershed fertilized with normal P manure.

Forage N uptake followed the same trend as was observed for P uptake in that initial N uptake was greater from the watershed fertilized with normal P manure (Table 18). During the spring grazing period of 2002, N uptake was greater from the watershed fertilized with phytase manure. Overall N uptake during 2002 varied little between manure types. Uptake of N prior to the initiation of grazing during the spring of 2003 was greater from the watershed receiving phytase manure such that overall N uptake by July 10 was 58.4 lb/acre greater from the watershed fertilized with phytase manure. Estimated N uptake during the spring 2003 grazing period was negative from both watersheds. These negative values are difficult to explain, but are possibly due to errors associated with estimating forage growth rate when the enclosure cages are moved after each sampling. By moving the cages, it is possible to select a site for which the N was excessively applied or was applied at a lower rate, leading to erroneous values for plant N concentrations between microsites. We felt that moving the cages would give a better representation of actual forage growth however, because the growth rate of grazed and ungrazed forage is usually different over a longer period of time, such as the time between April 3 and July 10. Estimated N removal was greater from the watershed fertilized with phytase manure during both grazing periods of 2002 and during the spring grazing period of 2003. Total N removed was estimated at 39 lb/acre more during 2002 and 29 lb/acre more during the spring of 2003 from the watershed fertilized with phytase manure.

Animal gain per acre values and resultant estimations of P and N removal in the form of calf gains are reported in Table 19. Treatment differences should be viewed with caution because of the small number of animals represented within each watershed. Animal to animal variation in growth within a watershed was highly variable. Gain per acre totals for 2002 appeared to favor the watershed fertilized with normal P manure, but the reverse trend was found in the 2003 grazing period. Total gain/acre across 2002 and 2003 grazing periods was 131 lb greater from the watershed fertilized with phytase manure. However, because of the small amount of P and N removed as animal tissue growth, the difference between watersheds was only 0.8 and 1.3 lb/acre of P and N respectively.

Based on this information, it is reasonable to assume that a high proportion of P and N from swine waste will be taken up into the tissue of tall fescue plants growing on swine manure - amended sites. However, a high proportion of the P and N consumed by the grazing animal goes to tissue maintenance which is dynamic. Because of this, the major portion of P and N consumed and absorbed simply replaces other P and N in the body, and only a small proportion of the P and N consumed by the grazing animal is actually deposited in tissue that can then be removed from the system. Therefore, the most logical practice to remove or utilize excess P and

N from the respective area would be to harvest the resulting forage and feed it in a location with lower P and N concentrations.

## **Project Summary:**

Manure solids accumulation/reduction trends were determined on three farms. The University of Arkansas Swine Facility has a settling basin followed by a lagoon. As expected the reduced loading to the lagoon reduced the rate of solids accumulation. Both of the verification farms were at least 15 years old and had a history of manure accumulation in both their settling basins and holding ponds. Both farms were able to make progress on removing the accumulated manure solids with the available equipment. Manure was difficult to agitate and keep agitated on one demonstration farm as the manure solids in the settling basin had the consistency of coarse river sand. This demonstration verifies the often-reported occurrence of agitators “building” and island of solids in the center of large holding ponds. This probably occurs because the center of the pond is beyond the effective “throw” distance of the agitator being used. This is a strong indicator for the need to consider alternatives to agitation for large ponds and lagoons to remove solids. However, for settling basins and smaller holding ponds, the available agitators are adequate to both prevent solids accumulation and reduce the accumulated solids.

Phosphorus (P) runoff from pastures fertilized with animal manure contributes to eutrophication of surface water. Ammonia (NH<sub>3</sub>) losses are a source of odor from swine manure and may contribute to impaired animal and human health as well as acid rain deposition. Dietary modification with phytase has been proposed as one method to reduce potential P losses from fields fertilized with animal manure (Nelson et al., 1968), and may be able to reduce NH<sub>3</sub> volatilization (Smith et al., 2002). However, some studies indicate that potential P losses may be increased with phytase (Moore et al., 1998; DeLaune et al., 2001). Manure amendments such as aluminum chloride (AlCl<sub>3</sub>) have also been recommended to reduce both P and NH<sub>3</sub> losses (Shreve et al., 1995; Moore et al., 1995; Smith et al., 2001). This project was conducted to determine the impact of dietary phytase on animal performance and nutrients and metals lost when swine manure is used as a fertilizer resource. Monitoring the effects of reduced phosphorus diets with added phytase on performance during the nursery phase indicated that overall performance was similar. However, during the finishing phase, a small reduction in gain and efficiency was observed in pigs fed the reduced phosphorus diet with added phytase. Decreased performance may be due to the fact that reducing available phosphorus in diets based on NRC, 1998 recommendations by 0.1% and adding phytase may not have provided sufficient phosphorus for rapidly growing pigs. Industry standards are somewhat higher and may be justified. Concentrations of soluble and total P in runoff were increased in the watersheds where either normal manure or phytase manure was applied compared to no manure application. Treating phytase manure with AlCl<sub>3</sub> reduced soluble and total P runoff, but concentrations were above background runoff observed in the unfertilised watershed. Ammonia and nitrate concentrations tended to be elevated in runoff from watersheds treated with either phytase manure or phytase manure treated with AlCl<sub>3</sub>. Zinc and copper concentrations in runoff were very low and were not impacted by manure application. The mass of soluble and total P lost from the watershed fertilized with normal manure was greater when compared to the runoff in

the unfertilised watershed or watersheds fertilized with phytase manure or phytase manure with  $AlCl_3$ . Application of phytase manure produced the lowest percentage of applied total phosphorus in runoff (3.6%) whereas application of normal manure produced the highest percentage of total P in runoff (5.4%).

The forage and animal components of the study only evaluated the impact of manure application in the watersheds fertilized with normal and phytase manure due to cost constraints of forage mineral analysis. In these two watersheds monitored for forage and cattle gain, a high proportion of P and N from swine waste was taken up into the tissue of tall fescue plants growing on swine manure amended sites. However, a high proportion of the P and N consumed by the grazing animal goes to tissue maintenance which is dynamic. Because of this, the major portion of P and N consumed and absorbed simply replaces other P and N in the body, and only a small proportion of the P and N consumed by the grazing animal is actually deposited in tissue that can then be removed from the system. Therefore, the most logical practice to remove or utilize excess P and N from the respective area would be to harvest the resulting forage and feed it in a location with lower P and N concentrations.

### **Public Participation:**

This project had two primary goals. The first was to conduct demonstrations that illustrate the efficacy of routine solids management as a means of controlling solids in settling basins and in lagoons. Maintaining storage capacity and adequate freeboard in the storage structures will minimize the risk of point source discharges and permit more flexibility in manure application to accommodate variation in soil moisture levels. The second primary goal was to demonstrate BMPs which can reduce phosphorus excretion by swine and demonstrate the effect on controlling phosphorus runoff. The public was informed of the planning process through partnership building. Phytase technology has been implemented by both Cargill and Tyson swine groups which represents more than 90% of swine produced in Arkansas.

### **Measures of Success and Performance**

**Solids management:** Through the term of this project we estimate that 20 additional producers implement proper manure solids management. Over the next ten years, we expect 90% of all swine producers to be using proper manure solids management practices.

**Phytase:** Approximately 60,000 hogs were produced in the Illinois River basin in Arkansas each year at the time this project was initiated. There are approximately 7.5# of elemental P excreted in the waste of each of these hogs for a total of 450,000# per year in the basin. The use of Phytase as a feed additive resulted in a 25% reduction in waste P in this demonstration. If one assumed that the % reduction in the watershed was the 25% reduction observed in this demonstration, then the total P produced by hogs in the watershed would be reduced to 337,500#. If one obtained the same 3.6% of applied P loss observed from the phytase P in this demonstration in the entire watershed, then the edge-of-field loss would be 11,812 lb of P compared to an estimated 5.4% edge-of-field loss of 24,300 lbs of P if the entire watershed received the normal P diet. This amounts to a 51% reduction in edge-of-field P runoff. Another means of evaluating impact is to assume that almost all of this waste will be land applied within



the watershed. In the Lake Eucha Diagnostic Feasibility Study conducted by the Oklahoma Conservation Commission, they concluded that the load in the lake was 21/2 percent of the P produced in the watershed. If the same relationship holds in the Illinois River basin, then we can expect to see a P load reduction of +/- 2,800# per year or 1300 Kg. The estimated average load in the basin from 1980 through 1993 was 217,000 Kg./year. Therefore, a P load reduction of 6/10% could be realized if Phytase were used as a feed additive. A survey of feeding swine in Arkansas indicates an over 90% implementation of phytase use in the state. This is the result of implementation of phytase technology by both the Cargill and Tyson swine groups, which represents more than 90% of swine produced in Arkansas. It should be noted that the actual reduction in phosphorus loading in the Illinois River watershed from swine operations is much greater than the above estimations would indicate since Tyson Foods, Inc stopped finishing pigs in Arkansas. Although current data are not available, our estimates are that fewer than 5,000 hogs are produced annually in the Illinois River basin. In the Illinois River watershed, we estimated that after completion of this demonstration and education program, the level of participation would reach 80%. We estimated that 50 to 60% participation would be obtained in Arkansas. Participation has been greater than our estimates. The primary reason for the increased participation is due to the development of a more heat stable phytase that can be added prior to pelleting. This removed the necessity of an added large expense of a post pelleting spraying system for each pellet mill. The price of phytase also was reduced so that adding increased phytase activity to the feed prior to pelleting to account for any loss during pelleting became feasible. The increased visibility of the phosphorus problem in NW Arkansas and the interest in companies participating in programs that have the potential of mitigating the problem also played a role in implementation in phytase technology.

### **Reference to Project in the NPS Management Program**

The updated State NPS Management Program includes action items for training for liquid animal waste producers and for demonstration of new and innovative animal waste management practices.

### **Project Lead**

Charles Maxwell  
E-207 Animal Science Building  
University of Arkansas  
Fayetteville AR 72701  
Phone 501-575-2111

### **Literature Cited**

Bruce, J.A.M., and F. Sundstol, 1995. The effect of microbial phytase in diets for pigs on apparent ileal and fecal digestibility, pH, and flow of digesta measurements in growing pigs fed a high-fiber diet. *Can. J. Anim Sci.* 75:121.

Cromwell, G.L., and R.D. Coffey. 1991. Phosphorus-A key essential nutrient yet a possible major pollutant-its central role in animal nutrition. In *Biotechnology in the Feed Industry* p133.

Daniel, T.C., A.N. Sharpley, D.R. Edwards, R. Wedepohl, and J.L. Lemunyon. 1994. Minimizing surface water eutrophication from agriculture by phosphorus management. *J. Soil and Water Conservation* 49 (2): 30-38.

DeLaune, P.B, P.A. Moore, Jr., D.C. Carmen, T.C. Daniel and A.N. Sharpley. 2001. Development and validation of a phosphorus index for pastures fertilized with animal manure. In (G.B. Havenstien ed) *Proceedings of the International Symposium Addressing Animal Production and Environmental Issues*. Research Triangle Park, NC. Oct. 3-5, 2001 [CD-ROM]

Knabe, D. and P.O. Quinn. 1996. Use of Natuphos™ phytase in swine diets: Growth, carcass and meat sensory evaluation. BASF Symposium, North Carolina Swine Nutrition Conference, November 12.

Moore, P.A., Jr., T.C. Daniel, D.R. Edwards and D.M. Miller. 1995. Effects of chemical amendments on NH<sub>3</sub> volatilization from poultry litter. *J. Environ. Qual.* 24:293-300.

Moore, P.A. Jr., M.L. Self-Davis, T.C. Daniel, W.E. Huff, D.R. Edwards, D.J. Nichols, W.F. Jaynes, G.R. Huff, J.M. Balog, N.C. Rath, P.W. Waldroup and V. Raboy. 1998. Use of high available P corn and phytase enzyme additions to broiler diets to lower phosphorus levels in poultry litter. In (J.P. Blake and P.H. Patterson eds) *Proceedings 1998 National Poultry Waste Symposium*. October 19-21, 1998. Springdale, AR.

Nelson, T.S., T.R. Shieh, R.J. Wedzinski and J.H. Ware. 1968. The availability of phytate phosphorus in soybean meal before and after treatment with mold phytase. *Poultry Science*. 47:1842-1848.

NRC. 1998. *Nutrient Requirements of Swine* (10<sup>th</sup> Ed). National Academy Press, Washington, D. C.

Pierce, J.L., K.L. Enright, G.L. Cromwell, L.W. Turner, and T.C. Bridges, 1994. Dietary manipulation to reduce the N and P excretion in finishing pigs. *J. Anim Sci.* 72(Supp 1):33.

Simons, P.C.M., H.A.J. Versteegh, A.W. Jongbloed, P.A. Kemme, P. Slump, K.D. Bos M.G.E. Wolters, R.F. Beudeker and V. Verchoor, 1990. Improvement of phosphorus availability by microbial phytase in broilers and pigs. *Br. J. Nutr.* 64:525-540.

Shreve, B.R., P.A. Moore, T.C. Daniels, D.R. Edwards, and D.M. Miller. 1995. Reduction of P runoff from field applied poultry litter using chemical amendments. *J. Environ. Qual.* 24:106-111.

Smith, D. R., P. A. Moore, Jr., C. L. Griffis, T. C. Daniel, D. R. Edwards, and D. L. Boothe. 2001. Effects of alum and aluminum chloride on phosphorus runoff from swine manure. *J Environ. Qual.* 30:992-998.

Smith , D. R., P. A. Moore, Jr., B. E. Haggard, C. V. Maxwell, T. C. Daniels, K. VanDevander AND M. E. Davis. 1993. Impact of aluminum chloride and dietary phytase on relative ammonia losses from swine manure. J Environ. Qual. In Press.

Water Quality Inventory Report, 1994. State of Arkansas Department of Pollution Control & Ecology

<b>Table.1. Composition of Phase 1 and 2 diets fed to nursery pigs</b>				
	Phytase		Phytase	
	Phase 1		Phase 2	
Ingredients	-	+	-	+
Yellow Corn	36.77	37.36	44.525	45.085
Steamed Rolled Oats	5.00	5.00	0.00	0.00
Lactose	18.00	18.00	10.10	10.10
Optipro™ U.S.	10.25	10.25	0.00	0.00
Soybean Meal, 48%	10.00	10.00	36.00	36.00
Plasma – termin-8	5.00	5.00	0.00	0.00
Select Menhaden Fish Meal	7.00	7.00	1.50	1.50
Soybean Oil	4.00	4.00	0.00	0.00
Fat	0.00	0.00	4.00	4.00
Ethoxyquin	0.03	0.03	0.03	0.03
Lysine – HCl	0.20	0.20	0.16	0.16
Methionine	0.15	0.15	0.10	0.10
Neo-Terramycin	1.00	1.00	0.10	0.10
<b>Mineral Premix (NB-8557B)</b>	<b>0.15</b>	<b>0.15</b>	<b>0.15</b>	<b>0.15</b>
<b>Vitamin Premix (NB-6157B)</b>	<b>0.25</b>	<b>0.25</b>	<b>0.25</b>	<b>0.25</b>
Dicalcium Phosphate	0.65	0.10	1.55	1.00
Calcium Carbonate	0.52	0.45	0.64	0.60
Threonine	0.11	0.11	0.08	0.08
Salt	0.50	0.50	0.50	0.50
Zinc Oxide	0.25	0.25	0.245	0.245
Isoleucine, 85%	0.10	0.10	0.00	0.00
CuSO <sub>4</sub>	0.07	0.07	0.07	0.07
<b>Phytase</b>	<b>0.00</b>	<b>0.03</b>	<b>0.00</b>	<b>0.03</b>
<b>Calculated Composition</b>				
Lysine	1.598	1.599	1.401	1.402
Threonine	1.04	1.04	0.91	0.92
Tryptophan	0.28	0.28	0.271	0.271
Met + Cys	0.92	0.92	0.80	0.80
Ca	0.80	0.65	0.80	0.67
P	0.69	0.59	0.71	0.61
Crude Protein	22.39	22.44	22.04	22.09
Fat	6.80	6.83	6.96	6.98
Lactose	17.82	17.82	10.00	10.00
ME, kcal/lb	1564.51	1573.69	1564.27	1572.98

<b>Table 2. Composition of Phase 1 and 2 diets fed to growing/finishing pigs</b>				
	Phytase		Phytase	
	Phase 1		Phase 2	
Ingredients	-	+	-	+
Yellow Corn	68.325	68.795	72.98	73.47
Soybean meal, 48%	26.60	26.60	20.25	20.25
Fat	2.30	2.30	4.00	4.00
Calcium Carbonate	0.75	0.80	0.77	0.80
Tylosin-40	0.125	0.125	0.05	0.05
Salt	0.50	0.50	0.50	0.50
Lysine HCl	0.15	0.15	0.15	0.15
<b>Mineral Premix (NB-8534)</b>	<b>0.15</b>	<b>0.15</b>	<b>0.15</b>	<b>0.15</b>
<b>Vitamin Premix (NB-6157B)</b>	<b>0.15</b>	<b>0.15</b>	<b>0.15</b>	<b>0.15</b>
Dicalcium Phosphate	0.90	0.35	0.95	0.40
Ethoxyquin	0.03	0.03	0.03	0.03
Threonine	0.02	0.02	0.02	0.02
<b>Phytase</b>	<b>0.00</b>	<b>0.03</b>	<b>0.00</b>	<b>0.03</b>
<b>Calculated Composition</b>				
Lysine	1.099	1.10	0.919	0.92
Threonine	0.71	0.71	0.61	0.61
Tryptophan	0.214	0.214	0.175	0.176
Met + Cys	0.62	0.63	0.55	0.55
Ca	0.60	0.50	0.60	0.49
P	0.54	0.44	0.52	0.42
Crude Protein	18.44	18.48	15.81	15.85
Fat	5.76	5.78	7.45	7.47
Lactose	0.00	0.00	0.00	0.00
ME, kcal/lb	1549.75	1557.52	1581.71	1589.33

<b>Table 3. Composition of Phase 3 and 4 diets fed to growing/finishing pigs</b>				
	Phytase		Phytase	
	Phase 3		Phase 4	
Ingredients	-	+	-	+
Yellow Corn	77.47	77.99	80.425	81.045
Soybean meal, 48%	16.00	16.00	13.20	13.20
Fat	4.00	4.00	4.00	4.00
Calcium Carbonate	0.80	0.80	0.87	0.77
Tylosin-40	0.05	0.05	0.025	0.025
Salt	0.50	0.50	0.50	0.50
Lysine HCl	0.15	0.15	0.15	0.15
<b>Mineral Premix (NB-8534)</b>	<b>0.10</b>	<b>0.10</b>	<b>0.10</b>	<b>0.10</b>
<b>Vitamin Premix (NB-6157B)</b>	<b>0.15</b>	<b>0.15</b>	<b>0.15</b>	<b>0.15</b>
Dicalcium Phosphate	0.75	0.20	0.55	0.00
Ethoxiquin	0.03	0.03	0.03	0.03
<b>Phytase</b>	<b>0.00</b>	<b>0.03</b>	<b>0.00</b>	<b>0.03</b>
<b>Calculated Composition</b>				
Lysine	0.802	0.804	0.725	0.727
Threonine	0.52	0.52	0.48	0.48
Tryptophan	0.150	0.151	0.134	0.134
Met + Cys	0.51	0.51	0.48	0.48
Ca	0.55	0.43	0.52	0.37
P	0.47	0.37	0.42	0.32
Crude Protein	14.15	14.19	13.06	13.11
Fat	7.50	7.52	7.53	7.56
Lactose	0.00	0.00	0.00	0.00
ME, kcal/lb	1585.95	1594.03	1588.89	1598.53

**Table 4. Effect of reduced phosphorus with added phytase on performance of nursery pigs.**

Trait	Diet		SE	P-value
	Normal phosphorus	Reduced phosphorus + phytase		
ADG, g				
Phase 1	284	287	4	.56
Phase 2	542	514	9	.04
Phase 1-2	413	401	5	.13
ADFI, kg				
Phase 1	298	300	4	.65
Phase 2	763	744	10	.16
Phase 1-2	530	522	6	.32
Gain:feed				
Phase 1	.952	.960	.011	.59
Phase 2	.709	.691	.006	.02
Phase 1-2	.778	.769	.005	.18
Weight				
Initial	4.95	4.97	.010	.15
Phase 1	8.92	8.99	.06	.40
Phase 2	16.50	16.19	.15	.16

**Table 5. . Effect of reduced phosphorus diet with added phytase on performance of growing/finishing pigs**

Trait	Diet		SE	P-value
	Normal phosphorus	Reduced phosphorus + phytase		
ADG, g				
Phase 1	783	764	6	.05
Phase 2	993	963	12	.08
Phase 3	884	856	10	.06
Phase 4	738	754	31	.42
Phase 1-4	848	826	6	.025
ADFI, kg				
Phase 1	1.467	1.451	.013	.36
Phase 2	2.364	2.341	.024	.53
Phase 3	2.467	2.429	.029	.37
Phase 4 *	3.273	3.377	.059	.24
Phase 1-4	2.242	2.249	.016	.77
Gain:feed				
Phase 1	.535	.528	.003	.18
Phase 2	.422	.412	.006	.26
Phase 3	.359	.352	.006	.42
Phase 4	.233	.228	.008	.60
Phase 1-4	.379	.368	.004	.04
Weight				
Initial	22.26	22.25	.004	.69
Phase 1	46.32	45.73	.20	.05
Phase 2	68.41	67.12	.26	< .01
Phase 3	93.06	90.94	.43	< .01
Phase 4	107.88	105.73	.64	.02

**Table 6. Phosphorus concentration in holding ponds (mg/L)**

<u>Item</u>	<u>Normal P</u>	<u>Phytase P</u>	<u>% Reduction</u>
Total P	289.7	217.9	24.8
Soluble P	138.4	126.0	8.95

N = 6 samples per manure source



**Table 7. Summary of rainfall and runoff events**

Sample Date	Inches of Rain	Runoff Y or N	Sample Date	Inches of Rain	Runoff Y or N
4/26/2002	0.30	N	12/31/2002	1.50	Y
4/27/2002	0.20	N	2/6/2003	0.20	N
5/2/2002	0.30	N	2/14/2003	0.45	N
5/6/2002	0.35	N	2/18/2003	1.00	N
5/9/2002	0.80	Y	2/22/2003	0.95	N
5/13/2002	2.20	Y	3/13/2003	0.10	N
5/17/2002	1.20	Y	3/19/2003	1.50	N
5/24/2002	1.50	Y	3/20/2003	0.65	N
5/27/2002	0.55	Y	3/27/2003	0.90	N
5/28/2002	1.10	Y	4/6/2003	0.25	N
5/28/2002	0.10	N	4/19/2003	0.10	N
6/5/2002	1.50	Y	4/24/2003	1.10	N
6/9/2002	0.20	N	5/1/2003	0.90	N
6/12/2002	1.00	Y	5/8/2003	0.30	N
6/13/2002	1.00	Y	5/13/2003	1.40	Y
7/2/2002	0.40	Y	5/14/2003	0.15	N
7/4/2002	0.10	N	5/17/2003	1.40	Y
7/12/2002	1.00	Y	5/20/2003	0.65	N
7/13/2002	1.00	Y	5/24/2003	0.50	N
7/29/2002	0.30	N	6/2/2003	2.50	Y
8/10/2002	0.10	N	6/11/2003	0.60	N
8/14/2002	>6.00	Y	6/26/2003	1.20	N
8/25/2002	0.40	N	7/10/2003	1.30	Y
9/19/2002	1.00	Y	7/13/2003	2.70	Y
9/19/2002	0.10	N	7/19/2003	0.10	N
10/9/2002	0.10	N	7/22/2003	1.10	N
10/19/2002	0.30	N	8/2/2003	0.40	N
10/20/2002	0.50	N	8/5/2003	0.20	N
10/25/2002	0.70	N	8/11/2003	0.35	N
10/28/2002	0.80	N	8/29/2003	2.50	N
10/29/2002	1.80	Y	9/1/2003	4.00	N
11/3/2002	1.10	N	9/2/2003	0.40	N
11/5/2002	0.20	N	9/11/2003	1.20	N
11/15/2002	0.10	N	9/12/2003	0.40	N
12/4/2002	1.60	N	9/13/2003	0.30	N
12/5/2002	0.35	N	9/22/2003	0.10	N
12/13/2002	1.80	N	10/3/2003	0.50	N
12/18/2002	0.35	N	10/5/2003	0.15	N
12/24/2002	0.80	N/SNOW			

**Table 8. Total Runoff, L**

- Watershed 1- No Manure- 191,344
- Watershed 2- Phytase- 112,826
- Watershed 3- Normal P- 179,028
- Watershed 4- Phytase+AlCl<sub>3</sub>- 162,418

<b>Table 9. Nutrients applied to soil from manure by treatment (lb/ac)<sup>a</sup></b>			
<b>Treatment</b>	<b>Soluble P</b>	<b>Total P</b>	<b>Total N</b>
<b>1. Unfertilized</b>	<b>n/a</b>	<b>n/a</b>	<b>n/a</b>
<b>2. Phytase Diet</b>	<b>12.7</b>	<b>31.5</b>	<b>230</b>
<b>3. Normal Diet</b>	<b>10.2</b>	<b>30.4</b>	<b>205</b>
<b>4. Phytase + AlCl<sub>3</sub></b>	<b>1.6</b>	<b>26.6</b>	<b>240</b>

<sup>a</sup> Represents three applications over 1.5 years.

<b>Table 10. Soil Test Phosphorus</b>				
<b>Total Phosphorus (0 – 6”), lb/ac</b>				
	<b><u>4-18-02</u></b>	<b><u>8-27-02</u></b>	<b><u>3-13-03</u></b>	<b><u>9-9-03</u></b>
<b>1. No Manure</b>	<b>1032</b>	<b>1046</b>	<b>1056</b>	<b>1010</b>
<b>2. Phytase Manure</b>	<b>960</b>	<b>1048</b>	<b>1146</b>	<b>1276</b>
<b>3. Normal Manure</b>	<b>968</b>	<b>1072</b>	<b>1098</b>	<b>1210</b>
<b>4. Phytase + AlCl<sub>3</sub></b>	<b>902</b>	<b>1004</b>	<b>1444</b>	<b>1224</b>

	<b>0 – 2” Soluble P, mg/kg</b>				<b>0 – 6” Soluble P, mg/kg</b>				<b>0 – 6” Mehlich III, mg/kg</b>			
	<b>4-18-02</b>	<b>8-27-02</b>	<b>3-13-03</b>	<b>9-9-03</b>	<b>4-18-02</b>	<b>8-27-02</b>	<b>3-13-03</b>	<b>9-9-03</b>	<b>4-18-02</b>	<b>8-27-02</b>	<b>3-13-03</b>	<b>9-9-03</b>
<b>1. No Manure</b>	<b>10.04</b>	<b>13.30</b>	<b>11.96</b>	<b>14.30</b>	<b>3.97</b>	<b>7.05</b>	<b>9.65</b>	<b>9.10</b>	<b>48.3</b>	<b>53.8</b>	<b>64.5</b>	<b>60</b>
<b>2. Phytase Manure</b>	<b>8.94</b>	<b>14.25</b>	<b>29.60</b>	<b>25.10</b>	<b>3.91</b>	<b>6.78</b>	<b>16.30</b>	<b>18.00</b>	<b>46.8</b>	<b>59.9</b>	<b>92.8</b>	<b>98.2</b>
<b>3. Normal Manure</b>	<b>10.90</b>	<b>15.65</b>	<b>23.00</b>	<b>25.3</b>	<b>4.41</b>	<b>7.85</b>	<b>10.80</b>	<b>19.95</b>	<b>46.6</b>	<b>59.1</b>	<b>76.1</b>	<b>96.8</b>
<b>4. Phytase + AlCl<sub>3</sub></b>	<b>7.89</b>	<b>14.15</b>	<b>16.00</b>	<b>16.1</b>	<b>3.08</b>	<b>5.63</b>	<b>7.70</b>	<b>13.35</b>	<b>35.3</b>	<b>44.9</b>	<b>58.9</b>	<b>94.2</b>

<b>Treatment</b>	<b>Cu</b>
1. Unfertilized	2.5
2. Phytase Diet	2.3
3. Normal Diet	3.6
4. Phytase + AlCl <sub>3</sub>	3.5

<b>Treatment</b>	<b>Soluble P</b>	<b>Total P</b>	<b>Total N</b>
1. Unfertilized	0.89	1.26	1.84
2. Phytase Diet	0.92 (7.2)	1.12 (3.6)	1.39 (0.6)
3. Normal Diet	1.30 (12.7)	1.65 (5.4)	2.38 (1.2)
4. Phytase + AlCl <sub>3</sub>	0.97 (165)	1.31 (4.9)	2.28 (1.0)

	<u><b>Pounds</b></u>	<u><b>%</b></u>
•Total P delivered in feed	8,222	
•Removed in pigs marketed	2,507	30.5
•P in manure spread	1,616	19.6
•Residual	4,099	49.8

	<u><b>Pounds</b></u>	<u><b>%</b></u>
• Total N delivered in feed	40,839	
• Removed in pigs marketed	11,680	28.60
• N in manure spread	3,655	8.94
• Residual	25,504	62.45

Table 16. Available forage dry matter, estimated forage growth, and estimated forage removal by cattle grazing pastures fertilized with manure from pigs fed a normal P diet or one with reduced P plus phytase<sup>a</sup>.

year	date	Normal P manure	Phytase manure
2002	5/21	5404	4311
	6/14	1754	1683
	est. growth <sup>b</sup>	1067	1582
	est. removal	4716	4210
	12/2	3562	3609
	1/8	3096	1896
	est. growth	388	127
	est. removal	854	1840
2003	4/3	3542	3963
	7/10	3038	2401
	est. growth	3065	4340
	est. removal	3569	5903

<sup>a</sup>All data are expressed in pounds per acre.

<sup>b</sup>Estimated forage growth was the growth that occurred during the grazing period.

Table 17. Estimated P uptake by forage and estimated P removal by cattle grazing pastures fertilized with manure from pigs fed a normal P diet or one with reduced P plus phytase<sup>a</sup>.

item	year	period	Normal P manure	Phytase manure
P-uptake	2002	to 5/21	21.8	16.5
		5/21-6/14	0.5	4.9
		6/14-12/2	4.7	4.6
		12/2-1/8	-0.2	-1.3
		through 1/8/03	26.9	24.7
	2003	1/8-4/3	7.2	12.8
		4/3-7/10	3.8	0.1
		1/8-7/10	11	12.9
P-removal <sup>b</sup>	2002	5/21-6/14	17.1	16.2
		12/2-1/8	2.4	3.9
		through 1/8	19.5	20.1
	2003	4/3-7/10	13.7	11.8

<sup>a</sup>All data are expressed in pounds per acre.

<sup>b</sup>P-removal represents the amount that disappeared from the pasture based on forage disappearance. In reality, this number represents P consumed by the grazing animal and will likely be deposited elsewhere in the pasture.

Table 18. Estimated N uptake by forage and estimated N removal by cattle grazing pastures fertilized with manure from pigs fed a normal P diet or one with reduced P plus phytase<sup>a</sup>.

item	year	period	<b>Normal P</b>	<b>Phytase</b>
			manure	manure
N-uptake	2002	to 5/21	93	74.9
		5/21-6/14	-4.7	16.5
		6/14-12/2	72	72.6
		12/2-1/8	-1.8	-7.3
		through 1/8/03	158.5	156.7
	2003	1/8-4/3	96.2	142
		4/3-7/10	-25.7	-13.1
1/8-7/10		70.5	128.9	
N-removal <sup>b</sup>	2002	5/21-6/14	32.4	49.8
		12/2-1/8	93.4	115
		through 1/8	125.8	164.8
	2003	4/3-7/10	101	130

<sup>a</sup>All data are expressed in pounds per acre.

<sup>b</sup>N-removal represents the amount that disappeared from the pasture based on forage disappearance. In reality, this number represents N consumed by the grazing animal; some will be deposited in animal protein growth and some will likely be deposited elsewhere in the pasture.

Table 19. Gain per acre (lb), and estimated Pand N removal (lb/acre) based on body growth by cattle grazing pastures fertilized with manure from pigs fed a normal P diet or one with reduced P plus phytase.

animal gain/acre		Normal P manure	Phytase manure
2002	spring	264	210
2002	fall	164	92
2002	total	428	302
2003	spring	346	603
2002-03	total	774	905
<b>P removal based on gain/acre<sup>a</sup></b>			
2002	spring	1.5	1.2
2002	fall	1.0	0.5
2002	total	2.5	1.8
2003	spring	2.0	3.5
2002-03	total	4.5	5.3
<b>N removal based on gain/acre<sup>b</sup></b>			
2002	spring	2.5	2.0
2002	fall	1.5	0.9
2002	total	4.0	2.8
2003	spring	3.2	5.7
2002-03	total	7.2	8.5

<sup>a</sup>Calculated assuming that body weight gain is 0.59% P (NRC, 1996).

<sup>b</sup>Calculated assuming that body weight gain is 15% protein and that protein is 6.25% N.



**Figure 1: Diagram of University Of Arkansas Swine Farm showing locations of manure storages and runoff plots**

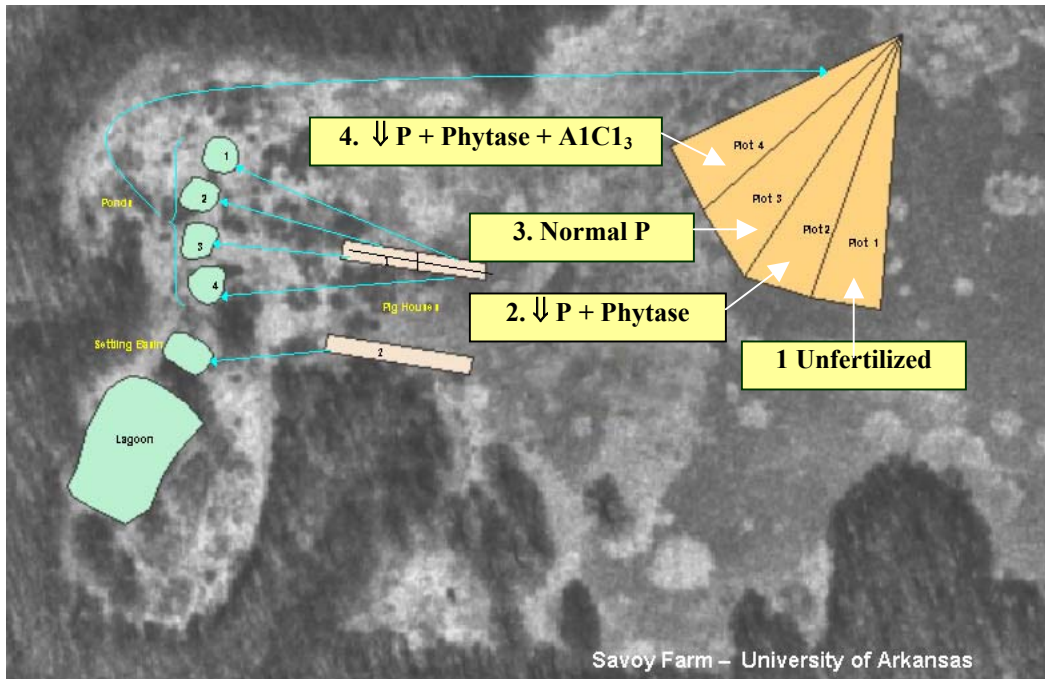

**Figure 2. Small In-field Runoff Collector**

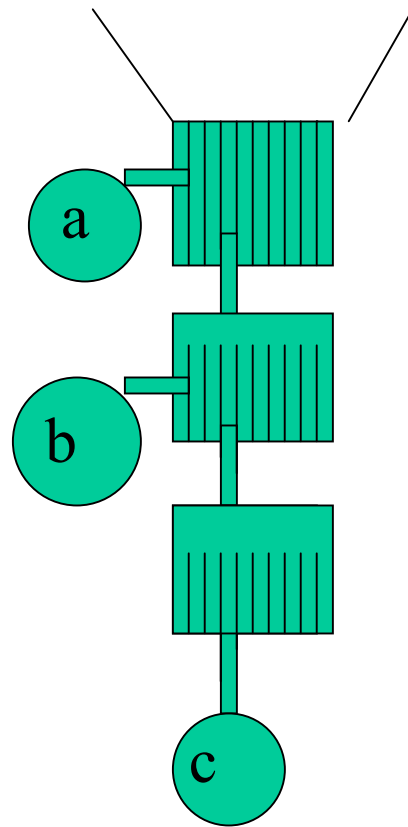

Figure 3: Manure Solids Trends: UA Swine Farm Settling Basin

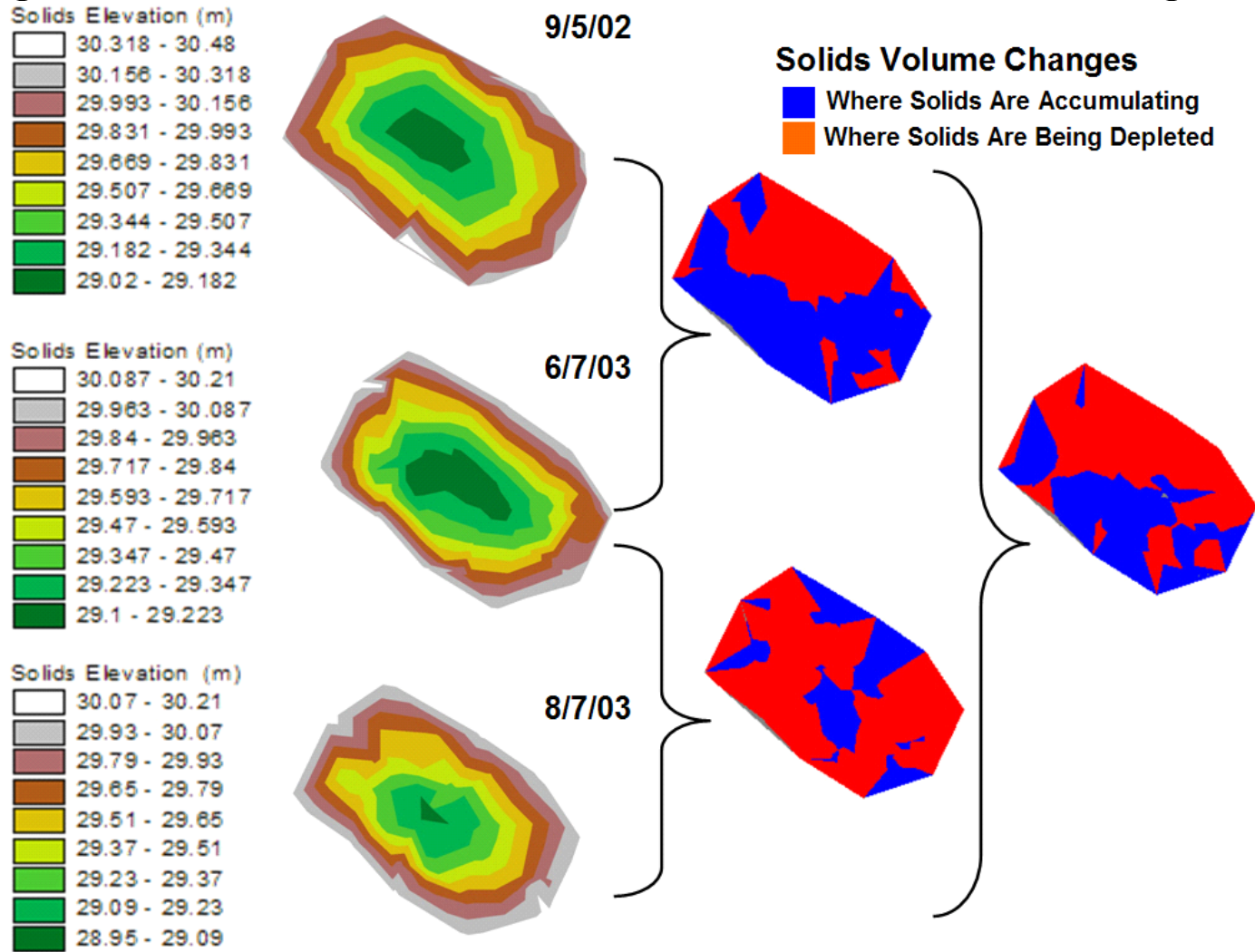

Figure 4: Manure Solids Trends: UA Swine Farm Lagoon

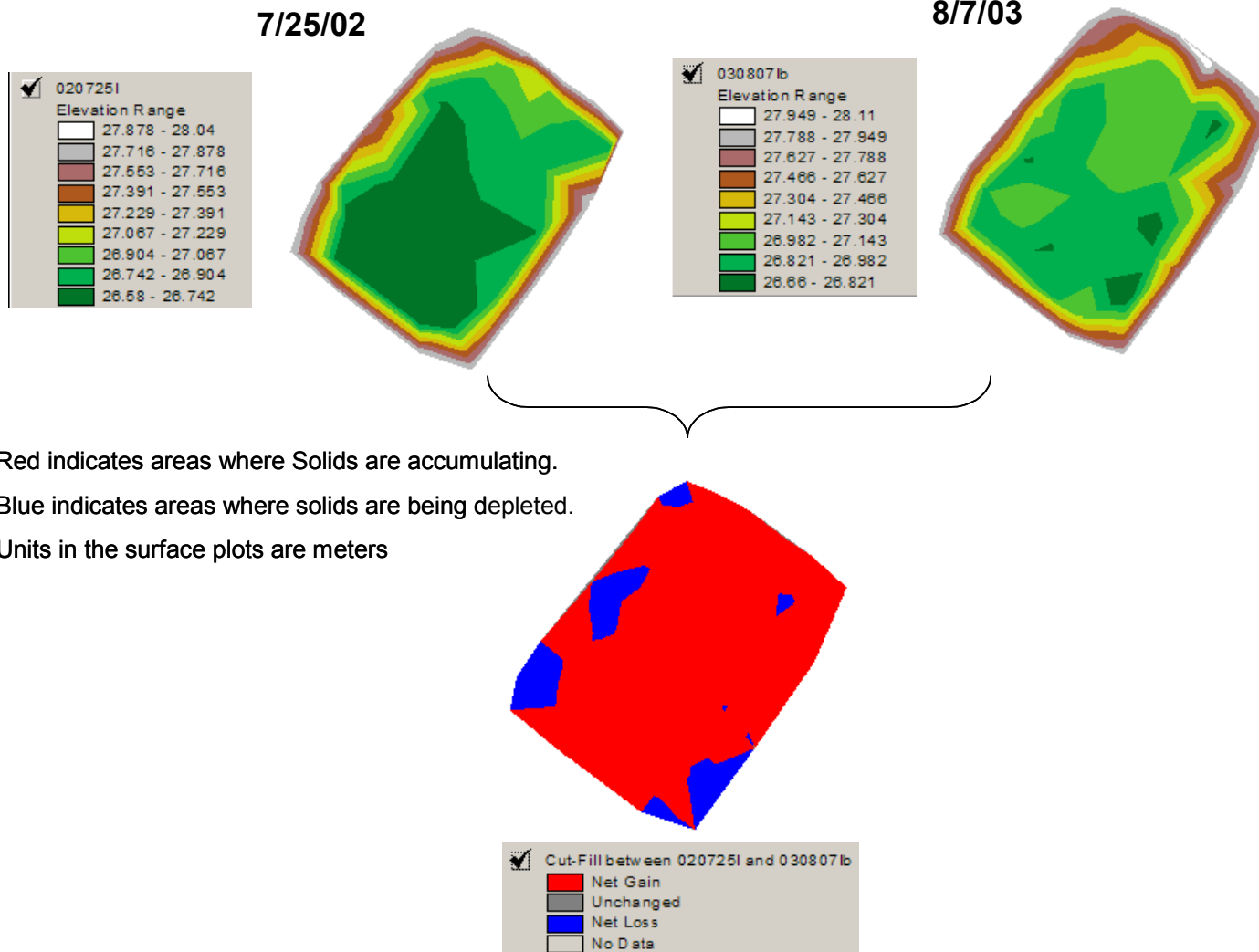
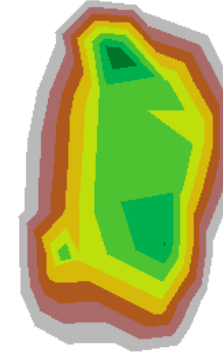
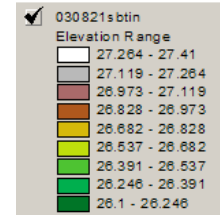
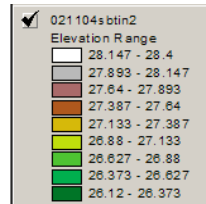

Figure 5: Manure Solids Trends: Townsell Settling Basin

11/4/02

8/21/03



- Red indicates areas where Solids are accumulating.
- Blue indicates areas where solids are being depleted.
- Units in the surface plots are meters

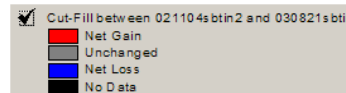
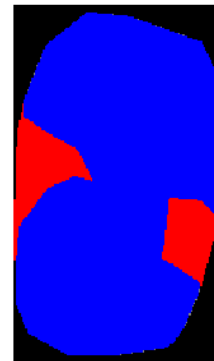

### Figure 6: Manure Solids Trends: Townsell Holding Pond



- Red indicates areas where Solids are accumulating.
- Blue indicates areas where solids are being depleted.
- Units in the surface plots are meters

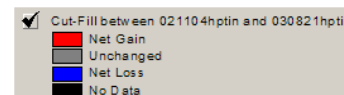
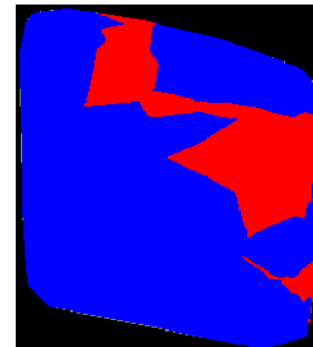

### Figure 7: Manure Solids Trends: Faulkner Settling Basin

**4/9/02**

**8/26/03**

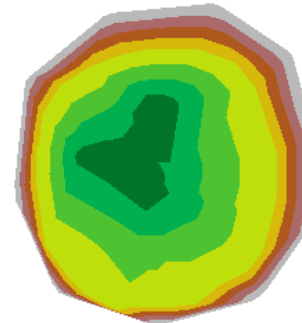
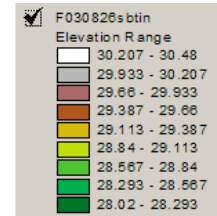
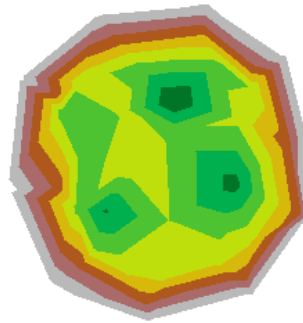
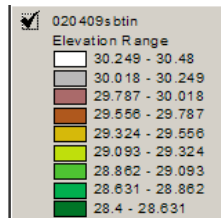

- Red indicates areas where Solids are accumulating.
- Blue indicates areas where solids are being depleted.
- Units in the surface plots are meters

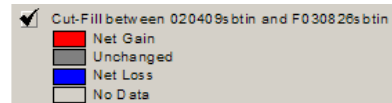
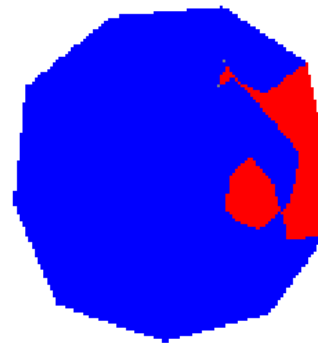

### Figure 8: Manure Solids Trends: Faulkner Holding Pond

**4/9/02**

**8/26/03**

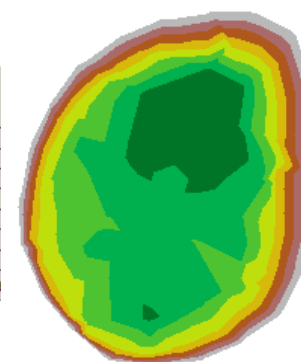
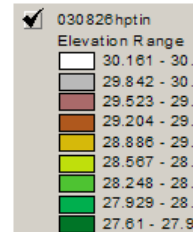
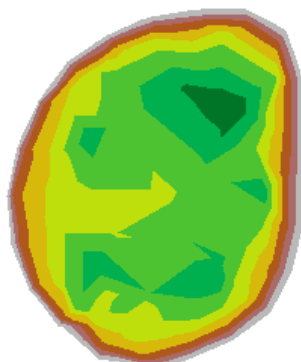
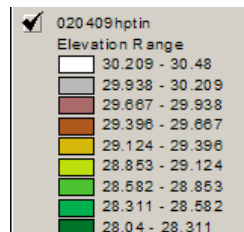

- Red indicates areas where Solids are accumulating.
- Blue indicates areas where solids are being depleted.
- Units in the surface plots are meters

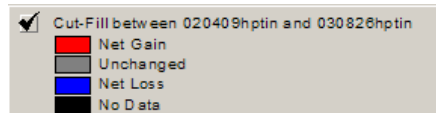



Figure 9: Summary of All Manure Values

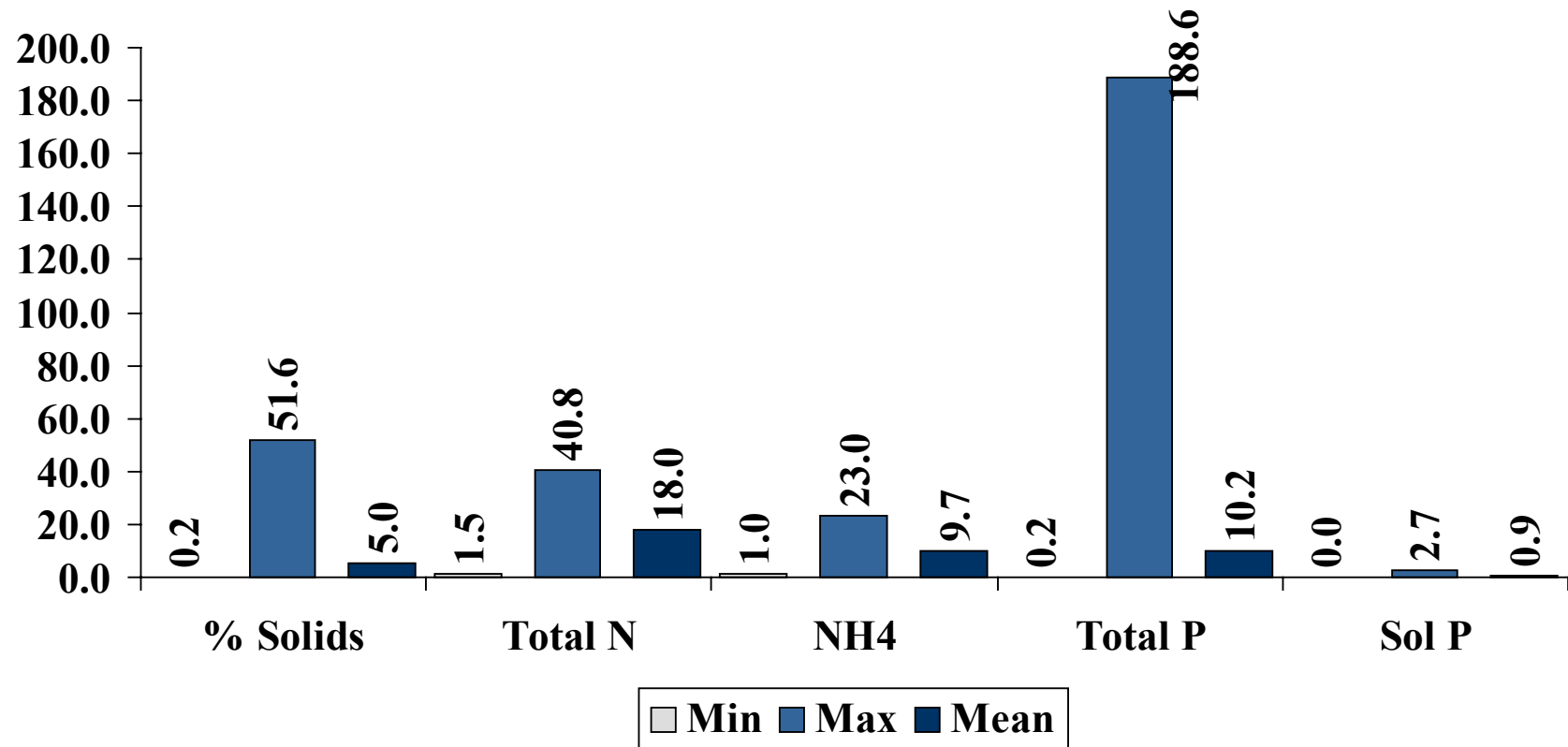

Figure 10: Summary of All Manure Values

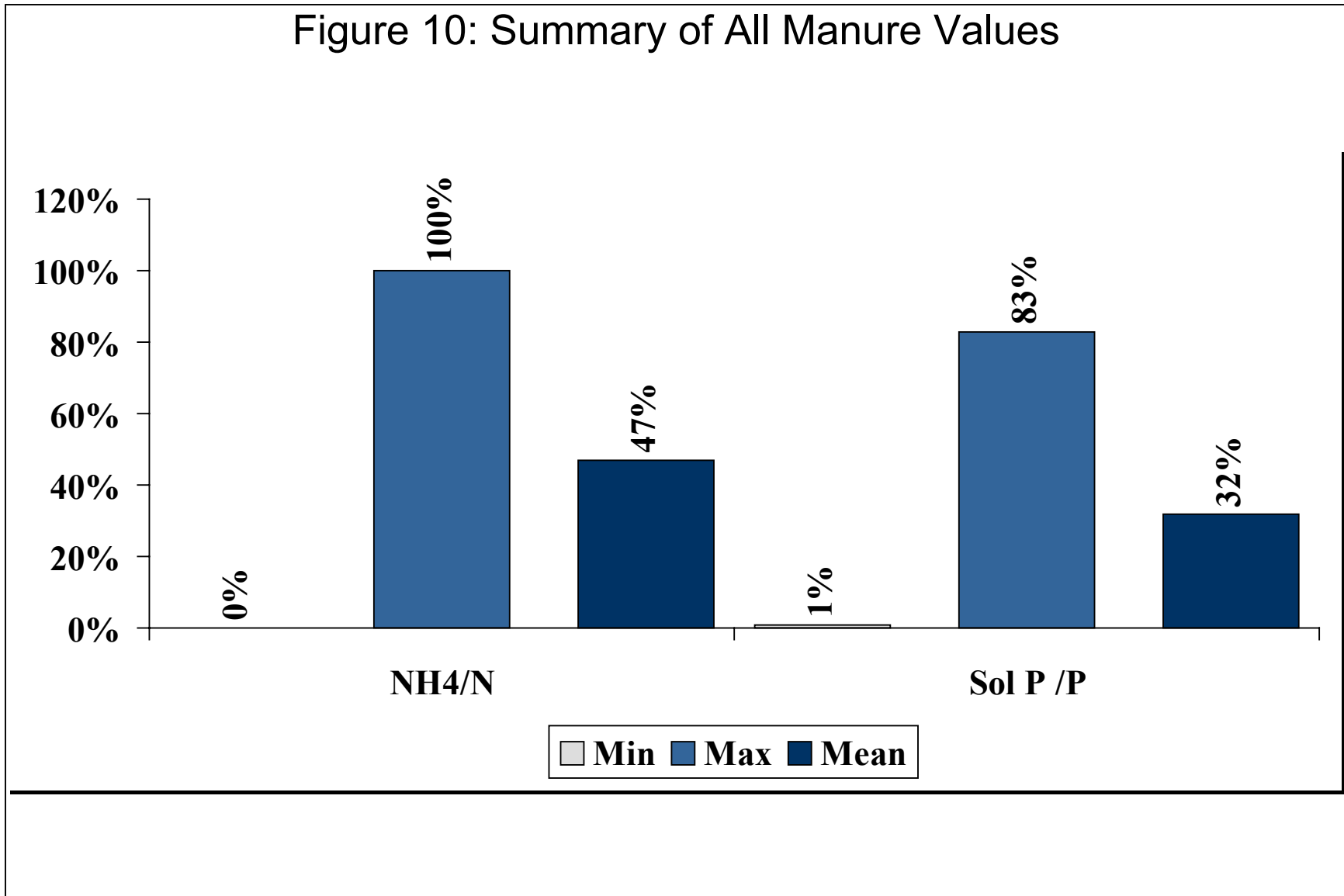

Figure 11: Comparing Two Settling Basin Nutrient Values. Samples collected from the same pond on different dates and therefore had different nutrient values.

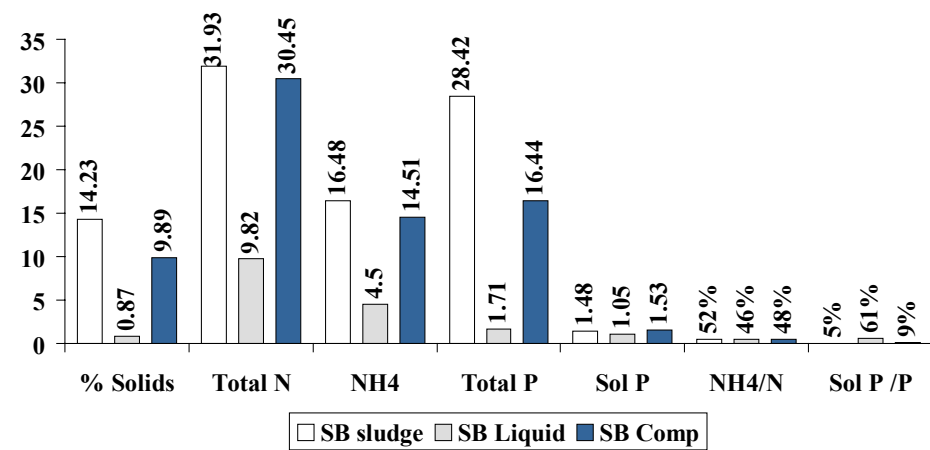
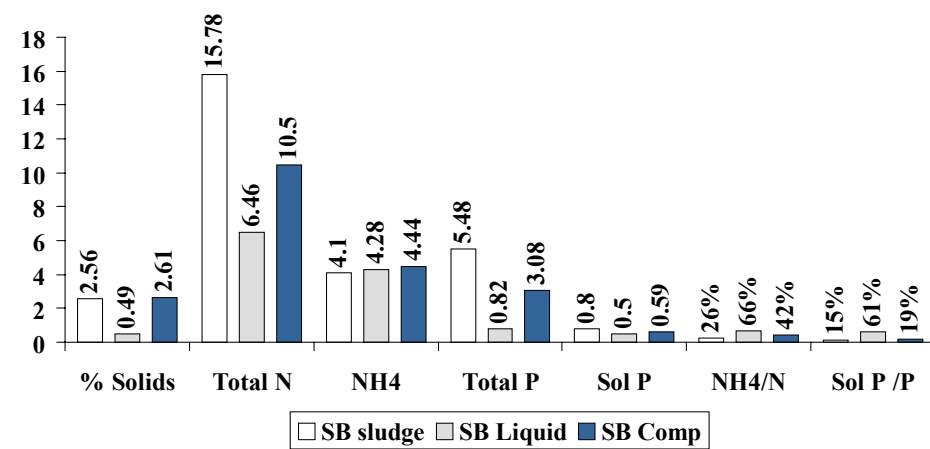

Figure 12: Typical Lagoon Manure Values. This is a single sample that is representative of typical values.

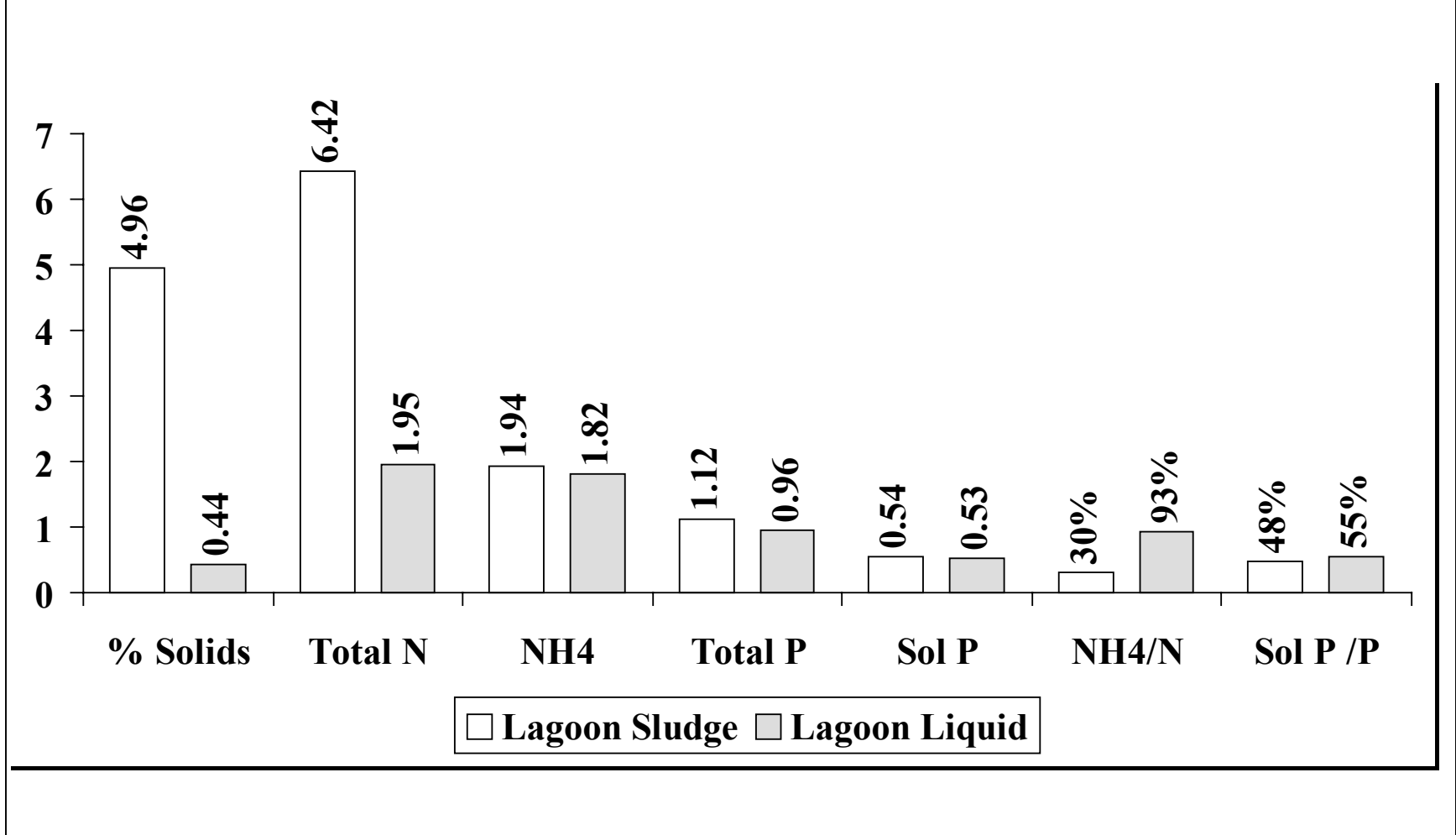
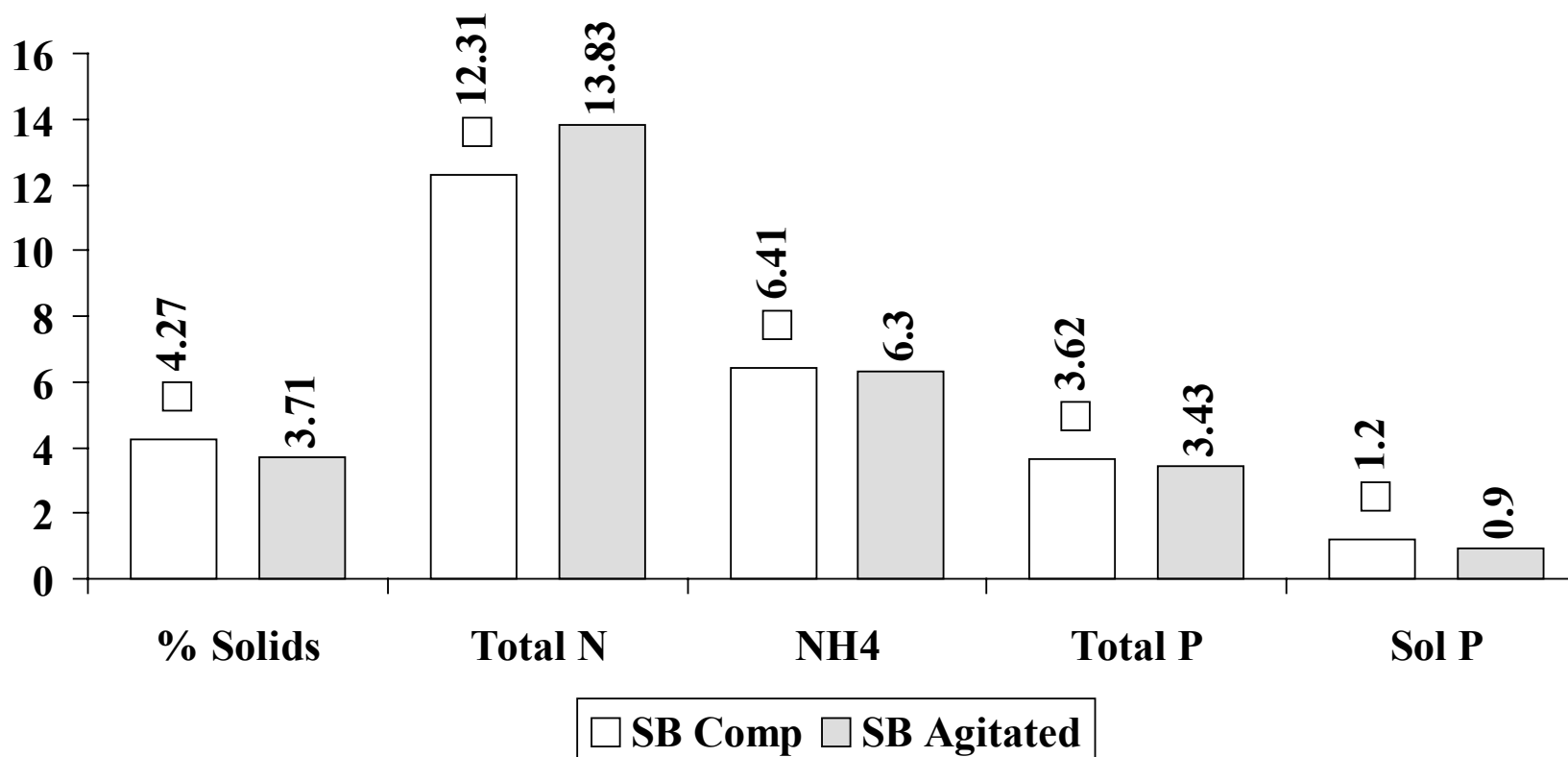
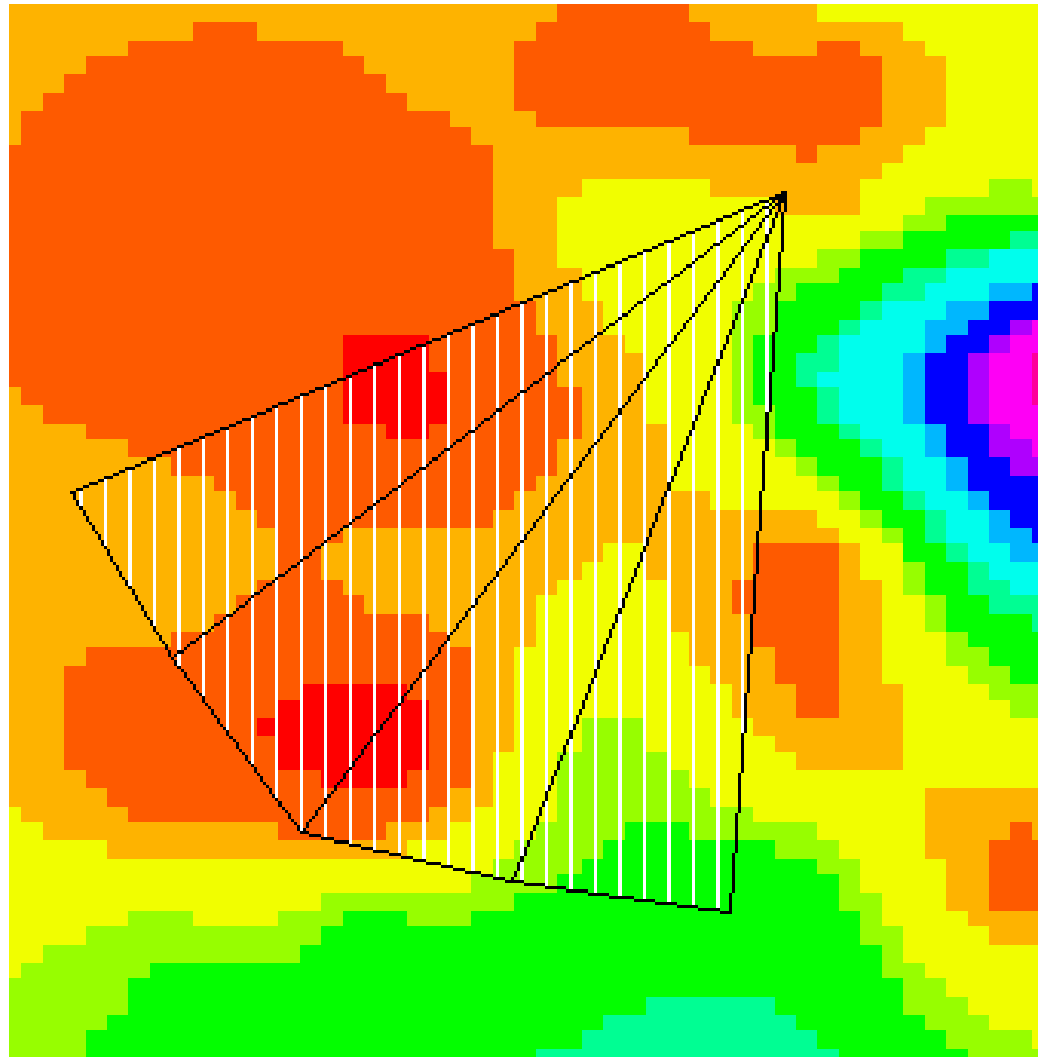
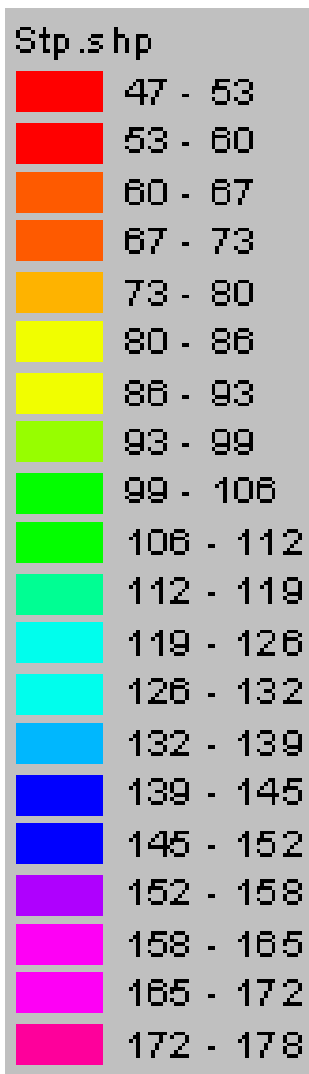

Figure 13: Comparing Composite and Agitated Samples. These two samples were collect from the same settling basin on the same day. The composite sample was collected prior to agitation. The agitated sample was collect after agitation.



# Figure 14. Soil Test P



**Figure 15. Effect of fertilization with manure on soluble and total P runoff from four watersheds.**

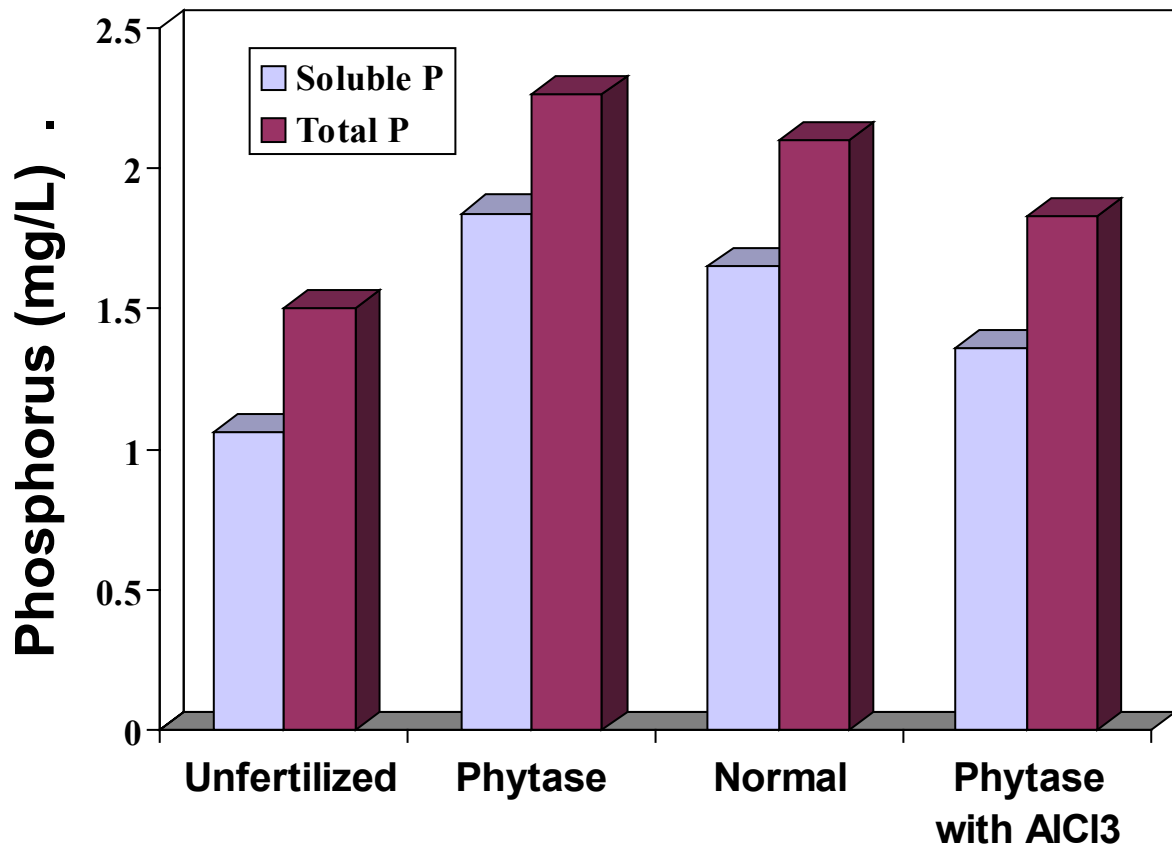

**Figure 16. Effect of manure application on  $\text{NH}_4^+$  and  $\text{NO}_3^-$  concentrations in runoff.**

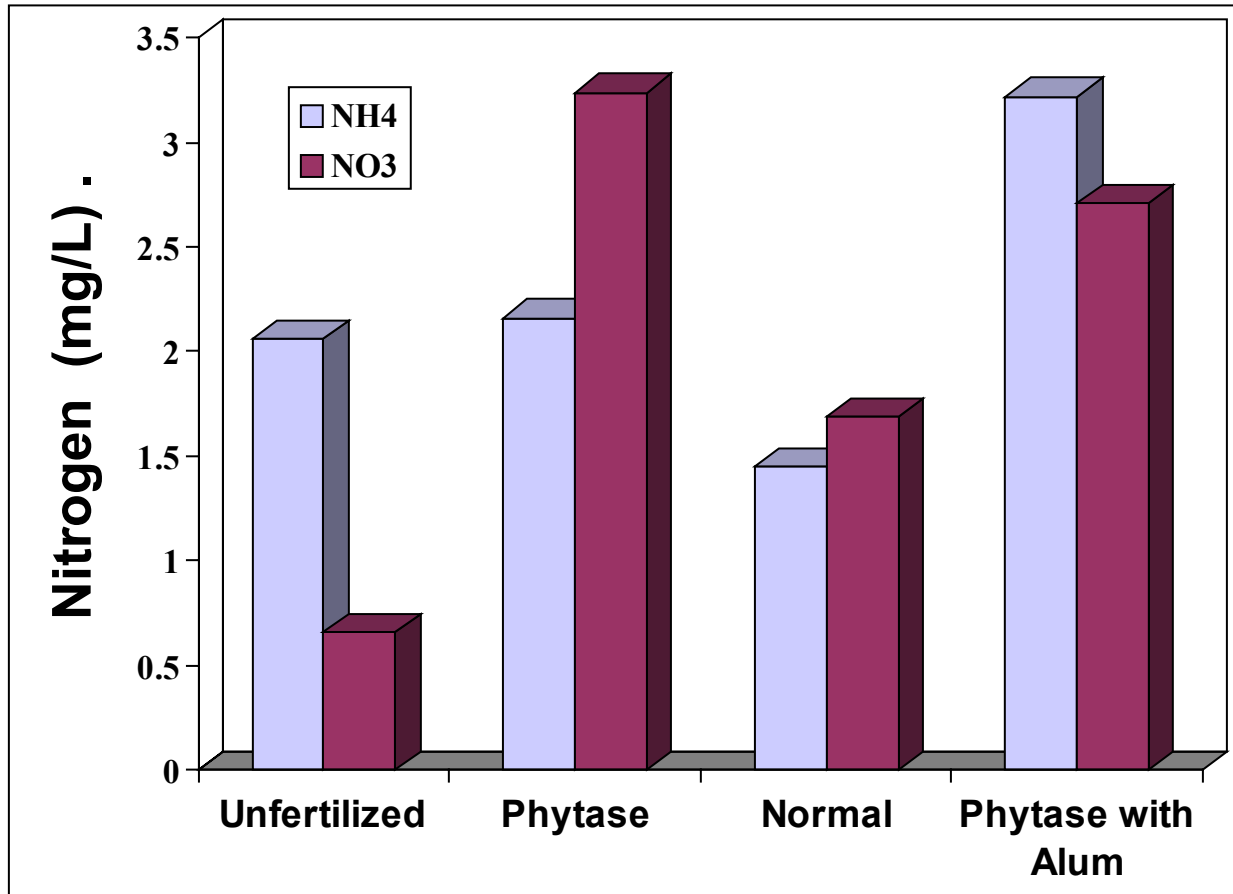



**Figure 17. Effect of manure fertilization on Zinc concentration in runoff**

