

for practical application, opening the path for widespread adoption of the clock-gating technique in low-power design of custom IC's.

REFERENCES

- [1] M. Pedram, "Power minimization in IC design: Principles and applications," *ACM Trans. Design Automation*, vol. 1, no. 1, pp. 3–56, Jan. 1996.
- [2] G. Friedman, "Clock distribution design in VLSI circuits: An overview," in *Proc. IEEE ISCAS*, San Jose, CA, May 1994, pp. 1475–1478.
- [3] E. Tellez, A. Farrah, and M. Sarrafzadeh, "Activity-driven clock design for low power circuits," in *Proc. IEEE ICCAD*, San Jose, CA, Nov. 1995, pp. 62–65.
- [4] M. Alidina and J. Monteiro *et al.*, "Precomputation-based sequential logic optimization for low power," *IEEE Trans. VLSI Syst.*, vol. 2, pp. 426–436, Dec. 1994.
- [5] L. Benini and G. De Micheli, "Symbolic techniques of clock-gating logic for power optimization of control-oriented synchronous networks," in *Proc. European Design Test Conf.*, Paris, France, 1997, pp. 514–520.

A Complete Operational Amplifier Noise Model: Analysis and Measurement of Correlation Coefficient

Jiansheng Xu, Yisong Dai, and Derek Abbott

Abstract—In contrast to the general operational amplifier (op amp) noise model widely used, we propose a more complete and applicable noise model, which considers the correlation between equivalent input voltage noise source e_n and current noise source i_n . Based on the superposition theorem and equivalent circuit noise theory, our formulae for the equivalent input noise spectrum density of an op amp noise are applied to both the inverting and noninverting input terminals. By measurement, we demonstrate that the new expressions are significantly more accurate. In addition, details of the measurement method for our noise model parameters are given. A commercial operational amplifier (Burr-Brown OPA37A) is measured by means of a low-frequency noise power spectrum measuring system and the measured results of its noise model parameters, including the spectral correlation coefficient (SCC), are finally given.

Index Terms—Noise models, operational amplifiers, spectral correlation coefficient.

I. INTRODUCTION

Recently, integrated operational amplifiers (op amps) have been used in more and more practical applications. With the continual improvement of their noise characteristics, they have been commonly found in the design of preamplifier circuits. For this reason, the calculation of the circuit noise of an op amp and its low-noise design are paid more attention than ever. At present, the noise models [1]–[3] of the overwhelming majority of op amps are illustrated as in Fig. 1(a) and (b).

The commonly accepted two-port noise model is in Fig. 1(a). The op amp is considered noiseless and the equivalent voltage noise source e_n

and current noise source i_n are referred back to the input terminals. Fig. 1(b) is commonly adopted when the positive terminal is grounded. To simplify calculation, in some models only e_n is adopted and i_n is neglected [4], [5]. The advantage of these equivalent circuits is simplicity and convenience. However, in the area of small-signal detection, the requirements of noise specifications in the course of calculation and design of a low-noise circuit become higher. The shortcoming of Fig. 1(a) and (b) is obvious: the correlation between voltage noise source e_n and current noise source i_n is not considered, giving rise to inaccuracy.

At present, methods for measuring e_n and i_n [6], [7] use a small value of source resistance to measure an equivalent input voltage noise e_n and use a very large source resistance to measure an equivalent input current noise i_n . Because the correlation is not considered in this method, the measuring method is only an approximate solution. In fact, it can be calculated that the neglect of the correlation item can lead to, at most, a 40% measurement error [7]. Thus, it is commonly believed that the method can give only an approximate solution, and cannot give an accurate solution.

To solve this problem, a more complete op amp noise model is presented in this paper, based on Fig. 1(c), which considers the correlation between e_n and i_n for each input terminal and then the formula of equivalent input noise power spectrum density for the inverting and noninverting input terminals can be derived. With different source resistors, the noise model parameters of an op amp have been measured by means of a low-frequency noise measuring system and the noise model parameters, including the spectral correlation coefficient, are presented.

II. A COMPLETE NOISE MODEL AND ITS EQUIVALENT INPUT NOISE POWER SPECTRUM

In order to improve precision of the noise model, based on Fig. 1(a) and (b), we use one equivalent voltage noise source and one equivalent current noise source at each op amp input terminal in our model. Second, it should be pointed out that the correlation between e_n and i_n at each input terminal should be considered for completeness. Let $\gamma = \gamma_1 + j\gamma_2$ be the spectral correlation coefficient (SCC), given by $\gamma = S_{e_i}(f)/\sqrt{S_e(f)S_i(f)}$, in which $S_e(f)$, $S_i(f)$ are the power spectral densities of the voltage noise e_n and current noise i_n , respectively, and $S_{e_i}(f)$ is the cross-spectral density [8] between e_{n1} and i_{n1} . Also let $\gamma' = \gamma'_1 + j\gamma'_2$ be the SCC between e_{n2} and i_{n2} , in which i_{n1} and i_{n2} are current noises at two input terminals of an op amp. Thus, it can be concluded that there is no correlation between them. Fig. 1(c) is a complete op amp noise model including eight parameters, i.e., e_{n1} , i_{n1} , $\gamma = \gamma_1 + j\gamma_2$, e_{n2} , i_{n2} , and $\gamma' = \gamma'_1 + j\gamma'_2$, each of which varies with frequency. It is obvious that all these parameters cannot be calculated by use of internal noise sources of an op amp, for noise sources in an op amp are so many that it is very difficult to calculate them separately and accurately. However, they can be calculated by measuring equivalent input noise power spectrum with different source resistors. Now the relation between the eight parameters and equivalent input noise power spectrum can be derived as follows.

Let $Z_1 = R_1 + jX_1$, $Z_2 = R_2 + jX_2$ and $Z_f = R_f + jX_f$, $e_1^2 = 4kTR_1$, $e_2^2 = 4kTR_2$, $i_f^2 = 4kT/R_f$, where e_1^2 and e_2^2 are the thermal noise spectrum of resistance R_1 and R_2 , i_f^2 is the current noise spectrum of resistance R_f . According to Fig. 2(a), its equivalent noise circuit can be drawn as in Fig. 2(b).

According to the superposition theorem, the gain of each noise source can be calculated first and then the total output noise can be obtained by addition of each noise source power. Multiplication by the square of the noise bandwidth finally gives the output noise power

Manuscript received June 1, 1998; revised May 20, 1999. This work was supported in part by the China Natural Science Foundation under Contract 69672023. This paper was recommended by Associate Editor K. Halonen.

J. Xu and Y. Dai are with the School of Information Science and Engineering, Jilin University of Technology, Changchun, China 130025.

D. Abbott is with the Centre for Biomedical Engineering (CBME), Electrical and Electronic Engineering Department, the University of Adelaide, Adelaide, SA5005, Australia.

Publisher Item Identifier S 1057-7122(00)02323-0.

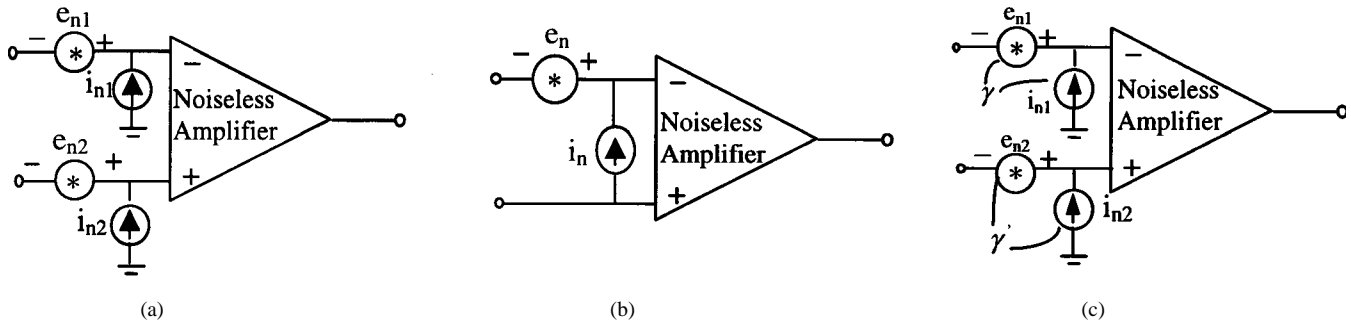

Fig. 1. Equivalent noise models for an op amp.

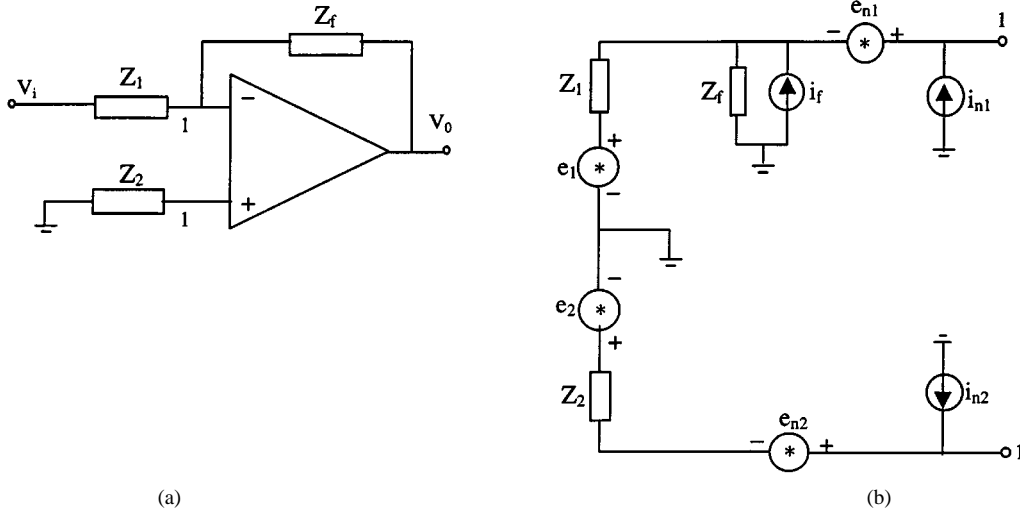

Fig. 2. (a) Inverting input op amp circuit. (b) The equivalent noise circuit of the inverting input op amp.

spectrum. Therefore, from Fig. 2(b), the contribution of inverting input terminal noise sources to the output noise can be expressed as

$$S'_-(f) = e_1^2 \left| \frac{Z_f}{Z_1} \right|^2 + \{e_{n1}^2 + (i_{n1}^2 + i_f^2) |Z_1 // Z_f|^2 + 2e_{n1} i_{n1} \text{Re}[\gamma(Z_1 // Z_f)^*]\} \left| 1 + \frac{Z_f}{Z_1} \right|^2. \quad (1)$$

The contribution of noninverting input terminal noise sources to the output noise could be expressed as

$$S'_+(f) = \{e_{n2}^2 + i_{n2}^2 |Z_2|^2 + e_2^2 + 2e_{n2} i_{n2} \text{Re}[\gamma' Z_2^*]\} \cdot \left| 1 + \frac{Z_f}{Z_1} \right|^2. \quad (2)$$

Therefore, the total output noises contributed by the two input terminals are

$$S_0(f) = S'_-(f) + S'_+(f). \quad (3)$$

The expressions of total output noise referred to inverting input terminal and noninverting input terminal can be expressed as follows. The equivalent noise power spectrum of inverting input terminal is

$$S_-(f) = \frac{S_0(f)}{\left| \frac{Z_f}{Z_1} \right|^2} = e_1^2 + \{e_{n1}^2 + (i_{n1}^2 + i_f^2) |Z_1 // Z_f|^2 + 2e_{n1} i_{n1} \text{Re}[\gamma(Z_1 // Z_f)^*]\} \left| 1 + \frac{Z_1}{Z_f} \right|^2 + \{e_{n2}^2 + i_{n2}^2 |Z_2|^2 + e_2^2 + 2e_{n2} i_{n2} \text{Re}[\gamma' Z_2^*]\} \left| 1 + \frac{Z_1}{Z_f} \right|^2. \quad (4)$$

The equivalent noise power spectrum of noninverting input terminal is

$$S_+(f) = \frac{S_0(f)}{\left| 1 + \frac{Z_f}{Z_1} \right|^2} = \frac{e_1^2}{\left| 1 + \frac{Z_1}{Z_f} \right|^2} + \{e_{n1}^2 + (i_{n1}^2 + i_f^2) |Z_1 // Z_f|^2 + 2e_{n1} i_{n1} \text{Re}[\gamma(Z_1 // Z_f)^*]\} + \{e_{n2}^2 + i_{n2}^2 |Z_2|^2 + e_2^2 + 2e_{n2} i_{n2} \text{Re}[\gamma' Z_2^*]\}. \quad (5)$$

Now let us discuss (4) and (5). If the correlation between e_{n1} and i_{n1} , e_{n2} , and i_{n2} is neglected, then (4) can be simplified as

$$S_-(f) = e_1^2 + \{e_{n1}^2 + e_{n2}^2 + e_2^2\} \left| 1 + \frac{Z_1}{Z_f} \right|^2 + (i_{n1}^2 + i_f^2) |Z_1|^2 + i_{n2}^2 |Z_2|^2 \left| 1 + \frac{Z_1}{Z_f} \right|^2. \quad (6)$$

When $Z_1 = R_1$, $Z_2 = R_2$, $Z_f = R_f$, (6) is equal to [7, p. 59, (3-17)], which means that (4) is more general. Under the same conditions, (5) can be simplified as

$$S_+(f) = \frac{e_1^2}{\left| 1 + \frac{Z_1}{Z_f} \right|^2} + \{e_{n1}^2 + e_{n2}^2 + e_2^2 + i_{n2}^2 |Z_2|^2 + (i_{n1}^2 + i_f^2) |Z_1 // Z_f|^2\}. \quad (7)$$

According to the same conditions, (7) is equal to [7, p. 60, (3-18)], which means that (5) is also more general.

In addition, from (4) and (5) it can be theoretically concluded that the equivalent voltage noise sources e_{n1} and e_{n2} cannot be calculated

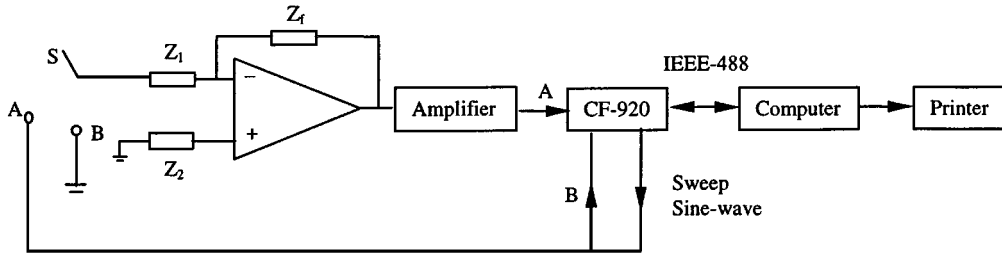

Fig. 3. The measurement system block diagram.

separately. Therefore, for calculation convenience, it is supposed that e_{n1} is equal in magnitude to e_{n2} . Hence, let $e_n^2 = e_{n1}^2 + e_{n2}^2$. Then (4) and (5) can be changed to

$$S_-(f) = e_1^2 + \{e_n^2 + (i_{n1}^2 + i_f^2)|Z_1//Z_f|^2 + \sqrt{2}e_n i_{n1} \text{Re}[\gamma(Z_1//Z_f)^*] + i_{n2}^2|Z_2|^2 + e_2^2 + \sqrt{2}e_n i_{n2} \text{Re}[\gamma'Z_2^*]\} \left|1 + \frac{Z_1}{Z_f}\right|^2 \quad (8)$$

$$S_+(f) = \frac{e_1^2}{\left|1 + \frac{Z_1}{Z_f}\right|^2} + e_n^2 + (i_{n1}^2 + i_f^2)|Z_1//Z_f|^2 + \sqrt{2}e_n i_{n1} \text{Re}[\gamma(Z_1//Z_f)^*] + i_{n2}^2|Z_2|^2 + e_2^2 + \sqrt{2}e_n i_{n2} \text{Re}[\gamma'Z_2^*]. \quad (9)$$

It should be noted that $S_+(f)$ and $S_-(f)$ are different because the two input terminal voltage gains are different.

III. MEASUREMENT SYSTEM AND MEASUREMENT METHOD

Fig. 3 is the measurement system block diagram. In order to refer the measured output noise to the input terminals, it is necessary to have measured the frequency response $A(f)$ of the op amp and measuring system. Therefore switch S is at A first. Then the switch S is at B to measure the output noise power spectrum of an op amp.

We measure the output noise power spectrum $S_o(f)$ by means of an FFT spectrum analyzer (model: CF-920), then the equivalent input noise power spectrum is given by

$$S_i(f) = \frac{S_o(f)}{A^2(f)}$$

where $A(f)$ is the gain of measurement system, including the gain $A_1(f)$ of amplifier measured and the measuring system gain $A_2(f)$, namely, $A(f) = A_1(f)A_2(f)$. In this system the cross-spectrum estimation method is used to reduce preamplifier noise contribution because the noise of the two preamplifiers are uncorrelated (powered by different batteries) and their cross-spectrum value is very small and, as a consequence, a small noise value ($nV/\sqrt{\text{Hz}}$) can be measured. The cross-spectrum estimation is measured in the frequency range of 1 Hz–100 kHz. The measuring process and data processing are automated by computer. The measurement software is chiefly made up of two parts: 1) the IEEE-488 interface to control the CF-920 and 2) the data processing parameter calculation from the measured results and display programs.

In order to accurately measure equivalent input noise spectrum, $A(f)$ is obtained by measuring the swept sine wave response.

TABLE I
THE VALUES OF R_1 , R_f AND THE SPECTRAL DENSITY

R_1 (Ω)	R_f (k Ω)	$S_i(f)$
200	4	$S_1(f)$
150	3	$S_2(f)$
100	2	$S_3(f)$

TABLE II
THE VALUES OF R_1 , R_2 , R_f , AND THE SPECTRAL DENSITY

R_1 (Ω)	R_2 (Ω)	R_f (k Ω)	$S(f)$
100	100	2	$S_4(f)$
100	200	2	$S_5(f)$

Simultaneously, in this measurement system 512 spectral averages are performed to maintain the high precision of spectrum estimation. The measured results have shown that the accuracy of measuring system is superior to 4% [9].

The measuring method is as follows. According to (4) and (5), it is seen that the equivalent noise power spectrum of inverting or noninverting input terminals can be measured by varying source impedances and then the noise model parameters can be calculated accurately. The calculation formulae are derived as follows.

A. Inverting Input Terminal

- 1) Let $X_1 = X_2 = X_f = 0$, $R_2 = 0$, then (8) changes into

$$S_-(f) = e_1^2 + e_n^2 \left(1 + \frac{R_1}{R_f}\right)^2 + (i_{n1}^2 + i_f^2)R_1^2 + \sqrt{2}e_n i_{n1} \gamma_1 R_1 \left(1 + \frac{R_1}{R_f}\right). \quad (10)$$

The values of three different resistors R_1 and R_f are shown in Table I. The equivalent input noise power spectra of three source resistances are measured, respectively, and the results are as follows (where $K = R_f/R_1$):

$$i_{n1}^2 = \frac{1}{R_1 R_2 - R_2 R_3} \cdot \left[\frac{S_1(f)R_2 - S_2(f)R_1}{R_1 - R_2} - \frac{S_2(f)R_3 - S_3(f)R_2}{R_2 - R_3} \right] \quad (11)$$

$$e_n^2 = \left[i_{n1}^2 R_1 R_2 - \frac{S_1(f)R_2 - S_2(f)R_1}{R_1 - R_2} \right] / \left(1 + \frac{1}{K}\right)^2 \quad (12)$$

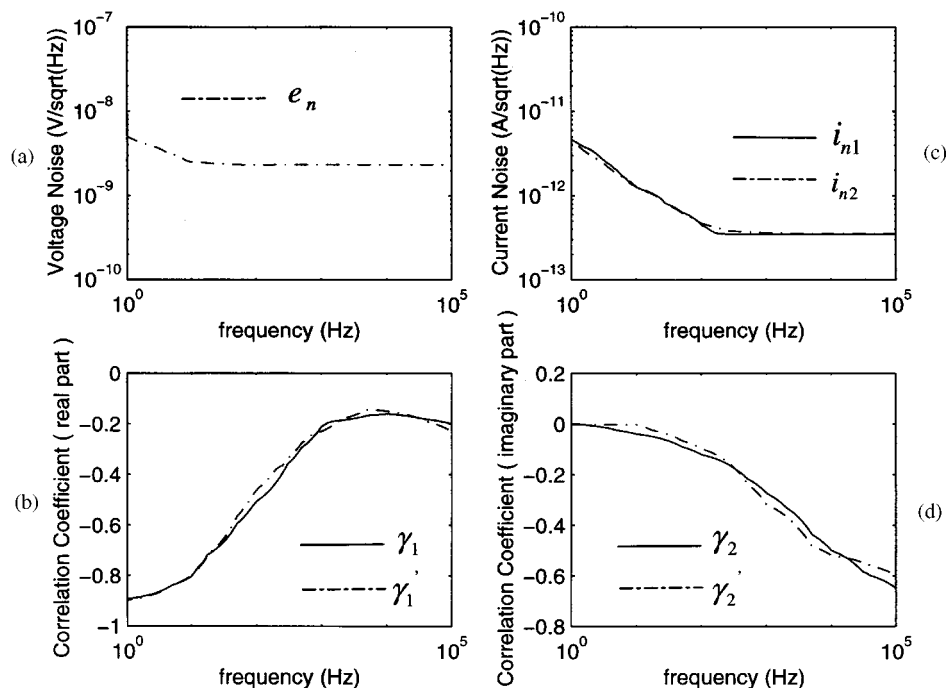

Fig. 4. The measured results of an op amp. (a) Equivalent input voltage noise e_n versus frequency. (b) Equivalent input current noise i_{n1} and i_{n2} versus frequency. (c) Real part of SCC γ_1 and γ_1' versus frequency. (d) Imaginary part of SCC γ_2 and γ_2' versus frequency.

TABLE III
COMPARISON BETWEEN OUR MEASURED VALUES AND TYPICAL DATASHEET
VALUES AT 3 SPOT FREQUENCIES (nV/\sqrt{Hz})

Voltage noise	10 Hz	30 Hz	1 kHz
Typical value	3.1	2.9	2.7
Measured value	2.5	2.4	2.4
Error	24%	20.8%	12.5%

$$\gamma_1 = \frac{1}{\sqrt{2}e_n i_{n1} R_1 \left(1 + \frac{1}{K}\right)} \cdot \left[S_1(f) - 4\kappa T R_1 - e_n^2 \left(1 + \frac{1}{K}\right)^2 - (i_{n1}^2 + i_f^2) R_1^2 \right]. \quad (13)$$

- 2) Let $X_2 = X_f = R_2 = 0$, $R_f = 2k \Omega$, $C_1 = 4 \mu F$, $R_1 = 100 \Omega$, the corresponding equivalent input noise power can be measured and the expression is obtained as

$$S_-(f) = 4\kappa T R_1 + \frac{[X_1^2 + (R_1 + R_f)^2]}{R_f^2} \cdot e_n^2 + (i_{n1}^2 + i_f^2)(R_1^2 + X_1^2) + \sqrt{2}e_n i_{n1} \frac{\gamma_1 [R_1(R_1 + R_f) + X_1^2]}{R_f^2} + \sqrt{2}e_n i_{n1} \gamma_2 X_1. \quad (14)$$

Then, γ_2 can be calculated as

$$\gamma_2 = \left\{ S_-(f) - 4\kappa T R_1 - \frac{[X_1^2 + (R_1 + R_f)^2]}{R_f^2} \cdot e_n^2 - (i_{n1}^2 + i_f^2)(R_1^2 + X_1^2) - \sqrt{2}e_n i_{n1} \frac{\gamma_1 [R_1(R_1 + R_f) + X_1^2]}{R_f^2} \right\} / \sqrt{2}e_n i_{n1} X_1. \quad (15)$$

- 3) For the case of $X_1 = X_2 = X_f = 0$, $R_1 = 100 \Omega$, $R_f = 2k \Omega$, then it leads to

$$S_-(f) = e_1^2 + e_n^2 \left(1 + \frac{R_1}{R_f}\right)^2 + (i_{n1}^2 + i_f^2) R_1^2 + \sqrt{2}e_n i_{n1} R_1 \gamma_1 \left(1 + \frac{R_1}{R_f}\right) + [i_{n2}^2 R_2^2 + e_2^2 + \sqrt{2}e_n i_{n2} R_2 \gamma_1'] \left(1 + \frac{R_1}{R_f}\right)^2. \quad (16)$$

Let

$$S(f) = S_-(f) - e_1^2 - e_n^2 \left(1 + \frac{R_1}{R_f}\right)^2 - (i_{n1}^2 + i_f^2) R_1^2 - \sqrt{2}e_n i_{n1} R_1 \gamma_1 \left(1 + \frac{R_1}{R_f}\right). \quad (17)$$

When source resistance R_2 varies with Table II, the equivalent input noise power spectra can be measured, respectively, and then we can obtain

$$i_{n2}^2 = \frac{S_4(f) R_5 - S_5(f) R_4}{\left(1 + \frac{1}{K}\right)^2 R_4 R_5 (R_4 - R_5)} \quad (18)$$

$$\gamma_1' = \frac{1}{\sqrt{2}e_n i_{n2} R_4} \left[\frac{S_4(f)}{\left(1 + \frac{1}{K}\right)^2} - i_{n2}^2 R_4^2 - 4\kappa T R_4 \right]. \quad (19)$$

- 4) For the case of $X_1 = X_f = 0$, then we have

$$S_-(f) = e_1^2 + e_n^2 \left(1 + \frac{R_1}{R_f}\right)^2 + (i_{n1}^2 + i_f^2) \cdot R_1^2 + \sqrt{2}e_n i_{n1} R_1 \gamma_1 \left(1 + \frac{R_1}{R_f}\right) + [i_{n2}^2 (R_2^2 + X^2) + 4\kappa T R + \sqrt{2}e_n i_{n2} \cdot (R \gamma_1' + X \gamma_2')] \left(1 + \frac{R_1}{R_f}\right)^2 \quad (20)$$

TABLE IV
COMPARISONS BETWEEN OUR MEASURED VALUE AND TYPICAL DATASHEET
VALUES AT THREE SPOT FREQUENCIES (pA/\sqrt{Hz})

Current noise	10 Hz	30 Hz	1 kHz
Typical value	1.7	1.0	0.4
Measured value	1.4	0.85	0.35
Error	21.4%	17.6%	14.3%

where

$$\begin{aligned} R_1 &= 100 \Omega; \\ R_f &= 2 \text{ k}\Omega; \\ R_2 &= 100 \Omega; \\ C_2 &= 4 \mu\text{F}; \\ R &= \frac{R_2}{1 + \omega^2 R_2^2 C_2^2} \\ X &= \frac{\omega R_2^2 C_2}{1 + \omega^2 R_2^2 C_2^2}. \end{aligned}$$

According to the noise power spectrum of the measured equivalent input $S_-(f)$, then we can have

$$\begin{aligned} \gamma'_2 &= \frac{1}{\sqrt{2}e_n i_{n2} X} \\ &\cdot \left\{ \left[S_-(f) - e_1^2 - e_n^2 \left(1 + \frac{R_1}{R_f} \right)^2 - (i_{n1}^2 + i_f^2) \right. \right. \\ &\quad \cdot \left. \left. R_1^2 - \sqrt{2}e_n i_{n1} R_1 \gamma_1 \left(1 + \frac{R_1}{R_f} \right) \right] \right\} / \left(1 + \frac{R_1}{R_f} \right)^2 \\ &\quad - \left[i_{n2}^2 (R^2 + X^2) + 4\kappa T R + \sqrt{2}e_n i_{n2} R \gamma'_1 \right]. \end{aligned} \quad (21)$$

In this way, all the noise model parameters ($e_n, i_{n1}, \gamma = \gamma_1 + j\gamma_2, i_{n2}$, and $\gamma' = \gamma'_1 + j\gamma'_2$) of an op amp can be obtained by means of measuring the equivalent input noise power spectrum with varying source resistance.

B. Noninverting Input Terminal

In the same way, for the case of the noninverting input terminal, all the noise model parameters can be also calculated with varying source impedance. For brevity, the formulae are not given here.

IV. THE MEASURED RESULTS

By use of the method and the measuring system above, a commercial op amp (OPA37A) has been measured and the results are shown in Fig. 4.

From Fig. 4(a) and (b) it can be seen that when the correlations between e_{n1} and i_{n1} , e_{n2} , and i_{n2} are neglected, then the measured results of both e_n and i_n are larger than the values when the correlation are considered. Thus, an overestimate results when the widely used method to measure e_n and i_n is carried out, where correlation is neglected and only noise contributions of a small source resistance and a large source resistance are considered in the course of noise model parameter calculation. Our measured results also show that the correlation between e_{n1} and i_{n1} , e_{n2} , and i_{n2} do exist, especially in low frequency. When $1/f$ noise dominates, the correlation coefficients between e_{n1} and i_{n1} , e_{n2} , and i_{n2} become bigger. From Table III and IV (typical values can be found in the Burr-Brown datasheet) it can be seen that in low-frequency region the errors are bigger than those in the high-frequency region, which in another way demonstrates that the correlation does exist in the low frequency region and is stronger

than that of high-frequency region. If the correlation is neglected, then the errors in the low-frequency region become bigger. In addition, the results also show that the noise model and measurement method proposed in this paper can improve measurement and calculation precision in low-noise circuit design.

V. CONCLUSION

According to the analysis and measured results, the following conclusions can be reached.

- 1) In contrast to the noise model commonly used at present, a complete noise model and its measurement method for an op amp are proposed in the paper. Because contributions of all noise sources to output noise and the correlation between e_{n1} and i_{n1} , e_{n2} , and i_{n2} are considered adequately, the noise model parameters can be obtained accurately through this way.
- 2) The formulae of complete equivalent noise power spectra for inverting input and noninverting input terminals are derived, in which the contributions of all noise sources to output terminal and correlative coefficients between them are included.
- 3) The main advantage of this method is that all internal parameters of an op amp do not need to be known in advance for noise model parameter calculations. And the experimental results are in good agreement with theoretical analysis.

ACKNOWLEDGMENT

The authors wish to thank the associated editor and reviewers for a number of suggestions.

REFERENCES

- [1] D. F. Stout, *Handbook of Operational Amplifier Circuit Design*. New York: McGraw-Hill, 1976, pp. 45–51.
- [2] J. R. Hufault, *Operational Amplifiers Network Design*. New York: Wiley, 1986, pp. 36–48.
- [3] G. B. Clayton and B. W. G. Newby, *Operational Amplifiers*, B. H. Newnes, Ed., 1992, ch. 2–3.
- [4] G. Espinosa *et al.*, "Noise performance of OTA-C circuits," in *Proc. IEEE/ISCAS*, San Jose, CA, 1988, pp. 2173–2176.
- [5] P. Bowron and K. A. Mezher, "Noise analysis of second-order analog active filters," *Proc. Inst. Elect. Eng.*, vol. 141, no. 5, pp. 350–356, Oct. 1994.
- [6] J. G. Graeme *et al.*, *Operational Amplifiers: Design and Applications*. New York: McGraw-Hill, 1971, pp. 492–493.
- [7] C. D. Motchenbacher and J. A. Connelly, *Low Noise Electronic System Design*. New York: Wiley, 1993.
- [8] J. Xu, Y. Dai, and Y. Li, "The study of the relation between R_n - G_n noise model and E_n - I_n noise model of an amplifier," *IEEE Trans. Circuits Syst. I*, vol. 45, pp. 154–156, Feb. 1998.
- [9] Y. Dai, "Performance analysis of cross-spectral density estimation and its application," *Int. J. Electron.*, vol. 71, no. 1, pp. 45–53, 1991.