

PUBLISHED VERSION

Davis, Bruce R.; Abbott, Derek; Parrondo, J. M. R..

Thermodynamic energy exchange in a moving plate capacitor, *Chaos*, 2001; 11 (3):747-754.

© 2001 American Institute of Physics. This article may be downloaded for personal use only. Any other use requires prior permission of the author and the American Institute of Physics.

The following article appeared in *Chaos* **11**, 747 (2001) and may be found at <http://link.aip.org/link/doi/10.1063/1.1394191>

PERMISSIONS

http://www.aip.org/pubservs/web_posting_guidelines.html

The American Institute of Physics (AIP) grants to the author(s) of papers submitted to or published in one of the AIP journals or AIP Conference Proceedings the right to post and update the article on the Internet with the following specifications.

On the authors' and employers' webpages:

- There are no format restrictions; files prepared and/or formatted by AIP or its vendors (e.g., the PDF, PostScript, or HTML article files published in the online journals and proceedings) may be used for this purpose. If a fee is charged for any use, AIP permission must be obtained.
- An appropriate copyright notice must be included along with the full citation for the published paper and a Web link to AIP's official online version of the abstract.

31st March 2011

<http://hdl.handle.net/2440/2323>

Thermodynamic energy exchange in a moving plate capacitor

B. R. Davis

Department of Electrical and Electronic Engineering, University of Adelaide, South Australia 5005, Australia

D. Abbott

Department of Electrical and Electronic Engineering, University of Adelaide, South Australia 5005, Australia and Centre for Biomedical Engineering (CBME), University of Adelaide, South Australia 5005, Australia

J. M. R. Parrondo

Department of Fisica Atomica, Nuclear y Molecular, Universidad Complutense de Madrid, 28040 Madrid, Spain

(Received 21 December 2000; accepted 7 June 2001; published 31 August 2001)

In this paper we describe an apparent paradox concerning a moving plate capacitor driven by thermal noise from a resistor. The plates are attracted together, but a demon restores the plates of the capacitor to their original position when the voltage across the capacitor is small—hence only small forces are present for the demon to work against. The demon has to work harder than this to avoid the situation of perpetual motion, but the open question is how? This is unsolved, however we explore the concept of a moving plate capacitor by examining the case where it is still excited by thermal noise, but where the restoring force on the capacitor plates is provided by a simple spring rather than some unknown demon. We display simulation results with interesting behavior, particularly where the capacitor plates collide with each other. © 2001 American Institute of Physics. [DOI: 10.1063/1.1394191]

We consider open problems in the modeling of a noisy moving plate capacitor from the thermodynamic and fluctuational viewpoint. This is of interest to microelectromechanical systems, such as in the modeling of the behavior of a microaccelerometer, and is also of general interest to the modeling of fluctuating systems.

I. THE MOVING PLATE CAPACITOR AND THE DEMON

Consider a capacitor C connected in parallel to a resistor R at a temperature T . The time average force of attraction between the plates of the capacitor is given by

$$\langle f \rangle = -\frac{1}{2} \langle V^2 \rangle \frac{dC}{dx} = \frac{\epsilon A \langle V^2 \rangle}{2x^2} = \frac{\langle q^2 \rangle}{2\epsilon A}, \quad (1)$$

where x is the variable distance between the plates and A is the plate area. We know that $\langle V^2 \rangle = kT/C = kTx/\epsilon A$ and therefore

$$\langle f \rangle = \frac{kT}{2x}. \quad (2)$$

If we allow the plates to freely move together from $x = x_1$ to $x = x_2$, the mechanical work done by the electrostatic forces is

$$W = \int_{x_2}^{x_1} \langle f \rangle dx = \frac{1}{2} kT \ln \left(\frac{x_1}{x_2} \right). \quad (3)$$

Now let us use a demon to determine when the voltage across the capacitor is zero ($V=0$) and at that instant we restore the plates to their original position. There is no force between the plates, so they can be restored to their original

position without doing any work. Clearly, so that we do not violate the laws of thermodynamics, the demon *must* do work equal to or greater than W in Eq. (3). The open question is where and how exactly is this work done. Can the work of Szilard,¹ for instance, be used to explain this?

Even if the voltage is not exactly zero, as long as it is small enough, the work done in restoring the plates to their initial position will be negligible, and the “paradox” remains. Any practical circuit that detects when $V \approx 0$, such as a level-crossing detector, must be powered and hence this power must be the source of W . But the question remains as to the mechanism of how this exact amount of energy (or greater) is guaranteed to be dissipated. Note that the force is proportional to the square of the voltage, similar to the situation in Penfield’s paradox² where the torque of a motor was related to the square of the current.

The dependence of the force on the square of either the voltage or the charge is an interesting situation since the fluctuations create a net force of attraction. The capacitor then acts as a rectifier of thermal fluctuations which is the aspect that we will focus on in this paper. Moreover, it is related to the old “adiabatic piston problem”^{3,4} in which two gases with different densities and temperatures, but the same pressure, are separated by an adiabatic wall. The gases are in equilibrium from the point of view of classical thermodynamics, but it is known that the fluctuations push the piston to the cold side. The adiabatic piston problem is perhaps more involved than the present one, since the piston acts as a heat conductor. Nevertheless, the two problems are related, because in both cases the system is in equilibrium from the point of view of thermodynamics, but evolves due to fluctuations. The capacitor paradox is useful in the study of this

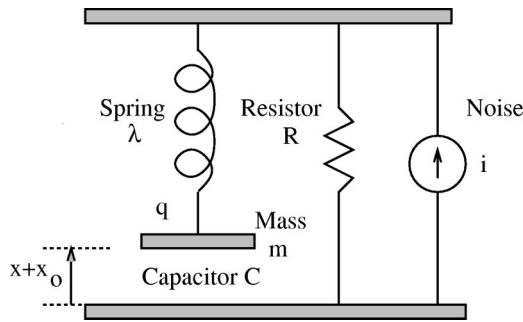

FIG. 1. Capacitor, mass, and spring system.

problem because this effect is achieved without the use of adiabatic constraints.

Note that when references are made to “paradoxes” or “demons,” in this paper, these are merely *heuristic devices* used to highlight *incompleteness* in the present modeling of the system. The open question is to find the *simplest* description that completes the model, so that no apparent violations occur. This is of importance for increasing our understanding of the modeling of fluctuating systems.

II. CAPACITOR WITH A SPRING

In order to gain further appreciation of this problem, we decided to consider a similar system in order to better understand the interaction between the electrical and mechanical parts. Due to the nature of the force law, this interaction is nonlinear. Rather than applying the restoring force via some unknown means, we chose the simplest system possible, which is to have one plate fixed and the other moving plate of mass m attached to a spring of spring constant λ . The spring now provides a restoring force to the plate. As before a resistor R is connected in parallel with the capacitor to provide a source of thermal energy, and $i(t)$ is the thermal noise due to R with power spectral density $S_{ii}(f) = 2kT/R$. To simplify matters we assume the capacitor is in a vacuum. The electrical circuit could also include a series inductance, but this makes the circuit more complex and its omission does not make the model invalid. The arrangement is shown in Fig. 1.

This problem then becomes very interesting as it is fully electromechanical and has application in microelectromechanical systems. For example, it is known that in micromachined devices thermal noise in the mechanical domain (i.e., Brownian motion of the moving parts) becomes critical at these small scales.⁵ Although our Fig. 1 resulted from purely academic inquiry of a fluctuational and thermodynamic problem, it turns out that it corresponds to the equivalent circuit of a microaccelerometer.⁶

In our case, the mechanical system is undamped except for its coupling to the electrical system. Due to the thermal noise voltage across the capacitor generated by the resistor R , a random force is applied to the mechanical system.

While there are difficulties in establishing the dynamical equations for nonlinear systems,⁷ in this case the source of the fluctuations (the resistor R) is linear. Hence the relevant

equations in terms of the capacitor charge q , the plate distance fluctuation x , and the plate velocity $u = dx/dt$ are

$$\frac{dq(t)}{dt} = -\frac{q(t)}{RC(x)} + i(t), \quad (4)$$

$$\frac{dx(t)}{dt} = u(t), \quad (5)$$

$$\frac{du(t)}{dt} = -\frac{\lambda}{m}x(t) - \frac{f(q)}{m}, \quad (6)$$

$$C(x) = \frac{\epsilon A}{x + x_0}, \quad (7)$$

$$f(q) = \frac{q^2}{2\epsilon A}. \quad (8)$$

Here we have defined x_0 as the distance the plates are apart when the spring force is zero, and x is the deviation from this value.

A mechanical damper was not included because the mechanical system is damped by its coupling to the electrical system, and in addition to providing a force $f = du$ proportional to the velocity u , a damper has associated with it a thermal noise force generator of power spectral density $S_{ff}(f) = 2kTd$ and this would obscure the interaction between the electrical and mechanical parts of the system. The penalty paid from a simulation point of view is that the mechanical system is only lightly damped, and it takes a long time to reach equilibrium conditions.

The equations (and the related Fokker–Planck equation in Sec. III) are intractable analytically, so numerical simulations were used. Unfortunately the system is such that it takes a very long time to reach statistical equilibrium, so the simulation results are only an indication of the system behavior.

The solution of stochastic differential equations is not as straightforward as for nonstochastic equations.⁸ However, Runge–Kutta methods still work for such equations, although the accuracy is not as high as the order of the method might imply for nonstochastic equations. In general, for a step size h , an accuracy of better than $O\{h^{1.5}\}$ cannot be obtained (e.g., see Mannella in Ref. 9). Because the coefficient of the stochastic term $i(t)$ does not depend on the system state, there is no difference between Ito or Stratonovich calculus.

In the simulation a demon was not used, the object being solely to investigate the energy transfer between the electrical and mechanical systems. The parameters were arbitrarily chosen so that the RC circuit had a 3 dB bandwidth of 2×10^5 rad/s and the mechanical system was resonant at 10^5 rad/s, a frequency within the noise bandwidth of the RC circuit. For a system in thermal equilibrium with independent degrees of freedom, the energy in each of the degrees of freedom would be expected to be $\frac{1}{2}kT$. For small perturbations of the capacitor plate, the mean square values of q , x , and $u = dx/dt$ would be

$$\hat{\sigma}_q^2 = kTC_0, \quad \hat{\sigma}_x^2 = \frac{kT}{\lambda}, \quad \hat{\sigma}_u^2 = \frac{kT}{m}, \quad (9)$$

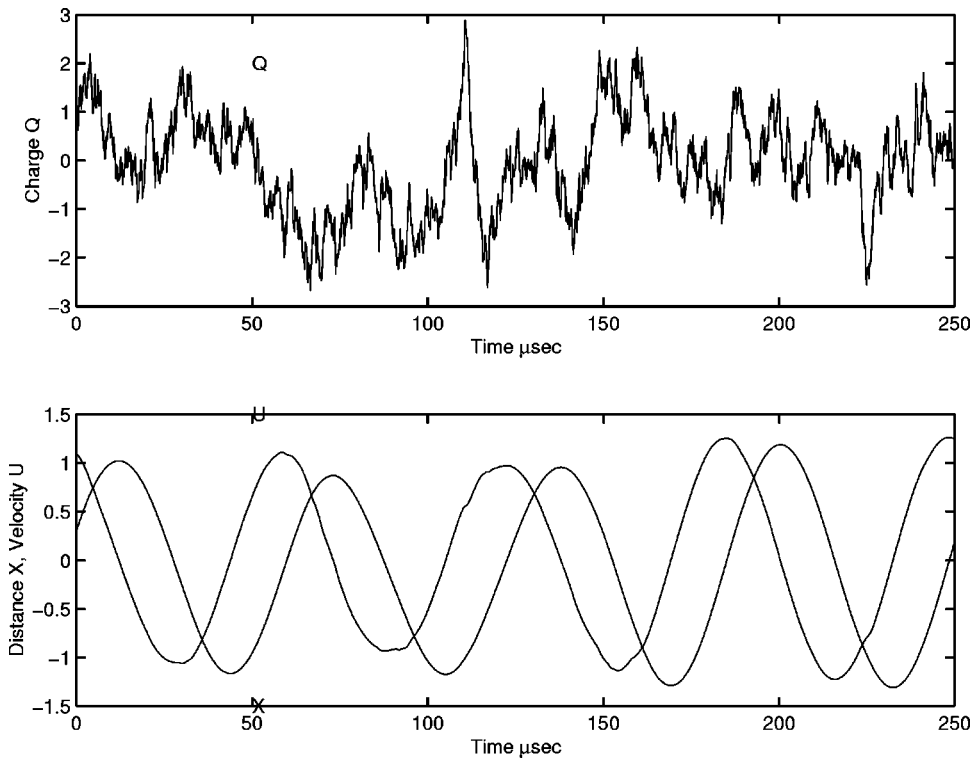

FIG. 2. Simulation results for small perturbations.

where $C_0 = \epsilon A / x_0$.

The carets are used to designate that these may not be the true values, as will be discussed later.

The parameters were initially chosen with $\hat{\sigma}_x = 0.2 x_0$ so that the excursions of the capacitor plate were small compared with the plate spacing. With arbitrary choices of $x_0 = 0.1$ mm and $C_0 = 50$ pF, the other parameters are then all determined. The values are

$$kT = 4.0 \times 10^{-21} \text{ J},$$

$$x_0 = 0.1 \text{ mm},$$

$$C_0 = 50 \text{ pF},$$

$$R = 1.0 \times 10^5 \text{ } \Omega,$$

$$\lambda = 1.0 \times 10^{-11} \text{ N/m},$$

$$m = 1.0 \times 10^{-21} \text{ kg}.$$

The mechanical system is oscillatory with a frequency of 10^5 rad/s and although it seems that the mechanical circuit is undamped, there is a damping effect due to the interaction with the electrical circuit. The damping mechanism is somewhat obscure, and is related to the nonlinear nature of the force law.

In the steady state, the average value of x will not be zero since the average force due to the noise voltage on the capacitor will cause the spring to extend slightly. This extension \bar{x} is given by forming the ensemble average of Eq. (6) and solving for the displacement \bar{x} . This gives

$$m \frac{d\bar{u}}{dt} = -\lambda \bar{x} - \frac{\bar{q}^2}{2\epsilon A}, \tag{10}$$

$$0 \approx \lambda \bar{x} + \frac{kT}{2(\bar{x} + x_0)}, \tag{11}$$

$$\bar{x} \approx \frac{1}{2} \{ -x_0 + \sqrt{x_0^2 - 2\hat{\sigma}_x^2} \}, \tag{12}$$

$$= -2.04 \times 10^{-6} \text{ m}, \tag{13}$$

where the approximation involves approximating \bar{q}^2 by the value expected for a constant plate spacing $\bar{x} + x_0$. (The other solution to the quadratic equation is an unstable equilibrium point). The approximation might be expected to be valid if \bar{x} and $\hat{\sigma}_x$ are both $\ll x_0$. However, it is interesting to note that the approximate equation has no solution if $x_0^2 \leq 2\hat{\sigma}_x^2$.

It can also be observed from Eq. (10) that since $\bar{x} \geq -x_0$ then $\bar{q}^2 \leq 2\epsilon A \lambda x_0$, which implies \bar{q}^2 is finite. However, as discussed later, Eq. (6) [from which Eq. (10) is derived] is incomplete when collisions of the capacitor plates occur, so under those conditions the result will not be true.

For simulation purposes, Eq. (6) was written in terms of normalized variables $Q = q / \hat{\sigma}_q$, $X = x / \hat{\sigma}_x$ and $U = u / \hat{\sigma}_u$, where $\hat{\sigma}_q$, $\hat{\sigma}_x$ and $\hat{\sigma}_u$ are defined by Eq. (9). A fourth-order Runge-Kutta integration was used with a normalized step size of $h = 0.01$.

Figure 2 shows simulation results when the system had reached an apparent steady state after about 10 ms.

The plates have an initial spacing $X_0 = x_0 / \hat{\sigma}_x = 5$, so \bar{X} from Eq. (13) is -0.102 . For the time interval shown, the mechanical variables X and U evolved only slowly due to the lack of mechanical damping, so the values are not necessar-

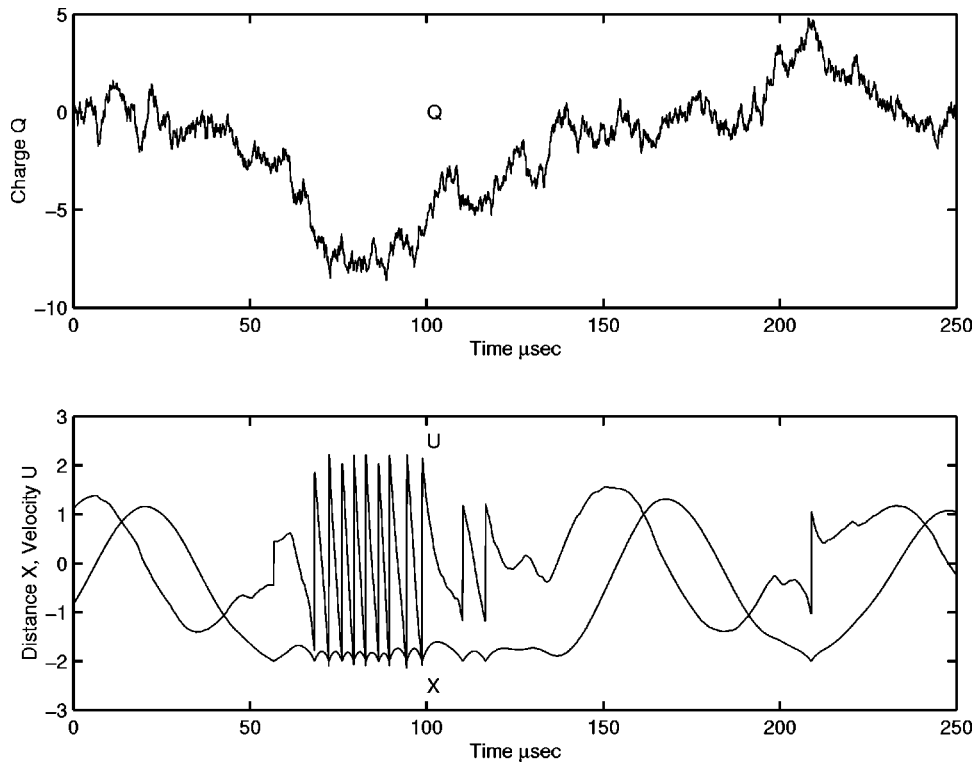

FIG. 3. Simulation results for large perturbations (q unaltered).

ily representative of the average values. However the time average mean and variances calculated over the last 5 ms of a 10 ms simulation were

$$\begin{aligned} \langle Q \rangle &= -0.076, & \sigma_Q^2 &= 0.968, \\ \langle X \rangle &= -0.098, & \sigma_X^2 &= 0.866, \\ \langle U \rangle &= -0.003, & \sigma_U^2 &= 0.853. \end{aligned}$$

As might be expected, the oscillations in the mechanical system are lightly damped with period $2\pi\sqrt{m/\lambda}$ s.

If the capacitor plate was fixed, for this simulation time the 95% confidence limits for σ_Q^2 would be approximately $0.88 \leq \sigma_Q^2 \leq 1.13$ and for small perturbations the result might be expected to be similar. The confidence limits for σ_X^2 and σ_U^2 are difficult to estimate, but are considerably wider than those for σ_Q^2 because of the slow evolution of X and U (due to the lack of damping). However we note that the variances are all close to the predicted values of unity, and $\langle X \rangle$ is close to its predicted value of -0.102 .

With $\hat{\sigma}_x = 0.2x_0$, the plates of the capacitor remain separated for most of the time and no collisions between the plates were observed in the simulation. However if $\hat{\sigma}_x$ is increased, it was found that the plates collided regularly. In the simulation these collisions were assumed elastic so that there is no energy loss. However it is not clear what should happen to q . If the plates are shorted together, the charge q might be expected to go to zero. On the other hand, if there is assumed to be an infinitesimally thin insulating sheet between the plates, then q would remain unaltered. Since the capacitor voltage is zero at this point, there does not seem to be any energy implications in setting $q=0$, but clearly the system will evolve differently in time. Shorting the plates together is an “infinite capacitor–zero resistor” type

problem¹⁰ and the solution is not obvious. Arcing due to the high electric field would not occur in a vacuum.

Figure 3 shows simulation results after 10 ms for the same system as before, except that λ and m were reduced by a factor of 6.25, which increased the value of $\hat{\sigma}_x$ to $0.5x_0$. The charge q was not altered at the collision point. The simulation results show the plates colliding regularly when $X = -X_0$. In this case $X_0 = 2.0$ and $\bar{X} = -0.293$ from Eq. (12).

In the time interval shown, a “chattering” effect was observed in which multiple collisions occurred rapidly. This is due to the fact that when the plates collide, the charge Q can become large (due to the fact that the voltage across the capacitor is near zero, so no charge is lost through the resistor). The plates bounce apart, but if the force of attraction exceeds the spring force, then the plates collide again a short time later.

In this case the time average means and variances over an interval of 5.0 ms were

$$\begin{aligned} \langle Q \rangle &= -0.258, & \sigma_Q^2 &= 3.013, \\ \langle X \rangle &= -0.284, & \sigma_X^2 &= 0.903, \\ \langle U \rangle &= -0.004, & \sigma_U^2 &= 0.891. \end{aligned}$$

The main points to note are that $\langle X \rangle$ was close to its predicted value and the variances of X and U were close to unity, but the variance of Q was significantly greater than unity. When elastic collisions between the plates occur at times t_i determined by $x + x_0 = 0$, Eq. (6) becomes

$$\frac{du(t)}{dt} = -\frac{\lambda}{m}x(t) - \frac{q^2(t)}{2\epsilon Am} - 2 \sum_i u(t_i^-) \delta(t - t_i), \quad (14)$$

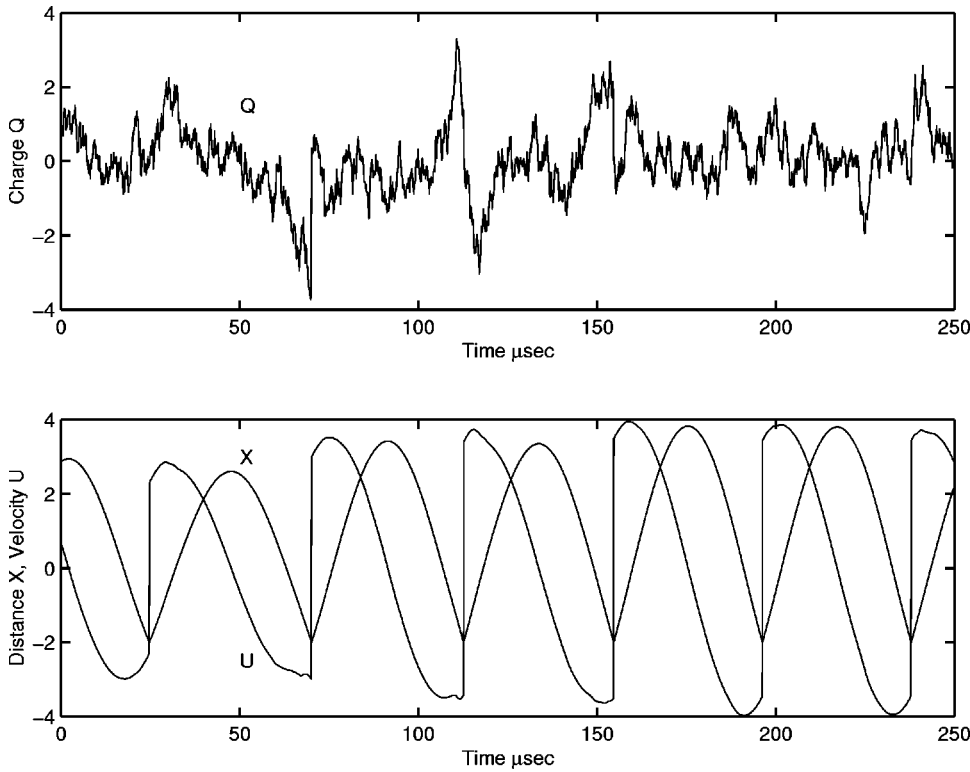

FIG. 4. Simulation results for large perturbations (q set to zero).

where t_i^- is an infinitesimally small time before the time of collision t_i . The extra term accounts for the fact that during an elastic collision, the velocity $u(t) = dx/dt$ reverses in sign so that $u(t_i^+) = -u(t_i^-)$. Taking the time average of this equation over $0 \leq t \leq T$ then yields

$$\langle q^2(t) \rangle = -2\epsilon A \lambda \langle x \rangle - \frac{4\epsilon A m}{T} \sum_i u(t_i^-). \quad (15)$$

Since $-x_0 < \langle x \rangle < 0$ and $u(t_i^-) < 0$, a positive value for $\langle q^2 \rangle$ is obtained. However, whether it remains bounded or not depends on the number of plate collisions in the interval $(0, T)$ in relation to T . From considerations discussed later, it seems that this number may grow faster than T .

Figure 4 shows the results of a simulation after 10 ms in which q was set to zero when the plates collided. In this case, regular collisions between the plates occurred, but not the rapid multiple collisions as seen in Fig. 3.

The following time average means and variances over an interval of 5.0 ms were obtained:

$$\begin{aligned} \langle Q \rangle &= -0.033, & \sigma_Q^2 &= 0.599, \\ \langle X \rangle &= 1.376, & \sigma_X^2 &= 3.421, \\ \langle U \rangle &= 0.006, & \sigma_U^2 &= 8.502. \end{aligned}$$

The results obtained here are clearly different from the previous case. Since the results differ significantly from the theoretical values derived in the Sec. III, it seems that setting $q=0$ at a collision is perhaps not valid. In fact, setting $q=0$ seems to be a Maxwell demon, since the energy in the mechanical system increases without bound.

Figure 5 shows a plot of the mean square value of the velocity U computed over consecutive intervals of length $250 \mu s$ for the simulations of Figs. 3 and 4.

III. DISCUSSION

The Fokker-Planck equation for the time varying joint probability density function $p = p(q, x, u; t)$ is

$$\begin{aligned} \frac{\partial p}{\partial t} + \frac{\partial}{\partial q} \left\{ \frac{-p q (x+x_0)}{\epsilon A R} \right\} + \frac{\partial \{u p\}}{\partial x} \\ + \frac{\partial}{\partial u} \left\{ \left(-\frac{\lambda x}{m} - \frac{q^2}{2\epsilon A m} \right) p \right\} - \frac{kT}{R} \frac{\partial^2 p}{\partial q^2} = 0. \end{aligned} \quad (16)$$

From Eqs. (4), (5) and (6) one can see that the system evolves exactly as a two-dimensional Brownian particle in the (x, q) plane, underdamped in the x direction and overdamped in the q direction, moving under the action of the potential:

$$V(x, q) = \frac{q^2(x+x_0)}{2\epsilon A} + \frac{\lambda x^2}{2}, \quad (17)$$

which is the potential energy of the system.

In normalized form this is

$$V(Q, X) = \frac{1}{kT} V(q, x) = \frac{Q^2(1+X/X_0)}{2} + \frac{X^2}{2}, \quad (18)$$

as shown in Fig. 6 for $X_0 = 2$.

Hence the Gibbs state:

$$p(q, x, u) = \frac{1}{Z} \exp \left[-\frac{1}{kT} \left(\frac{mu^2}{2} + V(x, q) \right) \right], \quad (19)$$

where Z is a normalizing constant, is a particular stationary solution of the Fokker-Planck equation (16).

In normalized form this is

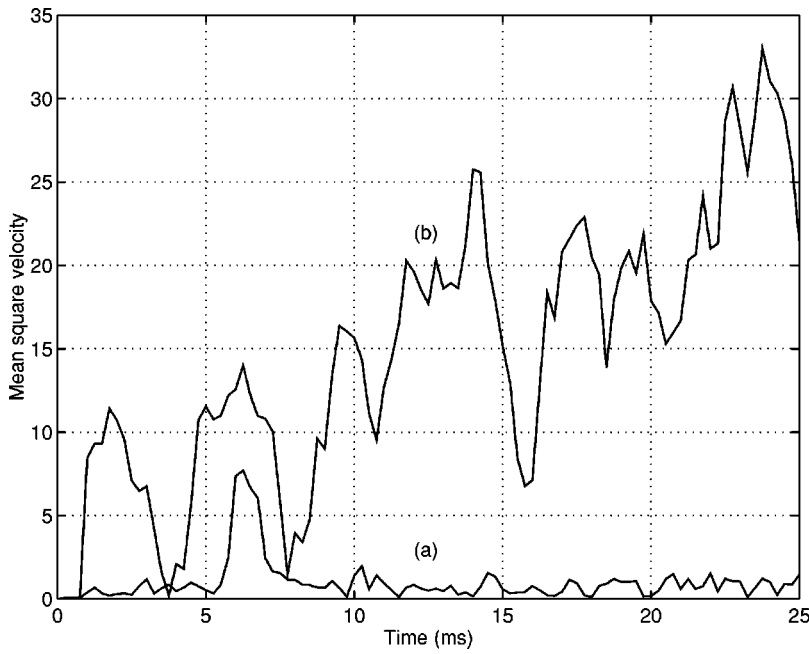

FIG. 5. Mean square velocity (a) q not set to zero, (b) q set to zero.

$$p(Q, X, U) = \frac{1}{Z} \exp \left[-\frac{Q^2(1 + X/X_0)}{2} - \frac{X^2}{2} - \frac{U^2}{2} \right]. \quad (20)$$

However, Eq. (16) is not enough to determine $p(q, x, u)$, and boundary conditions are needed at the point $x = -x_0$. These boundary conditions are the mathematical translation of the prescription used in the simulation for the collisions between the plates of the capacitor.

The elastic collision leaving q unaltered is equivalent to the following boundary condition:

$$p(q, -x_0, u) = p(q, -x_0, -u) \quad (21)$$

for all q and u , whereas the elastic collision setting $q=0$ is equivalent to the singular boundary condition:

$$p(q, -x_0, -u) = \delta(q) \int_{-\infty}^{\infty} p(q', -x_0, u) dq' \quad (22)$$

for all q and $u > 0$.

In the two-dimensional Brownian particle analogy, the first condition is a full elastic collision with the vertical axis $x = -x_0$ whereas the second one consists of taking away any particle colliding with the axis $x = -x_0$ and reinjecting it through the origin $x = -x_0, q = 0$ with the velocity u

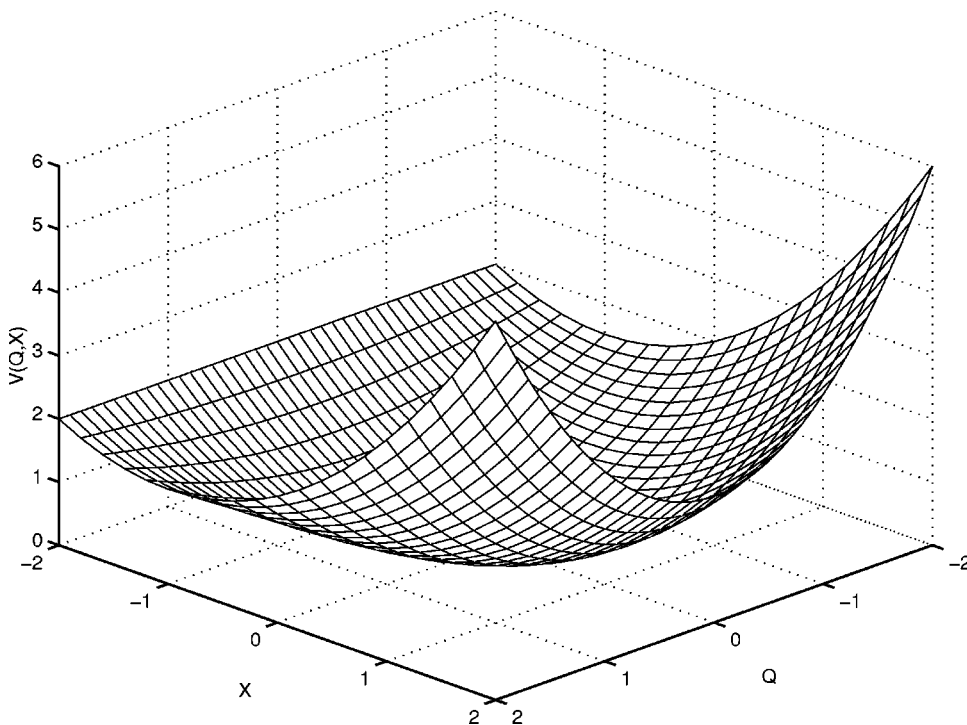

FIG. 6. Potential function.

= dx/dt reversed. We see that the second boundary condition seems natural for the capacitor, but it is very uncommon for a Brownian particle.

It is not hard to see that the probability distribution (19) is compatible with (21) but not (22). Therefore, boundary condition (21) drives the system to thermodynamic equilibrium, as has been seen in the simulations, whereas boundary condition (22) is not compatible with the Gibbs state. Boundary condition (22) can be seen as a source of nonequilibrium since setting $q=0$ does not add energy to the system, but does collapse the probability density function of the system, thus reducing its entropy. It is not surprising then that the boundary condition (22) induces the system to act as a Maxwell demon.

If the perturbations are small (i.e., $x \ll x_0$), the total energy of the system is approximately a quadratic function of the state variables and the average energy associated with each is $\frac{1}{2}kT$. With larger perturbations, the total energy is not a quadratic function of the state variables and hence the average energy associated with each of the degrees of freedom is not $\frac{1}{2}kT$, and this was confirmed by the second simulation.

However Eq. (20) indicates that $\sigma_U^2=1$ and $\sigma_Q^2=\infty$ regardless of the parameters, the latter being a consequence of collisions between the plates. Since in the first simulation no collisions were observed, the system had clearly not reached a steady state, and it would take an extremely long time to do so. The second simulation confirmed that with collisions between the plates, σ_Q^2 becomes larger as expected. The results from the third simulation were not consistent with Eq. (20) so it is concluded that the assumption that $q=0$ at a collision is not correct.

It is interesting to note that as $t \rightarrow \infty$, it is possible for the system to approach a steady state probability density function in which the variance of Q is infinite. While such distributions are somewhat counter-intuitive, they do exist.¹¹ For any finite time, however, the variance of Q must be finite. Because the system is multi-dimensional, a full numerical solution of the Fokker-Planck equation did not seem viable.¹²

From Eq. (20), the probability density functions of Q , X , and U can be determined by integrating over the other state variables. The results are

$$p(Q) = \frac{\sqrt{2\pi}}{Z} \exp\left(-\frac{Q^2}{2} + \frac{Q^4}{8X_0^2}\right) \operatorname{erfc}\left(-X_0 + \frac{Q^2}{2X_0}\right), \tag{23}$$

$$p(X) = \frac{\sqrt{2\pi}}{Z\sqrt{1+X/X_0}} \exp\left(-\frac{X^2}{2}\right), \tag{24}$$

$$p(U) = \frac{1}{\sqrt{2\pi}} \exp\left(-\frac{U^2}{2}\right), \tag{25}$$

where

$$\operatorname{erfc}(z) = \frac{1}{\sqrt{2\pi}} \int_z^\infty \exp\left(-\frac{t^2}{2}\right) dt. \tag{26}$$

It can be shown that $p(Q) = O(Q^{-2})$ as $Q \rightarrow \infty$, confirming the result that the mean square value of Q is unbounded.

A summary of the results obtained for the variable X are shown below. Simulation 1 (Fig. 2) corresponds to $X_0=5$ (for which no collisions occurred), simulation 2 (Fig. 3) corresponds to $X_0=2$ with elastic collisions and leaving q unaltered, and simulation 3 (Fig. 4) corresponds to $X_0=2$ with elastic collisions and setting $q=0$. The theoretical values were obtained by numerical integration of the probability density functions in Eqs. (23)–(25). The theoretical mean values agree well with the approximate analysis presented earlier.

	Simln(1)	Theory(1)	Simln(2)	Simln(3)	Theory(2,3)
$\langle X \rangle$	-0.098	-0.107	-0.284	1.376	-0.296
σ_X^2	0.866	1.039	0.903	3.421	1.141

Our system shares some features with the so-called “adiabatic piston problem.”^{3,4} In both cases the average forces are zero and the system is driven exclusively by fluctuations. If the thermodynamic variables of the piston are the position x of the piston and the temperatures T_1 and T_2 , and the number of particles, N_1 and N_2 , at each side of the piston, then one can readily show that any state with $T_1 N_1/x = T_2 N_2/(L-x)$, L being the total length of the box, is an equilibrium state. These are neither stable nor unstable equilibrium states, but they are “undetermined” or “degenerated,” meaning that the piston can move without any macroscopic force. In the capacitor case, for $\lambda=0$, the potential $V(x,q)$ also has a line of degenerated minima at $q=0$. The difference between the two systems is that in the capacitor problem there are no adiabatic constraints and the system is much simpler as the plate moves toward $x=-x_0$ because the potential $V(x,q)$ has a positive slope in the x direction for any nonvanishing q . Therefore any fluctuation of q , independent of its sign, induces a force pointing to $x=-x_0$.

IV. CONCLUSIONS AND OPEN QUESTIONS

We have proposed an instructive open problem in terms of a demon and a moving plate capacitor. In an effort to understand the modeling of such microelectromechanical systems, we have presented an analysis where the demon is replaced with a simple restoring spring force. In this spring-loaded version, we have pointed out similarities with both the well-known “adiabatic piston problem” in thermodynamics and the engineering application in the modeling of microaccelerometers.

The central open question that remains to be solved is to determine in detail what form the demon does work. Replacing the demon by simple restoring spring has brought up further open questions as follows:

- (1) It seems that setting $q=0$ when the plates collide drives the system out of equilibrium via the boundary conditions, rather than the more usual situation where *explicit* terms added to the equations break the detailed balance. Can a prescription or a new generalized form of the fluctuation dissipation relation be formulated that automatically predicts whether a given boundary condition yields equilibrium or not?

(2) Why does setting $q=0$ result in ever increasing energy in the mechanical system, and where does it come from? Would a satisfactory modeling of how q is set to zero remove the paradox?

(3) When there are collisions between the capacitor plates, the energies associated with the various degrees of freedom do not average to $\frac{1}{2}kT$ even if q is not set to zero. However, even though there is a steady state solution to the Fokker–Planck equation, since $\langle q^2 \rangle$ is unbounded, the energy associated with the capacitor tends to ∞ if the system is run long enough, which seems inconsistent.

(4) It would be interesting to solve the Fokker–Planck equation for the time evolution of the joint probability density function of q , x , and u , and in particular to find how σ_q^2 evolves with time. This would almost certainly have to be a numerical solution.

(5) While it is obvious how the electrical system couples energy into the mechanical system (although this coupling is nonlinear), it is not clear how the electrical system provides damping to the mechanical system so that x and u do not grow without bound.

(6) The model could have included an inductance in series with the capacitor, but this makes the system more complex and would not seem to resolve the paradox in setting q to zero unless the capacitor current is discontinuous or infinite.

(7) The situation where the capacitor plate is of the order of the particle size and subject to collisions with gas molecules is an extension to the problem. The consequences of this are not immediately apparent.

(8) If the temperature and size of the system were such that photon pressure or even virtual photon pressure (Casimir effect) could not be neglected, how would the dynamics change?

(9) Should radiation emission effects be included in the model?

(10) The mechanism by which the demon does work in the original capacitor and resistor system is perhaps related to the observation of the capacitor voltage, but this requires further investigation.

ACKNOWLEDGMENTS

Support from the Australian Research Council, the Sir Ross and Keith Smith Fund (Australia), and the Dirección General de Enseñanza Superior e Investigación Científica (Spain) Project No. PB97-0076-C02 is gratefully acknowledged. Discussions with L. B. Kish (Uppsala University), and N. Fuchikami (Tokyo Metropolitan University) are also acknowledged.

¹L. Szilard, *Z. Phys.* **53**, 840 (1929); English translation in H. S. Leff and A. F. Rex, *Maxwell's Demon: Entropy, Information, Computing* (Hilger, Bristol, 1990).

²P. Penfield, *Proc. IEEE* **54**, 1200 (1966).

³H. B. Callen, *Thermodynamics* (Wiley, New York, 1963).

⁴J. Piasecki and Ch. Gruber, *Physica A* **265**, 463 (1999).

⁵C. T.-C. Nguyen, *IEEE J. Solid-State Circuits* **34**, 440 (1999).

⁶A. Selvakumar and K. Najafi, *J. Microelectromech. Syst.* **7**, 192 (1998).

⁷N. G. van Kampen, *J. Math. Phys.* **4**, 190 (1963).

⁸P. E. Kloeden, E. Platen, and H. Schurz, *The Numerical Solution of Stochastic Differential Equations through Computer Experiments* (Springer, Berlin, 1994).

⁹*Noise in Nonlinear Dynamical Systems*, edited by F. Moss and P. V. E. McClintock (Cambridge University Press, Cambridge, 1989), Vol. 3.

¹⁰D. Abbott, B. R. Davis, N. J. Phillips, and K. Eshraghian, *IEEE Trans. Educ.* **39**, 1 (1996).

¹¹D. T. Gillespie, *Markov Processes* (Academic, New York, 1992), p. 163ff.

¹²V. Palleschi, R. Sarri, G. Marozzi, and M. R. Torquati, *Phys. Lett. A* **146**, 378 (1990).