

Acta Medica Okayama

Volume 48, Issue 1

1994

Article 6

FEBRUARY 1994

An Experimental Hemodynamic Study of the Pelvic Collateral Circulation

Koji Takebe*

Hatsuzo Uchida†

Shigeru Teramoto‡

*Okayama University,

†Okayama University,

‡Okayama Univeristy,

An Experimental Hemodynamic Study of the Pelvic Collateral Circulation*

Koji Takebe, Hatsuzo Uchida, and Shigeru Teramoto

Abstract

Iliac arteries were occluded in adult mongrel dogs to investigate pelvic hemodynamics. When the unilateral common iliac artery was occluded, the blood flow making a "stopover" within the pelvis was found to be significantly less than that of anatomical hemodynamics even under a resting condition. The blood flow decreased more significantly under exercise loading than under a resting condition, which demonstrates the presence of the "steal" phenomenon. This only occurs in the collateral circulation in the pelvis formed by two arterial systems which are related in a series. In deciding the appropriacy of reconstruction for the internal iliac artery in patients with aorto-iliac occlusive disease, this "steal" phenomenon should be kept in mind. In most cases, ischemic symptoms in pelvic organs may be due to a simple decrease of the blood flow supplied to the pelvis, or due to the "steal" phenomenon. If the pelvic region is in the state of ischemia owing to the "steal" phenomenon, reconstruction of the blood vessels flowing into the pelvis is not required.

KEYWORDS: aortoiliac disease, aortoiliac reconstruction, pelvic hemodynamics, vascular steal syndrome

*PMID: 8191914 [PubMed - indexed for MEDLINE]

Copyright (C) OKAYAMA UNIVERSITY MEDICAL SCHOOL

An Experimental Hemodynamic Study of the Pelvic Collateral Circulation

KOJI TAKEBE*, HATSUZO UCHIDA AND SHIGERU TERAMOTO

Second Department of Surgery, Okayama University Medical School, Okayama 700, Japan

Iliac arteries were occluded in adult mongrel dogs to investigate pelvic hemodynamics. When the unilateral common iliac artery was occluded, the blood flow making a "stopover" within the pelvis was found to be significantly less than that of anatomical hemodynamics even under a resting condition. The blood flow decreased more significantly under exercise loading than under a resting condition, which demonstrates the presence of the "steal" phenomenon. This only occurs in the collateral circulation in the pelvis formed by two arterial systems which are related in a series. In deciding the appropriateness of reconstruction for the internal iliac artery in patients with aorto-iliac occlusive disease, this "steal" phenomenon should be kept in mind. In most cases, ischemic symptoms in pelvic organs may be due to a simple decrease of the blood flow supplied to the pelvis, or due to the "steal" phenomenon. If the pelvic region is in the state of ischemia owing to the "steal" phenomenon, reconstruction of the blood vessels flowing into the pelvis is not required.

Key words: aortoiliac disease, aortoiliac reconstruction, pelvic hemodynamics, vascular steal syndrome

Leriche and Morel (1) first described ischemic symptoms of pelvic organs including impotence and gluteal claudication accompanying occlusive disease in the aorto-iliac region. More recently, as incidence of occlusive arterial sclerosis has been increasing among younger people, the correction of impotence has become a greater problem for the better quality of life. Attention should be paid to improvement of the blood flow not only to the legs, but also to the region of organs within the pelvis when reconstruction of blood circulation is made in the aorto-iliac region. Actually, clinical reconstruction of

the internal iliac artery has become more frequent (2, 3).

In the selection of any operative treatment for patients with occlusive disease in the aorto-iliac region, especially for reconstruction of the internal iliac artery, a decision should be made only after objective evaluation has been made on hemodynamics of the collateral circulation within the pelvis. In the clinical setting, hemodynamics within the pelvis is evaluated in various ways; in most cases, clinical symptoms and angiographic findings are the major determining factors. Evaluation based on quantitative factors has been restricted to the aspect of blood pressure. We have not found any published evaluation from the aspect of blood flows in such patients.

We prepared various occlusion models in the iliac region of adult mongrel dogs to measure the blood flow of the internal iliac artery on both sides and the local blood flow of the rectum. By doing so, we tried to define pelvic hemodynamics at the time of occlusion of the iliac artery. We also investigated whether the so-called pelvic "steal" phenomenon might be induced by forming a shunt between the left deep femoral artery and the internal jugular vein. We prepared a femoro-femoral bypass to better define the pathology of the "steal" phenomenon at the time of reconstruction of blood circulation in the leg.

Materials and Methods

Experimental animals and anesthetic procedures. We used 21 adult mongrel dogs that weighed from 9 to 26 kg. Dogs were anesthetized by an intramuscular injection of ketamine hydrochloride 5 mg/kg and an intravenous injection of thiopental sodium 10 mg/kg. After an intratracheal tube was intubated, anesthesia was maintained during surgery using 50% nitrous oxide mixed with oxygen. Respiration was controlled by a volume cycle respirator (Harvard Ventilator Model 613, USA) with a tidal volume of 15 ml/kg. Pancronium

* To whom correspondence should be addressed.

bromide was administered as a muscle relaxant in the initial dose of 2 mg, which was followed by doses of 0.4 mg as occasion demanded.

Preparation of hemodynamic models.

The internal iliac artery directly branches off from the aorta in dogs. Therefore, the left common iliac artery was prepared by end-to-side anastomosis between the left internal iliac artery and the left external iliac artery. A simplified model for pelvic hemodynamics was prepared by ligating the inferior mesenteric artery, the lower lumbar arteries, and the deep femoral artery. The internal iliac artery remained as the major blood vessel to serve the pelvic organs. Then, an external shunt was prepared between the left deep femoral artery and the left internal jugular vein (Fig. 1 left).

When hemodynamics was stabilized after anastomosis and preparation of the shunt, blood flow was blocked with small forceps, and the following six different types of hemodynamic models were prepared.

Model I. Anatomical hemodynamic model without

occlusion of the iliac artery.

Model II. Occlusion of the left common iliac artery.

Model II-bypass. Femoro-femoral bypass was added to the model II.

Model IIIr. Occlusion of the right internal iliac artery.

Model IIIl. Occlusion of the left internal iliac artery.

Model IV. Occlusion of the bilateral internal iliac arteries.

The unbranched cervical common carotid artery, which is approximately the same size as the iliac artery, was resected and used as a free autogenous graft between the two femoral arteries in II-bypass models.

In model II, it was assumed that blood supply to the leg was maintained through collateral circulation within the pelvis.

Experimental Designs

Experiment 1. The blood supplying capacity of the pelvic collateral circulation of model II was evaluated in terms of blood flow and blood pressure (Fig. 1). Femoral blood flows on both sides were measured under

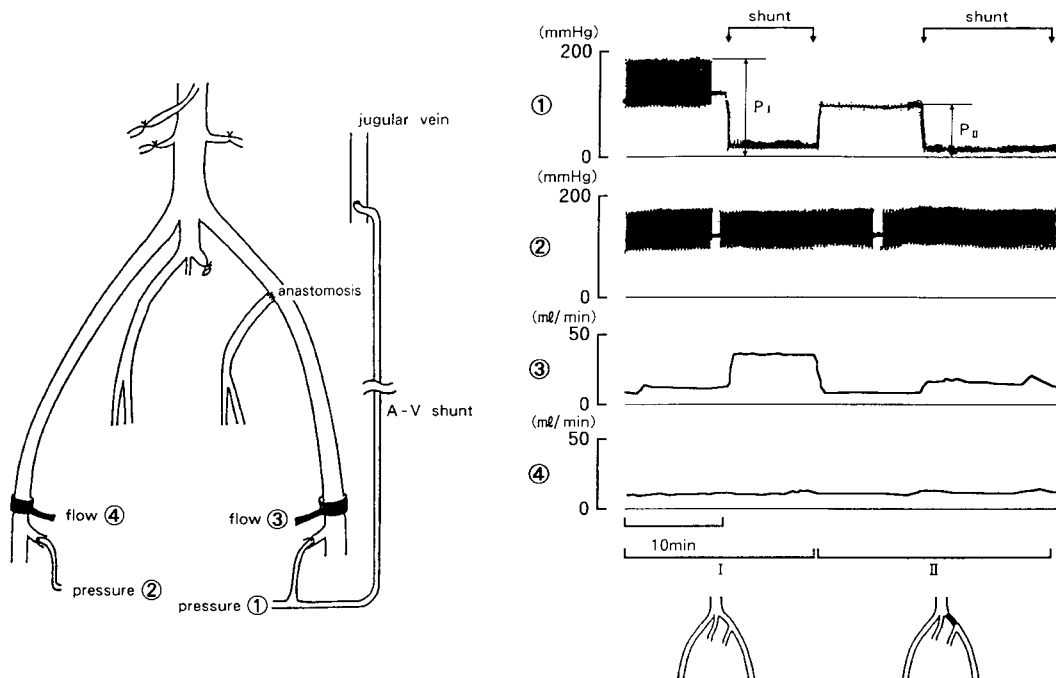

Fig. 1 A diagram and a representative measurement in experiment I. ①: The pressure of the left femoral artery. It was measured through the cannulae in the shunt, so the pressure could not be monitored when the shunt was opened. The pressure index was represented as resting systolic pressure of the femoral artery in model II/resting systolic pressure of the femoral artery in model I. ③: The blood flow of the left femoral artery. The blood flow definitely increased after the shunt was opened. In model II, there was also an increase, but the increase was not so great as the one observed in model I. ②④: The pressure and the blood flow of the right femoral artery. Neither varied in any model of hemodynamics.

two different conditions (with a shunt open or closed) in models I and II using 13 dogs. A Doppler flow meter (Transonic Systems Inc. USA T201 2 channel Ultrasonic Blood Flow Meter) was used for the measurement after hemodynamics was fully stabilized. The average blood flow was evaluated by integrating blood flow curves recorded for more than 5 min. Blood pressure in both femoral arteries was continuously recorded on a polygraph (San-ei Co., Tokyo Japan) by pressure transducers.

Experiment 2. Hemodynamics of pelvic collateral circulation was evaluated in terms of the local blood flow in pelvic organs. The local blood flow of the rectum was measured in the five versions of hemodynamic models (I to IV except II-bypass) prepared in eight other dogs. The blood flow was measured by a laser local blood flow meter (Advance Inc. USA AFL2100 Laser Flow Meter) at the serous surface on the opposite side of the mesenteric attachment of the rectum (Fig. 2). The shunt was kept open during experiments. The average local blood flow was measured in the same way as in experiment 1.

Experiment 3. Hemodynamics of pelvic collat-

eral circulation was evaluated in terms of blood flows of the bilateral internal iliac arteries serving as the inflow and outflow arteries, respectively, for the collateral circulation (Fig. 3). Blood flows of the bilateral internal iliac arteries were measured in the same way as in experiment 1 under both conditions (with a shunt open or closed) for each of the three different models (I, II, and II-bypass) in the 13 dogs used in experiment 1.

Significance of the difference between values was examined by the paired Student's *t* test. Values are expressed as the mean \pm SD.

All animals received human care in compliance with the "Advisory Notes on the Maintenance of Anesthetized Animals when Muscle Relaxants are Used" produced by the Physiological Society and with the "Principles of Laboratory Animal Care" formulated by the National Society of Medical Research and the "Guide for the Care and Use of Laboratory Animals" prepared by the National Academy of Sciences and published by National Institute of Health (NIH Publication. No. 80-23, revised in 1978).

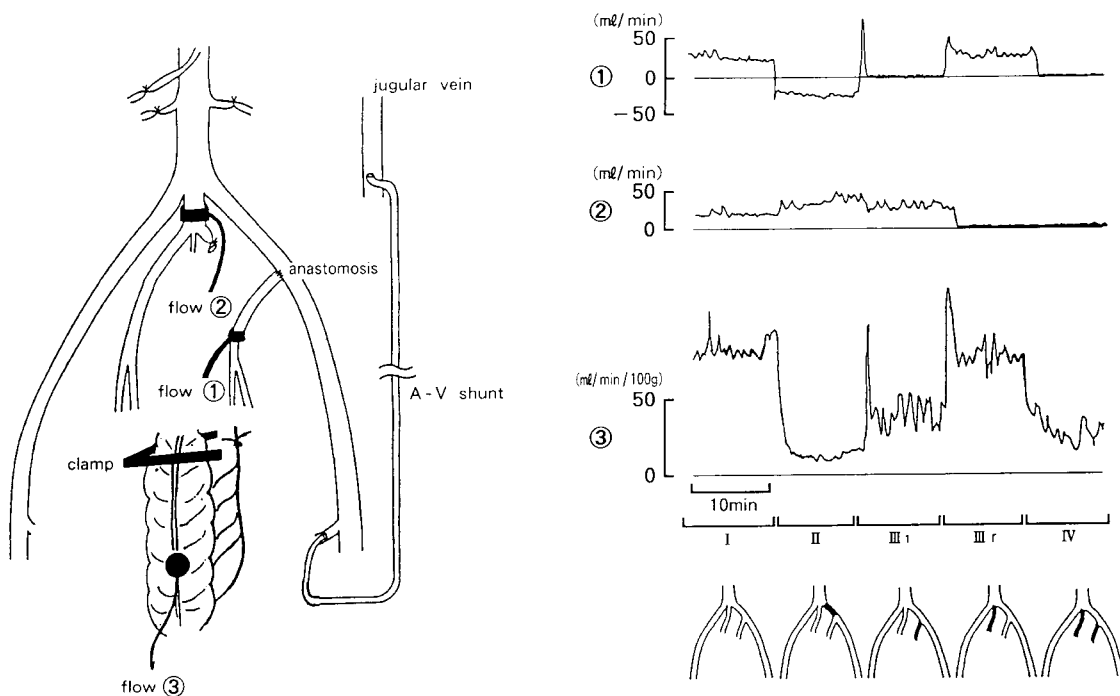

Fig. 2 A diagram and a representative measurement in experiment 2. The shunt was kept open during the experiment. ①: The blood flow of the left internal iliac artery. ②: The blood flow of the right internal iliac artery. In this experimental model, the left internal iliac artery predominated in the blood supply to the rectum. ③: The local blood flow of the rectum. The local blood flow in models II and IV decreased more than the flow in models, I, IIIr, and III. The blood flow curve in model II was more constant than in model IV.

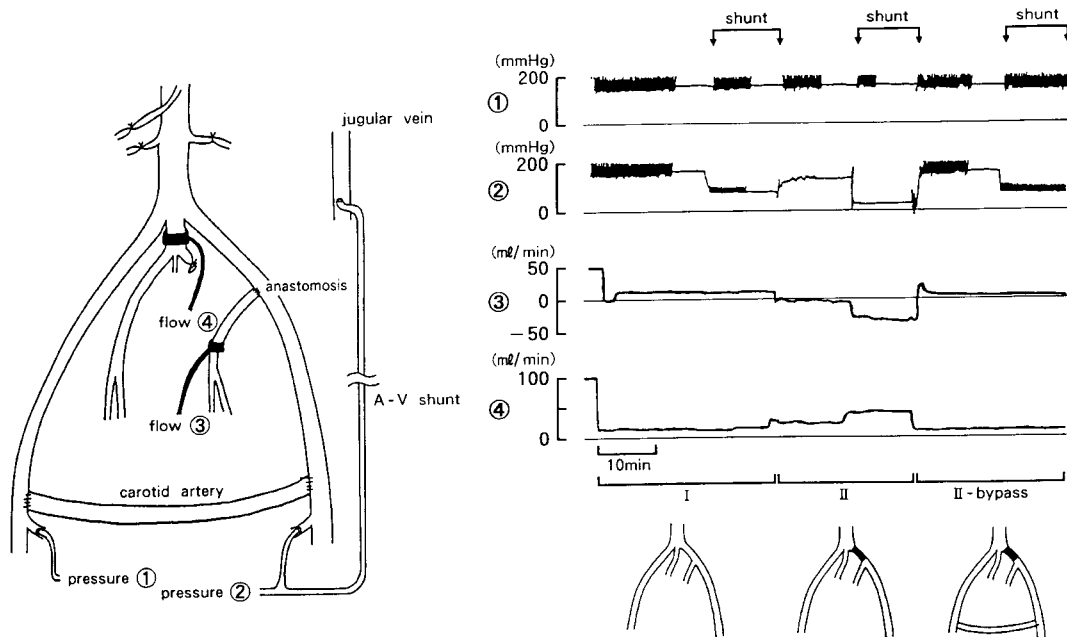

Fig. 3 A diagram and a representative measurement in experiment 3. ①: The pressure of the right femoral artery. ②: The pressure of the left femoral artery. ③: The blood flow of the left internal iliac artery. ④: The blood flow of the right internal iliac artery. In models I and II-bypass, the blood flows of the left and right internal iliac arteries were found constant whether the shunt was opened or closed. In model II, the blood flow of the left internal iliac artery flowed backward and decreased when the shunt was opened. Compared to model I (anatomical hemodynamics), the blood flow of the right internal iliac artery increased and it increased further when the shunt was opened.

Results

Experiment 1. Fig. 1 shows a representative measurement of this experiment. Fig. 4 shows the blood flow of the left and right femoral arteries in the 13 dogs.

In models I and II, the blood flow volumes of the left femoral arteries increased from 23 ± 11 ml/min to 102 ± 25 ml/min, and from 11 ± 7 ml/min to 29 ± 16 ml/min, respectively, when the shunt was open. Whereas those of right femoral artery did not change in either I or II model irrespective of the shunt open or closed, showing the

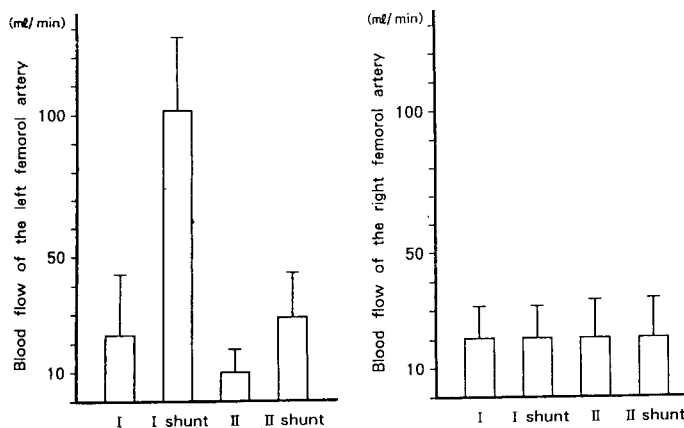

Fig. 4 The blood flow of the left and right femoral arteries in the 13 dogs. The blood flow of the right femoral artery remained constant in both models I and II, irrespective of the shunt open or closed, while the blood flow of the left femoral artery increased by 4.4 times when the shunt was opened in model I, and 2.6 times in model II.

values from 21 ± 11 ml/min to 21 ± 11 ml/min, and from 21 ± 13 ml/min to 21 ± 11 ml/min, respectively, when the shunt was open.

We provided the pressure index (Fig. 1) using the following calculation to determine the blood supplying capacity of the pelvic collateral circulation.

Pressure index = resting systolic pressure of the femoral artery in model II/resting systolic pressure of the femoral artery in model I.

The mean of the pressure index in the 13 dogs was 0.50 ± 0.10 .

Experiment 2. Fig. 2 shows a representative measurement of this experiment. Fig. 5 shows the results of the eight dogs. In models I, II, IIIr, IIIl, and IV, the local blood flow volumes on the serous surface of the rectum were 26 ± 10 ml/min/100 g, 12 ± 7 ml/min/100 g, 21 ± 9 ml/min/100 g, 22 ± 5 ml/min/100 g, and 11 ± 4 ml/min/100 g, respectively. When compared between models II and III, the local blood flow of the rectum was significantly less in the model II than in the model III, although in both models, the blood was supplied to the pelvis via only one vessel. This experimental model may simulate the case in which the same angiographic findings would be observed in the blood vessels flowing into the pelvic region.

The blood flow of the rectum was not significantly different between models II and IV, although model IV

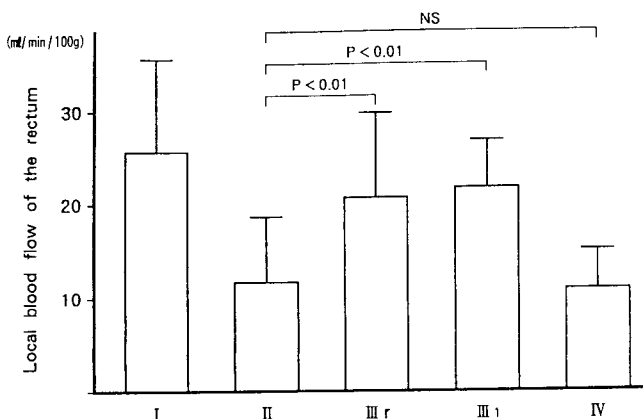

Fig. 5 The local blood flow of the rectum in the eight dogs. The shunt was kept open during experiment. Comparison between models II and III demonstrated that the blood flow of the rectum was significantly less in model II ($P < 0.01$). Model II proved to have no significant difference from model IV.

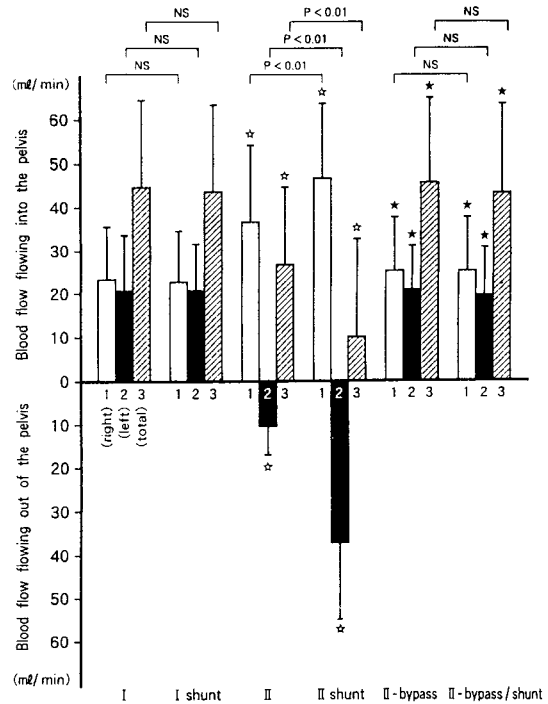

Fig. 6 Blood flows flowing into and out of the pelvis in the 13 dogs. 1: The blood flow of the right internal iliac artery. 2: The blood flow of the left internal iliac artery. 3: The total pelvic blood flow. In model II under both conditions (with a shunt open or closed), all blood flows were significantly different from those in model I (anatomical hemodynamics) ($\star P < 0.01$), while in model II-bypass under both conditions, all blood flows were not significantly different from those of model I. (\star NS). Comparison of blood flow between two conditions (with a shunt open or closed) demonstrated no significant differences in I and II-bypass models. But between two conditions in model II, the blood flow of the right internal iliac artery showed significant increase, while the blood flow of the left internal iliac artery and the total pelvic blood flow showed significant decrease ($P < 0.01$).

had no major blood vessel for supplying the blood to the pelvis.

Experiment 3. Fig. 3 shows a representative measurement of this experiment. Fig. 6 shows blood flows of the bilateral internal iliac arteries and the total pelvic blood flow into or out of the pelvis through the bilateral internal iliac arteries in the 13 dogs. The blood flow volumes of the right internal iliac artery changed from 24 ± 12 ml/min to 23 ± 12 ml/min in model I, from 37 ± 17 ml/min to 47 ± 17 ml/min in model II, and from

25 ± 13 ml/min to 25 ± 13 ml/min in model II-bypass, respectively, when the shunt was open. Whereas those of the left internal iliac artery showed from 21 ± 13 ml/min to 21 ± 11 ml/min in model I, from -10 ± 7 ml/min to -37 ± 18 ml/min in model II, and from 21 ± 10 ml/min to 19 ± 12 ml/min in model II-bypass, respectively, when the shunt was open.

The reason why the blood flow in model II significantly decreased was because the blood from the pelvis flowed backward in the left internal iliac artery, which was recorded as a negative blood flow.

Regarding the total pelvic blood flow, the flow volumes at the time from closed to open shunt were 45 ± 20 ml/min and 44 ± 20 ml/min in model I, 27 ± 18 ml/min and 10 ± 23 ml/min in model II, and 46 ± 20 ml/min and 44 ± 20 ml/min in model II-bypass, respectively.

The blood flows of the bilateral internal iliac arteries and the total pelvic blood flow under both conditions (with a shunt open or closed) in model II was significantly different from those of model I (anatomical hemodynamics) (Fig. 6). When the shunt was closed (under a resting condition), the total pelvic blood flow in model II decreased significantly because the decrease in the blood flow of the left internal iliac artery is larger than the increase in the blood flow of the right internal iliac artery. The blood flow decreased more when the shunt was open (under exercise loading). The model II-bypass with a shunt open or closed showed no significant differences from model I (anatomical hemodynamics) in the blood flow pattern.

Comparison of blood flows between two conditions (with a shunt open or closed) demonstrated no significant differences in either model I or II-bypass.

Discussion

"Steal" phenomenon. DeBakey *et al.* (4) noted that when two different arterial systems receive blood from the same blood vessel in the human body, one preferentially receives blood at the expense of the other. They called it the borrowing lending phenomenon, and emphasized that it should be taken into account in treating pathological lesions of the peripheral vessel. Subsequently Hyman and Winsor (5) called the phenomenon the diversion phenomenon. Contorni (6) and Reivich *et al.* (7) described a pathological condition characterized by a reduction of cerebral blood flow under exercise loading of the upper limbs at the time of stenosis or occlusion of the

subclavian artery under the name of subclavian steal syndrome. Today these phenomena are collectively defined as the vascular "steal" phenomenon.

There are several ways to increase the blood flow by reducing the peripheral vascular resistance in the limbs and to establish hemodynamics under exercise loading. Ehrenfeld *et al.* (8) investigated hemodynamics in the "steal" phenomenon using a peripheral arterio-venous fistula, which is a simple method to increase the blood flow.

We used an external shunt in this study, because it was a simple method that ensured a greater variation of the blood flow. The hemodynamic models used in this study proved to have little effect on the somatic circulation and were thus considered to be closer to hemodynamics under exercise loading.

Numerous studies have been made on the vascular "steal" phenomenon that occurs in subclavian steal syndrome, as well as in ischemic symptoms of the donor limb after the femoro-femoral bypass, and in ischemic symptoms of the colon after vascular reconstruction in the leg (8-10). Ehrenfeld *et al.* (8) tried to experimentally demonstrate the "steal" phenomenon that occurs after vascular reconstruction in two different arterial systems of the dog's legs. They did not see development of any "steal" phenomenon, and stated that the ischemic symptoms of the colon following arterial reconstruction in the leg could not be explained by the "steal" phenomenon. Landymore *et al.* (9) made experiments on the "steal" phenomenon that occurred after the femoro-femoral bypass using the dog's bilateral legs. They concluded that no "steal" phenomenon was seen in the donor limb even when the blood flow increased by more than 10 times in the recipient limb. Both groups of authors observed two arterial systems that were in a parallel relation to the aorta.

In our experiment 1, the right and left femoral arteries were in a parallel relation to the aorta. The blood flow of the right femoral artery remained constant in model I irrespective of a resting condition and exercise loading although the blood flow of the left femoral artery increased by 4.4 times under exercise loading. In experiment 3, the left and right internal iliac arteries and the left femoral artery were in a parallel relation to the aorta in models I and II-bypass. In these hemodynamic models, the blood flow of the internal iliac artery on both sides remained constant irrespective of a resting condition and exercise loading. These results support the statement that the "steal" phenomenon may not occur in arterial systems in

a parallel relationship to the aorta.

Billet *et al.* (10) made experiments on the "steal" phenomenon of two arterial systems in a parallel relation by measuring the blood supplying capacity of the aorta (parent artery). They found that the "steal" phenomenon occurred only when the parent artery was in 60% stenosis. They stated that all of "steal" phenomena could be explained by this condition. However, their experiments only referred to the "steal" phenomenon of arterial systems in a parallel relation. And the conclusion that all "steal" phenomena can be so explained is doubtful.

The blood flow to the upper limbs in the subclavian steal syndrome is supplied through collateral circulation in which the carotid artery serves as an inflow artery and the vertebral artery as an outflow artery. The cerebral arterial system and the arterial system of the upper limb may be said to be in a series relation. In model II, the same type of hemodynamics was set up within the pelvis.

The following conclusions were based on the results of experiments 2 and 3. When the pelvic circulation changed to the collateral pathway that supplied the blood to the arterial system of the leg, the blood flow making a "stopover" within the pelvic collateral circulation was significantly lower than in model I (anatomical hemodynamics) even under a resting condition. The blood flow decreased more significantly under exercise loading than under a resting condition. This finding indicates the possible occurrence of the "steal" phenomenon in the organs of the pelvis. We suggest that the phenomenon may be eliminated by vascular reconstruction of the leg without additional operations for the pelvic collateral circulation.

We have concluded that the "steal" phenomenon observable in the clinical setting occurs in the collateral circulation formed by two arterial systems in a series relation. If the arterial systems are in a parallel relation, the "steal" phenomenon may only be seen under special conditions.

Pelvic hemodynamics. In the iliac occlusion model (model II) the blood was supplied via the bilateral internal iliac arteries which served as inflow and outflow arteries to the leg through the vascular bed of the organs within the pelvis. It was designed to simulate a typical type of occlusion in the aorto-iliac region that has the pelvic vascular bed within the collateral circulation. Despite acute experiments, a sufficient blood supplying capacity was obtained; segmental pressure ratio of 0.50 (experiment 1). Model II represented a severe iliac occlusion that might be classified as degree II or III in

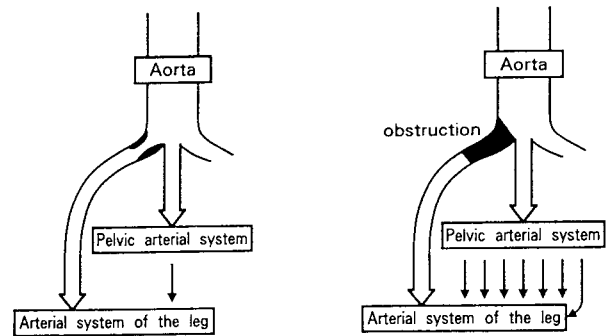

Fig. 7 The relation between the pelvic arterial system and the arterial system of the leg. Left: Parallel relation-predominant type, Right: Series relation-predominant type.

Fontaine's classification (11).

The relation between the pelvic arterial system and the arterial system of a leg with occlusion in the aorto-iliac region may be classified into either the series relation-predominant type or parallel relation-predominant type (Fig. 7). One may easily imagine a series relation through a variety of collateral circulations in the case of complete occlusion. Boender *et al.* (12), Friedenberg *et al.* (13), and Hassen-Khodja *et al.* (14) used angiography to investigate and classify pelvic collateral circulation in a series relation to the arterial system of the leg. They found that visceral branches of the internal iliac artery, especially a path of circulation through the rectum played the most important role as a collateral circulation to the leg.

Aortic branches in patients with aorto-iliac occlusive disease often become narrow or obstructed, but sometimes become enlarged. In this study, all aortic branches except iliac arteries were ligated. If the inferior mesenteric artery was not ligated, local blood flow of the rectum was not stolen in experiment 2. The common iliac arteries and many other vessels in dogs can serve as collateral circulation that supplies the blood from the pelvis to the leg. Therefore, we prepared a simplified model by ligating the aortic branches and found that visceral branches of the internal iliac artery in the pelvis played the most important role as a collateral circulation to the leg in model II.

Hemodynamics in the pelvic arterial system may be quantitatively assayed by three methods; the penile pressure index (2, 3), the penile volume recording (15), and blood flow patterns by the intrarectal Doppler method

(16). A majority of authors have found such methods to be useful, but some authors (17) cast doubt on the validity of the penile pressure index. In these methods too, the priority is given to evaluation of the blood supplying capacity to the pelvic arterial system from the aorta without due consideration of the relation to the arterial system of the leg. Goldstein *et al.* (18), however, measured the penile pressure index under exercise loading of the leg. They tried to correctly define the condition of vasculogenic impotence and compared it to the one under resting condition using the pelvic steal test. They tried to explain the pelvic steal phenomenon by assuming that the leg and pelvic arterial systems were in a parallel relation. That was the same concept advocated by Billet *et al.* (10) and contradictory to the one proposed by us.

Our experiments were the first to demonstrate experimentally the "steal" phenomenon in the pelvic arterial system in a series relation to the arterial system of the leg. The same phenomenon has been reported by Labs *et al.* (19) under the name of superior gluteal artery steal syndrome and by Michal *et al.* (20) under the name of external iliac steal syndrome. That is, it may be said that the "steal" phenomenon demonstrated in this study is not a paper theory that can be observed only by experiments.

When traditional angiograms and blood flow scintigrams are read, it is most important to define the relation between the arterial systems in the pelvis and legs by paying full attention to their changes due to several phases (*i.e.*, phases of the aorta, iliac artery, capillary vessels within the pelvis, and the femoral artery).

If the pelvic region is in the state of ischemia due to the "steal" phenomenon, caution should be exercised in deciding the appropriacy of reconstruction for the internal iliac artery. If the pelvic circulatory system serves as a collateral circulation to the leg receiving poor blood supply, it is very likely that pelvic organs may be in the state of ischemia due to the "steal" phenomenon. In such hemodynamics, ischemia of the pelvic organs does not require reconstruction of the blood vessels flowing into the pelvis as shown in experiment 3. It may be improved simply by reconstruction of the blood circulation to the leg by changing the arterial systems of the leg and the pelvis into parallel relation.

References

- Leriche R and Morel A: The syndrome of thrombotic obliteration of the aortic bifurcation. *Ann Surg* (1948) **127**, 193-206.
- Queral LA, Whitehouse WM, Flinn WR, Zarins CK, Bergan JJ and Yao JST: Pelvic hemodynamics after aorto-iliac reconstruction. *Surgery* (1979) **86**, 799-809.
- Flanigan DP, Sobinsky KR, Schuler JJ, Buchbinder D, Borozan PG and Meyer JP: Internal iliac artery revascularization in the treatment of vasculogenic impotence. *Arch Surg* (1985) **120**, 271-274.
- DeBaakey ME, Burch G, Ray T and Ochsner A: The "borrowing lending" hemodynamic phenomenon (hemometakinesia) and its therapeutic application in peripheral vascular disturbances. *Ann Surg* (1947) **126**, 850-864.
- Hyman C and Winsor T: Blood flow redistribution in the human extremity: The diversion phenomenon. *Am J Cardiol* (1959) **4**, 566-571.
- Contorni L: Il circolo collaterale vertebro-vertebrale nella oblitterazione dell'arteria succlavia alla sua origine. *Minerva Chir* (1960) **51**, 268-272.
- Reivich M, Holling HE, Roberts B and Toole JF: Reversal of blood flow through the vertebral artery and its effect on cerebral circulation. *N Engl J Med* (1961) **265**, 878-885.
- Ehrenfeld WK, Harris JD and Wylie EJ: Vascular "steal" phenomenon: An experimental study. *Am J Surg* (1968) **116**, 192-197.
- Landymore RW, Kinley CE and Marble AE: Does vascular steal occur following femorofemoral bypass grafting? *Can J Surg* (1980) **23**, 563-565.
- Billet A, Queral LA, Polito WF and Dagher FJ: The vascular steal phenomenon: An experimental model. *Surgery* (1984) **96**, 923-928.
- Fontaine R, Kim M and Kiency R: Die chirurgische Behandlung der peripheren Durchblutungsstörungen. *Helv Chir Acta* (1954) **21**, 499-533.
- Boender AC and Perlberger RR: An attempt to classify the collateral systems in total occlusions at different levels of the lumbar aorta and pelvic arteries: Causes and consequences. *Radiol Clin* (1977) **46**, 345-363.
- Friedenberg MJ and Perez CA: Collateral circulation in aorto-ilio-femoral occlusive disease. *Am J Roentg* (1965) **94**, 145-158.
- Hassen-Khodja R, Batt M, Michetti C and Bas PL: Radiologic anatomy of the anastomotic systems of the internal iliac artery. *Surg Radiol Anat* (1987) **9**, 135-140.
- Merchant RF and DePalma RG: Effects of femorofemoral grafts on postoperative sexual function: Correlation with penile pulse volume recordings. *Surgery* (1981) **90**, 962-970.
- Iwai T, Sato S, Muraoka Y, Sakurazawa K, Kinoshita H, Inoue Y, Endo M and Yoshida T: The assessment of pelvic circulation after internal iliac arterial reconstruction: A retrospective study of the treatment for vasculogenic impotence and hip claudication. *Jpn J Surg* (1989) **19**, 549-555.
- Gaylis H: Penile pressure in the evaluation of impotence in aortoiliac disease. *Surgery* (1981) **88**, 277-278.
- Goldstein I, Siroky MB, Nath RL, McMillian TN, Menzoian JO and Krane RJ: Vasculogenic impotence: Role of the pelvic steal test. *J Urol* (1982) **128**, 300-306.
- Labs JD, Williams GM, Manson PN and Hoopes JE: Case report: Superior gluteal artery steal syndrome. *Br J Plast Surg* (1989) **42**, 603-606.
- Michal V, Kramar R, Pospichal J: External iliac "steal syndrome". *J Cardiovasc Surg* (1978) **19**, 355-357.

Received March 23, 1993; accepted August 9, 1993.

1. Leriche R and Morel A: The syndrome of thrombotic obliteration of the