

Acta Medica Okayama

Volume 40, Issue 5

1986

Article 3

OCTOBER 1996

Artificial liver support for postoperative hepatic failure with anion exchange resin (BR-601).

Kenichi Sakagami*

Masashi Miyazaki[†]

Junji Matsuoka[‡]

Shigehiro Shiozaki**

Shinya Saito^{††}

Kunzo Orita^{‡‡}

*Okayama University,

[†]Okayama University,

[‡]Okayama University,

**Okayama University,

^{††}Okayama University,

^{‡‡}Okayama University,

Artificial liver support for postoperative hepatic failure with anion exchange resin (BR-601).*

Kenichi Sakagami, Masashi Miyazaki, Junji Matsuoka, Shigehiro Shiozaki, Shinya Saito, and Kunzo Orita

Abstract

An artificial liver support system for plasma exchange and plasma perfusion through BR-601 resin using a membrane separator was applied to 5 patients with postoperative liver failure. Percent absorption of total and direct bilirubin, and of bile acids were 77.1 +/- 6.4, 78.4 +/- 6.1, and 93.4 +/- 3.6%, respectively, when 250 ml of plasma was treated. Percent reductions in total and direct bilirubin, and in bile acids were 24.5 +/- 5.8, 25.5 +/- 5.8 and 30.9 +/- 8.5%, respectively. In contrast, percent reductions in total and direct bilirubin, and in bile acids by plasma exchange were 30.9 +/- 13.3, 34.5 +/- 12.5 and 24.2 +/- 8.5%, respectively. The coma grade was improved in 4 out of 5 cases, but unfortunately the patients did not recover. In conclusion, plasma perfusion through BR-601 resin is expected to play a promising role in artificial liver support systems because of its capacity to absorb bilirubin and bile acids.

KEYWORDS: anion exchange resin (BR-601), postoperative liver failure, artificial liver support

*PMID: 3788665 [PubMed - indexed for MEDLINE]

Copyright (C) OKAYAMA UNIVERSITY MEDICAL SCHOOL

Artificial Liver Support for Postoperative Hepatic Failure with Anion Exchange Resin (BR-601)

Kenichi Sakagami, Masashi Miyazaki, Junji Matsuoka, Shigehiro Shiozaki, Shinya Saito, and Kunzo Orita

First Department of Surgery, Okayama University Medical School, Okayama 700, Japan

An artificial liver support system for plasma exchange and plasma perfusion through BR-601 resin using a membrane separator was applied to 5 patients with postoperative liver failure. Percent absorption of total and direct bilirubin, and of bile acids were 77.1 ± 6.4 , 78.4 ± 6.1 , and $93.4 \pm 3.6\%$, respectively, when 250 ml of plasma was treated. Percent reductions in total and direct bilirubin, and in bile acids were 24.5 ± 5.8 , 25.5 ± 5.8 and $30.9 \pm 8.5\%$, respectively. In contrast, percent reductions in total and direct bilirubin, and in bile acids by plasma exchange were 30.9 ± 13.3 , 34.5 ± 12.5 and $24.2 \pm 8.5\%$, respectively. The coma grade was improved in 4 out of 5 cases, but unfortunately the patients did not recover. In conclusion, plasma perfusion through BR-601 resin is expected to play a promising role in artificial liver support systems because of its capacity to absorb bilirubin and bile acids.

Key words : anion exchange resin (BR-601), postoperative liver failure, artificial liver support

In recent years, the opportunity of performing extended operations for malignant tumors of the liver, gallbladder and pancreas has increased. As a consequence of such operations, postoperative hepatic failure has occurred with increasing frequency. While glucagon-insulin therapy (1), administration of amino acid preparations for liver failure (2) as well as plasma exchange (PE) therapy (3, 4) are actively employed for postoperative hepatic failure, the survival rates following such treatments remain low. BR-601 (5), an anion exchange resin, is known to possess high affinities for protein-bound substances, such as bilirubin, which increase in the blood during hepatic failure. In the present preliminary study, plasma perfusion (PP) with BR-601 set in the plasma separator was applied clinically as an artificial

liver support system to patients with serious postoperative hepatic failure, and its effectiveness was evaluated.

Materials and Methods

Subjects. As shown in Table 1, from July to December, 1985, 21 sessions of PE therapy and 28 sessions of PP therapy using BR-601 resin were performed as 5 patients with postoperative hepatic failure. In cases 1-4, total bilirubin values were reduced below 2 mg/dl with percutaneous transhepatic catheter drainage prior to the operation. Except in case 5, the outbreak of postoperative hepatic failure occurred 9.7 ± 6.9 days after the operation, with a coma grade of III-IV and total bilirubin value of 14.7 ± 5.7 mg/dl.

Adsorbent. BR-601 (Asahi Medical Co., Japan) is a strongly basic anion exchange resin consisting of styrene divinylbenzene copolymer as a base with

Fig. 1 Scanning electron micrograph of the BR-601 resin beads. $\times 200$.

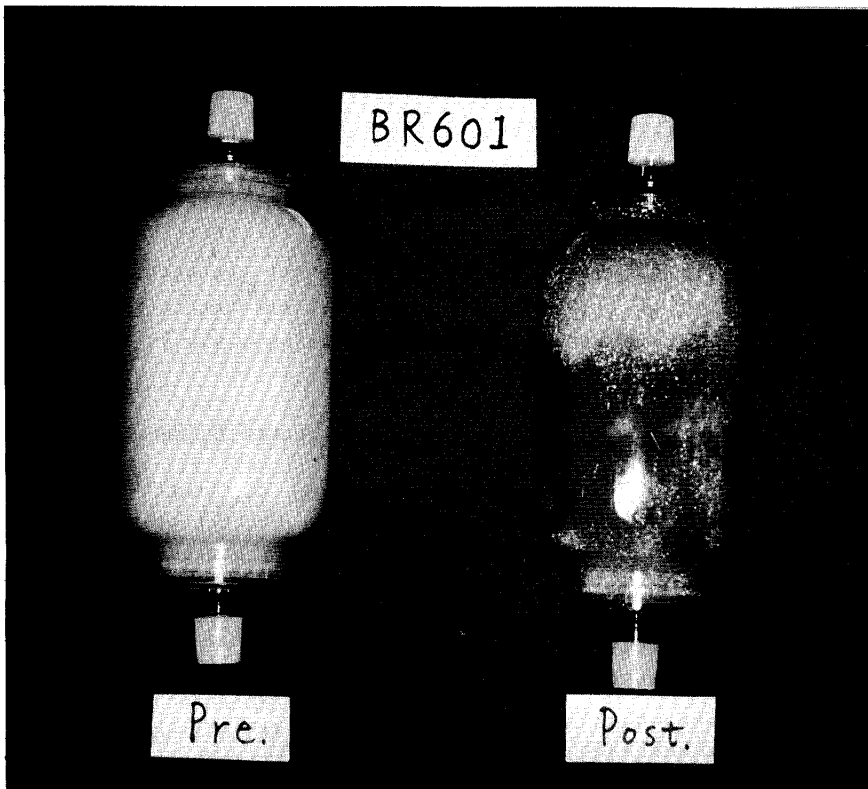
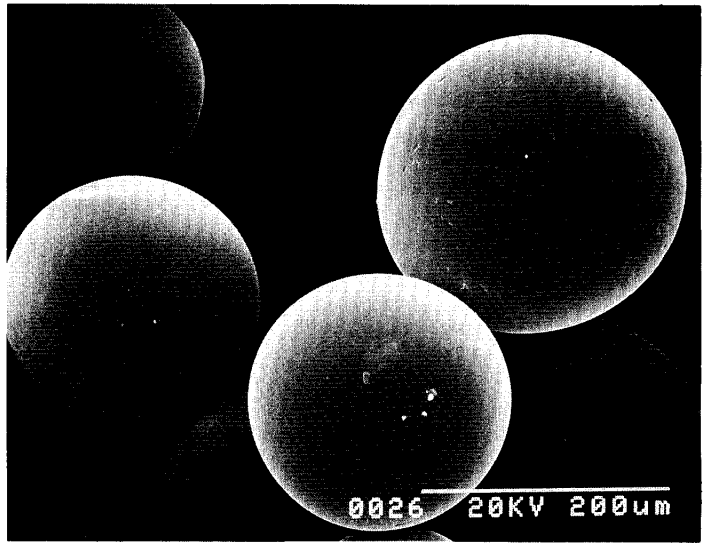
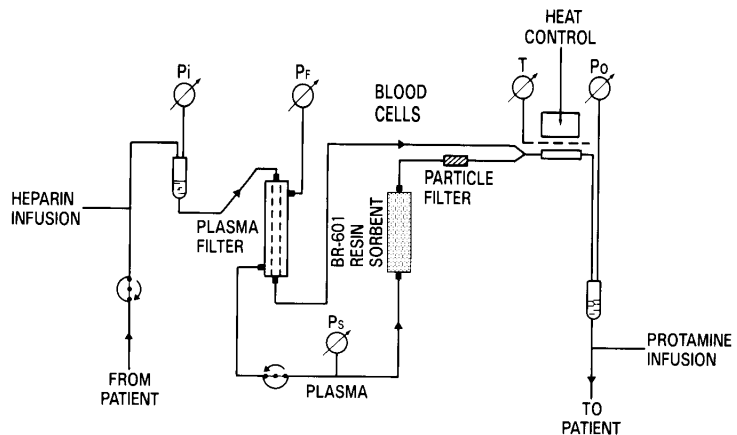

Fig. 2 Column of BR-601 resin before (left) and after (right) plasma perfusion.

Fig. 3 Device for plasma perfusion through BR-601 resin using a membrane separator.



an ammonium radical attached as an exchange radical. As shown in Fig. 1, the resin is in the form of 200- μ m spheres. A cartridge containing 500 g of BR-601 was used for PP (Fig. 2, left). The right side of Fig. 2 shows a column filled with bilirubin at the end of PP.

PE and PP Methods. With respect of PE, a membrane separation method using Plasmaflo (AP-05H, Asahi Medical Co., Japan) was employed in all cases. The flow volume was 100-120 ml/min, and 3 l of plasma were exchanged with 40 units of fresh frozen plasma (about 3200 ml). As for PP, 100-120 ml/min of blood were drawn from each patient, and plasma was separated with a membrane plasma separator at 30 ml/min. The plasma was then passed through a BR-601 resin column and adsorbed continuously and returned to the patient together with blood cells (Fig. 3).

Evaluation of adsorption and removal rates of blood bilirubin and total bile acids. To evaluate the effectiveness of the BR-601 resin column, the rate of adsorption and the rate of removal of blood bilirubin and total bile acids were calculated. The former was calculated according to the following formula :

$$\text{Adsorption rate (\%)} = \left(1 - \frac{B}{A}\right) \times 100,$$

where A = value of plasma before passing through the BR-601 resin column, and B = value of effluent. The adsorption rates were calculated 4 times : after treating 250 ml, 1000 ml, 2000 ml and 3000 ml of plasma. The removal rate was calculated by :

$$\text{Removal rate (\%)} = \left(1 - \frac{A_x}{A_1}\right) \times 100,$$

where A_1 = value at the column inlet after treating 250 ml of plasma, and A_x = value at the column

inlet after treating 1000, 2000 and 3000 ml of plasma. The removal rate at each PE was obtained using the A_1 value at the inlet of the plasmaflo column immediately after the start, and the A_x value just before the end.

Results

Clinical outcome. As shown in Table 1, although improvement in the consciousness level was observed in all cases except case 5, no survival case was obtained due to complicated multiple organ failure. In case 1, hypotension possibly induced by bleeding in the abdomen occurred two days after the operation followed by acute hepatic and renal failure. Hemodialysis together with PE and PP were performed, but with no effect. In case 2, while the degree of coma advanced as far as III, the serum total bilirubin level was 9.5 mg/dl at the start of treatment. Even though the bilirubin level was kept at 15 mg/dl, acute renal failure appeared 47 days postoperatively, and the patient died of multiple organ failure. In case 3, the degree of coma was improved from III to I by PE and PP, and the bilirubin level was kept below 15 mg/dl. However, sudden intra-abdominal bleeding occurred 21 days postoperatively resulting in death. In case 4, although the serum total bilirubin level increased to a peak of 4.0 mg/dl 4 days post-

Table 1 Clinical data of the patients studied

Case	Age, sex	Diagnosis	Operative procedures	Resection of portal vein	Onset of liver failure (POD ^b)	Start of liver support (POD)	Total bil ^a (mg/dl)	Liver Support PE ^b	BR-601 ^b	Coma grade pre-	post-	Complication (POD)	Outcome (POD)
1. T.O.	73, F	Cancer of biliary tract	PD ^a + RHL	Yes	3	3	17.6	2	2	III	II	ARF ^b (8) Hypotension (2)	Expired (14)
2. T.H.	48, M	Cyst-adenocarcinoma of pancreas	TP ^a + Spx ^b + TG ^b	No	18	26	9.5	12	9	III	II	ARDS ^b (5) Leakage (8) GIB ^b (10) ARF (47)	Expired (57)
3. K.K.	66, M	Cancer of gallbladder	PD+ RHL	Yes	5	11	21.5	4	5	III	I	GIB (21) IAB ^b (21)	Expired (22)
4. M.D.	68, F	Cancer of biliary tract	PD+ PH ^b	Yes	13	15	10.5	3	3	IV	III	IAB(11) Leakage (11) ARF (12)	Expired (21)
5. H.S.	43, M	Esophageal varices	AET ^b	No	9mo.	—	15.5	2	9	I	I	Rebleeding	Expired (10mo.)

a: Total bilirubin values just before performing liver support.

b: POD, postoperative days; PE, plasma exchange; BR-601, plasma perfusion through BR-601 resin; PD, pancreaticoduodenectomy; RHL, right hepatic lobectomy; TP, total pancreatectomy; Spx, splenectomy; TG, total gastrectomy; PH, partial hepatectomy; AET, abdominal esophageal transection; ARF, acute renal failure; ARDS, acute respiratory distress syndrome; GIB, gastrointestinal bleeding; IAB, intraabdominal bleeding.

operatively, the patient showed satisfactory recovery until the eleventh postoperative day, when intraabdominal bleeding and leakage at the gastro-pancreatic anastomosis initiated acute hepatic and renal failure. In spite of hemodialysis, PE and PP, the patient died. In case 5, nine months after a transabdominal esophageal transection, cirrhotic liver functions became non-compensatory. After two PE therapy sessions and 9 PP therapy sessions, the bilirubin level was kept at about 15 mg/dl, but the patient died of sudden rupture of esophageal varices. Thus, combined therapy of PE and PP kept bilirubin levels at pretreatment levels and improved consciousness in all cases, but did not improve the bad prognosis due to multiple organ failure.

Adsorption and removal rates of blood bilirubin and total bile acids with BR-601 in PP. The mean values of serum total bilirubin, direct bilirubin and concentration of total bile acids of patients prior to treatment were 15.3 ± 7.0 mg/dl ($n = 11$), 10.6 ± 4.5 mg/dl ($n = 11$) and 35.7 ± 11.2 mol/ml ($n = 3$), respectively. As shown in Fig. 4, al-

though the adsorption rates decreased according to the volume of plasma perfusion, they were still as high as $56.6 \pm 5.5\%$ for total bilirubin, $56.8 \pm 3.6\%$ direct bilirubin and $75.1 \pm 2.2\%$ total bile acids, after treating 3000 ml of plasma. Fig. 5 shows changes in removal rates over time. Removal rates were low at the time of treatment of 1000 ml plasma, but they increased rapidly at the time of 2000 ml to $20.5 \pm 5.2\%$ for total bilirubin, $21.2 \pm 3.8\%$ for direct bilirubin and $16.9 \pm 4.8\%$ for total bile acids. After treating 3000 ml plasma, while no marked increase was observed, the values became $24.5 \pm 5.8\%$, $25.5 \pm 5.8\%$ and $30.9 \pm 8.5\%$, respectively.

Comparison of ability to remove total bilirubin and bile acids between PE and PP. To investigate the possibility of reducing the volume of fresh frozen plasma required for PE, the removal of blood bilirubin and total bile acids was compared between PE after exchanging about 3l of fresh frozen plasma and PP after treating 3l of plasma. As shown in Fig. 6, the removal rates in PE and PP were $30.9 \pm 13.3\%$ and $26.6 \pm$

Fig. 4 Percent absorption of total bilirubin, direct bilirubin, and bile acid during plasma perfusion through BR-601 resin. (n = No. of patients examined).

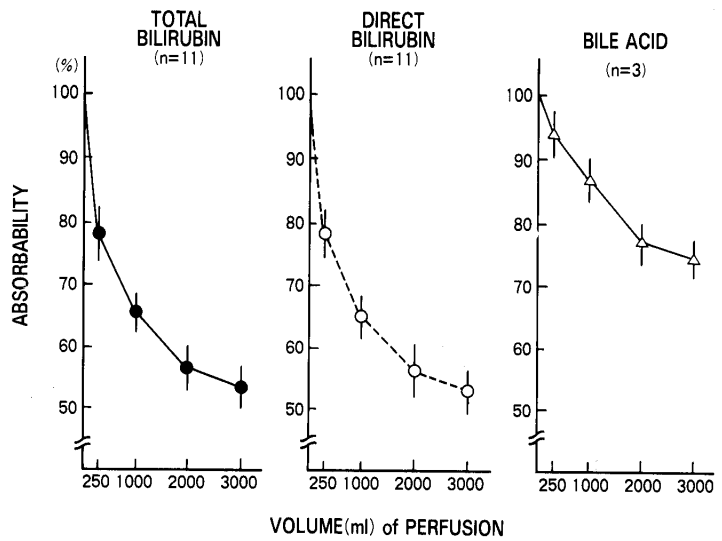

Fig. 5 Percent reduction in total bilirubin, direct bilirubin, and bile acid during plasma perfusion through BR-601 resin. (n = No. of patients examined).

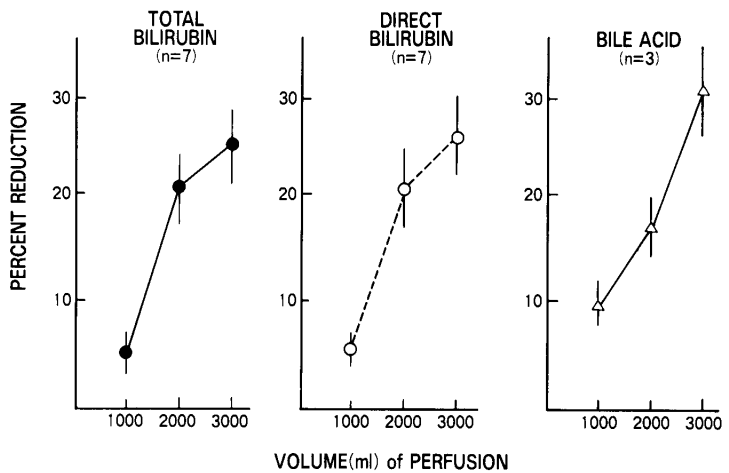
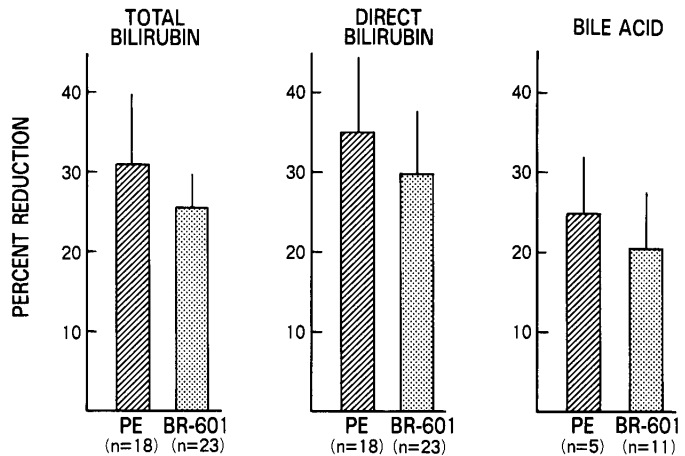

Fig. 6 Comparison of percent reduction in total bilirubin, direct bilirubin, and bile acid between plasma exchange (PE) and plasma perfusion through BR-601 resin (BR-601). (n = No. of patients examined).



6.6% for total bilirubin, $34.5 \pm 12.5\%$ and $29.5 \pm 9.5\%$ for direct bilirubin and $24.2 \pm 8.5\%$ and $19.8 \pm 9.8\%$ for total bile acids, respectively. Thus, the relative removal effects of PP to PE were 86.1% for total bilirubin, 85.5% for direct bilirubin and 81.8% for total bile acids.

Discussion

Recently, the necessity of removing protein-bound substances such as bilirubin which increase in the blood during hepatic failure has been realized (5, 6), and anion exchange resins, such as BR-601 (5), IONEX (7), and PAT resin (8) which show high absorbability toward protein-bound substances, have been developed. The removal rate of total bilirubin by direct hemoperfusion in jaundiced dogs has been shown to be 55% with BR-601 (5), 49% with IONEX (7), and 44% with PAT resin (8).

The present study is the first to be reported of the clinical application of BR-601 to postoperative hepatic failure. Our preliminary investigations showed that plasma perfusion with an anion exchange resin (BR-601) as an artificial liver support system proved to be effective in promoting consciousness in hepatic coma, but did not prove to be satisfactory in improving the survival rate. In the present study, we focused on the removal of bilirubin and bile acids that might be relevant to hepatic coma (5, 6). The removal rate of blood bilirubin by plasma perfusion with BR-601 was 30.9% at the time of treating 3000 ml of plasma. This removal effect is equivalent to 86.1% of that by plasma exchange therapy (exchange volume of 3000 ml), indicating that this method of liver support is effective in reducing toxicity and can satisfactorily replace PE therapy which requires a large amount of fresh plasma.

Our present study clearly indicated that

it is necessary to start artificial liver support at early stages to prevent incidence of multiple organ failure, which influences the prognosis of postoperative hepatic failure. Takenaka *et al.* (3) reported that they predicted the incidence of hepatic failure at an early stage with plasma lecithin cholesterol acyltransferase (LCAT) as an index. They performed PE before the disease advanced to the incompensatory stage, resulting in five survival cases (36%) out of 14. To improve the prognosis of postoperative hepatic failure, we would like to recommend the clinical application of plasma perfusion with BR-601 as an artificial liver support system, to be initiated when the degree of coma is I or II, the total bilirubin value is below 10 mg/dl, the prothrombin time is above 30% and the hepaplastin test is above 30%.

References

1. Bucher NLR and Swaffield MM: Regulation of hepatic regeneration in rats by synergic action of insulin and glucagon. *Proc Natl Acad Sci U.S.A.* (1975) **72**, 1157-1162.
2. Rosen HM, Yoshimura N and Hodgman JM: Plasma amino acid patterns in hepatoencephalopathy of different etiology. *Gastroenterology* (1977) **72**, 483-488.
3. Takenaka K, Kanematsu T, Sugimachi K and Inokuchi K: Serum lecithin cholesterol acyltransferase (LCAT) activity is an accurate predictor of postoperative hepatic failure. *Disease Markers* (1984) **2**, 501-507.
4. Asano E, Ueno K, Higashino Y, Nagakawa T, Miyazaki I, Kobayashi K and Kusada M: Evaluation of plasmapheresis therapy for hepatic failure following surgery for malignant disease of the liver, biliary tract and pancreas; in *Therapeutic Plasmapheresis (II)*, Oda T ed, Schattauer, Stuttgart-New York (1982) pp 415-418.
5. Asanuma Y, Malchesky PS, Smith JW, Zawicki I, Carey WD, Ferguson DR, Hermann RE and Nose Y: Removal of protein-bound toxins from critical care patients. *Clin Toxicol* (1980) **17**, 571-581.
6. Sideman S, Mor L and Brondes JM: Removal of bilirubin by hemoperfusion with ion exchange resins. *Trans Am Soc Artif Intern Organs* (1979) **15**, 497-501.
7. Hamabe S, Idezuki Y, Hamaguchi M, Moriya H, Komoriyama H, Yonaha Y, Watanabe H, Sonoda T, Nogi T, Kimura T, Teramoto K and Tanzawa H:

Application of plasmapheresis in artificial hepatic assist systems; in Therapeutic Plasmapheresis (II), Oda T ed, Schattauer, Stuttgart-New York (1982) pp 335-338.

8. Oomori Y, Ishimaru M, Goto S, Arita A, Inoue S, Mizuta T, Nagao T, Saito H, Kawano N, Morioka Y, Suzuki H, Hasegawa R and Hosoda K: A new artificial liver support apparatus-PAT Resin; in Therapeutic Plasmapheresis (IV), Schattauer, Stuttgart-New York (1984) pp 357-362.

Received: April 3, 1986
Accepted: August 6, 1986

Reprint requests to:

Kenichi Sakagami
First Department of Surgery
Okayama University Medical School
2-5-1 Shikata-cho
Okayama 700, Japan