

Physics

Weights & Measures fields

Okayama University

Year 1997

A new fast rangefinding method based on
a non-mechanical scanning mechanism
and a high-speed image sensor

Mitsuru Baba
Okayama University

Tadataka Konishi
Okayama University

Nobuaki Kobayashi
Okayama University

This paper is posted at eScholarship@OUDIR : Okayama University Digital Information
Repository.

http://escholarship.lib.okayama-u.ac.jp/weights_and_measures/2

A New Fast Ranging Method Based on a Non-Mechanical Scanning Mechanism and a High-Speed Image Sensor

Mitsuru Baba, Tadataka Konishi, Nobuaki Kobayashi

Faculty of Engineering, Okayama University
Tsushima-Naka 3-1-1, Okayama, 700 Japan

Phone 81-86-252-1111 Fax 81-86-255-9136 E-mail:baba@sd.c.it.okayama-u.ac.jp

Abstract - In this paper, we present a new fast ranging method based on a non-mechanical scanning mechanism and a high-speed image sensor. Although the light stripe ranging method often is utilized to measure three dimensional shape of an object, it is difficult to acquire dense range data at high-speed with conventional light stripe rangefinders. We proposed a fast ranging method based on two new ideas unlike conventional methods: (1) to move a parabolic light pattern onto the object by means of a non-mechanical mechanism; (2) to detect a true peak value using a high-speed image sensor. We have designed and built a prototype rangefinder. The rangefinder was able to acquire three-dimensional position at 500ns which is faster than conventional rangefinders. As a result, the proposed method is effective for high-speed three-dimensional measurement.

I. INTRODUCTION

Rangefinding is an important issue in many three-dimensional sensing applications[1]. Light stripe ranging methods are a common approach in industrial application. Conventional light stripe ranging methods operate in the following manner: A light stripe is projected onto an object, a light stripe image is acquired by image sensor, the position of the projected light stripe is extracted from the image, the stripe is moved slightly by a scanning mechanism, and the process is repeated until the entire scene is scanned.

Range acquisition time using this method depends upon a scanning time of the light stripe and an image acquisition time. Conventional light stripe rangefinders often make

use of both mechanical scanning mechanisms such as a rotating mirror and image sensors such as a video camera. In the case of image sensors, specially designed high-speed image sensor have been developed in order to reduce the data acquisition time[2]-[5]. However, mechanical scanning methods are almost always used with the result that it is difficult to increase the scanning rate due to the inertia of mechanical parts[6]. The actualization of very fast rangefinders requires the consideration of both the improvement of scanning mechanisms and the reduction of the image sampling interval.

We proposed a fast ranging method based on the following two new ideas unlike conventional methods:

- (1) We devised a new non-mechanical scanning mechanism of the light stripe, which moves a parabolic light pattern onto the object by means of a non-mechanical mechanism
- (2) We designed a new high-speed image sensor, which detects a true peak value of the light pattern using an analog parallel signal processing.

This paper describes the principle of the proposed scanning mechanism and the high-speed sensor, system configuration of the ranging method and experimental results.

II. A NEW SCANNING MECHANISM

A. Mechanism

Fig.1 shows examples of the conventional scanning mechanism of the light stripe[1]. These methods usually scan the light stripe by rotating the light source directly or by making the light stripe reflect by a rotating mirror. The

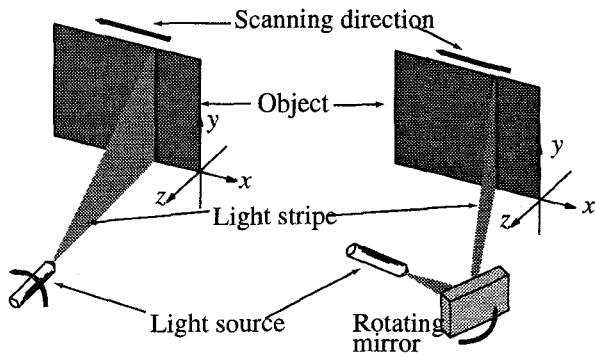

Fig.1. Conventional scanning mechanism of the light stripe.

scanning rate of these mechanical methods is limited by the inertia of the rotating parts. For example, the maximum frame rate of a current high-speed camera is about 10000 frames per second and the sampling time of this rate is about 1.7kHz. Therefore it is difficult to acquire the three dimensional data at a higher speed by use of the mechanical methods.

We propose to overcome this limitation by devising a non-mechanical scanning method. Fig.2 shows the principle of a proposed non-mechanical scanning method. The method uses two or three light sources. In this paper, we explain the case of two light sources 1 and 2. The principle of the case of three light sources is similar to that of two light sources. The case of three light sources is wider in moving range of the light stripe than that of two light sources. The light intensity of each light source is able to

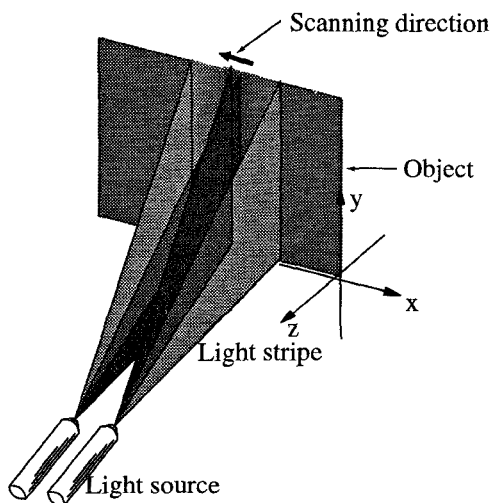

Fig.2. Proposed scanning mechanism of the light stripe.

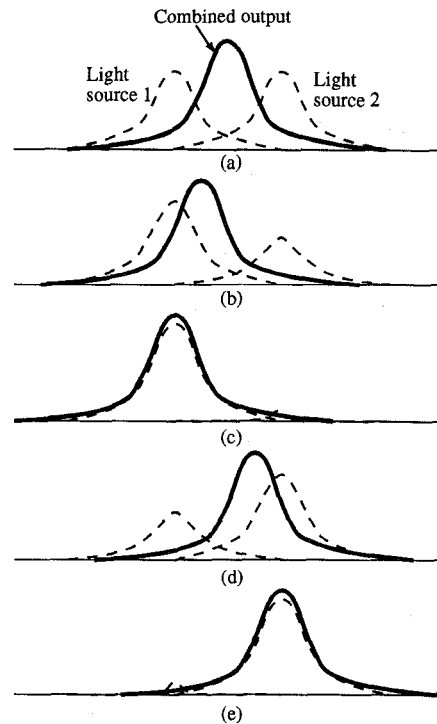

Fig.3. Moving mechanism of the proposed method

change by adjusting the voltage applying each light source.

Fig.3 shows the moving mechanism of the proposed method. The proposed scanning mechanism works as follows:

- (1) By adjusting the distance between two stripes, we can generate a combined parabolic output with a single peak which is shown in terms of a solid line in Fig.3(a).
- (2) As shown in Fig.3(a), when the light intensity of light source 1 and light source 2 is the same, the peak position of the combined output is the middle point of both the peak position of light source 1 and that of light source 2.
- (3) As shown in Fig.3(b) and (c), lowering the light intensity of the light source 2, the peak position of the combined output moves to the side of the light source 1. When the intensity of light source 2 is zero, the peak position of the combined output coincides with that of light source 1.
- (4) In contrast, lowering the intensity of the light source 1, the combined output moves to the side of the light

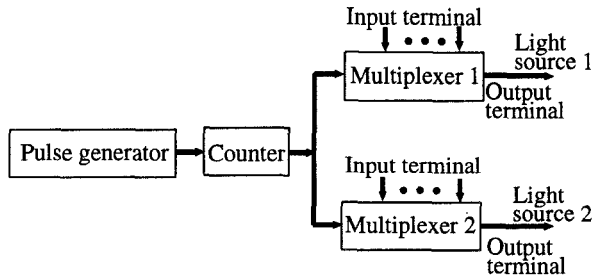

Fig.4. Control circuit of the proposed scanning mechanism.

source 1, as shown in Fig.2(d) and (e).

In this method, the adjusting of the light stripe generating device mechanically or the moving of mechanical parts is unnecessary, which results in a higher scanning rate than conventional methods. This method can scan at the sampling time from 10kHz to 1MHz.

B. Control circuit

Fig.4 shows the block diagram of a control circuit for scanning of the light stripe. The control circuit consists of a pulse generator, counter and two multiplexers. The pulse generator generates a pulse for scanning the light stripe. The counter counts the pulse generated by the pulse generator. The input terminals of the multiplexer is connected to a different voltage, respectively. According to the value of the counter output, the output terminal of the multiplexer switches the input voltage, and outputs a different voltage. By altering the combination of the output terminal of the counter and input terminal of the multiplexer, the multiplexer 1 and multiplexer 2 differ in the output voltage. Outputs of two multiplexers are inputted to two light sources, respectively and we can shift the light stripe by an adjustment of the output voltage. The combined output of two light sources shifts at intervals of the pulse repetition rate of the pulse generator.

C. Test circuitry

We designed and constructed a test circuitry by use of the discrete IC devices. The light sources use light emitting diode(LED). In this circuitry, the number of input terminals of the multiplexer is 15. The circuit's maximum pulse repetition rate is 1MHz, leaving about 1 microsecond between pulses.

D. Characteristics

Fig.5(a)-(e) show measuring results of the intensity distribution of a combined output, light source 1 and light source 2. In this experiment, the output of the light source is received by CCD(charge coupled device). From Fig.4, it is shown that the peak position of the combined output (shown by a solid line in the figure) shifts according to a change in the intensity of the light source 1 and the light source 2 (shown by a broken line). The maximum sampling rate of the proposed method is 10MHz or more, and it is much higher than that of a conventional mechanical method which is 1KHz - 10KHz.

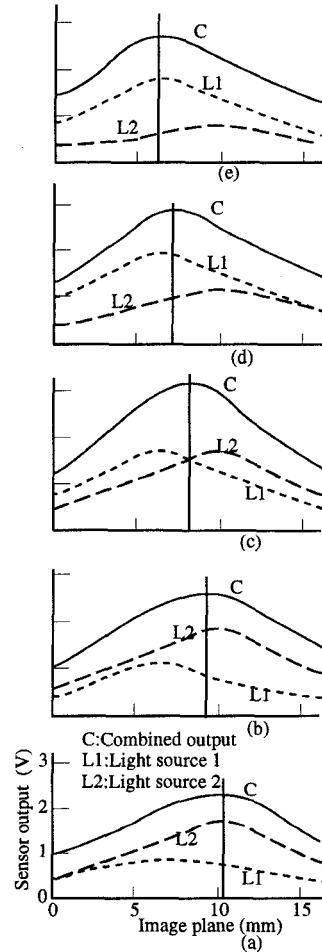

Fig.5. Measuring results of the intensity of a combined output, light source 1 and light source 2 in the proposed method.

III. A NEW HIGH-SPEED IMAGE SENSOR

A. Principle

We devised a new high-speed image sensor corresponding to the proposed non-mechanical scanning method. Conventional sensors such as CCD or PSD (Position Sensitive Detector) are not suitable for the proposed scanning method. CCD has difficulty in acquiring peak position data at high-speed due to the scanning time of the analog shift register. Although PSD can acquire the light stripe position at high-speed, PSD is limited to small size and is subject to significant position measurement errors arising from background light.

Fig.6 shows image plane of the proposed high-speed image sensor. The proposed high-speed image sensor is array type and consists of scores of sensor array units which are a small number of photovoltaic sensors.

Fig.7 shows a principle of detecting peak position of the light stripe by the proposed high-speed image sensor. The

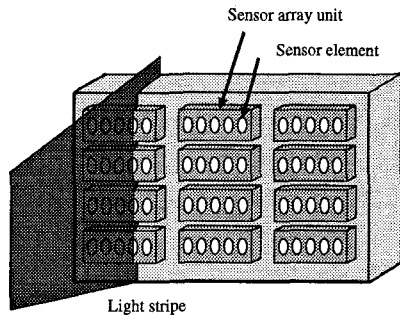

Fig.6. Image plane of the proposed high-speed image sensor.

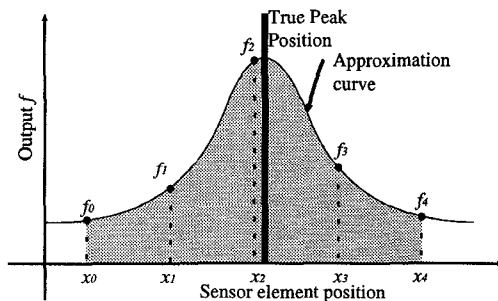

Fig.7. Principle of the detecting peak position of the light stripe by the proposed high-speed image sensor.

solid line in the figure shows a output distribution of a sensor array unit. x_i is position in x-coordinate direction of i -th photovoltaic sensor from the left. f_i is output of i -th photovoltaic sensor.

Let F be a total light stripe intensity which is received by sensor array, and let P be a first order moment of light stripe intensity with respect to X coordinate direction. Then,

$$X = P / F \quad (1)$$

X true peak position of the light stripe is defined by Eq.(1).

We calculate P and F by means of numerical integration as shown in Eq.(2) and Eq.(3).

$$\begin{aligned} F &= \int f_i dx \\ &= \frac{3}{8} h \{0.6f_0 + 1.8f_1 + 1.8f_2 + 1.4f_3 + 0.8f_4\} \quad (2) \end{aligned}$$

$$\begin{aligned} P &= \int x_i f_i dx \\ &= \frac{3}{8} h \{0.3f_0 + 2.7f_1 + 4.5f_2 + 4.9f_3 + 3.6f_4\} \quad (3) \end{aligned}$$

$$h = (x_4 - x_0) / 5 = 0.8 \quad (4)$$

We determined values of Eq.(2) and Eq.(3) by use of only an analog circuit by designing a special circuitry.

B. Circuitry

Fig.8 illustrates a circuitry of detecting the peak position by means of numerical integration. The important consideration in this circuitry is to embody both analog circuitry which can integrate numerically and parallel signal processing. We successfully achieved the method with operational amplifier. Essential components in this circuitry include a current-voltage converting unit, an adding unit, an integrating unit and a dividing unit. When the light stripe are inputted to sensor array, the circuitry converts a current from photovoltaic to a voltage. The adding unit and integrating unit outputted F and P , respectively. The circuitry actualizes the numerical integrating process by adjusting the gain of each operational amplifier. Finally, dividing unit output X true peak position of the light stripe.

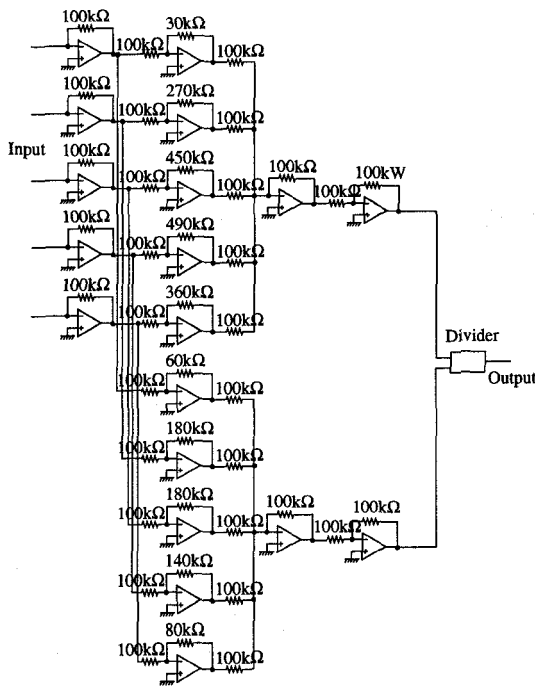

Fig.8. Circuitry of the detecting the peak position by means of numerical integration.

C. Characteristics

Fig.9 shows the peak position outputted by the proposed sensor versus actual position. The procedure of measurement of the actual positions first sets the high-speed sensor and light source to precision translation stages, and moves slight source. In this figure, the solid line is drawn

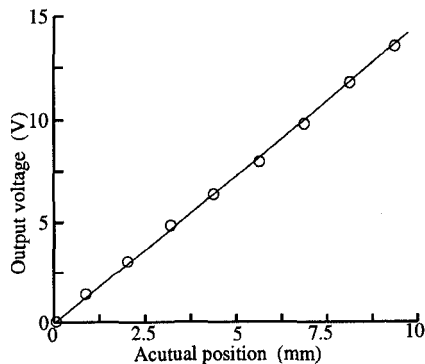

Fig.9. Measuring result of the peak position of the light stripe by the proposed sensor versus actual position

by the method of least squares. The deviation of measured data from linearity is within about 2.7%.

We measured the response by inputting a high frequency pulse to high-speed image sensor and by checking whether the output of the high-image sensor follows the input pulse or not. As a result, we made sure that the high-speed image sensor can be used in the input pulse frequency range of 0 to 2MHz. Therefore, this response is equivalent to 2MHz of measuring frequency and is proven to high-speed compared to a conventional image sensor.

VI. EXPERIMENT

A. System Configuration

We have designed and built a prototype rangefinding system. Fig.10 shows a schematic diagram of the system. This system consists of a non-mechanical light stripe scanning device, a lens system, a high-speed image sensor system, a signal processing circuit and a measuring computer. The scanning device uses two semiconductor diode lasers. The lens system is used in order to adjust the measuring area of both x-direction and y-direction. The high-speed image sensor consists of 6 x 6 sensor array units which are composed of five photo diodes. The signal processing unit consists of a multiplexer, an A/D converter, a memory unit and an interface circuit. The measuring computer inputted the data from signal processing unit, and calculated three dimensional position of the object

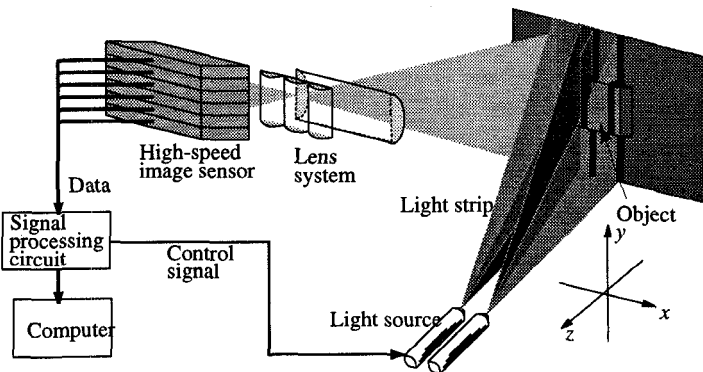

Fig.10. System configuration of the experimental setup

B. Measuring Procedure

As shown in Fig.10, the high-speed image sensor is aligned along the z-axis with the center of the lens system. The proposed light stripe scanning device is located at a distance of 100mm to the right of the image sensor (along the positive x-axis) which sends out light stripes at variable angles relative to the x-axis. The distance between the lens system and the object is 60mm and that between the image sensor and the object is 120mm.

C. Measuring Results

Fig.11 shows the measuring results of the object which is formed by stacking two prisms. Maximum measuring errors is within 0.210mm and the sampling time is 1 microsecond. The sampling time is limited to the acquisition time of the high-speed image sensor, because the sampling time of the high-speed image sensor is 1 microsecond, and that of the scanning device is 0.2 microseconds or less. Thereby, it is necessary to develop an ultra high-speed image sensor for a very fast rangefinder.

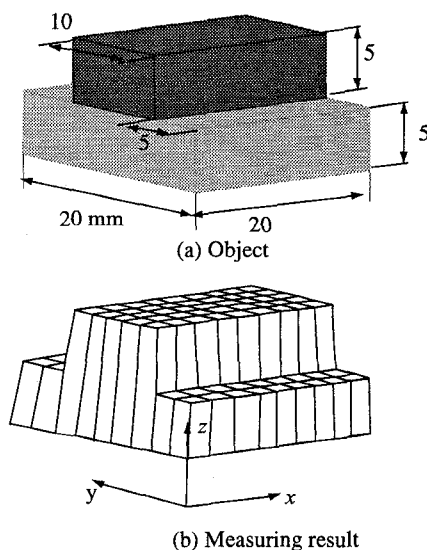

Fig.11. Shape measuring result of the proposed method

V. CONCLUSIONS

In this paper, we present a new fast rangefinding method based on a non-mechanical scanning mechanism and a high-speed image sensor. We proposed a fast rangefinding method based on two new ideas unlike conventional methods: (1) to move a parabolic light pattern onto the object by means of a non-mechanical mechanism; (2) to detect a true peak value using an analog parallel image sensor.

First, the proposed scanning mechanism works as follows: (1) The method projects three thick stripes on the object. (2) By adjusting the distance between the three stripes, a combined parabolic output with a single peak is generated. (3) Lowering the intensity of one side light stripe, the peak position of the combined output moves to the lowered side of the intensity.

Secondly, the proposed image sensor which is composed of sensor elements detects the sensor element outputting maximum value by a parallel processing technique. The sensor interpolates between the output of the sensor element outputting maximum value and the outputs of adjacent sensor elements. And the sensor calculates the true peak using only an analog circuit.

We have designed and built a prototype rangefinder. The rangefinder was able to acquire three-dimensional position at 500ns which is faster than conventional rangefinders. As a result, the proposed method is effective for high-speed three-dimensional measurement.

REFERENCES

- [1] Jorge.L.C.Sanz, ed. *Advances in Machine Vision*. 1989, New York.
- [2] Takeo Kanade, A.G., Lichard Carley, Integrated sensor and rangefinding analog processor, *IEEE Journal of Solid-State Circuits*,26(3),1991
- [3] Srinivasan Parthasarathy Kasuo Araki and Yukio Sato, High speed rangefinder. *SPIE*,850(Optics,Illumination and Image Sensing for Machine Vision II),184-188,1987
- [4] T.Kida, K.Sato and S.Inokuchi. Realtime range imaging sensor. *Proceedings 5th Sensing Forum*,91-95,1988,In Japanese
- [5] Takeo Kanade, A.G., Lichard Carley, A very fast VLSI rangefinder. *Proceedings of the 1991 IEEE International Conference on Robotics and Automation*, 1991,1322-1329.