

*Chemistry**Analytical Chemistry fields*

Okayama University

Year 2004

Flow injection spectrophotometry
coupled with a crushed barium sulfate
reactor column for the determination of
sulfate ion in water samples

Rodjana Burakham*

Keiro Higuchi[†]Mitsuko Oshima[‡]

Kate Grudpan**

Shoji Motomizu^{††}

*Department of Chemistry, Faculty of Science, Chiang Mai University

[†]FIA Instruments Co., Ltd.

[‡]Department of Chemistry, Faculty of Science, Okayama University, oshimam@cc.okayama-u.ac.jp

**Department of Chemistry, Faculty of Science, Chiang Mai University

^{††}Department of Chemistry, Faculty of Science, Okayama University, motomizu@cc.okayama-u.ac.jp

This paper is posted at eScholarship@OUDIR : Okayama University Digital Information Repository.

http://escholarship.lib.okayama-u.ac.jp/analytical_chemistry/22

Flow Injection Spectrophotometry Coupled with a Crushed Barium Sulfate

Reactor Column for the Determination of Sulfate Ion in Water Samples[☆]

([☆]paper presented at the 12th International Conference on Flow Injection Analysis, Venezuela, 7-13 December 2003)

Rodjana Burakham^a, Keiro Higuchi^b, Mitsuko Oshima^c, Kate Grudpan^a and Shoji Motomizu^{c*}

^aDepartment of Chemistry, Faculty of Science, Chiang Mai University, Chiang Mai 50200 Thailand

^bFIA Instruments Co., Ltd., 6-15-9 Toshima, Kita-ku, Tokyo 114-0003 Japan

^cDepartment of Chemistry, Faculty of Science, Okayama University, 3-1-1 Tsushima-naka, Okayama 700-8530 Japan

Abstract

A new type of a reactor column, a crushed BaSO₄ reactor column used for the flow injection spectrophotometric determination of sulfate using the exchange reaction of sulfate and barium-dimethylsulfonazo III is proposed. The column is very simple and economical. It can be continuously used for 8 h before washing with water for reuse of at least 1 month. The procedure is sensitive. Application to various water samples was demonstrated.

Keywords: sulfate, dimethylsulfonazo III, on-line reactor column, flow injection analysis, spectrophotometry

* Corresponding author. Tel. +81-86-251-7846

E-mail address: motomizu@cc.okayama-u.ac.jp (S. Motomizu)

1. Introduction

Sulfate ion, one of the major components in natural waters, often associates in monitoring natural waters. The determination of sulfate ion is also of interest with respect to the problems of acid rain and water pollution. Several methods have been reported so far for the determination of sulfate ion; for examples, ion chromatography [1-2], flow injection analysis (FIA) [3-8] and sequential injection analysis (SIA) [9-11]. Conventional methods for the determination of sulfate ion in water samples are commonly based on formation of a barium sulfate suspension [12] and an anion exchange/spectrophotometry with either barium chromate [13-14] or barium chloranilate [14] as a solid reagent. A reaction unit was introduced into a flow injection method to accelerate the efficiency of the solid-liquid reaction [16]. However, the sensitivity was less enough for ppm levels of sulfate.

Recently, some reactor columns promoting the efficiency of the solid-liquid reaction have been developed. Ueno et al. proposed an on-line reactor column packed with spherical beads of regenerated cellulose mixing with barium chloranilate particles for the flow injection determination of sulfate [17]. Sakuragawa et al. proposed an on-line reactor column packed with solid barium chromate [18]: sulfate ion at the concentration range of 0.5 to 5 mg/l in water samples was determined. The detection limit, however, was about 0.5 mg/l, which was not sensitive enough for trace analyses.

Toei and his colleagues reported the sensitive determination method for sulfate ion by FIA using the barium chelate of sulfonazo III and dimethylsulfonazo III (DMS III) [19]. In this system, high sensitivity was achieved. Later, the detection limit, as low as 0.2 mg/l, was improved by Toei and his colleagues by using the barium-DMS III chelate (Ba-DMS III) method which required the carrier solution being saturation with BaSO₄ [20]. However, the addition of BaSO₄ to the carrier solution resulted in the negative peaks, which limited the limit of detection of sulfate ion by the FIA method, when sulfate ion presents at low concentrations of less than 1 mg/l of sulfate ion. Furthermore, several line filters must be installed in the flow line to prevent the precipitate of BaSO₄ entering into the flow cell.

Various kinds of on-line reactor columns have been proposed for improving the efficiency of the exchange reaction. They include a polytetrafluoroethylene (PTFE) tubing without packing material, a glass column packed with glass beads or with BaSO₄-immobilized glass beads [21]. By using the BaSO₄-immobilized column, the sensitivity was enhanced and the reproducibility was greatly improved. However, the procedure is rather complicate and time consuming.

In this work, a very simple reactor column, packed with crushed BaSO₄, for determination of sulfate ion was developed. The detection method was similar to the previous reports [12, 21,22] based on the exchange reaction between sulfate ion and Ba-DMS III resulting

in decreasing in absorbance (662 nm). The proposed reactor column was found to be economical and very effective for improving the limit of detection.

2. Experimental

2.1 Chemicals and reagents

All of the reagents used in this work were of an analytical reagent grade. Water purified with a Milli-Q system (Elix 3/ Milli-Q Element, Nihon Millipore) was used throughout the experiments. A stock solution (1000 mg/l) of sulfate ion was prepared by dissolving 1.815 g of potassium sulfate in water and diluting to the mark of a 1000 ml volumetric flask with water. Working standards were freshly prepared by appropriate dilution of the stock solution. The stock reagent solution was prepared similar to that of Yang et al. [21, 22] as follows: 4.5 ml of a 10^{-2} mol/l DMS III solution (DMS III: Tokyo Kasei, TCI-Ace grade; Tokyo), 5 ml of a 1 mol/l potassium nitrate, 3.2 ml of a 10^{-2} mol/l barium chloride solution, 5 ml of a 0.1 mol/l chloroacetate buffer (pH 2.9) and 800 ml of ethanol were transferred into a 1 l volumetric flask and mixed, and the solution was diluted to the mark with water. Before use, the reagent solution was filtered through a 0.45 μm membrane filter.

The crushed BaSO_4 reactor column was prepared by packing crushed BaSO_4 (particle size: about 90 μm) into a glass column (2 mm i.d. x 15 cm).

2.2 Flow injection system

Fig. 1 depicts the FI manifold with a crushed BaSO_4 reactor column. A standard/sample solution containing sulfate ion is injected via an injection valve (SNK, Japan) (200 μl injection volume) into the carrier stream (water) and then passed a cation exchange column, made of glass tube (2 mm i.d. x 15 cm), packed with cation exchange resin (Na^+ -type IR124T, Amberlite). The stream merges with the stream of reagent solution containing Ba-DMS III before entering the crushed BaSO_4 reactor column. The exchange reaction between sulfate ion and Ba-DMS III proceeds during flowing in the reactor column. Absorbance (at 662 nm) is continuously monitored by a spectrophotometer (UV-8010, Tosoh, Japan) connecting to a signal recording FIA monitor/data processing apparatus (F.I.A. Instruments, Japan). Change (decrease) in the absorbance is used for the indirect determination of sulfate ion by plotting a calibration graph of peak height vs. sulfate concentration.

3. Results and discussion

Investigation on the FI system using the crushed BaSO_4 reactor column was made by injection the sulfate standard solutions into the FI system, shown in Fig.1, without CEC. By using the stock reagent solution as described above (and in the ref. 21, 22) (4.5×10^{-5} mol/l DMS III, 3.15×10^{-5} mol/l BaCl_2 , 5×10^{-3} mol/l KNO_3 , 80% (v/v) ethanol and 2×10^{-3} mol/l chloroacetate buffer pH 2.9), air bubbles were observed in the flow system. This could be due to that the high

ethanol content (80%(v/v)) in the reagent solution stream may produce heat when merging with the other stream (water carrier). As a result, the reagent solution was diluted with water. It was found that no air bubble when the ratio of the stock reagent solution:water being 3:1. This dilute reagent solution would also offer economical benefit.

The stability of the reactor column was tested by repeated injection of 1 mg/l sulfate solution with the frequency of 40 injections/h. After about 12 h (or 488 injections), change in the baseline level was observed (see Fig. 2). The relative standard deviation (RSD%) of the peak heights before the baseline change was found to be 1.4. This indicates that stability was within 12 h. The column was cleaned by passing water through the column for 1 h. The baseline absorbance was back at the same level as started. The column was then continued for the test with the same procedure. The recovered column was observed to be stable for about other 10 h (or 374 injections, with the RSD of the peak heights of 1.7%). The crushed BaSO₄ column might associate with saturation of BaSO₄ although the flow passes the column in very short period. The mechanism might involve in solubilization or just a powder release: this would be of interest for further investigation. From the study, it is then recommended that for practical use, such a reactor column can be used for 8 h before cleaning with water. It was found that the column could be used at least 1 month with the unchanged sensitivity and reproducibility if such the above procedure is treated.

The analytical characteristics of the proposed reactor column (the crushed BaSO₄ column) was investigated together with the latest developed reactor column, BaSO₄-immobilized glass beads [21]. The results are summarized in Table 1. It can be seen that the FI system with crushed BaSO₄ column offers better sensitivity. The reagent solution used in the system composed of a mixture with lower concentrations of reagents.

By using the proposed FI system with the crushed BaSO₄ reactor column, the effect of various ions commonly found in water samples were examined. The studied foreign ions are K⁺, Na⁺, NH₄⁺, Ca²⁺, Mg²⁺, Al³⁺, Cl⁻, NO₃⁻, CO₃²⁻, PO₄³⁻ and SiO₃²⁻. A foreign ion is considered to interfere with the determination of sulfate ion when it gives a relative error of more than 5%. The results indicate that the presence of most common ions did not interfere with the determination of sulfate ion in river water samples. However, calcium ion interferes severely with the determination of sulfate ion. Usually, in natural waters, relatively large amounts of metal ions, such as alkali and alkaline earth metal ions, are present, and some of them can interfere with the determination of sulfate ion, because the metal ions can react with DMS III to form chelates. Therefore, Nakashima et al [20] installed a cation exchange (Hydrogen (H)-type, 8-15 cm length) column just after a sample injection valve: for 10 mg/l sulfate ion, 20 mg/l of Ca²⁺, 30 mg/l of Mg²⁺ and NH₄⁺, 50 mg/l of Na⁺, 80 mg/l of K⁺ and 100 mg/l of commonly existing anions did not interfere with the determination. However, some of natural waters like

river and lake waters contain Ca^{2+} and Mg^{2+} ions of larger amounts than those examined by Nakashima et al. In the present work, two kinds of cation exchanger column (CEC) were examined; one is the H-type, the other the Na-type CEC. It is found clearly that larger amounts of Ca^{2+} , Mg^{2+} and other metal ions did not interfere with the determination when the Na-type CEC was used. By using the system with Na-type CEC, the better suppressive effect was obtained for calcium ion. For the determinations of sulfate ion in real samples, Na-type CEC was installed.

Application of the proposed FI system with crushed BaSO_4 column to the tap, river and mineral drinking water samples was demonstrated. The results are summarized in Table 2. Good recoveries indicate that the proposed method is not affected by the various ions existing in such water samples.

4. Conclusion

A new type of reactor column, a crushed BaSO_4 column, which is very simple used in a FI spectrophotometric system for the determination of sulfate ion is proposed. The detection based on the exchange reaction of sulfate and Ba-DMS III. The column can be used continuously for 8 h before cleaning with water and can be reused for at least one month. This is very economical. The system also provide good sensitivity (with detection limit of 0.03 mg/l).

Acknowledgements

We thank Ms. Akiko Inoue and Mr. Ryuzi Yamazaki of Tokyo Kasei Kogyo Co. Ltd. for their valuable discussion and assistance throughout this work. The Ministry of University Affairs, Thailand, and the Postgraduate Education and Research Program in Chemistry (PERCH) are gratefully acknowledged for the scholarship to R.B. This work was supported partly by a Grant-in-Aid for Scientific Research (B) (No. 13440220) from the Japan Society for Promotion of Science (JSPS).

References

- [1] Y. Zuo and H. Chen, *Talanta*, 59 (2003) 875.
- [2] L.E. Vanatta, D.E. Coleman and A. Woodruff, *J. Chromatogr.A*, 997 (2003) 269.
- [3] H. Hara, G. Horvai and E. Pungor, *Analyst*, 113 (1988) 1817.
- [4] A. Kojlo, J. Michalowski and M. Trojanowica, *Anal. Chim. Acta*, 228 (1990) 287.
- [5] M. Karlsson, J.A. Persson and J. Moller, *Anal. Chim. Acta*, 224 (1991) 109.
- [6] S. Fernandez-Band, P. Linares, M.D. Luque de Castro and M. Valcarcel, *Analyst*, 116 (1991) 305.
- [7] M.M.S. Filha, B.F. Reis, F.J. Krug, C.H. Collins and N. Baccan, *Talanta*, 40 (1993) 1529.
- [8] R.E. Santelli, P.R.S. Lopes, R.C.L. Santelli and A.D.L.R. Wagener, *Anal. Chim. Acta*, 300 (1995) 149.
- [9] J.F. van Staden and R.E. Taljaard, *Anal. Chim. Acta*, 331 (1996) 271.
- [10] J.E. van Staden and Taljaard, *Fresenius J. Anal. Chem.*, 357 (1997) 577.
- [11] A. Rius, M.P. Callao and F.X. Rius, *Analyst*, 122 (1997) 737.
- [12] F.J. Krug, H.B. Filho, E.A.G. Zagatto and S.S. Jorgensen, *Analyst*, 102 (1997) 503.
- [13] I. Iwasaki, S. Utsumi, T. Tarutani and T. Ozawa, *Bull. Chem. Soc. Jpn.*, 30 (1957) 847.
- [14] Japanese Industrial Standard 1993, K0102.
- [15] R.J. Bertolacini and J.E. Barney II, *Anal. Chem.*, 29 (1957) 281.

- [16] J. Toei, *Analyst*, 112 (1987) 1067.
- [17] K. Ueno, F. Sagara, K. Higashi, K. Yakata, I. Yoshida and D. Ishii, *Anal. Chim. Acta*, 261 (1992) 241.
- [18] A. Sakuragawa, S. Nakayama and T. Okutani, *Anal. Sci.*, 10 (1994) 77.
- [19] O. Kondo, H. Miyata and K. Toei, *Anal. Chim. Acta*, 134 (1982) 353.
- [20] S. Nakashima, M. Yagi, M. Zenki, M. Doi and K. Toei, *Fresenius Z Anal. Chem.*, 317 (1984) 29.
- [21] Y. Yang, X. Zhang, T. Korenaga and K. Higuchi, *Talanta*, 45 (1997) 445.
- [22] Y. Yang, X. Zhang and T. Korenaga, *Anal. Sci.*, 13 (1997) 397.
- [23] J.C. Miller, J.N. Miller, *Statistics for Analytical Chemistry*, 3rd ed, Ellis Horwood, West Sussex, 1993.

List of Figure Captions

Fig. 1 FI system using a crushed BaSO₄ reactor column for the determination of sulfate ion: C, carrier solution; R, reagent solution; P, double plunger micro pump; V, sample injection valve; CEC, cation exchange column; RC, crushed BaSO₄ reactor column; D, detector; W, waste

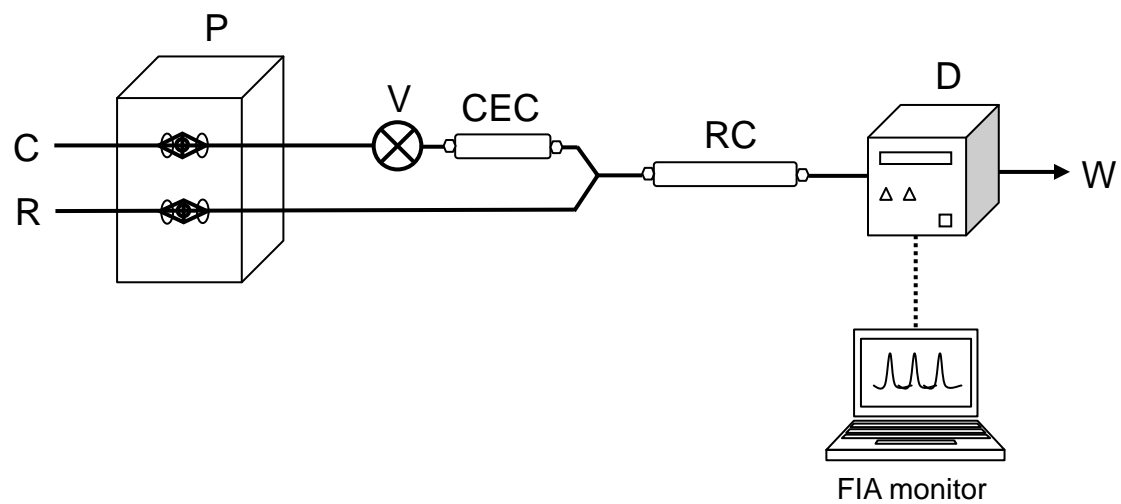

Fig. 1 FI system using a crushed BaSO₄ reactor column for the determination of sulfate ion: C, carrier solution; R, reagent solution; P, double plunger micro pump; V, sample injection valve; CEC, cation exchange column; RC, crushed BaSO₄ reactor column; D, detector; W, waste

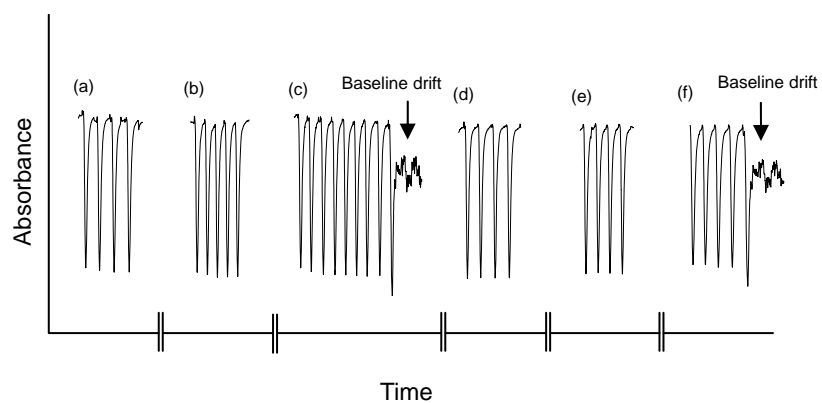

Fig. 2 Stability study by repeated injections of 1 mg/l SO_4^{2-}

(a)-(c) The first 12 h (488 injections): see the drift baseline

(d)-(f) The other 10 h (374 injections) after cleaning

Table 1 Selected conditions and analytical characteristics for sulfate determination by using FI systems

| parameters | BaSO ₄ -immobilized glass bead reactor column (followed the ref.21) | crushed BaSO ₄ reactor column (the present work) |
|------------------------|---|--|
| reagent | 4.5 x 10 ⁻⁵ mol/l DMS III + | 3 x 10 ⁻⁵ mol/l DMS III + |
| solution | 3.15 x 10 ⁻⁵ mol/l BaCl ₂ + 5 mol/l KNO ₃ + 80% ethanol + 2 x 10 ⁻³ mol/l chloroacetate buffer (pH 2.8) | 2.36 x 10 ⁻⁵ mol/l BaCl ₂ + 3.75 mol/l KNO ₃ + 60% ethanol + 1.5 x 10 ⁻³ mol/l chloroacetate buffer (pH 2.8) |
| carrier | | water |
| sample volume | | 200 µl |
| total flow rate | | 1.5 ml/min |
| detection | 662 nm (8 µl, 10 mm path length) | |
| linear range (mg/l) | 0.4 -2.0 | |
| LOD* (µg/l) | 50 | 30 |
| precision (n=20, RSD%) | 0.57 (2 mg/l SO ₄ ²⁻) | 1.12 (1.2 mg/l SO ₄ ²⁻) |

*3 times of standard deviation of the blank [23]

Table 2 Analysis of real water samples for sulfate by the proposed procedure with crushed BaSO₄

| sample | dilution factor | SO ₄ ²⁻ added (mg/l) | SO ₄ ²⁻ found (mg/l) | recovery (%) | SO ₄ ²⁻ found in sample (mg/l) |
|--------------------------|-----------------|--|--|--------------|--|
| Tap water 1 | 10 | 0 | 0.80 | - | 8.04 |
| | | 0.50 | 1.30 | 100 | |
| | | 1.00 | 1.81 | 101 | |
| Tap water 2 | 10 | 0 | 0.80 | - | 8.02 |
| | | 0.50 | 1.30 | 100 | |
| | | 1.00 | 1.83 | 103 | |
| Tap water 3 | 10 | 0 | 0.79 | - | 7.94 |
| | | 0.50 | 1.27 | 96 | |
| | | 1.00 | 1.80 | 101 | |
| Mineral drinking water 1 | 20 | 0 | 0.43 | - | 8.64 |
| | | 0.50 | 0.91 | 96 | |
| | | 1.00 | 1.44 | 101 | |
| Mineral drinking water 2 | 16 | 0 | 0.76 | - | 12.22 |
| | | 0.50 | 1.29 | 106 | |
| | | 1.00 | 1.80 | 104 | |
| River water | 16 | 0 | 0.46 | - | 7.44 |
| | | 0.50 | 0.96 | 98 | |
| | | 1.00 | 1.44 | 97 | |