

Measurement of Emotional Response by Similarity in Patterns of Galvanic Skin Reflex

Yoshitake YAMAMOTO*, Hiromi ISSHIKI**, Hisao OKA*
and Tatsuma YAMAMOTO*

(Received September 25, 1989)

Synopsis

There is no doubt that many people feel the peace of mind or the pleasures of senses in appreciating music. But the estimation of the effect is very difficult and the objective estimation can be hardly done. This study proposed the objective estimating method of human emotion utilizing galvanic skin reflex (GSR) which reflects a human psychological activity. In this method, not by individual response, but by the series of response and pattern of appearance of GSR, the emotional response under appreciating music was investigated. In the case of appreciation of the same classic music to several subjects, the individual GSR responses are random and remarkable characteristic could not be find on the results. However, on the patterns of appearance of GSR, the patterns obtaining from the same generation are much similar each other and the patterns obtaining from different generation are less similar. It was cleared that the same music gave different effect on different generations.

1. INTRODUCTION

It is well known that GSR is an effective index which shows us states of human mental activity. It has been applied in a lie detector

* Department of Electrical and Electronic Engineering

** Maizuru College of Technology, Maizuru

up to the present. Recently GSR is being applied as an image training for sports and so on [1]. Music is playing a very important roles to people's life from ancient times to the present. But the effects which musics give people change according to a lot of factors, and it is difficult to catch them objectively. GSR is a transient short time phenomena of electrical activity on a living body, and gives influences to development of modern psychophysiology. We can measure easily human mental reflex, non-restraintly and non-invasively using GSR. It is an objective index which shows us circumstances of human mental activity. This report examines a method which we quantitatively evaluated similarity and degree of the effect, which music gives human, using the appearance pattern of GSR in order to know transition of human mental activity under appreciating the music.

2. MEASUREMENT AND EVALUATING METHOD OF GSR

2.1 Skin Impedance

GSR, which is a transient short time variation of electrical activity on a living body going with human emotion, contains Skin Potential Reflex, Skin Resistance Reflex and so on [2]-[6]. We adopted the impedance method which substitutes an alternating current for a direct current flow through the skin because not only it is easy for us to measure and the measured value is stable but the variation is little while measuring GSR for hours. Usually the skin impedance is expressed by the parallel equivalent circuit of R_2 , C_p , r_p [7]-[8]. R_2 is the resistance that has no relation with a frequency. r_p and c_p are the polarization impedance depending on dielectric polarization and are expressed by the following equations:

$$\left. \begin{aligned} c_p &= \omega^{\beta-1} c_o \\ r_p &= r_o / \omega^{\beta} \end{aligned} \right\} \quad (1)$$

c_o and r_o are respectively the values of c_p and r_p at the angular frequency $\omega = 1$. β is a parameter which expresses the deviation from the Debye system. This equivalent circuit can be also expressed by the equivalent series resistance R_s and reactance X_s . Then the skin impedance can be expressed by the following equations:

$$Z_1 = R_s - jX_s \quad (2)$$

where

$$R_s = \frac{1/R_2 + \omega^\beta / r_o}{(1/R_2 + \omega^\beta / r_o)^2 + (\omega^\beta C_o)^2} \tag{3}$$

$$X_s = \frac{\omega^\beta C_o}{(1/R_2 + \omega^\beta / r_o)^2 + (\omega^\beta C_o)^2} \tag{4}$$

The lower the frequency is, the more largely the impedance variation can be taken out. However, in cases where the frequency is extremely low, it is difficult to measure GSR accurately because of the polarization of the electrode by direct current flow, physiological effects on the skin by direct current flow and variations of the electric property due to current injection. Taking account of these problems, it was decided that the measuring frequency was 20Hz.

2.2 Measuring System of Skin Impedance

The block diagram of the measuring instrument is shown in Fig.1. Its operation depends on the phase sensitive detector which is constituted of a multiplier on a constant current [9]. If the voltage and current values at various points are defined as shown in Fig.2. First, the output voltage from the oscillator is converted into the current of the same phase angle and the constant amplitude and this current flows through the skin. The skin impedance is taken out as the potential drop V_{z1} caused by current flow through the skin and its

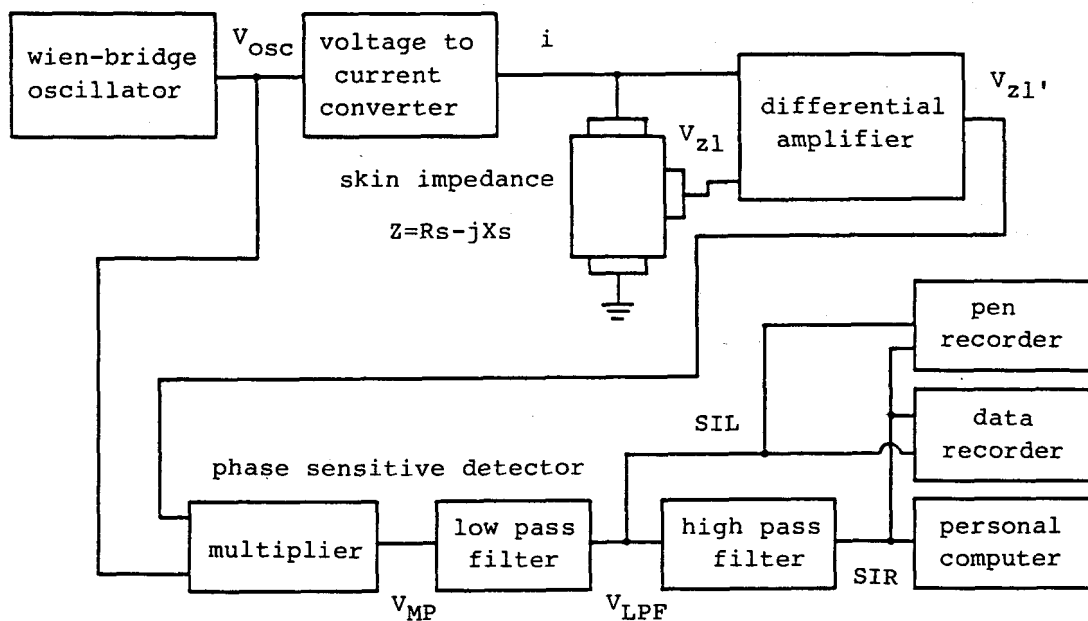

Fig.1 Block diagram of GSR measurement system.

drop is amplified by a differential amplifier. The V_{z1}' is compared in phase with the oscillator signal, V_{OSC} , and the output signal is obtained. By subtracting the term whose frequency component is twice that of the oscillator signal using a LPF (low pass filter), the direct voltage is obtained and becomes the voltage (SIL) which is proportion to the equivalent series resistance component, R_s , of the skin impedance, Z , at the LPF output. In addition by passing this SIL signal through a HPF (high pass filter) whose time constant is 3 seconds, we can take out the variation component (SIR) of the skin impedance as a waveform.

It is the merit that this system can reproduce data of the wave form by using a cassette data recorder and floppy disks in order to make good use of the signal on a living body. The wave forms recorded in the data recorder are SIL and SIR. The output signals (SIL and SIR) from the skin impedance measuring device are recorded in a pen recorder and a data recorder. At the same time the SIR waveform is transferred to a personal computer via an analogue-to-digital converter. These data are processed by the GSR detection software and are finally, saved on a floppy disk in the form of compressing the real data. These records, as the occasion demands, can be taken in and out, and as a result, we can compress the time of processing data remarkably.

2.3 Detecting and Evaluating Method of GSR

The output signal (SIR) from the measuring device of the skin impedance is converted into the digital data of 12 bit by the analogue-to-digital converter and transferred to a personal computer. GSR appearances are detected and evaluated with the software, and in order the data compressed at the real time are put in the memory, and

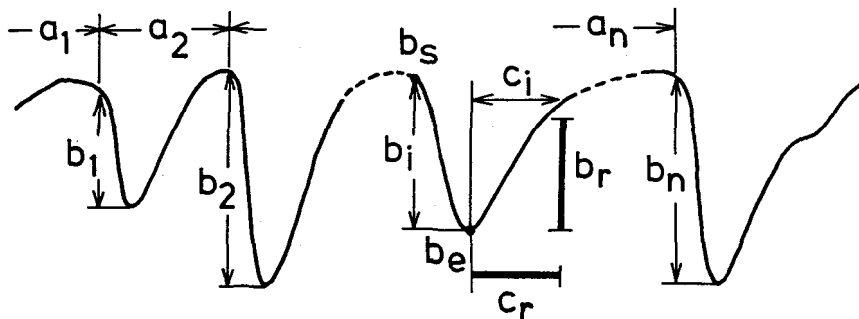

Fig.2 Wave form of SIR and its parameters.

recorded in floppy disks after the experiment. Detecting and evaluating methods are as follows.

The wave form of SIR in appearing GSR is shown in Fig.2. Three elements (the appearing number n , the appearing interval a_n , and the amplitude b_n) are caught as the data. It is decided that the appearing GSR is judged paying attention to the gradient of the SIR wave. The detecting and evaluating process of appearing GSR are as follows. When the gradient of the SIR wave which was read into the computer changes from zero or positive to negative, the level b_s is recorded. The difference of the level from that point b_s to the point b_e in which the gradient again changes to positive is expressed by b_i . This difference is checked whether it is larger than the fixed amplitude b_r which is the threshold of judging the appearance of GSR, and if the condition $b_i > b_r$ is satisfied, it is set that $cf = 1$. And the wave form of SIR tends to return from the level b_e to zero. When it satisfies the above-mentioned condition and the interval c_i is over the fixed interval c_r which is the other threshold, the computer judges that GSR appears. The thresholds b_r and c_r were set at 780 and 1 sec, respectively. By the above mentioned detecting algorithm, the GSR appearance is detected and at the same time the real data can be compressed remarkably by transforming to the GSR amplitude and the

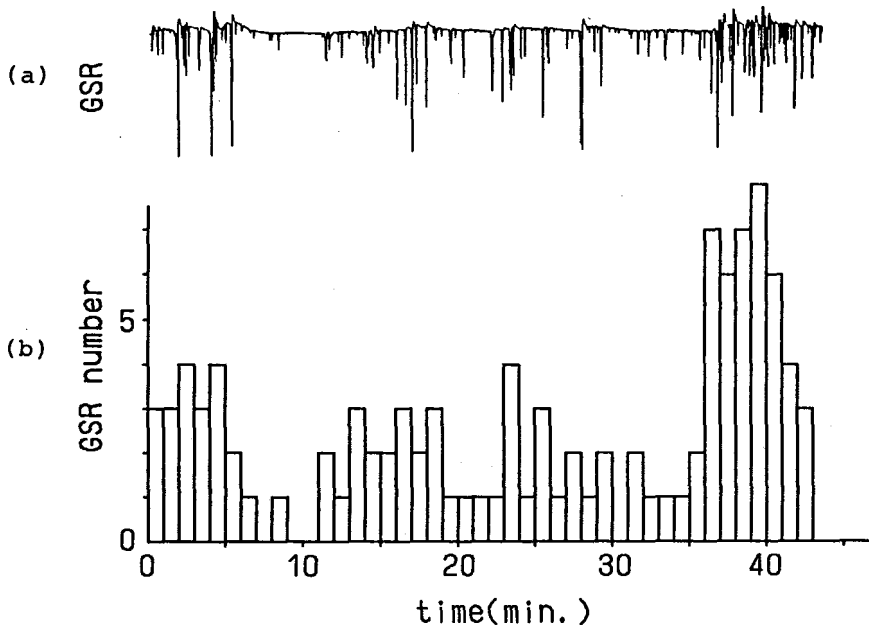

Fig.3 (a) SIR wave forms and (b) histogram of appearance number.

interval parameter.

As the above-mentioned GSR reflects human mental activity. Fig.3 are examples of results of the experiment that subjects were practically given a mental load. Fig.3(a) is the wave forms of SIR, and (b) is the result processed the histogram of the appearance number of GSR frequency per minute.

3. HUMAN EMOTIONAL ESTIMATION BY SIMILARITY

It is clear that GSR appears in the loading state more frequently than in the quiet state, hence, it can be known that the act of mental arithmetic causes human emotional response.

But it is difficult to examine a lot of results synthetically, quantitatively and each other by using this histogram. We propose a method which the characteristics of the appearance pattern of GSR are evaluated by using the similarity and the human emotional transitions are estimated quantitatively.

The similarity used in this report is followed to a pattern matching method availed to pattern recognition. When two vectors of the wave form maked an object of this study are respectively F_i and G_i , the similarity of pattern is showed by a following equation[10].

$$\text{Sim} = \frac{\sum_{i=1}^n F_i G_i}{\sqrt{\sum_{i=1}^n F_i^2 \sum_{i=1}^n G_i^2}} \quad (5)$$

Its value is from -1 to 1. When F is agree with G, its value becomes 1. When F differs from G more, its value becomes smaller. F_i is the average wave form of several subjects, and G_i is the wave form of each subject. Here, we did not adopt the appearance number as it but the value normalized by the average of the appearance number of GSR in the wave form of each subject. When the appearance number is larger than the average of the appearance number of GSR, its value becomes positive. When the appearance number is smaller than the average of the appearance number of GSR, its value becomes negative.

4. RESULTS

We present results of an experiment in which five subjects were asked to listen to the clasical music (Symphony No.5, Beethoven) in

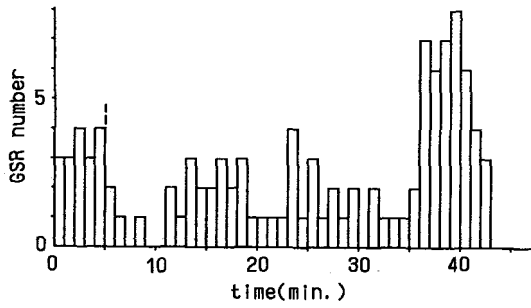

(a) Subject A (male, 24 years)
Sim=0.73

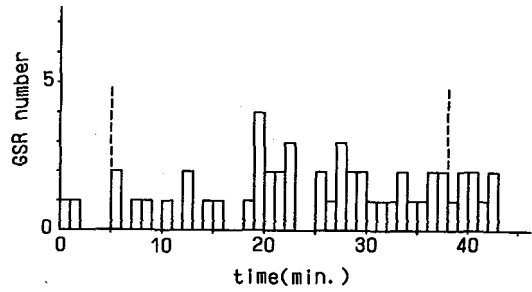

(b) Subject B (male, 22 years)
Sim=0.68

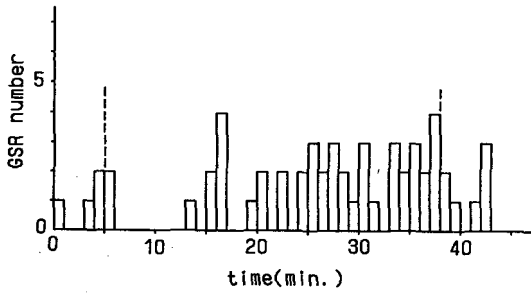

(c) Subject C (male, 22 years)
Sim=0.70

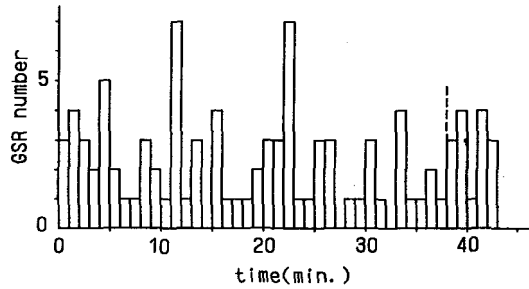

(d) Subject D (male, 24 years)
Sim=0.61

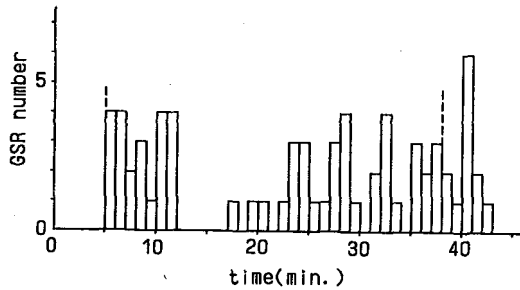

(e) Subject E (male, 45 years)
Sim=0.46

Fig.4 GSR appearance whilst appreciating music (Symphony No.5, Beethoven).

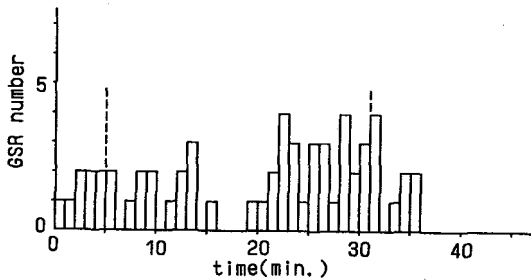

(a) Subject A (male, 22 years)
Sim=0.47

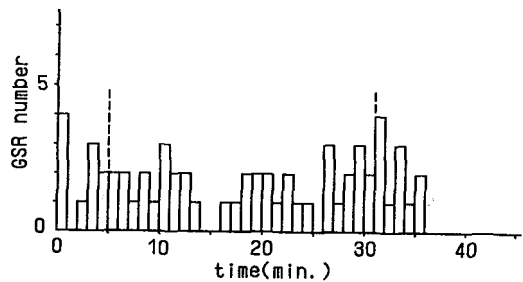

(b) Subject B (male, 24 years)
Sim=0.47

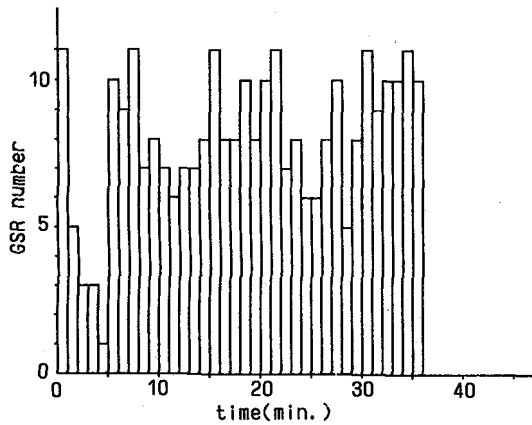

(c) Subject C (male, 22 years)
Sim=0.38

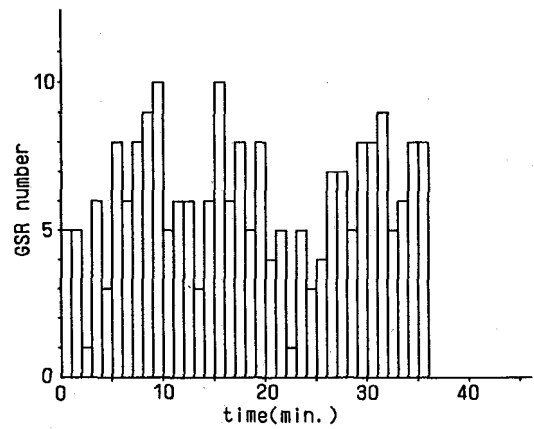

(d) Subject D (male, 24 years)
Sim=0.37

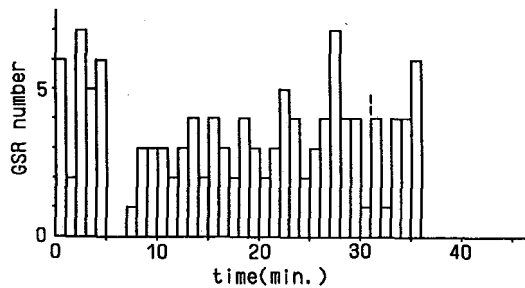

(e) Subject E (female, 12 years)
Sim=0.36

Fig.5 GSR appearance whilst appreciating music (Symphony, No.40, Morzart).

Fig.4. The sex and the age of each subject are also shown in the same figure. Since similarities of four subjects (except subject E) are high and close to each other, we can think that the responses of four subjects to this music are similar. The similarity of subject E is away form the others. This means that the response of subject E differs from the others. Fig.5 is the result in another classical music (Symphony No.40, Mozart). All similarities are low. The similarities between five subjects are not found out. We consider that the response to this music is smaller or more complicated than the former music.

5. CONCLUSIONS

High similarity shows the intensity of influence, which a media gives to human, or the equality of individuality and the sense of values of person, It is difficult to recognize either, however using the similarity, we could evaluate the time course of human emotion under appreciating music and estimate effects which the music gave to human. We can expect that the similarity enables the estimation of human emotional variation and composition of a song suitable for a purpose. It is necessary to measure for many subjects and collect the data in order to make this method meaningful criteria for estimating emotional responses.

REFERENCES

- [1] A. Katsube: Image in Sports and GSR Phenomenon, *J. of Clinical Sports Medicine*, 5, 11(1988), pp.1215-1216
- [2] Y. Niimi and Y. Shirafuji: Galvanic Skin Reflex (in Japanese), *Ishiyaku-shuppansha*(1969), pp.9-10
- [3] J.G. Montagu and E.M. Cole: Mechanism and measurement of the galvanic skin response, *Psychological Bulletin* 65, 5(1966), pp.261-279
- [4] R. Edelberg: Electrical Properties of the Skin. in: *Methods in Psychophysiology*, Ed: C.C.Brown, Williams and Wilkins Company, Baltimore(1967), pp.1-53
- [5] Y. Yamamoto and T. Yamamoto: The Characteristics of Galvanic Skin Reflex in Low Awaked Level and their Application to Measurement of Sleep, *Trans. Inst. Electrical Engineers of Japan*, 109-C, 7(1988), pp.457-463
- [6] Y. Yamamoto, H. Isshiki, and T. Yamamoto: Study using fuzzy model of emotional response to static and active music by Galvanic skin reflex, 1st Intern. Conf. Music Perception and Cognition, HEL-9(1989)
- [7] T. Yamamoto and Y. Yamamoto: Dielectric constant and resistivity of epidermal stratum corneum, *Med. & Biol. Eng.*, 14, 5(1976), pp.494-500
- [8] T. Yamamoto and Y. Yamamoto: Analysis for the Change of Skin Impedance, *Med. & Biol. Eng. & Comput.*, 15, 3(1977), pp.219-227
- [9] Y. Yamamoto and T. Yamamoto: Dynamic System for the Measurement of Electrical Skin Impedance", *Med. & Biol. Eng. & Comput.*, 17, 1(1979), pp.135-137

- [10] The Institute of Electronics and Communication Engineers of Japan:
"Handbook for Electronics and Communication Engineers", 32.
Pattern information processing(1979), 1761