

## *Discharge Coefficient of a Sluice Gate Placed at Sudden Expansion of Open Channel*

Hiroshi NAGŌ\* and Syuzō FURUKAWA\*

(Received November 5, 1979)

### Synopsis

In this paper the discharge coefficient of a sluice gate placed at the sudden expansion of an open channel is investigated theoretically and experimentally. Lateral and vertical expansions are treated in the study. The coefficients obtained for channels with sudden expansion are compared with those for the straight channel.

For free efflux, experimental results show that the coefficients for expanded channels are always larger than those for a straight one, and that the coefficient for a channel to be fully expanded to both lateral and vertical directions takes about 1.2 times larger value than that for a straight one.

For submerged efflux, the coefficient is obtained theoretically by using the efflux model shown in this study. The theoretical results explain the experimental ones fairly well. The coefficient for lateral expansion is always smaller than that for a straight channel. The minimum downstream water depth required to submerged efflux for the expanded channels becomes smaller than that for a straight channel.

### 1. Introduction

There are many basic studies on the efflux from a sluice gate in the open channel[1]. Almost all of them are about the gate placed in the straight and horizontal channel. However, the channel geometry in prac-

---

\* Department of Civil Engineering

tice are very manifold. Then, in this paper as a first step of studying on the characteristics of efflux mechanism with the channel geometry, the discharge coefficients of the gate placed at channel expansions shown in Fig.1.1 are investigated.

For the experiments the main channel (shown in Fig.1.2) that the cross section is 0.3 m width X 0.4 m depth for upstream and 1.0 m X 0.7 m for downstream of the gate is used.

The discharge coefficient  $C$  in this paper is given by the following equation under both free and submerged discharge conditions.

$$C = Q / ( B_1 a \sqrt{2gh_1} ) \tag{1.1}$$

where,  $Q$  : discharge,  $B_1$  : channel width upstream of the gate,  $a$  : gate opening,  $h_1$  : upstream water depth, and  $g$  : acceleration due to gravity.

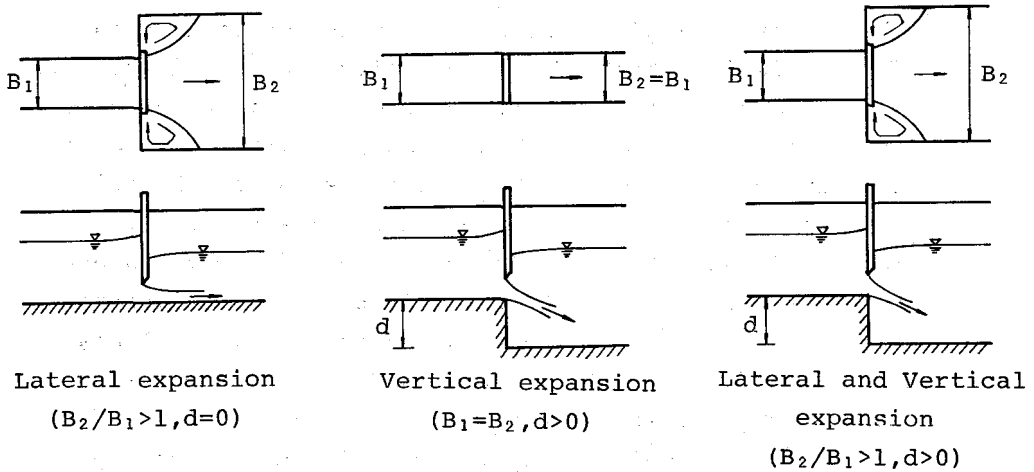

Fig.1.1 Several types of expansion

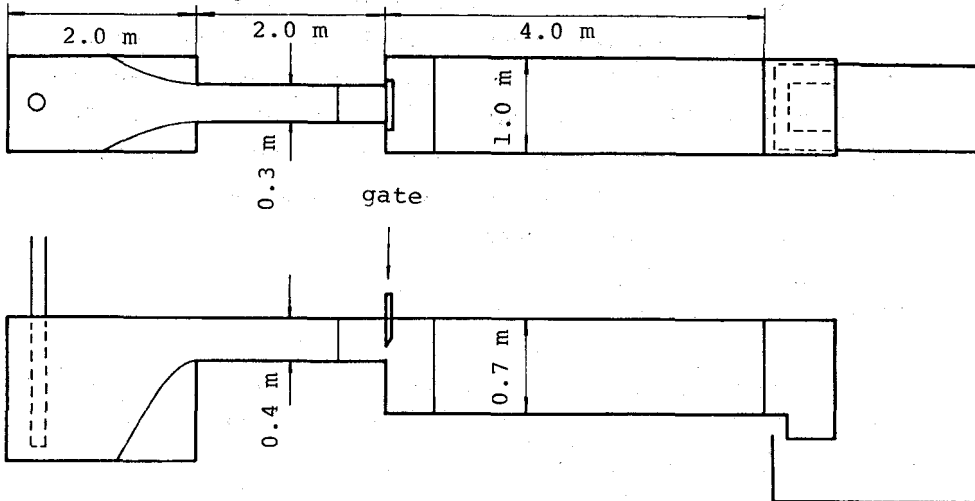

Fig.1.2 Experimental flume

2. Discharge Coefficient under Free Efflux Conditions

2.1 Influence of Lateral Expansion under  $d=0$

In order to clarify the influence of the lateral expansion on the coefficient, horizontal channels ( $d=0$ ) were used for the experiment. Several expansion ratios  $B_2/B_1$  between 1 and 3.3 are adopted. The results are shown in Fig. 2.1, Fig. 2.2 and Fig. 2.3.

The dotted line in these figures is Henry's experimental curve for a straight channel [2]. Fig. 2.4 shows the relation between  $B_2/B_1$  and  $C/C_0$ , in which  $C_0$  is the discharge coefficient for the channel with  $B_2/B_1=1$  and  $d=0$ . These figures show that;

- (1) For constant opening ratio  $a/h_1$ , the coefficient  $C$  increases rapidly with channel expansion and approaches to the constant value.
- (2) For constant expansion ratio  $B_2/B_1$ , the coefficient increases with  $a/B_1$ .

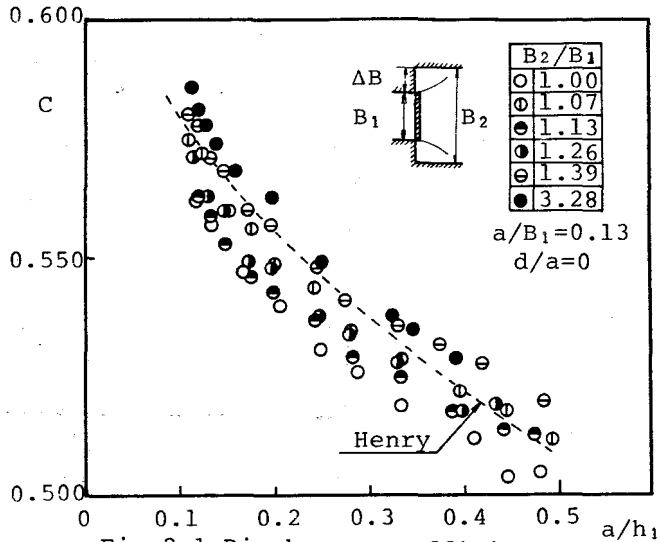

Fig.2.1 Discharge coefficient (lateral expansion)

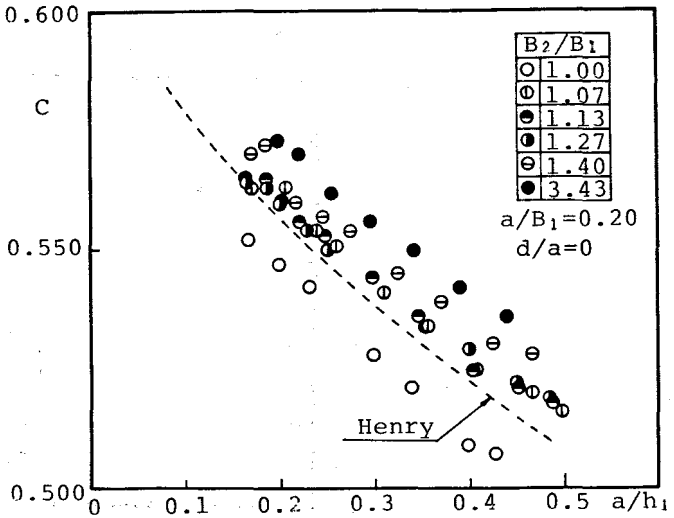

Fig.2.2 Discharge coefficient (lateral expansion)

2.2 Influence of Vertical Expansion under  $B_2/B_1=1$

In order to clarify the influence of vertical expansion, straight channels ( $B_2=B_1$ ) were used for the experiment. The height of step down was varied from 0.8 to 30 cm. The results are shown in Fig. 2.5. This figure shows that the influence of vertical expansion is more notable than that of lateral expansion. Fig. 2.6 shows that the relation between

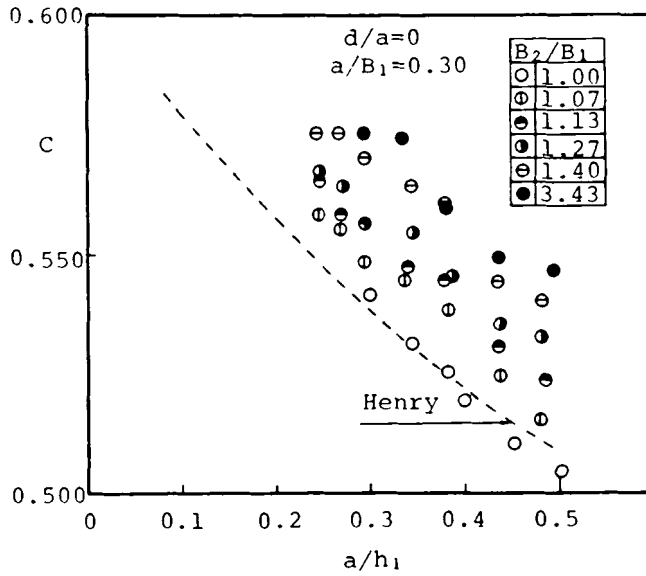

Fig.2.3 Discharge coefficient (lateral expansion)

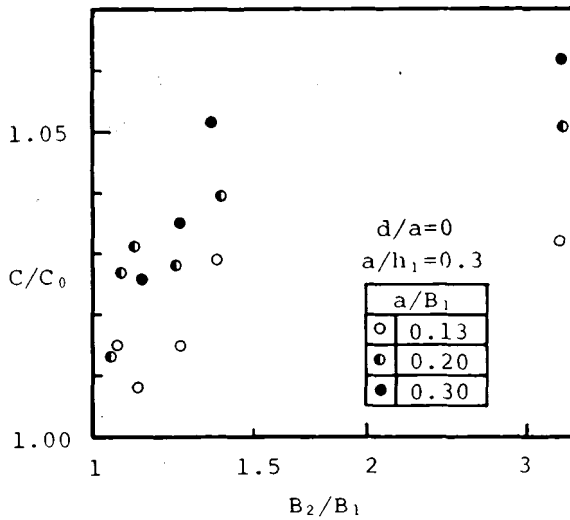

Fig.2.4 Discharge coefficient (lateral expansion)

$C/C_0$  and  $d/a$  is similar to that between  $C/C_0$  and  $B_2/B_1$ . That is,  $C/C_0$  increases with  $d/a$  rapidly in the region where  $d/a$  is very small.

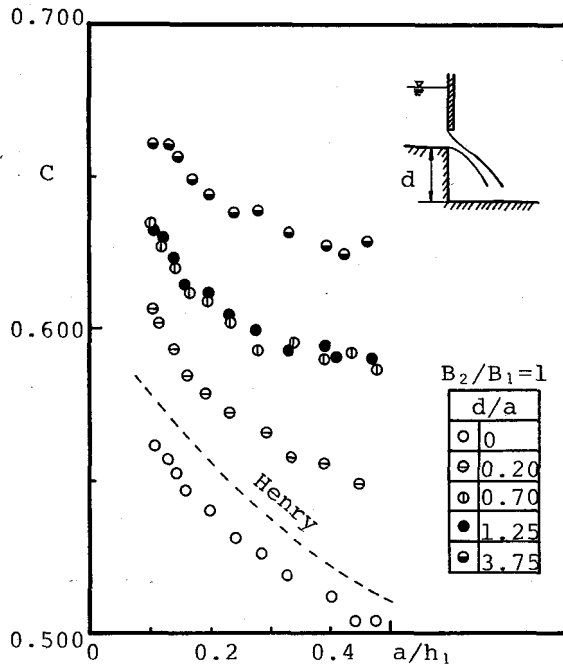

Fig.2.5 Discharge coefficient (vertical expansion)

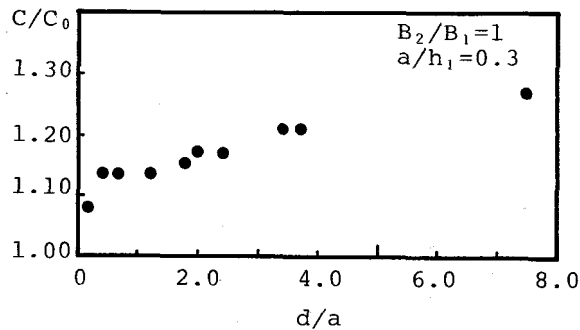

Fig.2.6 Discharge coefficient (vertical expansion)

### 2.3 Discharge Coefficient under Both Expansions

Fig.2.7 shows the influence of vertical expansion under the conditions that the lateral expansion exist or not. Fig.2.8 shows the coefficients for two limited conditions, that is, one is for horizontal and straight channel, and the other is for fully expanded channel both to lateral and to vertical directions. Fig.2.8 shows that the coefficient for fully expanded channel is about 1.2 times larger than that for the channel without expansion.

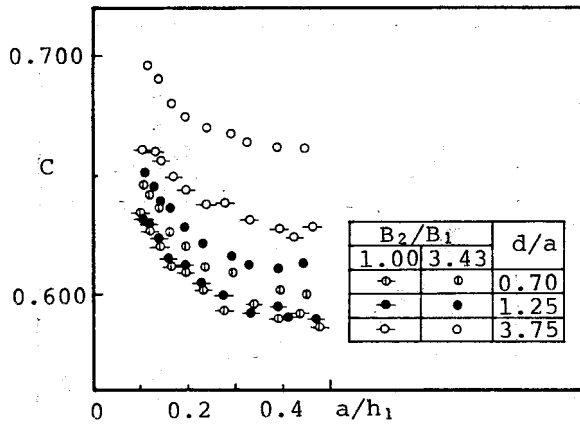

Fig.2.7 Discharge coefficient  
(vertical expansion under large lateral expansion)

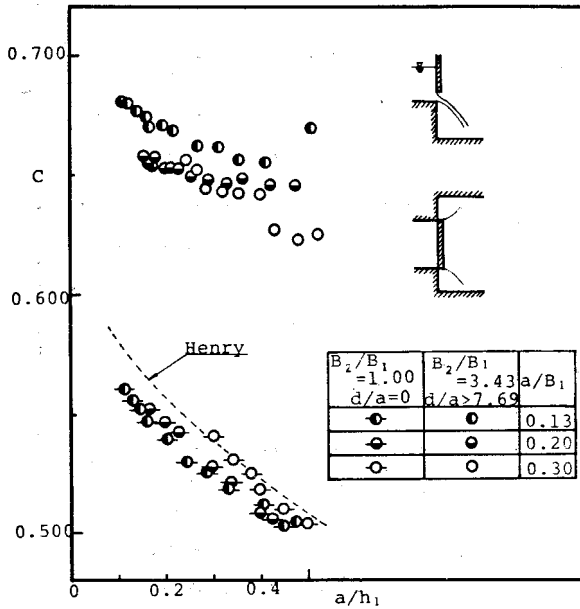

Fig.2.8 Discharge coefficient  
(fully expanded to both directions)

### 3. Discharge Coefficient under Submerged Efflux Conditions

#### 3.1 Theoretical Investigation

The submerged efflux from a gate placed at the channel expansion

modeled as shown in Fig.3.1. By applying the energy conservation's law between the section I and II, and the momentum one between the section II and III, the theoretical discharge coefficient  $C_T$  is obtained as follows.

$$C_T = C_C \sqrt{\{(d+h_1)/h_1 - h_2/h_1\} / \{1 - (C_C a/h_1)^2\}} \quad , \quad (3.1)$$

where,

$$h_2/h_1 = 1/2 [D \pm \sqrt{D^2 + 4\{(h_3/h_1)^2 - D(h_1+d)/h_1\}}] \quad ,$$

$$D = [4A / \{L(A^2 - 1)\}] \{Ah_1 / (Lh_3) - \cos\alpha\} , A = C_C a/h_1 , L = B_2/B_1 . \quad (3.2)$$

As the assumed contraction coefficient Mueller's theoretical value is used for the case that the vertical expansion is not exist, and v.Mises' shown in table 3.1 is used for the case with vertical expansion [3],[4].

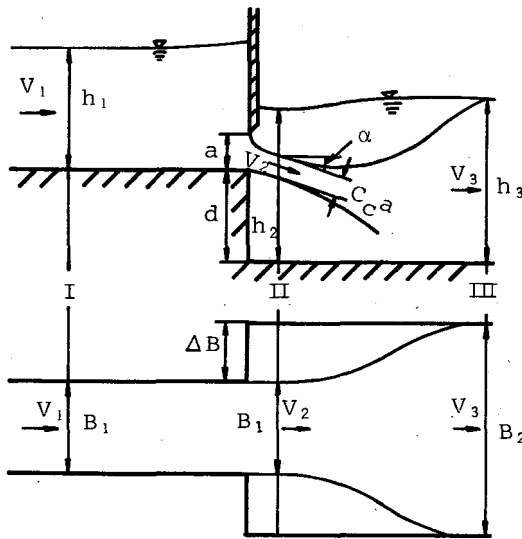

Table 3.1 Contraction coefficient by v.Mises

$a/h_1=0.0$	$C_C=0.673$	$\alpha=21^\circ$
0.1	0.676	20° 55'
0.2	0.680	20° 35'
0.3	0.686	20° 5'
0.4	0.693	19° 40'
0.5	0.702	19°
0.6	0.720	18°
0.7	0.740	16° 30'
0.8	0.782	14° 20'
0.9	0.842	11° 5'

Fig. 3.1 Schematic diagram of submerged efflux

3.1.1 Influence of Lateral Expansion (d=a)

Under the condition d=0, the coefficient  $C_T$  is calculated by using eq.(3.1) and eq.(3.2), and similarly  $C_{T_0}$  for the case without expansion

is obtained by providing  $d=0$  and  $B_1=B_2$ . The results are shown in Fig.3.2 and Fig.3.3. In each figure as  $B_2/B_1$  increases,  $C_T/C_{T_0}$  first decreases suddenly from the value 1.0 and approaches gradually to the constant value. It is also evident that  $C_T/C_{T_0}$  decreases with  $a/h_1$  under the condition  $(h_1-h_3)/a=\text{constant}$ , and with  $(h_1-h_3)/a$  under  $a/h_1=\text{constant}$ .  $C_T$  for  $B_2/B_1=\infty$ , is shown in Fig.3.4 and Fig.3.5. The boundary between a free discharge and a submerged one shown in these figures is calculated by providing  $h_2=C_c a$ . These figures show that as  $a/h_1$  increases, the change of  $C_T$  to the increment of  $(h_1-h_3)/a$  becomes large. In Fig. 3.6 the boundary is also shown in the relation between  $h_3/h_1$  and  $a/h_1$ . This figure shows that as  $B_2/B_1$  increases, the minimum downstream water depth required to submerged efflux becomes small under  $a/h_1=\text{constant}$ .

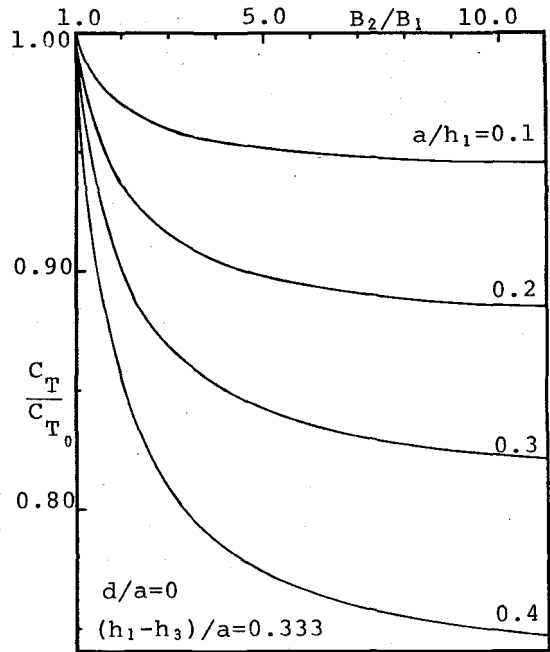

Fig.3.2 Discharge coefficient (lateral expansion)

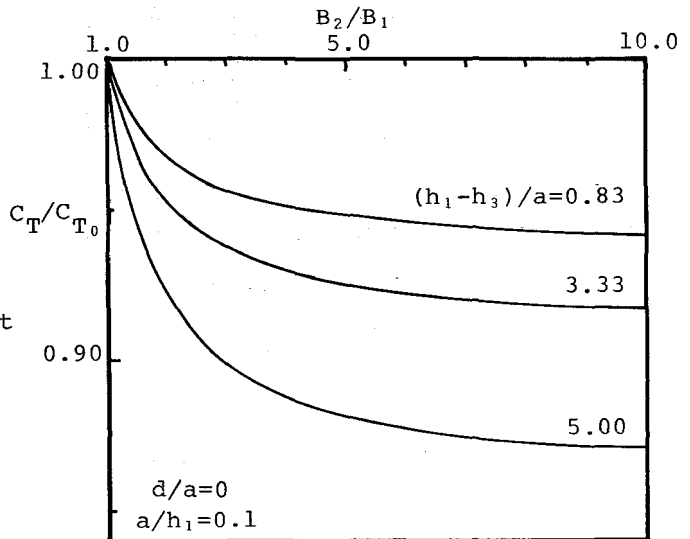

Fig.3.3 Discharge coefficient (lateral expansion)



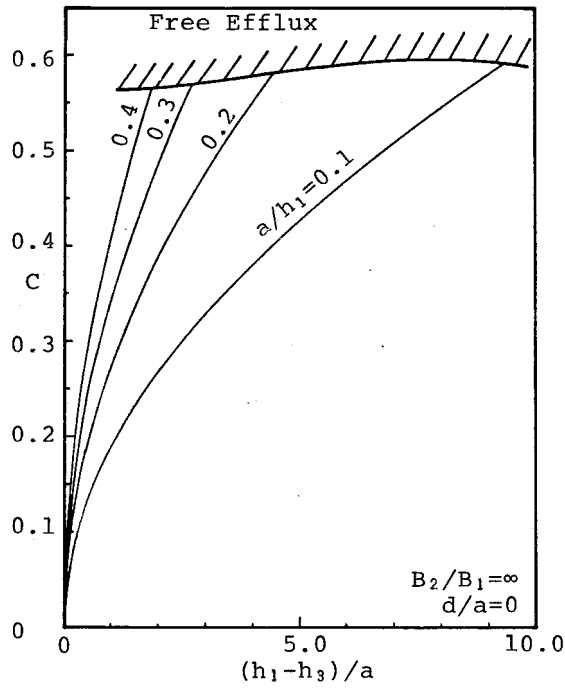

Fig.3.4 Discharge coefficient (lateral expansion)

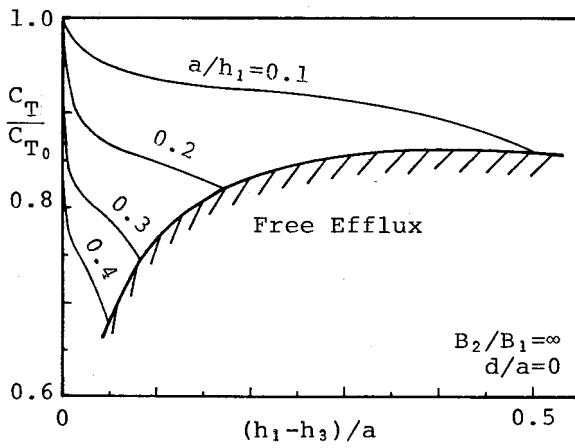

Fig.3.5 Discharge coefficient (lateral expansion)

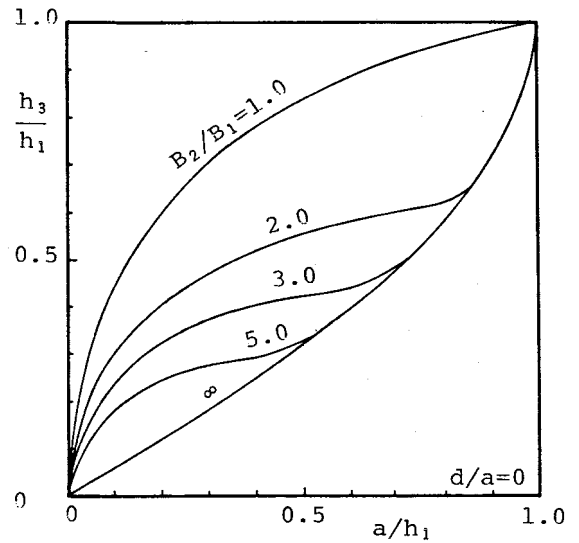

Fig.3.6 Boundary between free and submerged (lateral expansion)

3.1.2 Influence of Vertical Expansion ( $B_1=B_2$ )

Under the condition  $B_1=B_2$ ,  $C_T$  is similarly calculated by using eq. (3.1) and eq. (3.2). The relation between  $C_T/C_{T_0}$  and  $d/a$  are shown in Fig.3.7 and Fig.3.8. In each figure, though the decreasing tendency of  $C_T/C_{T_0}$  with  $d/a$  is similar to one with  $B_2/B_1$  mentioned above, it happens that  $C_T$  becomes larger than  $C_{T_0}$  for small  $d/a$ . The boundaries calculated as shown in Fig.3.9. This figure shows that as the height of vertical expansion increases, the minimum downstream water depth required to submerged efflux becomes small in the same manner as that for lateral expansion.

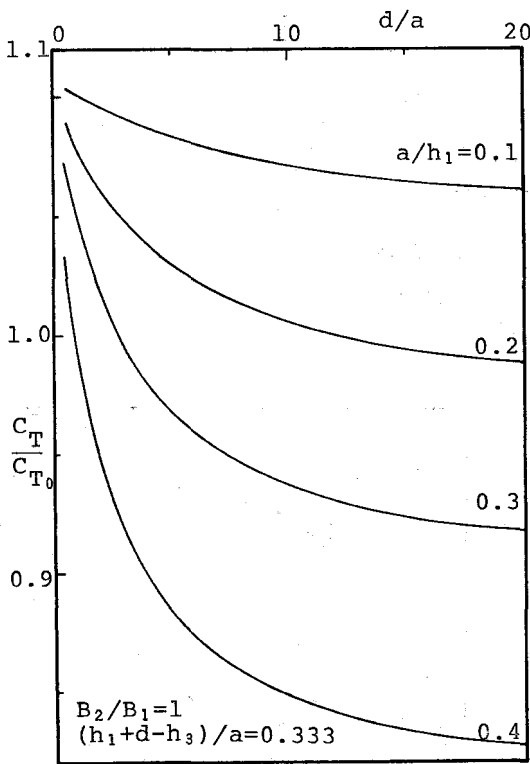

Fig.3.7 Discharge coefficient (vertical expansion)

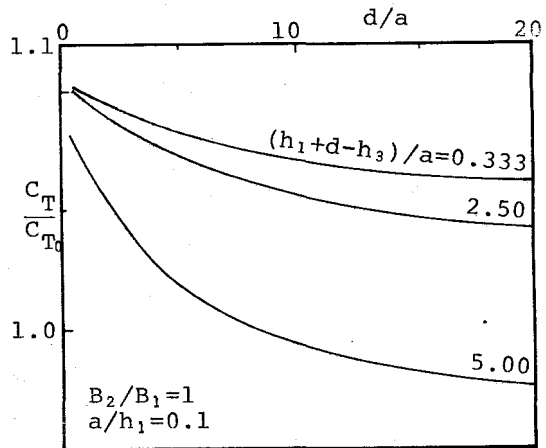

Fig.3.8 Discharge coefficient (vertical expansion)

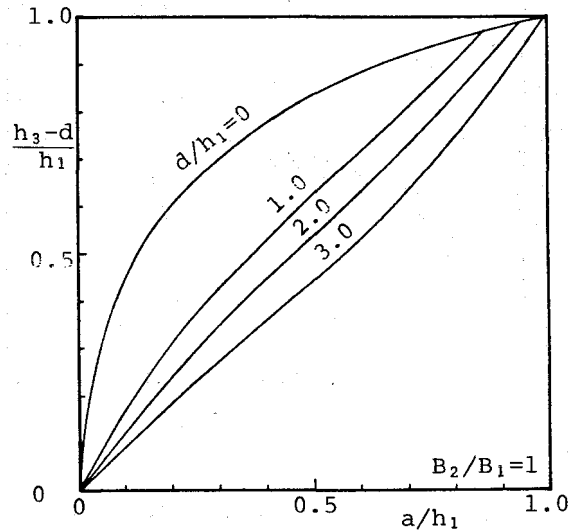

Fig.3.9 Boundary between free and submerged (vertical expansion)

3.2 Experimental Verifications

In the experiment the gate opening  $a$  was fixed at 4.0 cm. This value gives the model scale to be able to nearly neglect the scale effects. Experimental results are shown in Fig.3.10, Fig.3.11 and Fig.3.12. In each figure the experimental values  $C_E$  are compared with the theoretical ones  $C_T$ . These figures show that experimental values are always several percent smaller than theoretical ones, even if the values of  $B_2/B_1$  and  $d/a$  varies. But it seems that the method of analysis in this paper is fairly well applicable to estimate the discharge coefficients of the sluice gate placed at the channel expansions.

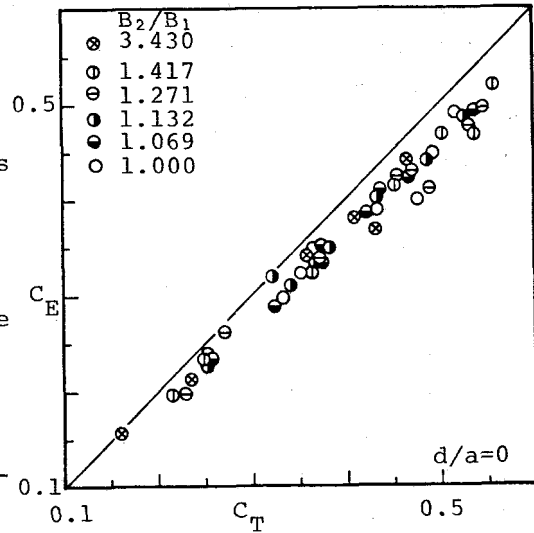

Fig.3.10 Discharge coefficient (lateral expansion)

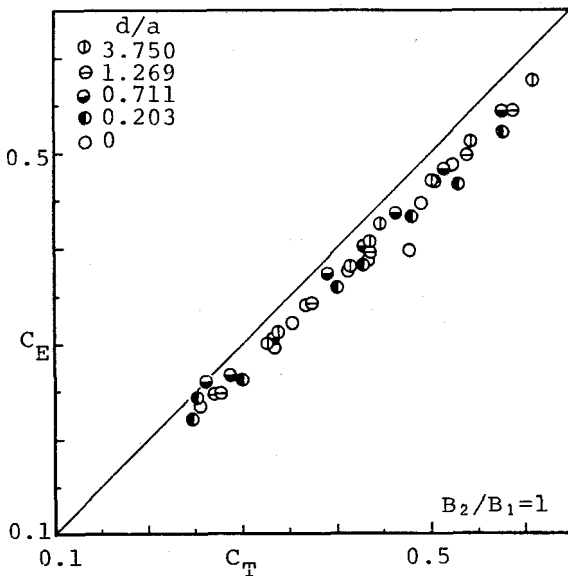

Fig.3.11 Discharge coefficient (vertical expansion)

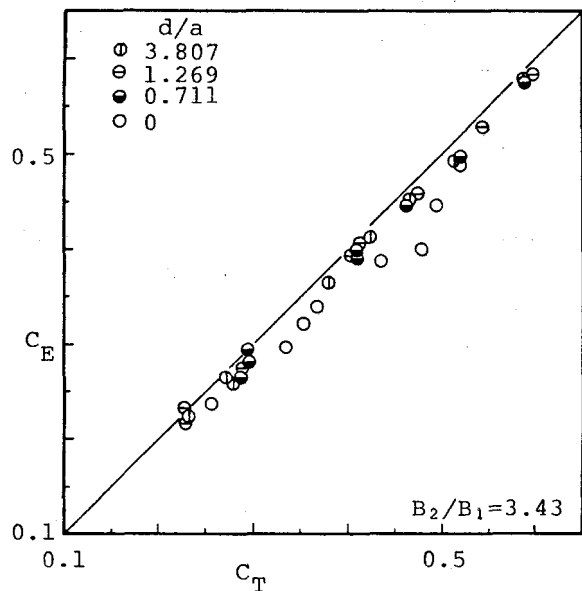

Fig.3.12 Discharge coefficient (vertical expansion under large lateral expansion)

#### 4. Conclusions

In this study the discharge coefficients of a sluice gate placed at channel expansions have been investigated experimentally and theoretically comparing with those of a horizontal and straight channel. The main results obtained in this study as follows.

(1) Under free discharge conditions, it is clarified experimentally that the influence of vertical expansion is more dominant than that of lateral one, and that as the degree of expansions increase, the coefficients first become large suddenly and then approach gradually to the constant values. The coefficient for the channel to be fully expanded to both directions is about 1.2 times larger than that for a horizontal and straight channel.

(2) Under submerged discharge conditions, it is verified by experiments that the theoretical analysis to be developed in this study is applicable to estimate the discharge coefficient. The coefficient for lateral expansion is always smaller than that for a straight channel. The minimum downstream water depth required to submerged efflux for the expanded channels becomes smaller than that for a horizontal and straight channel.

The writers would like to thank Sadahiro Nanba and Makoto Nanba for their help in the construction of the flume and through the experiments.

#### References

- [1] H.Nago : Doctoral Thesis, Kyoto Univ. Tech. 592 (1973)
- [2] H.R.Henry : Trans. ASCE, 115 (1950)
- [3] H.Mueller : Wasser und Wasserwirtschaft, 24 (1935)
- [4] R.v.Mises : V.D.I. (1917)