

Acta Medica Okayama

Volume 36, Issue 5

1982

Article 7

OCTOBER 1982

Direct withdrawal of zones during preparative capillary type isotachopheresis.

Teruo Yamada* Alan Talbot† Yoshio Iijima‡
Yoshitaro Itano** Futami Kosaka††

*Okayama University,

†Okayama University,

‡Okayama University,

**Okayama University,

††Okayama University,

Direct withdrawal of zones during preparative capillary type isotachopheresis.*

Teruo Yamada, Alan Talbot, Yoshio Iijima, Yoshitaro Itano, and Futami Kosaka

Abstract

This study used a Shimadzu IP-1B capillary type isotachopheretic apparatus with a potential gradient detector. An ipp-1 withdrawal cell was fitted to this and a technique for withdrawing individual components directly through this port was developed using a microsyringe. The recovery rate was up to 45% for individual target components. When 100% withdrawal of the target component was attempted by withdrawing a volume four times the calculated volume (so that the zones both before and after the target component were also included), the best recovery rate was only 78%. In all cases, the results varied less than 3%. The limit for analysis of individual components of a 0.01 M solution was around 3 microliters. If this volume was exceeded, the ion quantity was too large for the volume of the microcapillary tube and mixed zones formed such that complete separation and analysis of individual components became impossible.

KEYWORDS: isotachopheresis, potential gradient detector ion mobility, ionic separation, withdrawal cell

*PMID: 7180573 [PubMed - indexed for MEDLINE]

Copyright (C) OKAYAMA UNIVERSITY MEDICAL SCHOOL

DIRECT WITHDRAWAL OF ZONES DURING PREPARATIVE CAPILLARY TYPE ISOTACHOPHORESIS.

Teruo YAMADA, Alan TALBOT, Yoshio IIJIMA, Yoshitaro ITANO
and Futami KOSAKA

*Department of Anesthesiology, Okayama University Medical School,
Okayama 700, Japan*

Received April 21, 1982

Abstract. This study used a Shimadzu IP-1B capillary type isotachophoretic apparatus with a potential gradient detector. An ipp-1 withdrawal cell was fitted to this and a technique for withdrawing individual components directly through this port was developed using a microsyringe. The recovery rate was up to 45 % for individual target components. When 100 % withdrawal of the target component was attempted by withdrawing a volume four times the calculated volume (so that the zones both before and after the target component were also included), the best recovery rate was only 78 %. In all cases, the results varied less than 3 %. The limit for analysis of individual components of a 0.01M solution was around 3 μ l. If this volume was exceeded, the ion quantity was too large for the volume of the microcapillary tube and mixed zones formed such that complete separation and analysis of individual components became impossible.

Key words : isotachophoresis, potential gradient detector, ion mobility, ionic separation, withdrawal cell.

The identification and quantitation of individual substances by capillary type isotachophoretic analysis is based on the use of various detectors (ultraviolet photometric (1), potential gradient (2,3), thermometric (4), conductivity (5-7)) or on the use of combinations of these detectors, but the results still leave room for improvement. What has been needed is some method of direct withdrawal of each component from the system and its identification by other methods such as those based on enzyme reactions.

In 1976, Arlinger used a Tachophor (LKB) apparatus to collect individual components after separation, and used various methods (immunological, radioactivity and zymogram techniques) to characterize and identify the sample components (8). Later, in 1981, Kobayashi *et al.* (9) attached an ipp-1 withdrawal cell to a Shimadzu Isotachophoretic Analyzer model IP-1B and collected the zones after separation. These were identified with a Shimadzu Auto GC-M5 model 6020, making it possible to identify accurately separated components by withdrawal.

In the present study, an ipp-1 withdrawal cell incorporating a potential

gradient detector (PGD) was attached to a Shimadzu Isotachophoretic Analyzer model IP-1B and used to investigate the limits of volumes that can be withdrawn and still give pure components without mixed zones.

MATERIALS AND METHODS

Materials. The composition of the electrolyte solutions is shown in Table 1. The stan-

TABLE 1. MIGRATION CONDITION FOR CAPILLARY TYPE ISOTACHOPHORESIS (IP-1B MODEL)

Leading electrolyte	10 mM HCl- β -alanine buffer pH 3.3 containing 0.3% Triton X-100
Terminating electrolyte	10 mM caproic acid solution
Potential gradient attenuation	256 mV
Migration current	100 μ A
Migration tube	30 cm long teflon tube of 0.5 mm internal diameter
Chart speed	10 mm/min.

dard samples were sodium citrate, lithium lactate, and sodium succinate. These chemicals were obtained from the Wakō Pure Chemical Industries Co., Osaka, Japan. Sodium citrate, lithium lactate, and sodium succinate were each made up as 0.01 M solutions, then equal volumes of each of these were mixed. From this mixture, 9 μ l (that is, 3 μ l of each standard) was used as the sample for analysis by isotachopheresis.

Instruments. The isotachophoretic procedure was performed with a Shimadzu Isotachophoretic Analyzer model IP-1B. The migration capillary tube was a Teflon tube 30 cm long with an internal diameter (I.D.) of 0.5 mm. The special cell used for withdrawal was a Shimadzu ipp-1 model withdrawal cell incorporating a potential gradient detector (PGD). This cell and the arrangement of the apparatus for migration is shown in Fig. 1.

Principle of withdrawal. The 9 μ l sample is injected into the Isotachophoretic Analyzer and a migration current of 100 μ A applied. The ions migrate in isotachopheresis towards the opposite electrode with equal velocity in the steady state. The sequence in general is determined by the actual (effective) mobilities. As each component passes the PGD, a plateau representing its potential gradient is recorded. After the posterior boundary of the target component is detected by the PGD, migration continues on to pass the bend (as indicated by the component B⁻ in Fig. 2) in the migration tube.

The time taken to reach the bend is calculated from the dimensions of the migration tube and the speed of migration (and confirmed by preliminary experiments). At the time when the posterior boundary is calculated to have reached the bend (position of B⁻ component, Fig. 2), the migration current is turned off, the leading valve is opened, and the terminal valve is left closed. When this is completed, a microsyringe set so that the tip of the needle just protrudes through the septum of the withdrawal cell (Fig. 2) is inserted. The volume of the target component to be withdrawn is calculated from the migration speed of the component (as explained below) and is withdrawn directly with the microsyringe.

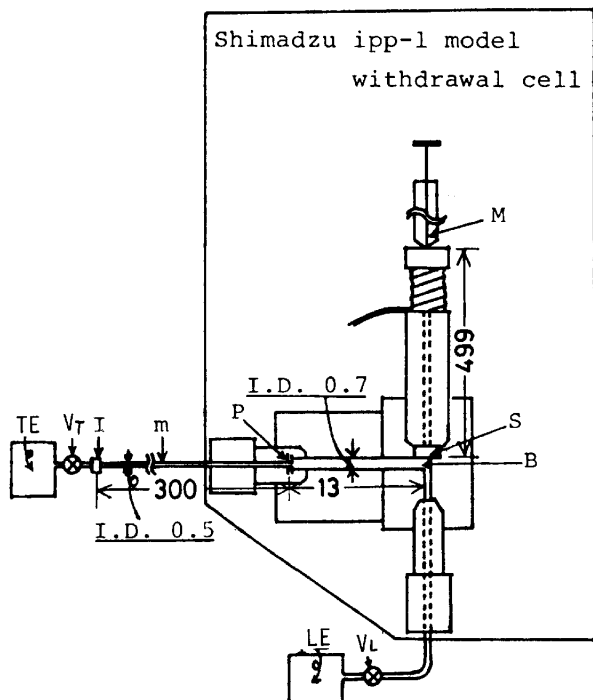

Fig. 1. The withdrawal cell (Shimadzu ipp-1 model) and attached potential gradient detector in place in the total migration system.

The sample is injected at the injection port (I) using a microsyringe, then the high voltage current is applied. The potential formed in the separated ion is detected by the PGD (P). The ions continue to migrate and samples can be taken with a microsyringe (M) at the place where the migration tube curves to form a corner (B).

Abbreviations: LE leading electrode, V_L leading valve, I injection port, m migration tube, P potential gradient detector, S septum, M microsyringe, V_T terminating valve, TE terminal electrode, B site where the migration tube bends to form a corner. Units: mm.

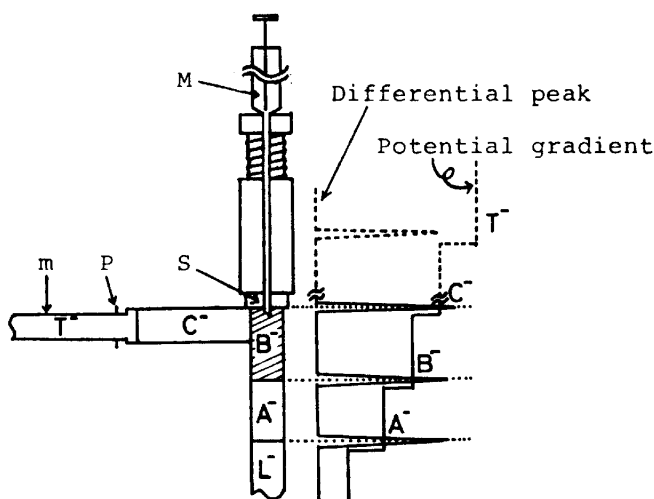

Fig. 2. A diagram of the principle of direct withdrawal of components via the withdrawal cell (ipp-1 model). This diagram is a modification of that given in the Shimadzu pamphlet CA 198-030.

Abbreviations: m, P, S, and M as for Fig. 1. L^- leading electrolyte ion; A^- , B^- , C^- : ions in the sample; T^- : terminating electrolyte.

If B^- is the component in question, the migration current is turned off after the following boundary of component B^- has turned the corner of the migration tube. Withdrawal is then performed with a microsyringe.

RESULTS

Timing of the withdrawal of a target component. The results for analysis of the 9 μl sample of the mixture of equal quantities of 0.01 M solutions of sodium citrate, lithium lactate, and sodium succinate under the conditions shown in Table 1 are shown on the left in Fig. 3 (A^- : citrate, B^- : lactate, C^- : succinate). The first component to migrate (A^-) needed 24 min to move through the distance of 30 cm; that is, the speed (S_1) at which this first component moved within the migration capillary tube in one minute was:

$$30 / 24 = 1.25 \text{ (cm/min)} \dots\dots(1)$$

Since the internal diameter of the tube was 0.05 cm, the internal volume per cm of tube is: $(0.05 / 2)^2 \times \pi \times 1 = 1.96 \text{ } (\mu\text{l})$. Therefore, the volume of component A^- that moved through the migration capillary tube in one minute was: $1.96 \times 1.25 = 2.44 \text{ } (\mu\text{l}) \dots\dots(2)$

The internal diameter of the tube from the PGD to the bend in the migration tube is 0.07 cm. The speed (S) of movement of ion through the tube is inversely proportional to the cross-sectional area (A) of the tube. Hence, the speed (S_2) of the migration in the wider portion of tube (diameter, 0.07 cm; area, A_2) can be calculated as follows: $S_2 = S_1 A_1 / A_2 = (1.25 \times \pi \times (0.05 / 2)^2) \div (\pi \times (0.07 / 2)^2) = 0.64 \text{ (cm/min)} \dots\dots(3)$

Since the distance from the PGD to the septum of the withdrawal cell is 1.3 cm (Fig. 1), the time for the target component to reach the bend in the septum after being detected by the PGD is: $1.3 / 0.64 = 2.04 \text{ (min)} \dots\dots(4)$

That is, 2.04 min from the differential peak registering the end of the zone of the target component, the migration current is cut, the leading valve opened, and withdrawal performed through the septum using a microsyringe.

Withdrawal of the target component. In Fig. 2, the target component B^- to be withdrawn had a zone length of 1.1 cm on the recording paper (the result of measuring the interval between the differential peaks before and after the area for component B^- with a scale). This indicates that component B^- took 1.1 min to move through the migration capillary tube. Its volume, therefore, (from equation (2)) was: $2.44 \times 1.1 = 2.68 \text{ } (\mu\text{l}) \dots\dots(5)$

Theoretically, withdrawing only 2.68 μl should be adequate; however, in actual practice, the best results for withdrawal of the target component only (confirmed by re-analyzing the material withdrawn by isotachopheresis) were obtained when very small amounts of the components before and after the target component were included in the withdrawal fraction. In the present experiments, the maximum withdrawal of only a single target component (B^-) was obtained when 1.5 times the calculated volume (equation (5)) was withdrawn into the microsyringe. The recovery rate was 45.3% (average of 5 independent experiments, the right of Fig. 3). When 100% withdrawal of the target component was attempted by withdrawing a volume four times the calculated volume (so that the zones both before and after the target component were also in-

cluded), the best recovery rate was only 78% (average of 5 independent experiments, Fig. 4).

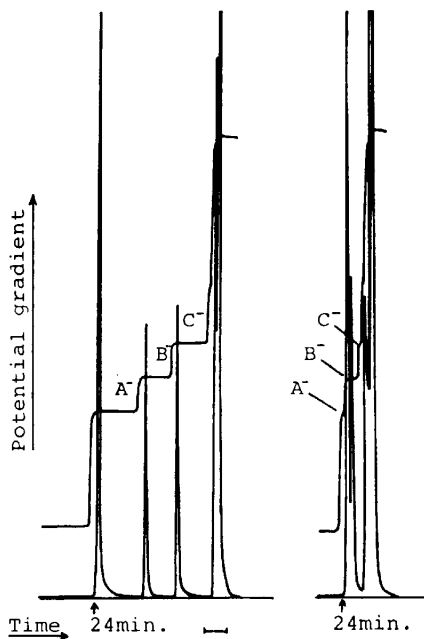

Fig. 3. Withdrawal of a target component. Equal volumes of 0.01 M solutions of citrate, lactate, and succinate were mixed and 9 μ l of the resultant solution analyzed under the conditions in Table 1. The result is on the left.

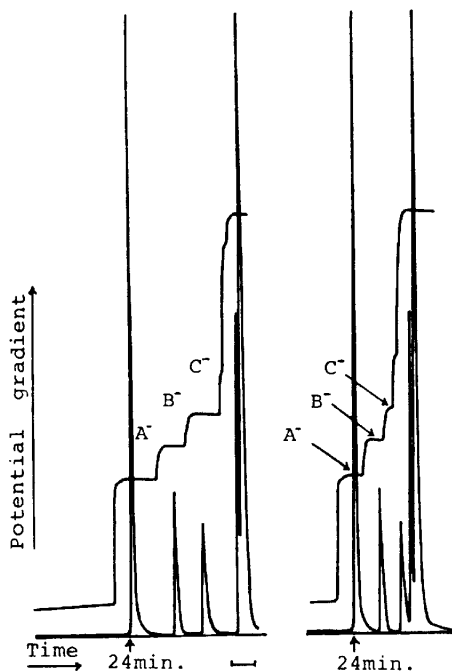

Fig. 4. Maximal withdrawal amount of a target component. Citrate, lactate, and succinate were analyzed as for Fig. 5 (left side of diagram).

In all cases, the results for the withdrawal volume of the target component showed very good reproducibility, the coefficient of variation being less than 3%.

Limiting quantities of ion in a sample. In this experiment, the IP-1B isotachopheretic analyzer was used under the conditions shown in Table 1. A mixture of 0.01 M solutions of citrate, lactate, and succinate was prepared and used as a mixed sample containing more than 3 μ l of each solution. The components formed mixed zones between A⁻ and B⁻, and between B⁻ and C⁻ (indicated by the arrows in Fig. 5).

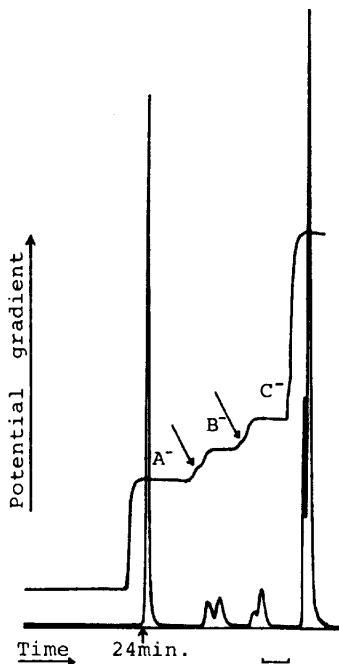

Fig. 5. Mixed zone formation.

DISCUSSION

Isotachopheresis is an electrophoretic technique which gives excellent qualitative and quantitative results for ionic species. Of the various types available, capillary type isotachopheretic analysis was developed by Martin *et al.* (4) in 1967 and has come into general use since 1973. Such analysis has extended to most of the substances that possess an electric charge, and includes organic acids (7, 10, 11), amino acids (12-14), and metallic ions (15).

In the present study, a microsyringe was inserted into a specialized ipp-1 model withdrawal cell which incorporates a PGD and is attached to the Shimadzu IP-1B model capillary type isotachopheresis apparatus. The specific characteristics of this ipp-1 model withdrawal cell have been reported by Koba-

yashi *et al.* (9). They report that cutting off the migration current to withdraw a component does not cause any dispersion of the migration boundaries of a component for an interval of at least 30 min.

Analysis of sodium citrate, lithium lactate, and sodium succinate under the conditions shown in Table 1 gave the migration pattern seen in the left of Fig. 3. Individual components were identified as citrate, lactate, and succinate by comparison of the electrical gradients of 0.01 M solutions of sodium citrate, lithium lactate, and sodium succinate analyzed by isotachopheresis separately.

The recovery rate of components withdrawn in the present experiments was up to 45 % for pure target components (Fig. 3, right). Even when mixture of adjoining components was included to enable withdrawal of as much of a single component as possible, the best recovery rates did not exceed 78 % (Fig. 4, right). The low values for recovery rates are probably explained by the fact that withdrawal with a microsyringe only allows movement, and therefore withdrawal, of fluid in the central portion of the tube as Kobayashi *et al.* (9) suggest. It is difficult to make the fluid along the walls of the tube move. The limit for analysis of individual components of a 0.01 M solution was around 3 μ l. If this volume was exceeded, the ion quantity was too large for the volume of the microcapillary tube and, as Fig. 5 shows, mixed zones formed such that complete separation, and thus the analysis, of individual components became impossible.

If the components have equal mobility, it is not accurate to use only the potential gradient detector to identify individual components, but, in the present study, there was very little variation in the results for the withdrawal volumes of individual migration components, so it is now possible to use the samples obtained through this withdrawal cell for more accurate identification of the individual components by other conventional enzyme or thin layer chromatography techniques.

REFERENCES

1. Arlinger, L.: Analytical isotachopheresis. Resolution, detection limits and separation capacity in capillary columns. *J. Chromatogr.* **91**, 785-794, 1974.
2. Haruki, T. and Akiyama, J.: A new potential gradient detection system for isotachopheresis. *Anal. Lett.* **6**, 985-992, 1973.
3. Akiyama, J. and Mizuno, T.: Sensitivity of a newly designed potential gradient detector for isotachopheresis. *J. Chromatogr.* **119**, 605-608, 1976.
4. Martin, A.J.P. and Everaerts, F.M.: Displacement electrophoresis. *Anal. Chem. Acta* **38**, 233-237, 1967.
5. Van der Steen, C., Everaerts, F.M., Verheggen, Th.P.E.M., and Paulis, J.A.: AC conductivity measurements in isotachopheresis. *Anal. Chim. Acta* **59**, 298-308, 1972.
6. Everaerts, F.M. and Verheggen, Th.P.E.M.: High-resolution isotachopheresis by means of direct conductivity measurements with miniature sensing electrodes. *J. Chromatogr.* **73**, 193-210, 1972.
7. Stankoviansky, S., Čičmanec, P., and Kaniansky, D.: Conductivity detection of zones in

- isotachopheresis with a high-frequency bridge. *J. Chromatogr.* **106**, 131-138, 1975.
8. Arlinger, L.: Preparative capillary isotachopheresis. Principle and some applications. *J. Chromatogr.* **119**, 9-24, 1976.
 9. Kobayashi, S., Shiogai, Y. and Akiyama, J.: Preparative methods in capillary isotachopheresis. Isotachopheresis, *Proc. 2nd Int. Symp. Isotachopheresis. Eindhoven, September 9-11, 1980*, Elsevier, Amsterdam, Oxford, New York. pp. 57-53, 1981.
 10. Beckers, J.L., and Everaerts, F.M.: Isotachopheresis. The qualitative separation of anions. *J. Chromatogr.* **69**, 165-179, 1972.
 11. Boček, P., Lekova, K., Deml, M., and Janak, J.: Separation of some typical Krebs cycle acids by high-speed isotachopheresis. *J. Chromatogr.* **117**, 97-104, 1976.
 12. Everaerts, F.M. and Van der Put, A.J.M.: Isotachopheresis. The separation of amino acids. *J. Chromatogr.* **52**, 415-419, 1970.
 13. Kopwillen, A. and Lundin, H.: Analytical isotachopheresis X: amino acid analysis. *Application Note* **183**, 1-7, 1974.
 14. Shiogai, Y., Yagi, T., and Akiyama, J.: Analysis of theanine, glutamic acid and aspartic acid in green tea by capillary tube isotachopheresis. *Bunseki Kagaku* **26**, 701-705, 1977 (In Japanese).
 15. Beckers, J.L. and Everaerts, F.M.: Isotachopheresis. The qualitative separation of cation mixtures. *J. Chromatogr.* **68**, 207-230, 1972.