

*Engineering*

*Industrial & Management Engineering fields*

---

Okayama University

Year 2003

---

Three-dimensional localization and  
mapping for mobile robot in disaster  
environments

Keiji Nagatani  
Okayama University  
Satoshi Yamanaka  
Okayama University

Hiroshi Ishida  
Okayama University  
Yutaka Tanaka  
Okayama University

This paper is posted at eScholarship@OUDIR : Okayama University Digital Information  
Repository.

<http://escholarship.lib.okayama-u.ac.jp/industrial-engineering/73>

## Three-dimensional Localization and Mapping for Mobile Robot in Disaster Environments

Keiji Nagatani

The Graduate School of Natural Science  
and Technology, Okayama University  
3-1-1 Tsushima-naka, Okayama 700-8530  
Japan

Satoshi Yamanaka

Department of Systems Engineering,  
Okayama University  
3-1-1 Tsushima-naka, Okayama 700-8530  
Japan

Hiroshi Ishida

The Graduate School of Natural Science  
and Technology, Okayama University  
3-1-1 Tsushima-naka, Okayama 700-8530  
Japan

Yutaka Tanaka

The Graduate School of Natural Science  
and Technology, Okayama University  
3-1-1 Tsushima-naka, Okayama 700-8530  
Japan

**Abstract**— To relieve damages of earthquake disaster, “The Special Project for Earthquake Disaster Mitigation in Urban Areas” have been kicked off in Japan. Our research group is a part of the sub-project “modeling of disaster environment for search and rescue” since 2002. In this project, our group aims to develop a three-dimensional mapping’s algorithm that is installed in a mobile robot to search victims in a collapsed building. To realize this mission, it is important to map environment information, and also the mapping requires localization simultaneously. (This is called “SLAM problem”.)

In this research, we use three-dimensional map by laser range finder, and we also estimate its location in a global map using correlation technique. In this paper, we introduce our localization and mapping method, and we report a result of preparatory experiment for localization.

### I. INTRODUCTION

From the influence of the “the great Hanshin-Awaji earthquake” which happened in 1995, many researches related to rescue robotics have been performed recently. In this background, “The Special Project for Earthquake Disaster Mitigation in Urban Areas” have been kicked off in Japan. A complex of robotics research groups is charged one of the pillar of that project to relieve disasters by robotic technology.

Our research group have been charged a part of the sub-projects in “modeling of disaster environment for search and rescue” since 2002. In this project, our group aims to develop a three-dimensional mapping’s algorithm that is installed in a mobile robot to search victims in a collapsed building.

A target environment of our research is a “a narrow ditch leading to wide space” in a collapsed building. According to a rescue dog trainer, one of requirements to search victims is that a rescue dog should pass through a partial broken narrow ditch in disaster field (such as collapsed buildings). It is a very stressful and danger job

for dogs and the trainers. Therefore, we assume such environment as our target environment.

In such environment, many robotic technologies are required for “search and rescue” by mobile robots, and we focus on following topics in this research.

- 1) Localization in three-dimensional space
- 2) Mapping three-dimensional environment

In an unknown environment, the above topics are complement to each other. That is because a robot must localize itself in partially mapped environment. In Figure 1, we introduce the idea of our localization method. A robot acquires local information in (1), localizes in partial mapped environment in (2), and expands the environment information in (3). To acquire local environment information, we use a laser range finder mounted on a mobile robot.

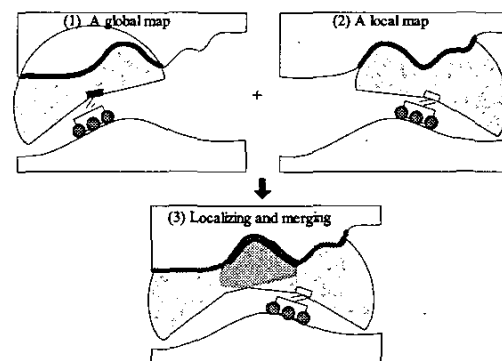

Fig. 1. Introduction to our localization method

In this paper, we introduce an algorithm that maps an environment and localizes mobile robot’s position in three-dimension. We also report a result of a preparatory experiment to verify the algorithm.

## II. RELATED WORKS

This research relates to following research fields.

In the research field of “search and rescue robotics”, many of research topics are focused on a mechanism to overcome uneven grounds. Hirose et al. proposed “snake type’s mobile robot”[1] and “Gunryu (several mobile robots with arm overcome rocks by cooperation among them)”[2] for search and rescue tasks. Murphy proposed a parent-and-child robot [3]. The parent mobile robot can navigate on uneven ground, and the child robot (that is getting ready in the parent’s inside) can explore some places like cliffs using its rope connecting to the parent robot. Many of mobile robots for search and rescue (including above robots) have a crawler mechanism for locomotion that can overcome uneven grounds. We have also chosen such crawler type of mobile robot as our research platform. However we focus on a research of localization and mapping instead of a locomotion mechanism.

In the research field of “localization and mapping”, recently SLAM (simultaneous localization and mapping) is a popular algorithm. Thrun et al. systematized a SLAM algorithm for multiple mobile robots with Bayesian method, and successfully implemented in mobile robots in two-dimensional environments [4]. Choset et al. proposed a SLAM algorithm using “generalized Voronoi graph” [5]. It was also successfully implemented in mobile robots in two-dimensional environment. In our approach, a target environment is three-dimensional space. A robot acquires a local environment information, and estimates its position in a partially mapped global map using correlation technique.

In “representation of environment”, a three-dimensional polygon method is used in a research field of computer graphics. Representation using cubic grids is also a basic method. However, in the above methods, data size is so huge for representing a large environment that some kinds of data compression method is required for realtime navigation for mobile robots. DEM (Digital Elevation Map) is one of the popular methods to compress information of three-dimensional environment (e.g. in [6]). It can represent an uneven ground by planar grids, and each grid has depth information. Unfortunately, it is impossible for DEM to express unevenness of both ceiling and ground. In our research, we use a S-DEM (Sphere-DEM) to represent a local environment, and global map is represented by relative locations of several S-DEMs.

## III. LOCALIZATION AND MAPPING METHOD

To explore an unknown environment, a mobile robot needs to map the environment and to localize in the built map simultaneously (it is called “SLAM”). In uneven ground (such as inside of a collapsed building), “geographical features” are good information for three-

dimensional localization of the robot. Therefore, we adopt the following method for SLAM of mobile robot.

- 1) Moving a suitable distance from the last sensing point
- 2) Sensing three-dimensional range data
- 3) Building a local map (that is represented by three-dimensional range information from the robot’s location)
- 4) Comparing between the local map and the pre-constructed global map
- 5) Localizing the robot’s position in the global map
- 6) Adding the local map information to the global map according to the robot’s estimated position
- 7) Returning to 1

In following sub-sections, we introduce details of the above method.

### A. Acquisition of three-dimensional range data

We assume that the robot has a laser range finder to construct a local map. A conventional laser range finder can detect a range in a plane, so we rotate the sensor on an axis parallel to the plane for acquiring three-dimensional data. Figure 2 shows an idea of this method. Using this method and slope sensors, the robot can detect a three-dimensional range data relative to the global horizontal plane.

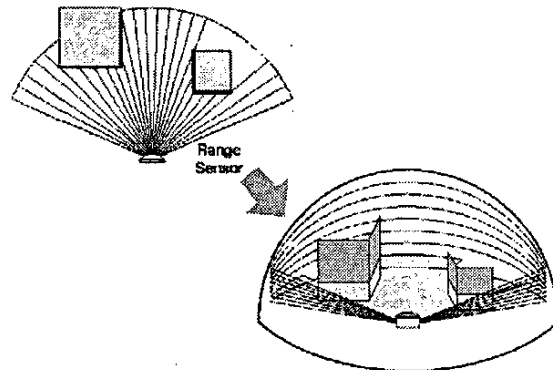

Fig. 2. Acquisition of three-dimensional environment data

### B. Sphere digital elevation map (S-DEM)

To represent a local map by standard grids (or boxels) requires huge memory area in three-dimensional environment. For saving computer resources, it is popular method for representation of uneven ground to use a digital elevation map (DEM). The map uses two-dimensional grids on a horizontal plane of the world, and each grid has height information to represent three-dimensional world. Unfortunately, it is difficult to represent a space like a “a narrow ditch leading to wide space” that can exist inside of collapsed buildings.

In this research, we use sphere-DEM (S-DEM) to represent a local map. S-DEM is one of the type of elevation maps, however each height information is stored in a grid on the sphere's surface instead of on the flat plane. Each sensing point is represented by  $r(\theta, \phi)$ , and the sensor's location is the center of the sphere. Figure 3 shows an example of S-DEM in a two-dimensional case.

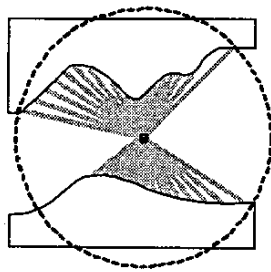

Fig. 3. Construction of sphere digital elevation map (S-DEM)

### C. Localization method

Using S-DEM representation, a global map is represented by several S-DEMs and relative locations among them. Also robot's localization is performed by detecting a relative location between one of S-DEMs in the global map and a S-DEM at the current robot's position.

To calculate a relative location between two S-DEMs, we use a correlation technique using the following method. Firstly, we transform each boundary position  $r_{gl}(\theta, \phi)$  of S-DEM in the global map into Descartes coordination  $(x, y, z)$ . Secondly, we move the S-DEM's origin  $(x_g, y_g, z_g)$  to an arbitrary position  $(x_v, y_v, z_v)$ . Then, we generate each virtual boundary position  $r'_v(\theta'_v, \phi'_v)$  using  $(x, y, z)$  to generate a virtual S-DEM that center is  $(x_v, y_v, z_v)$ . Finally, the correlation between the virtual S-DEM and the local S-DEM is calculated by the following,

$$d = \sum_{\theta} \sum_{\phi} (r'_v(\theta'_v, \phi'_v) - r_{lc}(\theta, \phi))^2 \quad (1)$$

where  $r_{lc}(\theta, \phi)$  is a boundary position of S-DEM in a local map.

Then, the location  $(x_v, y_v, z_v)$  that minimizes a value of  $d$  is the relative location between the global S-DEM and the local S-DEM.

Figure 4 shows an example to construct virtual S-DEM in a two-dimensional case. In the left figure, S-DEM is represented by a group of gray segments, and thick black curves mean detected boundaries of the environment. The upper boundary is divided into two curves because of occlusion. When the origin of S-DEM is virtually moved to the lower left, a virtual S-DEM is constructed as the right figure.

Once the robot calculates values of correlation  $d$  in (1) at every candidates of virtual S-DEM's origin  $(x_v, y_v, z_v)$ , the robot knows its location by picking up the minimum value of  $d$ .

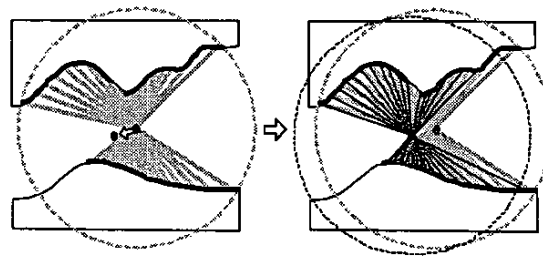

Fig. 4. An example of virtual S-DEM

If the robot uses only range sensor data for localization (and assumes many candidates of position and orientation), it costs too much calculation time. Practically, we assume that the robot uses "gyro sensor with compass" for detecting an orientation (and a pose) of the robot to reduce the cost. Then it estimates  $x-y$  location and altitude using above algorithm.

### D. Expanding global map

Once the robot knows a location in the global map, it merges the local S-DEM information for expanding the global map. A detail of the merging method is not determined yet. (It is one of our future works.)

## IV. HARDWARE

Currently, we are setting up a sensor unit and a crawler type mobile robot for experiments.

### A. Sensor unit

An objective of a sensor unit mounted on our mobile robot is to detect environment information relative to a horizontal plane of the ground in the target environment. Therefore, we designed a sensor unit that consists of the following functions.

- 1) a laser range finder (produced by SICK)
- 2) a gyro sensor unit (produced by NEC Tokin)
- 3) an actuator to lift the laser range finder
- 4) an actuator to rotate the laser range finder

An overview of the sensor unit is shown in Figure 5.

#### 1) Laser range finder

A laser range finder (LRF) has a capability to detect a range up to 8 meters within 5 millimeters' errors. We trust a range up to 3 meters because an angular error becomes large at a farther detection point.

#### 2) Gyro sensor unit

A gyro sensor unit (produced by NEC-Tokin) includes not only gyros but a geomagnetism sensor to cancel drift errors in gyros. It can detect three rotational angles around rectangular coordinates  $(\phi_x, \phi_y, \phi_z)$ .

#### 3) A lifting mechanism

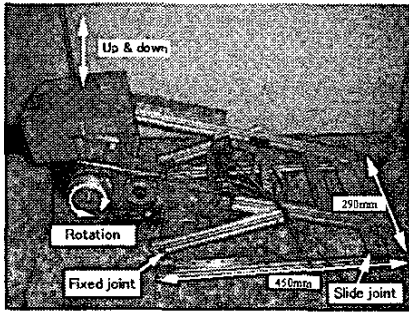

Fig. 5. An overview of our sensor unit

We also added a function to lift the laser range finder. When a robot enters a narrow ditch, the height of it should be low. However, in wide space, it is better for the robot to detect environment information by the sensor at higher position. Therefore, we designed a mechanism to lift the laser range finder. The lifting mechanism includes slide joints, fixed joints, a trapezoidal screw and a DC-motor. An overview of the mechanism is shown in Figure 6.

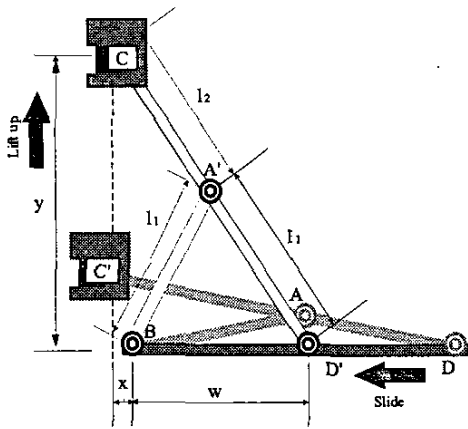

Fig. 6. A lifting mechanism of a laser range finder

The position of the laser range finder  $(x, y)$  is simply calculated by a kinematics of following equation using parameters shown in Figure 6,

$$x = \left( \frac{l_2 - l_1}{l_1} \right) \cdot w \quad (2)$$

$$y = \frac{l_1 + l_2}{2l_1} \sqrt{(4l_1^2 - w^2)} \quad (3)$$

where the length of  $w$  is detected by an encoder attached to the DC-motor.

All functions of the sensor were designed to be performed automatically. However, in our current implemen-

tation, we operate sensors manually.

### B. Mobile robot (crawler type)

To mount the sensor unit, we developed a crawler type's mobile robot. It consists of two crawlers, two motors, batteries and a control computer. Basically, we consider a partial autonomous searching task instead of full-autonomous navigation. Figure 7 shows a photograph of the robot. Now we are setting up the controller of sensor unit.

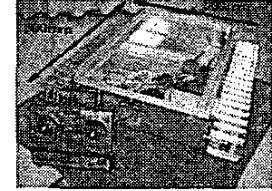

Fig. 7. A crawler type mobile robot

## V. PREPARATORY EXPERIMENT

### A. Target environment

Currently, we do not have a test field of collapsed building, hence the experiment has been carried out in a simple indoor environment. Figure 8 shows a target environment in this experiment. It includes a flat floor with several obstacles. We also assume that a pose of the sensor unit is not always parallel to the horizontal plane of the ground. Therefore, the sensor unit should measure its inclination by the gyro sensor.



Fig. 8. A target environment

### B. Procedure of experiment

To confirm validity of our localization algorithm using our sensor unit, we have performed a simple preparatory experiment as follows.

- (P-1) Firstly, we locate the sensor unit parallel to the ground, and the initial location of the unit is defined as the origin of the global coordinates. Then it scans range data from  $-45[deg]$  to  $40[deg]$  (horizontal direction is equal to  $0[deg]$ ) in tilting angle in every  $1[deg]$ . At each angle, the sensor can measure range data of panning angle (from  $-90[deg]$  to  $90[deg]$ ) in every  $1[deg]$ . In this experiment, the tilting angle is measured by the gyro sensor unit. Thus the range data is stored into a S-DEM in the global map  $r_{gl}(\theta, \phi)$ .
- (P-2) Secondly, we move the sensor unit to a certain distance (and certain pose). Then the sensor unit scans local data again (it is the same as the first procedure), and the data is stored into a S-DEM in the local map  $r_{lc}(\theta, \phi)$ .
- (P-3) Thirdly, we generate virtual S-DEMs from the global S-DEM to produce candidates of robot's positions. In this experiment, candidates of the origin of virtual S-DEM are located in  $(-50 < x < 50)$ ,  $(-30 < y < 60)$ ,  $(-10 < z < 10)$ .
- (P-4) Finally, we find the minimum value  $d$  in the equation (1), and it is the estimated location of the current sensor unit. Then we compare the estimated location and the measured location.

### C. Experimental result

At the first location of the sensor unit, we detected environment information using (P-1). Then we constructed the first S-DEM of the global map using the data of the laser range finder.

Figure 9 shows a raw information of the laser range finder.

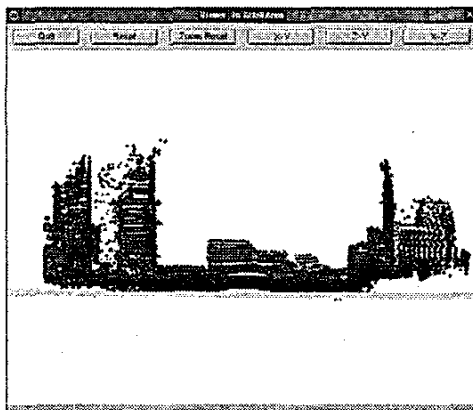

Fig. 9. A result of laser range data

It is very difficult to illustrate S-DEM because each depth from boundary is extended from the origin of the sphere. So, we sliced the S-DEM at the  $\theta = -30[deg]$

(horizontal direction is equal to  $0[deg]$ ) shown in Figure 10. In this figure, an unknown area is illustrated as gray areas.

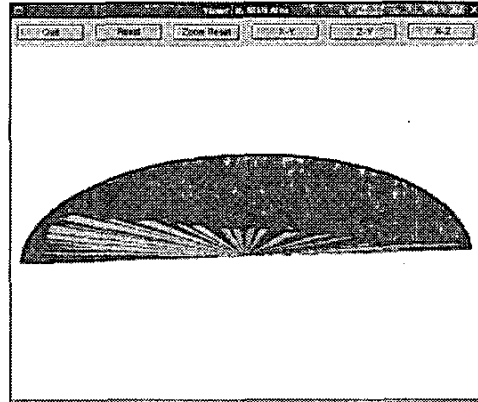

Fig. 10. An sliced S-DEM ( $\theta = -30[deg]$ ) in the global map

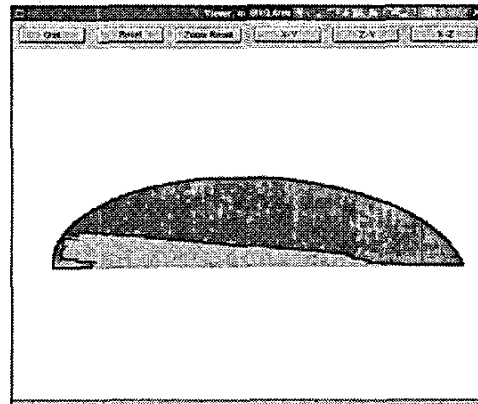

Fig. 11. An sliced S-DEM ( $\theta = -30[deg]$ ) in a local map

In the second step, we moved the sensor unit to the location of  $(x = 22, y = 36, z = 5)[cm]$ , and the pose of the unit is the same. Then we measured environment data (P-2), and calculated correlations (P-3) (P-4). The estimation result was calculated at  $(x = 23, y = 35, z = 3)[cm]$ . It is almost matched as the measured location. Figure 11 shows a sliced S-DEM at the  $\theta = -30[deg]$ . We can see that the shape of the free space at the bottom of this figure is matched to the same place in Figure 10.

Next, we suppose that the robot stepped on a rock, shown in Figure 12. The moved location is the same as the last experiment  $(x = 22, y = 36, z = 5)[cm]$ , and the tilted angle of the body is  $8[deg]$ .

The result of the estimated location is  $(x = 24, y = 35, z = 3)[cm]$ , and it is almost the same as the measured location.

In these experiments, the grid size in re-calculation for virtual S-DEM is  $1cm$ . Therefore I suppose that these are

reasonable results from the point of view of accuracy.

On the other hand, we had an experience that an estimated position along z axis was not accurate. It is unavoidable in this experiment because we use range data from  $-45[deg]$  to  $40[deg]$  in tilting motion, and does not use a ceiling information. In our intuition, the robot can localize more accurately by using full-size S-DEM.

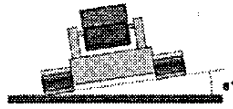

Fig. 12. A tilted pose of the robot

## VI. CONCLUSION AND FUTURE WORKS

In this paper, we proposed a concept of S-DEM to represent environment information and to localize in partially developed map. According to our preparatory experiments, the robot can estimate its location in a collapse building.

We still have the following future works. One of the important future work is to set up the mobile platform with the constructing sensor unit to verify proposed methods of localization and mapping. Another future work is to discuss a viewing method of detected environment information for a human. Finally, we will try to apply our system to the test field of "disaster environment" in Kobe.

## VII. ACKNOWLEDGMENTS

This research is fully supported by "The Special Project for Earthquake Disaster Mitigation in Urban Areas" in the Japanese Ministry of Education, Culture, Sports, Science and Technology.

## VIII. REFERENCES

- [1] E. F. Fukushima and S. Hirose, "An efficient steering control formulation for the articulated body mobile robot "kr-ii";" *Autonomous Robots Vol.3 (1)*, pp. 7-18, 1996.
- [2] E. F. F. Shigeo Hirose, Takaya Shirasu, "Proposal for cooperative robot "gunryu" composed of autonomous segments," *Robotics and Autonomous Systems, Elsevier, 17*, pp. 107-118, 1996.
- [3] R. Murphy, M. Ausmus, M. Bugajska, T. Ellis, T. Johnson, N. Kelley, J. Kiefer, and L. Pollock, "Marsupial-like mobile robot societies," *IEEE Intelligent Systems 15(3)*, pp. 364-365, 1999.
- [4] S. Thrun, "A probabilistic online mapping algorithm for teams of mobile robots," *International Journal of Robotics Research*, vol. 20, no. 5, pp. 335-363, 2001.
- [5] H. Choset and K. Nagatani, "Topological simultaneous localization and mapping (slam): toward exact localization without explicit localization," *IEEE Trans. on Robotics and Automation*, vol. 17, no. 2, pp. 125-137, 2001.
- [6] J. R. Collins, Y. Tsin and A. Lipton, "Using a dem to determine geospatial object trajectories," in *DARPA Image Understanding Workshop*, pp. 115-122, 1998.