

## Effects of Basic Slag, Aggregate Size and Groundwater Treatments on the Production of Chilli in Acid Sulfate Soils in a Simulation Study

Md. Harunor Rashid KHAN<sup>\*</sup> \*\*, Syed Monzur KABIR<sup>\*\*</sup>, Md. Mukaddas Ali BHUIYAN<sup>\*\*</sup> and Hans-Peter BLUME<sup>\*\*\*</sup>

A simulation study was conducted to evaluate the effects of basic slag (BS<sub>10</sub> and BS<sub>20</sub>: basic slag 10 and 20 t ha<sup>-1</sup>), aggregate size (A<sub>20</sub> and A<sub>30</sub>: aggregate sizes of soil, less than 20 and 20-30 mm) and groundwater depth (Gw<sub>0</sub>: no influence of groundwater and Gw<sub>50</sub>: groundwater beneath 50 cm of the soil surface) as physico-chemical amendments in two pre-leached (leached for a week through tap water to remove excessive acidity and salinity from the soil before transplantation) acid sulfate soils of Badarkhali (Salidic Sulfaquept) and Cheringa (Typic Sulfic Halaquept) series in relation to the production of Chilli (*Capsicum annum* L.). Maximum growth and yield of chilli were recorded by the treatment combining A<sub>30</sub>Gw<sub>50</sub>BS<sub>20</sub> in both the Cheringa (green chilli weight: 4.82 t ha<sup>-1</sup>) and Badarkhali (4.51 t ha<sup>-1</sup>) soils. The application of basic slag (BS<sub>20</sub>) was found to be the most effective among the individual treatments, followed by the BS<sub>10</sub> > A<sub>30</sub> > Gw<sub>50</sub> treatments. The application of BS<sub>20</sub> increased the yield in combination with the Gw<sub>0</sub> treatment by 40% for A<sub>20</sub>, while by 107% for A<sub>30</sub> in the Badarkhali soil. On the other hand, in the case of Gw<sub>50</sub>, these increments were 49 and 141% for A<sub>20</sub> and A<sub>30</sub>, respectively. The application of BS at the highest rate (BS<sub>20</sub>) to the Cheringa soil was more effective compared with the A<sub>20</sub> and A<sub>30</sub> treatments in the Badarkhali soil. The same rate of BS<sub>20</sub> in combination with the Gw<sub>50</sub> treatment increased the yield by 59 to 147% in the Cheringa soil compared with 49 to 141% in the Badarkhali soil. Almost similar and significant (p≤0.05) effects were observed for the other growth parameters of chilli cultivated in both soil series.

**Key words:** aggregate size, basic slag, groundwater, growth and yield of chilli, physico-chemical amendments of acid sulfate soils.

### 1 INTRODUCTION

Acid sulfate soils (ASSs) can exert severe effects on surrounding ecosystems and immediate steps should be taken to protect the soils. Delayed effects of potential chemicals stored in the ASSs resulted in harmful effects, like a “chemical time bomb” on the associated environments (Khan and Adachi, 1999). Potential ASSs may have high pH like 6 to 7, which does not mean that the soils are safe. Because, such a situation may create H<sub>2</sub>S, Fe, some organic acids and CO<sub>2</sub> problems. The weathering of sulfidic overburdens and mine spoils present the same problems (Orndorff and Daniels, 2002). The reclamation of these soils may be difficult, but essential (Khan, et al. 2006). Successful reclamation of the ASSs may result in the development of productive fields for crop growth. While poor soil reclamation may lead to creation of unfavorable soil conditions for crop growth and formation of ASSs, the real problem lies in the coastal tidal flat plain areas (Khan, et al. 2007).

About 24 M ha of land is covered by ASSs through-

out the world (Van Mensvoort and Dent, 1998), of which about 0.7 M ha are located in the coastal areas of Bangladesh where crop production is very low; somewhere the lands are unproductive, though the lands have high agricultural potential (Khan, 2000). Leaching treatments may alleviate the problems but these practices lead to the deterioration of the fertility status of soils and/or related ecosystems and to permanent soil acidification through exchange reactions between acidic-basic cations (Khan and Adachi, 1999). It was also confirmed that leaching couldn't be an effective and sustainable method of crop production in the ASSs, unless this practice followed by the addition of materials rich in basic cations like basic slag (Khan, et al. 1994; 1996). Basic slag as a byproduct from the steel industry in Bangladesh can be collected almost free of charge. Moreover, the basic slag had a very high pH of 9.6 and contained 208 g kg<sup>-1</sup> Ca, 98 g kg<sup>-1</sup> Mg, and 12.8 g kg<sup>-1</sup> SiO<sub>2</sub> (Khan, et al. 2006). They also reported that the use of basic slag was found to be harmless in Bangladesh since 1985. To achieve the highest rate of oxidation and effective drainage of sulfidic materials in heavy-textured ASSs, the aggregate sizes of the soils should be reasonably smaller for the higher rate of release of

\*Department of Environmental Management Engineering, Faculty of Environmental Science and Technology, Okayama University.

\*\*Department of Soil, Water and Environment, University of Dhaka.

\*\*\*Institute for Plant Nutrition and Soil Science, University of Kiel, Germany.

acidity-salinity and toxic elements from the soils, which may enhance crop production.

Chilli (*Capsicum annum* L.) is a solanaceous plant bearing fruit/vegetable, commonly used for preparing hot foods, vegetable curries, etc. The genus *Capsicum* is derived from Greek term *Kapto* means 'to bite' and *annum* meaning annual. Chilli is third most important crop of family solanaceae after potato and tomato. Chillies are grown on large scale as a cash crop, occupying the large area in Bangladesh. However, per hectare yield of chillies is quite low in Bangladesh compared to other agriculturally advanced countries. Today there are probably 400 different chillies grown, and are one of the most widely cultivated crops today, grown from the Far East, China, Japan, Thailand, Indonesia and India to Mexico. Chilli has also medicinal value. Chillies are loaded with vitamin A, a potent antioxidant and boost to the immune system. As the pods mature and darken, high quantities of vitamin C are gradually replaced with beta carotene and the capsaicin levels are at their highest. Due to these capsaicin levels, some believe that eating chillies may have an extra thermic affect, temporarily speeding up the metabolic rate, hence burning off calories at a faster rate. Whatever, you certainly do sweat and actually cool down in hot climates as sweat evaporates. Your nose runs, your head clear ... you can breathe! And with that extra flow of saliva, the gastric juices also flow. The alkaloids from the capsaicin stimulate the action of stomach and intestine improving the whole digestion process! Beyond soothing gastric wonders and taste delights, the very nature of fiery capsaicin has been medicinally beneficial down through the ages and put to use for some chronic health woes. These same heat inducing properties have a cumulative effect and over time are believed to alleviate pain when used in transdermal treatments for arthritis, nerve disorders (neuralgia), shingles and severe burns ... even cluster headaches. The mucus thinning properties promote coughing and can act as an expectorant for asthmatic conditions. Other claims are boosts to the immune system due to the antioxidants, lowering cholesterol, and blood thinning properties beneficial for the heart and blood vessels ([http://www.chilliesgalore.co.uk/pages/chilli\\_facts.html](http://www.chilliesgalore.co.uk/pages/chilli_facts.html)).

Scientists claimed that the hottest chilli on Earth is Indian (Newspaper article 05/09/2000; New Delhi). In Bangladesh, the chillies grow in temperatures of well over 100°F (38°C). Aktar Miah from the Indus Bangladesh restaurant in Bournemouth said that even in its home country it is treated with respect. 'It is used in some cooking mainly in fish/meat curries. Somebody hold it by the stalk and just touch their food with it 'he said. It has a refreshing smell and a very good taste but you don't want too much of it. It is a killer chilli and you have to be careful and wash your hands and the cutting board. If you don't know what you are doing it could blow your head off. (The Times Newspaper article 01/04/2006). Chillies grow well in acid soils. Accordingly, the nutrient-enriched ASSs deserve attention to use these soils for chilli production after proper reclamation. Against this background, the

objectives of the present study were to evaluate the effects of basic slag application rate, aggregate size and groundwater level treatments on the growth and yield of chilli cultivated in acid sulfate soils in a simulation study.

## 2 MATERIALS AND METHODS

### 2.1 Soil Collection

For the simulation studies using concrete tanks, acid sulfate soils from the 1<sup>st</sup> layer (0-20 cm), 2<sup>nd</sup> layer (20-40 cm) and 3<sup>rd</sup> layer (40-60 cm) of fallow land (crop production is impossible due to severe acidity and salinity) of Badarkhali (B) and Cheringa (C) series were collected, respectively from Purbapukuria (Badarkhali) and Ringbong Sarishaghata (Dulhazara) in the Cox' Bazar district in Bangladesh. These soils occur in the coastal old mangrove floodplain areas of Cox' Bazar. Both the soil series had a silty clay texture and contained yellow mottles of jarosite throughout the studied layers. The second layer was more acidic than the first layer, followed by the third layer. Selected physical and chemical properties of these soil layers were analyzed according to the methods of Klute (1986: **Table 1**). Based on the field and laboratory investigations (for details; Kabir, 2005), both soil series were classified into the Inceptisol order, Aquept suborder and Salidic Sulfaquept (Badarkhali series) and Typic Sulfic Halaquept (Cheringa series) Great group, according to the USDA Soil Taxonomy (Soil Survey Staff, 1999).

### 2.2 Preparation of simulation tanks

The bulk soil samples from 1<sup>st</sup>, 2<sup>nd</sup> and 3<sup>rd</sup> layers were air-dried and crushed into different aggregate sizes to prepare a 60 cm soil bed by arranging the soil layers in the same order as that under field conditions. Effects of the basic slag application rate (BS<sub>10</sub> and BS<sub>20</sub>: basic slag 10 and 20 t ha<sup>-1</sup>), aggregate size (A<sub>20</sub> and A<sub>30</sub>: aggregate sizes of 20, less than 20 and 20-30 mm, respectively) and groundwater level (Gw<sub>0</sub>: no influence of groundwater and Gw<sub>50</sub>: groundwater beneath 50 cm of the soil surface) treatments on the growth and yield of chilli (*Brassica campestris* L.) grown in two pre-leached (explained in the next paragraph) ASSs of the Badarkhali and Cheringa series were evaluated in a simulation experiment. The size of the concrete tank was 0.6 m X 0.6 m X height 0.8 m, i.e. the inside area of each tank was about 0.4 m<sup>2</sup> (**Fig. 1**). The absolute control (A<sub>0</sub>Gw<sub>0</sub>BS<sub>0</sub>) treatment of the experiment has been excluded due to having no data on agronomic parameters of chilli, which was attributed to the severe acidity, and salinity problems of the soil. It is also mentioned earlier that the soil was collected from the fallow land, where crop production was nil. Moreover, the principal author (Khan, H.R.) who had conducted several preliminary experiments on BS and recommended its economic use at the rates of 10 to 20 t ha<sup>-1</sup> for the ASSs of Bangladesh (Khan, et al. 1994; 1996; 2006). Furthermore, the maintenance of A<sub>0</sub> sizes (no till) was not an effective measure for this soil. Therefore, the A<sub>20</sub>Gw<sub>0</sub>BS<sub>10</sub> (T<sub>1</sub>) treatment was used as experimental control for the present simulation study. The experiment was conducted in the polyethylene house at the premises of

**Table 1** Some selected physical and chemical properties of the acid sulfate soil layers before the simulation study.

Soil properties	Badarkhali series (depth cm)			Cheringa series (depth cm)		
	0-20	20-40	40-60	0-20	20-40	40-60
Textural class	Silty clay loam			Silty clay loam		
Bulk density (Mg m <sup>-3</sup> )	1.10	1.12	1.15	1.03	1.06	1.11
Moisture at Field Capacity (Vol. %)	46	48	47.6	49	51	52
Soil pH (Field, 1:2.5)	4.2	3.9	4.3	3.9	3.4	4.1
Soil pH (Dry, 1:2.5)	3.9	3.5	3.9	3.6	3.3	3.9
Soil pH (0.02 M CaCl <sub>2</sub> , 1:2.5)	3.4	3.1	3.6	3.2	2.9	3.3
Soil pH (H <sub>2</sub> O <sub>2</sub> , 1:2.5)	3.2	2.8	3.4	3.1	2.6	3.2
#Pyrite content (%)	6.6	8.4	11.1	7.3	8.8	8.6
ECe (S m <sup>-1</sup> )	1.6	1.5	1.3	1.9	1.7	1.4
Organic Carbon (g kg <sup>-1</sup> )	18.2	17.6	17.4	23.4	21.1	20.7
C / N ratio	15.0	15.3	14.9	16.5	16.3	16.1
Available N (1.3 M KCl: mM kg <sup>-1</sup> )	3.27	3.20	3.17	3.65	3.51	3.43
Avail. P (0.002N H <sub>2</sub> SO <sub>4</sub> , pH 3: mM kg <sup>-1</sup> )	0.11	0.10	0.10	0.10	0.10	0.10
CEC (1 M NH <sub>4</sub> Cl: c mol kg <sup>-1</sup> )	19.6	21.2	20.3	18.2	19.4	18.4
Base saturation at pH 7.0 (%)	24.9	22.	25.6	22.2	19.3	19.5
Al-saturation (1 M KCl: %)	43.2	41.6	34.0	42.4	48.3	42.9
Fe-saturation (1 M NH <sub>4</sub> Cl: %)	7.8	8.0	6.7	8.3	10.0	8.9
Na-saturation (1 M NH <sub>4</sub> Cl: %)	14.8	12.9	15.3	13.4	11.3	11.5
K-saturation (1 M NH <sub>4</sub> Cl: %)	1.5	1.5	1.6	1.4	1.2	1.2
Ca-saturation (1 M NH <sub>4</sub> Cl: %)	2.0	1.7	1.7	1.8	1.4	1.5
Mg-saturation (1 M NH <sub>4</sub> Cl: %)	6.6	6.2	7.0	5.6	5.4	5.3
<b>Water-soluble ions:</b>						
Sodium (flame photometer: c mol kg <sup>-1</sup> )	4.09	3.76	3.42	4.84	4.11	3.81
Potassium (flame photometer: c mol kg <sup>-1</sup> )	0.18	0.17	0.18	0.21	0.22	0.21
Calcium (AAS*: c mol kg <sup>-1</sup> )	0.33	0.32	0.34	0.27	0.29	0.30
Magnesium (AAS: c mol kg <sup>-1</sup> )	3.66	3.84	3.88	3.34	3.49	3.58
Aluminum (AAS: c mol kg <sup>-1</sup> )	1.84	2.11	1.69	2.12	2.51	2.06
Iron (AAS: c mol kg <sup>-1</sup> )	0.30	0.31	0.29	0.33	0.36	0.31
Manganese (AAS: c mol kg <sup>-1</sup> )	0.10	0.08	0.07	0.10	0.09	0.08
Copper (AAS: m mol kg <sup>-1</sup> )	0.007	0.007	0.007	0.009	0.008	0.008
Zinc (AAS: m mol kg <sup>-1</sup> )	0.008	0.009	0.009	0.009	0.009	0.008
Chloride (0.05N AgNO <sub>3</sub> : c mol kg <sup>-1</sup> )	2.60	2.53	2.48	2.86	2.76	2.66
Sulfate (BaCl <sub>2</sub> : c mol kg <sup>-1</sup> )	4.12	4.39	3.97	4.96	5.31	4.83

#Pyrite (FeS<sub>2</sub>) content was calculated from the total content of Fe {(Fe content/46.7) x 100, i.e. FeS<sub>2</sub> was considered to contain 46.7% Fe} in the acid sulfate soils. \*AAS=Atomic Absorption Spectrophotometer.

the Department of Soil, Water and Environment, University of Dhaka during the period for November to March 2004. The experiment was set up in a completely randomized design having three replications for each treatment. The temperatures during experiment were  $25 \pm 4^\circ\text{C}$ . The experimental treatments are listed in **Table 2**.

About 10 kg of air-dried coarse sand, which was previously treated with tap water followed by 1M HCl, and distilled water was put at the bottom of each of the concrete tanks. Thereafter, the soil layers were placed in the concrete tanks according to the following field arrangement: 1<sup>st</sup> layer at the top of the concrete tank, followed by the 2<sup>nd</sup> and 3<sup>rd</sup> layers. The soils amounting to about 70, 30 and 30 kg from the 1<sup>st</sup>, 2<sup>nd</sup> and 3<sup>rd</sup> layers, respectively, i.e., a total of 130 kg soils with aggregate sizes of <20 and 20-30 mm, were placed in the concrete tanks for the treatments. Some of the concrete tanks were designed with facilities aimed at analyzing the effect of groundwater at a depth of 50 cm beneath the soil surface. All the concrete tanks were heavily coated with cement in order to prevent any release of materials. Prior to the transplantation, the soil in each tank was leached through tap water of about 10 L m<sup>-2</sup> each time and this practice was done for 10 times within a week to remove excess salts, i.e. to increase the initial pH<sub>(dry 1:2.5)</sub> of the 1<sup>st</sup> layer from 3.9 and 3.6 to 4.5 and 4.3 for the Badarkhali and Cheringa soils, respectively, and to decrease their initial EC values from 1.6 and 1.9 to 0.13 and 0.15 S m<sup>-1</sup> during transplantation.

Then to the topsoil in each tank, fertilizer containing N, P and K at the rates of 60, 40 and 40 kg ha<sup>-1</sup> as urea, triple super phosphate (TSP) and muriate of potash (MP), respectively, was applied. The full dose of TSP and MP and half of the urea dose were mixed with soil during tank preparation. The remaining half of urea was applied in two equal splits, one at the 50 DAT (days after transplantation) of chilli and the other at the 80 DAT. The topsoils in the concrete tanks were also subjected to the application of basic slag at the rates of 10 and 20 t ha<sup>-1</sup> during soil preparation. Twenty five-day-old healthy and uniform seedlings of Chilli were collected from the Bangladesh agriculture research institute and were transplanted in the 10<sup>th</sup> of November'04. The soils in the tanks were irrigated with tap water, whenever necessary to maintain the topsoil under field moist to dry conditions for chilli production on ASSs. The Gw level was also maintained regularly by using tap water (pH 6.8, EC 0.05 S m<sup>-1</sup>) when required.

### 2.3 Sample collection and analysis

Plant height and leaf area of chilli were determined at 30, 60, 90 and 120 DAT and the fresh weight of green chilli was recorded after first harvesting the chilli at the 120 DAT. The level of significance of the different treatments was determined using Duncan's New Multiple Range Test (DMRT) and least significant difference (LSD) techniques (Zaman, *et al.* 1982).

## 3 RESULTS AND DISCUSSION

### 3.1 Plant height and leaf area

Plant height and leaf area of chilli were found to be increased significantly ( $p \leq 0.05$ ) by the individual application of basic slag, groundwater level and aggregate size treatments, while the combination of these treatments was more effective than the individual treatments for the increase in the plant height and the leaf area of chilli (**Fig. 2**). These effects were more pronounced with the Cheringa soil compared with the Badarkhali soil. Though, the highest value of plant height (86 cm) of chilli at 120 DAT was recorded in the combined BS<sub>20</sub>, A<sub>30</sub> and Gw<sub>50</sub> (T<sub>8</sub>) treatment in the Badarkhali soil, followed by the same (T<sub>16</sub>) treatment in the Cheringa soil. The treatment T<sub>6</sub> (BS<sub>20</sub>A<sub>30</sub>Gw<sub>0</sub>) for Badarkhali soil and T<sub>14</sub> (BS<sub>20</sub>A<sub>30</sub>Gw<sub>0</sub>) for Cheringa soil ranked second in order of the increment of plant height of chilli. The maximum leaf area (28 cm<sup>2</sup>/leaf for Cheringa soil; 23 cm<sup>2</sup> for Badarkhali soil) of chilli at 120 DAT was recorded by the combined BS<sub>20</sub>, A<sub>30</sub> and Gw<sub>50</sub> treatment, followed by the BS<sub>10</sub>A<sub>30</sub>Gw<sub>50</sub> treatment in the soils. The effects of the treatments were quite similar at different growth stages chilli grown in both soil series (**Fig. 2**). Among the individual treatments, the application of basic slag at the highest rate (BS<sub>20</sub>) ranked first, followed by the BS<sub>10</sub> > A<sub>30</sub> > Gw<sub>50</sub> treatment in terms of these plant characters. The response of the plant height and leaf area production to a larger soil aggregate size (A<sub>30</sub>) in the soils was presumably because of the initial slow removal of acidity as well as nutrients that might resulting a better vegetative growth and higher yield. Moreover, the larger soil aggregate size also induced the capillary rise of tap water (pH 6.8, EC 0.05 S m<sup>-1</sup>) used for the maintenance of the Gw level. The average plant height and leaf area of chilli were higher in the Cheringa soil compared with the Badarkhali soil at all stages of growth of chilli (**Fig. 2**). This was possibly due to the initial relatively higher organic matter status in the Cheringa soil, compared with the Badarkhali soil (**Table 1**). Khan, *et al.* (1996) also reported an almost similar effect of basic slag application on the growth of rice cultivated in two saline-acid sulfate soils.

### 3.2 Yield of chilli

The maximum yield of chilli (fresh weight of green chilli: 4.82 t ha<sup>-1</sup> for the Cheringa soil; 4.51 t ha<sup>-1</sup> for the Badarkhali soil: **Table 3**) was recorded by the application of BS<sub>20</sub> t ha<sup>-1</sup> in the soils with larger aggregates (20-30 mm) for a groundwater level of 50 cm beneath the soil surface (T<sub>8</sub> and T<sub>16</sub> = A<sub>30</sub>Gw<sub>50</sub>BS<sub>20</sub>), followed by T<sub>8</sub> > T<sub>14</sub> > T<sub>6</sub> > T<sub>13</sub> > T<sub>5</sub> treatments in both the soils (**Table 3**). The analyses of the data of fresh weight of chilli demonstrated that the average grain yield was higher in the Cheringa soil than in the Badarkhali soil, which was attributed to the initial high contents of organic matter, nitrogen, potassium and sulfur in the Cheringa soil (**Table 1**). The sequence of effectiveness of basic slag application, groundwater level and aggregate size treatments on the yield of chilli (**Table 3**) was almost similar to and as significant ( $p \leq 0.05$ ) as that of the effects

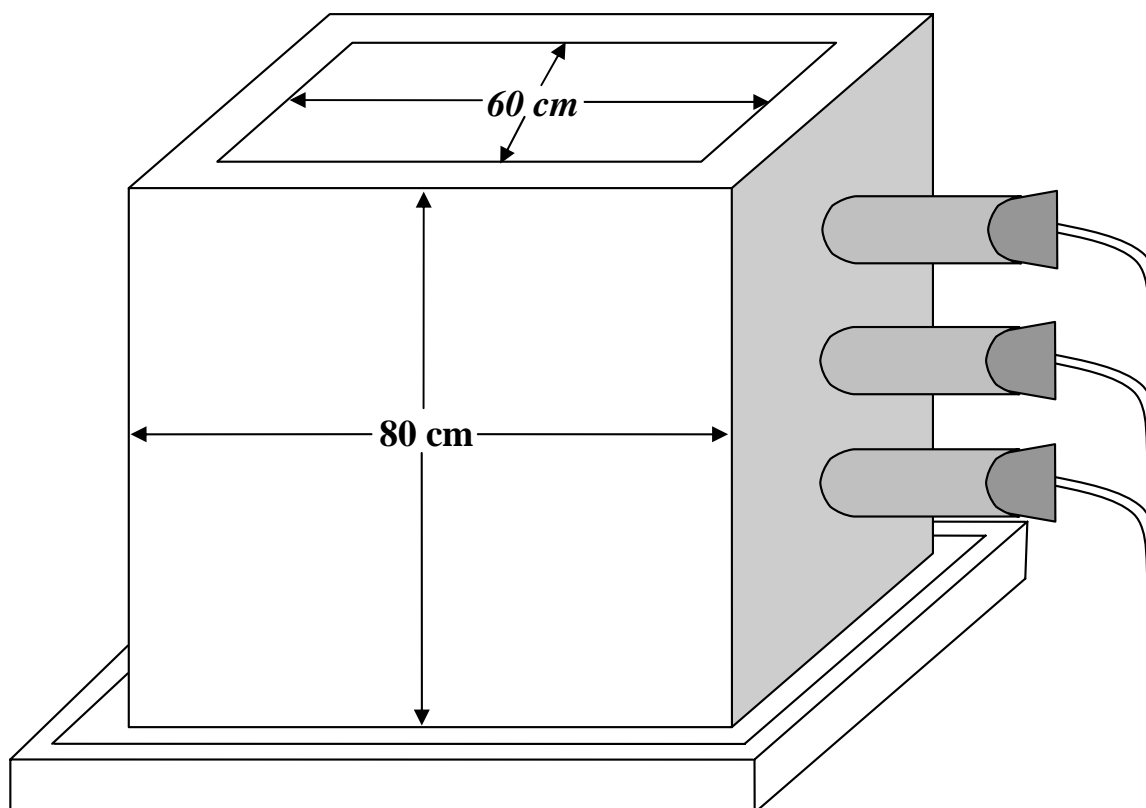

**Fig. 1** Design of concrete tank used for the simulation study

**Table 2** Experimental treatments for the study on acid sulfate soils.

Soils	Treatment No. Denotation	Aggregate size (A: mm)	Groundwater level (Gw: cm)	Basic slag rate (BS: t ha <sup>-1</sup> )
Badarkhali series (B)	T <sub>1</sub> = BA <sub>20</sub> Gw <sub>0</sub> <sup>#</sup> BS <sub>10</sub>	< 20	0	10
	T <sub>2</sub> = BA <sub>20</sub> Gw <sub>0</sub> BS <sub>20</sub>			20
	T <sub>3</sub> = BA <sub>20</sub> Gw <sub>50</sub> BS <sub>10</sub>		50	10
	T <sub>4</sub> = BA <sub>20</sub> Gw <sub>50</sub> BS <sub>20</sub>			20
	T <sub>5</sub> = BA <sub>30</sub> Gw <sub>0</sub> BS <sub>10</sub>	20-30	0	10
	T <sub>6</sub> = BA <sub>30</sub> Gw <sub>0</sub> BS <sub>20</sub>			20
	T <sub>7</sub> = BA <sub>30</sub> Gw <sub>50</sub> BS <sub>10</sub>		50	10
	T <sub>8</sub> = BA <sub>30</sub> Gw <sub>50</sub> BS <sub>20</sub>			20
Cheringa series (C)	T <sub>9</sub> = CA <sub>20</sub> Gw <sub>0</sub> <sup>#</sup> BS <sub>10</sub>	< 20	0	10
	T <sub>10</sub> = CA <sub>20</sub> Gw <sub>0</sub> BS <sub>20</sub>			20
	T <sub>11</sub> = CA <sub>20</sub> Gw <sub>50</sub> BS <sub>10</sub>		50	10
	T <sub>12</sub> = CA <sub>20</sub> Gw <sub>50</sub> BS <sub>20</sub>			20
	T <sub>13</sub> = CA <sub>30</sub> Gw <sub>0</sub> BS <sub>10</sub>	20-30	0	10
	T <sub>14</sub> = CA <sub>30</sub> Gw <sub>0</sub> BS <sub>20</sub>			20
	T <sub>15</sub> = CA <sub>30</sub> Gw <sub>50</sub> BS <sub>10</sub>		50	10
	T <sub>16</sub> = CA <sub>30</sub> Gw <sub>50</sub> BS <sub>20</sub>			20

<sup>#</sup>Composition of Basic slag (%): SiO<sub>2</sub> 12.8, Ca 20.8, Mg 9.8, Fe 11.3, Mn 0.04, PO<sub>4</sub> 0.3, others 44.96 and pH 9.6 (Source: Laboratory of Soil Science, Institute for Plant Nutrition and Soil Science, University of Kiel, D-24109 Kiel, Germany, 1999).

observed on the plant height and leaf area of chilli. The application of BS<sub>20</sub> was found to be the most effective among the individual treatments, followed by the BS<sub>10</sub>, A<sub>30</sub> and Gw<sub>50</sub> treatments for chilli production. The application of BS was reported to be effective due to the

increase in the soil pH and release of some elements such as Ca, Mg into the growing media as well as the large amount of Si, which is beneficial to rice growth (Elawad and Green, 1979; Gashcho, 1977; Khan, et al. 2006). The effect of a larger aggregate size (20-30 mm), compared

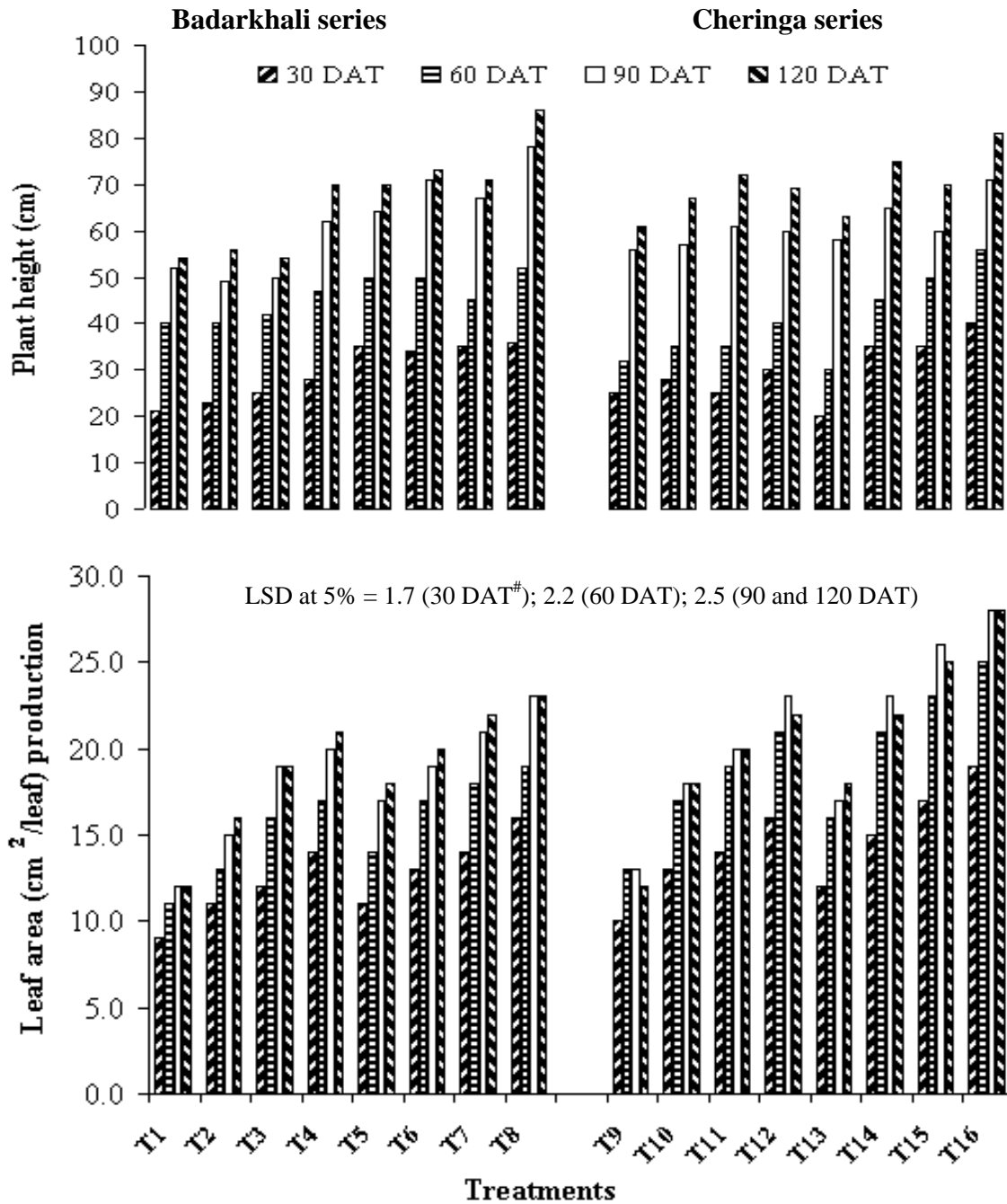

**Fig. 2** Effects of basic slag, aggregate size and groundwater treatments on plant height and leaf area production at different growth stages (DAT#: days after transplantation) of chilli cultivated in two acid sulfate soils

with a smaller (<20 mm) size was more significant for chilli production, which might be due to the maintenance of relatively more favorable conditions associated with the initial slow removal of acidity as well as nutrients and also with the capillary rise of artificial groundwater (applied tap water) at a pH value of 6.8. Table 3 shows that the combined treatment BS<sub>20</sub>, Gw<sub>50</sub> and A<sub>30</sub> not only increased (increased over experimental control = IOEC) the yield (147% in the Cheringa soil, 141% IOEC in the Badarkhali soil) but also exerted significant effects on the other growth parameters of chilli.

#### 4 CONCLUSIONS

The results obtained from study concluded that the application of basic slag, aggregate size and groundwater level treatments alone or in combination exerted significant ( $p < 0.05$ ) positive effects on the growth and yield performance of chilli. The application of basic slag to acid sulfate soils is an effective measure, also available at a reasonable price, which not only enabled to reclaim the soils and improve the growth of the crops, but also was beneficial to the surrounding environment. Moreover, the use of aggregates with different sizes and groundwater management successfully contributed to the adaptation of

**Table 3** Influence of different techniques, basic slag and aggregate size treatments on the yield (fresh weight of green chilli) at the first harvesting (120 days after transplantation) of chilli grown in acid sulfate soils.

Treatment	Grain yield (g/plant)					
	Badarkhali soil			Cheringa soil		
	BS <sub>10</sub>	BS <sub>20</sub>	Gw Mean	BS <sub>10</sub>	BS <sub>20</sub>	Gw Mean
<b>Gw<sub>0</sub></b>	<b>6.8 A</b>			<b>5.5 A</b>		
A <sub>20</sub>	2.8 b	9.8 a		6.6 a	3.8 b	
A <sub>30</sub>	5.6 a	7.4 b		4.6 b	7.0 a	
<b>Gw<sub>50</sub></b>	<b>6.6 A</b>			<b>5.4 A</b>		
A <sub>20</sub>	3.6 b	6.6 b		3.8 b	2.4 b	
A <sub>30</sub>	6.0 a	10.2 a		0.285.6 a	4.8 a	
<b>BS Mean</b>	<b>4.6 n</b>	<b>8.6 m</b>		<b>5.15 n</b>	<b>5.75 m</b>	
L.S.D. at 5% level			<b>1.20</b>			<b>0.60</b>

In a column, means followed by a common letter are not significantly different at 5% ( $p \leq 0.05$ ) level.

crop to the soils. However, for a cost benefit analysis of these treatments in relation to the acid neutralization capacity with time and frequency of liming under laboratory and field conditions, further studies on different soils under variable climatic conditions should be carried out. The present findings suggest that the studied fallow land of acid sulfate soils could be brought into productive land after several times flash leaching of the crashed soil of about A<sub>30</sub> sizes in order of quick reduction of the salinity and acidity problems. Leaching followed by the use of basic slag or material rich in basic cations in the soil is a pre-requisite.

**ACKNOWLEDGEMENTS:** The study was carried out under the financial and technical support (1998-2005) of the Volkswagen (Ref: 1/73 802, dated 03-08-98) and the Alexander von Humboldt (AvH) foundations, respectively. We are also grateful to the DAAD for providing two Sandwich Scholarships for the Ph D program of SM Kabir and MMA Bhuiyan.

#### REFERENCES

- Elawad, S.H. and Green, Jr., V.E. (1979): Silicon and the rice plant environment: A review of recent research. *IL. Riso*, **28**, pp. 235-253.
- Gashcho, G.J. (1977): Silicon status of Florida sugarcane. *Soil Crop Sci. Soc. Fla. Proc.*, **36**, pp. 188-191.
- Kabir, S.M. (2005): Acid sulfate soil ecosystems and their sustainable management. Unpublished Ph D Thesis submitted to the Dept. of Soil, Water and Environment, University of Dhaka, Dhaka 1000, Bangladesh.
- Khan, H.R., Bhuiyan, M.M.A., Kabir, S.M., Blume, H.-P., Oki, Y., and Adachi, T. (2007): Consequences of basic slag on soil pH, calcium and magnesium status in acid sulfate soils under various water contents. *Journal of Biological Sciences*, **7**, pp. 896-903.
- Khan, H.R., Bhuiyan, M.M.A., Kabir, S.M., Oki, Y., and Adachi, T. (2006): Effects of selected treatments on the production of rice in acid sulfate soils in a simulation study. *Jpn. J. Trop. Agr.*, **50**(3), pp. 109-115.
- Khan, H.R. (2000): Problem, prospects and future directions of acid sulfate soils. *Proc. Inter. Conference on Remade Lands 2000*, Brion, A. and Bell, R.W. (ed.). pp. 66-67. Nov. 30 to Dec. 2, 2000, Perth, Australia.

Khan, H.R. and Adachi, T. (1999): Effects of selected natural factors on soil pH and element dynamics studied in columns of pyretic sediments. *Soil Science and Plant Nutrition*, **45**, pp. 783-793.

Khan, H.R., Rahman, S., Hussain, M.S., and Blume, H.-P. (1996): Response of rice to basic slag, lime and leaching in two saline-acid sulfate soils in pot experiments. *Z. Pflanzenernahr. Bodenk. (J. Plant Nutr. Soil Sci.)*, **159**, pp. 549-555.

Khan, H.R., Rahman, S., Hussain, M.S., and Adachi, T. (1994): Growth and yield response of rice to selected amendments in an acid sulfate soil. *Soil Science and Plant Nutrition*, **40**, pp. 231-242.

Klute, A. ed. (1986): Methods of Soil Analysis. Agron. Series 9. Am. Soc. Agron., Publ. Madison, WI, USA.

Soil Survey Staff, (1999): Soil Taxonomy. A basic system of soil classification for making and interpreting soil surveys. 2<sup>nd</sup> Edition. NRCS-USDA. Agr. Handbook No. 436. Washington DC, USA.

Van Mensvoort, M.E.F. and Dent, D.L. (1998): Acid sulfate soils: Methods for assessment of soil degradation. *Advances in Soil Science*. Lal, R. et al. (ed.). CRC press LLC, Boca Raton, Flo., pp. 301-335.

Zaman, S.M.H., Rahman, K., Howlader, M. (1982): Simple lessons from biometry. Publ. No. 54, Bangladesh Rice Research Institute, Gazipur, Bangladesh.