

## Photo-Thermal Solar Energy Conversion Device

Uhuegbu, Chidi C

Department of Physics, Covenant University, Ota. Ogun State. Nigeria

---

### Abstract

Photo-thermal solar energy device was constructed using local available materials for producing hot water for house hold uses. The motivation for this research is to find an alternative source of power for this purpose, since we have epileptic supply of conventional power in the country. It was observed that intensity of solar radiation varies with time and the temperature of water produced depended on the amount of solar radiation and the time of the day as observed from the graphs plotted. We obtained boiling water at 100 degrees Celsius with the device at Covenant University, Ota, Ogun State. Nigeria.

---

Keywords: solar energy, photo-thermal, conversion, temperature

---

### INTRODUCTION

Increased energy requirements to maintain the present level of growth of modern civilization combined with rapid depletion of the ozone layer by the conventional sources of energy like oil, coal, natural gas, etc have prompted scientists all over the world to research and develop efficient and economically feasible devices to extract energy from non-conventional sources like the sun.

The efficiency of conversion of solar energy into heat is mainly determined by the optical properties of the absorber surface. An efficient selective surface for photo-thermal conversion should have high absorption over the spectral range of solar spectrum (0.3-2.5 $\mu\text{m}$ ) combined with low thermal losses because of the re-radiation at longer wavelengths. The wavelength cut off between these two ranges depends on the condition of solar flux concentration and operating temperature (Choudhury et al. 1982, Babatunde, 1985, Gaer et al. 1955, Hollands, 1971, Winston, 1974).

Furthermore, if a solar absorber coating is to be adopted for wide spread use, it must be resistant to mechanical and optical deterioration and have a long operational life. For successful commercial exploitation, it is necessary that these selective coating while retaining their advantages over the non-selective black paint, should be available at a cheaper cost. According to Hutchins et al., 1981, Bleom et al, 1985, Lin et al, 1977, Banerot et al. 1974 selective paints satisfy these requirement partially, while other selective absorbers like black nickel, black chrome, multi-layer tandem stacks and some other composite semiconductor surfaces, which have been investigated in the literature by Tabor, 1956, Lampert and Washburn, 1979, Driver et al. 1977, Seraphin, 1981, Gittleman et al, 1979 and Lampert, 1979 are prepared by expensive manufacturing processes.

Apart from coating selective surface for photo-thermal solar energy conversion, researchers like Aries et al, 1986 worked on high performance

selective surface such as stainless steel for the photo-thermal conversion of solar energy, the working process of stainless steel conversion coatings is of great advantage due to its reproducibility and the ease of its working method. The system at the present time allows the industrial treatment of large size collectors and with variation of the time, composition of bath and temperature conditions, it is possible to optimize the properties of the coat. The obtained collector presents excellent optical properties and good resistance to corrosive atmospheric agents.

A good absorber surface for photo-thermal energy conversion possesses the following characteristics:

- Spectral selectivity
- Stability at the operating temperature,
- Long life time and
- Economy of large scale fabrication.

The last requirement is a consequence of the relatively low density of the solar flux at the earth's surface which in turn means that the solar energy must be intercepted over large areas.

The thermal and mechanical stability requirements of any absorber surface are determined by the particular application and operating environment. Three general temperature ranges have been identified. The first covers temperature from ambient to 100°C and including such applications as space heating, hot water heating, distillation and drying. The temperatures in the range of approximately 100°C to 250°C are applicable to air conditioning, refrigeration and process heating. Finally, high temperature applications at temperatures above 250°C include power generation and high grade heat for chemical processing (Hahn and Seraption 1978). It has been observed that in any viable absorber, any mechanism, whether it is diffusion, chemical and photochemical reactions; recrystallization, phase angles, scattering, etc; which leads to an alteration of the optical constants of the absorber must be effectively suppressed. These stringent requirements restrict many of the traditional thin film materials and

approaches, thereby leading to an increased emphasis on material science and film deposition.

All materials used for photo-thermal energy conversion must possess a good absorptance  $\alpha$  (close to 1.0) in the solar range (0.3-2.0 $\mu\text{m}$ ) and low thermal emissivity  $\varepsilon$  (close to zero) in the infrared i.e. for  $\lambda > 2\mu\text{m}$ . In addition to the above, it must have a feature shown below.

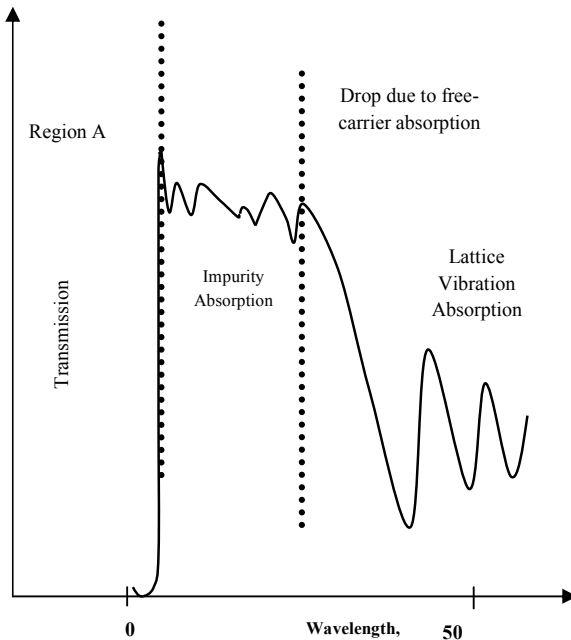

Fig 1.0 Transmission as a Function of Wavelength  
Source: (Seraphin et al 1976)

According to Seraphin et al (1976), starting from short wavelengths, a region of strong absorption is first encountered, caused by interband transition of electrons. The oscillator strength of these continuums transition is large, leading to absorption coefficient in excess of  $10^3\text{cm}^{-1}$ . The intrinsic nature of this absorption makes it insensitive to doping within wide limits which is an advantage with respect to worsening of the performance by interfacial diffusion of impurities.

The absorption drops in an edge located roughly at the photo energy required to cross the forbidden gap. Its profile depends upon a number of parameters. Direct versus indirect character of the fundamental transition as well as the  $E(k)$  profile of valence and conduction band is known to be of importance. Final state interactions such as excitations determine the line shape of the edge. Purity and structural perfection of the materials are influence. Another requirement which such material must fulfil is a low refractive index value, possibly of a value 2 or less and this establishes the second requirement for the absorber in the tandem approach.

In this research project, I will report on the photo-thermal energy conversion of solar energy by various materials by constructing a prototype solar heater. I will also research into various utilization of solar energy in the area of thermal applications.

## THEORIES

In recent years, many researchers have worked on the phenomenon of photo-thermal energy conversion. Some of their findings are reported. Arise et al, 1986 reported high performance selective surface from stainless steel for the photo-thermal conversion of energy, and found that by varying treatment time, concentration of bath and temperature conditions, it is possible to optimize the properties of the coat. They found that the collector obtained presented excellent optical properties ( $\alpha_s = 0.96$ ) and good resistance to corrosion atmospheric agents. Furthermore, that due to the stability of the optical properties at high temperature, the employment of this material can be recommended for a collector working in vacuum.

Salau et al, 1985, on the optical properties of lead,  $\text{Pb}_x\text{K}_{1-x}$  ( $0.1 < x < 0.9$ ) thin films reported that in solar photo-thermal converters, it is desired to maximize the efficiency of the conversion system. This requires minimizing the thermal losses by surface radiation and at the same time enhancing the solar absorptivity, to this end, the optical properties of the absorbing surface in a solar collector could be tailored to have high absorptivity  $\alpha$ , (close to 1.0) in the solar range (0.3- 2.0 $\mu\text{m}$ ) and low thermal emissivity  $\varepsilon$ , (close to zero) in the infrared i.e. for  $\lambda > 2\mu\text{m}$ . Hence, the surface must offer a spectral profile properly marched to solar emission and thermal radiation properties.

Choudhury et al. 1982 reported on black cobalt selective coatings by spray pyrolysis for photo-thermal conversion of solar energy. In their work, on a single step process of spray pyrolysis for growth of black cobalt selective surfaces on commercial aluminium and galvanized iron substrates, they found that the material has a good absorption up to 220°C temperature of operation with the optimized stable films displaying selective properties and good adhesion to the substrates. They can be grown by spraying mixtures of cobaltous nitrate and thiourea mixed in the ratio of 1:1:33 on the substrates maintained at 150°C.

Heric, 1985 reported the solar thermal energy devices, which are devices that convert sunlight energy into heat. For solar thermal energy conversion to be possible the device or converter has a key component which is the collector. The collector essentially has two main components- the absorber plate which converts sunlight into heat and the transparent cover which reduces convective and radiative heat losses from the absorber. He reported

several types of solar energy thermal converters using gas or liquid as a working fluid.

Lof, 1981 reported on various types of solar collectors which can be of any geometry but the tubular one is the most common type. Figures 2 – 5 show various types of these collectors. According to Lof, 1981 evacuated tube collectors involved tubular designs which have lighter strength to withstand external pressure. Some of the designs involve flat absorbers inside the tubes and other employ cylindrical absorbing surfaces. This collector is made up of five types shown in figure 2 (A-E). In the United States type, Fig 2 (A) the absorber is a thin, blackened flat metal sheet supported across the diameter of a single evacuated glass tube, with pipe connections for liquid circulation sealed into one end of the tube. The liquid circulates through the pipe which is in close thermal contact with the absorber plate. A copper plate with selective black coating suppresses thermal radiation so that all forms of heat loss are small at ordinary space heating temperatures. In this type of collectors operation at temperatures close to 300°F is possible at satisfactory efficiency.

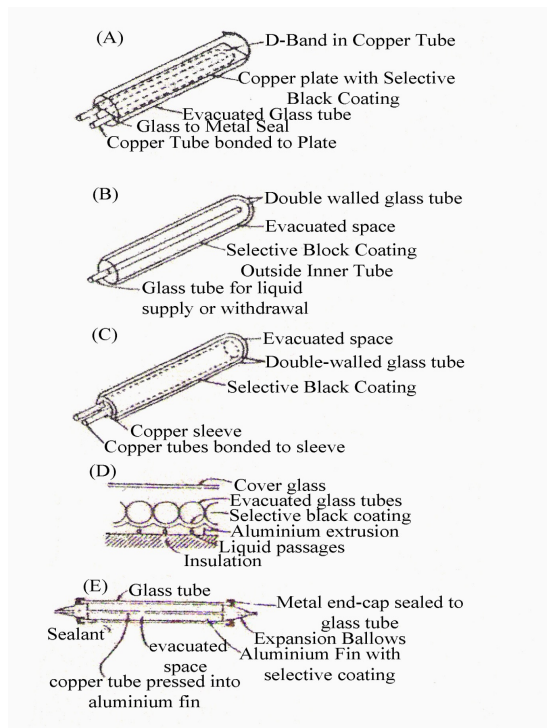

Fig 2. Types of Evacuated Tube collectors

Source: (Lof, 1981)

In figure 2 (b) the convectional “vacuum bottle” principle is used. This consists of a double glass wall with an evacuated space between liquid is circulated through the interior of the inside tube. The energy which is absorbed by the selective black coating

outside ends of individual tubes are inserted into insulated manifolds which provide the proper fluid flow pattern through tube multiples. Figure 2 (C) also has a double-walled tube with a vacuum between the two glass surfaces. The inner glass tube of this type of collector is black-coated and contains a thin cylindrical copper “sleeve” in which a copper pipe in the form of a long, narrow U is attached. The circulation of liquid is done through the copper pipe in series flow with adjacent tubes.

Figure 2 (D) consists of an experimental evacuated tube collector comprising an aluminium heat transfer surface, with internal liquid passages tightly fitting a closely packed array of evacuated glass tubes which are internally coated with a selective black absorber. For weather protection, a flat cover is used.

The fifth type of evacuated collector involves the direct flow of the liquid in a small copper pipe bounded to a flat metal absorber plate inside a single evacuated glass tube. Differences in expansion are handled by use of metal bellows bounded to the end of the glass tube and to the metal pipe. Apart from the evacuated tube collectors, other types of collectors such as flat-plate liquid solar collectors, air-heating collectors, solar air heaters with internal manifold two collectors in series and flat-plate air solar collectors as shown (Figs 2-5).

A special concentrator known as Fresnel collectors using panels of lenses to focus solar rays onto a collector had also been reported by Hasting et al, 1974. Several authors, amongst them Tabor, 1958, Rankine and Charters, 1969, Maduge, 1984, Moukebe et al. 1984, Kettle, 1960, Leiber, et al. 1962 and Balaga, 1978 have dealt with specific problems in heat transfer characteristic of collectors. Others have looked at practical problems, for example dirt on indication and use of plastics in collector construction Garg, 1974 and Close et al, 1978. In general, attention has been focused on two major areas;

- Type and number of transparent cover plates, and
- Material and geometry of the absorber plate (selective or non-selective). But the common goals are the reduction of heat losses and improvement of heat transfer from the collector to the carrier fluid.

In an attempt to improve the performance of a flat plate collector, Lof, 1981 investigated experimentally a solar collector, which consisted of a sheet metal through about 0.0762 meters deep, 0.6096 meters wide and 1.2192 meters long, containing glass plates arranged in stair-step fashion and separated by 0.00635 meters space (figures 3 and 5). Each glass pane was partly blackened with black paint and arranged so that each black surface was beneath two clear surfaces. One or more cover glasses were used to form a nearly air-tight enclosure containing the overlapped plates. By means of this arrangement

solar energy is transmitted through the transparent surface and winter conditions with ordinary glass, the trough with one cover plate showed the highest efficiency.

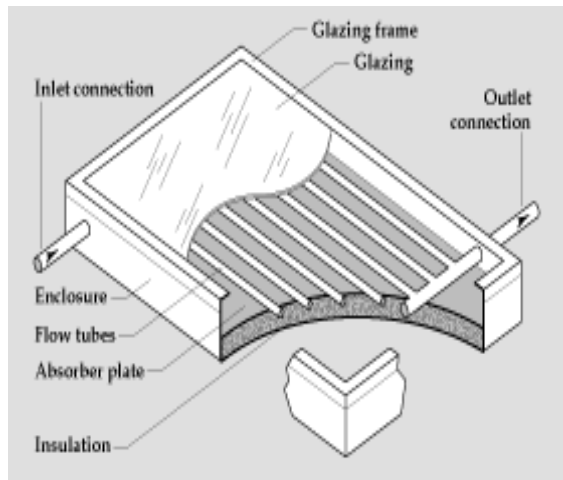

Fig 3 Flat plate liquid solar collector

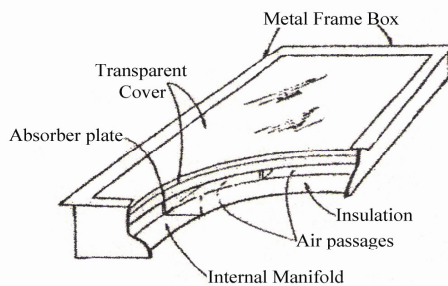

Fig 2.3 Typical Air-Heating Collector

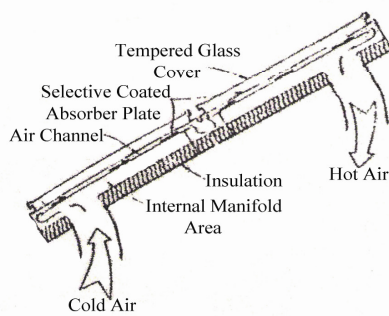

Fig 2.4 Solar Air Heater with internal manifold two collectors in series

**EXPERIMENT**

A prototype solar heater box was designed and constructed using metal sheet. Two holes were drilled at the top of the metal box which is the outlet and one near the bottom which is the inlet. The metal box was

painted black to enhance the absorption and retention of heat. The copper tube was run from the inlet to the outlet. The collector plate which was painted black also was placed flat on the copper tub. This set up was placed inside a wooden box to prevent heat loss to the environment. A pane of glass was placed on the top to focus sun rays on the heater and trap all the infrared radiation. Cold tap water was allowed to flow through the inlet and hot water was collected at the outlet. The temperatures of the cold water, hot water, time and intensity of the sun were measured and recorded.

**RESULT AND DISCUSSION**

Graphs of temperatures verses intensity, temperature verses time and intensity verses time were plotted. From the graphs, it was observed that the intensity of the sunlight, temperature of the heater increased with the time of the day before decreasing towards the evening. When the intensity of the sunlight was highest, the temperature of the hot water was highest. The panel absorbs the infrared rays from the sun which is converted to heat that the cold water absorbed to produce hot water. It was observed that this process can only take place when there is enough sunshine. In our case, we got boiling water when there was no cloudy and rainy day.

**CONCLUSION**

We have successfully designed and constructed a photo-thermal solar energy conversion device using local materials which was used to obtain boiling water.

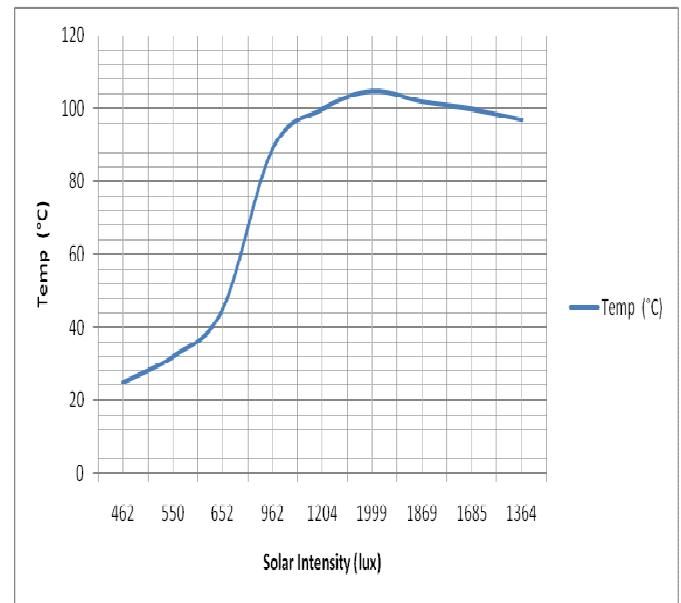

Fig. 6 Graph of Temperature against Solar Intensity

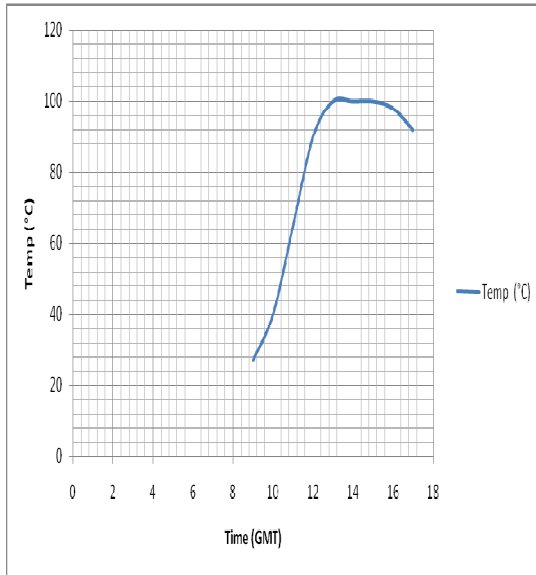

Fig.7 Graph of Temperature against Time

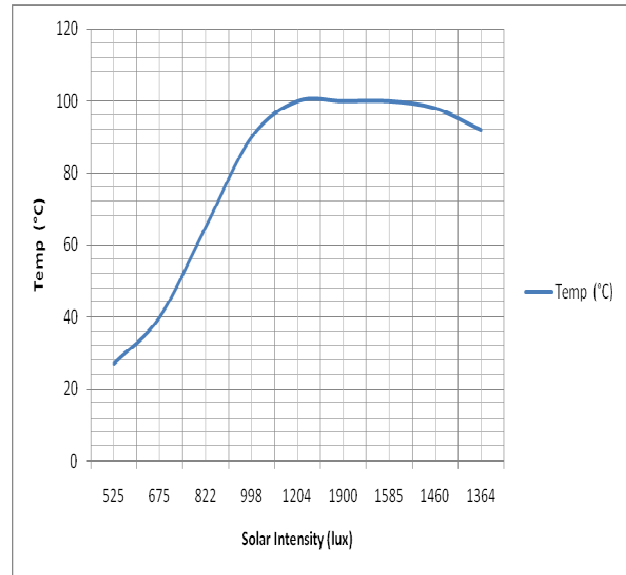

Fig 9 Graph of Temperature against Solar Intensity

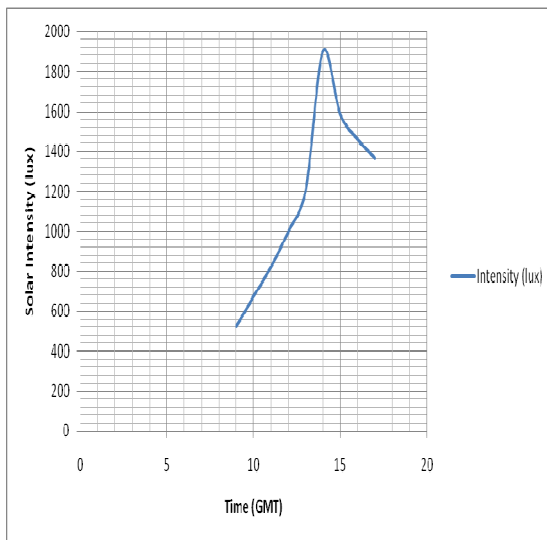

Fig. 8 Graph of Solar Intensity against Time

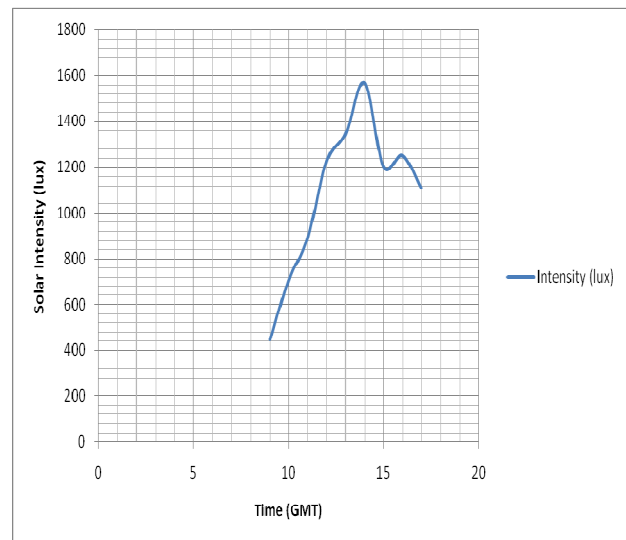

Fig.10 Graph of Solar Intensity against Time

## REFERENCES

- Aries, L, Bizard, Y, Fraysse, D and Traverse, J. P (1986): solar energy, 36, Pp. 521-529-42.
- Babatude, E. B (1985): African Union of Physics proceedings of the Workshop on the Physics and Technology of Solar Energy Conversion Pp. 31-42.
- Banerot, R. B and Howell, J. R (1974): Sharing the sun solar technology, loc.cit Pp.111-124.
- Balaga, A. (1978): Solar Energy 21, Pp.331-338.
- Bloem, H, De Grijis, J. C and De Vaan, R. L. C (1985): Solar Energy in the Eighties vol.1, loc.cit Pp.176-180.
- Choudhury and Sehghah, H. K (1982): Solar Energy 28, No. 1, Pp.25-31.
- Close, D. J and Yusoff, M. B (1978): Solar Energy 20, Pp.459-463.
- Driver, P. M, Mc Cann, M, Berger, J, Persson, I.L and Swanson, J.E (1977): Solar Energy 19, Pp.301.
- Eation, C. B and Blum, H. A (1975): Solar Energy 17, Pp.151-158.
- Garg, H. P (1974): Solar Energy 15, Pp.299-302.

- Gaer, J. T and Dunkle, R. V (1955): Trans. Conference on the use of Solar Energy vol.2, part 1, Section A, Pp 41.
- Gittleman, J.I, Gompper, M. E and Watters, M. (1979): Solar Energy Materials 1, Pp.93.
- Hahn, R.E, and Seraphin, B.O. (1978): Physics of thin films vol. 10, 3. Pp.59
- Hastings, L.T, Allums, S.L and Cosby, R.M (1974): Sharing the sun solar technology, loc.cit. Pp. 275-290.
- Herich, Othieno (1985): African Union of Physics Proceedings of Workshop on the Physics and Technology of Solar Energy Conversion Pp. 127-133.
- Hollands, K.G.T. (1971): Solar Energy 17, Pp.151.
- Hutchins, M.G, Hayward, K. and Kenna, J.P. (1981): Solar Technology in the Eighties, 1, Pergamon press Oxford Pp.136-140.
- Kittle, C. (1966): Introduction to Solid State Physics, John Wiley and sons.inc New York 6<sup>th</sup> Edition. Chapter 8 Pp. 203-242.
- Lampert, C.M, and Washburn (1979): Solar Energy Materials 1, Pp. 81.
- Lampert, C.M. (1979): The use of Coating for Enhances of Solar Thermal Energy Collection 1, 11:L.B.L-8072 Reprint (1979).
- Leibert, C.H and Hibbard, R.R (1962): Solar Energy 6, Pp.84.
- Lin, R.H and Zimmer, P.B (1977): Honeywell Rep. Coo-2930-12, Minnepicopolis.
- Lof, G.O.G. (1981): Space Heating with Solar Energy loc.cit Pp.72-83.
- Lof, G.O.G. (1981): Solar Collectors, Second International Symposium on Non-Conventional Energy I.C.T.P and I.C.A.P. Catania Pp 1-31.
- Maduge, B.O. (1984): B.Sc Project Report at the Department of Mechanical Engineering University of Ife now Obafemi Awolowo University Ile-Ife.
- Moukebe, I.S and Okolo, P.I. (1984): Low Cost Solar Collectors for Developing Countries. Paper Presented at the 7<sup>th</sup> Annual Conference of the Nigeria Institute of Physics.
- Rankine, A.D and Charters, W.W.S. (1969): Solar Energy 12, Pp.517-523.
- Salau, A.M, Kuku, T.A and Akinnifesi, J.O (1985): African Union of Physics and Technology of Solar Energy Conversion pp. Pp.109-123.
- Seraphin, B.O and Meinel, A.B. (1976): Optical Properties of Solids. New Developments. North-Holland and Publishing Company 1976. Chapter 17, Pp. 927-970.
- Seraphin, B.O. (1981): Material Science Aspect of Photo-thermal Solar Energy Conversion. Second International Symposium on Non-Conventional Energy I.C.T.P and Catania Pp. 1-56.
- Tabor, H. (1956): Bulletin of Research Council of Israel, 5a, Pp.119.
- Tabor, H. (1958): Bulletin of Research Council of Israel, 6c, Pp.155-176.
- Winston, R. (1974): Solar Energy 16, Pp.89-96.