



PROPOSAL OF FINAL PROJECT

TITLE:

Project of Rocket Payload and Launcher EZ RX-100

SUBTITLE:

Design and Development of a Flight and Intelligent Robotic-based Rocket Payload System with Two Degrees of Freedom of Control for X-Y Cartesian Navigation Landing System

PREPARED BY:

Zulfikar Artha
NRP. 7506040013

MAIN SUPERVISOR:

Dr. Ir. Endra Pitowarno, M.Eng
NIP. 196206301987011001

C.O SUPERVISOR:

Nu Rhahida Arini, ST, MT
NIP. 1308108

**ELECTRONICS ENGINEERING POLYTECHNIC INSTITUTE OF
SURABAYA
INSTITUT TEKNOLOGI SEPULUH NOPEMBER
SURABAYA
2009**

APPROVAL SHEET

1. **Title** : Design and Development of a Flight and Intelligent Robotic-based Rocket Payload System with Two Degrees of Freedom of Control for X-Y Cartesian Navigation Landing System
2. **Name** : Zulfikar Artha
NRP : 7506040013
Program of Study : Mechatronics Engineering
University : Electronics Engineering Polytechnic Institute of Surabaya-ITS
3. **Main Supervisor** : Dr. Ir. Endra Pitowarno, M.Eng
NIP : 196206301987011001
4. **C.O Supervisor** : Nu Rhahida Arini, ST, MT
NIP : 1308108

Approve,

Main Supervisor

(Dr. Ir. Endra Pitowarno, M.Eng)

NIP. 196206301987011001

C.O Supervisor

(Nu Rhahida Arini, ST, MT)

NIP. 1308108

Approve,

The Head of The Engineering
Program of Study Mechatronics

(Dr. Ir. Endra Pitowarno, M.Eng)

NIP. 196206301987011001

Surabaya, 22 -07-2009

Student

(Zulfikar Artha)

NRP. 7506040013

to know

Coordinator of Final Project

(Nu Rhahida Arini, ST, MT)

NIP. 1308108

CONTENTS

CHAPTER 1	1
1 Introduction	1
1.1 Rocket Palyload System	1
1.1.1 Telemetry	1
1.1.2 Satellite Navigation System	2
1.1.3 Digital Compass / Digital Compass	2
1.1.4 Radio Frequency	3
1.1.5 Remote Control	4
1.2 Statement of The Problem	5
1.3 Research Question	5
1.4 Hypothesis	5
1.5 Purpose of The Study	5
1.6 Importance of The Study	6
1.7 Scope of The Study	6
1.8 Outputs Expected From The Project	6
CHAPTER 2	7
2.1 GPS (Global Positioning System)	7
2.2 Receiver GPS	7
2.3 Interface Serial RS-232C	8
2.4 Remote Control	9
2.5 DC Motor	9
2.6 Navigation Landing Ssystem	9
2.7 Kinematic Movement	12
2.8 Diagram Block Control	13
CHAPTER 3	14
3.1 Research Procedure	14
3.2 Research Design Variable	14
3.3 Research Strategy	15
3.4 Work Schedule	16
REFERENCES	17

CHAPTER I

INTRODUCTION

In this study, reviewed, designed and made the rocket payload with give a flight system and intelligent robotic-based. Previously, rocket payload only has a parachute to make a rocket payload fly in the air while the direction movement driven by wind. Then made the development of rocket payload. in development of rocket payload given the intelligent Robotic to rocket payload. Given intelligent to rocket payload that can direct themselves to the position launched early. In fulfillment of this final project is made a rocket payload that can set the position of landing. Based on the above, the system made the determination of the location of rocket payload-based GPS (Global Positioning System) by utilizing RF transceiver ER400TRS as data communication with a PC and made on the actuator system to the rocket payload so the rocket payload can be directed to the desired position (still in control of the remote control). In this system, Microcontroller will retrieve data from the GPS coordinates for the position of the form and sent to the PC through RF transmitter-receiver. Data received by the RF receiver is sent to the PC. After the PC to get data from the RF receiver that is the form of position coordinates, then according to the database that has been built, PC will determine the areas in which the rocket payload and are displayed in the form of a map (map location).

1.1 Rocket Payload System

1.1.1 Telemetry

Telemetry is the process of measuring a parameter object (objects, space, natural condition), which results in measurement send to other places through the process of data both with and without using cables using cable (wireless), the next data to be used directly or needs to analyzed. In general telemetry system consists of six parts, namely supporting the object measuring, sensor, transmitter, transmission channel, and the recipient of the view / display. (Rovianto Muhamad, Rahmat Basuki, Rizal Achmad. 2005).

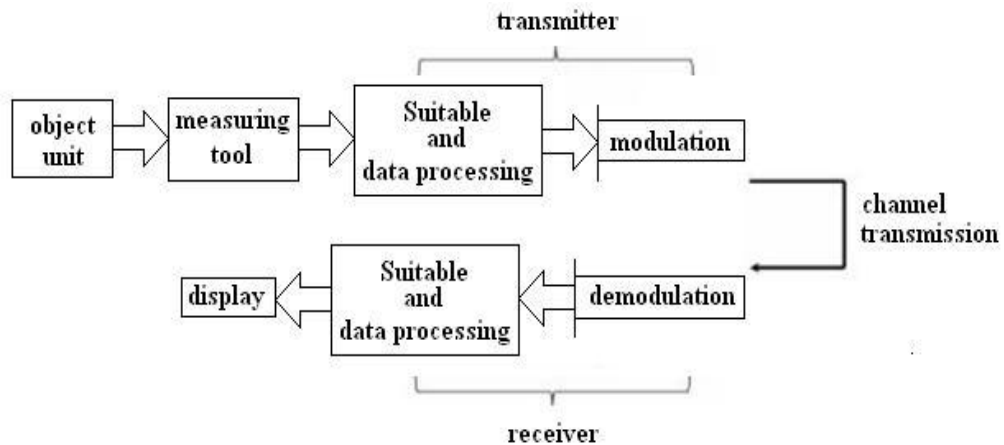

Figure 1: Telemetry system

1.1.2 Satellite Navigation System

Satellite navigation system is a system used to determine the position of the Earth, using the satellite. Navigation satellite system to send position data (longitude and latitude, and altitude) and time signals from satellites, to the recipient in the tool surface. On the surface of the recipient can know the position, and the right time. In the year 2007, the satellite navigation system that works only NAVSTAR Global Positioning System (GPS) the United States. GLONASS, Russian satellite navigation systems are currently in the stage of improvement, and is estimated to be completed in 2010. The EU is being launched in the new satellite navigation system called Galileo is scheduled to finish in the year 2013. Satellite navigation system that is being developed is owned Beidou China and India made IRNSS.

1.1.3 Digital Compass / Magnetic Compass

Compass module is designed specifically for the robotic field for robot navigation. This compass uses two sensors magnetic fields KMZ51 Philips made sensitive enough to detect the earth's magnetic fields. Two sensors installed this mutual crossed. On the compass module has been installed and a circuit of conditioning signal and microcontroller. So that we can access the current compass degrees position directly (Soebakti Hendawan 2008).

Pins connection on the compass module

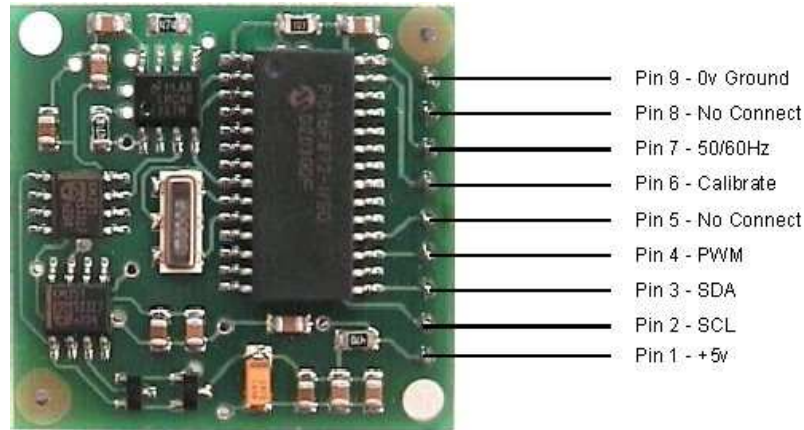

Figure 2: Magnetic Compass

Pin 2 and 3 are used to communicate with the protocol (language) I2C to take the compass position.

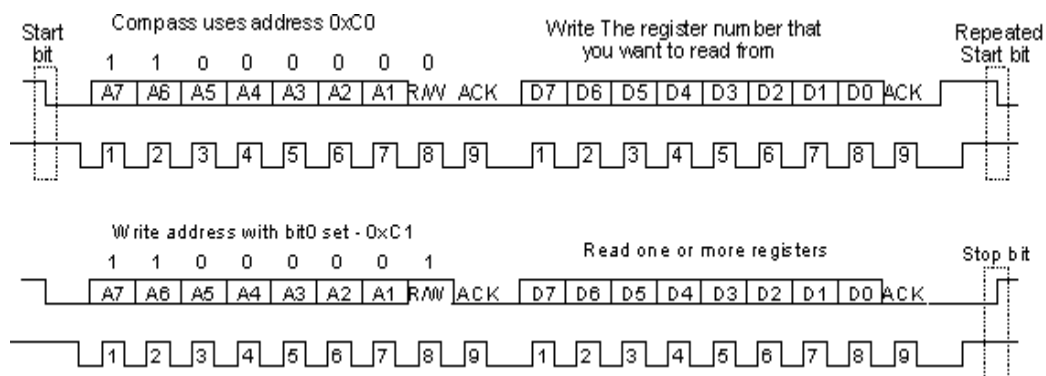

Figure 3: I2C Protocol

1.1.4 Radio Frequency

The Easy-Radio 400 Transceiver is a complete sub-system that combines a high performance low power RF transceiver, a ‘flash’ programmable microcontroller and a voltage regulator. The microcontroller programmes the functions of the RF transceiver and provides the interface to the host system via a serial input/output. It also contains programmable EEPROM memory that holds configuration data for the various transceiver operating modes. The microcontroller also relieves the host from the intensive demands of searching for signals within the noise, recovering the received data and transmitting data in a suitable format. A Received Signal Strength Indicator output can be optionally used to measure received signal levels. The module connects to a 50 Ohm antenna such as a whip, helical or PCB loop.

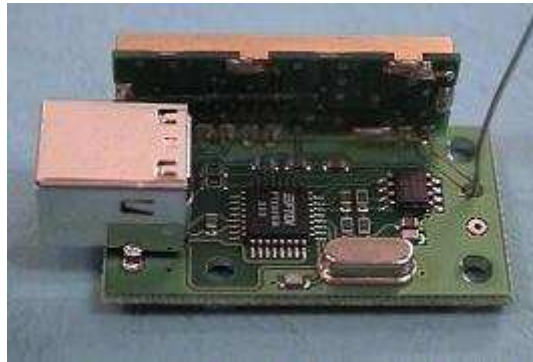

Figure 4: Radio Frequency Blok Diagram

The Serial Data Input and Serial Data Output operate at programmable standard Baud Rates (default/typical 19,200Baud) and the two handshake lines provide optional flow control to and from the host. The Easy-Radio Transceiver can accept and transmit up to 128 bytes of data which it buffers internally before transmitting in an efficient over-air code format. Any other Easy-Radio Transceiver within range that ‘hears’ the transmission will decode the message and place the recovered data within a receive buffer that can then be unloaded to the receiving host for processing and interpretation.

1.1.5 Remote Control

Remote control is a tool that can be used to control a system of long distance. In general, the remote control is used to give commands to the distance from the television or electronic goods such as stereo systems and DVD players. Remote control devices for this form of objects, usually small wireless hand held in a suite with a button to adjust the various settings, such as television channel, track number, and volume. In fact, on most modern peranti with a control like this, the remote control has all the control functions while the device that is itself only has a little control of the main fundamental.

1.2 STATEMENT OF THE PROBLEM

1. In a rocket payload needed GPS to know position of rocket payload so that it can be watched from the distance.

2. A rocket payload can move freely without too tied to the direction of the wind and then added actuator on the right hand side on the left rocket payload.
3. Therefore, the need to apply the robotic system on the rocket payload so the direction of movement of the rocket payload can be controlled.

1.3 RESEARCH QUESTIONS

1. How to display the GPS coordinates of the position in the PC and displayed in the form of a map of the location?
2. How do create a mechanical model of the rocket payload and movement of the rocket payload simulation after there actuator?
3. How to control the movement of rocket payload using remote control?

1.4 HYPOTHESIS

1. The rocket payload can move freely with using actuator on the right side of the left without bound closely with the wind.
2. Success in the delivery of data from the GPS position in the PC which is then displayed in the form of a map of the location.

1.5 PURPOSE OF THE STUDY

1. To design a rocket payload to be able to set the direction movement by adding a actuator on the right and left.
2. To develop a flight system and intelligent robotic-based system on the rocket payload with adding actuator.
3. To display the position data from GPS to a PC and displayed in the form of a map of the location.

1.6 IMPORTANCE OF THE STUDY

1. There are telemetry system on the rocket payload that contains many sensors that are relatively expensive, so it is important that the rocket payload given navigation so the rocket payload that can be found and used again.
2. To find out how to work the GPS for navigation and communication between the tools to know who controlled. Therefore, it is important also to increase and develop their knowledge.

1.7 SCOPE OF THE STUDY

- 1.** Studying literature.
- 2.** Studies on the principle of work and the use of GPS.
- 3.** Studies of serial communication without using a cable but using remote control.
- 4.** Design and development of the rocket payload included: the PC-based interfacing, and interfacing GPS and control the rocket payload using programming in C language or visual basic.

1.8 OUTPUTS EXPECTED FROM THE PROJECT

- 1.** The rocket payload can be controlled using the remote control.
- 2.** Data position from the rocket payload can received the PC through the GPS to displayed to a location in the map.
- 3.** Publications.

CHAPTER II

LITERATURE REVIEW

a. GPS (*Global Positioning System*)

GPS (Global Positioning System) is a system that is able to give a precise location in the earth, at any time, in any condition and anywhere. The principle of GPS is the measurement of distance (range) between the GPS Receiver to the satellite. Satellites also provide location information when the orbit where the satellite is located above the surface of the earth. GPS can work like this, when we know our exact distance from the satellites in the sky, then we can assume that we are at a point on a surface with a radius equal to the imaginary satellite radius. When we know the exact distance us from the two satellites can be assumed that we are at a point in the region deduction between these two satellites. If we do that, This is the third to give two results that make sense where our actual location. GPS Receiver has a mathematical method to calculate and eliminate locations that do not make sense.

b. Receiver GPS

The main components of the GPS receiver antenna is common with pre-amplifier, that function to receive signals that emanated from the satellites GPS and send back to the Radio Frequency. The RF (Radio Frequency) signal with the identifier, and signal processing. Microprocessor, which is a component of the entire control system operating activities. Data processing (navigation solution), precision oscillator, share resources, and the display unit, memory, and data recorder, which is used to record all data received.

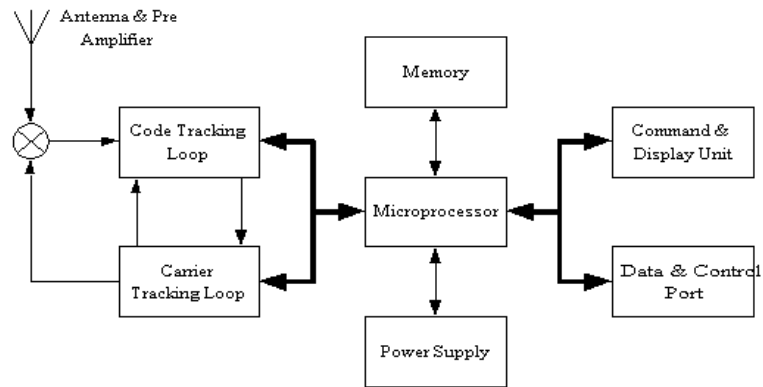

Figure 5: Configuration of *Receiver GPS*

c. **Interface Serial RS-232-C**

Serial communication is used is RS-232-C, which is a set of tools that act as the interface in the process of data transfer between computers or between computer and external device associated with it in the form of serial communication. RS232 signal transmission system using a voltage level with respect to system common (power ground). Good for this type of communication data in one by one. RS232 port on the PC only for a single device. Sending data is done in each bit. Speed data transfer must be the same between the sender and the recipient, if not the same happen overflow (Ibnu Budir 2007).

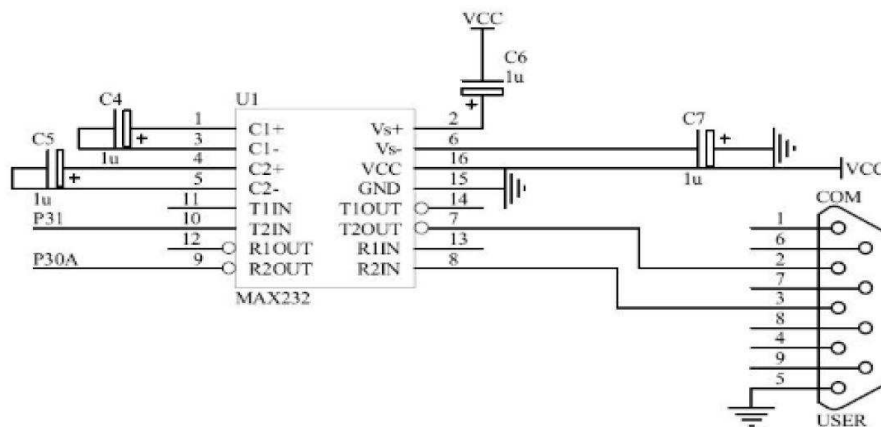

Figure 6: Wiring Diagram RS232 to Microcontroller

d. **Remote Control**

Remote control is a tool that can be used to control a system of long distance. In general, the remote control is used to give commands to the distance from the television or electronic goods such as stereo systems and DVD players. Remote control devices for this form of objects, usually small wireless hand held in a suite with a button to adjust the various settings, such as television channel, track number, and volume. In fact, on most modern peranti with a control like this, the remote control has all the control functions while the device that is itself only has a little control of the main fundamental.



Figure 7: Remote Control

e. **DC Motor**

Motor that is used to direction rocket payload is a DC motor. DC motor installed with propeller to push the rocket payload to the front, right and left.



Figure 8: Motor DC and Propeller

f. **Navigation Landing System**

Navigation controls have important components, namely GPS and Compass. GPS (Global Positioning System) is used to determine the location of an object while Compass is useful to indicate the direction of the object's side. 2 component is related in the navigation control and can not be separated. To find out where the position and direction of a side thing must go through the process. The process will be described in general in the block diagram below.



Figure 9: General of The Navigation Control scheme

While the navigation controls that are used on the final project of this 2 ways. 2 way is.

1. Self-Running Mode
2. Remote Control Mode

Self-Running Mode

Self-Running Mode is automatically control navigation. That mean is the rocket payload will direction itself to return to the initial position at the time he launched with the help microcontroller. The process of how work on the Self-Running mode will be explained through the block diagram below.

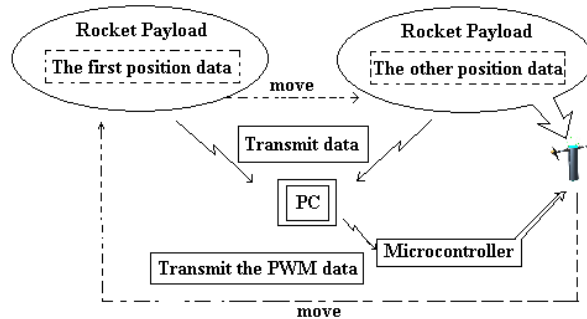

Figure 10: Self-Running Mode

Explanation:

1. Previously launch, microcontroller circuit activated to send the position data from GPS and the Compass data at the first position to PC.
2. Then the rocket payload launched so that the rocket payload residing to the position (x). At the position (x), the position data from GPS and the Compass data for the position (x) sent to a PC. So a PC will show to display.

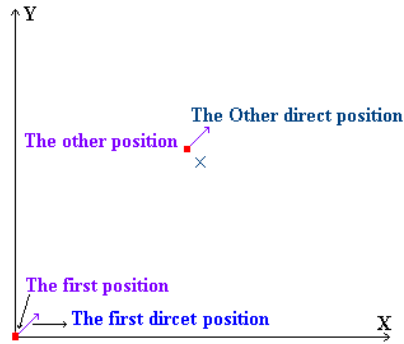

Figure11: Display of a Point Movement

3. From different point of position that displayed to a PC can know direct and movement of the rocket payload. Then PC sending data in the form of speed control of DC motor to microcontroller.

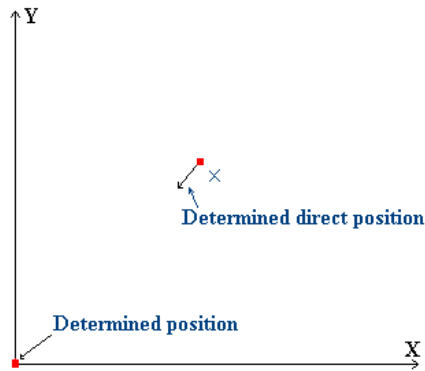

Figure 12: Display of Determined position

4. Data in the form of speed control of DC motor that sent by microcontroller will processed and output of microcontroller is different of rotation motor that causing the rocket payload move to position and direct that determined previously.
5. The rocket payload will move to position that determined and will take care themselves to the first position.

Remote Control Mode

Remote Control Mode is the navigation controls manually. This mode is used when the rocket payload will not be able to control itself caused by the wind blowing very fast. Following block diagram of the Remote Control mode.

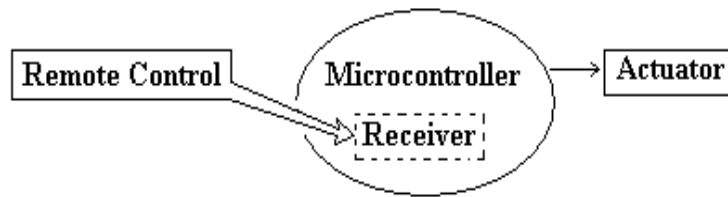

Figure 13: Remote Control Mode

g. Kinematic Movement

Movement launch of the rocket payload if seen from up to down projected into 2D projection (x and y). Movement from one point to other point causing different distance of the first position and the next position. If movement of the rocket payload will projected to 2D becoming at the under picture.

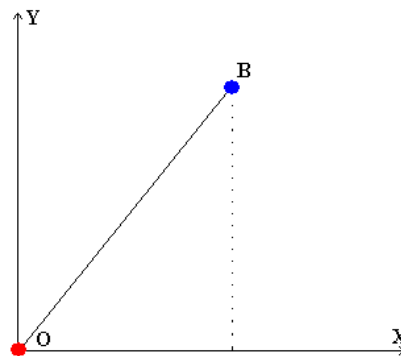

Figure 14: Projection 2D

The rocket payload move from the first point O to the end point B. For knowing speed from the point O to B so can using formulation as following.

$$V = \frac{X_B - X_O}{t_B - t_O} \dots\dots\dots [1]$$

h. Diagram Block Control

Input of the rocket payload is position data from GPS and compass data from Digital Compass but for control direct of the rocket payload using speed control of DC motor. This is diagram block control as following.

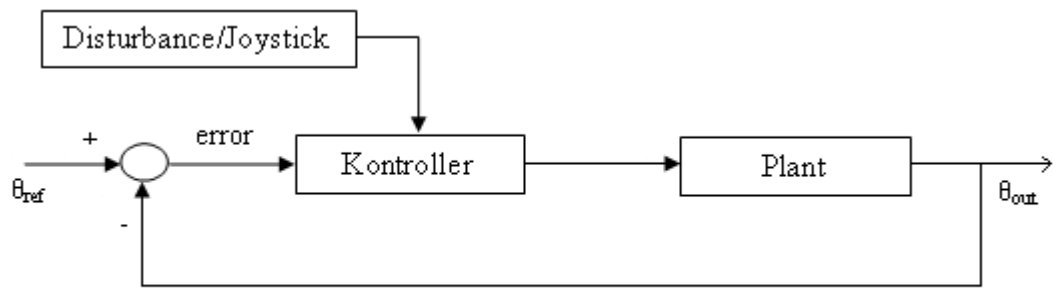

Figure 15: Diagram Blok Control

CHAPTER III

RESEARCH METHODOLOGY

a. RESEARCH PROCEDURE

1. Learn about motor control using a serial communication
2. Learning the form of general rocket payload and develop it with system actuator.
3. Learning the connection between a PC with GPS using the RF transmitter-receiver.
4. Test motor cycles using serial communication from the PC.
5. Test the rocket payload flights.
6. Test in the case of GPS position data to a PC through RF transmitter-receiver.
7. Design full the rocket payload (microcontroller, GPS receiver, and RF transmitter-receiver) into one package.
8. Conducting experiments on the rocket payload. Analyzing the results, discuss and compare that with the hypothesis.
9. Write thesis.

b. RESEARCH DESIGN VARIABLE

Robot Parameters

1. Robot rocket payload
2. Rocket payload mass
3. Motor mass
4. Dimension of parachute

Communication Parameters

1. Receiver GPS
2. RF transmitter-receiver
3. interface PC
4. Remote control

Display Parameters

1. Display from Visual Basic
2. Location Map

c. RESEARCH STRATEGY

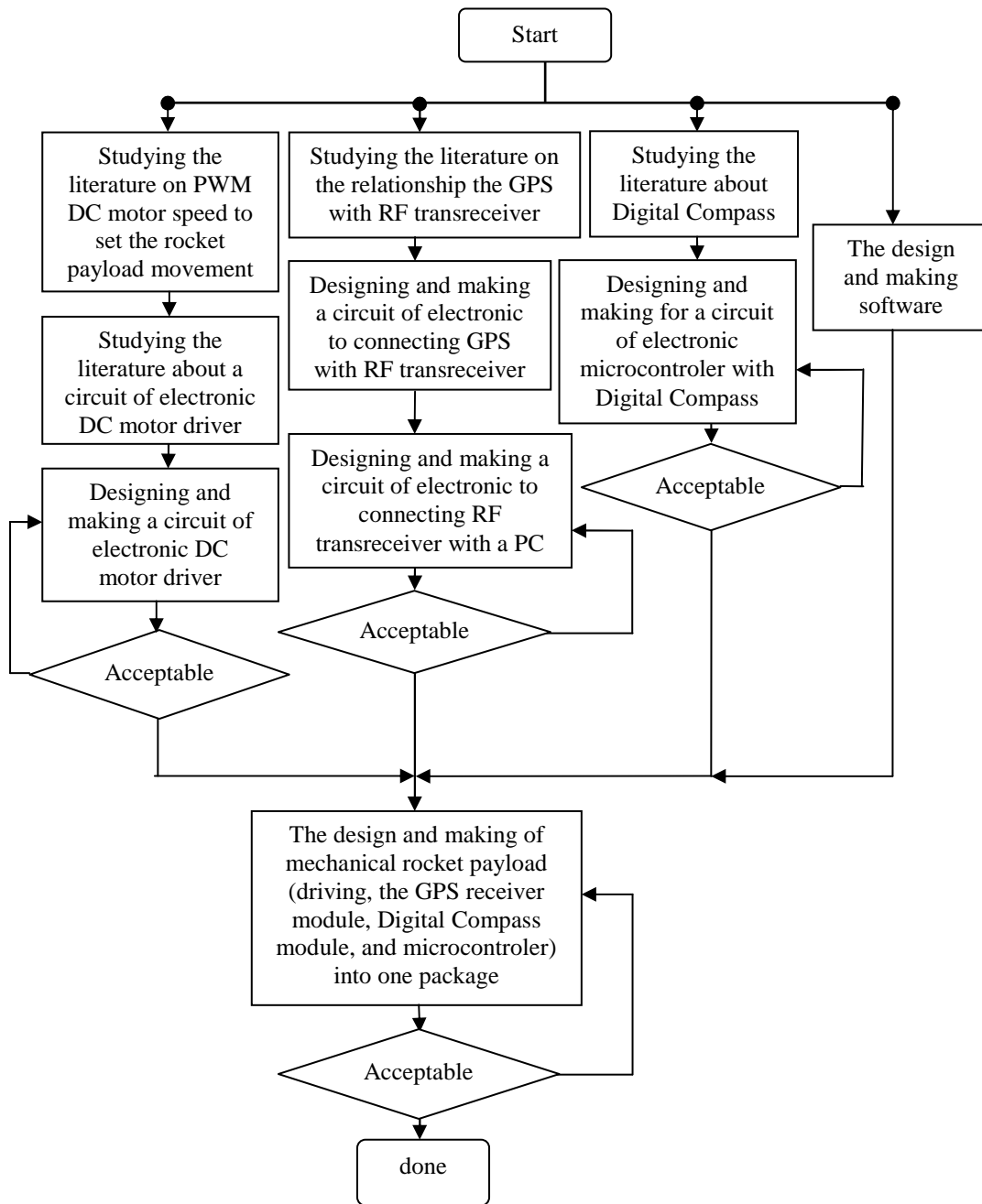

d. WORK SCHEDULE

No.	Job/Target Descriptions	Month (xx) & Year (20xx)												
		07	08	09	10	11	12	01	02	03	04	05	06	07
		09	09	09	09	09	09	00	00	00	00	00	00	00
1	Literature review studies	■	■	■	■	■	■							
2	Designing and making a circuit of electronic DC motor driver		■	■	■	■								
3	Designing and making a circuit of electronic to connecting GPS with RF Transreceiver				■	■	■							
4	Designing and making a circuit of electronic to connecting RF Transreceiver with a PC				■	■	■							
5	Designing and making for a circuit of electronic microcontroller with Digital Compass				■	■	■							
6	The design and making software		■	■	■	■	■							
7	The design and making of mechanical rocket payload (driving, the GPS receiver, Digital Compass module, and microcontroller) into one package								■	■	■	■		
8	Experimental Studies								■	■	■	■		
9	Thesis Writing										■	■		
12	Submit Thesis											■	■	

REFERENCES

- Adil Irdam. (2000). “Konsep Manajemen Lalu Lintas Kapal Pada Alur Pelayaran dan Pelabuhan Menggunakan GPS dan Sistem Informasi Laut”, Jurnal Survering dan Geodesi, Indonesia.
- Budir, Ibnu. (2007). “Komunikasi Serial Mikrokontroler dengan PC”, Artikel Pembelajaran Mikrokontroler MCS-51”, Indonesia.
- Effendi Luqmanul Hakim, Martinius Syafri. (2005). “Pemanfaatan Teknik Modulasi (PWM) Untuk Kompensasi Seri Terkendali”, SMED (Seminar Mesin Elektrik dan Elektronika Daya), Politeknik Malang.
- Harsono Nonot, Subhan Ahmad, Sukaridhoto Sritrusta, dan Sudarsono Amang. (2006). “Teknik Pemetaan Wilayah Secara Cepat dan Akurat Menggunakan GPS yang Dikoordinasikan Melalui Jaringan 3G Atau yang Setara”, Prosiding Konferensi Nasional Teknologi Informasi dan Komunikasi untuk Indonesia, ITB-Bandung.
- Herijanto Frenki, Widyantara Helmy. (2008). “Mobile Monitoring System Using Global Positioning System (GPS) Based On Radio Frequency”, Gematek Jurnal Teknik Komputer Volume 10 Nomor 1, STIKOM Surabaya.
- Ma'ruf Bilal, Djawahir, Sunantyo, A., Parseno, Widjadjanti, N., Yulaikhah, Nasihun, M., Armeinus, F., dan Zaim, M. (2001). “ Pengadaan Jaring Kontrol Deformasi dengan Menggunakan GPS di Kawasan Candi Borobudur”, Jurnal Survering dan Geodesi, Indonesia.
- Rovianto Muhamad, Rahmat Basuki, Rizal Achmad. (2005). “ Desain dan Realisasi Sistem TelemetriFSK”, T. Elektro- STTTelkom
- Setyadji Bambang. (2006). “Pemanfaatan *Global Positioning System* (GPS) Dalam Pembangunan Informasi Spasial”, Pertemuan Ilmiah Tahunan III- T.Geomatika-ITS, Surabaya, Indonesia.
- Zamora Ramon, Sadli Rahmad, dan Yunidar. (2005). “Sistem Pengendalian Motor Stepper Tanpa Kabel Berbasis Mikrokontroler AT89C51”, Jurnal Rekayasa Elektrik, Banda Aceh, Indonesia.
- Soebakti Hendawan. (2008). “Digital Compass”.
- [http://azies-tech.com/cara_mengontrol_kompas_CPMS03_dengan_cara_PWM_dan_I2C\(12\).htm](http://azies-tech.com/cara_mengontrol_kompas_CPMS03_dengan_cara_PWM_dan_I2C(12).htm)
- <http://www.ftdichip.com/FTProduct.htm>
- <http://gedex.web.id/archives/2008/05/18/interfacing-antara-avr-dengan-cmps03/>
- <http://www.ristinet.com/index.php?ch=8&lang=&s=56f978dd735e6d72f38514a392562142&n=247>

<http://www.total.or.id/info.php?kk=Remote%20control>

<http://id.wikipedia.org/wiki/Navigasi>

http://id.wikipedia.org/wiki/Pengendali_jarak_jauh

http://id.wikipedia.org/wiki/Sistem_navigasi_satelit