

Lupiáñez, José Luis; Molina, Marta; Flores, Pablo; Segovia, Isidoro (2007). *Mathematics primary teacher training in the context of the european higher education area*. The International Journal of Interdisciplinary Social Sciences, 2(4), pp. 223-231

Abstract

The future implementation of the European Higher Education Area requires thorough reflection on how to design and develop teacher training courses. In this reflection, it is important to reconsider, among other issues, (a) the role of prospective teachers in their own learning process and (b) the professional competencies that they must develop in the course of their higher education. Since 2003, the University of Granada has undertaken the development of pilot experiences to adapt some degree programs to this new framework. One of these degrees is Teacher in Primary Education degree, which includes several courses that focus on promoting prospective teachers' development of mathematical and pedagogical knowledge. In this paper how to organize future teachers' learning through practical activities in one of these courses is described. Firstly, the general process of adapting the course is analysed. Secondly, its theoretical and practical structure, with some examples of practical activities, are described. Finally, some results of the implementation are discussed.

Keywords

European Higher Education Area; Teachers Training; Competencies; Mathematics Education; Theory and Practice.

This paper describes an innovative experience in the effort to adapt mathematics training for prospective Primary School Teachers to the new directives proposed by the EHEA within the current legal framework in Spain. First, we analyse the elements that characterize future degrees within this new framework. We then describe the adaptation process and the results obtained for the specific case of training in Mathematics Education for prospective Teachers of Primary Education carried out as a pilot experience in the Department of Mathematics Education at the University of Granada.

1. PARAMETERS OF CHANGE TOWARD THE EHEA

In the academic year 2004-05, the first courses in some of the degree programs at the University of Granada underwent changes motivated by the imminent implementation of the European Higher Education Area (EHEA). One of these programs was that of Teacher with a Specialization in Primary Education from the Faculty of Education Sciences at the University of Granada.

The ultimate goal of the EHEA is to have universities adopt a system of degrees that will be comprehensible and comparable in all European Union countries by 2010. Some of the directives established have been given concrete form in Spain in laws governing the development of the future degrees. One of these is the so-called "European credit" or ECTS (European Credit Transfer

System) credit, which involves a change in the way of measuring student workload. Another consists of characterizing each degree in terms of the general and professional competences that define the degree-holder's professional profile. These two directives require a substantial change in teaching activity. They focus on the student and conceive the professor's role as that of guide and advisor to ensure that the student acquires the established competences.

In embracing these directives, the Andalusian Regional Government has promoted experimentation with current university degrees to draw conclusions from the experience that will enable the design of new degrees in accord with the EHEA.

To develop this experience, fourteen degrees were chosen, among them the Degree of Teacher with Specialization in Primary Education. The following guidelines were established:

- To reduce lecture time in the course and promote seminars and directed activities.
- To promote the development of the competences established in the Tuning Project (González and Wagenaar, 2003), competences common to all of the degrees, as well as the specific professional competences that each degree establishes.
- To consider the student's and not the professor's work as the element that characterizes the courses.
- To calculate the adaptations of ECTS credits such that 1 hour of theoretical class requires 1.5 hours of student study, while 1 hour of practical classes requires 0.75 hours of study.
- To adapt the course programs to all of the above-mentioned elements, stressing the **objectives** in the form of competences, selecting **contents** that focus on developing these competences, planning the methodology oriented to the student's learning, giving more importance to tutorials, and designing the **evaluation** in accord with the other components of the curriculum.

2. THE TRAINING OF THE MATHEMATICS PRIMARY TEACHER FROM THE PERSPECTIVE OF MATHEMATICS EDUCATION.

From the perspective of Mathematics Education, we undertake the training of the future teacher of Primary Education in one 9-credit core course, *Mathematics and its Pedagogy* (4.5 theoretical and 4.5 practical credits), and one 4.5-credit compulsory course at the University of Granada, *The Mathematics Curriculum in Primary Education* (2 theoretical and 2.5 practical credits). The students can complete their training by choosing between several elective courses, one of them devoted to Problem-Solving.

The core first-year course mentioned above is designed to ground our students' mathematical knowledge. It aims to deepen the mathematics skills that they developed during their required secondary schooling before introducing certain

new concepts in Mathematics Education. The term we use to designate this option has been: *Mathematics for teachers*. With this title, we hope to emphasize that:

- The contents are mathematical, involving the concepts and procedures, their representations, phenomenology, modelling and history (Rico, 1997).
- The scope of these concepts and their area of formalization, application, signification, representation and study correspond to those a Primary Education teacher should have.
- Mathematics is presented from a cultural, social and epistemological perspective consistent with the current official curricula for this education level.

The required course indicated for the second year seeks to professionalize the future teacher in his or her role as math educator and thus requires that he or she have mastered certain concepts in Mathematics Education. These concepts are always channelled to facilitate the comprehension of the curriculum, as well as the design, implementation and evaluation of the teaching of Mathematics in Primary Education.

2.1 The pilot experience in the “Mathematics and its Pedagogy” course

This section will focus on our experience in the course “Mathematics and its Pedagogy,” in which we began experimentation with European credits during the academic year 2004-2005 and which has been the focus of greatest reflection and attention in the Department’s teaching seminars.

In confronting this course, we found it important not only to adapt the program numerically to the ECTS and redefine the objectives to adapt them to competences but also to establish a precise differentiation between theoretical and practical credits.

Diverse variables permit us to distinguish theory and practice. Ferrater (1991, p. 2652, 2661) shows us different ways to understand these variables, both in training processes in general and in teacher training. We can group these differences into two blocks, the first corresponding to the epistemological separation between theoretical and practice knowledge, the second to the competences and thus the way of teaching.

We consider that the division between the *theoretical and practical credits* in the courses is based on the actions performed during teaching and the competences that the students are to acquire. One way of viewing the practical credits in this context is to focus on tasks in which the theoretical concepts are applied *to solve problems in the professional world* (professional practices, such as class planning, the design and qualification of exams, etc.) *or in the everyday world* (mathematical practices for solving problems, analysing phenomena, interpreting information, etc.). Another perspective leads us to see that work for the practical credits must tackle *procedural competences* tied to know-how, such as those related to the use of technological means for teaching (professional practice) or the use of mathematical procedures (mathematical practice) (Monereo, 1994, Pozo and Monereo, 1999).

Finally, but not unrelated to the foregoing aspects, another differentiation between theory and practice can be made based on the degree to which the student acquires a *leading role* in the performance of tasks. This idea enables us to consider as *practical activities* those in which the student *acts*. The idea of practice would thus be tied not to the content encountered but to the way this content is related to knowledge. A theoretical, conceptual content can even be considered in a practical way if we give the student a leading role in performing activities that enable him or her to interpret it, debate it with classmates, share it with others, present it, and contrast it with texts in which it is defined, characterized, exemplified, etc. Thus, we understand practice, like Resnick and Ford (1990), as exercise.

In the organization of the course, we have adopted this last criterion to distinguish the practical credits. The teaching has been organized by differentiating the theoretical classes from the practical classes according to the kind of action undertaken by the teacher and the students, not by the content proposed. This criterion agrees more closely with some of the basic ideas for change under debate, which are directed to emphasizing that the student assume a greater role in his or her learning.

As to the organization of the student workload of 4.5 theoretical credits and 4.5 practical credits, the teaching load for the course involves 3 hours a week throughout the academic year, divided into one session of two hours and another of one hour with the following time organization:

- Theoretical credits:
 - Two hours of class a week for 21-weeks of the academic year
 - Orientation seminar of one hour a week for 21 weeks
 - Individualized tutorials during the professor's office hours throughout the year.
- Practical credits:

Practical action seminars for the students for three hours in the course of nine weeks, three weeks at the end of each trimester (in December, March, and June).

2.2 Development of the theoretical credits

In the theoretical class sessions, the teaching responsibility is the professor's. The professor is to provide material so that the students can undertake study of the course in a significant way, without this involving the presentation of all contents and results that the student must learn. To achieve this, the professor performs tasks like those the students are expected to perform, making explicit the actions involved; the students observe in order to construct a conceptual model of these tasks (*modelling*) or the teacher carries out part of the task and encourages the students to perform other parts with the professor's help (*scaffolding*, Vizcarro, Liébana, Hernández, Juárez and Izquierdo, 1999).

These teaching processes consider the contents holistically (Moral, 2001), leaving the specific parts for the students to perform with the support of the recommended documents. This method seeks to produce deep learning of the

concepts covered by developing them with growing complexity and diversity and global abilities (Vizcarro et al., 1999). During the development of the theoretical contents, the practices of contextualization, application and evaluation are performed (Díaz-Godino, 2005) through the methods of instruction indicated.

The orientation seminars take place every week for an hour. In these sessions, the students must express their needs, questions, etc. The exercises requested by the students are also performed; exercises related to those developed previously by the professors and inspired by the questions that will later be used in the evaluation tests (see Appendix). To this end, students are encouraged to perform the proposed tasks, from the interpretation of the data to the search for necessary information, while the professor provides the information requested (*training*). In other cases, the students choose the tasks to resolve and demonstrate their abilities, reasoning and interpretation of the concepts employed in solving them (*articulation*).

Finally, the tutorials provide individualized attention in the professor's office, resolving difficulties that the students encounter with the topics covered in the course and the tasks required of them. During these tutorials, the instruction provided is based on training, scaffolding, modelling and reflection.

In order to direct the action, we have developed some work guides and activity sheets that orient the student and guide the professor's work in class (see example in First Topic of the program in the Appendix). The students perform the assigned tasks, working in groups or individually, participate in presentations, and develop their work and present the work developed using the appropriate technological media.

2.3 Development of the practical credits

In the practical class sessions, the students are the ones who perform the tasks that the professor has planned. The kind of practice in these classes is based on problems of exercitation, application and evaluation (Díaz-Godino, 2005); or experiences, illustrative experiments, practical exercises and research (Caamaño, 2003). All of these include activities of observation, prediction, critique, generation and analysis (Llinares, 1998). The work model proposed covers reading the guide document, carrying out group work with the material provided, presenting results and developing a team workbook. In the course of the class, we perform the following models of instruction:

- **Training:** The student performs the tasks, while the professor observes this performance and gives advice and help.
- **Articulation:** The students resolve tasks, demonstrating their reasoning and abilities.
- **Reflection:** The students compare their processes for solving problems with those of their classmates, first through group work and then by means of performing presentations.
- **Exploration:** The students develop new situations to which to apply the concepts learned. In designing the tasks they propose, they are encouraged to find new situations affected by the concepts learned.

Practical activities, in which the students act on concrete material under the professor's supervision, are also stimulated. To achieve this, the students are divided into three subgroups for their practical classes. These groups rotate through three different weekly scenarios: the classroom (mathematics workshop), the math laboratory (manipulative materials) and the computer lab.

In each subgroup, the students work in teams of four, remaining in the same small group for the whole academic year. Likewise, the same professor who directs the practice activity in each of the scenarios supervises the three blocks of content for which they perform the practical classes in that scenario. We have planned tutorials directed to the teams to be distributed throughout the course, such that each team has at least one tutorial with one of the professors for the practical tutorials.

The work in practical credits requires the students to act, first as individuals and then as a team. The professor presents the activities, responds to questions, encourages the students in their work, and coordinates the presentations. This requires the use of "practical workbook guides" (Flores and Segovia, 2004) with the relevant instructions and activities that we will now present and illustrate with examples.

2.4 Practical workbook guides

The workbooks for the practical sessions are designed to foster autonomous work in future teachers, while also constituting one of the indicators for evaluation of their performance.

There are individual and team workbooks, classified into three blocks of content (Arithmetic, Geometry and Measurement-Statistics) and into three practical scenarios (Mathematics Workshop, Manipulative Materials, and Computers) for a total of 18 workbooks. Each student has an individual workbook, which includes the explanations, activities, resources and documented sources to enable the student to tackle each of the practical exercises. The team workbook unifies the work performed individually and includes additional reflection activities on the earlier individual work.

To illustrate the contents and structure of the practical workbooks, we now present some examples. Since each consists of an initial presentation followed by its development, we will describe the presentations of three workbooks with different content and scenarios.

Arithmetic Block. Practical Workbook for working in the Computers lab.

Exercise 1: The Divisor Game

1. Introduction

In this exercise, you will work with natural numbers and the main arithmetical operations. Specifically, we will study the divisors of a number, which are all the divisors of this number except that number itself.

The study of problems of divisibility is of great importance, since they constitute the solution to a wide number of problems in everyday life, such as calculating the dimensions of a piece of rectangular cloth to make a curtain,

distributing a class of students in rows, or distributing the prizes in a contest according to the position in which the participants have placed.

2. Objectives

The main objective of this exercise is to work on the following notions through an interactive computer program:

- *Divisibility*
- *Divisors of a number*
- *Decomposition into its factors*
- *Prime numbers and composite numbers*

By performing the different activities that we propose, you will become familiar with the main properties of divisibility among natural numbers; you will be able to express one number as a product of factors, and we will approach the study of prime numbers. We will also work on the notions of perfect numbers and see how some of these ideas were studied at a certain point in ancient history.

General description of the exercise

In this activity, we introduce an interactive game for two people. The game is available on the web page <http://illuminations.nctm.org/ActivityDetail.aspx?ID=12>. The program puts the main ideas of the exercise into practice, while also developing capacities related to problem-solving, such as exploring winning strategies. The exercise begins with some games for the future teachers, to be played with each other or against the computer, so that they can evaluate the merit of starting the game or being second, the best options for beginning the game, and how the first natural numbers can be classified according to their divisors.

Geometry Block. Exercise Workbook for Manipulative Materials. Exercise 2: The Book of Mirrors
--

1. Presentation

One of the most intuitive materials for teaching geometry is the MIRROR, both for ease of use as a familiar object and for the value of analysing the relation between a figure and its image reflected in the mirror. But the mirror is also valuable because it gives rise to a “reflection,” that is, to a “symmetry.” When we apply the mirror to a three-dimensional figure, we obtain a symmetrical image of the figure with respect to the plane of the mirror. If we place it perpendicular to the plane in which a flat figure is found, we obtain the symmetry of the figure with respect to the straight line with which the mirror intersects the plane. The mirror also permits us to obtain the reflection in the plane.

Further, the mirror allows us to discover regularities in the figures. This circumstance is enriched when, instead of having a single mirror, we have a book of mirrors—that is, two mirrors, preferably rectangular, connected by one of their sides. Two mirrors forming one book enable us to obtain the composition of two symmetries with respect to planes if we do this in space, or the composition of the symmetries with respect to axes if we do it in the plane.

2. Objectives

This exercise should familiarize you with the mirror as a teaching resource and daily tool, serving to study some geometrical properties and constructions related to the reflections or symmetries.

We will thus attempt to:

- a) Obtain the figures that are produced by applying a mirror to a given figure and justify them mathematically.*
- b) Place the mirrors in such a way as to obtain specific figures.*
- c) Anticipate what will happen when we place the book of mirrors in specific positions with respect to certain figures.*

General description of the exercise

The exercise tackles different problems related to the search for and analysis of mathematical properties through the use of mirrors. We hope, on the one hand, that the future teachers will locate the axes of symmetry of the figures and, on the other, that they will construct the symmetry of a given figure. The following is a sample task in which one must find the axes of symmetry of each of the following figures and draw a segment to indicate them:

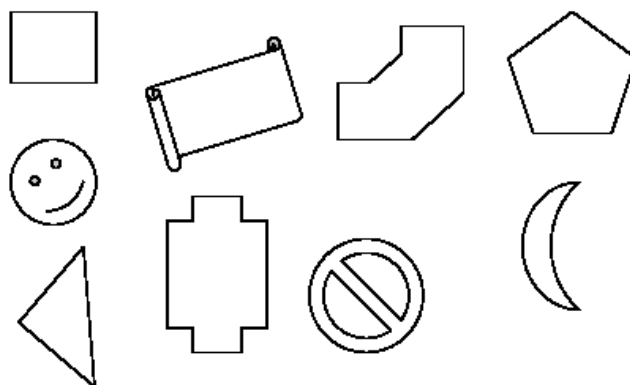

Measurement and Statistics Block. Exercise Notebook for the Mathematics Workshop. Exercise 3: Estimating measurements
--

B.1 Estimation of quantities

Make the following estimates individually (do not modify them, even if they do not agree with or differ greatly from those of your classmates)

- L) Estimate the length of the professor's desk*
- S) Estimate the surface area of the blackboard*
- C) Estimate the interior volume or capacity of the waste basket*
- P) Estimate the weight/mass of the chair on which you are sitting*

Present your results and how you performed the estimation (strategies and references used) to the classmates in your (small) group.

B.2. Study of the estimations made by the whole class

a) Record the different results from the whole class: **L**) Desk (length): **S**) Blackboard (surface area): **V**) Waste basket (volume): **W**) Chair (weight):

The group is going to perform the statistical study of all of the class results from the estimation of one of the four magnitudes studied: **Length**, **Surface area**, **Volume** or **Weight**. To select the estimation, you must do the following:

- Think of the first letter of your name.
- Determine the magnitude whose initial (**L**, **S**, **V**, **W**) is closest to the letter preceding the initial of your name in alphabetical order (for example, if your initial is **P**, the magnitude you should work on is **L**, since **P** is between **L** and **S**; if your initial is **B**, you should work on magnitude **W**, since **B** is between **W** and **L**, if we assume that **A** follows **Z**)

A, B, C, D, E, F, G, H, I, J, K, L, M, N, Ñ, O, P, Q, R, S, T, U, V, W, Y, Z, A, B, C, ...

- Copy the magnitudes that belong to the members of your group. You must study the magnitude that corresponds to the largest number of members (in case of a tie, draw lots)

B.3. What magnitude do you think has the greatest probability of being studied by the largest number of groups in the class? Explain the reasons.

B.4. Record the data of the magnitude chosen using the preceding procedure (**Length**, **Surface area**, **Volume**, **Weight**) and, as a group, develop a statistical study that includes a *Table of Frequencies*, a *Graphic Representation* and the calculation of the measure of central position and dispersion.

B.5. Represent the data graphically. From these results, draw some conclusions about the results obtained. What measurement represents the estimations? What degree of dispersion does the data show? Was the class's estimation homogeneous? Was the team's?

General description of the exercise

This exercise aims to estimate measurements of quantities of magnitudes present in the classroom. To contrast them, students must perform a statistical study of the estimations of the entire group. At the same time, students should perform a probabilistic study, in which we hope that they will examine the expected sample space and contrast it with that obtained empirically.

3. CONCLUSIONS

After the planning and experimentation in the course *Mathematics and its Pedagogy*, we not only fulfilled the guidelines for adapting the courses to the future EHEA but recognized several issues that we consider very valuable, both in our professional development as trainers involved in the project and in the development of the area of knowledge in the Faculty of Education and at the University of Granada.

First, the experience promoted interesting debates and discussions among the professors related to the planning of teacher training in the area of mathematics. These activities led us to generate classroom material agreed upon by the professors and tested by the group. Second, the actions described generated significant changes in the students' attitude toward the course *Mathematics and its Pedagogy* and to school math. Their participation in the exercises, the stimulus to autonomous work, and the fostering of communication among the students and between students and professors constitutes one of the great advances in this experience. Further, we have established a work model for classrooms with a large number of students, over 100, where it is difficult a priori to abandon a methodology based on the lecture class. Finally, the experience has been presented in diverse forums related to experimentation with the European credit (Flores, Segovia and Lupiáñez, 2006; Flores, Segovia, Lupiáñez and Molina, 2007; Lupiáñez, Segovia and Flores, 2006; Segovia, Flores, Lupiáñez and Molina, 2007). We have been invited to help other Spanish universities (Flores and Segovia, 2006), and our work has become the subject of a chapter in a book on the European convergence (Segovia, Lupiáñez and Flores, 2006).

We can thus conclude that the experience has been useful from several points of view. On the one hand, it is relevant for the training of mathematics teachers at the Primary School level, including the mathematics courses in the different specialities of the degree of teacher. It also mobilizes the organization of a university teaching initiative that promotes the student's work in massified situations. On the other hand, this is without doubt an important experience to adapting instruction to the new European directives in the material of higher education.

References

- Caamaño, A. (2003). Los trabajos prácticos en ciencias. In M.P. Jiménez, A. Caamaño, A. Oñorbe, E. Pedrinaci and A. de Pro, *Enseñar ciencias* (pp. 95-118). Barcelona: Editorial Graó.
- Díaz-Godino, J. (2005). *Aplicación de un enfoque pragmático sobre las competencias y la cognición al desarrollo curricular*. Unpublished document. Granada: Dpto. Didáctica de la Matemática.
- Ferrater, J. (1991). *Diccionario de Filosofía*. Madrid: Alianza.
- Flores, P. and Segovia, I. (Eds.) (2004). *Prácticas de matemáticas para maestros*. Granada: Dpto. Didáctica de la Matemática.
- Flores, P. and Segovia, I. (2006). Adaptación de los créditos prácticos. *Presented in the course titled Los títulos de Educación en el Marco Europeo de Educación Superior*. Salamanca: Marzo 2006.
- Flores, P., Segovia, I. Lupiáñez, J.L. and Molina, M. (2007). Innovación en la formación matemática de maestros. *Presented in Jornadas de innovación docente universitaria en el marco del EEES*. Granada: June 18-19, 2007.
- Flores, P., Segovia, I. and Lupiáñez, J.L. (2006). Matemáticas y su Didáctica en el marco del EEES. *Presented in Jornadas de Trabajo sobre Experiencias Pilotos de Implantación del Crédito Europeo en las Universidades Andaluzas*. Cádiz: September 19-21, 2006.
- González, J. and Wagenaar, R. (Eds.) (2003). *Tuning Educational Structures in Europe. Informe final fase uno*. Bilbao: Universidad de Deusto and Universidad de Groningen.
- Llinares, S. (1998). Conocimiento profesional del profesor de matemáticas y procesos de formación. *UNO, 17*, 51-65.

Lupiáñez, J.L. Segovia, I. and Flores, P. (2006). Formación Inicial de Profesores de Primaria en Matemáticas en el Marco del Espacio Europeo de Educación Superior: Implicaciones para el Aprendizaje de los Escolares. In J.I. Navarro and M. Aguilar (Eds.), *Learning Maths in childhood. Proceedings of the International Symposium on Early Mathematics* (pp. 307-328). Cádiz: Departamento de Psicología de la Universidad de Cádiz.

Monereo, C. (Coord.) (1994). *Estrategias de enseñanza y aprendizaje*. Barcelona: Graó.

Moral, C. (2001). Actividades prácticas en el aprendizaje universitario. In Moral, C. (Coord.), *Guía III Materiales de formación del profesor universitario. Proyecto andaluz de formación del profesorado universitario* (p. 303-333). Sevilla: UCUA.

Pozo, J.I. and Monereo, C. (1999). *El aprendizaje estratégico*. Madrid: Santillana.

Resnick, L.B. and Ford, W.W. (1990). Los ejercicios y de la práctica. In L. B. Resnick and W.W. Ford (Eds.), *La enseñanza de las matemáticas y sus fundamentos psicológicos* (pp. 25-57). Madrid: Paidós.

Rico, L. (Coord.) (1997). *La educación matemática en la enseñanza secundaria*. Barcelona: Horsori.

Segovia, I., Flores, P., Lupiáñez, J.L. and Molina, M. (2007). Planificación de las asignaturas de Educación Matemática para maestros en el marco del EEES. *Presented in II jornadas de Innovación docente: Innovar para el ECTS*. Granada: May 8, 15, 22 and June 1, 2007.

Segovia, I., Lupiáñez, J.L. and Flores, P. (2006). Formación práctica en educación matemática del profesor de primaria para la Europa del siglo XXI. In J.L. Benítez, J. de la Fuente, A.B. Berbén and F. Justicia, *La universidad ante el reto del espacio europeo de educación superior: investigaciones recientes* (pp. 177-208). Madrid: Editorial EOS.

Vizcarro, C., Liébana, C., Hernández, A., Juárez, E. and Izquierdo, F. (1999). Evaluación de estrategias de aprendizaje. In J.I. Pozo and C. Monereo (Coord.), *El aprendizaje estratégico. Enseñar a aprender desde el currículo* (pp. 277-299). Madrid: Aula XXI Santillana.

Appendix. Work guide for the professor and student in the first topic of the course

Mathematics and its Pedagogy

MATHEMATICS EDUCATION DEPARTMENT. UNIVERSITY OF GRANADA

Course: Mathematics and its pedagogy. Degree: Primary Teaching Education. Academic year 2004-05

Guide to Topic 1: THE NATURAL NUMBER. NUMBER SYSTEMS.

1. Uses of natural numbers (1, 123ff.).
2. Concept of natural number (1, 128ff.).
3. Ordering. The numerical sequence. (1, 131-132). Quantifying. Strategies. The zero (1, 133ff) & (2, 31).
4. Representation of the number. Number systems: antecedents and their evolution (1, 138ff) & (2, 31).
5. Place value numeric systems. Decimal Number System (1, 140) & (2, 55).
6. Materials and resources (1, 141) & (2, 163).

Bibliography

Castro, E. (Ed.) (2001). *Didáctica de la matemática en la Educación Primaria*. Síntesis: Madrid.

Gómez, B. (1988). *Numeración y cálculo*. Síntesis: Madrid.

Nortes, A. (1995). *Matemáticas y su didáctica*. Lerco Print: Madrid

Orientations for the student's work

There are three basic ideas associated with this chapter: the idea of the natural number, which is extracted from reflection on the mathematical concept, its use and its forms of representation.

Relative to this concept, we hope that the student will have an idea of the significance of the concept of number from its ordinal and cardinal conceptions. As to its use, the student should grasp the importance of understanding the numerical sequence; know the basic principles of the activity of counting and the strategies that are employed in the fundamental uses of the number: ordering and quantification. Concerning the forms of representing numbers, the student should have mastered the principles of functioning of the decimal number system as well as other forms of representation that enable reflection and analysis of it: the presence of the zero, place value, etc. Finally, the student should know the most common materials and resources in the teaching and learning of numbers and the number system, such as Cuisenaire rods, multibase blocks and the abacus. The activities that we propose below involve the questions that the student should be able to answer; we also present some examples that can serve for reflection while also illustrating whether the student understands the theoretical questions and knows how to apply them.

Activities for reflection and evaluation

- What is a number? Why is it employed (used)?
- What is counting/pairing? What kind of number results from counting/pairing? How is the number that results from counting characterized? How does one count?
- What is ordering? What kind of number results from ordering? How is the number that results from ordering characterized?
- What are the ways to represent the number? What are the characteristics of the written decimal number system? of the oral system? How is the Roman numeral system different? What other systems have the same characteristics?
- What are the particular qualities of the zero? What function does the sign of zero have in the number system?
- What materials can be used to work on the number system? How is each of these materials used?