

---

**Review**

---

## Point mutations of the *P53* gene, human hepatocellular carcinoma and aflatoxins\*

Alexander L. Gerbes and Wolfgang H. Caselmann

*Department of Medicine II, Klinikum Grosshadern, University of Munich, 81366 Munich, Germany*

(Received 29 January 1992)

---

The tumor suppressor *p53* exerts important protective functions towards DNA-damaging agents. Its inactivation by allelic deletions or point mutations within the *P53* gene as well as complex formation of wildtype *p53* with cellular or viral proteins is a common and crucial event in carcinogenesis. Mutations increase the half-life of the *p53* protein allowing the immunohistochemical detection and anti-*p53* antibody formation. Distinct *G* to *T* point mutations in codon 249 leading to a substitution of the basic amino acid arginine by the neutral amino acid serin are responsible for the altered functionality of the mutant gene product and were originally identified in 8 of 16 Chinese and 5 of 10 African HCC patients. Both groups are frequently exposed to mycotoxin contaminations of their food. Today an average *P53* gene mutation rate of 25% is assumed for high-aflatoxin B<sub>1</sub>-exposure regions. This is double the rate observed in low-aflatoxin B<sub>1</sub>-exposure countries. Although many HCC patients displaying *P53* mutations also suffer from HBV infection, which itself can lead to rearrangements of *P53* coding regions or induce the synthesis of viral proteins possibly interacting with *p53*, the specific *G* to *T* transversion within codon 249 of the *P53* gene seems to directly reflect the extent of aflatoxin B<sub>1</sub> exposure.

**Key words:** Tumor suppressor genes; Mycotoxins; Liver cancer

---

Hepatocellular carcinoma (HCC) represents one of the most common lethal tumors worldwide (1) and accounts for up to 30% of all types of malignant tumors in South East Asia and south and equatorial Africa. Chronic hepatitis B and C virus (HBV and HCV, respectively) infection, cirrhosis and aflatoxin B<sub>1</sub> exposure are considered the major aetiologic factors of HCC development (2). Molecular biological techniques have increasingly elucidated the pathogenic mechanisms which

induce or maintain malignant hepatocyte transformation, and have provided evidence that inactivation of the tumor suppressor *p53* is a common and crucial event in carcinogenesis.

### **The *P53* gene — normal and deranged functions**

The *P53* gene, located on the short arm of chromosome 17 (17p13), encodes a nuclear phosphoprotein

---

*Correspondence to:* Alexander L. Gerbes, M.D., or Wolfgang H. Caselmann, M.D., Dept. of Medicine II, Klinikum Grosshadern, University of Munich, Marchioninstr. 15, 81366 Munich, Germany.

\*This article is cordially dedicated to Professor Gustav Paumgartner, M.D. on the occasion of his 60th birthday.

which was originally identified as forming complexes with the large T(umor) antigen of the Simian Virus 40 (3). Wildtype p53 protein contains at least three functionally active domains (Fig. 1). The carboxyterminus harbours an oligomerizing function that allows p53 tetramer formation (4) and a DNA-binding activity. A transcriptional trans-activator function resides in the aminotermius (5,6), which is involved in the control of transcription by regulating the interaction of DNA polymerase-alpha with other components of the DNA replication complex (7). Whereas wildtype p53 is not required for normal ontogenic development in mice (8), it seems to exert pivotal protective functions as "guardian of the genome" (9): DNA-damaging agents like ultraviolet light, gamma-irradiation or certain chemotherapies (10) stimulate intracellular accumulation of p53. In high concentrations p53 inhibits DNA replication and cell growth thus providing sufficient time for DNA repair or allowing cytolysis, if the damage exceeds the restoring capacity of the cellular DNA repair systems (9).

Inactivation of the tumor-suppressing potential can be achieved by (1) allelic deletions or (2) point mutations within the P53 gene as well as by (3) complex formation of wildtype p53 with cellular or viral proteins (Fig. 2). Abnormal structure and expression of the P53 gene are observed in various hepatoma cell lines (11). HBV DNA integration can take place in the short arm of human chromosome 17 (12) near P53 sequences (13) and structural rearrangements and subsequent aberrant transcription of the P53 gene were found in both hepatocarcinoma cell lines and HCC tissues (14). In clonogenic assays using human fibroblast cell lines it was recently demonstrated that the disruption of one P53 gene, with the concomitant reduction of p53 protein levels, was not sufficient to induce increased endogenous gene amplification considered to represent a preneoplastic condition in this system. However, the loss of both P53 alleles in these cells resulted in an increased rate of amplifications in association with the failure to arrest growth (15).

Point mutations are present in P53 cDNAs derived from astrocytomas, breast cancers, small cell lung cancers, esophageal cancers, osteosarcomas, rhabdomyosarcomas and colon cancers (7). Germ line P53 mutations occur in families with the Li-Fraumeni syndrome with autosomal dominantly inherited risk of diverse mesenchymal and epithelial neoplasms at multiple sites (16,17). Almost 90% of these mutations are clustered in four regions of exons 5-8 of the P53 gene (18; Fig. 1). Point mutations affect distinct base pairs and result in the substitution of single amino acids. G to T transversions detected in codon 249 in human HCC (19,20) lead to a substitution of the basic amino acid

**P53**

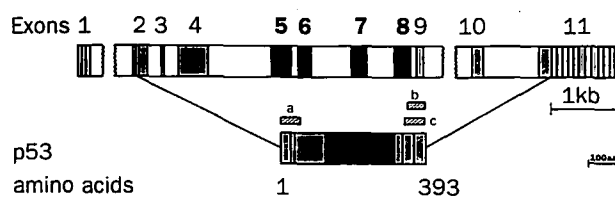

**Fig. 1.** Genomic organisation of human P53, which consists of 11 exons (numbers above) and 10 introns (white boxes). The hatched grey bars represent non-coding regions from which mRNAs are transcribed. The exons in black reflect preferred regions for point mutations. Interrupted white bars indicate a distance of 10 (intron 1) and approximately 2.5 kb (intron 10), respectively. The encoded p53 protein is given below the gene sequence. a: trans-activating domain, b: oligomerizing domain, c: DNA-binding domain of p53 protein. Size markers in kb (kilobases) and aa (aminoacids), respectively. The same pattern of coloration was chosen for corresponding exons and protein domains.

arginine by the neutral amino acid serin and may explain the functional alteration of the mutated protein. These mutations are all the more important since no mutations are observed in any other region of exons 5-8 of P53 or in non-tumorous tissues of the same patients. Furthermore, while no P53 mutations were detectable in early HCC stages as classified by histological evaluation, abnormalities of the P53 gene were shown in eight of 22 advanced HCCs (21). In six of seven cases of these advanced tumors, the P53 gene aberrations were significantly associated with the loss of heterozygosity or alteration of a second tumor suppressor gene, the retinoblastoma Rb gene (21). This emphasizes the relevance of structural P53 aberrations in advanced stages of disease and supports the hypothesis that an accumulation of mutations in tumor suppressor genes is important for tumorigenesis.

**Tumor suppressor function**

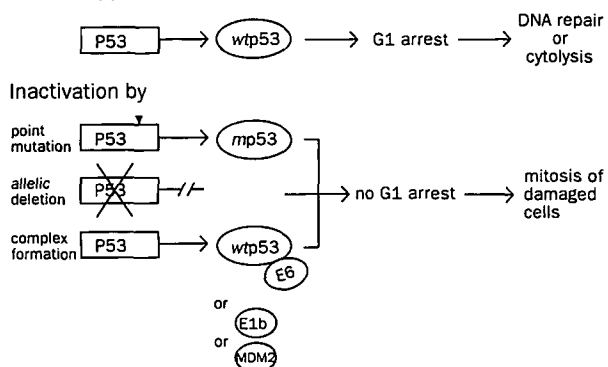

**Fig. 2.** Schematic illustration of the tumor suppressor function of wildtype p53 (wtp53). Possible modes of inactivation of p53 by point mutation (▲, mp53), allelic deletion or complex formation with viral (E6, E1b) or cellular (MDM2) proteins and the consequences for the cell cycle are depicted below.

Mutant *p53* proteins have lost the ability to act as tumor suppressors in transfection assays. While wild-type *p53* can suppress transformation in oncogene co-operation assays between *c-myc* and *c-ras*, mutated *p53* can gain transforming potential (22). Mutations increase the half life of the normal *p53* protein several times and result in the translation of a more stable protein that can be detected with immunohistochemical methods and induces anti-*p53* antibody formation in more than 25% of HCCs (23). The diagnostic efficiency of anti-*p53* antibody determination in detecting *P53* gene mutation, however, remains to be elucidated. When monoclonal anti-*p53* antibodies were used to stain tissue sections, overexpression of *P53* was shown in 9 of 58 HCC specimens (24). This indirect detection of *P53* mutations may, however, underestimate the actual frequency of gene mutations, because it will not recognize allelic deletions or codon stop introductions which lack protein translation. On the other hand, *p53* protein analysis may also overestimate the prevalence of gene mutations since other mechanisms of protein stabilization such as inactivation of *p53*-degrading enzymes or complex formation may play an important role. By forming heterologous oligomeric complexes with wildtype *p53*s mutated *p53* inactivates wildtype *p53* and antagonizes its tumor suppressing potential (25,26). The oncoproteins *E1b* and *E6* of the adeno- and papilloma viruses, respectively, are further examples for *p53* inactivating binding partners (27), which are derived from DNA tumor viruses. Recently, co-immunoprecipitation experiments identified the MDM2 protein, which was encoded and originally described on a mouse double minute chromosome but overexpressed in human sarcomas, as the first cellular binding counterpart of *p53* (28, Fig. 1). Preliminary data suggest that no *p53* mutations occur if MDM2 gene amplification is present. As with viral oncoproteins, large amounts of MDM2 protein may complex and inactivate wildtype *p53* (28).

### Aflatoxins and HCC

There seems to be a geographical correlation between *P53* codon 249 mutation in HCCs and aflatoxin B<sub>1</sub> uptake. The described point mutation was originally found in eight of 16 Chinese and five of 10 African patients (19,20) with both groups living in regions with traditionally high exposure to mycotoxins. None of these mutations were detectable in 20 patients with HCCs recently studied in Great Britain (29). Only two of 13 HCC DNAs from Germany displayed a *C* to *T* and a *T* to *A* transversion, respectively, in codons 257 or 273, but

not in codon 249 (30). In all of the latter countries the environmental aflatoxin uptake is low. More recent studies claim a *P53* gene mutation rate of 25% for high-aflatoxin B<sub>1</sub>-exposure regions (31). This is twice the rate observed in low-aflatoxin B<sub>1</sub>-exposure countries, but still considerably less than previously assumed. Data from 167 patients with HCCs from various geographic areas differing in daily mycotoxin exposure also support the notion that codon 249 mutations of the *P53* gene are directly associated with high aflatoxin uptake (32). Aflatoxin B<sub>1</sub>, the main food contaminating mycotoxin in China and Africa, is a fungal metabolite, mostly from inappropriately stored grain and is known as a hepatocarcinogen and epidemiologically defined risk factor for HCC development in different species (32,33). The involvement of aflatoxins, bioactivated by P<sub>450</sub> isoenzymes (34), in the observed *G* to *T* point mutations seems even more likely, because they specifically induce *G* by *T* substitutions by reacting almost exclusively with DNA guanines at the N7 position (35).

Since many HCC patients investigated for *p53* mutations also suffer from HBV infection, the relative impact of these factors in the development of HCC is difficult to establish. Integration of HBV DNA during infection leads to manifold rearrangements of cellular DNA that can also affect *P53* coding regions. Furthermore HBV DNA integration induces the synthesis of *HBV* transactivator proteins (36–39) which may inactivate *p53* by complex formation. However, the specific *G* to *T* point mutation within codon 249 of the *P53* gene in HCC DNAs is not pathognomonic for all HCCs but seems to directly reflect the extent of aflatoxin B<sub>1</sub> exposure.

### Acknowledgements

The research projects of ALG and WHC are supported by funds of the Deutsche Gesellschaft für Verdauungs- und Stoffwechselkrankheiten (Asche Stipendium to ALG) and a research grant of the Deutsche Forschungsgemeinschaft, Bonn (Ca 113/5-2; WHC). F. Anselm and C. Jüngst are thanked for the preparation of the manuscript.

### References

- 1 Kew MC. Tumors of the liver. In: Zakim D, Boyer TD, eds. Hepatology. Philadelphia: W.B. Saunders, 1990, 1206–40.
- 2 Colombo M. Hepatocellular carcinoma. J Hepatol 1992; 15: 225–36.
- 3 Ludlow JW, DeCaprio JA, Huang CM, Lee WH, Paucha E, Livingston DM. SV 40 large T antigen binds preferentially to an under-phosphorylated member of the retinoblastoma susceptibility gene product family. Cell 1989; 56: 57–65.

- 4 Sturzbecher HW, Brain R, Addison C, et al. A C-terminal alpha-helix plus basic region motif is the major structural determinant of *p53* tetramerization. *Oncogene* 1992; 7: 1513–23.
- 5 Fields S, Jang SJ. Presence of a potent transcription activating sequence in the *p53* protein. *Science* 1990; 249: 1046–9.
- 6 Raycroft L, Wu HY, Lozano G. Transcriptional activation by wild-type but not transforming mutants of the *P53* anti-oncogene. *Science* 1990; 249: 1049–51.
- 7 Marshall CJ. Tumor suppressor genes. *Cell* 1991; 64: 313–26.
- 8 Donehower LA, Harvey M, Slagle BL, et al. Mice deficient for *p53* are developmentally normal but susceptible to spontaneous tumors. *Nature* 1992; 356: 215–21.
- 9 Lane DP. *p53*, guardian of the genome. *Nature* 1992; 358: 15–6.
- 10 Kastan MB, Onyekwere O, Sidransky D, Vogelstein B, Craig RW. Participation of *p53* protein in the cellular response to DNA damage. *Cancer Res* 1991; 51: 6304–11.
- 11 Bressac B, Katherine M, Liang TJ, Isselbacher KJ, Wands JR, Ozturk M. Abnormal structure and expression of *P53* gene in human hepatocellular carcinoma. *Proc Natl Acad Sci USA* 1990; 87: 1973–7.
- 12 Meyer M, Wiedorn KH, Hofschneider PH, Koshy R, Caselmann WH. A chromosome 17:7 translocation is associated with a hepatitis B virus DNA integration in human hepatocellular carcinoma DNA. *Hepatology* 1992; 15: 665–71.
- 13 Slagle BL, Zhou YZ, Butel JS. Hepatitis B virus integration event in human chromosome 17 near the *P53* gene identifies the region of the chromosome commonly deleted in virus-positive hepatocellular carcinomas. *Cancer Res* 1991; 51: 49–54.
- 14 Halevy O, Michalovitz D, Oren M. Different tumor-derived *p53* mutants exhibit distinct biological activities. *Science* 1990; 250: 113–6.
- 15 Livingstone LR, White A, Sprouse J, Livanos E, Jacks T, Tlsty TD. Altered cell cycle arrest and gene amplification potential accompany loss of wild-type *p53*. *Cell* 1992; 70: 923–35.
- 16 Malkin D, Frederick PL, Louise C, et al. Germ line *P53* mutations in a familial syndrome of breast cancer, sarcomas and other neoplasms. *Science* 1990; 250: 1233–8.
- 17 Srivastava S, Zou Z, Pirolo K, Blattner W, Chang EH. Germ-line transmission of a mutated *P53* gene in a cancer-prone family with *Li-Fraumeni* syndrome. *Nature* 1990; 348: 747–9.
- 18 Nigro JM, Baker SJ, Preisinger AC, et al. Mutations in the *P53* gene occur in diverse human tumour types. *Nature* 1989; 342: 705–8.
- 19 Hsu IC, Metcalf RA, Sun T, Welsh JA, Wang NJ, Harris CC. Mutational hotspot in the *P53* gene in human hepatocellular carcinomas. *Nature* 1991; 350: 427–8.
- 20 Bressac B, Kew M, Wands J, Ozturk M. Selective G to T mutations of *P53* gene in hepatocellular carcinoma from southern Africa. *Nature* 1991; 350: 429–31.
- 21 Murakami Y, Hayashi K, Horohashi S, Sekiya T. Aberrations of the tumor suppressor *P53* and retinoblastoma genes in human hepatocellular carcinomas. *Cancer Res* 1991; 51: 5520–5.
- 22 Taylor WR, Egan SE, Mowat M, Greenberg AH, Wright JA. Evidence for synergistic interactions between *ras*, *myc* and a mutant form of *p53* in cellular transformation and tumor dissemination. *Oncogene* 1992; 7: 1383–90.
- 23 Mueller M, Volkmann M, Goeser T, et al. Anti-*p53*-Antikörper, AFP-Spiegel und Hepatitis-Status beim Hepatozellulaeren Karzinom. *Z Gastroenterol* 1993; 1: 97 (abstract).
- 24 Laurent-Puig P, Flejou JF, Fabre M, Bedossa P, Belghiti J, Gayral F, Franco D. Overexpression of *P53*: a rare event in a large series of white patients with hepatocellular carcinoma. *Hepatology* 1992; 16: 1171–5.
- 25 Jenkins J, Rudge K, Currie G. Cellular immortalization by a cDNA clone encoding the transformation-associated phosphoprotein *p53*. *Nature* 1984; 312: 651–4.
- 26 Finlay C, Hinds P, Levine AJ. The *P53* proto-oncogene can act as a suppressor of transformation. *Cell* 1989; 57: 1083–93.
- 27 Sarnow P, Ho Y, Williams J, Levine A. Adenovirus *E1b-58 kD* tumor antigen and SV 40 large tumor antigen are physically associated with the same 54 kD cellular protein in transformed cells. *Cell* 1982; 28: 387–94.
- 28 Barak Y, Oren M. Enhanced binding of a 95 kDa protein in cells undergoing *p53*-mediated growth arrest. *EMBO J* 1992; 11: 2115–21.
- 29 Challen C, Lunec J, Warren W, Collier J, Bassendine MF. Analysis of the *P53* tumor-suppressor gene in hepatocellular carcinomas from Britain. *Hepatology* 1992; 16: 1362–6.
- 30 Kress S, Jahn UR, Buchmann A, Bannasch P, Schwarz M. *P53* mutations in human hepatocellular carcinomas from Germany. *Cancer Res* 1992; 52: 3220–3.
- 31 Buetow KH, Sheffield VC, Minghua Z, et al. Low frequency of *P53* mutations observed in a diverse collection of primary hepatocellular carcinomas. *Proc Natl Acad Sci USA* 1992; 89: 9622–6.
- 32 Ozturk M, Bressac B, Puisieux A, et al. *P53* mutation in hepatocellular carcinoma after aflatoxin exposure. *Lancet* 1991; 338: 1356–9.
- 33 Lilleberg SL, Cabonce MA, Raju NR, Wagner LM, Kier LD. Alterations in the structural gene and the expression of *P53* in rat liver tumors induced by aflatoxin B<sub>1</sub>. *Mol Carcinogen* 1992; 6: 159–72.
- 34 Aoyama T, Yamano S, Guzelian PS, Elboin HV, Gonzalez FJ. Five of 12 forms of vaccinia virus-expressed human hepatic cytochrome P<sub>450</sub> metabolically activate aflatoxin B<sub>1</sub>. *Proc Natl Acad Sci USA* 1990; 87: 4790–3.
- 35 Foster PL, Eisenstadt E, Miller JH. Base substitution mutations induced by metabolically activated aflatoxin B<sub>1</sub>. *Proc Natl Acad Sci USA* 1983; 80: 2695–8.
- 36 Wollersheim M, Debelka U, Hofschneider PH. A *trans*-activating function encoded in the hepatitis B virus X gene is conserved in the integrated state. *Oncogene* 1988; 3: 545–52.
- 37 Caselmann WH, Meyer M, Kekulé AS, Lauer U, Hofschneider PH, Koshy R. A novel *trans*-activator is encoded by hepatitis B virus preS/S sequences integrated in human hepatocellular carcinoma DNA. *Proc Natl Acad Sci USA* 1990; 87: 2970–4.
- 38 Kekulé AS, Lauer U, Meyer M, Caselmann WH, Hofschneider PH, Koshy R. The preS2/S region of integrated hepatitis B virus-DNA encodes a transcriptional *trans*-activator. *Nature* 1990; 343: 457–61.
- 39 Meyer M, Caselmann WH, Schlüter V, Schreck R, Hofschneider PH, Baeuerle P. Hepatitis B virus *trans*-activator mHBs: activation of NF- $\kappa$ B, selective inhibition by antioxidants and integral membrane localization. *EMBO J* 1992; 11: 2991–3001.