

RAMAN SPECTROSCOPY WITH ULTRASHORT COHERENT EXCITATION.
NARROWING OF SPECTRAL LINES BEYOND THE DEPHASING LINEWIDTH.

W. Zinth and W. Kaiser
Physik Department der Technischen Universität München
München, Germany

Spectroscopists are constantly faced with the task of improved spectral resolution. Two points are of major interest: (i) The precise frequency of the quantized transition and (ii) the detection of new neighboring transitions. Besides experimental factors the ultimate spectral resolution is determined by the inherent linewidth of the transition. Optical spectroscopists have to deal with different line-broadening processes; for instance with the Doppler effect or with collision broadening in gases, with dephasing processes in condensed systems and with the population relaxation which results in the natural linewidth.

In recent years, different novel techniques have been devised which provide spectral resolution beyond the transition linewidth. For instance, Doppler broadening can be eliminated by saturation spectroscopy or by two counter-propagating beams for two-photon transitions/1/. Even measurements beyond the natural linewidth have been performed taking biased signals from the fluorescent decay /2-5/. Techniques have been proposed where the difference between the decay rates of the two states rather than their sum determines the linewidth /6,7/, and narrowing of the natural linewidth by decaying-pulse excitation has been discussed /8/.

Very recently, we have demonstrated substantial line narrowing of Raman type transitions in condensed phases /9-11/. The lines were broadened by vibrational dephasing. New information was obtained in congested spectral regions.

Theory

In a transient experiment the spectral resolution is not limited by the lifetime of the investigated levels, but is determined by the specific experiment. Under favorable conditions the observed line may become substantially narrower than the spontaneous width measured in a steady-state experiment. We have treated an ensemble of two-level systems of frequency difference ω_0 using the density matrix formalism. Of importance

are the time constants of the system. The population of the upper level decays with the damping constant T_1 and the off-diagonal elements relax with the dephasing time T_2 . The latter determines the linewidth of homogeneously broadened transitions in stationary experiments, $\Delta\nu_{\text{spont}} = 1/\pi T_2$. Quite generally, we may write $1/T_2 = 1/2T_1 + 1/T_{\text{ph}}$, where T_{ph} is related to pure phase disturbing processes.

The spectral resolution may be improved beyond the limit imposed by the spontaneous linewidth $\Delta\nu_{\text{spont}}$ by coherent transient interaction between the electromagnetic fields and the atomic system. We introduce an observable quantity, the expectation value of the transition operator $\langle r \rangle$. It has been shown that $\langle r \rangle$ obeys the equation of a damped harmonic oscillator with driving force $\tilde{A}(t)$ /12,13/.

$$\langle \ddot{r} \rangle + \frac{2}{T_2} \langle \dot{r} \rangle + \omega_0^2 \langle r \rangle = \tilde{A}(t) \quad (1)$$

Introducing plane waves for $A(t)$ and $\langle r \rangle$ with slowly varying amplitudes propagating in the x -direction we write:

$$\tilde{A} = 1/2 A(t) \exp(-i\nu t + ik_A x) + \text{c.c.} \quad (2)$$

$$\langle r \rangle = 1/2 R(t) \exp(-i\omega t + ik_R x) + \text{c.c.} \quad (3)$$

and obtain

$$\frac{\partial R}{\partial t} + \left[i(\omega_0 - \omega) + \frac{1}{T_2} \right] R = \kappa A(t) \quad (4)$$

κ stands for a proportionality constant, ω is the momentary frequency of the transition amplitude. During the excitation process we have $\omega = \nu$, i.e. the system is driven off resonance by $\Delta\omega = \omega_0 - \omega$. Eq. (4) is readily integrated to give

$$R(t, \Delta\omega) = \kappa e^{-t/T_2} \int_{-\infty}^t e^{(i\Delta\omega + 1/T_2)t'} A(t') dt' \quad (5)$$

At this point we wish to specify the investigation we have in mind. We deal with vibrational transitions in molecular liquids. In this case, the transition amplitude $\langle r \rangle$ corresponds to the expectation value of the operator q of the vibrational coordinate. The molecular system is first coherently excited by the stimulated Raman process and the coherent vibrational excitation is subsequently monitored by a properly delayed long probe pulse. The Hamiltonian for the molecular system may be written in the form /13/:

$$H = H^0 - \frac{1}{2} q \sum_{h,i} \left(\frac{\partial \alpha}{\partial q} \right)_{hi} E_h E_i \quad (6)$$

where $\left(\frac{\partial \alpha}{\partial q} \right)$ is the Raman susceptibility which couples the vibration with the electric field E . The subscripts h,i refer to a coordinate system which is fixed to the symmetry axes of the individual molecules. The force exerted by the electromagnetic field E on the vibrating molecules is:

$$A = \frac{1}{2} \sum_{h,i} \left(\frac{\partial \alpha}{\partial q} \right)_{h,i} E_h E_i \quad (7)$$

In our experiments we excite our molecular system by two light pulses. The electric fields of the laser pulse, E_L , and the Stokes shifted pulses, E_S , have the frequency difference $\nu = \nu_L - \nu_S$, the frequency of the driving force.

We recall that the propagation of the light pulses and the interaction with the vibrating molecules are described by Maxwell's equation which leads to the nonlinear wave equation

$$\Delta E - \frac{1}{c^2} \frac{\partial^2}{\partial t^2} (\mu^2 E) = \frac{4\pi}{c^2} \frac{\partial^2}{\partial t^2} P^{NL} \quad (8)$$

μ denotes the refractive index of the medium and the nonlinear polarization P^{NL} couples the light fields and the vibrational mode. Under simple conditions we have for the Raman process:

$$P^{NL} = N \left(\frac{\partial \alpha}{\partial q} \right) \langle r \rangle E \quad (9)$$

where N stands for the number density of molecules. In the probing process the vibrational material excitation, $R(t)$, and the electric field of the probe pulse, E_p , generate a scattered Stokes (and anti-Stokes) wave E_{S2} . It has been shown that Eqs. (8) and (9) give Eq. (10) /13/:

$$\frac{\partial E_{S2}}{\partial x} \propto R(t) E_p(t) \quad (10)$$

Experimentally we observe the time-integrated scattered intensity I_{S2} as a function of time delay T_D between the exciting and the probing pulse.

Very recently we have demonstrated that coherent probe scattering may lead to sub-linewidth resolution of Raman transitions /9-11/. Short excitation and prolonged interrogation (SEPI) was used. The method is shown schematically in Fig.1. A short driving force $A(t)$ at a frequency ν (i.e., two pulses E_L and E_S with $\nu = \nu_L - \nu_S$) near the resonance ω_0 of the

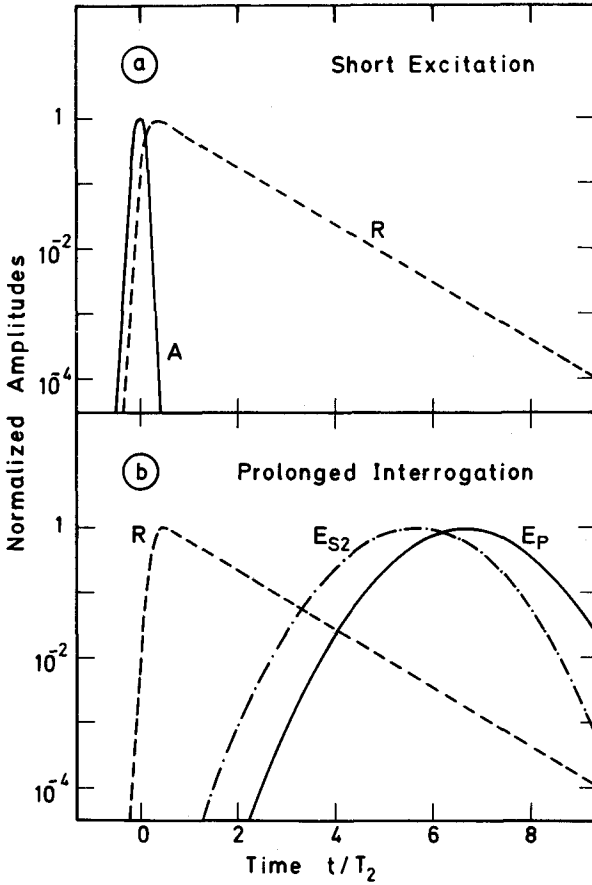

Fig. 1 The short excitation and prolonged interrogation (SEPI) technique. (a) A short driving pulse, $A(t)$, excites the exponentially decaying transition amplitude $R(t)$. (b) The transition amplitude $R(t)$ is interrogated by a long pulse E_p giving rise to the scattered pulse $E_s(t)$.

quantum system generates a transition amplitude $R(t)$ (see Fig.1a). The driving force has a short duration or is switched off rapidly at $t=0$. After the excitation the exponentially decaying transition amplitude $R(t)$, oscillating freely at ω_0 , is investigated by a prolonged probing pulse at frequency ω_p . A pulse with suitably shaped amplitude $E_p(t)$ generates the scattered signal $E_{S2}(t)$ with frequency $\omega_{S2} = \omega_p \pm \omega$. The frequency spectrum of the scattered intensity is observed. $I_{S2}(\omega_{S2})$ has the form:

$$\begin{aligned}
 I_{S2}(\omega_{S2}) &\propto \left| \int_{-\infty}^{+\infty} dt E_{S2}(t) e^{i\omega_{S2}t} \right|^2 \propto \\
 &\propto \left| \int_{-\infty}^{+\infty} e^{i\omega_{S2}t} E_p(t) R(t) e^{-i(\omega_p \pm \omega)t} dt \right|^2
 \end{aligned}
 \quad (11)$$

Introducing $\Delta\omega = \omega_S - \omega_P \pm \omega_0$ and $t_e = t_p^2 / (T_2 \times 4 \ln 2)$ and using a Gaussian shape $E_p(t) = E_{p_0} \exp(-((t-T_D)/t_p)^2 2 \ln 2)$ for the delayed probing pulse we obtain at late delay time T_D a Gaussian shaped spectrum centered at the frequency $\omega_P \pm \omega_0$:

$$I_{S2}(T_D, \Delta\omega) \propto e^{-2T_D/T_2 - (t_e/t_p)^2 4 \ln 2} \times \left| \int_{-T_D}^{\infty} e^{i\Delta\omega t} e^{-[(t-t_e/t_p)]^2 2 \ln 2} dt \right|^2 \quad (12)$$

For a long delay time T_D the width of the observed spectrum is only determined by the duration of the probing pulse. For a sufficiently long pulse, $t_p > 1.4 T_2$, the SEPI lines are narrower than the spontaneous width.

The probing with longer pulses and at later times T_D leads to a loss of scattered signal (see Eq.(12)). We have calculated the peak intensity of the scattered signal as a function of spectral narrowing. We find a signal reduction of approximately 10^6 for a narrowing of four. These values are experimentally feasible.

Experimental System

The short dephasing times in molecular liquids require picosecond pulses in order to measure SEPI spectra. We use exciting pulses with a band width of $\approx 10 \text{ cm}^{-1}$ tuned in steps over a larger frequency range. For each excitation band the coherent spectrum was recorded by a spectrograph with sufficient resolution. Fig.2 shows the schematic of our experimental system. At the top, l.h.s., a single frequency doubled pulse from a mode-locked Nd-glass laser system enters the figure. This pulse of frequency $\nu_1 = 18,990 \text{ cm}^{-1}$ is split in three parts by two consecutive beam splitters. The pulse in beam 1 passes through the polarizer P1 and the sample, but is blocked by the polarizer P2 in its straight path. In the center beam 2 of Fig.2 a new frequency ν_S is produced in the generator by a stimulated Raman process. Changing the medium of the generator one readily obtains pulses of different frequencies ν_S . These pulses are blocked by the polarizer P2 and are spectrally monitored by spectrograph SP2. On account of the transient generation process the pulses of frequency ν_S are shorter in duration than the incident pulses ν_L by a factor of approximately three /14/. The two pulses of the beams 1 and 2 enter simultaneously the sample coherently exciting molecular

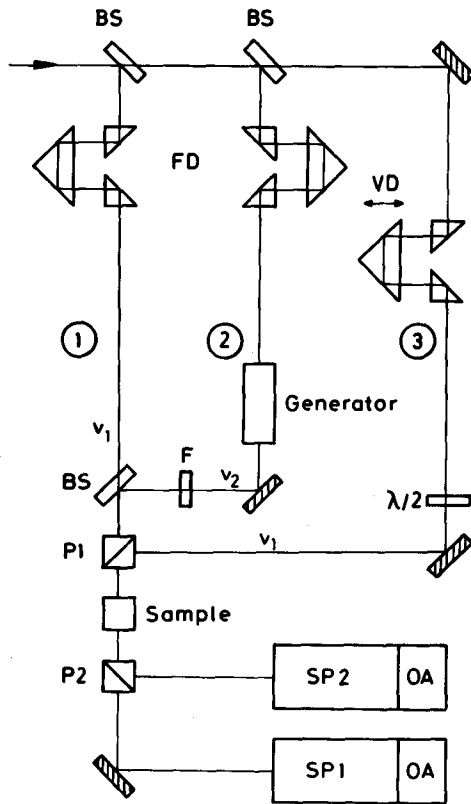

Fig. 2 Schematic of the experimental system used for the study of SEPI spectra of liquids. Beam splitters BS, variable and fixed delay VD and FD, polarizers P1 and P2, blocking filter F, spectrographs SP1 and SP2, used in conjunction with optical spectrum analysers OA.

vibrations via transient stimulated Raman scattering at frequency $\nu = \nu_L - \nu_S$. In the optical path 3 a delayed pulse with polarisation perpendicular to the pulses of 1 and 2 is produced. This third pulse interacts with the coherently excited molecules of the sample producing a Raman shifted signal pulse. Using Stokes scattering the three pulses travel collinearly through the sample. When anti-Stokes scattering is used, the probing pulse crosses the beam direction of the exciting pulses at the phase matching angle. The spectrum of the coherently scattered light is studied by a 2 m spectrograph SP1 and a cooled optical spectrum analyser OA. The experimental system has a resolution of 0.2 cm^{-1} per channel and an absolute accuracy of the frequency scale of 0.4 cm^{-1} .

Experimental Results

We have performed SEPI measurements using a number of organic and anorganic liquids. First we present results on liquid CH_3CCl_3 , where a single Lorentzian shaped Raman line exists at 2939 cm^{-1} . Second, we compare the spontaneous Raman spectrum of CCl_4 at 460 cm^{-1} with a SEPI spectrum. Third, we show results on liquid C_6H_{12} , where broad and overlapping lines occur between 2850 and 2940 cm^{-1} , in the common spontaneous Raman spectrum.

A. Liquid 1.1.1. Trichloroethane

In Fig. 3 we show the Raman band of a CH_3 -stretching mode at 2939 cm^{-1} of liquid CH_3CCl_3 measured with a standard laser Raman spectrometer. The

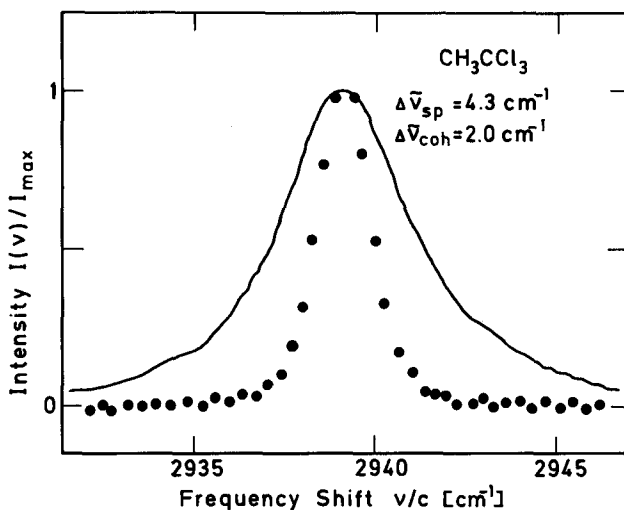

Fig. 3 Spontaneous Raman spectrum (solid curve) and coherent probing (SEPI) spectrum taken at $t_D=18.5 \text{ ps}$. The CH_3 -stretching mode of CH_3CCl_3 is investigated. Note the narrow SEPI spectrum.

Lorentzian shaped line (solid curve) has a bandwidth of $\Delta\nu_{\text{spont}} = 4.3 \text{ cm}^{-1}$. Quite different is the bandwidth of the coherent probing (SEPI) spectrum taken at a delay time of $t_D = 18.5 \text{ ps}$. Now we find a bandwidth of $\Delta\nu_{\text{coh}} = 2.0 \text{ cm}^{-1}$; i.e., we have a spectral narrowing of a factor of two. The frequency of the Stokes shift of the SEPI spectrum is 2938.2 cm^{-1} in agreement with the spontaneous value of 2939 cm^{-1} . In this experiment

the pulse duration of the exciting and the probing pulse is 5 ps and 10 ps, respectively.

B. Carbon Tetrachloride

The natural abundance of chlorine, $^{35}\text{Cl}:^{37}\text{Cl} = 75.5:25.5$, lead to five components of CCl_4 : 32.5% C^{35}Cl_4 , 42.2% $\text{C}^{35}\text{Cl}_3^{37}\text{Cl}$, 20.5% C^{35}Cl_2 , 4.4% $\text{C}^{35}\text{Cl}^{37}\text{Cl}_3$, and 0.4% C^{37}Cl_4 . As a result, the symmetric vibrational mode $\nu_1(a_1)$ at 460 cm^{-1} consists of four major components /15/. The spontaneous Raman spectrum of Fig.4 shows, indeed, four peaks, the intensity of which is in good agreement with the distribution of the four major

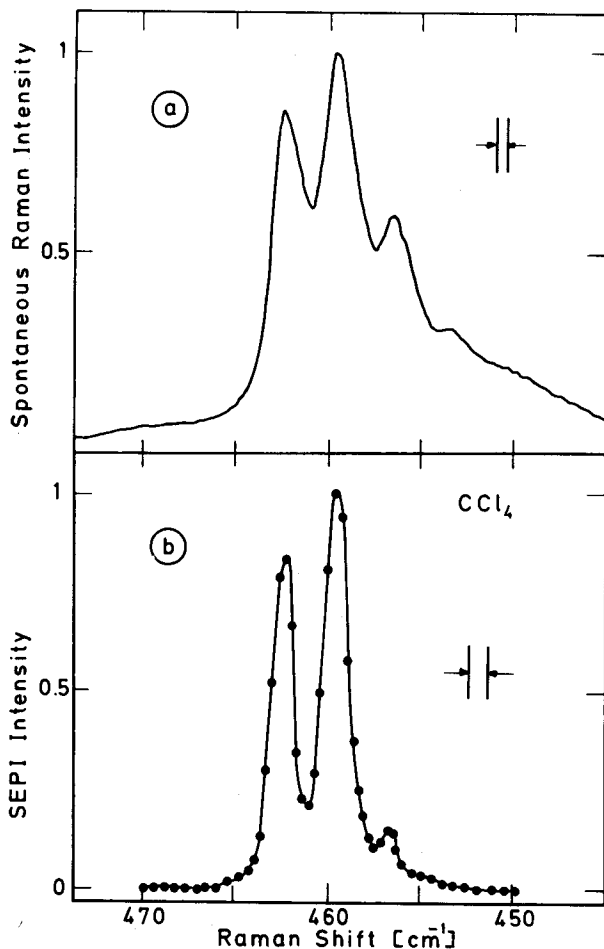

Fig. 4 Raman spectra of the ν_1 mode of liquid CCl_4 . (a) Polarized spontaneous Raman spectrum, instrumental resolution 0.5 cm^{-1} . (b) SEPI spectrum of CCl_4 . Instrumental resolution 1 cm^{-1} .

molecular species. The different Raman lines in Fig.4a overlap strongly inspite of the high resolution of the Raman spectrometer of 0.5 cm^{-1} . The individual Raman lines are broadened by the dephasing time $T_2 = 6.0 \text{ ps}$, which gives rise to the observed width $\Delta\nu_{\text{spont}} = 1/\pi cT_2 = 1.8 \text{ cm}^{-1} / 16/$.

The SEPI spectrum of the same vibrational mode of CCl_4 is depicted in Fig.4b. In this case the sample was excited for approximately 7 ps by a laser pulse and a second Stokes shifted pulse ($\nu_L - \nu_S = 458 \text{ cm}^{-1}$). Under these conditions the two neighboring major molecular components are strongly excited and give rise to the observed strong scattering spectrum. The data of Fig.4b were obtained with long probing pulses of $t_p = 20 \text{ ps}$ and at a delay time of 40 ps . We point to the sharp lines in the SEPI spectrum which are narrower than $\Delta\nu_{\text{spont}}$ in the spontaneous spectrum of Fig. 4a. The depicted linewidths in Fig.4b are determined by the limited spectral resolution of the spectrometer.

C. Liquid Cyclohexane

As another example for the short excitation and prolonged interrogation (SEPI) technique we present Raman data of cyclohexane in the small frequency range between 2850 cm^{-1} and 2940 cm^{-1} . In Fig.5b the polarized spontaneous Raman spectrum is depicted. This spectrum was taken with an Ar^+ laser and a Raman spectrometer with a resolution better than 1 cm^{-1} . The three strong Raman bands correspond to CH-stretching modes and the diffuse spectrum between 2860 cm^{-1} and 2920 cm^{-1} is considered to be due to overlapping overtones and combination modes which are enhanced by Fermi resonance with the fundamentals /17,18/.

In Fig.5c we show three SEPI spectra on an expanded scale (factor 3.7). Each spectrum was obtained by a single laser shot. On the r.h.s. we present the sharp SEPI band corresponding to the CH-stretching mode at 2923 cm^{-1} . The small linewidth of 2.3 cm^{-1} allows to determine the peak position accurately to $2922.0 \pm 0.7 \text{ cm}^{-1}$. We note that the SEPI band is considerably smaller than the corresponding band in the spontaneous Raman spectrum of Fig.5b, the latter being asymmetric on account of other smaller Raman transitions. The Raman transition at 2923 cm^{-1} was excited using ethylene glycol, $(\text{CH}_2\text{OH})_2$, in the generator cell of Fig.2.

The SEPI spectrum of Fig.5c, middle, shows four Raman transitions. Lines as close as 2.5 cm^{-1} are clearly resolved. The four transitions are hidden under the wing of the strong Raman band at 2923 cm^{-1} ; they cannot be detected in the conventional Raman spectrum of Fig.5b. The SEPI spectrum is obtained by using an exciting pulse ν_S with a frequency

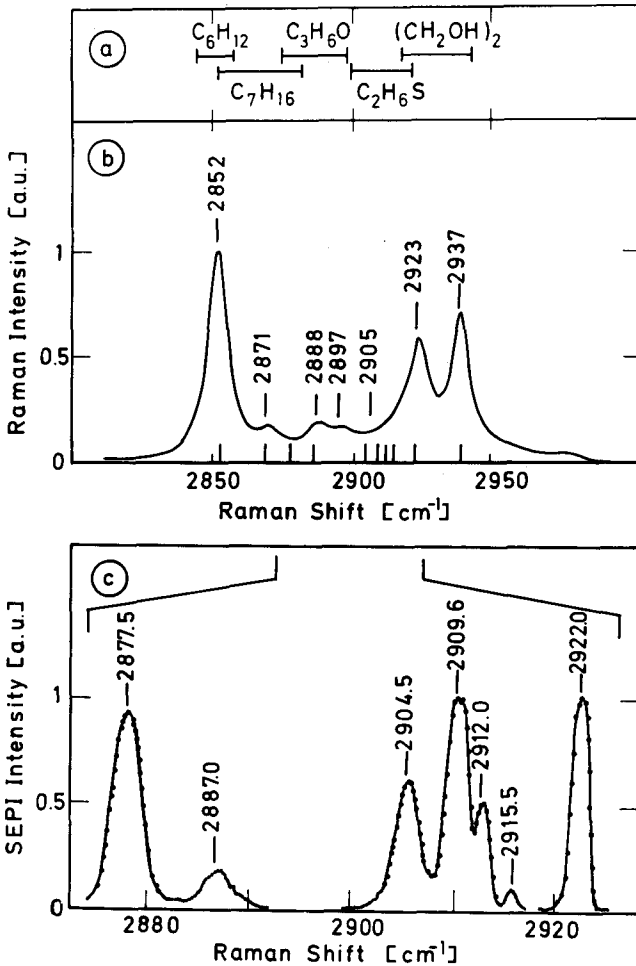

Fig. 5 Experimental results of short excitation and prolonged interrogation (SEPI) spectroscopy of C_6H_{12} . (a) Frequency range of the various generator liquids used in the experiment. (b) Polarized spontaneous Raman spectrum of C_6H_{12} recorded with a resolution of 1 cm^{-1} . The frequency positions of the resonances found in SEPI spectra are marked by vertical lines. (c) Three SEPI spectra taken with different generator liquids. New Raman lines are detected and the spectral resolution is improved. (Note, the frequency scale of c is 3.7 times larger than the one of b).

band extending from 2900 cm^{-1} to 2920 cm^{-1} (dimethyl sulfide, C_2H_6S , in the generator).

In Fig.5c, l.h.s., we depict a SEPI spectrum obtained after excitation by a ν_S pulse by a spectral band width extending from 2875 cm^{-1} to 2890 cm^{-1} (propylene oxide, C_3H_6O). We find two distinct Raman bands at

2877.5 cm^{-1} and 2887 cm^{-1} . The band at 2877.5 cm^{-1} has never been reported previously. It is buried in the diffuse part of the conventional Raman spectrum (see Fig.5b).

A final assignment of the new Raman lines between 2870 cm^{-1} and 2920 cm^{-1} has not yet been made. Inspection of the lower fundamental modes suggest overtones and combination modes in this frequency range. Of special interest is the new Raman line at 2912 cm^{-1} which coincides precisely with an infrared active mode of the molecule. It appears that we observe here a Raman forbidden mode.

Additional Observations and Comments

The following points are relevant for the application of the SEPI technique: (i) The frequency positions of the observed Raman lines are independent of the excitation conditions since we observe freely relaxing molecules. We have tested this notion by exciting our sample with narrow or with broad pulses of similar central frequency ν_S . This experiment is readily performed using different media in the generator cell. The advantage of a broad frequency spectrum of the incident pulse is to provide initial conditions for several Raman transitions in congested frequency regions. One can observe several Raman lines with one shot (see Fig.5c, middle). (ii) In SEPI experiments the exciting and interrogating pulses should not overlap temporarily in order to avoid the generation of a coherent signal via the nonresonant four-photon parametric process. For this reason, the delay time of the third probing pulse has to be sufficiently large. One roughly estimates delay times of $t_D = 20$ to 25 ps for dephasing times $T_2 \approx 1$ ps and Gaussian probing pulses of 8 ps duration. The SEPI spectra are observed with good accuracy, approximately five orders of magnitude below the peak value at $t_D = 0$. (iii) The maxima of the SEPI spectra are not proportional to the Raman scattering cross-section, since the initial conditions of the exciting pulses and the T_2 times are important parameters for the observed magnitude of the generated signal. SEPI spectra taken for different delay times allow an estimate of the dephasing times T_2 . (iv) The frequency precision of the generated Stokes spectrum depends upon the frequency stability of the interrogating pulse. For highest accuracy the frequency ν_L has to be measured simultaneously with the SEPI spectrum. Interrogating pulses with a chirped frequency spectrum give unwanted shifts of the SEPI spectra and should thus be avoided. (v) The scattering process may also be performed on the anti-Stokes side of the spectrum. The disturbing inter-

ference found in stationary CARS spectroscopy does not occur for the delayed probing used with the SEPI spectroscopy /9,19/. (vi) A simultaneous measurement of the coherent Stokes and anti-Stokes SEPI spectra allows to eliminate the effect of a chirped probing pulse. In this way, the absolute frequency position is obtained with high accuracy /9/.

Concluding Remarks

The data presented in this article convincingly show the usefulness of the short excitation and prolonged probing technique. It is possible to obtain molecular information which are not found by other existing spectroscopic techniques.

References

1. For a review see: H. Walther, in "Laser Spectroscopy of Atoms and Molecules", Topics in Applied Physics, Vol.2, Ed. H. Walther, Springer, Heidelberg 1976, p.1.
2. G. Copley, B.P. Kibble and G.W. Series, J. Phys. B1 (1968) 724.
3. H. Figger and H. Walther, Z. Physik 267 (1974) 1.
4. H. Metcalf and W. Phillips, Opt. Lett. 5 (1980) 540.
5. F. Shimizu, K. Umezu and H. Takuma, Phys. Rev. Lett. 47 (1981) 825.
6. P. Meystre, M.O. Scully and H. Walther, Opt. Commun. 33 (1980) 153.
7. H.-W. Lee, P. Meystre and M.O. Scully, Phys. Rev. A24 (1981) 1914.
8. P.E. Coleman, D. Kagan and P.L. Knight, Opt. Commun. 36 (1981) 127.
9. W. Zinth, Opt. Commun. 34 (1980) 479.
10. W. Zinth, M.C. Nuss and W. Kaiser, Chem. Phys. Lett. 88 (1982) 257.
11. W. Zinth, M.C. Nuss and W. Kaiser, to be published in Opt. Commun.
12. J.A. Giordmaine and W. Kaiser, Phys. Rev. 144 (1966) 676.
13. A. Laubereau and W. Kaiser, Rev. Mod. Phys. 50 (1978) 607.
A. Penzkofer, A. Laubereau and W. Kaiser, Progr. Quant. Electron. 6 (1979) 55.
14. R.L. Carman, F. Shimizu, C.S. Wang and N. Bloembergen, Phys. Rev. A2 (1970) 60.
15. J. Brandmüller, K. Buchardi, H. Hacker and H.W. Schrötter, Z. Angew. Phys. 22 (1967) 177.
16. W. Zinth, H.J. Polland, A. Laubereau and W. Kaiser, Appl. Phys. B26 (1981) 77.
17. K.W.F. Kohlrausch and W. Wittek, Z. Phys. Chem. B48 (1941) 177.
18. K.B. Wiberg and A. Shrake, Spectrochim. Acta 27A (1971) 1139.
19. W. Zinth, A. Laubereau and W. Kaiser, Opt. Commun. 26 (1978) 457.