



Open Archive Toulouse Archive Ouverte (OATAO)

OATAO is an open access repository that collects the work of Toulouse researchers and makes it freely available over the web where possible.

This is an author-deposited version published in: <http://oatao.univ-toulouse.fr/>
Eprints ID: 6537

To link to this article: DOI:10.1016/j.jclepro.2011.09.011
<http://dx.doi.org/10.1016/j.jclepro.2011.09.011>

To cite this version:

Boix, Marianne and Montastruc, Ludovic and Pibouleau, Luc and Azzaro-Pantel, Catherine and Domenech, Serge *Industrial water management by multiobjective optimization: from individual to collective solution through eco-industrial parks*. (2012) *Journal of Cleaner Production*, vol. 22 (n° 1). pp. 85-97. ISSN 0959-6526

Any correspondence concerning this service should be sent to the repository administrator:
staff-oatao@inp-toulouse.fr

Industrial water management by multiobjective optimization: from individual to collective solution through eco-industrial parks

Marianne Boix, Ludovic Montastruc, Luc Pibouleau*, Catherine Azzaro-Pantel, Serge Domenech

Laboratoire de Génie Chimique (LGC), Centre National de la Recherche Scientifique (CNRS), Institut National Polytechnique de Toulouse (INPT), Université de Toulouse, 4, Allée Emile Monso, BP 84234, 31432 Toulouse, France

A B S T R A C T

Industrial water networks are designed in the first part by a multiobjective optimization strategy, where fresh water, regenerated water flow rates as well as the number of network connections (integer variables) are minimized. The problem is formulated as a Mixed-Integer Linear Programming problem (MILP) and solved by the ϵ -constraint method. The linearization of the problem is based on the necessary conditions of optimality defined by Savelski and Bagajewicz (2000). The approach is validated on a published example involving only one contaminant. In the second part the MILP strategy is implemented for designing an Eco-Industrial Park (EIP) involving three companies. Three scenarios are considered: EIP without regeneration unit, EIP where each company owns its regeneration unit and EIP where the three companies share regeneration unit(s). Three possible regeneration units can be chosen, and the MILP is solved under two kinds of conditions: limited or unlimited number of connections, same or different gains for each company. All these cases are compared according to the global equivalent cost expressed in fresh water and taking also into account the network complexity through the number of connections. The best EIP solution for the three companies can be determined.

Keywords:

Water network
Multiobjective optimization
MILP
Eco-industrial park

1. Introduction

During the last decades, many developed countries have increased their investment in environmental research and development due to an increasing depletion of natural resources such as fresh water for instance (UNESCO, 2009). With the increasing interest for global environment preservation, the unlimited resources paradigm became little by little obsolete. In 2008, the global needs in fresh water were estimated to be 4000 km³ (UNESCO, 2009), where 20% were used by industry and have been globally increased by a factor of four during the last 50 years (Oecd, 2008). The environmental impact induced by the process industry is linked both to the high volumes involved and to the diversity of toxic products generated along the processing chain. Consequently, a real need to define optimized water networks so as to reduce the impact of contaminants on the environment, has recently emerged.

Although the world concern of sustainable development gave birth to a lot of works during the last decades, the concept of Industry linked to Ecology is quite much older. Indeed, since the beginning of the twentieth century, scientists are worried about designing clean industries. Several studies stated the recycling of by-products of an industry by another one (Simmonds, 1862; Conover, 1918). These studies did not introduce any official term on what they dealt for. "Industrial Ecology" really appeared (Hoffman, 1971) in the 1970's and Japanese and Belgian studies went deeper in this topic (Watanabe, 1972; Gussow and Meyers, 1970). However, Frosch and Gallapoulos (1989) popularized this term twenty years ago from the idea that we should use the analogy of natural systems as an aid in understanding how to design sustainable industrial systems. As they indicate the ideal ecosystem, in which the use of energy and materials is optimized, wastes and pollution are minimized and there is an economically viable role for every product of a manufacturing process, will not be attained soon. It was true in 1989, and it is always true today.

Industrial Ecology has been defined by Allenby (2006) as "a systems-based, multidisciplinary discourse that seeks to understand emergent behaviour of complex integrated human/natural systems". In most of the researches in Industrial Ecology the common guideline is that natural systems do not have waste in

* Corresponding author. Tel.: +335 34 32 36 58; fax: +335 34 32 37 00.

E-mail addresses: marianne.boix@ensiacet.fr (M. Boix), ludovic.montastruc@ensiacet.fr (L. Montastruc), luc.pibouleau@ensiacet.fr (L. Pibouleau), catherineazzaropantel@ensiacet.fr (C. Azzaro-Pantel), serge.domenech@ensiacet.fr (S. Domenech).

Nomenclature			
w_1^j	fresh water flow rate going to the process j (T/h)	R	contribution of the regenerated water flow rate in GEC (T/h)
$wp_i^{j \rightarrow k}$	partial flow rate of the component i between two processes j and k (T/h)	W	contribution of the waste water flow rate in GEC (T/h)
$wpr_i^{j \rightarrow m}$	partial flow rate of the component i from the process j to the regeneration unit m (T/h)	<i>Abbreviations</i>	
wd_i^j	discharged partial mass flow of the component i from the process j (T/h)	DWN	Design of Water Network
$wr_i^{m \rightarrow n}$	partial mass flow of the component i between two regeneration units m and n (T/h)	WAP	Water Allocation Problem
$wrp_i^{m \rightarrow j}$	partial mass flow of the component i from the regeneration unit m to the process j (T/h)	GAMS	Generalized Algebraic Modelling System
wrd_i^m	discharged partial mass flow of the component i from the regeneration unit m (T/h)	EIP	Eco-Industrial Park
M_i^j	amount of contaminant i generated by the process j (g/h)	MILP	Mixed-Integer Linear Programming
$Cmax_j^{in}$	maximal concentration at the input of the process j (g/T)	MINLP	Mixed-Integer NonLinear Programming
$Cmax_j^{out}$	maximal concentration at the output of the process j (g/T)	NLP	NonLinear Programming
ENC	equivalent number of connections	LP	Linear Programming
F_1	fresh water flow rate at the network entrance (T/h)	<i>Greek letters</i>	
F_2	water flow rate at inlets of regeneration units (T/h)	α	cost factor for regenerated water
F_w	waste water flow rate (T/h)	β	cost factor for waste water
F_3	number of connections into the network	<i>Subscripts</i>	
GEC	global equivalent cost in fresh water (T/h)	i	component, with $i = 1$ for fresh water and $i > 1$ for contaminants
		<i>Superscript</i>	
		o	outlet
		j, k	processes
		m, n	regeneration units

them, so our systems should be modeled from natural ones if we want them to be sustainable.

Without falling into the trap of abstruse ecological discourses, many difficult societal and/or industrial problems appear under the generic term of Industrial Ecology. Building a sustainable industry is slightly linked to the term Industrial Symbiosis. According to Chertow (2000), an industrial symbiosis engages "separate industries in a collective approach to competitive advantage involving physical exchange of materials, energy, water and by-products". A primordial feature of an industrial symbiosis is the collaboration offered by the geographic proximity of the several companies. Most widespread manifestations of an industrial symbiosis are Eco-Industrial Parks. The term "eco-industrial park" is the subject of many debates due to its definition, difficult to formulate rigorously. However, a definition commonly adopted is "an industrial system of planned materials and energy exchanges that seeks to minimize energy and raw materials use, minimize waste, and build sustainable economic, ecological and social relationships" (PCSD, 1996; Alexander et al., 2000). This definition was later reported by Côté and Cohen-Rosenthal (1998). Obviously, a basic condition for an EIP to be economically viable is to demonstrate that the sum of benefits achieved by working as collective is higher than working as a stand-alone facility.

There is some amount of uncertainty in this type of optimization model. For instance, the mass loads of contaminants for water-using processes or any other parameter that may change during the operation process. Although some studies (Sahinidis, 2004; Karuppiah and Grossmann, 2008) have incorporated these uncertainties to design industrial water networks, the objectives of this study.

The first part of this paper aims at defining a general methodology by taking into account only the single contaminant case for the Design of Water Networks (DWN). The generic problem is formulated under a MILP form with integer variables related to the connections into the network. The biobjective optimization of the fresh water flow rate at the network entrance and the water flow

rate at regeneration unit inlets, parameterized by the number of connections, is carried out according to a lexicographic procedure. The approach, validated on a published example involving ten processes and one regeneration unit, is extended in the second part to eco-industrial parks (EIP). The last part deals with several EIP configurations in order to evaluate the feasibility of each solution.

2. Previous works

Historically, the design of water network (DWN) was carried out not for EIP purposes, but for a stand-alone company by means of graphical methodologies (Dunn and Wenzel, 2001; Jacob et al., 2002; Linnhoff and Vredeveld, 1984; Manan et al., 2006; Wan Alwi, 2008), mathematical programming (Bagajewicz and Savelski, 2001; Feng et al., 2008; Huang et al., 1999) and synthesis of mass exchange networks (El-Halwagi, 1997; Hallale and Fraser, 2000; Shafiei et al., 2004). Designing water networks refers to allocate the streams of the networks between several units while respecting constraints and satisfying objectives. Water allocation problems (WAP) were widely studied during the last decades due to the growing interest for sustainable development in industries (de Faria and de Souza, 2009; Kumaraprasad and Muthukumar, 2009; Klemes et al., 2010; Poplewski et al., 2010). Linear formulations implemented for maximizing water regeneration and reuse into industrial processes has been first developed in a lot of previous works (Bagajewicz and Savelski, 2001; El-Halwagi, 1997; El-Halwagi et al., 2004; Wang and Smith, 1994). These techniques are limited to single contaminant networks (Gomes et al., 2007), which are the main subject of the present study. Another strategy has already been adopted regarding the resolution of WAP, it consists in multiobjective optimization using genetic algorithm (Lavric et al., 2005). Nonlinear strategies based on the relaxation of the bilinear terms involved in the balance equations are presented in the works of Quesada and Grossmann (1995) and Galan and Grossmann (1998). Even if significant advances have been performed in the field on nonlinear mixed-integer

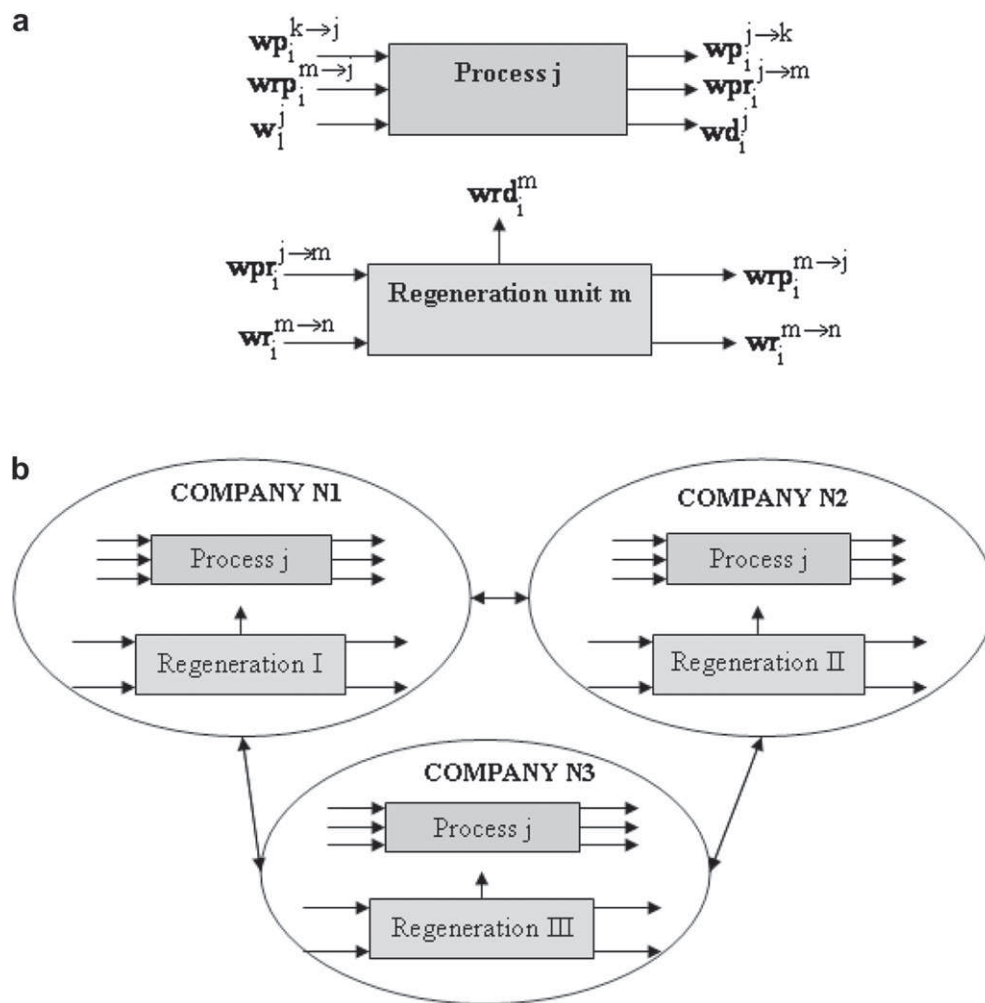

Fig. 1. Superstructures for a company (a), and an EIP (b).

programming, the search for a solution of a linear problem is always easier than in the nonlinear case. This concerns both the global optimality of the solution found, and the ease to initialize the search. Furthermore, MILP methods may support important numbers of variables and high combinatorial aspects. These issues are important when dealing with EIPs. In most of previous works, DWN was carried out only for monocontaminant networks, but in a recent paper Boix et al. (2011) deal with multicontaminant problems. In that case, the MILP problem becomes a MINLP one; that is the reason why this study is restricted to the monocontaminant case.

EIP problems for managing industrial water were solved by mathematical programming either by using NLP (NonLinear Programming), MILP (Mixed-Integer linear Programming) or MINLP (Mixed-Integer NonLinear programming) procedures (Aviso et al., 2010a, 2010b; Chew et al., 2008, 2010a, 2010b; Lovelady and El-Halwagi, 2009; Kim et al., 2010). What is giving cause for concern in numerous research works is to deal with conflicting objectives (Erol and Thöming, 2005). However, new strategies have been adopted in order to compensate for this problem like a bi-level fuzzy optimization developed by Aviso et al. (2010a, 2010b). Furthermore, a lot of research has been devoted to develop some indicators to evaluate the satisfaction of each participant of the IEP (Tiejun, 2010; Zhu et al., 2010). Other recent works implement the game theory for solving the problem (Chew et al., 2009, 2010c) and

various approaches consider that an EIP is comparable to biological or ecological natural systems (Liwarska-Bizukojc et al., 2009; Tiejun, 2010). All these studies choose classical objectives: the fresh water consumption or the satisfaction of participants but Lim and Park (2008) focused on the necessity of reducing the total carbon footprint of participant's water supply systems.

However EIPs have to face two main classes of challenges that can determine their development. The former is the Technical/Economic challenge: if the exchanges among the participants are unfeasible, no EIP can be successful. Indeed a real connectivity must exist between the companies within the EIP. The latter related to the organizational/commercial points can represent the biggest hurdle. However this second thorny issue will not be tackled in this paper related to the implementation of an EIP for managing industrial waters. Chertow identified that certain precursors of symbiosis can be regeneration or waste water reuse and can lead to more extensive symbiotic cooperation as well (Chertow, 2007).

Several successful examples of EIPs located all around the world particularly in North America (Côté and Cohen-Rosenthal, 1998; Gibbs and Deutz, 2005, 2007; Heeres et al., 2004), Western Europe (Baas and Boons, 2004; Heeres et al., 2004; Mirata, 2004; Van Leeuwen et al., 2003), and Australia (Roberts, 2004; Van Beers et al., 2007; Van Berkel, 2007; Giurco et al., 2010). More recently, new eco-parks have been implanted in other countries such as China (Geng and Hengxin, 2009; Liu et al., 2010; Shi et al., 2010),

Brazil (Veiga et al., 2009) or Korea (Oh et al., 2005; Park et al., 2008). A good review of several successful of EIP had been raised by Tudor et al. (2007).

As cited by Tibbs (1993) about the creation of industrial ecosystems "Industrial ecosystems are a logical extension of life-cycle thinking, moving from assessment to implementation. They involve "closing loops" by recycling, making maximum use of recycled materials in new production, optimizing use of materials and embedded energy, minimizing waste generation, and reevaluating "wastes" as raw material for other processes." The present work, related to the management of industrial water, comes within this scope. Furthermore from Baas (2006) and Sakr et al. (2011), this study is situated at the micro level of the Cleaner Production Systems.

3. Multiobjective MILP problem

3.1. Problem statement

Given a set of regeneration units and processes, the objective is to determine a network of connections of water streams among them so that both the overall fresh water consumption and the regenerated water flow rate are minimized. Each process has limited inlet and outlet concentrations and regeneration units are defined by their outlet concentration. The particular case of an EIP can be assimilated to a bigger company divided into blocks (each block is in fact a company). The purpose is to design an optimal network (for a company or for an EIP) where all the requirements in terms of contaminant concentrations for each process are respected.

3.2. Superstructures definition

In the company superstructure, all the possible connections between processes and regeneration units may exist, except recycling to the same regeneration unit or process. For each water-using process, input water may be fresh water, used water coming from other processes and/or recycled water; the output water for such a process may be sent towards the discharge, or to other processes and/or to regeneration units. Similarly, for a regeneration unit, input water may come from processes or from other regeneration units. Regenerated water may be reused in the processes or sent towards other regeneration units. (Fig. 1a) In order to define a generic formulation, the physical or chemical operation (reaction, separation ...) performed in each process j is not taken into account. However, a process j generates a mass of contaminant due to its own working. This contamination is expressed in g/h and noted: $M_{i>1}^j$, this value imposed by the process itself, is fixed by the user.

The same superstructure is also adopted for each company involved in an EIP (Fig. 1b) and the connections between the different companies will be defined in Section 4 where several examples are studied.

3.3. Process modelling

In most previous works, the water allocation problem is generally solved with an MINLP optimization (Feng et al., 2008). Indeed, the model-based problem contains bilinear terms due to products in mass balances for contaminants. These bilinearities are caused by the products of concentrations and flow rates (Sienutydz and Jezowski, 2009).

In this study, the formulation is based upon the necessary conditions of optimality developed by Savelski and Bagajewicz (2000) that relies on the elimination of these bilinearities for a single contaminant water network. The modeling equations are

the same as used in Boix et al. (2010), involving partial mass flows; that is to say that contaminants are represented by flow rates (in g/h) instead of concentrations (in ppm). The partial contaminant flow rate is linked to the contaminant concentration also involving the partial water flow rate (in T/h) by this definition (assuming a flow stream going from process j to process k):

$$\frac{w_{i>1}^{j \rightarrow k}}{w_1^{j \rightarrow k} + w_{i>1}^{j \rightarrow k}} = C^{j \rightarrow k} \quad (1)$$

The denominator: $w_1^{j \rightarrow k} + w_{i>1}^{j \rightarrow k}$ represents the total flow rate of the stream. This term can be reduced regarding units of flow rates. Indeed, $w_1^{j \rightarrow k}$ is expressed in T/h whereas $w_{i>1}^{j \rightarrow k}$ unit is g/h (10^{-6} T h^{-1}) what supports the relation (2) and leads to the Equation (3) giving the definition used in this study for a partial contaminant flow rate.

$$\frac{w_{i>1}^{j \rightarrow k}}{w_1^{j \rightarrow k}} = C^{j \rightarrow k} \quad (2)$$

$$w_{i>1}^{j \rightarrow k} = C^{j \rightarrow k} \times w_1^{j \rightarrow k} \quad (3)$$

As a result of these assumptions, the mass balances for flow rates are written as follows:

- For a given process j , the inlet water ($i = 1$) flow rate is equal to the outlet water flow rate:

$$w_1^j + \sum_k w p_1^{k \rightarrow j} + \sum_m w r p_1^{m \rightarrow j} = w d_1^j + \sum_k w p_1^{j \rightarrow k} + \sum_m w p r_1^{j \rightarrow m} \quad (4)$$

- For a given process j , the inlet contaminant ($i > 1$) flow rate plus the contaminant mass load is equal to the outlet contaminant flow rate:

$$\sum_k w p_{i>1}^{k \rightarrow j} + \sum_m w r p_{i>1}^{m \rightarrow j} + M_{i>1}^j = w d_{i>1}^j + \sum_k w p_{i>1}^{j \rightarrow k} + \sum_m w p r_{i>1}^{j \rightarrow m} \quad (5)$$

- For a given regeneration unit m , the inlet water flow rate is equal to the outlet water flow rate:

$$\sum_n w r_1^{n \rightarrow m} + \sum_j w p r_1^{j \rightarrow m} = w r d_1^m + \sum_j w r p_1^{m \rightarrow j} + \sum_n w r_1^{m \rightarrow n} \quad (6)$$

- For a given regeneration unit m , the inlet contaminant flow rate is equal to the outlet contaminant flow rate:

$$\sum_n w r_{i>1}^{n \rightarrow m} + \sum_j w p r_{i>1}^{j \rightarrow m} = w r d_{i>1}^m + \sum_j w r p_{i>1}^{m \rightarrow j} + \sum_n w r_{i>1}^{m \rightarrow n} \quad (7)$$

- The overall fresh water flow rate is equal to the total discharged water flow rate:

$$\sum_m w r d_1^m + \sum_j w d_1^j = \sum_j w_1^j \quad (8)$$

- The total discharged contaminant flow rate is equal to the sum of contaminant mass loads of each process j :

$$\sum_m wrd_{i>1}^m + \sum_j wd_{i>1}^j = \sum_j M_{i>1}^j \quad (9)$$

Equations (10) and (11) introduce two new notations for the total inlet and outlet flow rates in a given process j in order to make the understanding of the next constraints easier:

$$wp_i^j + \sum_k wp_i^{k \rightarrow j} + \sum_m wrp_i^{m \rightarrow j} = wp_{in,i}^j \quad (10)$$

$$\sum_k wp_i^{j \rightarrow k} + \sum_m wrp_i^{j \rightarrow m} + wd_i^j = wp_{out,i}^j \quad (11)$$

Given this set of mass balances equations, constraints on contaminant concentrations are added to the mathematical problem. Each process is limited with inlet and outlet contaminant concentrations following these inequalities (for a process j):

$$wp_{in,i>1}^j \leq Cmax_j^{in} \times wp_{in,1}^j \quad (12)$$

$$wp_{out,i>1}^j \leq Cmax_j^{out} \times wp_{out,1}^j \quad (13)$$

In the same way, the post-regeneration concentration is fixed and gives birth to the equality (14).

$$wr_{out,i>1}^m = Cr_m^{out} \times wr_{out,1}^m \quad (14)$$

The addition of the constraint (13) is not without repercussions because it represents mass balances at splitters. Consequently, the output streams of a given process must have the same pollutant concentration and this assumption is mathematically conveyed for the outlet of a process j as:

$$wp_{i>1}^{j \rightarrow k} - Cmax_j^{out} \times wp_1^{j \rightarrow k} = wrp_{i>1}^{j \rightarrow m} - Cmax_j^{out} \times wrp_1^{j \rightarrow m} = wd_{i>1}^j - Cmax_j^{out} \times wd_1^j \quad (15)$$

And in the same way, for the regeneration unit m :

$$wr_{i>1}^{m \rightarrow n} - Cr_m^{out} \times wr_1^{m \rightarrow n} = wrp_{i>1}^{m \rightarrow j} - Cr_m^{out} \times wrp_1^{m \rightarrow j} \quad (16)$$

However, these equalities hide an important condition. Indeed, if the mass flow of water is null for one stream, this stream does not exist, what is traduced by the logic condition (17):

$$\text{if } wp_1^{j \rightarrow k} = 0 \text{ then } wp_{i>1}^{j \rightarrow k} = 0 \quad (17)$$

It changes Equation (15) in Equation (18), if the process j does not distribute water to another process k , it implies that, for instance:

$$0 = wrp_{i>1}^{j \rightarrow m} - Cmax_j^{out} \times wrp_1^{j \rightarrow m} = wd_{i>1}^j - Cmax_j^{out} \times wd_1^j \quad (18)$$

Thus,

$$wrp_{i>1}^{j \rightarrow m} = Cmax_j^{out} \times wrp_1^{j \rightarrow m} \quad (19)$$

The former demonstration changes Equation (19) into the equality (19), and thus, implies that outlet concentrations are equal to the maximal value $Cmax_j^{out}$ for each process of the network. This condition does not compromise the guarantee of optimality because written like this, the problem check all the "necessary optimality conditions" for a single contaminant water allocation problem (Savelski and Bagajewicz, 2000). These authors give several theorems among which:

- **Theorem 2:** *If a solution of the WAP problem is optimal, then the outlet concentration of a head process is equal to its maximum or an equivalent solution with the same overall fresh water exists in which the concentration is at its maximum".*

- **Theorem 3:** *If a solution of the WAP problem is optimal, then the outlet concentration of an intermediate process reaches its maximum or an equivalent solution with the same overall fresh water exists in which the concentration is at its maximum".*

- **Theorem 4:** *If the solution of the WAP problem is optimal, then the outlet concentration of a terminal process is equal to its maximum or an equivalent solution with the same overall fresh water consumption exists"*

In a water network, since all processes are either head, intermediate or terminal processes, the constraint (18) agrees with the necessary optimality conditions proved by Savelski and Bagajewicz (2000). At this stage of the modelling process, the problem is linear and can be solved with a Linear Programming (LP).

Nevertheless, in order to evaluate the network complexity, a binary variable is allocated to each flow, what changes the problem into a MILP form. These variables are added in the program with the help of a Big-U constraint as (U has to be bigger than any water flow rate of the plant):

$$Wp_1^{j \rightarrow k} \leq yp^{j \rightarrow k} \times U \quad (20)$$

In the particular case of an EIP, these equations are the same for each company included in the park: in the following example the EIP involves a company A containing processes from 1–5, a company B with processes 6–10 and a company C with processes 11–15. The regeneration units are numbered from 1–3, respectively for the three companies. However, a global EIP may include the following rules as constraints: between each company, only one flow needs to be exchanged in one way. This condition is necessary in order to simplify the final EIP. However, this number can be changed if it is permitted by the abilities of the park as the geographic layout. In order to let the reader appreciate this choice, Section 3.6 evaluates economic impacts of connections. It is demonstrated that external connections (meaning between companies) are much expensive than internal ones. For instance; the company A should have only two connections with the company B (one from A to B (21) and one from B to A (22)):

$$\sum_{i=1}^5 \sum_{j=6}^{10} yp^{i \rightarrow j} + \sum_{j=6}^{10} yrp^{1 \rightarrow j} + \sum_{i=1}^5 ypr^{i \rightarrow 2} = 1 \quad (21)$$

$$\sum_{i=1}^5 \sum_{j=6}^{10} yp^{j \rightarrow i} + \sum_{j=6}^{10} yrp^{j \rightarrow 1} + \sum_{i=1}^5 ypr^{2 \rightarrow i} = 1 \quad (22)$$

3.4. Multiobjective optimization

In order to solve this linear problem, objective functions F_1 (fresh water flow rate at the network entrance) and F_2 (water flow rate at inlets of regeneration units) have to be minimized while the third one F_3 (number of connections into the network) is considered as an equality constraint. One can wonder why a biobjective optimization (F_1, F_2) is performed instead of a mono-objective one by minimizing a cost function. In fact, by implementing a biobjective optimization a Pareto front is obtained instead of a single solution as in the monoobjective case. Let us recall that a Pareto front is the set of efficient (non-dominated) solutions for a multi-objective problem; this is an equilibrium curve, where a given solution cannot be improved without degrading at least another

one. Consequently, it is better to let F_1 and F_2 as two separate objectives in order to construct Pareto fronts. Indeed, a cost value can change in function of the capacities or yet the geographic situation of the company. In this multiobjective optimization framework all the treated results are presented first and a tool for decision aid is then proposed and used. The advantage of this method is to have universal results that can be treated with several tools. Furthermore, F_3 is deliberately estimated in terms of connections number because if a cost is attributed, the objective function cannot stay linear. According to Sieniutycz and Jezowski (2009), the cost of connections is linked to the associated flow rate according a power law (23). Thereby, the problem is changed into a nonlinear form. It is worth noting that the results can be evaluated in terms of cost in a post-optimization stage.

$$C = \gamma \times (W_1^j)^\mu \quad (23)$$

Where C is the cost of a connection linked to the flow rate W_1^j ; μ and γ are coefficients depending on the parameters of the network studied (flow rates, type of liquid circulating...).

The optimization variables are the various flow rates (continuous variables) and the existence of connections (binary variables). The additional set of constraints is given by the modelling equations. The problem solutions are displayed in the form of a Pareto front, so a comparison strategy has to be defined for identifying "good" solutions among the ones reported on the front.

3.5. Comparison strategy

In what follows, internal connections refer to connections between processes of the same company and external connections are related to connections coming from or going towards other companies. By supposing constant distances between companies, it is assumed that for each external connection, the cost for each company is divided by two. For EIPs involving an interceptor for sharing regeneration units, the connections between a given company and the interceptor are external connections. Thus, the equivalent number of connections ENC for a given company, which reflects the piping and pumping costs and the associated infrastructure, is given by:

$$\text{ENC} = \text{number of internal connections} + 0.5 \times \text{number of external connections} \quad (24)$$

Another economic indicator, the Global Equivalent Cost (GEC) in water flow rate, is defined in this study. This cost is expressed as an equivalent of water flow rate in T/h. For comparison purposes, we could use the prices of fresh water, of regenerated water and of post-treatment in the waste. However, these prices are strongly linked to the country and even to regions of this state.

$$\text{GEC} = F_1 + R + W \quad (25)$$

where F_1 is defined above, R and W are the contributions of regenerated and waste waters, with:

$$R = \alpha \times F_2 \quad \text{and} \quad W = \beta \times F_w \quad (26)$$

where F_w is the waste water flow rate.

Combining relations (25) and (26) leads to the following relation:

$$\text{GEC} = F_1 + \alpha \times F_2 + \beta \times F_w \quad (27)$$

In the previous relations, α depends on the type of regeneration unit (see Table 1) and $\beta = 5.625$ according to Bagajewicz and Faria (2009).

Table 1
Values of α according to types of regeneration units.

Regeneration type	Outlet concentration (ppm)	α value
I	50	0.375
II	20	1.75
III	5	3.125

After the multiobjective optimization step, the different solutions are discriminated by performing a Pareto sort on the couples (GEC, ENC) for each company.

3.6. Economic impact of connections

The economic impact of the number of connections on the choice of a particular solution is analyzed from the following example: a company involving five processes, with a regeneration unit of type I and eight connections. The same flow (23.25 T h^{-1}) is assumed in each pipe, and the piping cost is computed from Chew et al. (2008) with a mean length of internal pipes of 50 m, a fractional interest rate of 5%, a period of 5 years and a fresh water cost of 0.1 €/T (cost of river water). The ratio (piping cost/water cost) is 14%. Even if the network exhibits simplicity of implementation, this example shows that there is a real economic interest in optimizing the number of connections. Note that when EIPs are considered, the part due to external connections which are much longer (there is at least a factor 10) than the internal ones, significantly increases the ratio (piping cost/water cost).

4. Design of water network problem

4.1. Problem formulation

For the example presented below, the number of connections in the network is defined in the range [11–120] representing the lowest (respectively the highest) number of possible connections in the network. This water allocation problem consists in solving the biobjective problem (F_1, F_2) under the constraint F_3 , fixed to a given value in the previous range. The multiobjective method recalled in Section 3.4 and based on the ϵ -constraint two-phase strategy (Mavrotas, 2009) is implemented. During the first phase, the first objective (F_1) is minimized alone, while the second one (F_2) is introduced as a bounding constraint. The second objective is minimized in the second step, where the first one can vary in an interval for which the optimal value obtained in the first phase is the median. When the solutions obtained in the two phases are identical, they are inserted in the Pareto front.

This example involving ten processes, one regeneration unit of type I (see Table 1) and one contaminant, was already proposed by Bagajewicz and Savelski (2001), the corresponding limiting process data are shown in Table 2 and the outlet regeneration concentration is fixed at 5 ppm. The corresponding MILP involves 143 binary variables related to connections, 332 continuous variables and 351 constraints.

4.2. Theoretical results

The biobjective optimization was performed for different values of the connection number F_3 in the range [11, 120]. The constraint (18) imposes to minimize the overall fresh water consumption. Hence, for several ranges of F_2 , the fresh water consumption is minimized in order to have one optimal solution for each range of F_2 and for a given value of F_3 . Starting from $F_3 = 11$, all the possible values for F_3 were tested. When F_3 is greater or equal to 19, all the

Table 2

Process data for the water allocation problem.

Process	$C_{max_j}^{in}$ (ppm)	$C_{max_j}^{out}$ (ppm)	M_j^i (g/h)
1	25	80	2000
2	25	90	2880
3	25	200	4000
4	50	100	3000
5	50	800	30000
6	400	800	5000
7	400	600	2000
8	0	100	1000
9	50	300	20000
10	150	300	6500

fronts are superimposed on the same straight line. For example, the Pareto fronts corresponding to $F_3 = 11, 12, 19$ and 120 are reported in Fig. 2. Feng et al. (2007) show the linearity of the Pareto fronts for this particular problem. The values obtained for this example are identical with the ones reported in the literature (Bagajewicz and Savelski, 2001; Feng et al., 2008; Huang et al., 1999). Thus the network mathematical formulation and the optimization procedure are validated.

4.3. Choice of the best feasible network

The solutions displayed in Fig. 2 are only theoretical results because in some cases, connections with quasi-null flow rates may exist. Obviously this type of solution cannot be considered in practice. Indeed, it is generally admitted (Bagajewicz and Savelski, 2001) that networks involving flows lower than 2 T h^{-1} cannot be used in practice because they force the user using very small pipes (with a diameter of about 1 inch). These pipes are not economically profitable regarding their investment cost. From the theoretical study, "good" solutions on an industrial point of view, combining moderate GEC, few connections and non null flow rates

in the connections have to be defined. The minimum value of GEC was studied vs. the connection numbers, and the best solution (GEC = 619 T h^{-1}) is obtained with 17 connections and corresponds to: $F_1 = F_w = 10 \text{ T h}^{-1}$ and $F_2 = 177 \text{ T h}^{-1}$. The flowsheet of the proposed solution is given in Fig. 3 (connections are numbered in brackets; connections going to the waster are not numbered). Other solutions with higher connection numbers can be also identified, but are topologically more complicated.

4.4. Discussion

From this example, the following conclusions can be emphasized: (i) the solutions provided by the Pareto fronts are only theoretical results; ii) further investigations based on the global equivalent cost (GEC) and the connection number have to be performed for identifying the best practical solution; iii) since it does not requires any initialization phase and can tackle large scale problems, this MILP approach can be implemented to optimize EIPs, where the problems are larger in terms of numbers of variables and constraints.

5. EIPs for managing industrial waters

5.1. Problem formulation

The DWN procedure is now extended to the design of EIPs and illustrated by the example proposed by Olesen and Polley (1996). The industrial pool involves three companies, each one including five processes; the data are displayed in Table 3.

The three companies decide to constitute an EIP for managing their used waters. Three scenarios are considered: EIP without regeneration unit, EIP where each company owns its regeneration unit and EIP where the three companies share regeneration unit(s). Three possible regeneration units (see Table 1) can be chosen under two kinds of constraints: limited or unlimited number of

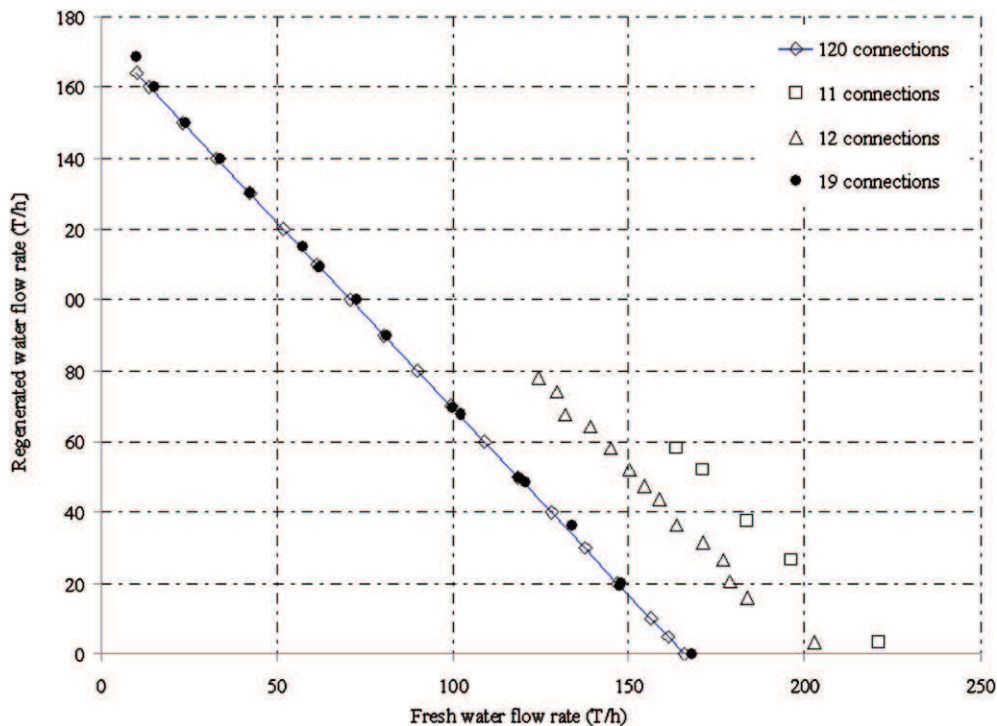

Fig. 2. Theoretical solutions for the water allocation problem giving the regenerated water flow rate and the fresh water flow rate for each network.

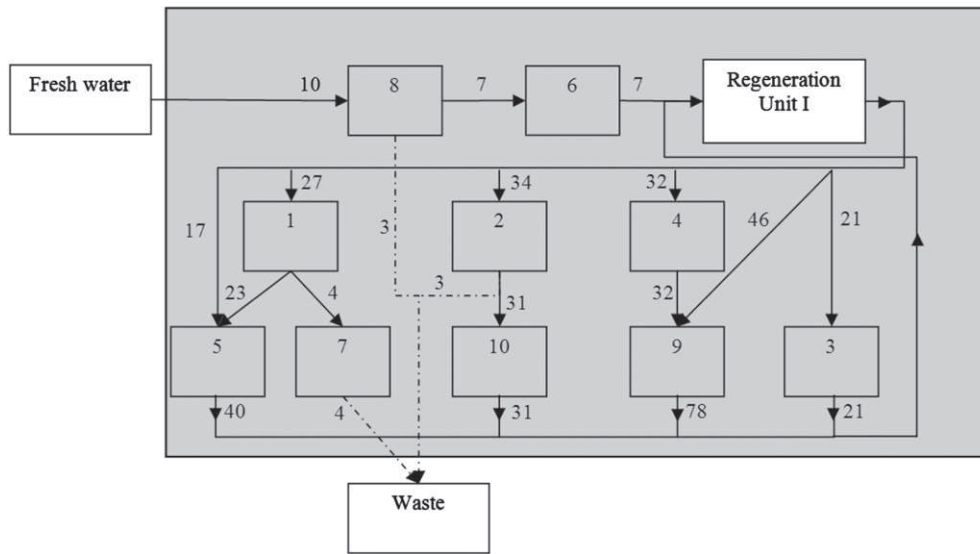

Fig. 3. Best solution for the water allocation problem (flows are in T/h).

Table 3
Process characteristics for the EIP.

Process	Company	Contaminant flow rate (Kg/h)	Maximal inlet concentration (ppm)	Maximal outlet concentration (ppm)
1	A	2	0	100
2		2	50	80
3		5	50	100
4		30	80	800
5		4	400	800
6	B	2	0	100
7		2	50	80
8		5	80	400
9		30	100	800
10		4	400	1000
11	C	2	0	100
12		2	25	50
13		5	25	125
14		30	50	800
15		15	100	150

connections, same or different gains for each company. The objective is then to identify the best strategy for each company so as to minimize the global equivalent cost in fresh water and the number of connections in the network. Compared to some basic cases, a solution will be retained only if the gain in GEC for each

Table 4
Characteristics of the cases treated.

Superstructure	Cases	Description of the configuration
Without EIP	Case 1	Companies are considered individually and are not included in the EIP
	Case 2	Connections are not included as an objective, F_3 is free
EIP without regeneration unit	Case 3	Connections are restricted to 21, the minimum feasible
	Case 4	Connections are restricted to 21 and each company needs to have the same gain
	Case 5	Companies are considered individually to choose their own regeneration unit
EIP with individual regeneration units (direct integration scheme)	Case 6	Connections are not included as an objective, F_3 is free
	Case 7	Connections are restricted to 26, the minimum feasible
	Case 8	Connections are restricted to 26 and each company needs to have the same gain
	Case 9	EIP with regeneration unit of type I
EIP with a shared regeneration unit (indirect integration scheme)	Case 10	EIP with regeneration unit of type I and external connections are restricted to 2
	Case 11	EIP with an interceptor containing regenerations of type I, II and III
	Case 12	Case 11 with connections restricted to 26 and the same gain for each company
	Case 13	Case 11 with connections restricted to 31 and the same gain for each company

Summarization of the several cases treated in Section 6.

company is positive, and for two equivalent gains, the solution with a minimum ENC will be selected. Table 4 explains the several cases which are explored all along the Section 5. The results are displayed in Table 5, where only the cases giving a positive gain in GEC compared to the basic case for the three companies are reported. The rejected solutions are reported in Table 6 and will not be discussed in the following sub-sections.

5.2. Basic case: companies without EIP and without regeneration unit (case 1)

This preliminary study (**case 1**) concerns the individual optimization of the water network for each company without considering the EIP, according to objectives F_1 and F_3 (since there is no regeneration unit, the objective F_2 is not taken into account). The results of this monobjective optimization problem are displayed in Table 5, and for the sake of illustration, the network flowsheet for company A with six connections is displayed in Fig. 4.

5.3. EIP without regeneration unit (cases 2–4)

The three companies which have no regeneration unit constitute an EIP without regeneration unit, but by allowing their used waters to be treated in the two other companies and receiving used

Table 5

Results for the EIP (only cases with positive gains are reported).

Case	F_1 T/h	F_w T/h	F_2 T/h	GEC T/h	Gain % Case 1	Gain % Case 5	Int. + Ext. conn
A case 1	98.3	98.3	xxx	651	xxx	xxx	6
A case 4	102.8	92.6	xxx	623	4.3	Xxx	6
A case 5	20	20	166	195	70.0	xxx	8
A case 8	20	15.2	166.6	168	74.2	13.8	7
A case 13	20	19	166	188	71.1	3.6	9
B case 1	54.6	54.6	xxx	362	xxx	xxx	8
B case 4	45	53.6	xxx	346	4.3	xxx	6
B case 5	20	20	66.7	157	56.6	xxx	8
B case 8	20	12	128	135	62.4	13.8	9
B case 13	20	19	67	151	76.8	3.6	12
C case 1	190	190	xxx	1259	Xxx	xxx	7
C case 4	180	182	xxx	1204	4.3	xxx	9
C case 5	20	20	192	469	62.7	xxx	10
C case 8	20	32.7	114	404	67.9	13.8	10
C case 13	20	22	213	452	30.6	3.6	10
Total case 1	343	343	xxx	2272	xxx	xxx	21
Total case 4	328	328	xxx	2173	4.3	xxx	21
Total case 5	60	60	426	821	63.9	xxx	26
Total case 8	60	60	409	708	68.8	13.8	26
Total case 13	60	60	446	791	65.2	3.6	31

waters from the two other companies, as shown in Fig. 5 (do not take into account the dotted lines, nor italic parts). Three cases are considered: **case 2** corresponds to an unlimited number of connections in the EIP; in **case 3** the number of connections is assumed to be restricted to 21, which is the best solution found in **case 1** (6 for company A, 8 for company B and 7 for company C, see Table 4); in **case 4** the number of connections is also limited to 21 and the same relative gain is assumed for each company.

The results are displayed in Table 5, where the gains are computed by using **case 1** as a basis. Only the **case 4** (same relative

gain in GEC for each company, and also the same number of connections, 21), gives a positive gain (4.3%) for each company. The new flowsheet for company A in the **case 4** is depicted in Fig. 6, where external connections are numbered in brackets, italic.

5.4. EIP with one regeneration unit per company (direct integration, cases 5–8)

Each company is now equipped with its own regeneration unit chosen among the three types above mentioned. In the basic **case 5**, the DWN problem is solved for each company without considering the EIP in order to determine the best regeneration unit chosen among the three types listed in Table 1. From this multiobjective optimization study (objectives F_1 , F_2 and F_3), the best solution is obtained when companies A and B choose regeneration unit I, and company C, regeneration unit II. These solutions are given by the median points of the Pareto fronts (F_1 , F_2) for the minimal values of F_3 , and the results are displayed in Table 5.

Then the three companies constitute an EIP without common regeneration unit, but by allowing their polluted streams to be treated either in their own regeneration unit, or in the two other companies (see Fig. 5, do not take into account the dotted lines). Three new cases are considered: **case 6** with no limitation on the number of connections, **case 7** with the same number of connections less equal than the best solution of **case 5** (26, i.e. 8 for

Table 6

Rejected solutions.

Rejected solution	Gain % vs. Case 1	Gain % vs. Case 5
C case 2	-8.2	xxx
B case 3	-10.5	xxx
C case 3	-2.6	xxx
A case 6	xxx	-10.2
B case 6	xxx	-61.8
A case 7	xxx	-74.9
A case 9	xxx	-144.6
B case 10	xxx	-233.1
B case 11	xxx	-138.2
A case 12	xxx	-7.7
B case 12	xxx	-7.7
C case 12	xxx	-7.7

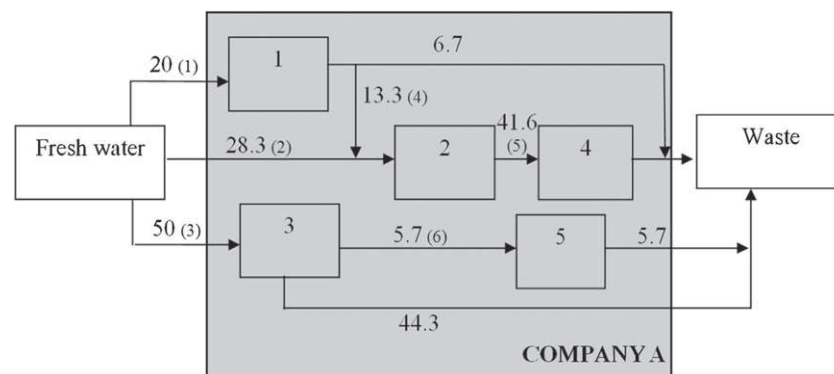
**Fig. 4.** Network for company A with six connections (case 1) (flows are in T/h, numbers of pipes are in brackets, dash lines are connections going to the discharge).

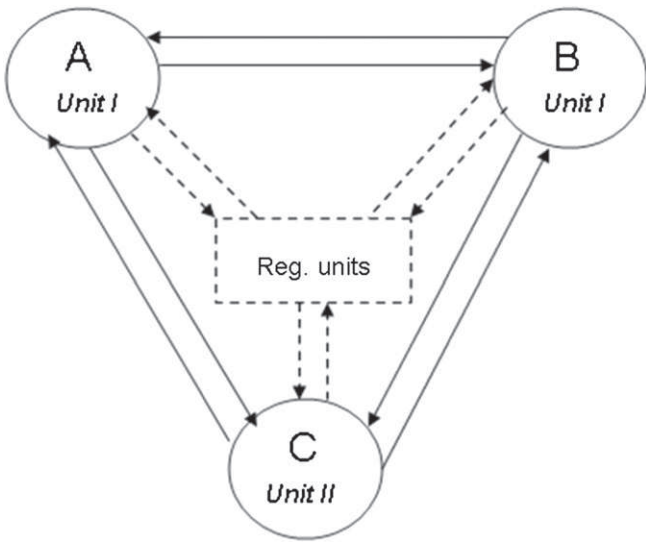

Fig. 5. Representation of an EIP for the three companies (from Chew et al., 2008) (straight lines: direct integration, dash lines: indirect integration).

companies A and B and 10 for company C, see Table 5), **case 8** with the same relative gain in GEC (compared with case 5) for each company, and also the number of connections less equal to 26.

The results are displayed in Table 5, where the gains in GEC are computed by using **case 1**, then **case 5** as a basis. **Case 5** being the basis of comparison, only **case 8** provides positive a positive gain for each company (same gain of 13.8%, number of connections equal to 26); it is the best solution for the EIP. The new flowsheet for company A in this solution is depicted in Fig. 7. Compared with **case 1**, regeneration units (**cases 5 and 8**) provide very interesting gains (63.9 and 68.8%). The economic interest of regeneration units is evident. It may be interpreted that Table 5 exhibits inconsistent results between waste and regenerated flows for cases B8, (increase (decrease) in waste and increase (decrease) in regeneration). This is yet not the case since included into an EIP a company may reject or regenerate waters coming from other companies.

5.5. EIP with a common regeneration unit (indirect integration, cases 9–13)

The three companies have now an interceptor containing shared regeneration unit(s) and connections between them (see Fig. 5, do not take into account the italic parts). Five cases are evaluated. **Case 9** corresponds to an unlimited number of connections and a shared

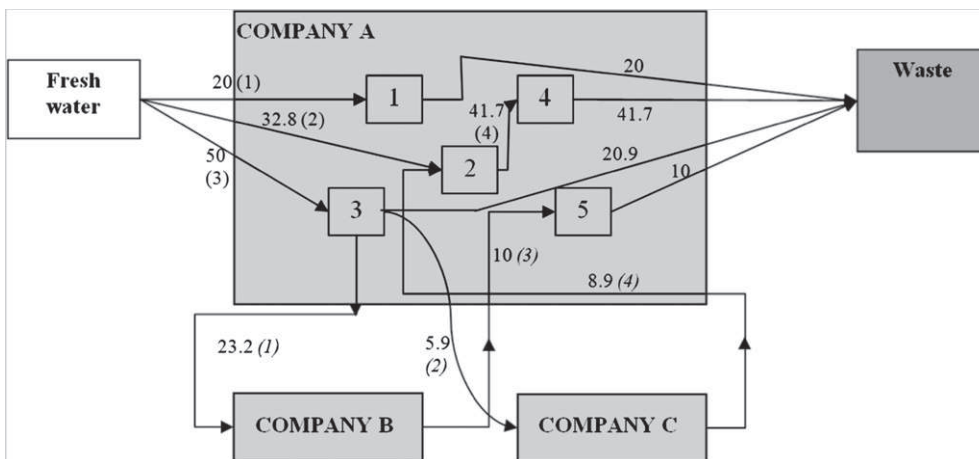

Fig. 6. Network for company A (case 4) (flows are in T/h, numbers of pipes are in brackets, external connections are in italic).

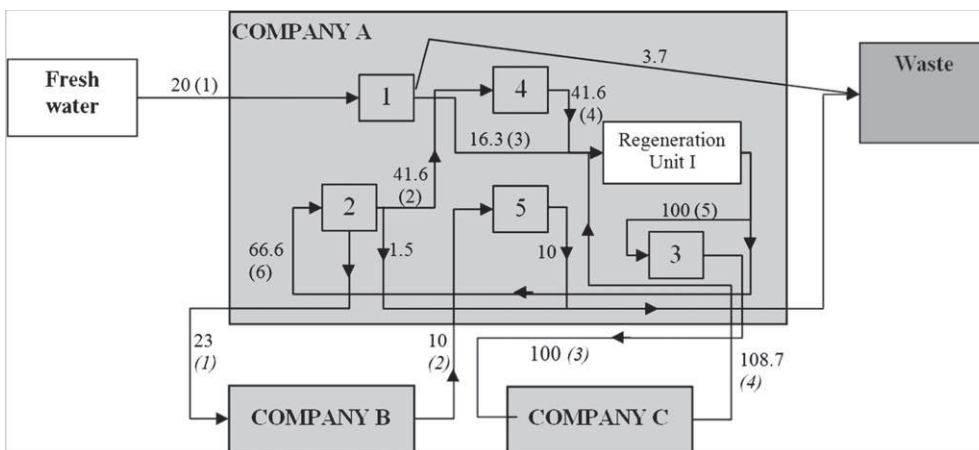

Fig. 7. Network for company A (case 8) (flows are in T/h, numbers of pipes are in brackets, external connections are in italic).

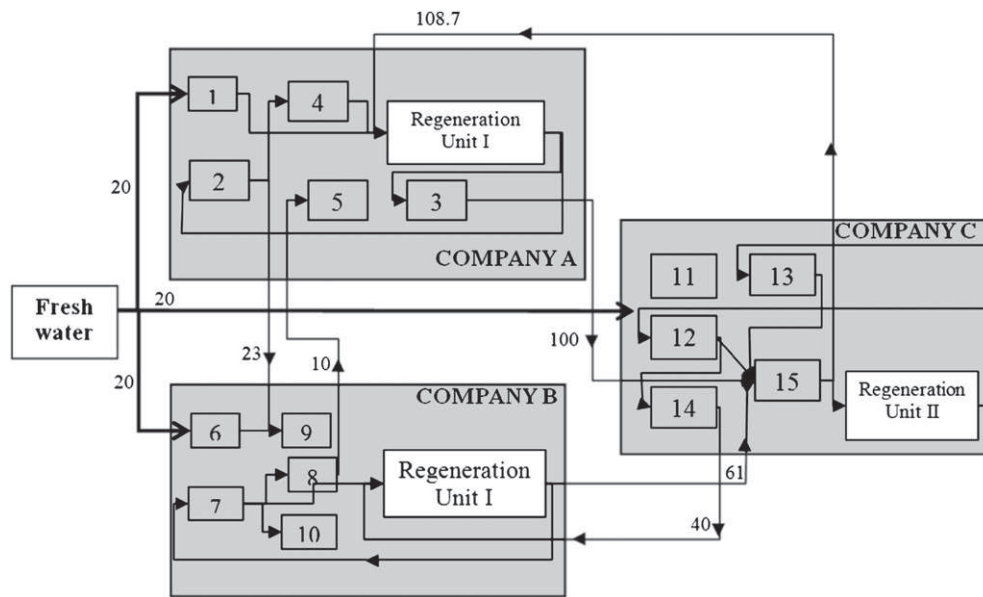

Fig. 8. EIP solution (case 8, flows are in T/h).

regeneration unit of type I. In **case 10**, the number of external connections between companies is limited at two pipes and a shared regeneration unit of type I is used. **Case 11** concerns an EIP involving an interceptor containing the three types of regeneration units, each company can choose two units among the three possible ones, and unlimited number of connections. **Case 12** is deduced from **case 11** by restricting the total number of connections to 26 (as in **cases 7** and **8**) and assuming the same gain for each company (compared with **case 5**), and finally in **case 13**, the same gain for each company is also imposed but the total number of connections is arbitrarily increased to 31.

Compared with **case 5**, only **case 13** gives a positive gain for each company (3.6%), but compared with the best solution, **case 8**, found in the previous example the gain for each company is negative (-11.7%). In conclusion, the EIP involving an interceptor is not economically profitable.

5.6. Discussion

This study shows first that regeneration units yield very significant gains, and second that these gains can be increased again by a direct integration into an EIP. Finally the a priori most attractive EIP with an indirect integration (interceptor sharing regeneration units) does not succeed in improving the previous solution. The best EIP (**case 8**) is shown in Fig. 8 (the connections to the waste are not reported), and the flowsheet of company A in this EIP is depicted in Fig. 7.

6. Computational aspects

For all the cases, the problem dimensions are displayed in Table 7. When passing from a DWN problem (**case 1**) to EIP problems, the dimensions strongly increase. However due to the linear formulation this increase has not much influence either on the problem resolution, or on the CPU time (the computations were carried on an Intel Duo Core 2.53 GHz, RAM 3.45 Go). The MILP problem is solved with the solver CPLEX 11.2.1 of the GAMS package.

Table 7

Problem dimensions and CPU times.

Problem	Continuous variables	Integer variables	Constraints	CPU time (s)
Case 1	173	47	214	0.063
Case 2–4	836	255	900	0.109
Case 5–8	1164	357	1312	0.140
Case 9–13	1164	357	1319	0.250

7. Conclusions

In the first part of the paper, a methodology taking into account only the single contaminant case is implemented. A MILP formulation is used to solve the problem. Biobjective optimization of the fresh water flow rate at the network entrance and the water flow rate at regeneration unit inlets, parameterized by the number of connections in the network, is carried out. A strategy based on the global equivalent cost (GEC) and equivalent number of connections (ENC) allows identifying the best practical solution combining moderate GEC, few connections and non null flow rates in the connections, among the theoretical ones displayed on Pareto fronts.

This MILP approach is then implemented to optimize an EIP involving three companies. From several analyzed scenarios, it can be deduced that the best solution is an EIP with direct integration: each company owns its regeneration unit, same gain for each company and restricted number of connections. Compared with the case of companies without EIP and without regeneration unit, the gain in GEC is 68.8%, and compared with the case of companies without EIP, but with their own regeneration unit, the supplementary gain in GEC for each company is 13.8%. This study shows first that regeneration units yield very significant gains, and second that these gains can be increased again by a direct integration into an EIP. Finally, the a priori most attractive EIP with an indirect integration (interceptor sharing regeneration units) does not succeed in improving the previous solution. Using different criteria (GEC, connections number, non null flow rates in the connections), a best practical solution is defined for each case. Moreover, after optimisation, the gain for each case is calculated and each company in the EIP can decide to connect to the EIP or not. Of course, the

calculated gain is different in each case, so it is easier to choose the type of connections. Due to the MILP problem, it is possible to add some technical constraints without any size limitations.

Few studies were realized on the technical constitution of an EIP, and even less in the framework of multiobjective optimization, while the problem is by nature a multiobjective one, combining economical and ecological objectives. Furthermore, in a recent study Sakr et al. (2011) identify seven success and limiting factor for EIPs development. The present study comes within the second one "Added economic value", and fills partially the existing gap in the literature.

References

- Alexander, B., Barton, G., Petrie, J., Romagnoli, J., 2000. Process synthesis and optimisation tools for environmental design: methodology and structure. *Comp. Chem. Eng.* 24, 1195–1200.
- Allenby, B., 2006. The ontologies on industrial ecology. *Prog. Ind. Ecol. Int. J.* 3 (1–2), 28–40.
- Aviso, K.B., Tan, R.R., Culaba, A.B., 2010a. Designing eco-industrial water exchange networks using fuzzy mathematical programming. *Clean Technol. Environ. Policy* 12, 353–363.
- Aviso, K.B., Tan, R.R., Culaba, A.B., Cruz Jr., J.B., 2010b. Bi-level fuzzy optimization approach for water exchange in eco-industrial parks. *Process Saf. Environ. Prot.* 88, 31–40.
- Baas, L., 2006. Cleaner production systems in the context of needed partners and policies at the micro, meso and macro level. UNIDO Cleaner Production Expert Group Meeting, Baden, Austria, pp. 29–31 October 2006.
- Baas, L., Boons, F., 2004. An industrial ecology project in practice: exploring the boundaries of decision-making levels in regional industrial systems. *J. Clean Prod.* 12, 1073–1085.
- Bagajewicz, M., Faria, D.C., 2009. On the appropriate architecture of the water/wastewater allocation problem in process plants. *Comput. Aided Chem. Eng.* 26, 1–20.
- Bagajewicz, M., Savelski, M., 2001. On the use of linear models for the design of water utilization systems in process plants with a single contaminant. *Chem. Eng. Res. Des.* 79, 600–610.
- Boix, M., Montastruc, L., Pibouleau, L., Azzaro-Pantel, C., Domenech, S., 2010. Multiobjective optimization of industrial water networks with contaminants. *Comput. Aided Chem. Eng.* 28, 859–864.
- Boix, M., Montastruc, L., Pibouleau, L., Azzaro-Pantel, C., Domenech, S., 2011. A multiobjective optimization framework for multicontaminant industrial water network design. *J. Environ. Manage.* 92, 1802–1808.
- Côté, R., Cohen-Rosenthal, E., 1998. Designing eco-industrial parks: a synthesis of some experiences. *J. Clean Prod.* 6, 181–188.
- Chertow, M.R., 2000. Industrial symbiosis: literature and taxonomy. *Annu. Rev. Energy Env.* 25, 313–337.
- Chertow, M.R., 2007. Uncovering" industrial symbiosis. *J. Ind. Ecol.* 11, 11–30.
- Chew, I.M.L., Tan, R.R., Ng, D.K.S., Foo, D.C.Y., Majozi, T., Gouws, J., 2008. Synthesis of direct and indirect interplant water network. *Ind. Eng. Chem. Res.* 47, 9485–9496.
- Chew, I.M.L., Tan, R.R., Foo, D.C.Y., Chiu, A.S.F., 2009. Game theory approach to the analysis of interplant water integration in an eco-industrial park. *J. Clean Prod.* 17, 1611–1619.
- Chew, I.M.L., Foo, D.C.Y., Ng, D.K.S., Tan, R.R., 2010a. Flowrate targeting algorithm for interplant resource conservation network. Part 1: unassisted integration scheme. *Ind. Eng. Chem. Res.* 49, 6439–6455.
- Chew, I.M.L., Foo, D.C.Y., Tan, R.R., 2010b. Flowrate targeting algorithm for interplant resource conservation network. Part 2: assisted integration scheme. *Ind. Eng. Chem. Res.* 49, 6456–6468.
- Chew, I.M.L., Thillaivarna, S.L., Tan, R.R., Foo, D.C.Y., 2010c. Analysis of inter-plant water integration with indirect integration schemes through game theory approach: pareto optimal solution with interventions. *Clean Technol. Environ. Policy* 13, 49–62.
- Conover, W.R., 1918. Salvaging and utilizing wastes and scrap in industry. *Ind. M.* 55, 6, 449–451.
- de Faria, D.C., de Souza, A.A.U., Guelli Ulson de Souza, S.M.A., 2009. Optimization of water networks in industrial processes. *J. Clean Prod.* 17, 857–862.
- Dunn, R.F., Wenzel, H., 2001. Process integration design methods for water conservation and wastewater reduction in industry. *Clean. Prod. Processes* 3, 307–318.
- El-Halwagi, M.M., 1997. Pollution Prevention through Process Integration—Systematic Design Tools. Academic Press, CA, USA.
- El-Halwagi, M.M., Gabriel, F., Harell, D., 2004. Rigorous graphical targeting for resource conservation via material recycle/reuse networks. *Ind. Eng. Chem. Res.* 42, 4319–4328.
- Erol, P., Thöming, J., 2005. ECO-design of reuse and recycling networks by multi-objective optimization. *J. Clean Prod.* 13, 1492–1503.
- Feng, X., Bai, J., Zheng, X.S., 2007. On the use of graphical method to determine the targets of single contaminant regeneration recycling water systems. *Chem. Eng. Sci.* 62, 2127–2138.
- Feng, X., Bai, J., Wang, H.M., Zheng, X.S., 2008. Grass-roots design of regeneration recycling water networks. *Comp. Chem. Eng.* 32, 1892–1907.
- Frosh, R.A., Gallopoulos, N.E., 1989. Strategies for manufacturing. *Sci. Am.* 261, 144–152.
- Galan, B., Grossmann, I.E., 1998. Optimal design of distributed wastewater treatment networks. *Ind. Eng. Chem. Res.* 37, 4036–4048.
- Geng, Y., Hengxin, Z., 2009. Industrial park management in the Chinese environment. *J. Clean Prod.* 17, 1289–1294.
- Gibbs, D., Deutz, P., 2005. Implementing industrial ecology? Planning for eco-industrial parks in the USA. *Geoforum* 36, 452–464.
- Gibbs, D., Deutz, P., 2007. Reflections on implementing industrial ecology through eco-industrial park development. *J. Clean Prod.* 15, 1683–1695.
- Giurco, D., Bossilkov, A., Patterson, J., Kazaglis, A., 2010. Developing industrial water reuse synergies in Port Melbourne: cost effectiveness, barriers and opportunities. *J. Clean Prod.* 19, 867–876.
- Gomes, F.S., Queiroz, E.M., Pessoa, F.L.P., 2007. Design procedure for water/wastewater minimization: single contaminant. *J. Clean Prod.* 15, 474–485.
- Gussow, D., Meyers, J., 1970. *Industrial Ecology*, vol. 1.
- Hallale, N., Fraser, D.M., 2000. Super-targeting for mass exchange networks. Part I: targeting and design techniques. *Trans. Inst. Chem. Eng.* 78, 202–216.
- Heeres, R.R., Vermeulen, W.J.V., de Walle, F.B., 2004. Eco-industrial parks initiatives in the USA and the Netherlands: first lessons. *J. Clean Prod.* 12, 985–995.
- Hoffman, C., 1971. The Industrial Ecology of Small and Intermediate-sized Technical Companies: Implications for Regional Economic Development. Report Prepared for the Economic Development Administration COM-74-10680. Texas University, USA.
- Huang, C.H., Chang, C.T., Ling, H.C., Chang, C.C., 1999. A mathematical programming model for water usage and treatment network design. *Ind. Eng. Chem. Res.* 38, 2666–2679.
- Jacob, J., Viviant, C., Houle, H.F., Paris, J., 2002. Analysis and optimization of water networks in pulp and paper manufacturing: pinch technology. *Pulp Pap. Can.* 103, 24–27. In French.
- Karuppiah, R., Grossmann, I.E., 2008. Global optimization of multiscenario mixed integer nonlinear programming models arising in the synthesis of integrated water networks under uncertainty. *Comp. Chem. Eng.* 32, 145–160.
- Kim, S.H., Yoon, S.-G., Chae, S.H., Park, S., 2010. Economic and environmental optimization of a multi-site utility network for an industrial complex. *J. Environ. Manage.* 91, 690–705.
- Klemes, J., Friedler, F., Bulatov, I., Varbanov, P., 2010. Sustainability in the Process Industry – Integration and Optimization. McGraw-Hill, New York, USA.
- Kumaraprasad, G., Muthukumar, K., 2009. Design of mass exchange network and effluent distribution system for effective water management. *J. Clean Prod.* 17, 1580–1593.
- Lavric, V., Iancu, P., Plesu, V., 2005. Genetic algorithm optimisation of water consumption and wastewater network topology. *J. Clean Prod.* 13, 1405–1415.
- Lim, S.R., Park, J.M., 2008. Cooperative water network system to reduce carbon footprint. *Environ. Sci. Technol.* 42, 6230–6236.
- Linnhoff, B., Vredevelde, R., 1984. Pinch technology has come of age. *Chem. Eng. Prog.*, 33–40.
- Liu, C., Zhang, K., Zhang, J., 2010. Sustainable utilization of regional water resources: experiences from the Hai Hua ecological industry pilot zone (HHEIPZ) project in China. *J. Clean Prod.* 18, 447–453.
- Liwarska-Bizukojc, E., Bizukojc, M., Marcinkowski, A., Doniec, A., 2009. The conceptual model of an eco-industrial park based upon ecological relationships. *J. Clean Prod.* 17, 732–741.
- Lovelady, E.M., El-Halwagi, M.M., 2009. Design and integration of eco-industrial parks for managing water resources. *Environ. Prog. Sustain. Energy* 28, 265–272.
- Manan, Z.A., Wan Alwi, S.R., Ujang, Z., 2006. Water pinch analysis for an urban system: a case study on the Sultan Ismail Mosque at the Universiti Teknologi Malaysia (UTM). *Desalination* 194, 52–68.
- Mavrotas, G., 2009. Effective implementation of the ϵ -constraint method in multi-objective mathematical programming problems. *Appl. Math. Comput.* 213, 455–465.
- Mirata, M., 2004. Experiences from early stages of a national industrial symbiosis programme in the UK: determinants and coordination challenges. *J. Clean Prod.* 12, 967–983.
- Oecd, 2008. Organisation for Economic Co-Operation and Development. OECD Environmental Outlook to 2030, Paris, France.
- Oh, D.S., Kim, K.B., Jeong, S.Y., 2005. Eco-industrial park design: a Daedeok Technovalley case study. *Habitat Int.* 29, 269–284.
- Olesen, S.G., Polley, G.T., 1996. Dealing with plant geography and piping constraints in water network design. *Process Saf. Environ. Prot.* 74, 273–276.
- PCSD (President's Council on Sustainable Development), 1996. Eco-Efficiency Task Force Report Washington, D.C, USA.
- Park, H.S., Rene, E.R., Choi, S.M., Chiu, A.S.F., 2008. Strategies for sustainable development of industrial park in Ulsan, South Korea - from spontaneous evolution to systematic expansion of industrial symbiosis. *J. Environ. Manage.* 87, 1–13.
- Poplewski, G., Walczyk, K., Jezowski, J., 2010. Optimization-based method for calculating water networks with user specified characteristics. *Chem. Eng. Res. Des.* 88, 109–120.
- Quesada, I., Grossmann, I.E., 1995. Global optimization of bilinear process networks with multicomponent flows. *Comp. Chem. Eng.* 19, 1219–1242.

- Roberts, B.H., 2004. The application of industrial ecology principles and planning guidelines for the development of eco-industrial parks: an Australian case study. *J. Clean Prod.* 12, 997–1010.
- Sahinidis, N.V., 2004. Optimization under uncertainty: state-of-the-art and opportunities. *Comp. Chem. Eng.* 28, 971–983.
- Sakr, D., Bass, L., El-Haggag, S., Huisin, R., 2011. Critical success and limiting factors for eco-industrial parks: global trends and Egyptian context. *J. Clean Prod.* 19, 1158–1165.
- Savelski, M., Bagajewicz, M., 2000. On the necessary conditions of water utilization systems in process plants with single contaminants. *Chem. Eng. Sci.* 55, 5035–5048.
- Shafei, S., Domenech, S., Koteles, R., Paris, J., 2004. System closure in pulp and paper mills: network analysis by genetic algorithm. *J. Clean Prod.* 12, 131–135.
- Shi, H., Chertow, M., Song, Y., 2010. Developing country experience with eco-industrial parks: a case study of the Tianjin Economical-Technological Development Area in China. *J. Clean Prod.* 18, 191–199.
- Sienutycz, S., Jezowski, J., 2009. Energy Optimization in Process Systems – Chapter 20: Approaches to Water Network Design. Elsevier, Oxford, UK, ISBN 0-08-045141-1. 613–657.
- Simmonds, P.L., 1862. Waste Products and Undeveloped Substances. Hardwicke, London.
- Tibbs, H.B.C., 1993. Industrial Ecology. An Environmental Agenda for Industry. Global Business Network, Emeryville, CA.
- Tiejun, D., 2010. Two quantitative indices for the planning and evaluation of eco-industrial parks. *Res. Conserv. Recycle* 54, 442–448.
- Tudor, T., Adam, E., Bates, M., 2007. Drivers and limitations for the successful development and functioning of EIPs (eco-industrial parks): a literature review. *Ecol. Econ.* 61, 199–207.
- UNESCO, Paris and Earthscan, London, 2009. World Water Assessment Programme. The United Nations World Water Development Report 3: Water in a Changing World.
- Van Beers, D., Corder, G., Bossilkov, A., Van Berkel, R., 2007. Industrial symbiosis in the Australian minerals industry: the cases of Kwinana and Gladstone. *J. Ind. Ecol.* 11, 55–72.
- Van Berkel, R., 2007. Cleaner production and eco-efficiency initiatives in Western Australia 1996–2004. *J. Clean Prod.* 15, 741–755.
- Van Leeuwen, M.G., Vermeulen, W.J.V., Glasbergen, P., 2003. Planning eco-industrial parks: an analysis of Dutch planning methods. *Bus. Strat. Environ.* 12, 147–162.
- Veiga, E., Bechara, L., Magrini, A., 2009. Eco-industrial park development in Rio de Janeiro, Brazil: a tool for sustainable development. *J. Clean Prod.* 17, 653–661.
- Wang, Y.P., Smith, R., 1994. Wastewater minimization. *Chem. Eng. Sci.* 49, 981–1006.
- Wan Alwi, S.R., Manan, Z.A., Samingin, M.H., Misran, N., 2008. A holistic framework for design of cost-effective minimum water utilization network. *J. Environ. Manage.* 88, 219–252.
- Watanabe, C., 1972. Industrial-Ecology: Introduction of Ecology into Industrial Policy. Ministry of International Trade and Industry (MITI), Tokyo.
- Zhu, L., Zhou, J., Cui, Z., Liu, L., 2010. A method for controlling enterprises access to an eco-industrial park. *Sci. Total Environ.* 408, 4817–4825.