

Patterns in fish assemblages in the Loire floodplain: The role of hydrological connectivity and implications for conservation

Emilien Lasne^{a,*}, Sovan Lek^b, Pascal Laffaille^a

^aUniversity of Rennes 1, ERT 52 – Bâtiment 25, 1er étage, Campus Beaulieu, 35 042 Rennes Cedex, France

^bUniversity of Toulouse 3, EDB, UMR 5174, CNRS – 118, route de Narbonne, 31 062 Toulouse Cedex, France

A B S T R A C T

Hydrological connectivity is known to determine biodiversity patterns across large river floodplains, but it is often greatly altered by human activities. Indicators and predictors of the response of river alteration or restoration are therefore needed. Recent papers suggested that fish environmental guilds – based on species flow preferences – could be used as a tool to assess ecological status of rivers. In the Loire floodplain, we described fish assemblages across the floodplain at the onset of the dry season and we determined whether observed spatial patterns could be related to environmental variables, especially connectivity. Based on specific composition of 46 electrofished waterbodies, a hierarchical typology of the Loire floodplain assemblages was built using self-organizing maps. Each assemblage of the typology was characterized by a set of species using the indicator value method. These species sets and the composition of the assemblages revealed a gradient of flow preferences in the different assemblages identified. A stepwise discriminant analysis showed that the most important variable determining assemblage composition was the hydrological connectivity. Finally, the conclusion was made that a high connectivity level is needed to conserve native fish diversity in the Loire floodplain, notably because the number of protected and native species increased with connectivity, and because the number of exotic species increased with isolation.

Keywords:

Ecological guilds
Native
Exotic
Indicator species
Large rivers
Management

1. Introduction

Large river floodplains host high levels of aquatic biodiversity (Petts and Amoros, 1996; Ward, 1998). Several studies (e.g. Tockner et al., 1999a; Ward et al., 1999) suggested that this general pattern results from hydrological connectivity, which is defined by Amoros and Bornette (2002) as “the permanent and episodic links between the main course of a river and the various waterbodies lying in the alluvial floodplain”. Hydrological connectivity depends on the flood pulse functioning of a river (Junk et al., 1989; Tockner et al., 2000). It determines numerous habitat features (e.g. flow intensity, substratum, vegetation cover; Tockner et al., 1999b; Amoros,

2001) and the accessibility of the different aquatic habitat patches (Granado-Lorenzo et al., 2005). Both are main components that determine species distribution. Natural floodplains are composed of various aquatic habitats ranging from lotic to semi-lotic and lentic habitats, more or less accessible in time. They provide an original habitat template (sensu Southwood, 1977; Poff and Ward, 1990) which constrains the ecological attributes of organisms that inhabit these systems. As a result, species that evolved in such contexts may be adapted to the natural flow regime (Lytle and Poff, 2004): which means natural hydrological patterns are necessary to achieve the whole life cycle. For instance, numerous fish species require different habitats for reproduction, growth or refuge;

* Corresponding author: Tel.: +33 (0) 223 236 936; fax: +33 (0) 223 235 138.

E-mail addresses: emilien.lasne@univ-rennes1.fr (E. Lasne), lek@cict.fr (S. Lek), pascal.laffaille@univ-rennes1.fr (P. Laffaille).

backwaters typically serve as nursery for young fish whereas adults live in the main channel or connected side arms (Copp, 1989a; Schiemer, 2000; Grift et al., 2001).

Floodplains are today amongst the most threatened ecosystems (Tockner and Stanford, 2002). Indeed, they are altered by numerous human activities such as flow regulation, damming, agricultural practices or extractions, which tend to decrease the flood pulse functioning and hydrological connectivity across the floodplain. As a consequence, habitat diversity patterns are strongly affected and largely homogenized (Bunn and Arthington, 2002). Such modifications may be dramatic for species adapted to the natural flow regime and especially to flow heterogeneity, and on the contrary, exotic species may benefit from habitat stabilisation and could invade altered habitats (Poff et al., 1997; Bunn and Arthington, 2002). The links and the opportunity of movements of organisms between aquatic patches is lowered (Bunn and Arthington, 2002). As a consequence, biodiversity associated to floodplain is largely threatened.

Facing this problem, tools to assess and predict the effect of habitat alteration or restoration on biota need to be developed (Jungwirth et al., 2002). In such a context, Aarts et al. (2004) and Welcomme et al. (2006) suggested that fish environmental guilds could be used as a tool for the assessment of ecological status of rivers. They proposed that the distribution patterns of species according to their flow preference could provide an indication or predict the response to river, especially alteration of hydrology and connectivity. However, these authors recognized that this scheme still needs to be tested on the field and statistically supported.

In the present study, we examined fish assemblages as indicators of hydrological connectivity across the Loire floodplain (France). More specifically, the patterns in fish assemblages were examined in order to evaluate (1) the role of species flow preferences on fish distribution across the floodplain and (2) the role of various levels of connectivity on fish assemblages patterns notably the distribution of native and exotic species.

2. Materials and methods

2.1. Study area

The Loire is the largest river of France. It is 1012 km long and drains a 117,000 km² catchment (Fig. 1). Its course rises from Massif Central to Atlantic Ocean. It is often said to be one of “the last wild large rivers of Europe” (<http://www.uicn.org>). This assertion is mainly due to the fact that its flow is unregulated in a large part of its course and it exhibits strong water level fluctuations. It is characterized by high flow levels during winter and low ones during summer. Moreover, unpredictable flash floods may occur during spring and fall. In the floodplain, the river bed is sandy and erosion–accretion processes lead to the wandering of the river. This natural process and the resulting successional dynamics have been altered by the construction of levees or riprap banks that aim at limiting reach erosion for human safety or agricultural practices.

The study area is located in the downstream part of Loire (from –8.5 km to 129 km from saline limit, Fig. 1). In this sector, the Loire floodplain presents a wide array of waterbodies from eutotamon (side arms) to paleototamon and temporary wetlands according to Amoros et al. (1987) typology. These different waterbodies result from the successional dynamics throughout the alluvial floodplain. In this area, the maximal flow levels are observed in winter and minimal discharges are observed in August–September (Fig. 2). During high flows, the floodplain may be overflowed, though some sectors are protected by levees. Wandering may also be limited by dikes and groynes. In addition, sand extractions from the river bed made in the last century have lowered the water level. However, some sectors remain poorly embanked and exhibit a large floodplain where the main channel can wander. As a consequence, lateral waterbodies resulting from main channel wandering are more or less connected (Fig. 3).

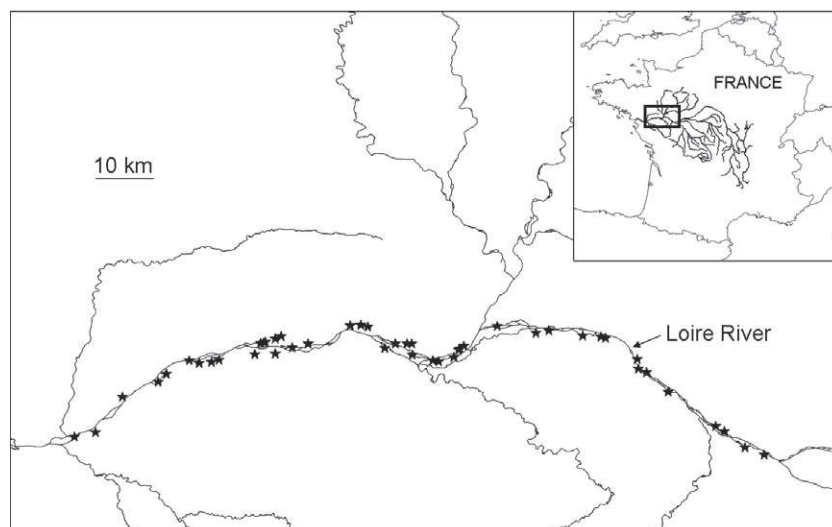

Fig. 1 – Study sector. Localisation of the study sector and the 46 sampled sites represented by black stars.

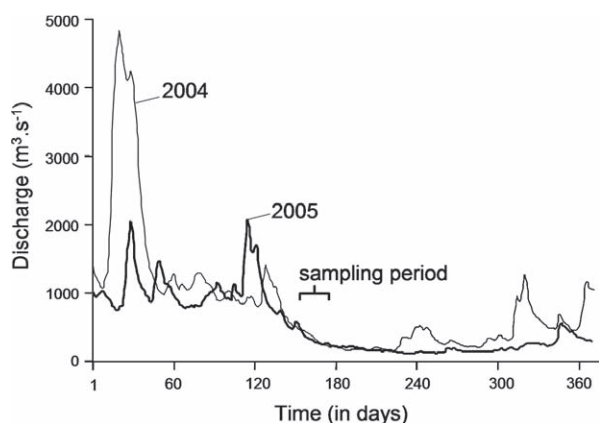

Fig. 2 – Hydrological flow and sampling period. Hydrological flow of the Loire River in years 2004–2005 measured in the study sector and sampling period.

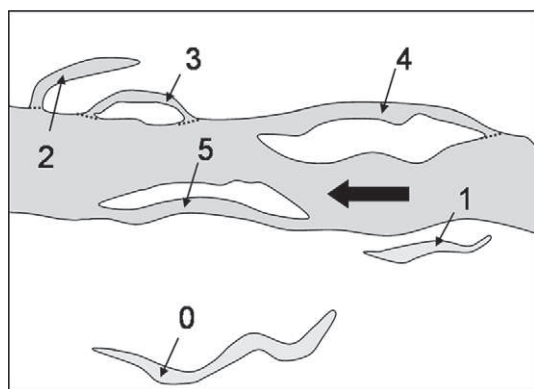

Fig. 3 – Typology of hydrological connectivity. Typology of hydrological connectivity of waterbodies based on the modalities of connection with the main channel. Hydrological connectivity decreases from class 5 to class 0: 5 = side arm connected at both ends at sampling period; 4 = side arm connected at downstream end at sampling period; 3 = side arm disconnected at sampling period; 2 = abandoned side-arm regularly connected at downstream end during winter flow; 1 = isolated waterbodies close to the main channel (<500 m) connected during medium winter floods; 0 = isolated waterbodies away from the main channel (>500 m) only connected during high floods. Dotted lines show disconnections of waterbodies during low water levels, the large black arrow shows the direction of the flow (after Amorós et al., 1987; modified).

2.2. Data collection

Fish were sampled in June 2004 and 2005 in 46 different sites. At this time, the flow is weak enough to allow a large habitat heterogeneity in the floodplain (according to the “telescoping model” of Ward and Tockner, 2001; Fig. 2). Indeed, before this period (i.e. during the flood pulse), most of the waterbodies are interconnected, and fish are relatively free to move across the floodplain. At the onset of the dry phase (i.e. in May–June),

habitat heterogeneity strongly increases, and fish have to settle in the various waterbodies according to individual species requirements for growth or reproduction. This is a key period in that fish theoretically chose the most suitable place to accomplish these functions. Thus, in June, fish distribution analysis should be very informative. Later in the dry period (August or September), some waterbodies may dry dramatically, even totally. Fish densities also be substantially altered by water surface reduction or by mortality induced by harsh summer conditions (e.g. anoxia). Consequently, fish distribution analysis may be largely biased.

We used a EFKO electroshocker (DC, 300–600 V, 6–8 A) with a 30 cm diameter anode set on a 2 m long pole. Such equipment permitted the catch of a large range of fish sizes, but did not catch larvae for which specific protocols are needed (Copp, 1989b). As a result, our data set was composed of larger and more easily identifiable individuals. However, when fish identity was doubtful, they were kept for later confirmation.

We used the Point Abundance Sampling (PAS) method according to Nelva et al. (1979). This rapid and cheap method provides reproducible and quantitative samples, and hence permits spatial comparisons between sampling sites. In a large river, Persat and Copp (1990) noted that a “stable” image of taxocenose structure can be obtained with only 25 random point samples in the various microhabitats. According to the size of each waterbodies and the heterogeneity of sites, 25–35 random PAS were performed per waterbodies.

Fish species were identified at each PAS and presence–absence data were used in order to calculate the occurrence frequency of species within each waterbody (OF = number of PAS where the species is sampled per total number of PAS in each waterbody) that could be used as an index of local occurrence.

Habitats were firstly described at the sampling point scale: depth (cm, ranged from 5 to 200), % of aquatic vegetation cover (ranged from 0 to 100), substratum composition (occurrence of silt, sand, gravel, pebbles and boulders) and topography (an index of the slope of the waterbed; the higher the value, the steeper the bank of the waterbody – ranged from 0, flat waterbed to 5, steep waterbed). According to Persat et al. (1985), mean values of microhabitat variables may be used to characterize the sites. Several other parameters were measured at the waterbody and floodplain scale: distance to main channel (m, ranged from 0 to 1810), conductivity ($\mu\text{S cm}^{-1}$, ranged from 235 to 720), temperature ($^{\circ}\text{C}$, ranged from 15 to 28), water transparency (m, ranged from 0 to 1.3) and distance to saline limit (km, ranged from –8.5 to 129). Waterbody connectivity was evaluated on the basis of previous studies (Amorós et al., 1987; see Fig. 3). Water was fresh (salinity close to zero) in all the sampled sites.

2.3. Data analysis

Our objective was to describe fish assemblages across the floodplain, and to determine whether observed patterns could be related to environmental variables. Thus, data analysis was performed following four steps. The first step consisted in the identification of fish assemblage types. In the second step, indicator species that could be used to characterize these assemblages were identified. In the third step, the analysis of assemblages composition was made on the basis

of various criteria (e.g. fish flow preference) in order to understand the way species were associated. Finally, the objective in the fourth step was to interpret the assemblages of species by testing if the environmental variables were different in each of the clusters of sites.

2.3.1. Fish assemblages assessment

A fish assemblage classification was performed using a self-organizing maps (SOM). This non-supervised artificial neural network method allows the analysis of complex data sets and the analysis of non-linear relationships (Kohonen, 2001). It has been recognized as a powerful tool for describing species distribution and assemblages (Lek et al., 2005). We followed the protocol of C er eghino et al. (2005), Ibarra et al. (2005) and Park et al. (2006) who studied fish patterns along the longitudinal gradient in the Garonne basin (see these papers for more details on the SOM method). Samples with similar species composition (based on species presence-absence data at the waterbody level) were classified in the same cell, or in the neighbour cells. However, by using weight vectors of trained SOM, the clustering techniques (Ward's method) allowed subdividing the SOM cells into several clusters, i.e. subgroups of community assemblages.

2.3.2. Identification of indicator species

In order to test if the clusters of sites could be characterized by indicator species on the basis of individual species occurrence frequency (OF) in each site, we used the indicator value (IndVal) according to the method developed by Dufr ene and Legendre (1997). The IndVal, expressed as a percentage, is based on both the fidelity and the specificity of species for each cluster of a typology. The IndVal of species i in cluster j is expressed as a % and was calculated using species occurrence frequency in each waterbody as follows: $IndVal_{ij} = A_{ij} \times B_{ij} \times 100$, where $A_{ij} (= \sum OF_{ij} / \sum OF_i)$ is a measure of the specificity of species i to the cluster j and $B_{ij} (= N_{sites_{ij}} / N_{sites_j})$ is a measure of the fidelity of species i to cluster j .

Only significant $IndVal > 25$ have been taken into account. Indeed, $IndVal > 25$ implies that the species is present in at least 50% of the sites of the cluster, and that this cluster contains at least 50% of the total data of the species (see Dufr ene and Legendre, 1997 for details on the method). The IndVal software can be downloaded at <http://mrw.wallonie.be/dgrne/sibw/outils/indval/home.html>.

2.3.3. Analysis of fish assemblages composition

The assemblage composition of each SOM cluster was analysed according to various criteria. Firstly, we distinguished different flow preference guilds (modified from Aarts et al., 2004): rheophilic, limnophilic or eurytopic. In each site, the number of species per guild was estimated. Secondly, the number of species that benefit from special conservation status was counted on the basis of the French legislation, the European Union Habitats Directive 92/43/EEC (annex II and V) and the Bern convention (annex III). Thirdly, the number of native and exotic species (according to Copp et al., 2005) was noted. Finally, species richness (number of species per waterbody) was estimated. The mean values of each of these criteria were compared across clusters by using Kruskal-Wallis and Dunn's post test.

2.3.4. Discrimination of fish assemblages by environmental variables

A backward stepwise discriminant analysis was used to determine whether clusters of sites derived from the SOM procedure and based on specific composition could be discriminated using a set of selected environmental variables. A random Monte-Carlo permutation test and a leave-one-out cross validation were used to assess the ability of these variables to predict the clusters.

The SOM were computed with SOM toolbox  (Alhoniemi et al., 2000, available at <http://www.cis.hut.fi/projects/som-toolbox/>) under Matlab environment (The Mathworks Inc., Natick, MA, USA) and other statistical analyses were operated with SYSTAT 8.0 (SPSS Inc., Chicago, IL, USA) and R (Ihaka and Gentleman, 1996).

3. Results

3.1. Fish assemblages

A total of 16,000 fishes corresponding to 30 species were sampled but the number of specimens highly varied according to species (Table 1). The most frequent fishes (that occurred in >75% of the sites) were all eurytopic: the pumpkinseed (*Lepomis gibbosus*), the European eel (*Anguilla anguilla*), the bream (*Abramis brama* + *Blicca bjoerkna*) and the roach (*Rutilus rutilus*). Other eurytopic species were frequent (50% < occurrence frequency < 75%) as perch (*Perca fluviatilis*), top mouth gudgeon (*Pseudorasbora parva*), bleak (*Alburnus alburnus*) and pike (*Esox lucius*). Except bitterling (*Rhodeus amarus*), black bullhead (*Ameiurus melas*) and chub (*Leuciscus cephalus*), limnophilic and rheophilic species were scarcer.

Among the 30 species, eight benefit from a particular conservation status and the majority were rheophilic (six), however, they were scarce. Only bitterling (limnophilic) and pike (eurytopic) were frequently observed. A total of nine non-native species were caught, and none of them were rheophilic. The most frequent were pumpkinseed (eurytopic), top mouth gudgeon (eurytopic) and black bullhead (limnophilic).

The SOM procedure clustered sites of similar specific composition (Fig. 4). The 46 sampled waterbodies were distributed quite homogeneously on the map which presented only 11 empty cells and a maximum of four sites in a cell. The hierarchical analysis between SOM cells permitted an identification at the higher hierarchy level two large clusters I and II which contained 17 and 29 sites, respectively (Fig. 4). Each of these large clusters subdivided into two smaller sub-clusters at the lower hierarchy level. The cluster I subdivided into Ia and Ib sub-clusters which contained 10 and 7 sites, respectively, and large cluster II subdivided into IIa and IIb sub-clusters which contained 16 and 13 sites, respectively.

3.2. Indicator species

Apart from cluster Ia, the IndVal method identified indicator species for the different clusters at each hierarchy level (Fig. 5). Clusters of the branch I of the dendrogram were characterized by a small number of indicator species (four), while 12 species characterized the branch II. In branch I, cluster I was characterized by a single eurytopic species (the Giebel

Table 1 – List of species

Common name	Scientific name	Flow preference	Origin	Conservation status	N	Occurrence frequency
Pumpkinseed	<i>Lepomis gibbosus</i> (L., 1758)	Eurytopic	E		1574	0.89
European Eel	<i>Anguilla anguilla</i> (L., 1758)	Eurytopic	N		1090	0.85
Breams	<i>Abramis brama</i> + <i>Blicca bjoerkna</i> (L., 1766)	Eurytopic	N		687	0.83
Roach	<i>Rutilus rutilus</i> (L., 1758)	Eurytopic	N		2328	0.83
Bitterling	<i>Rhodeus amarus</i> (Bloch, 1782)	Limnophilic	N	H-II, B-III, FL	3502	0.72
Perch	<i>Perca fluviatilis</i> (L., 1758)	Eurytopic	N		605	0.65
Top mouth gudgeon	<i>Pseudorasbora parva</i> (Schlegel, 1842)	Eurytopic	E		969	0.63
Bleak	<i>Alburnus alburnus</i> (L., 1758)	Eurytopic	N		652	0.61
Pike	<i>Esox lucius</i> (L., 1758)	Eurytopic	N	FL	192	0.59
Black bullhead	<i>Ameiurus melas</i> (Rafinesque, 1820)	Limnophilic	E		1222	0.57
Chub	<i>Leuciscus cephalus</i> (L., 1766)	Rheophilic	N		370	0.54
Gudgeon	<i>Gobio gobio</i> (L., 1766)	Rheophilic	N		775	0.43
Rudd	<i>Scardinius erythrophthalmus</i> (L., 1758)	Limnophilic	N		53	0.41
Tench	<i>Tinca tinca</i> (L., 1758)	Limnophilic	N		44	0.35
Pikeperch	<i>Sander lucioperca</i> (L., 1758)	Eurytopic	E		132	0.33
Gibel carp	<i>Carassius auratus gibelio</i> (Bloch, 1782)	Eurytopic	E		71	0.20
Carp	<i>Cyprinus carpio</i> (L., 1758)	Eurytopic	E		1753	0.15
Ruffe	<i>Gymnocephalus cernuus</i> (L., 1758)	Eurytopic	N		41	0.15
Barbel	<i>Barbus barbus</i> (L., 1758)	Rheophilic	N	H-V	40	0.13
Wels	<i>Silurus glanis</i> (L., 1758)	Eurytopic	E		19	0.13
Dace	<i>Leuciscus leuciscus</i> (L., 1758)	Rheophilic	N	FL	27	0.11
Black bass	<i>Micropterus salmoides</i> (Lacépède, 1802)	Limnophilic	E		4	0.07
Sea lamprey	<i>Petromyzon marinus</i> (L., 1758)	Rheophilic	N	H-II, B-III	28	0.07
Mosquitofish	<i>Gambusia affinis</i> (Girard, 1859)	Eurytopic	E		5	0.04
Three-spined stickleback	<i>Gasterosteus aculeatus</i> (L. 1966)	Eurytopic	N		4	0.04
Flounder	<i>Platichthys flesus</i> (L., 1758)	Rheophilic	N		5	0.04
Stream bleak	<i>Alburnoides bipunctatus</i> (Bloch, 1782)	Rheophilic	N	B-III	25	0.02
Nase	<i>Chondrostoma nasus</i> (L., 1766)	Rheophilic	N	B-III	15	0.02
Spined loach	<i>Cobitis taenia</i> (L., 1758)	Rheophilic	N	H-II, B-III	1	0.02
Thin-lipped grey mullet	<i>Liza ramada</i> (Risso, 1826)	Rheophilic	N		1	0.02

List of species, flow preferences (modified after Aarts et al., 2004), origine (N: native, E: exotic, according to Keith and Allardi, 2001 and Copp et al., 2005), conservation status (FL = French legislation; HII and HV = annex II and V of the Habitats Directive, BIII = annex III of the Bern convention) number of individuals and occurrence frequency (% of sites occupied; N = 46) of species caught in the 46 waterbodies of Loire floodplain in June 2004 and 2005. Species are listed in alphabetic order for each flow preferences guild.

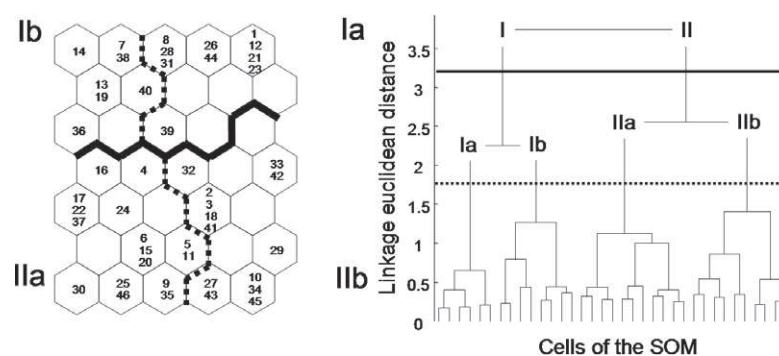

Fig. 4 – Results of the SOM model. Classification of sites on SOM using species fish composition data. Dendrogram of the SOM output matrix shows groups of the similarity of cells on SOM, and then identifying the community assemblages of fish. Two levels cut-off allowed the identification of two big clusters (bold lines) that each subdivided into two smaller ones (dotted lines) Ia (10 sites) and Ib (7 sites), and IIa (16 sites) and IIb (13 sites).

carp *Carassius auratus gibelio*), cluster Ib was characterized by one eurytopic (the pikeperch *Sander lucioperca*) and two limnophilic species (the rudd *Scardinius erythrophthalmus* and the black bullhead). In branch II, three eurytopic (the pike, the perch and the ruffe *Gymnocephalus cernuus*) and it one limno-

philic (the tench *Tinca tinca*) species were indicators of cluster IIa whereas cluster IIb was only characterized by rheophilic species (the chub, the dace *Leuciscus leuciscus* and the barbel *Barbus barbus*). Cluster II, that encompassed these two contrasted clusters, was characterized by a mix of rheophilic

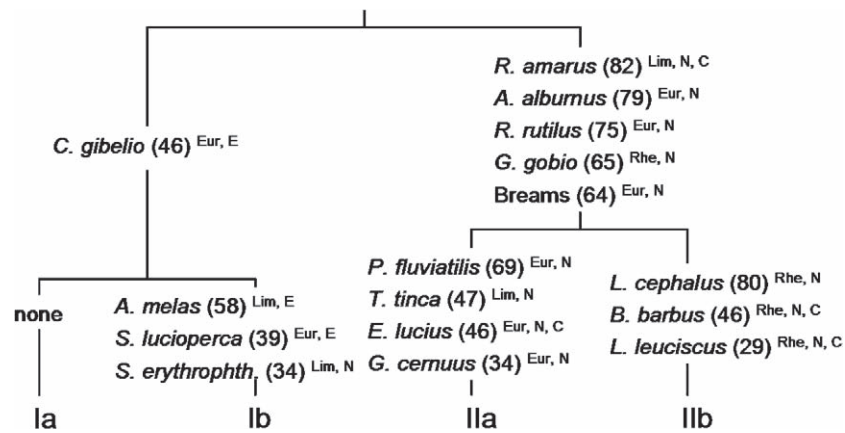

Fig. 5 – Indicator species. Indicator species for each cluster of the dendrogram produced by the SOM model. Maximal IndVal (%) for indicator species are indicated in parenthesis. Only significant ($p < 0.05$) > 25% IndVal are presented. Exponent labels provide indications on species flow preferences (Eur = eurytopic, Lim = limnophilic, Rhe = rheophilic), origine (N = native, E = exotic) and conservation status (C means that the species benefit from a special conservation status; see text for details).

(the gudgeon), limnophilic (the bitterling) and eurytopic (the bleak, the roach and the bream) species. No indicator species had a conservation status in the cluster of branch I (Fig. 5), while four did in the clusters of branch II (the bitterling, the pike, the barbel and the dace). In clusters I and Ib, three indicator species were exotic, whereas only one, the rudd, was native (Fig. 5). In contrast, only native species characterized the clusters II, IIa and IIb.

3.3. Fish assemblages composition

When considering the specific composition of the four clusters of the lower hierarchy level, we first noted that the number of species tended to be higher in clusters IIa and IIb (which hosted on average 12.9 and 11.5 species, respectively) than in cluster Ib (9.9 species) and cluster Ia where it was relatively low (5.6 species) (Fig. 6a). In cluster Ia, the number of species was much more variable than in other clusters, as well as the number of eurytopic species (Fig. 6b). Contrary to other flow preferences guilds, eurytopic were relatively equally represented in clusters Ib, IIa and IIb. Indeed, the number of limnophilic species tended to be higher in clusters IIb and Ia than in cluster IIa (and also than in cluster Ia; Fig. 6c). No rheophilic species were found in cluster Ib and a maximum of one species was found in cluster Ia (Fig. 6d). Cluster IIa, and above all cluster IIb, hosted a higher number of rheophilic species. The number of native species was much lower in clusters Ia and Ib than in clusters IIa and IIb (Fig. 6e). The number of exotic species followed the opposite pattern (Fig. 6f). Finally, the number of protected species was higher in clusters IIa and IIb due to the most protected species being rheophilic (Fig. 6g).

3.4. Environmental gradient analysis

Among all the input environmental variables, the backward stepwise discriminant analysis selected a set of six variables – connectivity, vegetation cover, topography, silt and pebble and distance to saline limit – to predict the four sub-clusters

of assemblages Ia, Ib, IIa and IIb. These variables had contrasted mean values in each of the clusters (Table 2). Three discriminant functions have been generated, and the random Monte-Carlo permutation test showed that they were highly significant ($p < 0.001$). Each of these functions – F1, F2 and F3 – accounted for 72%, 25% and 3% of the between-clusters variability, respectively. F1 (horizontal axis, Fig. 7) was firstly determined by connectivity (cosines = -0.84) and to a lesser extent by vegetation cover (0.52), silt (0.43) and pebbles occurrence (0.41). Function 2 (vertical axis, Fig. 7) was mainly determined by the vegetation cover (0.64), the topography (-0.60), pebbles occurrence (-0.58), and to a lesser extent by the distance to saline limit (-0.35). Function 3 accounted for only 3% of between-clusters variability and was not taken into account any further. The leave-one-out cross validation procedure permitted sites to be reassigned into suitable clusters (and associated fish assemblages) with an average success of 70% (60% for cluster Ia, 67% for cluster Ib, 63% for cluster IIa, and 91% for cluster IIb).

Connectivity was the main factor that influenced fish species distribution. Indeed, F1 allowed the separation of the cluster IIb (corresponding to connected waterbodies), cluster IIa (corresponding to sites of intermediate connectivity), and Ia and Ib (corresponding to isolated waterbodies). F2 allowed the separation of clusters Ia and Ib. Cluster Ia may be distinguished from cluster Ib by higher vegetation cover, occurrence of silt and lower topographic values. These two variables are also related to hydrological connectivity. Indeed, cluster Ia was composed of flat-bottomed isolated waterbodies which disconnect very early in the season and a field visit in late summer revealed that they had a higher probability of drought than sites of cluster Ib. High vegetation levels and abundance of silt also suggested that they are rarely and/or weakly scoured by flow. On the contrary, sites of cluster Ib seemed to offer more stable conditions in summer and a higher permanency related to site topography. The higher abundance of pebbles also suggested a stronger scouring effect of flow during high levels. Finally, it was possible to classify the four clusters along a “true hydrological connectivity”

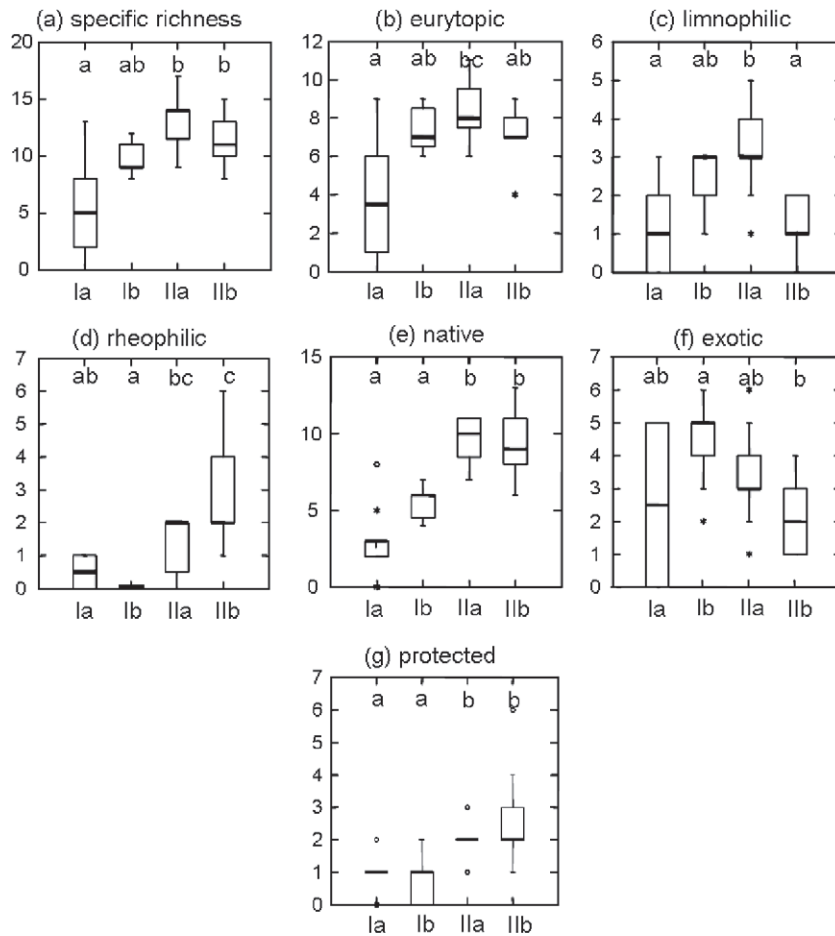

Fig. 6 – Description of the assemblages. Box plots of specific richness (a), abundance of eurytopic (b), limnophilic (c), rheophilic (d), native (e), exotic (f), protected (g) species in each cluster of the lower hierarchy level. The absence of common letter over of the box plots shows pairwise significant differences between clusters (Kruskal–Wallis test and Dunn’s post test; $p < 0.05$). Bold line within each box plot indicates the median. The abscissas represent the cluster number, while the ordinates represent the number of species.

Table 2 – Discriminating environmental variables

Variables	Clusters			
	Ia	Ib	IIa	IIb
Distance to saline limit (km)	37.5 (± 34.8)	62.7 (± 47.8)	58.2 (± 33.1)	62.6 (± 36.1)
Connectivity (0–5)	1.1 (± 1.4)	0.6 (± 0.8)	1.9 (± 1.2)	3.9 (± 1.2)
Vegetation cover (%)	41.5 (± 10.0)	24.5 (± 17.1)	20.9 (± 24.0)	4.8 (± 8.0)
Silt (%)	61.1 (± 31.3)	44.7 (± 34.6)	52.9 (± 29.4)	19.8 (± 17.8)
Pebbles (%)	2.0 (± 3.3)	0.6 (± 23.5)	1.5 (± 2.5)	3.8 (± 10.5)
Topography (0–5)	1.4 (± 0.7)	2.9 (± 1.1)	1.9 (± 1)	2.0 (± 0.9)

Mean values (\pm SD) of the six discriminating environmental variables in each of the clusters of the lower hierarchy level.

gradient: with connectivity increasing along the gradient Ia–Ib–IIa–IIb.

4. Discussion

4.1. The Loire floodplain hosts high species richness

Following Huet’s zonation in western European rivers (1959), the section of river studied is located in the bream zone. How-

ever, we also found some species that are typical of the barbel zone such as the barbel, the chub and the dace. A total of 30 species have been sampled in this study. This is equal to about 75% of the total fish richness that has been described in both this study and the long term survey of the National French Fishing Council (NFFC, pers. comm.). In NFFC survey, all the four zones of Huet’s zonation (1959) were sampled throughout the Loire catchment. In France, Ibarra et al. (2005) mentioned 40 fish species in the Garonne basin and

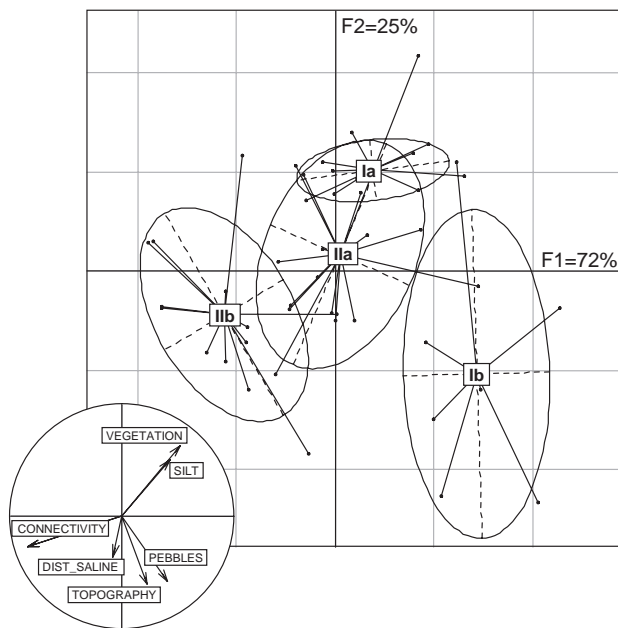

Fig. 7 – Results of the backward stepwise discriminant analysis. Results of the backward stepwise discriminant analysis using 6 environmental variables to predict the 4 clusters of sites (identified from SOM model). Axis 1 and 2 shows 72% and 25% of between-group variability, respectively. Each cluster of sites of the lower hierarchy level is presented as ellipsoid with the cluster name in the center. The variable distance to saline limit is abbreviated DIST_SALINE.

Oberdorff et al. (1993), 30 fish species in the Seine basin. The high species richness we observed may be explained by the very high heterogeneity of aquatic habitats. Indeed, in this 130 km long section, we sampled both oxbow lakes and lentic habitats of the typical of the bream sector, but also sandy channels that were similar to those observed in the braided section of the barbel zone. Such heterogeneity would enable the co-occurrence of species of various life-history strategies. Thus, the Loire floodplain hosts relatively high fish species richness and could therefore be very valuable for fish conservation.

4.2. Patterns in fish assemblages and their relation to hydrological connectivity

Assemblage composition and indicator species in the Loire floodplain showed that fish patterns in the early dry period were mainly determined by species flow preferences. The analysis of environmental variables also revealed the major role of hydrological connectivity, which in turn would determine local habitat features such as vegetation cover or substratum (Tockner et al., 1999b; Amoros and Bornette, 2002). The various assemblages could be characterized by sets of indicator species with contrasted flow preferences. However, cluster Ia (i.e. on the extremity of the connectivity gradient) showed a high variability in species composition (see Fig. 6) which may result from stochastic events probably related to variable extinction and colonisation rates.

As suggested by Aarts et al. (2004), the lateral organisation of fish assemblages in floodplains was quite similar to the lotic-to-lentic longitudinal zonation described by Huet (1959). Moreover, our study – which implies a greater number of waterbodies and a specific sampling design – provides quantitative and statistical insights. Rheophilic species typical of the barbel zone were found next to the main channel in lotic waters, whereas species typical of the bream zone were found in relatively disconnected and isolated (semi-lotic to lentic waters). Moreover, the identification of two super-assemblages (I and II) showed a transition of species rather than a strict zonation. Indeed, Dufrêne and Legendre (1997) suggested that species of higher levels of the hierarchy tolerate a larger range of environmental conditions compared to species of lower levels which are considered as “stenotopic species”. This supports the hypothesis of Welcomme et al. (2006) that flow preferences of species are more or less flexible and could be described or analysed through a hierarchical approach. Moreover, the gradual species replacement pattern spread along the energy gradient (decreasing from main channel to isolated waterbodies) is somewhat similar to the patterns described in the River Continuum Concept proposed by Vannote et al. (1980).

4.3. Biocomplexity in floodplain waterbodies and indicator power of fish

Hydrological connectivity is often used to explain biodiversity patterns in floodplains. However, the measures that are used to quantify connectivity are highly variable (see for instance Aarts et al., 2004; Granado-Lorencio et al., 2005; Reckendorfer et al., 2006; Welcomme et al., 2006). A single metric is not sufficient to assess for floodplain hydrological connectivity and associated biocomplexity (Amoros and Bornette, 2002). For instance, the “a priori” index of connectivity used in this study (Fig. 3) is somewhat imperfect because it did not account for all of the aspects of connectivity, especially temporal aspects (i.e. connection frequency or waterbody permanency). Such information may be very difficult to obtain. Moreover, the various components of connectivity may have different meanings for aquatic biota. Some of these components determine habitat patch accessibility (e.g. distance to main channel), and others determine habitat patch suitability (e.g. flow velocity) both crucial determinants of species distribution (especially for fish, Jackson et al., 2001). Future studies that deal with connectivity should pay particular attention to the biocomplexity associated with connectivity (Amoros and Bornette, 2002) and its various implications for biota.

Thus, since hydrological connectivity results in complex and sometimes antagonistic processes, synthetic indicators of ecological integrity and functioning patterns of river floodplains are needed. In this framework, clustering Loire floodplain waterbodies using fish specific composition provided significant information. It revealed that fish patterns were largely related to hydrological connectivity. More precisely, it showed that the typology of connectivity we used was fairly relevant for fish. Indeed, the latter provided the stronger contribution for assemblage discrimination. However, other variables were also important. For instance, assemblage clusters Ia and Ib were quite similar on the basis of the connectivity

index, but differed in term of substrate and waterbed morphology. Thus, according to Welcomme et al. (2006), our data showed that fish are good “integrators” of the various components of hydrological connectivity. In addition, because fish species have various levels of sensitivity to environmental variables, their individual and collective responses reveal a continuum of ecological conditions. Furthermore, the use of floodplain heterogeneity may be life-stage specific (Copp, 1989a; Schiemer, 2000; Grift et al., 2001). Size or age data could then be used to describe species distributions among the sites; for instance, age (or size) classes might be used as “pseudo-species” in the assemblages model to provide additional insights into which life stages are supported. This approach has not been developed in this study suggesting that the indicator potential of fish may still be improved. Finally, this study confirms that fish may be used to assess for environmental changes in the floodplain. More precisely, the method we developed could be applied to a network of reference sites regularly sampled. This would be then used to assess alteration or improvement of floodplain integrity. For instance the modifications of individual sites composition could be quantified as well as the modifications of assemblages patterns along the lateral gradient.

4.4. Ecological and conservation implications of hydrological connectivity

The alteration of natural flow regime is supposed to affect the distribution of native riverine biota (not only fish) and to favour the settlement and development of exotic species in various situations (Poff et al., 1997; Bunn and Arthington, 2002; Lytle and Poff, 2004). In the Loire floodplain, the distribution patterns of native and non-native species were highly contrasted along the lateral gradient. The number of native species decreased in disconnected waterbodies, whereas the number of exotic species decreased in connected areas. Moreover, the higher proportion of species that benefit from a special conservation status (and that are officially considered as more or less endangered) was located next to the main channel in connected waterbodies. In addition, the higher number of indicator species in connected and relatively well connected waterbodies (cluster II) showed that these waterbodies are very important for fish conservation. These results agree with Galat and Zweimüller (2001) who reported that, in most temperate large rivers, rheophilic species alias “fluvial fish” were more prone to extinction due to habitat alteration than “macrohabitat generalists”. These authors also report that exotic species are “macrohabitat generalist” that benefit from the loss of spatio-temporal heterogeneity. It was also the case in our study since most species of conservation concern were rheophilic, whereas most exotic species were eurytopic.

In the Loire floodplain, the strong hydrological gradient in the lateral dimension clarified the effects of various connectivity levels on fish assemblages during the early dry period (corresponding to reproductive period for most species). It is likely that further alteration of hydrological connectivity could have dramatic consequences for the fish fauna. Thus, it appears crucial to conserve or restore the flood pulse that permits the maintenance of high and intermediate connectiv-

ity levels and ultimately contributes to fish diversity in the Loire. The high spatio-temporal heterogeneity related to hydrological connectivity allows the coexistence of species with various life-history traits. Diversity patterns described for fish are not necessarily similar in other taxa (Tockner et al., 1998, 1999a). Most of the studies that deal with biodiversity patterns across the transversal gradient of the floodplain emphasize the role of natural and variable connectivity on diversity in taxa such as amoeba (Bini et al., 2003), molluscs (Reckendorfer et al., 2006), invertebrates (Sheldon et al., 2002), odonata (Chovanec et al., 2004) and amphibians (Tockner et al., 2006). Our study reinforces this with fish. Finally, global biodiversity is in general highest at intermediate levels of connectivity (Ward and Tockner, 2001).

Acknowledgements

This study was funded by DIREN Pays-de-la-Loire, Conseil Régional Pays-de-la-Loire and Agence de l’eau Loire-Bretagne. Technical support was provided by the Tableau de Bord Anguille du bassin de la Loire, des Côtiers Vendéens et de la Sèvre Niortaise (Aurore Baisez), Fish-Pass, FDAAPP-MA 44 and 49, and the National French Fishing Council (CSP). Authors are grateful to all the persons who permitted the access to sampling sites. Special thanks to Pauline Boury, Bruno Sacier, Julien Cucherousset, Soline Michaud, Patrick Martin, Laurent Limousin, Martin Lajournade, Johan Bonot and Matthieu Leray for field contribution and to Fabrice Hibert and Fabien Leprieur for statistical and conceptual help. Finally, thanks to Joseph Ebersole and three anonymous reviewers for helpful comments on manuscript, and to Robert Straughan and Béatrice Mounaix for last spelling corrections.

REFERENCES

- Aarts, B.G.W., Van den Brink, F.W.B., Nienhuis, P.H., 2004. Habitat loss as the main cause of the slow recovery of fish faunas of regulated large rivers in Europe: the transversal floodplain gradient. *River Research and Applications* 20, 3–23.
- Alhoniemi, E., Himberg, J., Parhankangas, J., Vesanto, J., 2000. SOM toolbox. Laboratory of Computer and Information Science, Helsinki University of Technology, Helsinki.
- Amoros, C., 2001. The concept of habitat diversity between and within ecosystems applied to a river side-arm restoration. *Environmental Management* 28, 805–817.
- Amoros, C., Bornette, G., 2002. Connectivity and biocomplexity in waterbodies of riverine floodplains. *Freshwater Biology* 47, 761–776.
- Amoros, C., Roux, A.L., Reygobellet, J.L., Bravard, J.-P., Pautou, G., 1987. A method for applied ecological studies of fluvial hydrosystems. *Regulated Rivers: Research and Management* 1, 17–36.
- Bini, L.M., Vehlo, L.F.M., Lansac-Tôha, F.A., 2003. The effect of connectivity on the relationship between local and regional species richness of testate amoebae (protozoa, rhizopoda) in floodplain lagoons of the Upper Paraná River, Brazil. *Acta Oecologica* 24, 145–151.
- Bunn, S.E., Arthington, A.H., 2002. Basic principles and ecological consequences of altered flow regimes for aquatic biodiversity. *Environmental Management* 4, 492–507.

- Céréghino, R., Santoul, F., Compin, A., Mastrorillo, S., 2005. Using self-organizing maps to investigate spatial patterns of non-native species. *Biological Conservation* 125, 459–465.
- Chovanec, A., Waringer, J., Raab, R., Laister, G., 2004. Lateral connectivity of a fragmented large river system: assessment on a macroscale by dragonfly surveys (Insecta: Odonata). *Aquatic Conservation: Marine and Freshwater Ecosystems* 14, 163–178.
- Copp, G.H., 1989a. The habitat diversity and fish reproductive function of floodplain ecosystems. *Environmental Biology of Fishes* 26, 1–27.
- Copp, G., 1989b. Electrofishing for fish larvae and 0+ juveniles: equipment modifications for increased efficiency with short fishes. *Aquaculture and Fisheries Management* 20, 453–462.
- Copp, G.H., Bianco, P.G., Bogutskaya, N.G., Eros, T., Falka, I., Ferreira, M.T., Fox, M.G., Freyhof, J., Gozlan, R.E., Grabowska, J., Kovac, V., Moreno-Amich, R., Naseka, A.M., Penaz, M., Povz, M., Przybylski, M., Robillard, M., Russel, I.C., Stakenas, S., Sumer, S., Vila-Gispert, A., Wiesner, C., 2005. To be, or not to be, a non-native freshwater fish. *Journal of Applied Ichthyology* 21, 242–262.
- Dufrène, M., Legendre, P., 1997. Species assemblages and indicator species: the need for a more flexible asymmetrical approach. *Ecological Monograph* 67, 345–366.
- Galat, D.L., Zweimüller, I., 2001. Conserving large-river fishes: is the highway analogy an appropriate paradigm? *Journal of the North American Benthological Society* 20, 266–279.
- Granado-Lorencio, C., Araujo Lima, C.R.M., Lobon-Cervia, J., 2005. Abundance–distribution relationships in fish assembly of the Amazonas floodplain lakes. *Ecography* 28, 515–520.
- Grift, R.E., Buijse, A.D., Klein Breteler, J.G.P., Van Densen, W.L.T., Machiels, M.A.M., Backx, J.J.G., 2001. Migration of bream between the main channel and floodplain lakes along the lower River Rhine during the connection phase. *Journal of Fish Biology* 59, 1033–1055.
- Huet, M., 1959. Profiles and biology of western European streams as related to fisheries management. *Transaction of the American Fisheries Society* 116, 155–163.
- Ibarra, A., Park, Y.-S., Brosse, S., Reyol, Y., Lim, P., Lek, S., 2005. Nested patterns of spatial diversity revealed for fish assemblages in a west European river. *Ecology of Freshwater Fish* 14, 233–242.
- Ihaka, R., Gentleman, R., 1996. R: a language for data analysis and graphics. *Journal of Computational and Graphical Statistics* 5, 299–314.
- Jackson, D.A., Peres-Neto, P.R., Olden, J.D., 2001. What controls who is where in freshwater fish communities – the roles of biotic, abiotic and spatial factors. *Canadian Journal of Fisheries and Aquatic Sciences* 58, 157–170.
- Jungwirth, M., Muhar, S., Schmutz, S., 2002. Re-establishing and assessing ecological integrity in riverine landscapes. *Freshwater Biology* 47, 867–887.
- Junk, W.J., Bayley, P.B., Sparks, R.E., 1989. The flood pulse concept in river-floodplain systems. *Canadian Special Publications in Fisheries and Aquatic Sciences* 106, 110–127.
- Keith, P., Allardi, J. (Eds.), 2001. Atlas des poissons d'eau douce de France. Publications Scientifiques du M.N.H.N., Paris.
- Kohonen, T. (Ed.), 2001. Self-organizing Maps. Springer-Verlag, Heidelberg.
- Lek, S., Scardi, M., Verdonshot, P., Descy, J.P., Park, Y.-S. (Eds.), 2005. Modelling Community Structure in Freshwater Ecosystems. Springer-Verlag, Heidelberg.
- Lytle, D.A., Poff, N.L., 2004. Adaptation to natural flow regimes. *Trends in Ecology and Evolution* 19, 94–100.
- Nelva, A., Persat, H., Chessel, D., 1979. Une nouvelle méthode d'étude des peuplements ichthyologiques dans les grands cours d'eau par échantillonnage ponctuel d'abondance. *Comptes Rendus de l'Académie des Sciences de Paris, Série D* 289, 679–791.
- Oberdorff, T., Guilbert, E., Lucchetta, J.-C., 1993. Patterns of fish species richness in the Seine river basin, France. *Hydrobiologia* 259, 157–167.
- Park, Y.-S., Grenouillet, G., Esperance, B., Lek, S., 2006. Stream fish assemblages and basin land cover in a river network. *Science of the Total Environment* 365, 140–153.
- Persat, H., Copp, G., 1990. Electric fishing and point abundance sampling for the ichthyology of large rivers. In: Cowx, I.G. (Ed.), *Developments in Electric Fishing*. Blackwell Scientific Publications, Oxford, pp. 203–215.
- Persat, H., Nelva, A., Chessel, D., 1985. Approche par l'analyse discriminante sur variables qualitatives d'un milieu lotique, le Haut Rhône français. *Acta Oecologica – Oecologia Generalis* 6 (4), 365–381.
- Petts, G.E., Amoros, C. (Eds.), 1996. *Fluvial Hydrosystems*. Chapman and Hall, London.
- Poff, N.L., Ward, J.V., 1990. Physical habitat template of lotic systems: recovery in the context of historical pattern of spatiotemporal heterogeneity. *Environmental Management* 14, 629–645.
- Poff, N.L., Allan, J.D., Bain, M.B., Karr, J.R., Prestegard, K.L., Richter, B.D., Sparks, R.E., Stromberg, J.C., 1997. The natural flow regime: a paradigm for river conservation and restoration. *Bioscience* 47, 769–784.
- Reckendorfer, W., Baranyi, C., Funk, A., Schiemer, F., 2006. Floodplain restoration by reinforcing hydrological connectivity: expected effects on aquatic mollusc communities. *Journal of Applied Ecology* 43, 474–484.
- Schiemer, F., 2000. Fish as indicators for the assessment of the ecological integrity of large rivers. *Hydrobiologia* 422–423, 271–278.
- Sheldon, F., Boulton, A.J., Puckridge, T.T., 2002. Conservation value of variable connectivity: aquatic invertebrate assemblages of channel and floodplain habitats of a central Australian arid-zone river, Cooper Creek. *Biological Conservation* 103, 13–31.
- Southwood, T.R.E., 1977. Habitat, the templet for ecological strategies? *Journal of Animal Ecology* 46, 337–365.
- Tockner, K., Stanford, J.A., 2002. Riverine flood plains: present state and future trends. *Environmental Conservation* 29, 308–330.
- Tockner, K., Schiemer, F., Ward, J.V., 1998. Conservation by restoration: the management concept for a river-floodplain system on the Danube River in Austria. *Aquatic Conservation: Marine and Freshwater Ecosystems* 8, 71–86.
- Tockner, K., Schiemer, F., Baumgartner, C., Kum, G., Weigand, E., Zweimüller, I., Ward, J.V., 1999a. The Danube restoration project: species diversity patterns across connectivity gradients in the floodplain system. *Regulated Rivers: Research and Management* 15, 245–258.
- Tockner, K., Pennetzdorfer, D., Reiner, N., Schiemer, F., Ward, J.V., 1999b. Hydrological connectivity, and the exchange of organic matter and nutrients in a dynamic river-floodplain system (Danube, Austria). *Freshwater Biology* 41, 521–535.
- Tockner, K., Malard, F., Ward, J.V., 2000. An extension of the flood pulse concept. *Hydrological Processes* 14, 2861–2883.
- Tockner, K., Klaus, I., Baumgartner, C., Ward, J.V., 2006. Amphibian diversity and nestedness in a dynamic floodplain river (Tagliamento, NE-Italy). *Hydrobiologia* 565, 121–133.

- Vannote, R.L., Minshall, G.W., Cummins, K.W., Sedell, J.R., Cushing, C.E., 1980. The river continuum concept. *Canadian Journal of Fisheries and Aquatic Sciences* 37, 130-137.
- Ward, J.V., 1998. Riverine landscapes: biodiversity patterns, disturbance regimes, and aquatic conservation. *Biological Conservation* 83 (3), 269-278.
- Ward, J.V., Tockner, K., 2001. Biodiversity: towards a unifying theme for river ecology. *Freshwater Biology* 46, 807-819.
- Ward, J.V., Tockner, K., Schiemer, F., 1999. Biodiversity of floodplain river ecosystems: ecotones and connectivity. *Regulated Rivers: Research and Management* 15, 125-139.
- Welcomme, R.L., Winemiller, K.O., Cowx, I.G., 2006. Fish environmental guilds as a tool for assessment of ecological condition of rivers. *River Research and Applications* 22, 377-396.