



Open Archive Toulouse Archive Ouverte (OATAO)

OATAO is an open access repository that collects the work of Toulouse researchers and makes it freely available over the web where possible.

This is an author-deposited version published in: <http://oatao.univ-toulouse.fr/>
Eprints ID : 2519

To link to this article :

URL : <http://dx.doi.org/10.1016/j.wear.2005.11.008>

To cite this version : Adamou , A.S. and Denape, J. and Paris, J.-Y and Andrieu, Eric (2006) [*An environmental tribometer for the study of rubbing surface reactivity.*](#) Wear, vol. 261 (n° 3 - 4). pp. 311-317. ISSN 0043-1648

Any correspondence concerning this service should be sent to the repository administrator: staff-oatao@inp-toulouse.fr

An environmental tribometer for the study of rubbing surface reactivity

A.S. Adamou^a, J. Denape^{a,*}, J.-Y. Paris^a, E. Andrieu^b

^a LGP-ENIT, Ecole Nationale d'Ingénieurs, B.P. 1629, 65016 TARBES Cedex, France

^b CIRIMAT ENSCIACET, 118 Route de Narbonne, 31077 TOULOUSE Cedex 4, France

Abstract

A new tribometer was designed to study the reactivity of rubbing surfaces under controlled environmental conditions. The contacting samples are isolated from the atmosphere by a chamber under secondary vacuum (10^{-6} mbar) where reactive gasses can be injected. The sample chamber can also be heated up to 900 °C by a radiative furnace. The sliding velocity can be varied from 0.05 to 1.5 m/s and the applied load from 5 to 100 N (contact pressure ranged between 130 MPa and 1.3 GPa). The instrumentation of the tribometer enables continuous measurement of the normal and tangential forces, vertical displacement of the contacting samples, temperature in the vicinity of the contact zone, partial pressure and gas composition in the test chamber and electrical contact resistance. The design difficulties have been exposed and the chosen technological solutions are presented. A test has been carried out to validate the tribological device.

Keywords: Tribometer design; Radiative heating; Secondary vacuum; Surface reactivity

1. Introduction

This paper describes a specific tribological tool devoted to the study of surface and interface mechanisms under precise controlled mechanical, thermal and physicochemical conditions. Indeed, a recurring difficulty in formalizing dynamic models for interfacial processes is due to insufficient knowledge of the complex interactions between the local mechanical and thermal conditions with regard to the environment and physicochemical reactivity of rubbing surfaces. The decoupling and structuring of these phenomena require accurate control of both thermal and environmental parameters in order to analyse accurately their influence on the general tribological performances and durability of the studied materials.

The physicochemical mechanisms solid/solid (adhesion) and solid/environment (oxidation) of the sliding contacts remain inadequately correlated to the reactivity studies that consider only one solid surrounded by a given environment. Therefore, tribological tests where conditions of reactivity in the contact zone are precisely controlled (in terms of oxygen partial pres-

sure, of humidity ratio, or of vacuum and temperature) seem to be the only method to make effective progress in the understanding of superficial mechanical/thermal/physicochemical interactions yielding in a sliding contact. The final objective is to offer more reliable materials that fit with specific industrial conditions.

Most tribometers impose only mechanical conditions (load and speed) into the contact. Tribometers proceeding to an effective control of the thermal and physico-chemical aspects (atmosphere and/or temperature) are not so numerous because of their technological complexity. Such devices usually have a tight test chamber in which a secondary vacuum can be reached and where different inert or reactive gases (air, O₂, N₂, . . .) can eventually be injected. In addition, a heating element surrounds the test chamber or samples to simulate temperature changes, i.e. the reactivity conditions.

A first category of environmental tribometer controls only the chemical conditions in the contact. These types of tribometer usually work at room temperature and reaches a vacuum around 10^{-6} mbar inside the test chamber. The tightness of chamber requires magnetic coupling to ensure the rotation of the disc [1]. Furthermore, small friction devices were introduced into SEM or XPS to take advantage of the high vacuum performances

* Tel.: +33 562 44 27 00/28 31; fax: +33 562 44 27 08.

(UHV), observations and possible in situ analyses made possible by such apparatus [2,3]. These specific tribological apparatus are limited to reciprocating displacements under low load (0.06 N) and velocity (0.05 mm/s).

A second category of environmental tribometer controls both chemical and thermal conditions. The introduction of a heating element involves advanced technological solutions, especially for bearings and joints. In some cases, the friction behaviour was studied at low temperature (down to 77 K) in various gaseous environments at low pressure (2×10^{-7} mbar) [4]. The applied loads can be carried out up to 100 N and the velocities ranged between 0.01 and 5 m/s. In other cases, tests were performed at high temperature (greater than 900 °C and up to 1400 °C) in vacuum. Resistive furnaces are usually chosen because they involve a good thermal homogeneity in a large studied zone [5–7]. Tribological tests under overpressure of Ar, N₂ or O₂ were also performed at 1000 °C [8]. Although easier to install, inductive furnaces are less used in case of controlled atmosphere. This type of heater is generally chosen for applications in which only one antagonist must be heat, as for analysing the tribological behaviour of hot rolling or forging. However, this technological solution was adopted for the Semenov’s adhesiometer (2000 °C/vacuum 10^{-4} mbar) [9].

2. Tribometer design

2.1. General description

The device meets the following technical specifications. The contact has a pin-on-disc configuration and works in air or in vacuum conditions. During the test, the pin remains fixed while the disc moves at a constant rotating speed. The applied loads and the sliding velocities range respectively from 1 to 100 N and 0.1 to 1.5 m/s. Tests can be performed from room temperature to

900 °C while air pressure ranges from atmospheric conditions to 10^{-6} mbar.

The apparatus is divided into three parts separated by two horizontal plates: the upper part, the central part and the lower part. The lower plate is fixed to the frame and is considered as the reference plane. The upper plate can be lifted up and down along four driving shafts to allow the setting of the samples (Fig. 1).

The upper part is devoted to the loading system and measuring sensors (torque, normal force and vertical displacement). The different sensors are located inside the vacuum chamber. The load is applied by gravity using a lever arm out of the test chamber and then transmitted to the loading shaft through an air-proof metal bellow. As the load is transmitted entirely by rigid components (the flexible bellow only ensures a tightness function around the loading shaft), the actual applied load sustained by the samples remains independent from the atmospheric pressure.

The lower part ensures the rotation of the lower shaft using an electrical motor (1.55 kW) associated to a frequency converter. A magnetic junction transmits (without contact) the rotating movement to the lower shaft through a non-magnetic sheet. In contrast to the upper loading shaft, the lower driving shaft is free in rotation and stopped in translation.

The central part is organised around the test chamber where pin and disc are in contact (Fig. 2). The upper loading shaft carries the pin and the lower rotating shaft drives the disc. These two coaxial shafts are guided by two pairs of polymeric plain bearings able to work under vacuum conditions without lubrication. The heating system, the vacuum enclosure and the cooling elements surround the test chamber made of a Waspalloy cylindrical sheet.

The apparatus frame is constituted of square welded tubes to rigidify the structure. The size of the whole system is a 70 cm square reaching a height of 180 cm for a mass of around 150 kg.

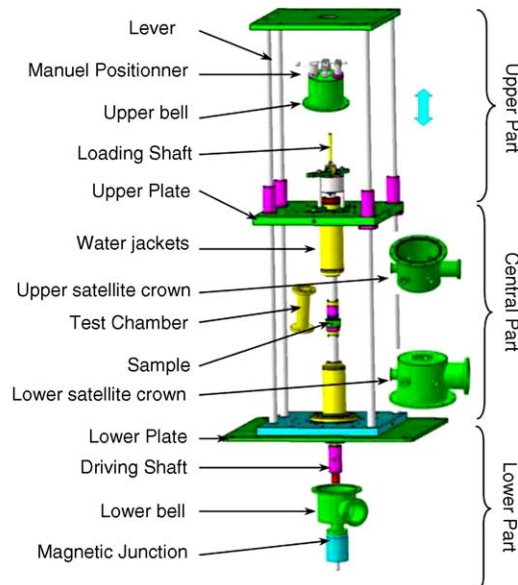

Fig. 1. General view of the environmental tribometer and diagram showing the internal elements of the device.

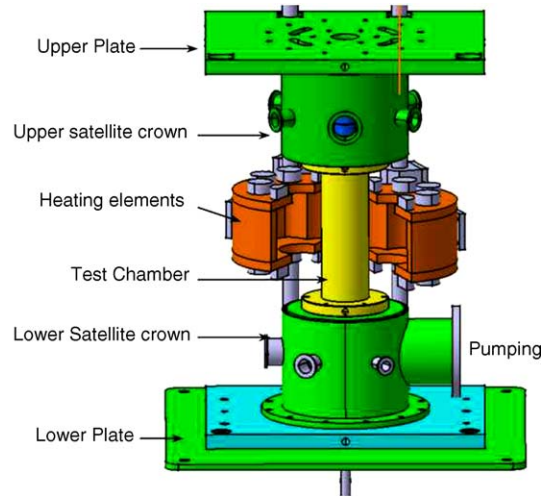

Fig. 2. View of the central part of the tribometer showing the test chamber surrounded by the radiative furnace and the two satellite-crowns containing the driving and loading shafts and the water jackets.

2.2. Environmental controlling aspects

The heating system is a radiative furnace specially developed for this application. It includes eight halogen lamps of 1 kW which requires a current intensity of 42 A. Each lamp is situated out of the test chamber at the focus point of a half-elliptical housing. This furnace (115 mm in height and 230 mm in diameter) is divided in two half-symmetrical parts for opening when samples must be introduced in the test chamber. A temperature of 900 °C inside the test chamber is reached in 7 min in vacuum (Fig. 3). This fast rise in temperature avoids transient oxidation stages before reaching the temperature of study. The external surface of the furnace and the lamp connections are continuously cooled by a water circulation network. Water jackets also protect plain bearings from heat conduction along the two shafts. They ensure these guiding components a temperature lower than 100 °C.

The air-proof zone of the device includes the test chamber, the two satellite-crowns situated above and below the test chamber and the two bells closing the device on the top and at the bottom. Vacuum rings ensure the tightness of the whole system. A first vane pump linked to a second turbo-molecular pump, reaches

a residual pressure of 10^{-6} mbar (secondary vacuum) in almost 5 h. Pressure measurements were performed for primary pumping and secondary pumping in two different places of the device: in the lower satellite-crown just at the level of the pump, and in the upper satellite-crown beyond the test chamber (Fig. 4). A good vacuum homogeneity is confirmed in the whole system, even at low pressure. Specific gasses (oxygen, argon, ...) can be injected into the test chamber during the test.

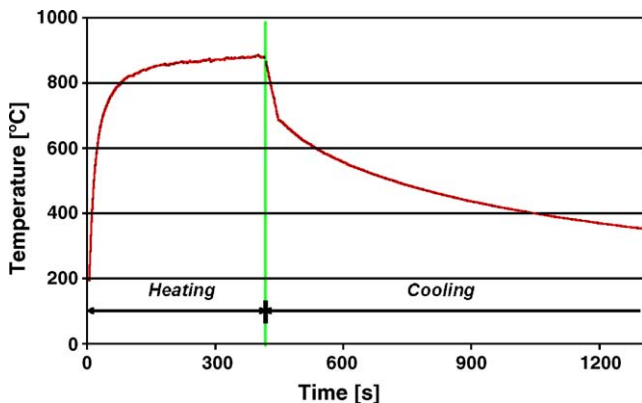

Fig. 3. Performance of the heating elements. A temperature of 900 °C is reached in 7 min.

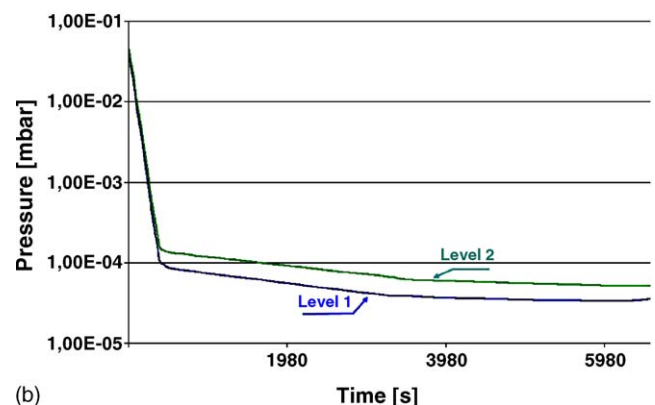
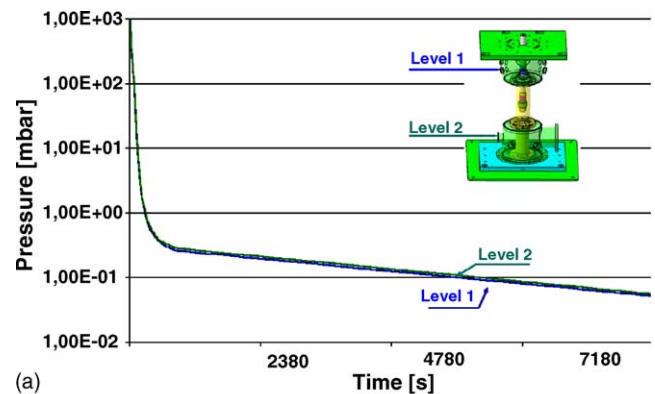

Fig. 4. Pressure measurements performed at the level of the two satellite-crowns. Comparison in the case of primary pumping (a) and secondary pumping (b).

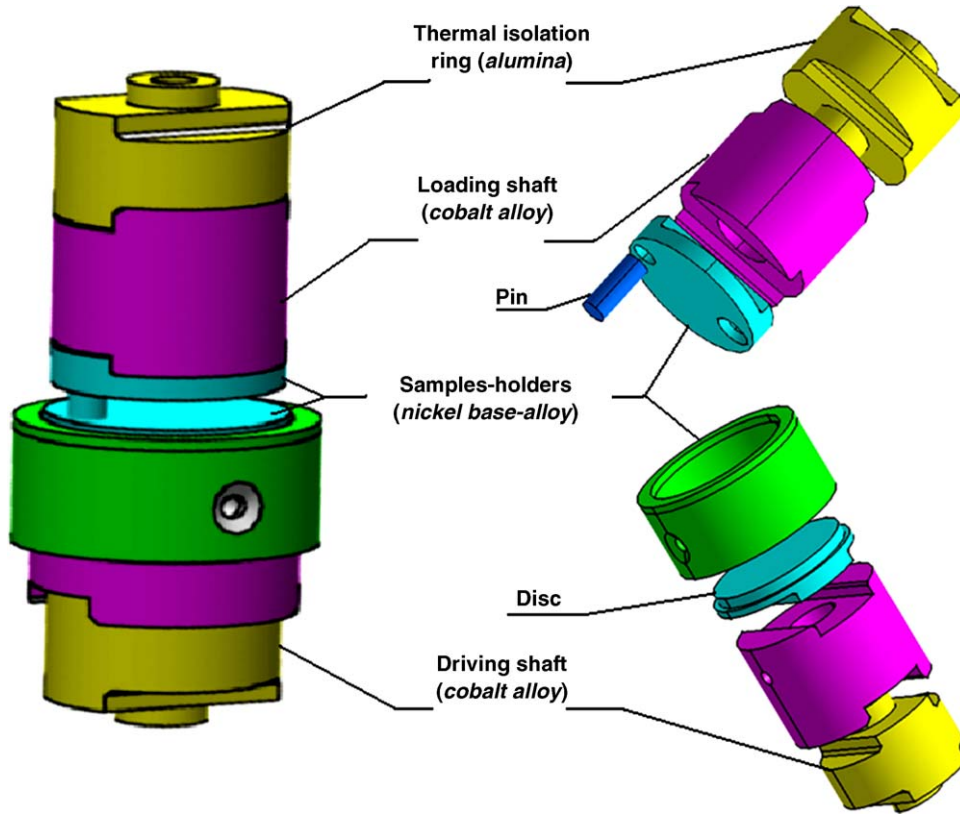

Fig. 5. Diagrams of the sample assembly showing the pin and the disk with their sample-holders brought up on the loading and the driving shafts.

2.3. Samples and instrumentation

The pin has a cylindrical shape of 6 mm in diameter. The disc is 37 mm in diameter and the surface of contact is then 28 mm². The samples are positioned on sample-holders made of nickel-base alloy. The pin is fretted into the upper sample-holder and the disc is fixed by a tubular sample-holder directly on the driving shaft. Two screws made of nickel-base alloy joint each sample-holder to its respective shaft (Fig. 5). The heated extremities of the loading and driving shafts are made of a cobalt-base alloy and linked by an insulating ceramic element to the other part of the shafts made of steel. Access to the samples requires the removal of the test chamber and the raising of the upper part of the device. This operation is realised with the help of counter weights where the upper plate is guided by four plain bearings.

A large number of measures are possible in situ with this apparatus. The friction torque (and then the coefficient of friction) and the applied load are recorded simultaneously with a single combined sensor. This sensor is situated in the upper bell at the top of the loading shaft between the loading system and the plain bearings. For dry tests, friction induces by the plain bearings is negligible. Displacement sensor measures the height changes of the upper shaft caused by thermal expansion of the shafts wear of the samples or debris loading capacity during the test. Several thermocouples are placed in the furnace and in the test chamber. One thermocouple is for the furnace regulation and two thermocouples are used for measuring the temperature of the samples themselves. A pressure sensor situated in

the lower satellite-crown controls the vacuum level in the sample vicinity. A gas analyser (mass spectrometer) situated in the upper satellite-crown provides directly the partial pressure of oxygen and other inert or reactive gasses (Fig. 6). A measurement of the contact resistance between the two rubbing samples is available. This measure requires electrical isolation of the two samples enabled by ceramic rings made of alumina, a rotating collector on the driving shaft and a current generator. All sensors are working in vacuum so all these measurements require their own tight connection. These connections are distributed round the two satellite-crowns. Wear measurements are obtained by profilometry after testing.

3. Experiments

Tests at atmospheric pressure, primary vacuum (0.13 mbar) and secondary vacuum (7.2×10^{-5} mbar) have been conducted with a commercially nickel-base alloy (Inconel 718) in homogeneous configuration at a sliding speed of 0.75 m/s, an applied load of 15 N and a temperature of 650 °C. Prior testing, the specimens were polished (mirror polishing) and ultrasound cleaned in detergent and in ethanol for 10 min. Test duration was 20 min.

The coefficients of friction recorded in different environment conditions suggest distinct behaviour at high temperature (Fig. 7). At atmospheric pressure, the coefficient of friction is rather low ($\mu \approx 0.5$) and slowly decrease with time after a very short transitory period of a few seconds where the coefficient of friction was very high ($\mu \approx 1.5$). In primary vacuum, the

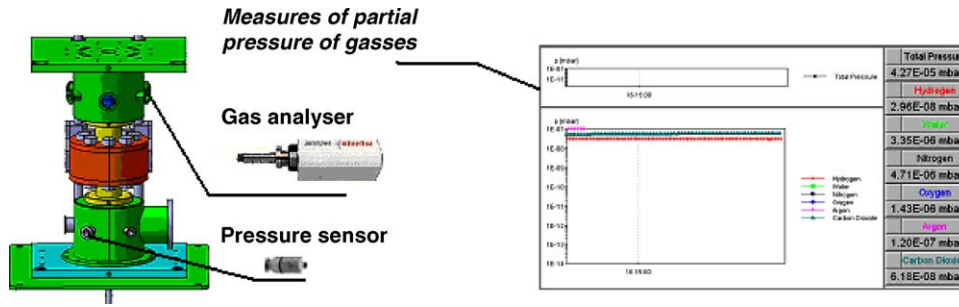

Fig. 6. Continuous analysis of gas composition with the mass spectrometer.

coefficient of friction remains high ($\mu \approx 1$) but very constant during the whole test. In secondary vacuum, the coefficient of friction is high ($\mu \approx 1.2$) less steady and increase with time. The two wear rates measured in vacuum are lower than at atmospheric pressure and they are estimated to 0.002 and 0.050 $\mu\text{m}/\text{mm}^3$ respectively.

SEM observations showed that severe scratching and grooving occurred on the sliding surfaces in the various atmospheres. At atmospheric pressure, wear particles were compacted onto the worn surfaces to create thick and irregular transfer layers (Fig. 8a). In vacuum, the worn surfaces are smoother smearing

and layer deformation is higher (Fig. 8b and c). Several studies have shown that these changes are associated with the establishment of compacted layers made of a mixture of oxidised films and partially oxidised particles on the sliding surfaces. In fact, Jiang and Stott [10–12] have studied the tribological behaviour of a nickel-base alloy, Nimonic 80A on a like-on-like pin-on-disc reciprocating wear rig at temperature from 20 to 600 °C. A transition in wear rate from severe to mild wear is observed during the sliding which is accompanied by the development of wear-protective layers. In this case, the friction coefficient decreases like the case of the atmospheric test

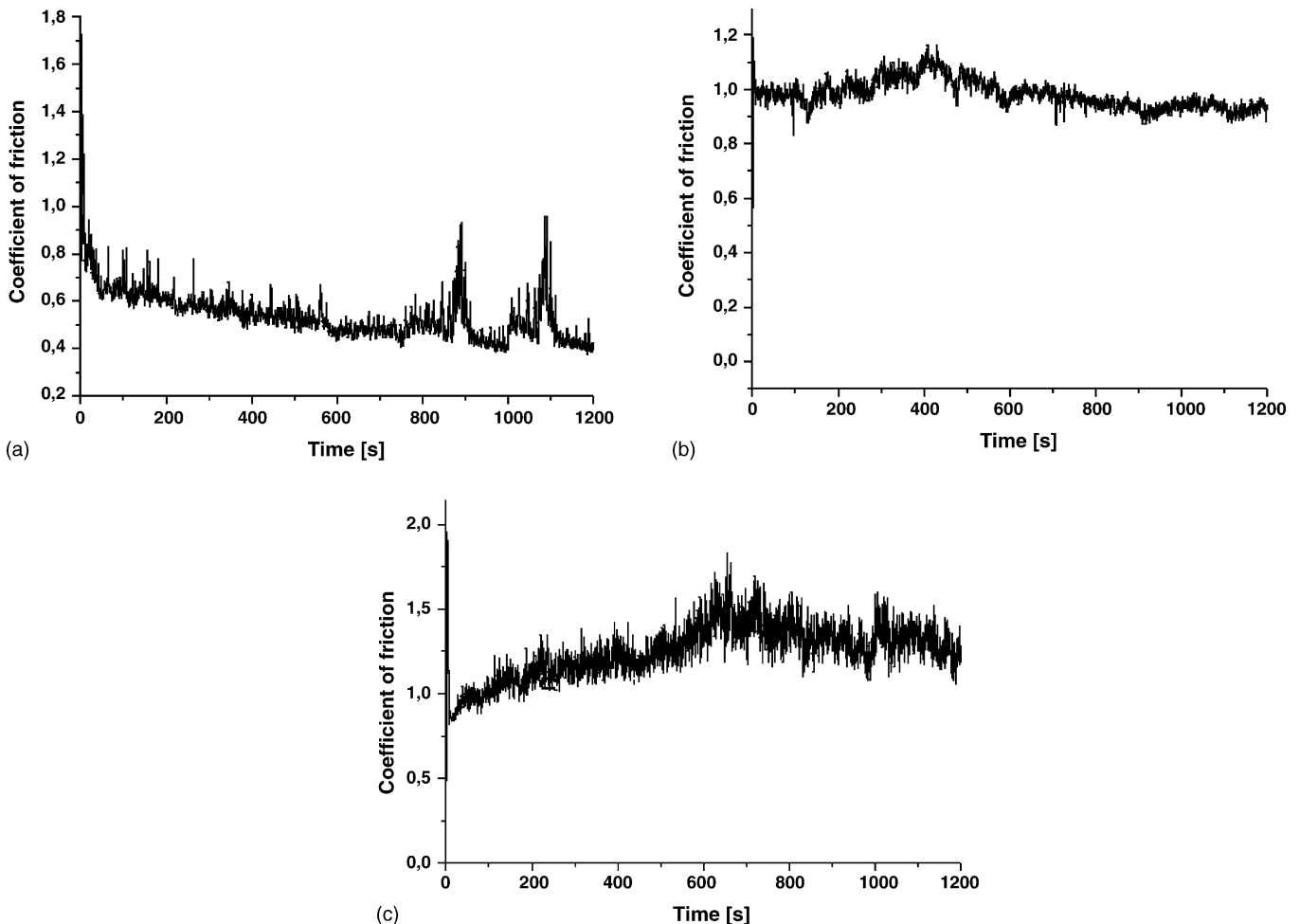
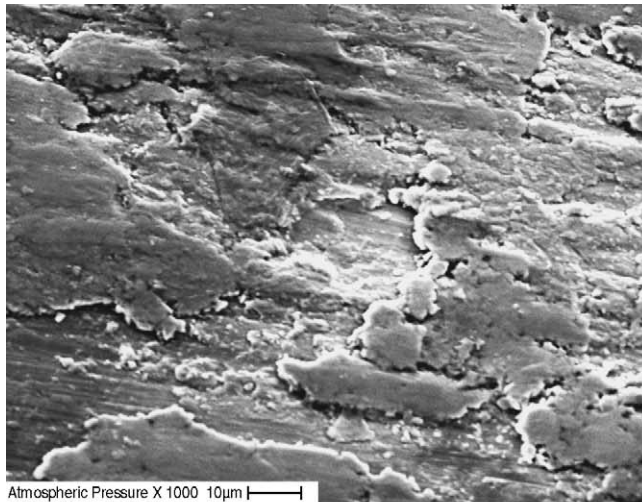
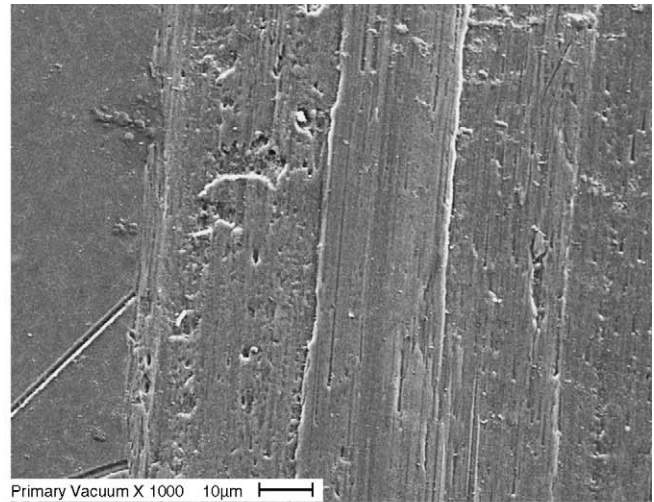

Fig. 7. Friction behaviour of Inconel 718 in homogenous contact at 650 °C, 15 N and 0.75 m/s, (a) at atmospheric pressure, (b) in primary vacuum, (c) in secondary vacuum.



(a)



(b)

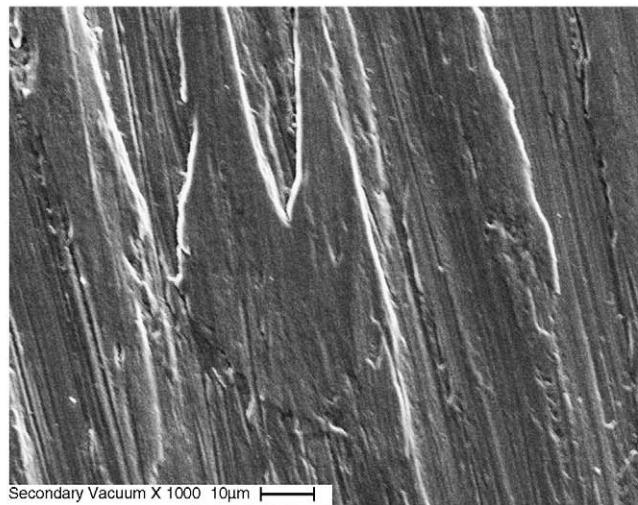

(c)

Fig. 8. Scanning electron micrographs of the wear scars on the disc (Inconel 718, 650 °C, 15 N, 0.75 m/s) (a) at atmospheric pressure, (b) in primary vacuum, (c) in secondary vacuum (same magnification).

of this study. The kinetic of formation of such layers essentially depends on the oxidation kinetic that is on the oxygen partial pressure.

4. Conclusion

A new environmental tribometer was developed for studying the mechanical, thermal and chemical interactions and their incidences on the durability of rubbing materials. It allows tests to be performed in a pin-on-disc configuration at controlled temperature (up to 900 °C) and atmosphere (down to 10^{-6} mbar). Particular attention has been given to the resolution of guidance and tightness problems, to the original heating mode and cooling system, and to the loading and driving functions. Continuous measurements of coefficient of friction, vertical displacement, temperature near the samples, pressure and nature of residual gases (gas analyser) are available. The tests performed on a nickel-base alloy at 650 °C under various environmental conditions of air pressure (ambient atmosphere, primary and sec-

ondary vacuum) and their reproducibility permitted to validate the performances of the device.

Acknowledgements

The authors are very grateful to their colleagues of the CRITT of Toulouse (Regional Centre of Innovation and Technology Transfer/France) and particularly to J.-C. Salabura and C. Ducroux for their valuable help in the design of this environmental tribometer. We are also indebted to the Regional Council of Toulouse for its partial support of this work.

References

- [1] K. Nakayama, T. Kobayashi, Effect of dissolved oxygen on the formation of iron fluoride, friction and wear in an iron/iron frictional system under perfluoropolyether fluid lubrication, *Wear* 198 (1–2) (1996) 52–57.
- [2] J.M. Martin, T. Le Mogne, M. Boehm, C. Grossiord, Tribochemistry in the analytic UHV tribometer, *Tribol. Int.* 32 (1999) 617–626.

- [3] T.R. Bates, K.C. Ludema, C. Brainard, A rheological mechanism of penetrative wear, *Wear* 30 (1974) 365–375.
- [4] Y.L. Ostrovskaya, T.P. Yukhno, G.D. Gamulya, Y.V. Vvedenskij, V.I. Kuleba, Low temperature tribology at the B. Verkin Institute for Low Temperature Physics & Engineering, *Tribol. Int.* 34 (4) (2001) 265–276 (historical review).
- [5] C. Palmonari, L. Esposito, E.H. Toscano, Tribological tests in ceramics materials development: a pin-on-disk tribometer for high temperature and controlled atmosphere, in: *Conference Evolution of Advanced Materials*, Milano, Italy, 1989, pp. 633–638.
- [6] F.J. Carignan, High Temperature Tribometer, Final Report, Aero Propulsion and Power Directorate Wright Laboratory (AFSC), 1992, pp. 1–22.
- [7] H.E. Sliney, C. Dellacorte, A new test machine for measuring friction and wear in controlled atmospheres up to 1200°C, *Lubr. Eng.* 47 (4) (1991) 314–319.
- [8] F. Platon, *Standard Tribological Tests for Engineering Ceramics Ceramic Materials and Components for Engines*, D. Keram. Ges. Publi., 1986, pp. 735–757.
- [9] A.P. Semenov, Tribology at high temperatures, *Tribol. Int.* 28 (1) (1995) 45–49.
- [10] F.H. Stott, High-temperature sliding wear of metals, *Tribol. Int.* 35 (8) (2002) 489–495.
- [11] F.H. Stott, M.P. Jordan, The effects of load and substrate hardness on the development and maintenance of wear-protective layers during sliding at elevated temperatures, *Wear* 250 (1–12) (2001) 391–400.
- [12] J. Jiang, F.H. Stott, M.M. Stack, The effect of partial pressure of oxygen on the tribological behaviour of a nickel-base alloy, N80A, at elevated temperatures, *Wear* 203–204 (1997) 615–625.