

Optimization of electricity / hydrogen cogeneration from generation IV nuclear energy systems

A. Gomez^{a,c}, C. Azzaro-Pantel^a, L. Pibouleau^a, S. Domenech^a, C. Latgé^b, P. Dumaz^c, D. Haubensack^c

^a *Laboratoire de Génie Chimique (CNRS UMR 5503), 5 rue Paulin Talabot, 31106 Toulouse Cedex 1, France, {Adrien.Gomez, Catherine.AzzaroPantel, Serge.Domenech, Luc.Pibouleau}@ensiacet.fr*

^b *CEA Cadarache, DEN/CAD/DTN/DIR Bât 710, 13108 St Paul Lez Durance, France, Christian.Latge@cea.fr*

^c *CEA Cadarache, DEN/CAD/DER/SESI, Bât 212, 13108 St Paul Lez Durance, France, {Patrick.Dumaz, David.Haubensack, Adrien.Gomez}@cea.fr*

Abstract

One of the great motivations of studying and developing Generation IV (Gen IV) reactors of VHTR (Very High Temperature Reactor) design concept is their capacity to efficiently produce both electricity and H₂ (hydrogen). This study aims at developing an optimization methodology for cogeneration systems of H₂ and electricity, from Gen IV nuclear reactors, with respect to energy constraints, economics and conjuncture in term of demand. It lies within a scope of a collaboration between the Laboratoire de Génie Chimique (Toulouse, France) and the Commissariat à l'Energie Atomique (CEA, Cadarache, France) in order to compare various cogeneration systems from both energy and economics viewpoint.

This paper presents the results of an optimization study based on the “minimal destruction of exergy” or “exergy loss” concept. This criterion, used within the framework of a mono-objective genetic algorithm optimizer, was applied successfully to electric and heat production from Gen IV systems.

Keywords

Electricity; Hydrogen; Cogeneration; Gen IV nuclear systems; Exergy loss concept; Genetic algorithm

1. Introduction

Hydrogen is currently viewed as one of the energetic vectors that will replace traditional fossil fuels in the XXIth century. Although the transition is assumed to be progressive, innovative technologies for a massive production of H₂ have to be investigated.

The VHTR (Very High Temperature Reactor) concept, considered as the nearest-term reactor design, can indeed be coupled on the one hand, with innovative electricity-generating cycles and, on the other hand, with massive H₂ production processes. Thus, due to a high exit core temperature (at least 950°C) reached by helium used for cooling,

VHTR is dedicated to the cogeneration of electricity and hydrogen by Sulphur-Iodine (S-I) thermochemical cycles [1] or by High Temperature Electrolysis of steam water. Globally, these processes require the simultaneous supply of electricity and heat at high temperature.

In this perspective, simulation tools of thermal systems were previously developed by the CEA (Commissariat à l'Énergie Atomique, Cadarache, France), i.e., CYCLOP for thermodynamic cycle modeling and COPERNIC, for the preliminary design of system components. These codes allow to model innovative energy production systems for given operating conditions while taking into account the influence of classical variables : exchanger effectiveness, pressure ratio and isentropic effectiveness (compressor, turbines ...), pressure loss...

This paper is divided into 3 sections: the first section is devoted to the system presentation. Indeed, it must be pointed out that formulations based on the computation of "1st principle efficiency" criteria are particularly inadequate to the formulation of cogeneration problems and, more generally, to the production of two distinct energy forms: this is why the concept of "minimal destruction of exergy", representing the losses of "useful" energy, described in the second part, was chosen here, since it can be applied easily to energetic optimization of any system.

In the third part, the choice of a mono-objective genetic algorithm is briefly justified and applied to the optimization of energy distribution systems. Finally, typical results are presented and show that the concept of "Exergy" is particularly well-fitted to optimize successfully electric and heat distribution of generation IV systems.

2. Cogeneration of electricity and heat for H₂ production: system description and optimization problem

The simultaneous production of electricity and H₂ involves the study of both production and primary distribution systems of energy (electricity and heat). The VHTR nuclear reactor (Fig. 1) distributes power to two parallel systems. The former is a Gas Turbine Modular High temperature Reactor (GT-MHR) based on a Brayton's cycle type, with heat recovery at turbine and coolers exit before Low and High pressure compressors. The latter is a heat distribution loop for five thermal demands of the S-I cycle. Helium coolant in this loop is heated by the so-called Intermediate Heat EXchanger (IHX). Pressure losses on the IHX are compensated by using electrically supplied blowers. The mechanical and isentropic efficiencies are fixed for the turbines and compressors, as well as the effectiveness and pressure losses for the exchangers.

From the analysis of the system degree-of-freedom, the following optimization variables were selected:

- Turbine pressure ratio (rP Turbine)
- Low Pressure Compressor pressure ratio (rP Comp LP)
- Heat delivery for H₂ production (it will be considered that the thermal demand is purely proportional to hydrogen production).

A preliminary S-I plant design showed that the electrical (respectively thermal) consumption must be fixed to 10 MW (respectively 60 MW) for a total production of 100 mole/s of H₂.

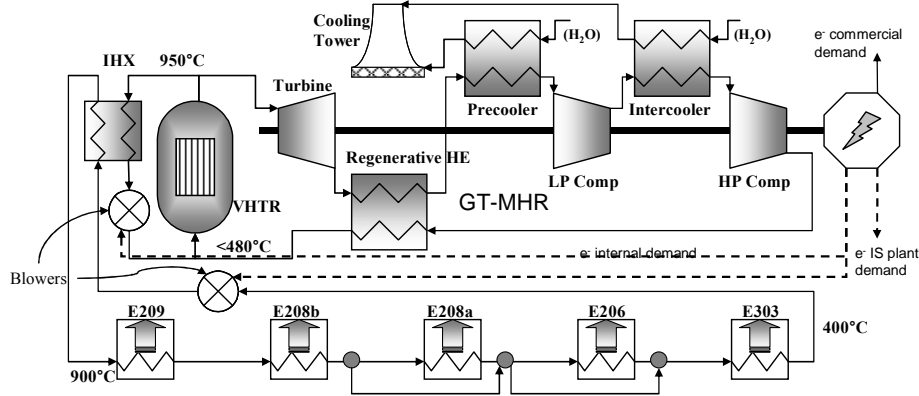

Fig. 1. Cogeneration of Heat and Electricity with a VHTR nuclear reactor (600 MW)

The choice of the energy criterion is of great importance both for the system optimization and the comparison of alternatives for electricity and H_2 production. If only the 1st principle (for instance $[\text{High Heating Value of } \text{H}_2 + W_{\text{elec}}] / W_{\text{therm}}$) is considered, it is impossible to describe the system completely from a thermodynamic point of view. The entropic losses, often neglected in practice, are responsible for irreversible losses of “useful energy”: their minimization thus results in an increase in energy conversion.

This is why the concept of “exergetic losses” minimization must be applied to the considered cogeneration system (heat and electricity for H_2 production).

3. Exergy losses concept for a cogeneration system

Let us consider an open system (Fig. 2) which receives/provides electrical, mechanical and heat power and also exchanges thermal power with heat reservoirs, and among them, particularly, the atmosphere. The whole internal transformations of the system may generate irreversibilities which may decrease. An energetic balance can be applied to any type of component (exchangers, compressors...) in an individual way, but can also be used at the borders of the system according to a multiscale approach: it is typically the case for the heat released to the atmosphere (term “d” for cooling systems). According to Gouy [2], the difference between the maximum energy that can be used (term “c” eqn (1)) and the energy that is produced (term “a” & “b” eqn (1)) has to be minimized. By regarding the atmosphere as an energy potential reference, the application of Gouy’s principle leads to equation (1), the so-called “exergetic balance”. Consequently, the maximization of the “a+b” quantity is equivalent to minimize the “d+e” term representing the “exergetic losses” or the “lost available work”. This formulation is a thermodynamical rigorous way to compare various forms of produced energy, with the objective to maximize them and is adopted in the following optimization study.

$$\underbrace{Q_s \left(1 - \frac{T_0}{T_s} \right)}_a + \underbrace{W_{\text{meca}} + W_e}_b = \underbrace{\sum_n Q_n \left(1 - \frac{T_0}{T_n} \right)}_c - \underbrace{\left(\sum_j m_{\text{Out}}^j e_{\text{Out}}^j - \sum_i m_{\text{In}}^i e_{\text{In}}^i \right)}_d - \underbrace{T_0 \cdot S_{\text{Irr}}^{\text{Int}}}_e \quad (1)$$

m : mass flow rate (kg/s) h : enthalpy (J/kg) s : entropy (J/kg/K)

T : temperature (K) Q : heat power (W) W_{meca} : mechanical power (W)

W_e : electrical power (W) $e = h - T_0 s$: flow exergy (J/kg)

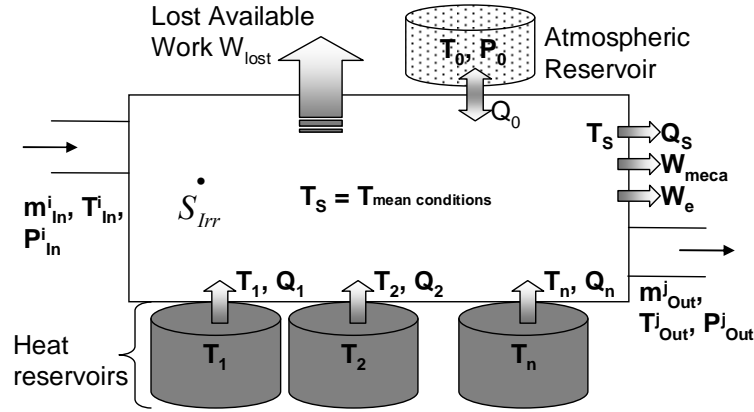

Fig. 2. Open thermodynamical machine producing various type of useful energy

4. Case study and results

Thermodynamic modelling of the investigated cycle is performed using the combination of the abovementioned CYCLOP simulator with a genetic algorithm at the upper optimization level, designed for mono-objective mixed integer constrained problems. By lack of place, the principles of development of this optimization solver will not be presented here. Let us only mention that genetic algorithms are particularly well-fitted when complex thermodynamic models are involved in the computation of the fitness function with many constraints to manage. Both codes are developed in VBA language. Two cases are studied here. In case 1, only one S-I plant with a continuous variable H_2 production (according to 100 H_2 mole/s plant requirements) is considered. Case 2 embeds case 1 with an additional variable, i.e. the plant (100 H_2 mole/s plant) number in order to represent the modular organisation of real cogeneration system. Both cases using the variables defined in paragraph 2.

Equation (1) is applied to the whole set of components. From the system point of view, the exergy (heat) loss on the precooler and intercooler are considered using the term “d” of the equation (3). Internal irreversibilities are computed using the term “e”.

The objective of such a coupling consists in maximizing the energy production including heat and electricity, while remaining electricity autonomous for the given requirements (S-I plants, blowers), limiting efficiency at 95% for the regenerative heat exchanger, and minimizing exergy losses (term “e+d” of equation (1)).

The energy losses for case 2 (Table 1) can be attributed to a higher activity of the generating cycle, inducing stronger irreversibilities compared to case 1. Taking into account the efficiency of the gas turbine (49,6% for the GT-MHR) and since any transformation of an energy form into another one (for instance, heat into mechanical energy) generates a higher entropy than a same energy exchange value at the same state (heat exchangers), it can be predicted that the minimization of the exergetic losses on the coupling, will favour the distribution of heat instead of electrical production, within the limit of the constraints of electricity autonomy. These results are in agreement with physical considerations for both studied cases. In case 1, the exergetic losses on the production of electricity (30.01 MW) are 1.94 times more important than on the heat

distribution network (15.49 MW). Case 2 exhibits a higher loss ratio (2.18) for a loss of 32.5 MW, for the electricity production, and 14.91 MW for the heat distribution. Case 2 considering the plant number as a variable of optimization prevents from using all the thermal available power. The additional thermal power is absorbed by GT-MHR cycle by generating more important exergy losses, which explains the variation observed in case 1. The lowest H₂ production induced in case 2 implies that all the thermal power was not used. The additional power was converted into electricity, according to equation (1), but producing more exergy losses.

Table 1. Optimization results for e⁻ / thermal energy cogeneration with VHTR source

Components	Exergetic losses (MW) case 1	Exergetic losses (MW) case 2
VHTR reactor	7.28	7.27
Turbine	4.92	5.37
Recovery Exchanger	3.86	4.19
Precooler	8.60	9.02
LP Compressor	3.45	3.82
Intercooler	5.48	6.16
HP Compressor	3.70	3.94
IHX + blower	8.78	8.45
S-I Heat distribution	6.71	6.46
Cooling water	1.50	1.76
Total Exergy losses	54.27	56.46
rP Turbine	3,288	3,315
rP comp LP	1.837	1.870
H₂ production (mole/s)	726.67	700.00 (7 S-I plants)
e⁻ production (MW)	272.10⁻⁶	10.93

5. Conclusions

This study has shown that the minimization of a criterion based on exergy loss is particularly significant to develop comparative studies between various strategies of electricity-hydrogen cogeneration. Further work will be now developed to extend the formulation to the computation of the exergy losses assigned to H₂ production plants. Of course, this criterion minimization will tend towards thermodynamic ideality. It will be thus necessary to consider simultaneously both investment and operational costs of the system: multicriteria optimization is now under investigation to obtain a technico-economical compromise.

6. References

1. S. Goldstein, Upper bound and best estimate of the efficiency of the iodine sulphur cycle, I. J. of Hydrogen Energy 30 (2005) 619
2. G. Gouy, Sur l'énergie utilisable (On usable energy), Journal de physique, 1889, 8 (2nd series) 501
3. A. I. Kiryushin, Project of the GT-MHR high-temperature helium reactor with gas turbine, Nuclear Engineering and Design 173 (19971) 119