

English version of an article for *Studia Semiotica* - online annual issue of SEECSS – New Bulgarian University – Sofia, 2011

BRAND AS AN ECONOMIC VALUE AND A SIGN: POSITIONING AS AN INSTRUMENT FOR CREATING MARKET DISTINCTIONS

DIMITAR TRENDAFILOV – PhD Candidate,

South-East European Center for Semiotic Studies – NBU, Sofia

dtrendafilov@nbu.bg

trendafilov.dim@gmail.bg

1. INTRODUCTION

The word "brand" comes from Old Norse /brandr/ and means ‘to burn’ and ‘to mark out’. The roots of the brand can be traced back to ancient times when marking was originally used for denoting ownership of logs and different pets and marking signs of stonemasons who worked on the Egyptian pyramids, as well as for prints by masters of pottery in Greece and China. To date, the most frequently quoted definition is that of the American Marketing Association which states that a brand should be understood as a „name, term, sign, symbol, or design, or a combination of them intended to identify the goods and services of one seller or group of sellers and to differentiate them from those of competition” (quoted in Keller, 1998: 2). Based on this idea, in article 9, par. 1 of the *Law of Trademarks and Geographical Indications*, the Bulgarian legislation extends the concept and defines the brand as "a sign capable of distinguishing goods and services of one person from those of other persons and can be represented graphically. Such signs can be words, including personal names, letters, numerals, drawings, or figures, the shape of the goods or their packaging, a combination of colors, sound signals or any combination of such signs.” (www1.bpo.bg).

A quick glimpse into economic history shows us that the evolution of markets is driven by scarcity and limited production of mass consumer goods to a super choice.¹ It is in the regime of

¹ According to a large proportion of researchers – economists, futurists and marketers, at the beginning of the information age and the announcement of the knowledge economy, the capitalist system has undergone a revolutionary change, which may be equal to the invention of the steam engine or electricity. Although many factors have prevented the world from developing evenly, and in many parts of the planet remnants of the feudal system are observed, thanks to the globalization processes the developed countries and the powerful international corporations exert a strong influence on the unification of the mechanisms of economic development, in the center of which is not so much production itself but rather the single user. This has its consequences, eloquently described by Jeremy Rifkin: „In the networked economy, characterized by a shorter product life and a continually expanding flow of goods and services, human attention, rather than material resources, is what becomes insufficient.“ (Rifkin, 2001:107).

the super choice that the brand has an increasing role as a clearly articulated promise for added value of the purchase and as an offer for the acquisition of benefits. It appears simultaneously the reason and the instrument of an undeclared communication war with a global range, characterized by a much bigger diversity, flexibility and innovativeness in the approach towards the potential „victims“, than those in the conventional conflict. This is a war for a place on the shelf in the store, for the attention of the customer, for his admiration and loyalty, for his compassion and positive evaluation in the course of his whole life (see Rifkin, 2001: 109-113). Every day each one of us participates actively in shaping the choice, diversifies it and modifies it. As a result, the lifestyle of the products is constantly decreasing, the information regarding prices, quality and manufacturers is accessible to the most unprepared consumer and retaining of the interest of the customers is turning into a task of paramount importance for the marketing departments. In such an environment the brands that are born and developed perform the complex role of a reference point in the variety of goods and services, see to the emergence of new needs which must be satisfied and aim at offering the best under the pressure of the ruthless competition.

Today we can see how new markets are born (unthinkable only 20 years ago), while entire industries and traditional manufactures are going down. In the information age it is very hard to determine what is creating more economic value – the production of physical goods or the creation of software and supply of services. In *The Age of Access* Jeremy Rifkin attempts to resolve this dilemma by means of the following conclusion: „...the new era is more unmaterial and intellectual. This is a world of Platonic forms, of ideas, images and archetypes, of notions and fantasies. If the people in the industrial era were busy with the appropriation and transformation of matter, the first generation in the era of access is far more interested in brainwashing. (...) To be capable of extending your own intellectual presence, to be universally connected, so that you can influence the human consciousness and shape it – this is what motivates the business in every industry” (Rifkin, 2001: 63).

Thousands of pages are devoted to the phenomenon of trade mark with analyses and commentaries, descriptions and examples, but it seems that questions allowing further research and elaboration still remain. This is due to the fact that the brand and its management are constantly evolving at every single stage in the history of markets and business. By updating what was once a label of origin, branding has become a management process of *personalization* and a means of *differentiation*. The trade mark is already „living“ its own independent life, it has its own identity and acquires its own existence by which it is turning into a substitute for the product and even more so for the service. This replacement, however, is implemented somewhere in the bowels of the consumer's mind which, like mass production and communications, is undergoing

continuous and dynamic changes. This is why the goods-buyer relations can no longer be seen as lifeless and maximizing the benefit for both parties but rather has an emotional basis characterized by mutuality and respect. Today the brand is charged with many more symbols – social, cultural and personal – it is the new dominant in supply because it conveys messages about shared principles and promises for added value. Thanks to it, shopping has turned from a necessity for the procurement of products into an experience with a strong emotional intensity, proof of which are not only fashionable clothes and cars for every taste and status, but the fact that entire retail chains, show business and even our spare time are susceptible to branding.

The meaning of existence of the trade marks lies in the arrangement of a market (in product classes, categories and groups, in price levels) and the quality control over goods and services. In their totality, they create a clear and accurate picture in the mind of the consumer of what current offers from which to choose are, with respect to quality and quantity. According to renowned author Philip Kotler, the brand is the major issue standing in front of the product strategy of every company (Kotler, 2002: 356). He adds that the market power comes precisely from building their own brand or brands, thus in contemporary marketing the most distinctive skill of management teams is „their ability to create, maintain, protect and enhance the brand“ (ibid.). At this place it should be remarked that the brand draws its strength not from its own existence but from the market, to which it is dedicated, i.e. For it the major source of energy is not the product as a physical object itself but rather the targeted consumer (Fisk, 2008: 152). The main conclusion that follows is that marketing, by definition, is building the brand in the mind of the client – this is its main goal and source of inspiration. Without a strong brand policy all other marketing efforts are doomed to failure (Baleva, 2007: 172).

2. VALUE / SIGN

2.1. A curious fact is that when describing the main functions of a brand, many researchers put the emphasis on the claim that it is primarily a tool for **identification** of its owner and thus for **differentiation** of the offered goods or services from those of the competitors. From the history of the trade mark – from branding of horses and cows to the creation of a branded experience like *Disneyland* and *Niketown* - we can see that it has distinctive functions but they are changing as a result of the accumulation of meaning in it. The creation of distinctiveness on the market only appears the next, but not the last step in its evolution. Currently we are already talking about a new level – that of **brand equity**.

Graphically the growth of the brand can be represented as follows:

Fig.1

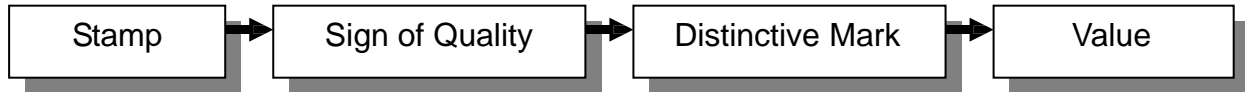

During the first stage of history marking was important for the *owner* so far as to show to the others that he had rights over the labeled objects or animals. Subsequently, the developing market has forced the manufacturer to come out of anonymity and provide his potential customers with an assurance that, for their money, they receive a product of a specific craftsman who supplies the demanded quality. With the advent of industrialization and multiplication of the number of brands the time of differentiation of individual producers has come. This is the product era, when the primary means for communicating it is the emphasis on its distinctive attributes and the benefits for the customer originating from them (Trout, Ries, 1981: 27). Gradually, besides the name and the logo, more attention is paid to the packaging and distribution of the brand. The client is now much more informed and demanding, which raises the bar for most manufacturers. Over time, however, "noise" in the market becomes more and more deafening, and the struggle for the consumers' attention starts to become a major task of any marketing specialist (Roberts, 2004, 33-34). This leads to the emergence of value,² provided that it is given by and for the consumer and is not physically produced by a particular company. In his main elaboration on strategic brand management Kevin Keller calls it **customer-based brand equity**, which incorporates „theoretical advances and managerial practices in understanding and influence consumer behavior” (Keller, 1998: 45). Typically, it has a "differentiation effect" because the knowledge built of the brand in the mind of the end consumer influences his choice. This choice is a reflection of the marketing efforts of the company-manufacturer³, considered to be as successful as a more favorable attitude a brand generates to its products, or without causing negative reactions by expanding its portfolio or by raising prices, or just stimulates a larger demand for the goods it offers in its distribution network (ibid.).

As can be seen from the proposed scheme (Fig. 2, Blagoev, 2003: 217), the brand value depends on factors such as favorable associations in the mind of the consumer who may be influenced by the brand through the marketing mix and a consistently constructed identity.

² We can find a confirmation in the following passage where the author is Peter Fisk (2008: 153): „A good brand is the one that you want to live your life with, in which you trust and count on, when everything around you changes ... Originally brands developed as labels for right of ownership. Today however, much more important is what they do to people, how they reflect their needs and attract them, how they formulate their aspirations and enable them to do more.”

³ „What makes an organization strong, are not the goods and services offered by it, but its position occupied in the minds of the consumers.” (Trout, Rivkin, 2002: 149).

Knowledge related to quality is based on previous experience of the customer with the production of the brand and recommendations received from the closest circle of people, and associations for reliability are a result of the enduring relationship of the consumer with the brand. According to David Aaker people “like the familiar and are prepared to ascribe all sorts of good attitude to items that are familiar to them” (Aaker, Joachimsthaler, 2000: 17).

Fig.2

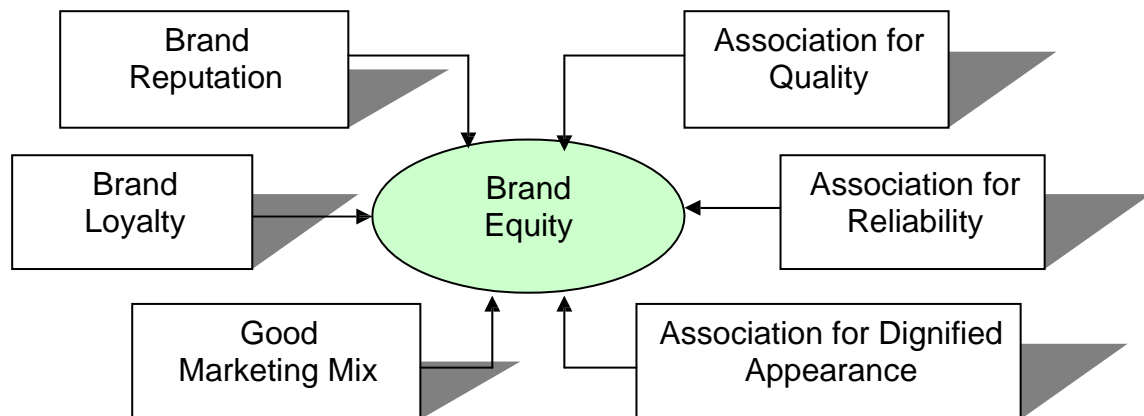

Loyalty in turn can be evoked if the brand performs "its promise" to bring to the buyer more than the price he will pay⁴. In Aaker's words it is "the heart" of any given brand's value. Concerning the price, the *size* of the group of loyal customers is important as well as the *intensity* of their loyalty (ibid.). It should be added however that these are inner circle variables. At the same time, the value is dominated by the specific conditions of the environment /outer circle/ in which the brand exists and develops. Here the key factors are the maturity of the market, the presence and strength of competition, the level and characteristics of consumer culture, living standards, cultural features, legal constraints, etc. (Blagoev, 2003: 217-218).

Brand value can also be seen through the prism of socio-semiotics because consumption is a form of exchange, just as communication is in its essence. This is an exchange of signs⁵ which convey a predominantly social message and are loaded with a specific meaning depending on the role that should be implemented - to show ownership or dominance, to reflect personal views and philosophy of the world, to approve or deny moral and social norms etc. According to Jean Baudrillard, the logic of consumption is the logic of the sign and diversity that

⁴ In *Customer Behaviour and Advertising* Anelia Petrova focuses on the positive emotional effects of using a product as the basis of „consumer loyalty“ (Petrova, 2004: 54).

⁵ Objects are signs, whether single or in combination; message bearers are their colors and shapes as well as their material and arrangement in space. The shape/commodity is an independent communication system which underpins the public one and is not a "supplement" or connotation. Here the role of the code is decisive, whether talking about material contents of production or immaterial contents of meaning (Baudrillard, 1996: 18 and 158).

must be understood separately from the economic logic of exchange value, as the latter is related to equivalence, rather than to generating differences (Baudrillard, 1996: 57). In this respect, the author explains further: "A user is never alone, as a talking man isn't either. Right here a complete revolution in the analysis of consumption should be made: just as *language does not exist because there is an individual need to talk ...* but first there is language not as an absolute, autonomous system, but as a simultaneous *structure of exchange* of sense itself, to which the individual intention to speak is connected. In the same way, consumption exists not because there would be an objective need for consumption, some sort of final orientation of the subject towards the object: there is social production in a system of exchange, of difference material, code of meanings and status values." (ibid.: 69).

2.2. When using the standard definitions of a brand, it is necessary attend to the fact that they do not contain the concept of added value of the brand, as no legal and/or economic definition is able to cover the present meaning of the brand, which is rooted in the minds of the consumers. These definitions have ceased to carry essential information about what is the brand at the stage of the "trademark" (see Roberts, 2004: 24-30), where the product needed protection in trade relations, and was not perceived as a specific commitment to its final customer⁶. In other words, they can explain what Coca-Cola is, but are unable to clarify the factors enabling the brand to be valued at 83.8 billion dollars⁷ without necessarily being the most delicious drink in its category (Baleva, 2007: 176).

The most accurate characterization of the brand is that it is neither a physical object nor a subject able to independently emit messages. By its very nature it is an "idea" entirely in the spirit of the quoted above by J. Rifkin and in a purely psychological sense it is no different from political or religious doctrines, giving orderliness of the world. The brand is a sender of a promise for the acquisition of benefits and added value. It is no accident that it is defined as a new totem or myth of the contemporary "tribe" (Evans, 1999: 12), as it is full of codes, sets patterns of behavior, forms estimates of the surrounding reality.

Like any idea, the brand should be shared and therefore its life is contained in the communication that occurs both in direction of the initiating organization to the audience, and among the addressees, i.e. its message can be transmitted by everything and everyone and very often it happens in public space beyond the control of the producer-owner of the brand (Bullmore,

⁶ The change in the meaning of the brand gives reason to some authors, including Velina Baleva (2007: 177), using the presence of the English word brand, to designate a wider concept which is common in marketing, unlike trade mark, which is part of the legal and business vocabulary. In the Bulgarian language, however, the semantic distinction is still hard to detect, despite the entry of the English terminology.

⁷ The figure varies according to the sources and years; for the example data from Interbrand in 1999 are used, quoted by David Aaker in *Brand Leadership*, 2000, p. 19.

2001, 2)⁸. The brand also exists by virtue of the widespread knowledge about it, it is pure information and therefore has no boundaries which could curb its influence but there are limitations to the perception, which can leave the message misunderstood. Actually, the term "branding" should not be considered from the perspective of the owner, just because he has put his stamp on it. Rather, the term describes the perspective of the addressee - that he has successfully received the message of the brand and reacts to its proposals. Only then will the brand perform its function which, as already mentioned, is to communicate itself.

To avoid a conflict in concepts related to the trademark, R. Abadzhimarinova focuses on a summary that combines both the benefits of the manufacturer who has an interest in legal protection and economic result from possessing a brand, and the viewpoint (value) of the consumer. According to her, brand is **"the mechanism for achieving competitive advantage for the company by differentiating its product, in which signs, distinguishing the brand, are primarily ... those that provide benefits for the client for which he is willing to pay"** (Abadzhimarinova, 2006: 48; bold is in quotation). As can be seen, the dignity of such observation on the contemporary significance of the trademark is contained in its designation as a "mechanism" i.e. *active, based on plans, strategies and particular actions, a process in attaining and maintaining of that state, in which the brand is distinguishable, familiar, offering benefits that the consumer wants to have for the relevant price*. Thus the brand emerges from the limits of statics and is perceived dynamically, as a series of managerial decisions that work in time for the brand to be turned from a sign and name into a market factor determining the choice of the target audience.

2.3. We will not find a place where the trademark *is*, nor a place where it is created or where it draws its energy from, because it is primarily a management approach and strategic plan, and not a manufacturing process in the strict sense of the word. The brand has no separate independent body, but rather has a body language (ibid.: 10), which is perceptible through all its marketing activities - advertising, merchandising, PR events, pricing, promotions and even through direct experience of the client with its production. The audience perceives the message of the brand, but now as a "package" of impressions, feelings (i.e. emotional attitudes) and general evaluation.⁹

The product or service having a "natural" being to a certain extent, in fact represents

⁸ Approximately like that is the story of cigarettes Marlboro, described by Jacques Seguela. The aim of their first ads was to highlight adventurism and aggression, while subsequently it turns out that smokers perceive the brand as a symbol of space and freedom of nature in contrast to the urban environment and stress of the offices (Seguela, 2004: 73-80).

⁹ „The hidden part of the iceberg is a brand's 'cultural unconscious' (...) made up of associations, similarities and significant differences.” (Evans, 1999: 15).

the signifier in the sign – brand. The signified is the promise that meets the emerging needs and expectations of the market (Fig.3). The development of the idea - brand is rooted in the minds of consumers, but was inspired by purely existential needs and/or personal and social necessities. Once delivered to the consumer, it becomes an added value, which derives its power from imagination and human desires (Seguela, 2004: 57). It is so much stronger, as more members of the so-called "target-audience" perceive its messages and the more they leave a deep trace in their memory. Therefore, the "target-audience" should be seen as a narrower range of users against the entire market, which are considered largely equipped to decode the signal coming from the brand and are at the same time solvent in order to gain the promised benefits (see Appendix №2).

Fig.3

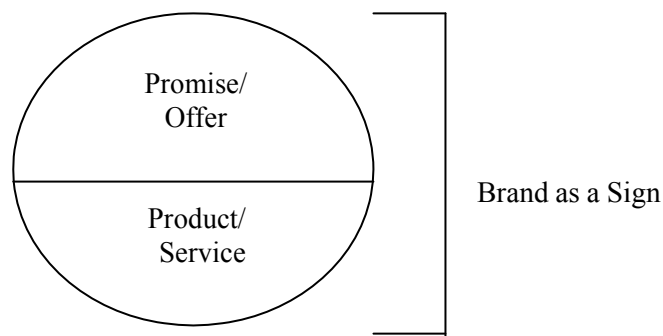

Referring to Roland Barthes, R. Abadzhimarinova indicates that the brand builds a secondary sign system of the product (after it has already a form and content) and is precisely its social myth (2006: 170). She sees the brand as a connotation of a physical commodity, which can lead all the importance and utility of the product, the full force of the desire to own it and all the emotional depths of satisfaction from its use to the removal of this finding as a fact, making this fact and all thoughts and feelings associated with it, just an objective observation."(ibid.: 171).

3. POSITIONING AND BRAND COMMUNICATION

3.1. According to Blagoev, brand positioning¹⁰ means creating an adequate picture of it in the mind of the consumer (2003: 197). This is a major association or a total of 2-3 associations with which we want the buyer to link our brand and to distinguish us from the competition. In the world of super choice, abundance of products with the same functionality and information super-saturation brand management has a dual task - first, to bring the most tightly its offer to the ideal

¹⁰ We use the concept of brand positioning, rather than product positioning because, as mentioned above, the brand has long since become a symbolic substitute of goods and even gives them a force in the course of communication with the target group (see Baleva, 2007 : 390).

concepts and expectations of the target audience and, secondly, to distinguish its proposal from the dozens and sometimes hundreds of alternatives, coming from the competition (Baleva, 2007: 390).

Positioning theory is based on the observation that the contemporary consumer has neither time and capacity to remember and filter out the countless "reasonable" arguments, rushing from the market, nor to test one by one all the available goods and services. Therefore, his mind simplifies and arranges the amount of data so that they serve as a landmark in the chaos of supply. This process is instinctive and its outcome is the outlining of a map of proposals, which most often stay away from the logic of scientific reasoning of marketers. It is rather an image of stimuli reflected through individual perceptions, coming from different brands, which provides clear and safe formulation of alternatives (Baleva, 2007, 389). These are deep-rooted associations about the characteristics of any known brand which remain stable at the influx of new information and emerge whenever its name is referred to (Blagoev, 2003: 192-193).

3.2. Behind the simple formulation "market positioning" lies a complex process, whose main elements deserve particular attention. Communication activity is present when market positioning comes to influence human consciousness with the aim of getting acquainted with any characteristics of the brand (Floor, 2006: 65¹¹). This is a directly targeted message by an advertising spot, by a positive experience at the time of purchase, through distinctive packaging, with demonstrations of the functional qualities of the product, through PR events or, as it happens in practice, by all known tools of the marketing mix.¹²

"Every act of communication implies the existence of a message transmitted from one source (communicator) to a recipient (addressee) through any transfer (transmission) channel (Doganov, Palfi, 1995: 59-60). The message of the trademark is transferred to the public communication system and, as any deliberate act, it is intended to cause a reaction in the behavior of a person or group of people by affecting their knowledge and emotions (ibid., see. Petrova, 2004: 77). To convince and present itself in its best light, the brand not only uses words, but also other symbols such as music, colors, graphics and even people. Taken together, they are codes in the transmission of which a distortion and/or loss of information is inevitable as the means of expression are insufficient and imperfect (Doganov, Palfi, 1995: 60). Any brand, like people, has body language and to a considerable degree we understand it (Bullmore, 2001: 10). Whenever there is a point of intersection with it, the consumer adjusts his perception instantly and subconsciously to its characteristics. Therefore those who are responsible for the communication

¹¹ „The consumer has to recognize the premises that are made in the brand positioning, in the content of the brand communication. And the look and feel of the communications will have to reflect the brand personality.” (Floor, 2006: 65).

¹² The last statement is formulated in detail by Sergio Zyman (2005b: 104).

them is that their sources, volume and intensity are beyond the control of the transmitting and receiving parties.

The "father" of the positioning concept - Rosser Reeves pays particular attention to the environment in which the communication of a trademark and/or product unfolds. In *Reality in Advertising* he states that the consumer is in a state of constant siege. "He is totally confused. He is relentlessly stormed by television, fiercely attacked by the press, carved by the radio, perplexed by posters. It is very difficult to compel him to remember something, he rather tends to forget easily" (Reeves, 1994: 174). The famous advertising specialist adds that the customer ranks everything in his head according to the individual scale of *his values*. According to the author's metaphor, the mind is filled with "boxes" containing all sorts of information, arguments and facts, some of which overflow in case of new information invasion and some of the old knowledge falls out (ibid.: 185). Therefore, any advertising communication was destined to fight the "*reality of a strictly established capacity*" (ibid.: 186; italic mine – D.T.) On this basis Rosser Reeves builds the thesis for the **Unique Selling Proposition**, and calls the process of introducing it to the memory of consumers "implementation" (ibid.: 193, 203). USP in an advertising message does not come from the praise and hyperbolization reaching the audience, but from what the client as the receiver retrieves from the message. The proposition must carry information about a *specific benefit* from the presented product¹⁴, and its exclusivity has to be related to uniqueness in the product itself or be based on arguments which have not yet been presented to the target audience. It is necessary that the uniqueness is such that it can hinder the competition to produce a better offer or be unable ever to do so (ibid.: 193-194). Otherwise, the message turns into one of the many similar and becomes part of the overall data noise. It will not go its way through the transferring channel 100% and even if it reaches the mind of the receiver it will not have the capacity to remain there.

In this context, USP is defined by Reeves as "*a concentrated expression of the advertising argumentation*" (ibid.: 226; italic mine – D.T.) and from now on he lays the foundations of market positioning as the process of focusing on a single distinctive feature or benefit of the product that has value to the consumer because it is the only way the message of the brand to reach his mind (Katrandzhiev, 2007: 170).

3.3. Further, when the information "attack" is integrated and achieves its goal, it is assumed that in the potential consumer a homogeneous "**image**"¹⁵ is created, which indicates *where* the brand is among the competitors in a given category, and *what* the brand is – what its

¹⁴ "Every consumer buys to meet their specific need, therefore, the selection of information focuses on those properties of the advertised product, which will meet the need of the consumer (Petrova, 2004: 25).

¹⁵ "The image of the brand is built over time and it purposefully appropriates the images, actions and events that define the importance of brand for the consumers ..." (Zyman, 2005b: 91).

mission, power and promises to the audience are, ie in what it is different from the others (see Keller, 1998: 87).

By *where* is meant that no product of a brand „hangs in the air“. The natural cognitive process in humans acts in direction the perceived objects and phenomena from reality to be arranged in hierarchical structures (ibid.: 88-89). In this way memory is organized and proper orientation and stability of knowledge is ensured. This also applies to brands and their products and services. Coca-Cola for example is a beverage, but in this category in general appear also *water, alcoholic and soft drinks*. Water, in turn, is carbonated, natural-mineral and natural-table. Alcoholic beverages are divided into concentrated and fermented drinks, plus beer, as each of the mentioned groups also divides into at least one more sublevel. In soft drinks there are milk, hot liquids such as coffee, tea and chocolate, and various fruit juices. Here are also colas and the so-called. "non colas" (Sprite, 7 up), which are further subdivided according to the flavor or sugar content, etc. In an effort to establish and maintain its brand image, the management team should not forget where exactly its production is located. Since the consumer bears in his mind the structure of the offered goods, any attempt to dilute his knowledge of the location of the brand would be fatal, at least because the complexity in information about a brand automatically leads to forgetfulness.

As already noted, in the course of the "meetings" with the brand the consumer gains experience with the functional features of its products, its promotions, its ads, with its logo and the rest of its elements, which leads to *awareness* of the brand. It is so much stronger, the more often both sides establish contact with each other and leads to faster recall of the brand name and the solutions it proposes to meet the specific needs (ibid.: 89-90). Brand knowledge is a necessary, but not the only condition for establishing strong positions in the mind of the target group. Here the associations take their place, forming the brand image and showing *in what* it differs from its competitors.

3.3.1. Among the types of associations we put **attributes** in the first place. These are the characteristic features, properties or qualities that the consumer believes the product or service must have, which are the basis of their character and they determine the purchase. According to how directly they are related to the functioning of the product, attributes are divided into two subtypes (ibid.: 93 and 95-96):

z *Product related* - these characteristics are related to the physical structure and functions of the product or with the statutory conditions for service provision. All products have major components, parts and/or mechanisms, and many additional ones (extras), enabling them to perform actions or to achieve the effect for which they were created.

z *Non-product related* - they influence the purchase and use of the product/service but are not fundamental to their specific functioning. Among them are the price and colour of the product, the appearance of packaging, reputation and origin of the manufacturer, celebrities/experts which recommend its use, the type of stores that sell it etc.

- *price* is a factor of versatile importance, since it is a major association defining the "value" of the brand and it is very often the lever which forms the complete knowledge of the user for a product category, for chain stores or brands of one owner (ibid.: 95). In the most literal sense, from the viewpoint of the purchaser, price is the sacrifice (a certain share of his cash budget) that he is willing to offer in order to meet his needs through a product or service. When the potential user faces the amount written on the label¹⁶, processes occur that are influenced mostly by various marketing stimuli enabling him to instantly determine where it is on the scale *expensive-cheap* and whether it is located in an equilibrium point *price-quality* (Blagoev 2003: 295). He gets from it a huge volume of information on supply and demand in the category (competition and market situation as a whole), cost, trade concessions, length and structure of distribution channels, etc., and not least on the goals of the manufacturing company (ibid. : 288).

- *the notion about the user and the use* is formed directly from experience with products of the brand or through contacts with persons having such experience (recommendations/ opinions; "word-of-mouth"). One of the tasks of advertising is also to paint a picture for the unfamiliar or poorly informed user where, when and how to use the presented product or service. This may be on a particular day or hour, during a specific season of the year, at an event - formal or otherwise, in carrying out any activity (sports, cultural) in or outside the home, etc. According to Keller, demographic and psychographic factors are crucial - gender, race, age, income, occupation, social status and political views (Keller, 1998: 93-94). In this regard, Sergio Zyman makes the important remark that depending on the audience the differences in the image of the use vary in a wide range, but users will build one, no matter if the manufacturing company takes conscious action on building it or not (Zyman, 2005b: 93).

- *feelings and perceptions* are pointed out by many practitioners to be the core in building the consumer value of the trademark. Among the main supporters of this thesis is longstanding CEO of *Saatchi & Saatchi* Kevin Roberts. In *Lovemarks* he states the following: „Let's stop running after every new fashion fad and rather concentrate on creating lasting and emotional relationships with consumers... They look for what they can love. They insist on having

¹⁶ According to Jack Trout and Al Ries the right place where the high price of a product should be put on is in advertisements, not in the store. If the work on positioning is well done, in front of the label there will be no unpleasant surprises for the consumer because he will already be aware that this product is moving in a certain high price category (Trout, Ries, 1981: 70).

greater freedom of choice, have higher expectations and need an emotional note, which can cause them to make choices" (Roberts, 2004: 36). Thus it is of critical importance advertising, and any other communication to emit positive impulses and associate the brand with positive emotions. Anelia Petrova states that when strong arguments in favor of the product are presented to the audience, the emotion should be only a background that contributes to the perception and processing of information. But when the brand should be distinguished from competitors or to stand out among more familiar brands to the audience, positive emotional stimulation should come to the fore (Petrova, 2004: 119).

- *individuality of the brand* is a reflection of the perceptions and feelings of the consumers with respect to the brand, as if it comes to another human being who has their own character. For example, there are "retro" brands, "modern", "exotic", "fresh", "sophisticated", "vibrant and dynamic", etc.(Keller, 1998: 97-98). Again, advertising has a major contribution to shaping the personality of the brand in the minds of the target audience because it describes specific cases and uses of the product, creates animated characters using real or [famous] people to personify the brand, gives emotions through the whole voice of the spots, thorough the music in them either by their original scripts (ibid).

When building his concept of market positioning of retail brands, Ko Floor states that intangible characteristics of the brand are ultimately much more difficult to imitate than the visible ones because they are the result of its mission, vision and culture that are unique as in humans (Floor, 2006: 67 and 226). Citing the research of David Aaker, Floor indicates five identity dimensions, which are important for the positioning of the brand (ibid.: 228-289): *sincerity* – includes characteristics as “down-to-earth”, “conventional”, “genuine”, “careful”, “classic”, etc.; *excitement* – embraces “flashy”, “young”, “provocative”, “trendy”; *competence* – “secure”, “hardworking”, “serious” and so on; *sophistication* – unites “glamorous”, “sexy”, “pretentious”, “feminine”; and *ruggedness* – here are put “masculine”, “athletic”, “strong”, etc.

3.3.2. The second group of associations are the **benefits**. They represent the values and the importance that consumers attach to the functional attributes of goods and services, ie what they think products do for them. Depending on what motivations are they associated with, benefits are divided into *functional*, *symbolic* and *based on experience* (Keller, 1998: 99):

z *Functional benefits* are based on the core advantages derived from the use of the product or service. Most often they are associated with basic motivations of men such as physiological needs and the needs for security and include the desire to eliminate or avoid some new problems.

z *Symbolic benefits* are related to external benefits of using the product. Usually they

correspond to attributes not directly related to the product or service, especially with the above described *picture of the user*. Symbolicity is rooted in meeting social needs, building self-esteem and personal expression.

z *Experience-based benefits* are related to what it feels like to use a product or service. They have a relation both to the *picture of the consumer* and *of the use*. They satisfy the needs of pure sensory pleasures, of diversity and cognitive stimulation (ibid.: 100).

3.3.3. **Attitude** is the most abstract of the three types of associations and is to a great extent the final result of the overall perception of *attributes* and *benefits* of the product. It is a general assessment of the brand and is most often the fundament on which consumer behavior is built, expressed in purchasing.

To create a model of attitude, it is necessary to resort to the help of psychology as only it is able to lead and define the different functions that the assessment may have (ibid.: 101):

- *utilitarian* - there is a relationship with attitude formed on the basis reward- punishment;
- *function of value expression* - corresponds to the ability to derive individual values or a personal concept;
- *self-defense role* - based on the instinct to protect oneself both from external threats and the inner sense of insecurity;
- *cognitive function* - related to satisfying the need for creating order, structure and meaning.

The consumer builds his notions of the brand depending on the functions to be performed. Thus, the use of certain brands allows him to separately or simultaneously satisfy basic needs, to express his personality, to eliminate the feeling of weakness and vulnerability and/or to simplify decision making. Usually the buyer has his own idea/belief on the benefits the brand brings either from experience or from opinions of others about them. But at the same time he assesses exactly to what extent these benefits are good or bad and what is the likelihood to fully meet the emerged demand (ibid.: 101-102).

3.3.4. Keller adds that associations must be **strong**, to create **favorable attitude**, and to be **unique**, even exactly in this order in order to create a brand of high value (ibid.: 102-103).

z *The strength* of associations in the consumer's mind is expressed in quantity and quality of information which will be called from the memory in connection with the brand and which will influence the purchase decision. Here we return to the process of introducing the brand message as the communication factor plays its role in two directions. First, the strength of associations depends on how the message was originally perceived and secondly, where the data gets. Psychologists describe this process as „encoding“ and „storage“ (ibid.: 104). In the process of encoding the volume of information that comes from outside is important as well as how much from

it passes through the filter of the consumer. The increased attention in the moment of communication involves a bigger amount of perceived and sorted information. Quality, in turn, shows the way information is conceived (ibid.: 104-105). It depends on the specific interest of the client, of his individual values, the social environment, the ability to decode the message, etc.

The storage of data is influenced by many factors and can be assessed only by the speed with which the saved can be called to the surface. The presence of *other* product information is often a reason for disruption or reduction of access to already existing associations for the same brand. If it is too abundant and varied, it may distract the consumer from the main message, to confuse or cause him to overlook the significant. *Time* weakens associations as it gradually reduces their ability to be "called" in time. Very often for their evoking external signs are necessary (visual - specific colors, shapes, logo or character) to serve as reminder tools. The greater their number and frequency of occurrence, especially in the context in which the brand is perceived, the greater the likelihood to promptly bring out on surface the stored information (ibid.: 105).

z Associations vary depending on the extent to which they create *favorable attitude*. This means the audience to perceive the attributes and benefits of the brand as appropriate for satisfying the emerging needs and desires.

Goodwill is a function of *desirability* and delivery options. The first factor is a personification of the motives, standing behind the purchase of a product. According to popular Abraham Maslow's hierarchy these may be basic needs, the need for stability and protection, of social interactivity, self-expression and self-realization. The key point here is that the needs on the higher levels can not be satisfied without first meeting those of the previous step. Marketers also observe a gradation in the importance of the characteristics of the brand from the lower to the higher level according to the following scheme: attributes lead to obtaining benefits and benefits lead to the acquisition of value (ibid.: 106). Thus, desirability can be seen as an indicator of how valuable is a brand to the consumer.

The possibility of actual delivery of the benefits which the brand promises in its communication also has its importance in the general system for creating a positive evaluation. The design and functional characteristics of the product must support the favorable associations, to maintain and strengthen them in time. But difficulties for the brand management occur from the fact that in the presence of stable knowledge of the brand if it is decided to innovate the product it is almost impossible to try to create new perceptions of it (ibid.: 107).

z *Uniqueness* of the associations is at the center of the positioning, in its essence it is a "Unique Selling Proposition", which creates a competitive advantage of the brand. The reason to be purchased that particular product may be communicated through direct comparison with the available alternatives on the market, or to be strongly implied (ibid.: 108). As mentioned earlier, USP may be based on attributes directly or indirectly associated with the product or service or functional benefits and experiences, but it is important to be *specific*.

3.4. Image, in turn, which is the sum of the present associations for the brand, is a result of the deployment of **brand identity**. It is the "main statement" of the manufacturer of what his brand represents and thus it becomes a strategic inspiration for all marketing efforts in shaping the image (Aaker, Joachimsthaler, 2000: 40). Construction of identity can be described as an active effort by the organization to build and maintain lasting ideas about itself to consumers and competitors, which embodies two things - a *promise* to the clients and *responsibility* of the employees (ibid.: 72). To this end, a set of tools is used adding richness, basic fabric and clarity of the brand, the visible outcome of which is the *fundamental position*, which is communicates to the audience (ibid.: 41).

Fig.5

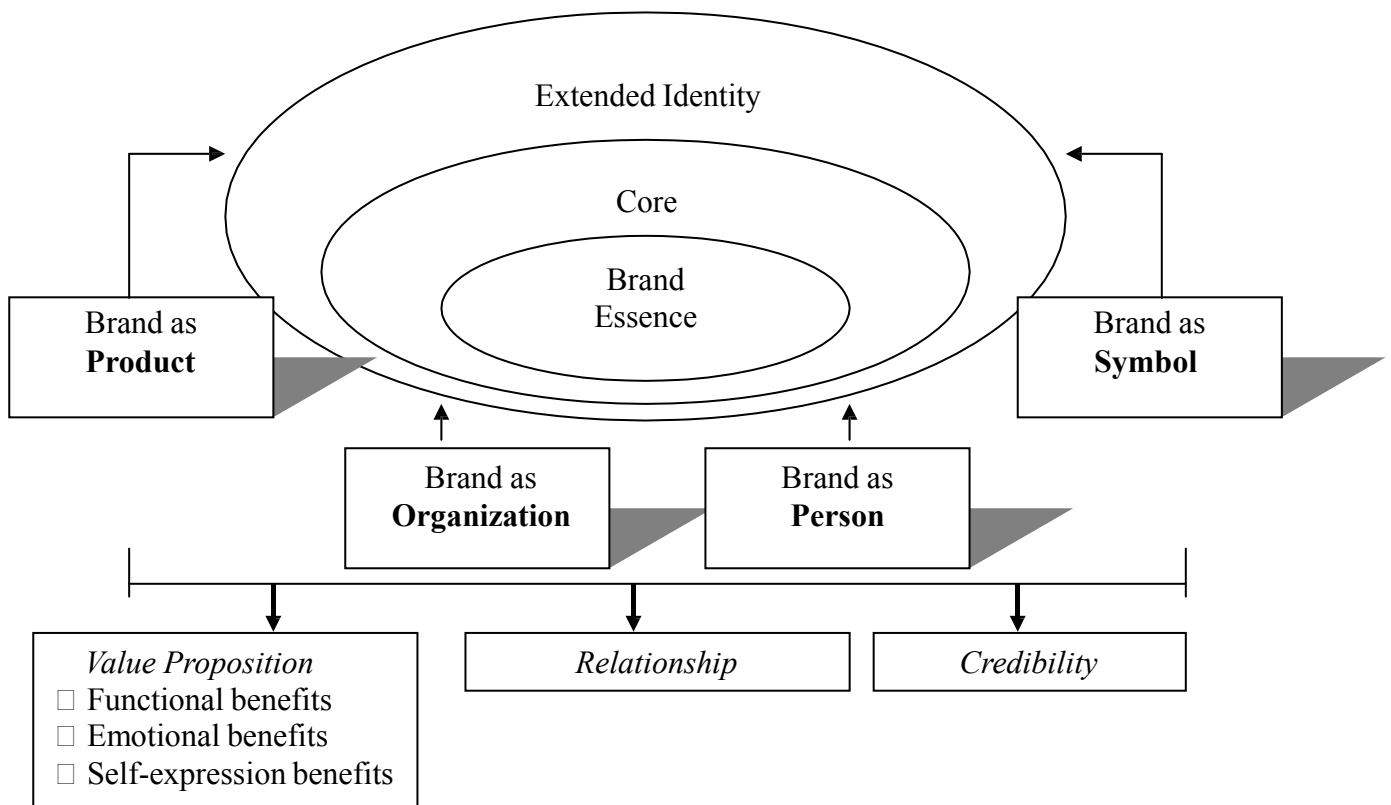

The system of identity as presented by David Aaker (ibid.: 44; Appendix № 1) is an ideal theoretical framework, but in reality not all elements are required for complete construction

of a successful brand. We see that its core is formed from the essence of the brand, whose tasks are to infuse energy into the heart and to stick in one whole the elements of identity. It is a thought or phrase that is not always necessarily exists, but where it does exist, it is a powerful weapon, showing in simple terms on what the brand has focused. Its content must be sufficiently clear and strong to make it stable over time, to vibrate among consumers and to inspire employees and partners of the organization (ibid.: 45). Unlike essence, the final sentence put at the end of an ad is created with a communication purpose and is directed only to the consumer group, to make a concrete proposal for purchase. It changes with each campaign and in accordance with the various tactical objectives of the management and therefore has a limited life (ibid.: 47).

Extended identity is the general term for the various manifestations of the brand - product, organization, personality and character:

z *The product* by its nature carries primarily material characteristics such as attributes, without which no image or identity can exist, but in itself it is not the brand. Through it associations are created, related to the functionality and capabilities, as well as use and quality. But the brand as a mechanism adds the halo of the manufacturer to the product or service, as well as the country of origin, emotional benefits and perception about use.

z *The organization* is particularly important for the realization of services, high-tech products and goods with long life and use (ibid.: 53). The manufacturer, who stands for them becomes crucial because he is much more "visible" to consumers. Therefore, the reputation of the innovator, of the socially responsible and oriented to customer problems is a serious competitive advantage.

z *The personality* of the brand makes a difference with the competitors and delivers value to the target audience. Without it, no brand would be interesting and memorable, it would leave no impression and trace in the minds of consumers, nor could it rely on the awareness and lasting relationships with them. Personality adds vitality and a more real image of the brand and can stimulate its perception as an adviser, friend or just good company (ibid.). If the analysis of identity proves that there are no personality traits, it means that the organization perceives its brand too narrowly.

z *The symbol* is more than a tactical weapon of communication as on a strategic level it opens up opportunities the brand to be recognized quickly and easily. It can be a slogan, melody, logo, gesture, a real person, a customer loyalty program, a certain color or a distinct packaging (ibid.: 54). In this sense it is the external sign which in Keller's definition, acts as a key to the information contained in the memory of the user about the brand. The more saturated with meaning and associations is the symbol, the greater its importance in the structure of identity is.

Therefore, sometimes (as in the case with the logo of Nike, for example) it can be seen not only as an element of the extended identity, but also as an integral part of the brand core (ibid.).

4. PRACTICAL APPLICATION OF THE POSITIONING THEORY

Soon after Rosser Reeves' *Reality in Advertising*, in the 70's of the last century in a series of publications in the magazine "Advertising Age" advertising experts Jack Trout and Al Ries shaped the current positioning theory. The great success of the articles inspired both practitioners to penetrate deeper into the topic, the result of which is the classical elaboration from 1981 *Positioning: The Battle for Your Mind* (Katrandzhiev, 2007: 171).

Prior to developing their thoughts on the topic, Jack Trout and Al Ries pay attention to the fact that positioning stems from the product but in its essence is a process of **"putting" the product into the mind of the consumer**, but not what you do to a product (Trout, Ries, 1981: 3).¹⁷ Their main idea is captured most accurately by Bill Robertson, who summarizes that positioning is "the action by which we create in the mind of our target audience a perception regarding our product that *positively differentiates it* from its competition" (Robertson, 2005: 53; italics mine – D.T.). Thus the positioning concept automatically becomes a communication problem, which requires redefining of the basic task of advertising. According to the cited authors, the time of boasting words in advertising spots is already over, as time has come the products on the market to be compared with each other. So positioning comes to the fore as a powerful communication weapon (Trout, Ries, 1981: 2). It does not exclude the "sacred" principles of the advertising industry - poetic speech and the expressive means of art, but its main purpose is to convey directly and as accurately and clear the promise to the audience.

In part, the promise requires the message to conform to reality, i.e. to the available material present in the mind of the consumer and not to concepts and forms unknown to him. There is no need to rely on the different and super original, since it is much easier and more successful to work with associations already created in the mind, rather than building new ones (ibid.: 5). In this regard, Trout and Ries expressed their sincere amazement how much is being invested in attempts to change minds through advertising, while in our information overload society human mind perceives only signals and signs, which comply with previous experience or knowledge already acquired¹⁸. Like Reeves' "overflowing boxes" , they believe that setting new

¹⁷ In *Differentiate or Die* we encounter the following formulation: "Positioning is how you differentiate your product in the mind of its potential users. (...) If you understand how the mind works, you will understand positioning too." (Trout, Rivkin, 2002: 102).

¹⁸ "Don't play semantic games with the prospect. Advertising is not a debate. It's a seduction." (Trout, Ries, 1981: 76).

information in the memory of the receiver is only possible if the already existing data is removed (ibid.: 7). Advertisers do not see that the messages they create and send are only the visible part of a huge iceberg, as we interact daily in thousands more confusing ways. So the environment saturated with messages (see fig. 4) itself becomes a channel for transfer to filter data and only a small part of the message reaches the consumer's mind (ibid.: 7-8).

In the original text Trout and Ries introduce the term *prospect* (1981: 3), which describes the object of the communication attack by the brand. It is crucial to understand the relationship brand - target audience, because the intentional selection of the word suggests that the consumer should be seen as a "perspective" to our brand, as an "active space" in which the brand projects its signified - the promise and the proposal. In his mind the latter turns into expectations and a general assessment and if we can present it visually, it would be a three-dimensional graph, where points are mapped indicating the location of the brand as relevant to user-significant attributes, characteristics and relationships.

Hence it follows that positioning is not an isolated act but an organized system for the detection of free slot in the mind and attacking it by appropriate means at the appropriate time and under appropriate conditions (Katrandzhiev, 2007: 171). Therefore, Jack Trout and Al Ries insist that in communication "less is more", which means that, contrary to the growing chaos of the communication environment, the sender should simply and clearly formulate his message - „to sharpen” it, to be able to reach the minds and to leave there a long trail (Trout, Ries, 1981: 8-9) - "The best way to penetrate into the human mind, which by nature hates complications and confusion, is by simplifying your message to the extreme. Among the most influential marketing programs are the ones that focus the attention on a single word. (...) Focus entirely on ...a powerful differentiating idea and try to deploy it in the mind of potential users of your product. Through this highly impressive signal, thanks to which you will be able in a clever way to infiltrate and establish "direct contact" with people's minds, you will help the same minds suddenly "see" - as if struck by lightning - how simple they can solve their problems by using your product. "(Trout, Rivkin, 2002: 107-108). The natural progression in the evolution of the market we are witnessing today is the "era of positioning". Creativity is no longer the key to success and, according to Trout and Ries it is time advertising to return to harsh reality. And it suggests that to "rise above the crowd" you need to create a place in the mind of the consumer. The short way to it is creating the perception that you are the first in something or somewhere, although this is not necessarily the entire truth. The authors recall that there is a reasonable cause America to get its name not from its actual discoverer Christopher Columbus, but from the traveler Amerigo Vespucci, who traveled to the New World five years later. While Columbus was more interested in gold and the Spanish

noble title, Vespucci was able first to point out that this, rather than Asia, was a completely unknown territory. The more important step is that the latter spread intensively information throughout Europe about the revolutionary discovery of the then geography, which earned him the trust of the royal yards and the privilege to name a whole continent in his honor, while Columbus ended his life in prison (ibid.: 29 – 30). A lot of the today known goods and services have a similar story, as the names of the brands that introduced them are so deeply embedded in the memory of buyers that is almost impossible to be displaced from there. Their priority was to become aware of the fact that *you have only one chance to make a first impression* and they have benefited fully from the situation. In *Differentiate or Die* Trout justifies this fact again with the mechanisms of the human psyche: "The first remains the first, because people believe that the first is the original, but all that came later were copies or imitations. It is understood that the original has more knowledge and more experience." (Trout, Rivkin, 2002: 116, italic mine – D.T.).

According to psychologists from Harvard University, quoted by Trout and Ries, the average person can handle a maximum of seven units in his memory. This means that when someone is asked to list brands producing certain products, the respondent will indicate at most seven such cases, moreover, if they are representatives of a category that is of immediate interest to him. If the products do not fit in his closest range of needs, he probably will indicate only one or two brands familiar to him from general culture (Trout, Ries, 1981: 35). This suggests that mind as limited capacity for receiving and processing of incoming information and defocuses easily; it arranges the incoming data in a way that allows people to navigate in the surrounding environment, and all sides appear redundant.

Ranking of brands resembles a ladder, each step of which is a separate brand (ibid.37). Some "product ladders" are composed of only few steps, others contain more, but as noted, hardly exceeding seven positions. For a brand to climb at least one step up the scale of the user, it is required to displace the competitor who is there. Usually it is much more difficult than to descend to a lower level or just come off the "ladder". Therefore experienced consultants advise that when advertising is used to introduce new products, instead of starting unequal struggle with stagnant knowledge of already popular brands, it is more appropriate to attempt to create a completely new "ladder" on top which to distinguish the name of the communicated brand. But even in such a situation it seems to be more successful to *explain what is NOT your new product*, rather than wasting efforts and resources to describe what it IS (ibid.).

Further on, Jack Trout and Al Ries pay the necessary attention to the name as a factor that plays a significant role in the battle for the mind as it is a "hook" with which the brand is attached to the "product ladder" (ibid.: 89). Moreover, the name is "the first point of contact

between the communication and mind. Not good or bad in it from an aesthetic point of view determines the efficiency of the message, but its relevance "(ibid.: 99). Here the authors have in mind that the reasonably selected name is what in a few words or best in just one word differentiates the brand instantly and creates associations to the consumer for the benefits it offers. Unlike lawyers, marketers and brand managers love to walk the edge and tolerate the creation of names that could describe an entire category at risk to become a generic term and lose their registration. „A strong, genetic-like, descriptive name will block your me-too competitors from muscling their way into your territory. A good name is the best insurance for long-term success.” (Trout, Ries, 1981: 91). Classic examples of the successes of the name are Scotch and Xerox, which are doomed to be "top of mind" (both the top "step" and the name of the whole "ladder"), but their position has its weaknesses, because under these brands they could not sell anything else.

The famous French advertiser Jacques Seguela builds his idea of establishing brand identity along the lines of human beings¹⁹ - as a combination of **physique, character and style** [*Holy Trinity of the Brand*, Seguela, 2004: 142]. First we turn the product into a person and then the person into a star.

Fig.6

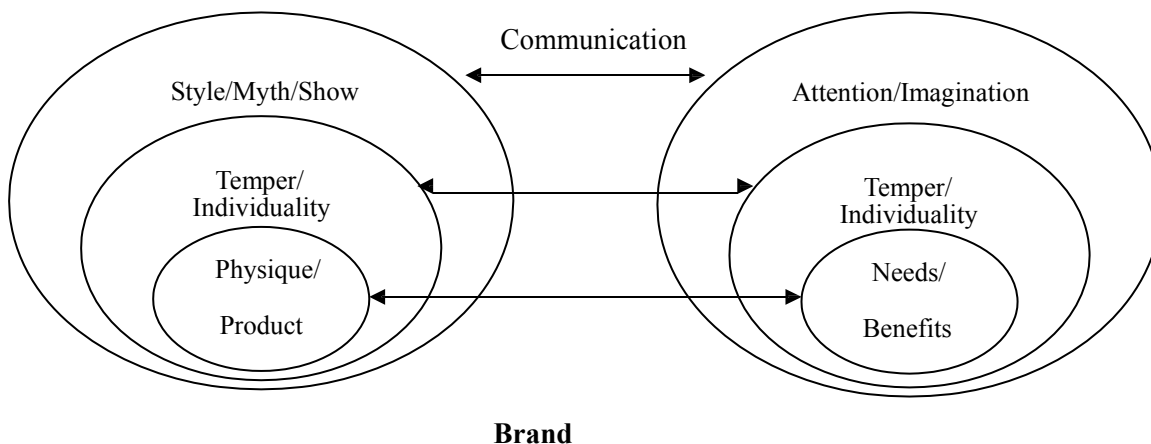

z By *physique* we understand the product itself, without which there would be no commercial success. But if it is relied only on its lifeless offerings in the store, that means its purchase to turn into an automatic act, deprived of real choice and emotion. When developing a "star", patient observation is required to filter out that exclusivity that will bring competitive advantage. For this purpose, Seguela and his colleagues used the so-called. "Chinese portrait", which aims to simultaneously provoke the imagination in terms of the product and to identify its

¹⁹ "The product is also born ... The product grows up and starts to make a living. We measure its height not in centimeters, but in conquered percents of the market. (...) Above all, the product is able to communicate. As we create its brand, we give it the gift of speak." (Seguela, 2004: 48).

target group (ibid.: 242). The questionnaire concerns key issues such as strengths and weaknesses of the product, the meaning of its existence, in what circumstances it will be used, who will buy it and how often, with which car, shop, animal or star of show business it can be compared, etc. For the accuracy from the physique point of view it is important because the alleged qualities of the product must not be imaginary, but completely real and visible, to generate purchases. According to Seguela the good advertiser could make the weaknesses of the product qualities in the eyes of buyers.

z The *character* of the brand is what the Marlboro cowboy represents - a collective and intelligible image of the spaciousness, adventure and freedom. He generates these associations regardless of the context in which he is placed, even without holding a cigarette in his mouth (ibid.: 80). The "star" brand is completely understandable, because the audience "wants to get simple answers to their simple motivations" (ibid.: 121-122). It is based on the desire for identification inherent to all consumers and aims to extremes, recognizing that it is dominated by passion and strives to the perfect. In Seguela's words that represents honesty in front of the buyer, which ensures durability of the relationship and allows the brand to sell countless times. In this regard, the character suggests the presence of symbols, which means that the brand must have a public image and must be filled with interesting stories. "The quality and low price are the least they require [the consumers - D.T.] from a brand. In addition, they want to receive an offer to escape to the world of dreams." (ibid.: 129).

z *Style*, in turn, is the manner in which the brand is communicated. Here the French advertiser pays tribute to symbols. They must be unique and actively maintain the brand associations, such as the character from the comics of Michelin, the specific font of Coca-Cola or like the stylish gentleman with a bandage on the eye - the face of "U. S. Hathaway" shirts. The author adds that the advertising of the "star" must be an endless spectacle, full of surprises for consumers (ibid.: 136). The ascension over the propaganda noise and media saturation requires the communication of the brand in the first place to be *distinct*, and then *varied*, but without losing focus. Therefore, only the style is "allowed" to change over time and according to the nature of the audience because it is the one element in the "Trinity" of the brand, which is fighting for attention.

In two of his books which gained wide popularity - *The End of Marketing as We Know It* and *Renovate Before You Innovate* longtime marketing manager of Coca-Cola Sergio Zyman presents his own reading on the topic of market positioning, summarized in the following passage: "The key to good positioning is take control of the dialogue with your customers and consumers early on and never lose it. If you do not, your competitors will do, and this is something you should never allow because whoever controls the dialogue, controls positioning too." (Zyman, 2005:158).

In fact, for someone from the "kitchen" of management as Zyman, "dialogue" is continuous process of speaking on behalf of the brand, with which it presents its position in front of the consumers, and they respond with a clear idea of its essence and make choices in its favor. If the brand sends vague and confusing messages and/or deviates from the topic, then customers will dissipate and move away from communicating with it. Their attention to its messages will decrease, brand loyalty will suffer²⁰ and hence purchases will suffer, since they will be sporadic (meaning little or none) and they will lack the characteristic emotional intensity.

Control over the dialogue is not restricted to setting clear limits to the audience how far the offer of our brand extends. The market is a community including competition, which means that the statement of a trademark automatically affects the ability of other players in the category for gaining a share. Zyman defines it as a simple marketing principle that we choose or territory for which we will fight on the competitive field, or competitors will do it instead of us (Zyman2005b: 98). Moreover, the author recommends active offensive actions against enemy positions, using every opportunity to limit the ways in which competitors can be defined by a single characteristic or quality, while our brand in turn expands theirs (ibid., 100). Two of the instruments for achieving it are the *comparison* and *copying*. In the first case, without a harsh and negative tone, direct comparison (repositioning of the opponent) allows both to highlight the positive aspects of our brand and to set evaluation standards among consumers, which is literally taking control over the dialogue. Withdrawal of members from the competition is possible by re-positioning of our brand. Thus, based on newly discovered needs and desires that exist in the target audience, ground for more suggestions is created and more arguments for purchase are put. Further, Sergio Zyman acknowledges the key role of identity in brand positioning. He states that the position is what the management team wants the audience to think and feel in relation to the brand, while the image is the overall impression of it (ibid.: 94). This is why he has taken part in developing a formula aimed at helping the managerial decision what position to be reclaimed and what promise to be given. It states: Define, Offer, Announce it and it will bring you Luck (ibid.) where: 1) "Defining" is the basis of the branding process in general leading behind 2) The "Unique Selling Proposition". Further comes the "Announcement", i.e. communication which (if created and directed properly will lead to 4) "Success" because it will reach the mind of the consumer and store the message in his memory for a long time.

²⁰ Led by the generally accepted economic principle, formulated by Wilfredo Pareto that 20% of brand loyal buyers make 80% of the profits of the brand, Zyman warns against practicing horizontal marketing as an end in itself: "Much more effective is ..to build relationships with customers and then work on people who know you to buy more than every day to search for new customers. "(Zyman, 2005b: 79).

GENERAL CONCLUSIONS

Positioning is rightly regarded as a constant ongoing process of communication with the target audience, of continuous development and renewal of the meaning of existence of the trademark. It is an essential, even to say the only task of brand management and it existed no matter if in the course of history managements of the companies practiced it consciously or not. As a sufficiently seriously-perceived management process, the clear positioning strategy is both a highly commercial weapon and face of the manufacturing and administrative life behind the product. The existence and proper use of positioning depends on the detailed picture of the senior management regarding the identity of the company as a business core and the desired image that this identity wants to show to the entire audience - competitors, partners and above all to users. Studying the nature of the positioning concept leads to the following conclusions:

z Brand identity is set by the basic business mission of the company-manufacturer, which is indispensable; *it is the "anchor" around which gravitates any communication activity of the brand to the outside world;*

z The image is the sum of *current associations of the brand*, an image in the mind of the consumer, which is the result of contacts with the brand, the *image belongs to the target audience*, rather than to the management, although it is possible to match perfectly with the identity assigned to it by the manufacturer;

z The difference between the image and positioning is that the second is the *main association* (or a group of semantically similar ones) that each manufacturer wants to have for its own brand in the overall scheme of the image; usually a feature of the brand, which satisfies needs or whether physiological needs, security, realization or social ones - Volvo is „safety driving”, Nike is „spirit of sports”, Mercedes is „high class”, Virgin is „underdog”, Starbucks is „the third place [between home and office – D.T.]” and so on;

Fig.7

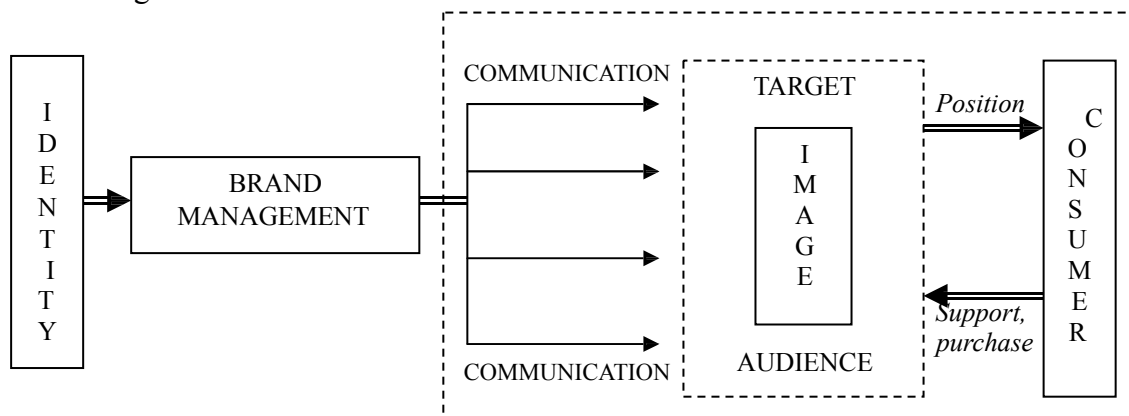

POSITIONING

z The intensity and nature of communication with consumers determine *how* and *how strongly* they perceive the brand; they help in forming the attitude towards it;

z The success of brand positioning efforts is a *function of attracting and retaining the user's attention* to its messages; by captivating the consumer's mind in communication, he becomes an active part - he builds the knowledge of the brand by himself and participates in the maintenance of its mythology (see Seguela);

z *The roots of positioning we can find in the identity and its tip - in communication*; both are important enough and must work together to not arouse a distorted or wrong idea about the place of the brand on the market;

z Positioning with only one word or concept is only possible when it is not isolated, and works aimed at a more integral context; it focuses the efforts of an extensive network of influences from the brand in different channels - merchandising, publicity, promotions, demonstrations, advertising, positive user experience, etc.

APPENDIX №1

VIRGIN BRAND IDENTITY (Aaker, Joachimsthaler, 2000: 46, from fig. 2-3²¹)

Brand essence

Iconoclasm

Core

- **Service quality** (Consistent best-of-category quality delivered with humor and flair)
- **Innovation** (First with truly innovative, value-added features and services)
- **Fun and entertainment** (A fun and entertaining company)
- **Value of money** (Provide value in all its offerings, never just the high-priced option)

Extended identity

- **Underdog** (Fighting the established bureaucratic firm with new creative offerings)
- **Personality** (Flaunts the rules, sense of humor, willing to attack the establishment, competent)
- **VIRGIN symbols** (Richard Branson and his lifestyle; *Virgin* blimp and script logo)

Value proposition

- **Functional benefits** (A value offering with quality, plus innovative extras delivered with flair and humor)
- **Emotional benefits** (Pride in linking to the underdog with the attitude; fun, good times)
- **Self-expressive benefits** (Willingness to go against the establishment; to be a bit outrageous)

Relationship

- **Consumers are fun companions**

²¹ With some changes; bold is in original text.

APPENDIX №2

FUNDAMENTAL CRITERIA FOR MARKET SEGMENTATION (sources: Doganov, Palfie, 1995: pp. 144 – 151 and Pride, Ferrell, 1994: pp. 57 – 61)

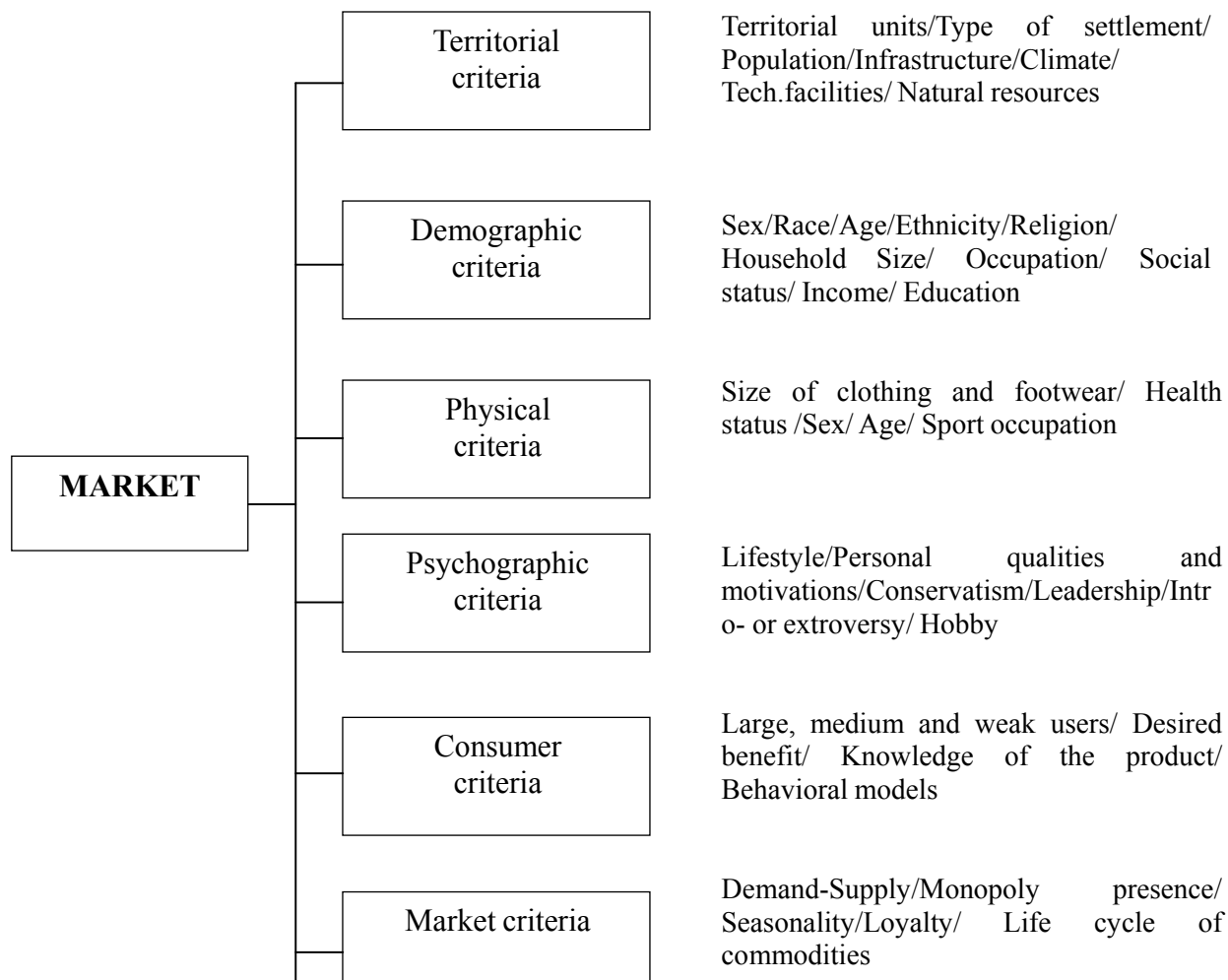

REFERENCES:

In Bulgarian:

- Abadjimarinoва 2006: Абаджимаринова, Румяна (Abadjimarinoва, Rumiјana), Търговска марка – Бренд (Trade mark - Brand), изд. „Сиела”, София (Sofia), 2006;*
- Baleva 2007: Балева, Велина (Baleva, Velina), Продуктът. Маркетингови стратегии и политики (Product Marketing Strategies and Policy), университетско издателство „Стопанство”, София (Sofia), 2007 г.;*
- Blagoev 2003: Благоев, Веселин (Blagoev, Veselin), Маркетинг (Marketing), изд. International University, София (Sofia), 2003 г.;*
- Bresnichka 2004: Брестничка, Румяна (Bresnichka, Rumiјana), Управление на търговските марки (Brands Management), унив. издателство „Стапанство”, София (Sofia), 2004 г.;*
- Doganov, Palfie 1995: Доганов, Д., Палфи, Ф. (Doganov, D., Palfie, Ph.), Рекламата каквато е (The Advertising As It Is), изд. „Princеps”, Варна (Varna), 1995 г.;*
- Katradzhiev 2007: Катранджиев, Христо (Katradzhiev, Hristo), Подходи за позициониране в маркетинговата практика в България – резултати от контент анализа на рекламата в печатните издания у нас (Positioning Approaches in Bulgarian Marketing Practice – Results of Content Analysis of the Advertisements in Printed Issues), „Научни трудове” (“Scientific Works”, an issue of National and World Economy University – Sofia, Bulgaria), изд. УНСС, том I (Vol. 1), 2007: pp. 170-205;*
- Petrova 2004: Петрова, Анелия (Petrova, Anelia), Потребителско поведение и реклама: Психологически аспекти (Consumer’s Behavior and Advertisement: Psychological Aspects), изд. „Делова седмица консулт”, София (Sofia), 2004 г.;*
- Pride, Ferrell 1994: Прайд, У., Фарел, О. (Pride, W., Ferrell, O.C.), Маркетинг: концепции и стратегии (Marketing: Concepts and Strategies), издл. „ФорКом”, София (Sofia), 1994 г.;*
- Baudrillard 1996: Бодрияр, Жан (Baudrillard, Jean), Към критика на политическата икономия на знака (For a Critique of the Political Economy of the Sign), ИК „Критика и Хуманизъм”, София (Sofia), 1996 г.*
- Zuman 2005a: Зийман, Серджо (Zuman, Sergio), Бизнес обновяване. Как да вземем правилните решения (Renovate Before You Innovate. Why Doing the New Thing Might Not Be the Right Thing), изд. „Локус”, София (Sofia), 2005а г.;*
- Zuman 2005b: Зийман, Серджо (Zuman, Sergio), Краят на маркетинга, какъвто го познаваме (The End of Marketing as We Know It), изд. „Локус”, София (Sofia), 2005б г.;*
- Kotler 2002: Котлър, Филип (Kotler, Philip), Управление на маркетинга. Структура на управлението на пазарното предлагане (A Framework for Marketing Management), изд. „Класика и стил”, София (Sofia), 2002 г.;*
- Reeves 1994: Рийвс, Росър (Reeves, Rosser), Реализмът в рекламата (Reality in Advertising), изд. „Princеps”, Варна (Varna), 1994 г.;*
- Rifkin 2001: Рифкин, Джереми (Rifkin, Jeremy), Епохата на достъпа: Новата култура на хиперкапитализма, в която целият живот е платено преживяване (The Age of Access. The New Culture of Hypercapitalism Where All of Life Is a Paid-for Experience), изд. „Атика”, София (Sofia), 2001;*
- Roberts 2004: Робъртс, Кевин (Roberts, Kevin), Марките на любовта (Lovemarks), изд. „Фокус”, София (Sofia), 2004 г.;*

Seguela 2004: Сегела, Жак (Seguela, Jacques), Холивуд пере най-добре (Hollywood Lave Plus Blanc), изд. „Panorama.bg”, София (Sofia), 2004 г.;

Trout, Rivkin 2002: Траут, Джак, Ривкин, Стив (Trout, Jack, Rivkin, Steve), Бъди различен или умри: Оцеляване в ерата на убийствена конкуренция (Differentiate or Die: Survival in Our Era of Killer Competition), изд. „Кръгозор”, София (Sofia), 2002 г.

Fisk 2008: Фиск, Питър (Fisk, Peter), Гениален маркетинг (Marketing Genius), изд. „СофтПрес” ООД, София (Sofia), 2008 г.;

In English:

Aaker 2000: Aaker, David A., Joachimsthaler, Erich, Brand Leadership, The Free Press A Division of Simon & Schuster, Inc., New York, 2000;

Floor 2006: Floor, Ко, Branding a Store. How to Build Successful Retail Brands in a Changing Marketplace, Kogan Page Limited, London-Philadelphia, 2006;

Keller 1998: Keller, Kevin Lane, Strategic Brand Management. Building, Measuring, and Managing Brand Equity, Prentice Hall, Inc, New Jersey, 1998;

Nöth 1987: Nöth, Winfried, Advertising: The Frame Message in Umiker-Sebeok, Jean, Marketing and Semiotics: New Directions in the Study of Signs for Sale, Mouton de Gruyter, Berlin, 1987 (pp. 279 - 292);

Trout, Ries 1981: Trout, Jack, Ries, Al, Positioning: The Battle for Your Mind, McGraw-Hill, New York, 1981;

INTERNET SOURCES:

www1.bpo.bg [the official web-site of Patent Department of R Bulgaria];

<http://www.britishbrandsgroup.org.uk/library> [article by Dick Johnson („Procter&Gamble”), Building Brand Personality, 1996], Accessed 13 Jan 2009;

<http://www.britishbrandsgroup.org.uk/library> [lecture by Jeremy Bullmore („WPP Group”), Posh Spice & Persil, 2001], Accessed 13 Jan 2009;

http://intermind.biz/positioning_rules.pdf [article by Bill Robertson, a president of the consulting group „InterMind”, Ten Rules of Product Positioning, in MM&M, 2005 (pp. 52-58)], Accessed 09 Feb. 2009;

www.spacedoctors.com [Evans, Malcolm, Semiotics, Culture and Communications – The Common Sense of the 21st Century, paper for Australian Market Research Society Conference, 1999], 23 June 2009;

www.troutandpartners.com [the official web-site of „Trout & Partners” Ltd, the consulting company_of Jack Trout].